



# Taylor Products Model IBC-3000

## **Operation and Maintenance Manual**



**Taylor Products**  
**a division of Magnum Systems**  
**2205 Jothi Avenue**  
**Parsons, Kansas 67357-8460**  
**Toll Free: 888-882-9567**  
**Phone: 620-421-5550**  
**Fax: 620-421-5531**

**Web: [www.taylorproducts.com](http://www.taylorproducts.com)**  
**[customerservice@magnumsystems.com](mailto:customerservice@magnumsystems.com)**

**Machine Serial Number: \_\_\_\_\_**

**Sales Order Number: \_\_\_\_\_**

# Important Information

## Conventions

### Safety Alert Symbols

The  symbol indicates that important personal safety information follows. Carefully read this text for the warnings information it contains. The signal word next to each safety alert symbol is defined as:

**WARNING**

*Indicates a potentially hazardous situation that, if not avoided, could result in death or serious injury.*

---

---

**CAUTION**

Indicates a potentially hazardous situation that, if not avoided, may result in minor or moderate injury, or damage to the equipment. This single word may also be used to identify unsafe practices.

---

---



**LOCKOUT**

This symbol will be used anytime that a procedure requires an electrical lockout.

---

---

### Static Sensitive Symbols for Equipment Handling Instructions

The  and  symbols indicate important handling guidelines for proper handling of electronic equipment modules and sensitive components for the prevention of potential damage that could be caused by ESD (electrostatic discharge) during routine maintenance, handling and transportation.

**ESD NOTICE**

To protect against ESD damage to electronic equipment, follow the Standard ESD Prevention Procedures. Failure to use protective measures could result in permanent equipment damage, either immediate or latent, when handling modules.

---

---

**ESD NOTICE**

To protect against ESD damage to electronic equipment containing components, follow the Standard ESD Prevention Procedures. Failure to use recommended protective measures could result in permanent equipment damage, either immediate or latent, when handling components.

---

---

## Standard Electro-static Discharge (ESD) Prevention Procedures

The Model IBC-3000 utilizes many electronic components that are susceptible to damage from Electro Static Discharge. Anytime electronic components are serviced, the following precautions should be followed:

1. Wear a commercial grounding wrist strap.
2. Remove power from the machine.
3. Leave all static sensitive components in their protective packaging until it is time to install the component
4. Always hold static sensitive components by their metal mounting tabs, and/or by their edges

## Important/Notable Information

While all of the information in this manual is important, there are some pieces of information where special attention needs to be paid to avoid equipment damage, or specific information needs to be emphasized. This information will be handled as follows:

***Important:** Indicates an operating procedure, practice, or condition that, if not strictly followed, may cause equipment damage.*

***Note:** Indicates additional information or emphasizes a topic related to the subject being discussed.*

## Personal Safety Instructions

Only qualified personnel should work on or around this equipment. To ensure the highest degree of personal safety, all who use this equipment are required to become thoroughly familiar with all safety instructions contained in this document. Successful and safe operation of this equipment depends upon proper handling, operation, maintenance, and application of associated equipment. Refer to Appendix A of this manual for all safety instructions. Safety instructions are also provided where they apply within the body of this manual.



### **WARNING**

*No information in this manual supersedes or replaces your employer's operating rules. If there is a difference in instructions between this manual and the employer's operating rules, follow the most restrictive instruction.*

*Deliberate misuse or abuse of electronic components may cause personal injury or death.*

---

---

## **Warranty Information**

Seller warrants that the Products will operate substantially in conformance with Seller's published specifications, when subjected to normal, proper and intended usage by properly trained personnel, for a period of one (1) year from the date of shipment to Buyer (the "Warranty Period"). Seller agrees during the Warranty Period, provided it is promptly notified in writing upon the discovery of any defect and further provided that all costs of returning the defective Products to Seller are pre-paid by Buyer, to repair or replace, at Seller's option, defective Products so as to cause the same to operate in substantial conformance with said specifications. Replacement parts may be new or refurbished, at the election of Seller. All replaced parts shall become the property of Seller. Replacement Parts will be billed at list price, unless they are approved as warranty replacement item(s) by the service technician and the technical services manager.

**Lamps, fuses, bulbs and other expendable items are expressly excluded from the warranty. Seller's sole liability with respect to equipment, materials, parts or software furnished to Seller by third party suppliers shall be limited to the assignment by Seller to Buyer of any such third party supplier's warranty, to the extent the same is assignable. In no event shall Seller have any obligation to make repairs, replacements or corrections required, in whole or in part, as the result of (i) normal wear and tear, (ii) accident, disaster or event of force majeure, (iii) misuse, fault or negligence of or by Buyer, (iv) use of the Products in a manner for which they were not designed, (v) causes external to the Products such as, but not limited to, power failure or electrical power surges, (vi) improper storage of the Products or (vii) use of the Products in combination with equipment or software not supplied by Seller. If Seller determines that Products for which Buyer has requested warranty services are not covered by the warranty hereunder, Buyer shall pay or reimburse Seller for all costs of investigating and responding to such request at Seller's then prevailing time and materials rates. If Seller provides repair services or replacement parts that are not covered by the warranty, the Buyer shall pay Seller therefore at Seller's then prevailing time and materials rates. ANY INSTALLATION, MAINTENANCE, REPAIR, SERVICE, RELOCATION OR ALTERATION TO OR OF, OR OTHER TAMPERING WITH, THE PRODUCTS PERFORMED BY ANY PERSON OR ENTITY OTHER THAN SELLER WITHOUT SELLER'S PRIOR WRITTEN APPROVAL, OR ANY USE OF REPLACEMENT PARTS NOT SUPPLIED BY SELLER, SHALL IMMEDIATELY VOID AND CANCEL ALL WARRANTIES WITH RESPECT TO THE AFFECTED PRODUCTS.**

## **Field Service**

Taylor Products can provide field service for start-up assistance, training, maintenance, and replacement/spare parts for new and existing equipment. Contact Taylor Products, at (888) 882-9567, for more information.

This Page Intentionally Left Blank

# IBC-3000

## Table of Contents

Chapter	Page
<b>1 Product Description .....</b>	<b>1-1</b>
1.1 General Description .....	1-1
1.2 Introduction .....	1-1
1.3 Manual Scope .....	1-1
1.4 Electrical Requirements .....	1-1
1.5 Pneumatic Requirements .....	1-1
1.6 Major Systems and Components .....	1-2
1.6.1 Main Frame .....	1-3
1.6.2 Inlet Flange .....	1-3
1.6.3 Inflatable Bag Spout with Nylon Belt Collar .....	1-4
1.6.4 Adjustable Locking Bag Strap Hangers .....	1-5
1.6.4.1 Optional Remote Bag Strap and Neck Seal Release .....	1-6
1.6.5 Machine Controls .....	1-7
1.6.5.1 Non-Weighing Controls .....	1-7
1.6.5.2 Standard T4000 Weighing Controls .....	1-8
1.6.5.3 Optional T3000 Weighing Controls .....	1-11
1.6.6 Pneumatic System Components .....	1-15
1.6.6.1 Pneumatic Pressure Regulators .....	1-15
1.6.6.2 MAC Valves .....	1-15
1.6.6.3 Platform Lift Cylinders .....	1-16
1.6.7 Electronic Load Cell Weighing System .....	1-17
1.6.7.1 Load Cell Connections with T4000 Control Panel .....	1-18
1.6.7.2 Load Cell Connections with T3000 Control Panel .....	1-19
1.6.8 Step Sequence .....	1-19
1.6.9 Bag Liner Inflators .....	1-20
1.6.10 Lift Platform .....	1-21
1.6.10.1 Lift Platform Cables .....	1-22
1.6.11 Lift/Weigh Platform .....	1-23
1.6.12 Settlers .....	1-23
1.6.13 Drum Filling Attachments .....	1-24
1.6.14 Pallet Dispenser .....	1-24
1.6.15 Conveyors .....	1-25
1.6.16 Purge Kit .....	1-26
<b>2 Receiving Equipment .....</b>	<b>2-1</b>
2.1 General Description .....	2-1
2.2 Uncrating the Equipment .....	2-1
<b>3 Setup/Installation .....</b>	<b>3-1</b>
3.1 General Description .....	3-1
3.2 Making Electrical Connections .....	3-1
3.3 Making Pneumatic Connections .....	3-1
3.3.1 Lubrication Requirements .....	3-1
3.4 Mechanical Setup .....	3-2

3.5	Making Network Connections .....	3-2
3.6	Establishing Security Settings.....	3-3
3.6.1	Establishing T4000 Security Settings.....	3-3
3.6.2	Establishing T3000 Security Settings.....	3-6
3.7	Calibration.....	3-8
3.7.1	Calibrating the T4000 Control Panel.....	3-8
3.7.1.1	Pre-Calibration, Mechanical Check Procedures.....	3-8
3.7.1.2	T4000 Calibration.....	3-10
3.7.2	Calibrating The Optional T3000 Control Panel.....	3-14
<b>4</b>	<b>Operation .....</b>	<b>4-1</b>
4.1	General Description .....	4-1
4.1.1	Non-Weighing IBC-3000 .....	4-1
4.1.2	Weighing IBC-3000 .....	4-1
4.2	General Fill Cycle Information .....	4-1
4.2.1	Typical Fill Cycle .....	4-2
4.3	Operational Controls .....	4-3
4.3.1	Control Box With T4000 Control Panel.....	4-3
4.3.2	Control Box With T3000 Control Panel.....	4-5
4.3.3	PanelView (PV300) Controls .....	4-7
4.3.3.1	PV300 Menus .....	4-7
4.4	Initial Setup .....	4-11
4.4.1	Setting Up A Non-Weighing IBC-3000.....	4-11
4.4.2	Setting Up A Weighing IBC-3000 With A T4000 Control Panel.....	4-11
4.4.3	Setting Up A Weighing IBC-3000 With A T3000 Control Panel (Optional).....	4-12
4.5	Operational Modes.....	4-13
4.5.1	AUTO Mode.....	4-14
4.5.1.1	Settler OFF, or No Settler.....	4-14
4.5.1.2	Settler On.....	4-14
4.5.2	MANUAL Mode .....	4-15
4.5.2.1	Settler OFF or No Settler.....	4-15
4.5.2.2	Settler On.....	4-16
4.5.3	HAND Mode .....	4-16
4.6	Starting the Unit.....	4-17
<b>5</b>	<b>Preventive Maintenance .....</b>	<b>5-1</b>
5.1	General Description .....	5-1
5.2	Daily Maintenance Procedures .....	5-1
5.2.1	Cleaning.....	5-1
5.2.2	Check All Fasteners.....	5-1
5.2.3	Drain Water From the Water Separator.....	5-2
5.3	Monthly Maintenance .....	5-2
5.4	Purge Kit Maintenance.....	5-2
<b>6</b>	<b>Troubleshooting.....</b>	<b>6-1</b>
6.1	General Description .....	6-1
6.2	The Troubleshooting Process.....	6-1
6.3	Trouble Symptoms.....	6-1
6.3.1	Machine Will Not Power On.....	6-1
6.3.2	Machine Will Not Start When the Start Button is Pressed.....	6-2
6.3.3	Inflatable Neck Seal Will Not Inflate .....	6-2
6.3.4	Platform Will Not Raise .....	6-3

6.3.5	Container Weights are Erratic .....	6-3
6.3.6	Scale is Not Accurate .....	6-4
6.3.7	Scale Does Not Return to Zero.....	6-4
6.3.8	The Weighments are Always Too Light.....	6-4
6.3.9	Load Cell Fails Frequently .....	6-4
6.3.10	The Weighments are Always Too Heavy.....	6-5
6.3.11	The Weighments Fluctuate Between Too Light and Too Heavy .....	6-5
6.4	System Alarms .....	6-6
6.4.1	T4000 Alarms .....	6-6
6.4.2	T3000 Alarms .....	6-7
6.5	PLC Error Messages .....	6-7
6.5.1	Status Messages.....	6-7
6.5.2	Reminder Messages.....	6-7
6.5.3	Warning Messages.....	6-7
6.5.4	Fault Messages .....	6-7
<b>7</b>	<b>Repair and Adjustment .....</b>	<b>7-1</b>
7.1	General Description .....	7-1
7.2	System Adjustments.....	7-1
7.2.1	Air Pressure Adjustments .....	7-1
7.2.1.1	Filter/Regulator/Lubricator (FRL) Assembly .....	7-1
7.2.1.2	Inflatable Neck Seal Air Pressure Regulator .....	7-2
7.2.2	Timer Adjustments .....	7-2
7.3	System Component Replacement .....	7-3
7.3.1	Spout Replacement .....	7-3
7.3.1.1	Spout Removal .....	7-3
7.3.1.2	Spout Installation.....	7-3
7.3.2	Inflatable Bladder Replacement (Open Mouth Bag Spout).....	7-4
7.3.2.1	Inflatable Bladder Removal.....	7-4
7.3.2.2	Inflatable Bladder Installation .....	7-5
7.3.2	Air Supply Line Replacement .....	7-8
7.3.2.1	Air Supply Line Removal.....	7-8
7.3.2.2	Air Supply Line Installation .....	7-8
7.3.3	Air Fitting Replacement .....	7-8
7.3.3.1	Air Fitting Removal.....	7-8
7.3.3.2	Air Fitting Installation .....	7-8
7.3.4	Air Filter/Regulator/Lubricator (FRL) Replacement.....	7-9
7.3.4.1	FRL Assembly Removal .....	7-9
7.3.4.2	FRL Assembly Installation.....	7-10
7.3.5	MAC Valve Replacement.....	7-10
7.3.5.1	MAC Valve Removal .....	7-10
7.3.5.2	MAC Valve Installation.....	7-11
7.3.6	Lift Platform Pneumatic Cylinder Replacement.....	7-11
7.3.6.1	Lift Platform Pneumatic Cylinder Removal .....	7-11
7.3.6.2	Lift Platform Pneumatic Cylinder Installation.....	7-12
7.3.7	Platform Carriage Cable Replacement .....	7-13
7.3.7.1	Platform Carriage Cable Removal.....	7-13
7.3.7.2	Platform Carriage Cable Installation .....	7-13
7.3.8	Platform Carriage Pulley Replacement .....	7-14
7.3.8.1	Platform Carriage Pulley Removal .....	7-14
7.3.8.2	Platform Carriage Pulley Installation .....	7-14

7.3.9	Lift Platform Proximity Switch Replacement .....	7-15
7.3.9.1	Lift Platform Proximity Switch Removal .....	7-15
7.3.9.2	Lift Platform Proximity Switch Installation.....	7-15
7.3.10	Load Cell Replacement .....	7-16
7.3.10.1	Load Cell Removal .....	7-16
7.3.10.2	Load Cell Installation.....	7-17
7.3.11	Vibratory Settler Replacement .....	7-17
7.3.11.1	Electronic Vibratory Settler Removal.....	7-17
7.3.11.2	Electronic Vibratory Settler Installation .....	7-18
7.3.11.3	Pneumatic Vibratory Settler Removal .....	7-18
7.3.11.4	Pneumatic Vibratory Settler Installation.....	7-18
7.3.12	Knife Gate Assembly Replacement.....	7-18
7.3.12.1	Knife Gate Assembly Removal.....	7-18
7.3.12.2	Knife Gate Assembly Installation .....	7-19
7.3.13	Knife Gate Replacement.....	7-19
7.3.13.1	Knife Gate Removal .....	7-19
7.3.13.2	Knife Gate Installation .....	7-20
7.3.14	Knife Gate Cylinder Replacement.....	7-20
7.3.14.1	Knife Gate Cylinder Removal .....	7-20
7.3.14.2	Knife Gate Cylinder Installation .....	7-20
7.3.15	Bag Strap Hanger Release Rod Replacement.....	7-21
7.3.15.1	Bag Strap Hanger Release Rod Removal .....	7-21
7.3.15.2	Bag Strap Hanger Release Rod Installation .....	7-21
7.3.16	Bag Strap Hanger Automatic Release Cylinder Replacement.....	7-21
7.3.16.1	Bag Strap Hanger Automatic Release Cylinder Removal .....	7-21
7.3.16.2	Bag Strap Hanger Automatic Release Cylinder Installation .....	7-22

<b>Glossary .....</b>	<b>Glossary-1</b>
-----------------------	-------------------

<b>Index .....</b>	<b>Index-1</b>
--------------------	----------------

<b>Appendix A Safety Procedures .....</b>	<b>Appendix A-1</b>
---	---------------------

<b>Appendix B Spare Parts .....</b>	<b>Appendix B-1</b>
-------------------------------------	---------------------

<b>Appendix C Mechanical Drawings .....</b>	<b>Appendix C-1</b>
---	---------------------

<b>Appendix D Electrical and Pneumatic Drawings.....</b>	<b>Appendix D-1</b>
--	---------------------

<b>Appendix E T3000 Control Panel User Guide .....</b>	<b>Appendix E-1</b>
--	---------------------

<b>Appendix F Custom Features.....</b>	<b>Appendix F-1</b>
--	---------------------

## List of Figures

<b>Figure</b>	<b>Page</b>
Figure 1-1. Main Frame .....	1-3
Figure 1-2. Inlet Flange with Knife Gate.....	1-3
Figure 1-3. Inflatable Bag Spout with Nylon Belt Collar.....	1-4
Figure 1-4. Adjustable Locking Bag Strap Hangers (one side shown).....	1-5
Figure 1-5. Operation of the Adjustable Locking Bag Strap Hangers.....	1-5
Figure 1-6. STRAP RELEASE Button.....	1-6
Figure 1-7. Remote Bag Strap and Neck Seal Release.....	1-6
Figure 1-8. T4000 Control Panel .....	1-8
Figure 1-9. Sample Standard Weighing Control Box With T4000 Control Panel (Shown with Optional Features).....	1-9
Figure 1-10. Inside the Standard Weighing Control Box (Shown with Optional Features).....	1-10
Figure 1-11. T3000 Control Panel .....	1-11
Figure 1-12. Sample T3000 Control Box .....	1-13
Figure 1-13. Control Panel with T3000 Control Panel – Internal Components .....	1-14
Figure 1-14. Pneumatic Pressure Regulators .....	1-15
Figure 1-15. MAC Valve Mounting Location .....	1-15
Figure 1-16. Platform Lift Cylinder (1 of 2 shown) .....	1-16
Figure 1-17. Load Cell Arrangement.....	1-17
Figure 1-18. Hardy Summing Board .....	1-18
Figure 1-19. T3000 Junction Box Connections .....	1-19
Figure 1-20. Self-Contained Bag Liner Inflator .....	1-20
Figure 1-21. Standard Lift Platform.....	1-21
Figure 1-22. Optional Takeaway Conveyor Platform.....	1-21
Figure 1-23. Lift Platform Cables.....	1-22
Figure 1-24. Lift Platform Connection to the Weigh Carriage Frame.....	1-23
Figure 1-25. Electronic Vibratory Settler (1 of 2 used).....	1-23
Figure 1-26. Drum Filling Attachment .....	1-24
Figure 1-27. Pallet Dispenser.....	1-24
Figure 1-28. Optional Takeaway Conveyor (3-Chain Version Shown) .....	1-25
Figure 1-29. Purge Kit .....	1-26
Figure 2-1. Shipping Bracket.....	2-2
Figure 2-2. Threaded Rod Used to Lock the Weigh Carriage During Shipping .....	2-2
Figure 3-1. Lubricator – Oil Flow Control .....	3-2
Figure 3-2. Placing The Cursor In Front Of Security .....	3-3
Figure 3-3. Placing The Cursor In Front Of Set Password.....	3-3
Figure 3-4. Set Password Menu.....	3-4
Figure 3-5. Password Set To 123.....	3-4
Figure 3-6. Verify Password.....	3-4
Figure 3-7. SECUR Menu Item Shown Above Function Key.....	3-5
Figure 3-8. Parameter Shown Locked .....	3-5
Figure 3-9. Load Passing Through Load Cell.....	3-9
Figure 3-10. Placing the Cursor In Front Of Calibration.....	3-10
Figure 3-11. Placing The Cursor In Front Of Trad Cal .....	3-10
Figure 3-12. Placing The Cursor In Front Of Zero Value .....	3-11

Figure 3-13. Span Value Displayed.....	3-11
Figure 3-14. Hanging A Calibration Weight From The Bag Straphangers.....	3-12
Figure 3-15. Placing A Calibration Weight On The Weigh Platform.....	3-13
Figure 3-16. Calibration Line.....	3-14
Figure 3-17. Selecting TRAD Calibration.....	3-14
Figure 3-18. Checking Zero Value.....	3-15
Figure 3-19. Setting Span Value.....	3-15
Figure 4-1. Bulk Rate vs. Dribble Rate.....	4-1
Figure 4-2. T4000 Control Panel.....	4-3
Figure 4-3. Control Box with T4000 Control Panel.....	4-4
Figure 4-4. T3000 Control Panel.....	4-5
Figure 4-5. Control Box with T3000 Control Panel.....	4-6
Figure 4-6. IBC-3000 ON/OFF Switch.....	4-11
Figure 4-7. Mode Switch (Shown In AUTO Mode).....	4-13
Figure 5-1. Air Supply Line Water Separator.....	5-2
Figure 7-1. Air Filter/Regulator/Lubricator Assembly.....	7-1
Figure 7-2. Inflatable Neck Seal Air Pressure Regulator.....	7-2
Figure 7-3. Spout.....	7-3
Figure 7-4. Loosening the Setscrew on the Top Compression Ring (Spout Removed From Machine).....	7-4
Figure 7-5. Positioning the New Bladder on the Spout.....	7-5
Figure 7-6. Using the Tensioning Tool.....	7-5
Figure 7-7. Tucking the Excess Compression Ring Under.....	7-6
Figure 7-8. End of Spout Exposed.....	7-6
Figure 7-9. Positioning Flap So Upper Compression Ring Can Be Installed.....	7-6
Figure 7-10. Proper Positioning of the Top Compression Ring.....	7-7
Figure 7-11. Flap Covering the Top Compression Ring.....	7-7
Figure 7-12. Air Supply Fitting.....	7-9
Figure 7-13. FRL Assembly.....	7-9
Figure 7-14. MAC Valves.....	7-10
Figure 7-15. MAC Valve (Solenoid Removed).....	7-11
Figure 7-16. Lift Cylinder Mounting Nuts.....	7-11
Figure 7-17. Access Hole for Lift Cylinder Lower Clevis Pin.....	7-12
Figure 7-18. Platform Carriage Cable Routing.....	7-13
Figure 7-19. Platform Carriage Pulley.....	7-14
Figure 7-20. Lift Platform Proximity Switch.....	7-15
Figure 7-21. Load Cell Arrangement.....	7-16
Figure 7-22. Electronic Vibratory Settler.....	7-17
Figure 7-23. Knife Gate Mounting.....	7-19
Figure 7-24. Knife Gate Cylinder.....	7-20
Figure 7-25. Bag Strap Hanger Automatic Release Cylinder Mounting.....	7-21

# List of Tables

<b>Table</b>	<b>Page</b>
Table 4-1. PV300 Main Menu .....	4-8
Table 4-2. PV300 Timer 1 Menu.....	4-9
Table 4-3. PV300 Dispenser Menu.....	4-9
Table 4-4. PV300 Dispenser 2 Menu.....	4-9
Table 4-5. PV300 Conveyors Menu .....	4-10
Table 4-6. PV300 Timer 2 Menu.....	4-10
Table B-1. IBC-3000 Spare Parts List .....	B-1
Table C-1. IBC-3000 Mechanical Drawings .....	C-1
Table D-1. IBC-3000 Electrical and Pneumatic Drawings.....	D-1

This Page Intentionally Left Blank

# Chapter 1

## Product Description

### 1.1 General Description

This chapter will provide a high-level product description of the IBC-3000.

### 1.2 Introduction

The Taylor Products Model IBC-3000 is a bulk bag, box, and drum filler. The product feed system is fully adjustable, and the moveable weigh platform minimizes product fall and impact. The IBC-3000 has been designed with a timed discharge to eliminate spillage, as well as controls for single operator convenience.

The IBC-3000 comes in a standard configuration, but can also be ordered with any of the over 40 available options. Depending on how the IBC-3000 is equipped, the IBC-3000 can handle weighments from 100 to 3,000 lbs (45 to 1361 kg.).

The base configuration of the IBC-3000 is a non-weighing machine. The control box will have some manual electrical control buttons and knobs. The base configuration for a weighing IBC-3000 comes with a control box with a T4000 control panel, but is available with an optional T3000 control panel.

### 1.3 Manual Scope

This manual will provide information on installation, operation, preventive maintenance, troubleshooting, and repair/adjustment of the IBC-3000.

The appendices will include safety information, a spare parts list, mechanical/electrical/pneumatic drawings, and information on any custom features.

### 1.4 Electrical Requirements

The IBC-3000 requires two distinct voltages for proper operation. Control circuits operate on 115 VAC, while drive circuits and starter circuits can operate on either 240 or 460 VAC at 50 or 60 Hz.

*Note: The buyer must provide circuit protection and a local circuit disconnect.*

### 1.5 Pneumatic Requirements

The IBC-3000 uses approximately 3-10 CFM (85-283 liters per minute) @ 90-100 PSI (.62-.69 MPa) of compressed air to the primary regulator. If the optional pneumatic vibrator and venturi bag inflator are installed on the IBC-3000, the air requirements would change to a minimum of 10 CFM (283 Liters) @ 90-100 PSI (.62-.69 MPa) of compressed air. The IBC-3000 also has a secondary regulator that is used to regulate the air pressure for the inflatable neck seal. The secondary regulator should be set to 3 to 7 PSI (.02-.05 MPa). Taylor Products recommends that the air supply line be equipped with a refrigerated air dryer, or at the very least a water separator.

## 1.6 Major Systems and Components

When working with the IBC-3000, it is important to understand the major systems and components of the unit.

The standard (non-weighing) IBC-3000 is composed of the following components:

- Main frame
- Inlet flange
- Inflatable bag spout with nylon belt collar
- Adjustable locking strap hangers (bag hangers)
- Pneumatic pressure regulators, primary and secondary.

An IBC-3000 can also be ordered with the following options

- Electronic load cell weighing system
- Inlet flange with 6-inch knife gate
- Control box with machine controls
- T4000 control panel
- T3000 control panel
- Step sequence
- Optional inlets
- Bag liner inflators
- Lift platform
- Lift platform proximity switch
- Settlers
- Drum filling attachments
- Remote bag strap and neck seal release
- Pallet dispenser
- Takeaway conveyor
- Optional control enclosures
- Purge kit

## 1.6.1 Main Frame

The foundation of the IBC-3000 is a very heavy-duty frame that is constructed from 6-inch rectangular steel, with full side channels and 4-inch square tubular steel legs. A standard IBC-3000 frame will accommodate bags that are up to 54-inches in length. The IBC-3000 can be ordered with additional height to accept taller bags.



Figure 1-1. Main Frame

## 1.6.2 Inlet Flange

The IBC-3000 comes standard with a 6-inch inlet flange. This flange does not use a knife gate. An optional 6-inch diameter inlet flange with a pneumatic knife gate is available to control the flow of the product into the container. The IBC-3000 is also available with an 8-inch diameter inlet flange with a pneumatic knife gate, or a 6-inch diameter flange without a knife gate.

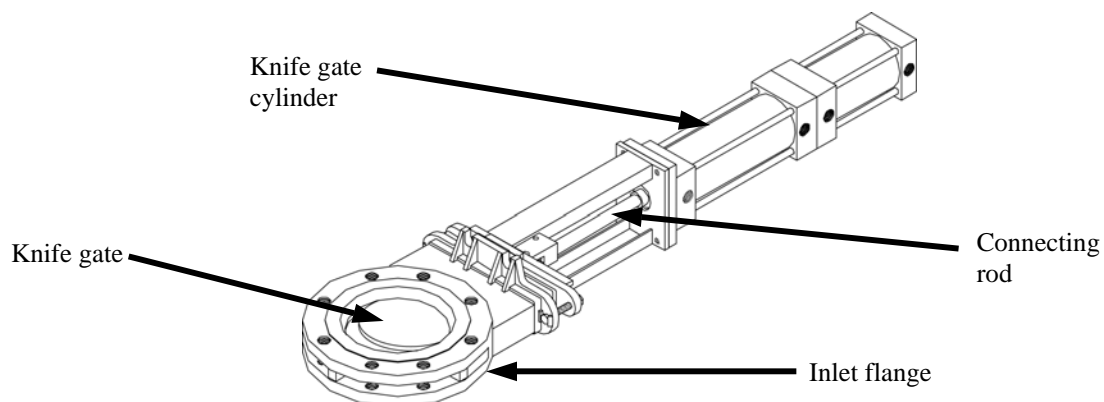
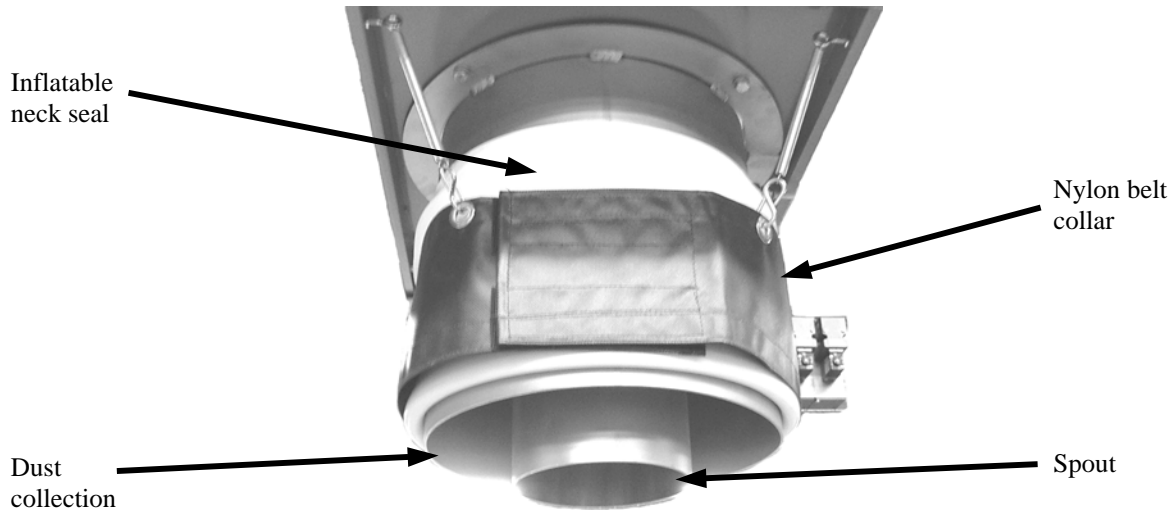

Figure 1-2. Inlet Flange with Knife Gate

### 1.6.3 Inflatable Bag Spout with Nylon Belt Collar

The standard IBC-3000 uses an open mouth bag spout with an inflatable neck seal and nylon belt collar. The inflatable neck seal is used to seal the gap between the bag opening and the spout to prevent leakage of the product and any dust that may exist. The nylon belt collar is used to prevent over inflation of the inflatable neck seal. The spout assembly has an inner and an outer tube. The inner tube is the product feed spout. The outer tube is used for dust collection.



**Figure 1-3.** Inflatable Bag Spout with Nylon Belt Collar

## 1.6.4 Adjustable Locking Bag Strap Hangers

The IBC-3000 is equipped with two sets of adjustable locking bag strap hangers, one on each side of the machine. The hangers are mounted on a piece of metal tubing that is bolted to the main frame. One side of each hanger is fixed, while the other side is hinged, and controlled via a spring and a release rod.



**Figure 1-4.** Adjustable Locking Bag Strap Hangers (one side shown)

The operator pulls the knob on the release rod that is connected to both hangers on one side, to release both hangers on that side. The operator will repeat this process on the other side.

When the operator is ready to hang the next bag, they will place the bag strap over the hanger, then push the hanger up. The hanger will push the release assembly of the hanger assembly out of the way. Once the hanger has been pushed up to clear the locking mechanism, the spring will pull the release assembly back in. The operator can then release the bag strap and repeat for the remaining bag straps.

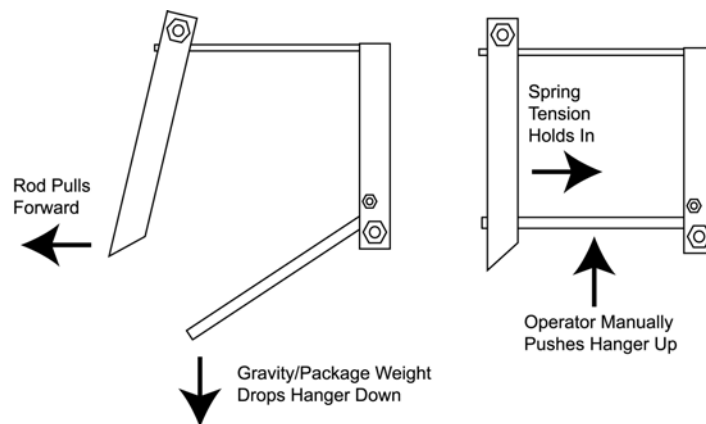

**Figure 1-5.** Operation of the Adjustable Locking Bag Strap Hangers

### 1.6.4.1 Optional Remote Bag Strap and Neck Seal Release

The process of releasing the bag straps at the end of the fill cycle can be streamlined with the addition of the optional remote bag strap and neck seal release feature. This optional feature provides the operator with a one-touch release for the inflatable neck seal and the four bag straps by depressing one push button on the control panel. This option will decrease bag removal time and will increase machine throughput. Pressing the button will apply air pressure to the pair of pneumatic bag strap release cylinders. This will cause the cylinder shafts to extend, thus releasing the straphangers. This process could also be automatically sequenced by the PLC.



Figure 1-6. STRAP RELEASE Button



Figure 1-7. Remote Bag Strap and Neck Seal Release

## 1.6.5 Machine Controls

The IBC-3000 utilizes a control box that is mounted on the side of the machine. The control box has several different variations, based on options ordered by the customer. The variations can be simplified into three categories:

- Non-weighing controls
- T4000 controls
- T3000 controls

### 1.6.5.1 Non-Weighing Controls

A standard, non-weighing IBC-3000 is not equipped with a control panel. However, if the IBC-3000 is equipped with a lift platform or some other option, a control panel will be provided with control buttons and indicators to allow the operator to operate the machine. The non-weighing control panel does not have any provisions for weighing the packages. This control panel comes standard with the following items:

- POWER switch
- POWER ON indicator
- START button
- STOP button/indicator
- UP button
- DOWN button

### 1.6.5.2 Standard T4000 Weighing Controls

The standard weighing configuration includes a T4000 control panel, in addition to the manual controls and indicators to allow the operator to operate the machine. The T4000 is a collaboration between Taylor Products and Hardy Instruments. The T4000 has the ability for total monitoring and instrument control. The T4000 features the following functions:

- LCD screen
- Directional arrow keys
- Enter key
- Function keys

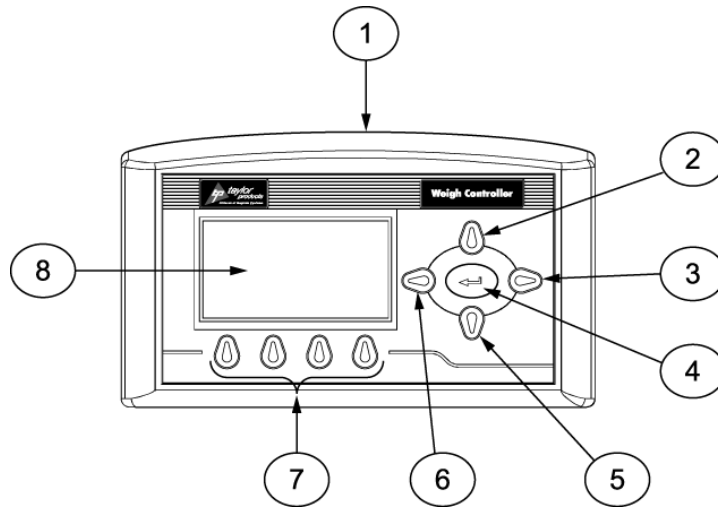

Item #	Description	Item #	Description
1	Control panel	5	Down arrow key
2	Up arrow key	6	Left arrow key
3	Enter key	7	Function keys
4	Right arrow key	8	LCD screen

**Figure 1-8.** T4000 Control Panel

The display has one line of large fonts (5.5 alphanumeric characters), and four lines of smaller fonts (20 alphanumeric characters). The top line displays the currently selected container weight. The remaining four lines are used for monitoring system statuses, historical data, and configuration settings of the IBC-3000.

The T4000 control panel will be housed in a control box with other controls and indicators. The control box contains the following items:

- T4000 control panel
- POWER switch
- POWER ON indicator
- START button
- AUTO / MANUAL switch
- STOP button/indicator

Optional features may also require additional pushbuttons, switches, or indicators. Some examples are:

- PV300 control panel
- MANUAL SETTLER button
- STRAP RELEASE button
- INFLATOR switch
- INFLATOR ON indicator
- SETTLER switch
- SETTLER ON indicator
- UP button
- DOWN button

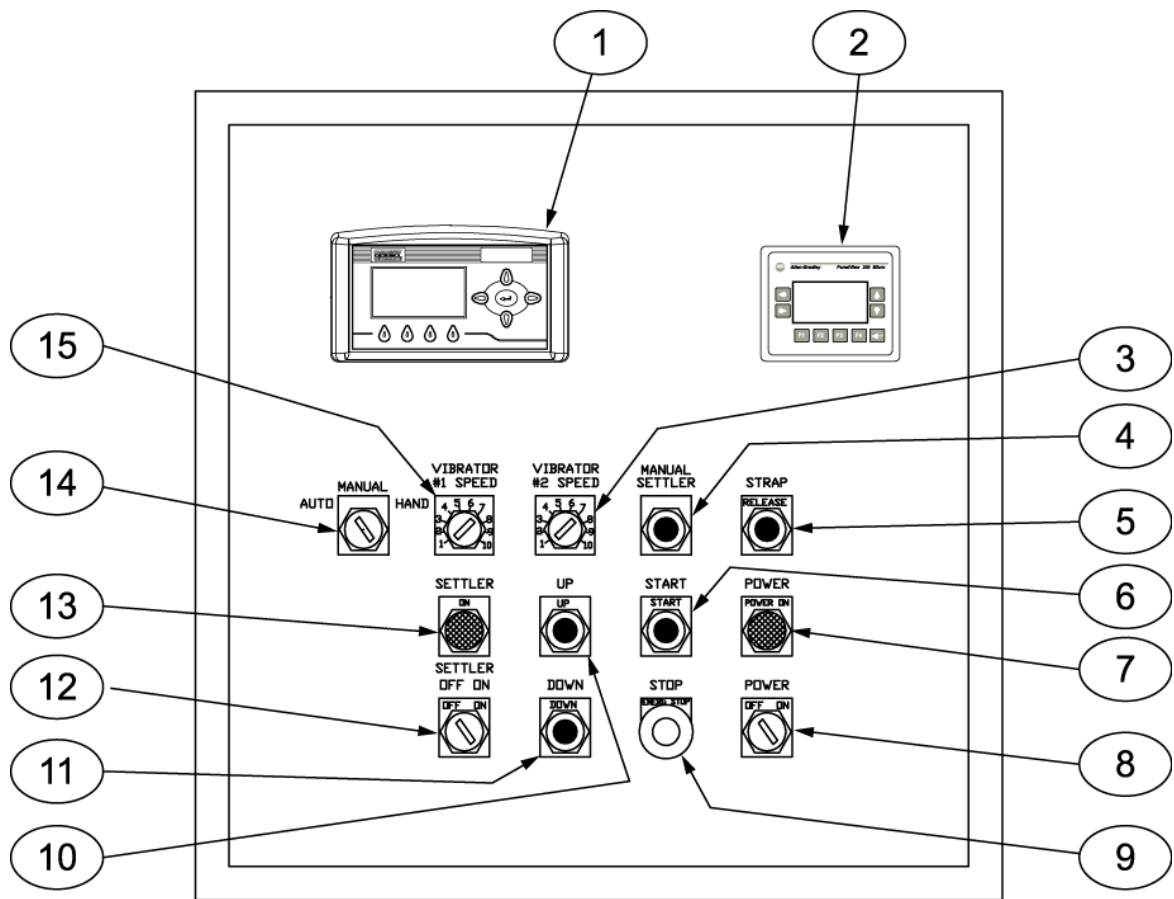

Item #	Description	Item #	Description
1	T4000 control panel	9	STOP button/indicator
2	PV300 control panel	10	UP button
3	VIBRATOR #2 speed control knob	11	DOWN button
4	MANUAL SETTLER button	12	SETTLER switch
5	STRAP button	13	SETTLER ON indicator
6	START button	14	AUTO/MANUAL/HAND switch
7	POWER indicator	15	VIBRATOR #1 speed control knob
8	POWER switch		

Figure 1-9. Sample Standard Weighing Control Box With T4000 Control Panel (Shown with Optional Features)

## General Description

Inside the control box are the other electrical control devices that allow the IBC-3000 to operate. The components inside the panel are:

- Hardy summing board
- Relay board
- Two vibrator control modules (optional)
- MicroLogix™ PLC
- Power supply for the PLC
- Fuse holders

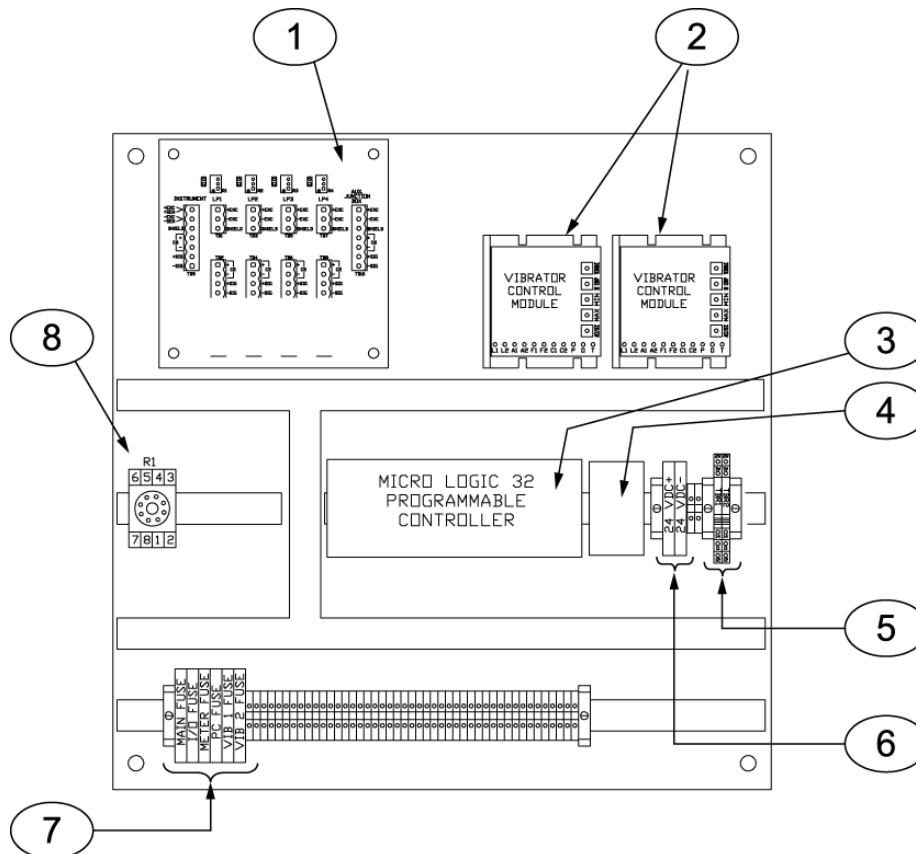

Item #	Description	Item #	Description
1	Hardy summing board	5	DC Terminal Relays
2	Vibrator control modules	6	Fuse holders
3	Programmable logic controller (PLC)	7	Fuse holders
4	Power supply for PLC	8	Relay base

**Figure 1-10.** Inside the Standard Weighing Control Box (Shown with Optional Features)

### 1.6.5.3 Optional T3000 Weighing Controls

The weighing IBC-3000 is available with an optional T3000 control panel. The T3000 is a control panel that has been jointly designed by Taylor Products and Hardy Instruments. The T3000 has the ability for total monitoring and instrument control. The T3000 features the following functions:

- Weight display
- Alphanumeric keypad
- Function keys
- Enter/Exit keys
- Arrow keys
- Infrared (IR) port (not used)

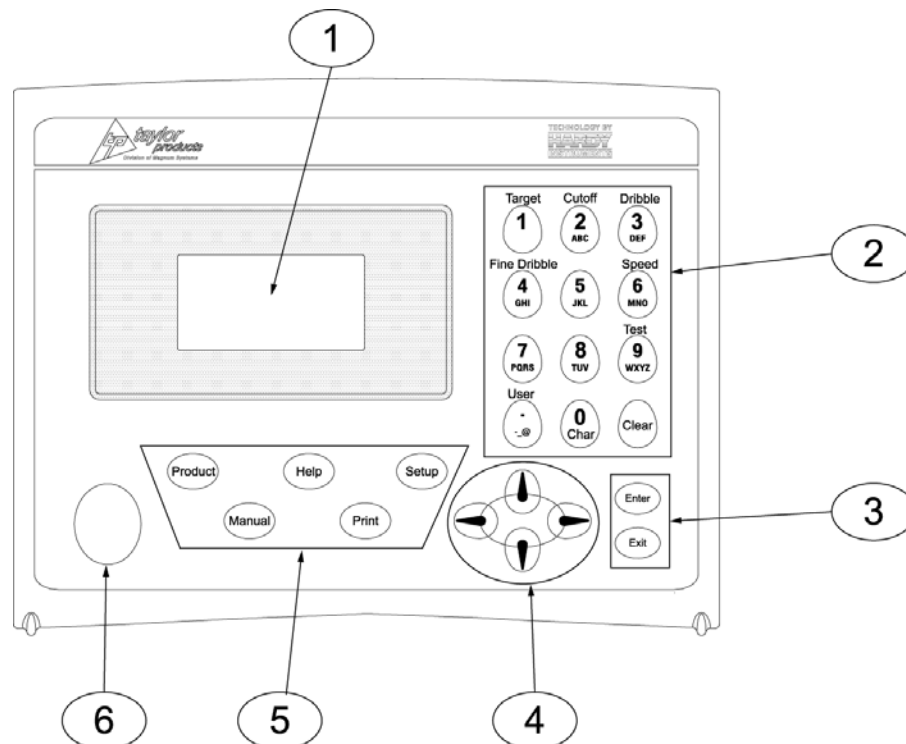

Item #	Description	Item #	Description
1	LCD screen	4	Directional arrow keys
2	Alpha-numeric keypad	5	Function keys
3	Enter and Exit keys	6	Infra Red port (not used)

Figure 1-11. T3000 Control Panel

The front of the T3000 is equipped with a weight display, an alphanumeric keypad, directional arrow keys, function keys, an infrared PDA port (not used), an Enter key, and an Exit key.

The display has one line of large fonts (5.5 alphanumeric characters), and four lines of smaller fonts (20 alphanumeric characters). The top line displays the currently selected container weight. The remaining four lines are used for monitoring system statuses, historical data, and configuration settings of the IBC-3000.

## General Description

The T4000 control panel will be housed in a control box with other controls and indicators. The control box contains the following items:

- T4000 control panel
- POWER switch
- POWER ON indicator
- START button
- AUTO / MANUAL switch
- STOP button/indicator

Optional features may also require additional pushbuttons, switches, or indicators. Some examples are:

- PV300 control panel
- MANUAL SETTLER button
- STRAP RELEASE button
- SETTLER switch
- SETTLER ON indicator
- UP button
- DOWN button

Along with the T3000 control panel, the machine will also have other control and monitoring devices, such as:

- **AUTO/MANUAL switch** – This switch is used to toggle between automatic and manual operation of the IBC-3000.
- **STOP indicator/button** – This is the emergency stop button and indicator. Pressing this button will stop the operation of the IBC-3000 immediately and will cause the button to illuminate RED.
- **START pushbutton** – This button is used to start the operation of the IBC-3000.
- **POWER ON indicator** – This indicator will illuminate GREEN to indicate that the POWER switch is in the ON position and that power is being applied to the machine controls.
- **POWER switch** – This switch is used to turn the IBC-3000 power ON/OFF.
- **PV300 control panel** – Used by the operator to adjust the logical timers that are programmed into the PLC. The timers are used to control several operational features of the IBC-3000. Refer to 4.3.3 PanelView (PV300) Controls for more information.

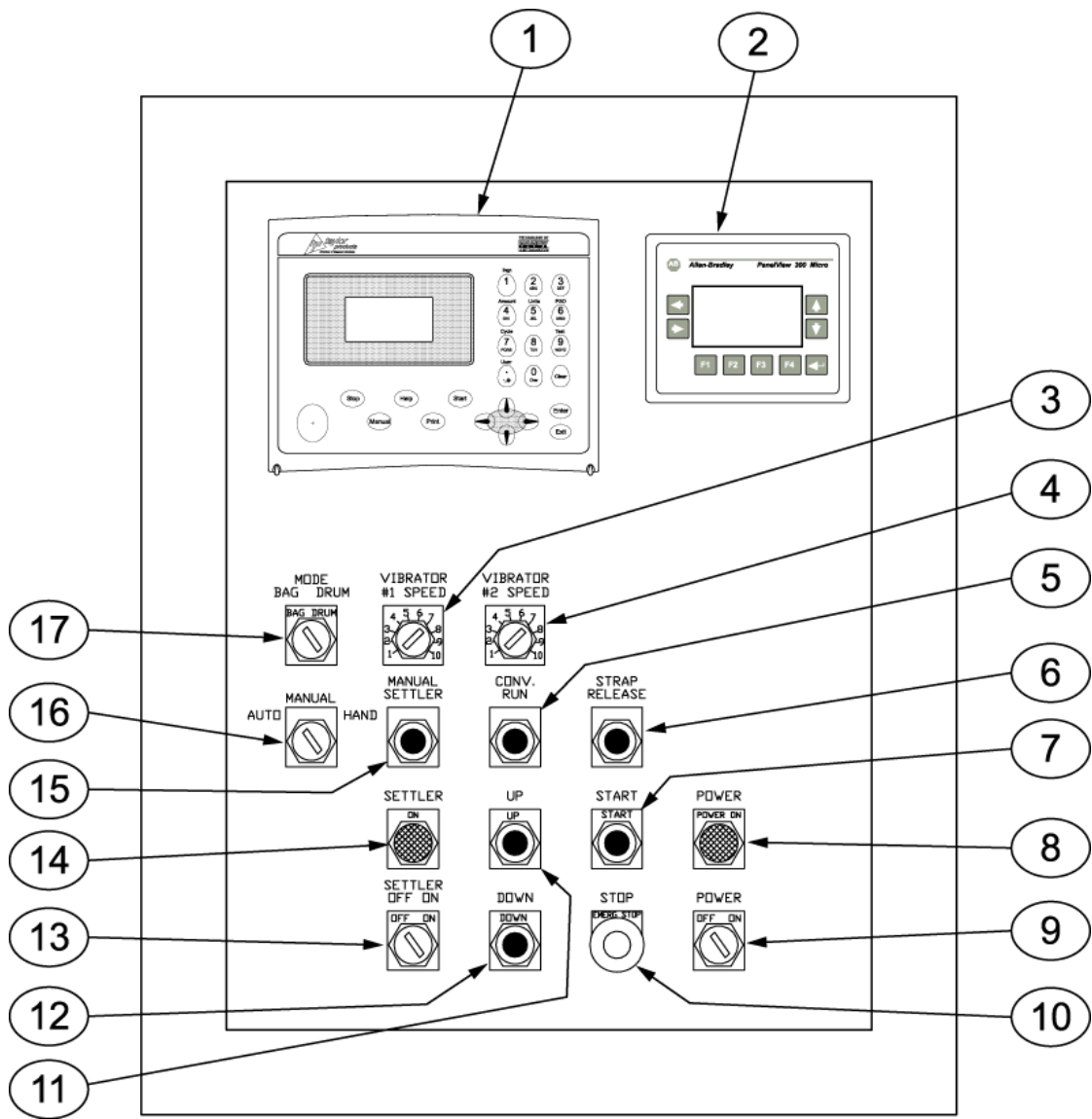

Item #	Description	Item #	Description
1	T3000 control panel	10	STOP button/indicator
2	PV300 control panel	11	UP button
3	VIBRATOR #1 SPEED control knob	12	DOWN button
4	VIBRATOR #2 SPEED control knob	13	SETTLER ON / OFF switch
5	CONV. RUN button	14	SETTLER ON indicator
6	STRAP RELEASE button	15	MANUAL SETTLER button
7	START button	16	MANUAL / AUTO / HAND switch
8	POWER ON indicator	17	MODE BAG / DRUM switch
9	POWER switch		

Figure 1-12. Sample T3000 Control Box

## General Description

Inside the control box are the electrical control devices. The components inside the panel are:

- Hardy interface board
- Two vibrator control modules (optional)
- MicroLogix™ PLC
- Power supply
- Fuse holders
- Relay base

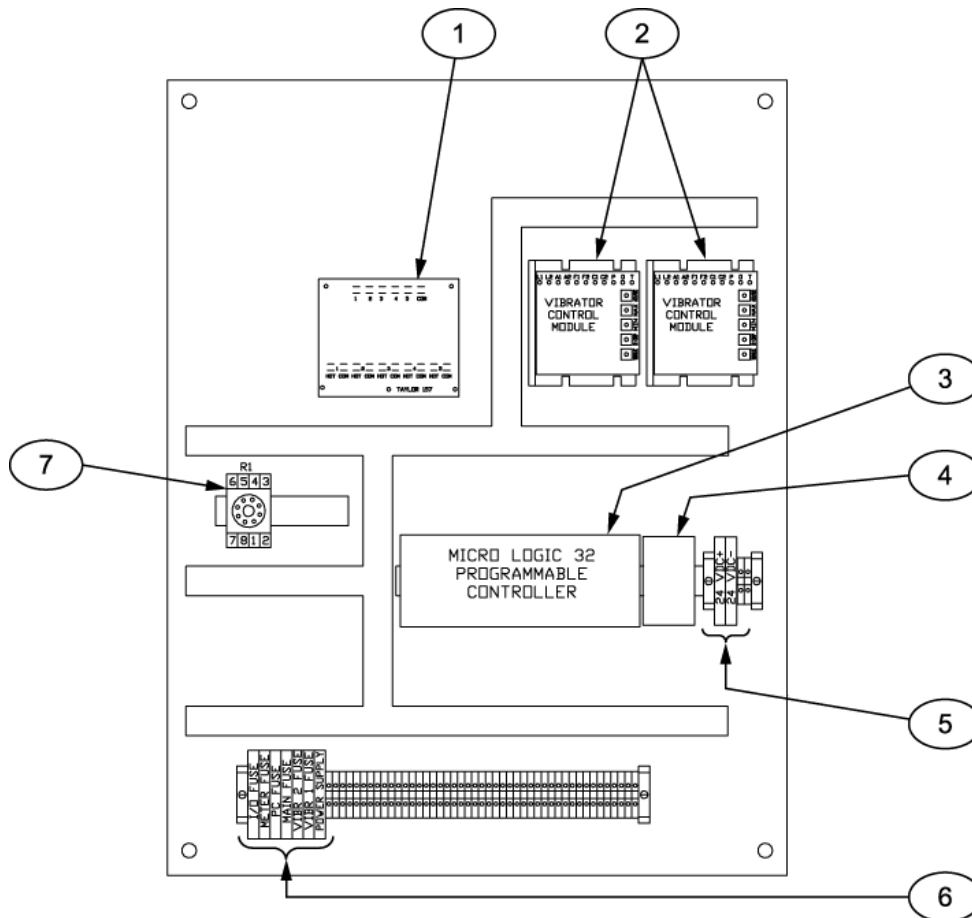

Item #	Description	Item #	Description
1	Hardy interface board	5	Fuse holders
2	Vibrator control modules	6	Fuse holders
3	MicroLogic 32 PLC	7	Relay base
4	Power supply		

**Figure 1-13.** Control Panel with T3000 Control Panel – Internal Components

## 1.6.6 Pneumatic System Components

The IBC-3000 uses multiple pneumatic components to operate. Examples are Filter/Regulator/Lubricator (FRL) assembly, stand-alone pressure regulators, MAC valves, and pneumatic cylinders.

### 1.6.6.1 Pneumatic Pressure Regulators

Depending on how the IBC-3000 is equipped, the unit will have at least two, and possibly more pneumatic pressure regulators. The primary regulator will be a Filter/Regulator/Lubricator (FRL) assembly. This unit filters the incoming compressed air, regulates its pressure, and adds a lubricant to the air that provides lubrication to the pneumatic internal components of devices that are downstream. A second pressure regulator is used to adjust the pressure for the inflatable neck seal on the spout down to 0-15 psi.

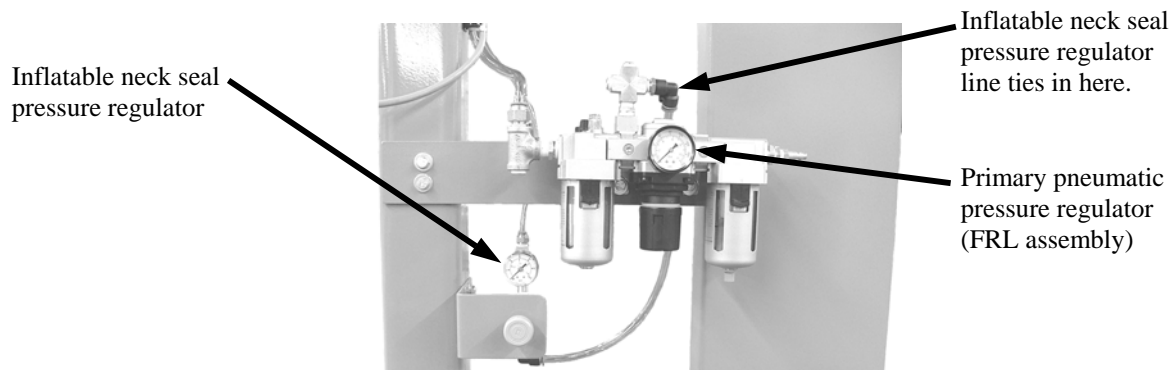

**Figure 1-14.** Pneumatic Pressure Regulators

### 1.6.6.2 MAC Valves

There are several MAC valves that are mounted on the inside of the upper rear cross support of the IBC-3000. These valves are used to control the compressed air supply to various pneumatic components on the IBC-3000, such as the knife gate and the platform lift cylinders.

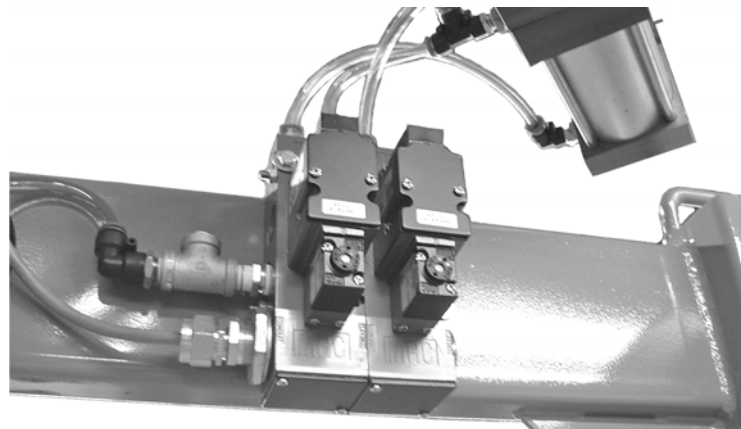
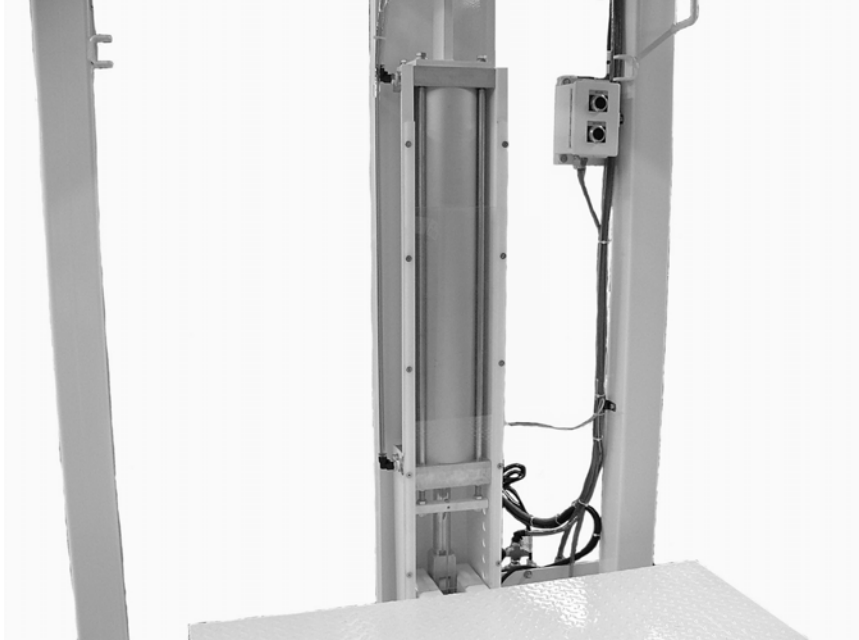

**Figure 1-15.** MAC Valve Mounting Location

## General Description

### 1.6.6.3 Platform Lift Cylinders

When equipped with a lift platform or lift/weigh platform, the IBC-3000 will have two large pneumatic cylinders. One cylinder will be installed on each side of the platform. When the UP button is pressed, the cylinders will raise the platform. When the DOWN button is pressed, the cylinders will lower the platform.



**Figure 1-16.** Platform Lift Cylinder (1 of 2 shown)

### 1.6.7 Electronic Load Cell Weighing System

IBC-3000 units that are equipped for weighing utilize three electronic load cells that are arranged in a triangular pattern. The load cells produce a voltage based on the amount of load that is placed on them in a linear fashion. There are two load cells installed on the front of the unit, at the outer edges, while the third load cell is installed on the rear of the unit in the center. This weighing system utilizes a summing technique to balance the signals from the three load cells. This technique allows imbalanced loads to be weighed accurately.

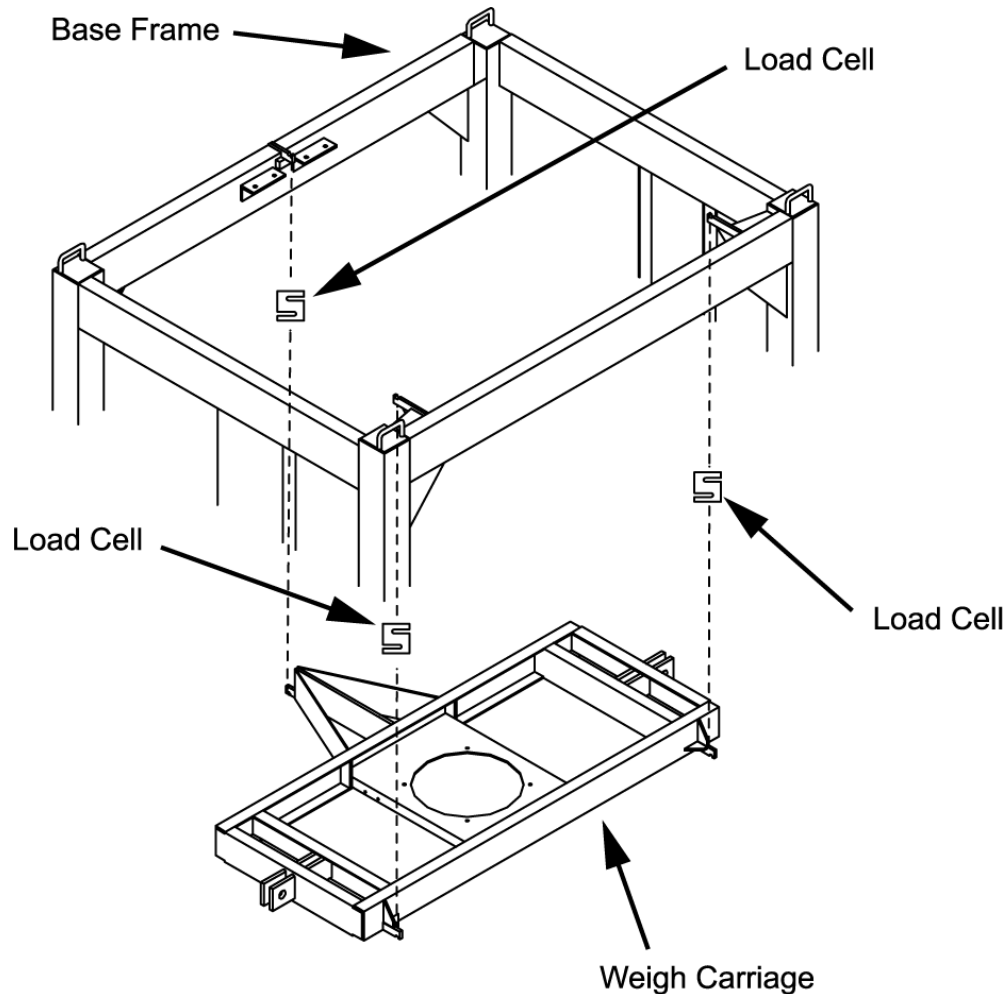
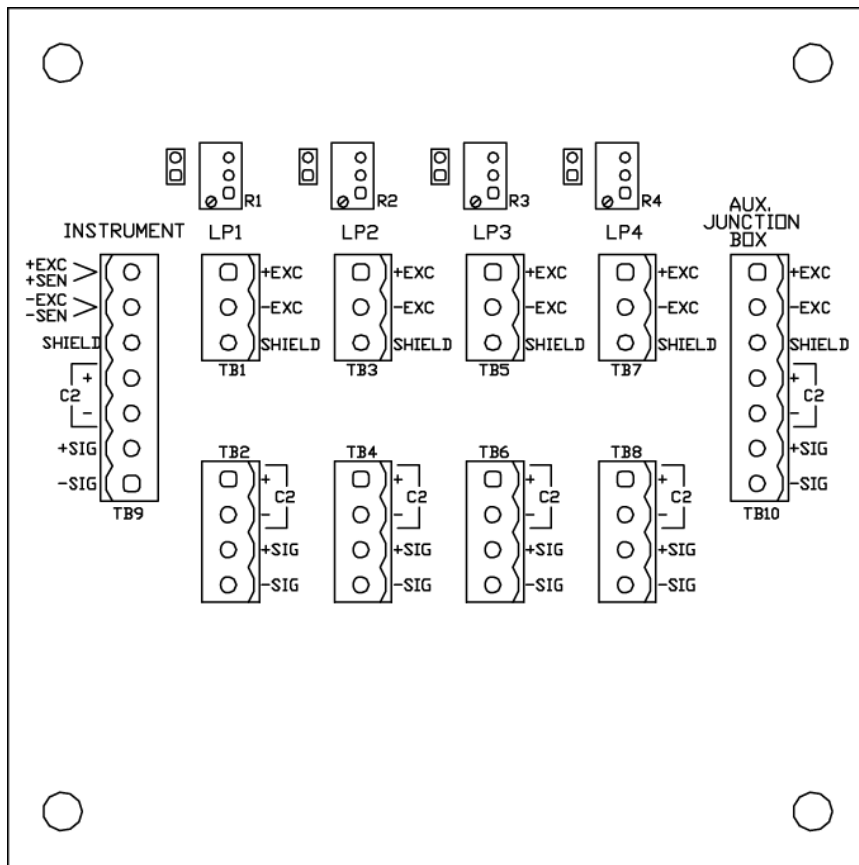

Figure 1-17. Load Cell Arrangement

### 1.6.7.1 Load Cell Connections with T4000 Control Panel

If the IBC-3000 is equipped with T4000 controls, the summing technique is accomplished using the Hardy Summing Board that is installed inside the control panel.



**Figure 1-18.** Hardy Summing Board

The load cells will be connected to the Hardy Summing Board. For example, load cell 1 will be connected to TB1 and TB2. The +EXC, -EXC, and SHIELD leads will be connected to TB1, while +SIG and -SIG will be connected to TB2. Load cell 2 will be connected to TB3 and TB4, while load cell 3 will be connected to TB5 and TB6.

### 1.6.7.2 Load Cell Connections with T3000 Control Panel

If the IBC-3000 is equipped with a T3000 control panel, the Hardy Summing Board would not be installed. With the T3000, the Junction Box card that is installed in the T3000 is responsible for summing the inputs from the load cells. The load cells are connected to the Channel 1, Channel 2, and Channel 3 ports on the junction box card. These connections are located inside the control box on the rear of the T3000.

Detailed operation of the T3000 control panel is covered in detail in the T3000 Electronic Weigh Controller Quick Reference Guide, available from Taylor Products.

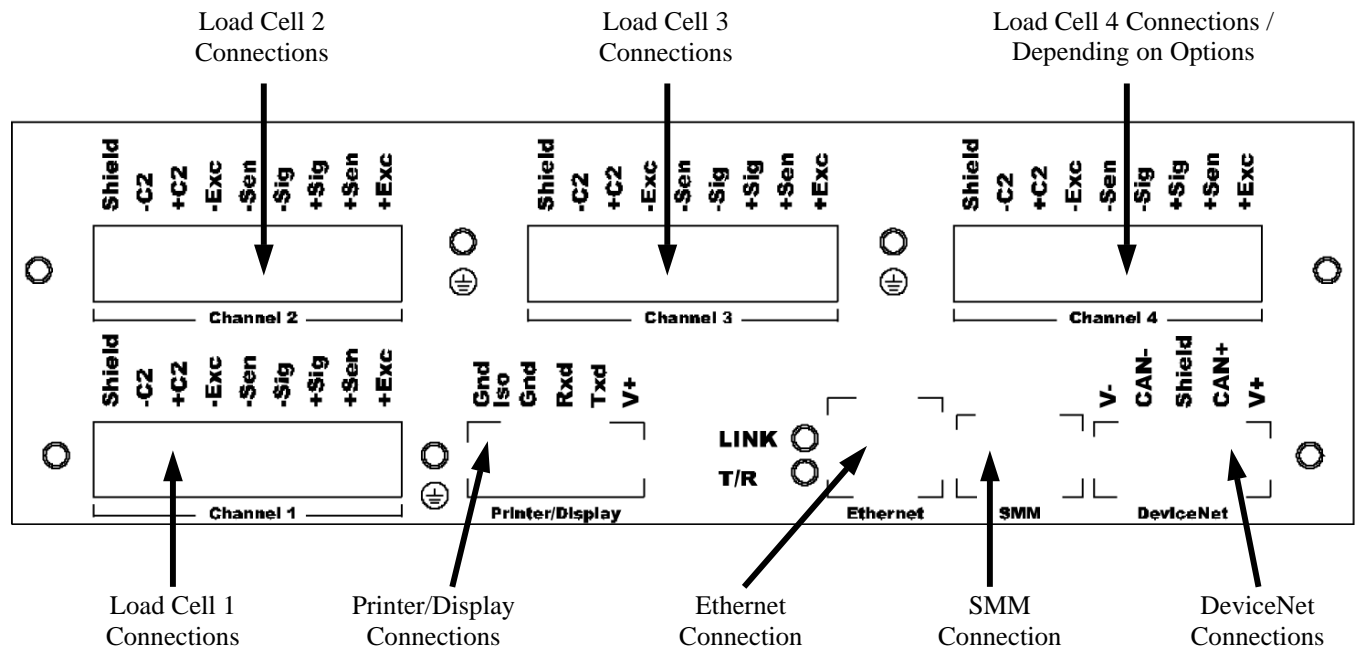

Figure 1-19. T3000 Junction Box Connections

### 1.6.8 Step Sequence

The Step Sequence is available when the IBC-3000 is equipped with a lift platform. This option is used to raise the lift platform to a preset level so the operator can easily hang the bag straps.

## General Description

### 1.6.9 Bag Liner Inflators

An optional bag liner inflator allows the operator to pre-inflate the bag to allow for easier filling. There are two options available. One option is a self-contained inflator that requires the installation of a blower motor, control switches/buttons, and associated ductwork, while the other uses plant supplied compressed air.

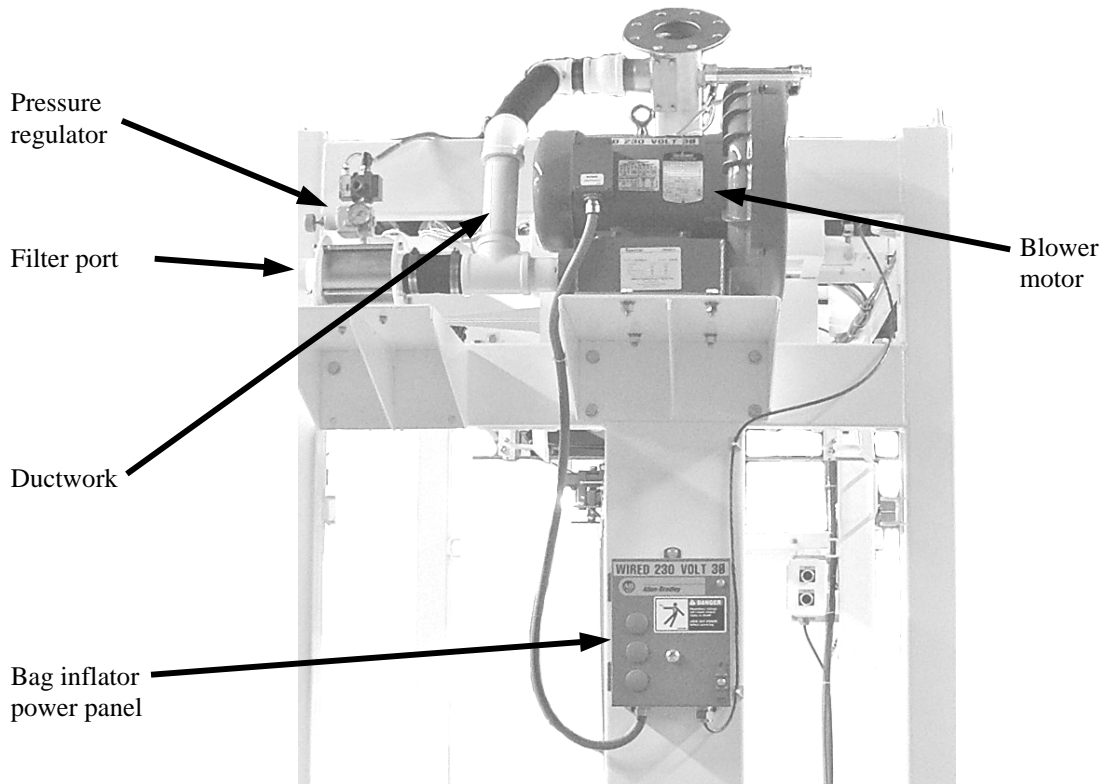
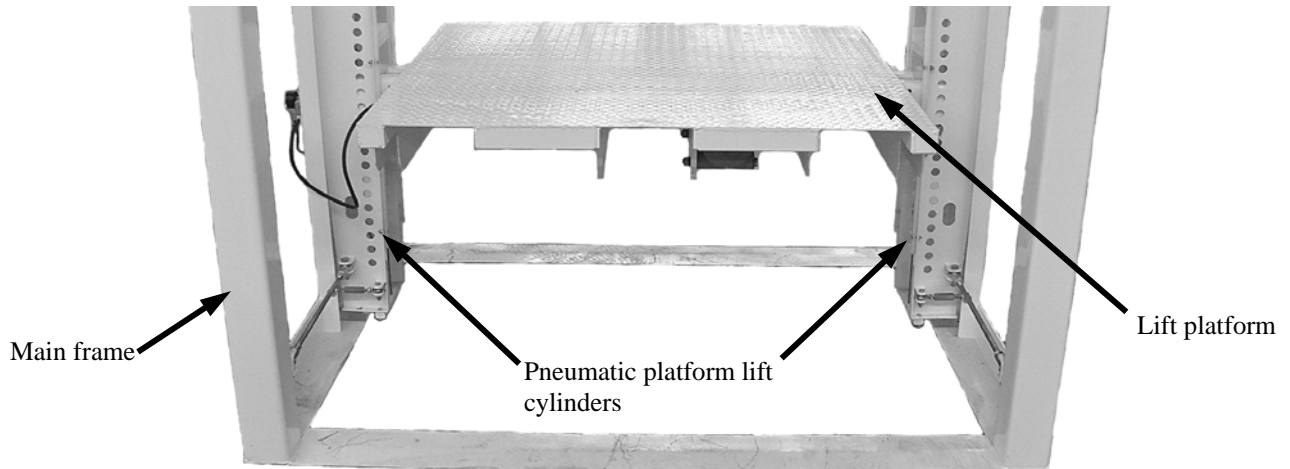

Figure 1-20. Self-Contained Bag Liner Inflator

### 1.6.10 Lift Platform

The IBC-3000 is available with an optional lift platform. The lift platform serves several functions. It is programmed to lift and square the bottom of the bag during the fill cycle. It houses the vibration capability. It provides the lift, unhook, and lower capability for safer bag handling. In addition it is suspended from the weigh carriage making it the weigh platform when filling boxes, drums or Gaylord containers. There are two types of platforms available. A standard platform is a square platform that is constructed of metal square tubing base with a painted diamond plate platform. The standard platform requires the operator to manually load new pallets and to manually remove completed pallets from the platform using a forklift.



**Figure 1-21.** Standard Lift Platform

When the IBC-3000 is equipped with an optional chain pull conveyor system, which can be used to bring in empty pallets and to take away completed pallets, a different lift platform must be used. The platform must provide relief for the chain pull conveyors that will protrude inside the perimeter of the frame on both the intake and discharge sides of the IBC-3000. The platform will have either two or three notches per side, depending on the type of chain pull conveyor used. This permits the conveyors to provide a seamless transition of both empty and full pallets. Refer to 1.6.15 Conveyors, for more information.

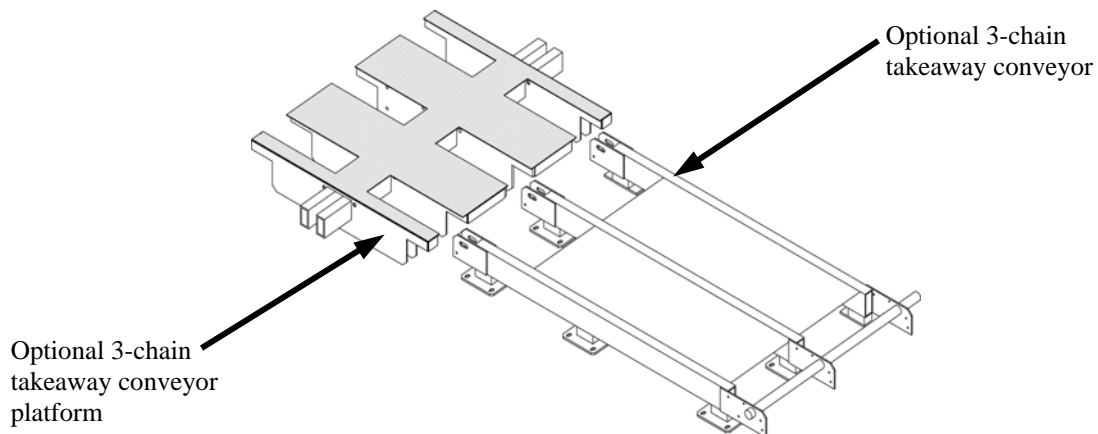

**Figure 1-22.** Optional Takeaway Conveyor Platform

### 1.6.10.1 Lift Platform Cables

The IBC-3000 utilizes a system of pneumatic cylinders, pulleys, and cables to raise and lower the lift platform. The pulleys are used to guide the lift platform as the pneumatic cylinders raise and lower the platform. There are two sets of pulleys on each side of the platform. The each set of pulleys is installed so that they are in line with each other. For proper operation of the two cables must run parallel to one another. If they are crossed, it will cause binding, and the motion of the lift platform will be inhibited.

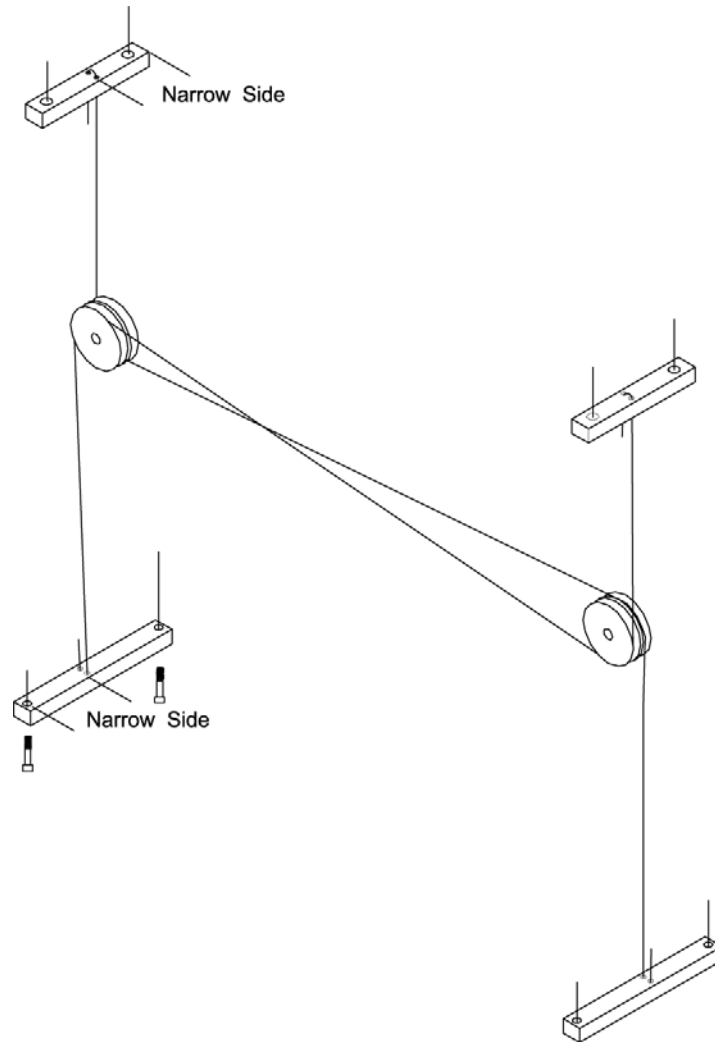
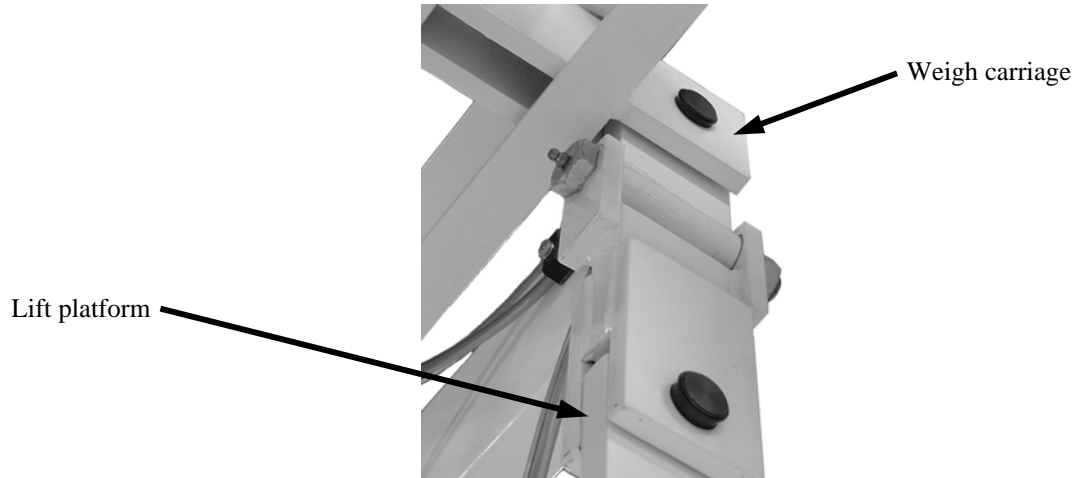

Figure 1-23. Lift Platform Cables

### 1.6.11 Lift/Weigh Platform

For applications where drums, boxes, or Gaylord containers are being filled and weighed, the Lift/Weigh option is required. This option ties the lift platform into the weighing system.



**Figure 1-24.** Lift Platform Connection to the Weigh Carriage Frame

### 1.6.12 Settlers

The IBC-3000 can be ordered with either single unit pneumatic or electronic product settlers. These devices use high amplitude vibration to assist the product settlement in the container. The settlers are mounted on the bottom side of the platform, and are installed in pairs. One will be installed on the front side of the platform, while the other is installed to the rear of the platform.

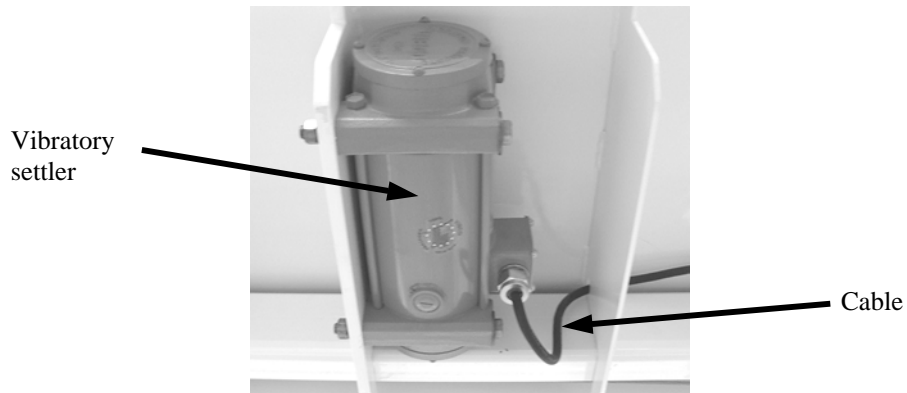

**Figure 1-25.** Electronic Vibratory Settler (1 of 2 used)

### 1.6.13 Drum Filling Attachments

The IBC-3000 is available with a drum filling attachment that uses an articulating arm with a flexible spout and position lock. Multiple containers can be filled using an articulating arm with a flexible spout and position lock. The lift/weigh platform option is required for multi-tasking bag, drum and box applications.



**Figure 1-26.** Drum Filling Attachment

### 1.6.14 Pallet Dispenser

An optional pallet dispenser can be linked to the IBC-3000. The pallet dispenser is used to supply empty pallets to the IBC-3000 for loading. Typically, a pallet dispenser can hold eight or more empty pallets.

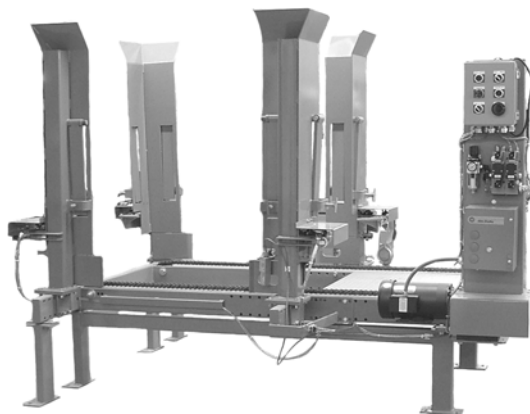
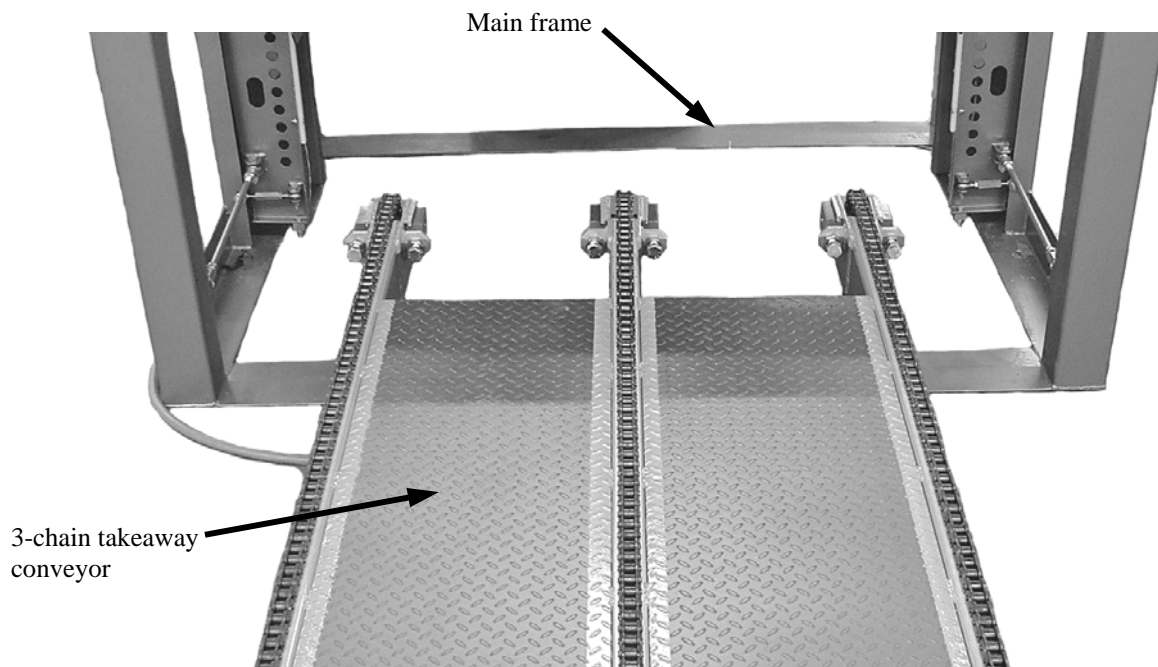

**Figure 1-27.** Pallet Dispenser

Pallet dispenser operation, maintenance, troubleshooting, and repair information is covered in detail in a separate manual.

### 1.6.15 Conveyors

The IBC-3000 can be ordered with a chain pull conveyor to bring in new pallets, and/or a takeaway conveyor to take completed pallets away. Conveyors are available as either two or three chain models. Conveyors can be configured to accommodate up to four pallets. This helps to enable continuous production while finished containers are closed and transferred to storage. This option requires a special lift platform that is notched to allow the chain pull conveyors to protrude inside the exterior perimeter of the IBC-3000. Refer to 1.6.10 Lift Platform for more information.



**Figure 1-28.** Optional Takeaway Conveyor (3-Chain Version Shown)

## General Description

### 1.6.16 Purge Kit

The IBC-3000 can be ordered with an optional Purge Kit. There are four different choices for Pepperl+Fuchs' Bebeco EPS System Purge Kits:

- Class I, Division, I Group C&D (Model 2001 STD-CI-CB-TM-X)
- Class I, Division, II Group C&D (Model 1002 WPS-CI-Z-TM)
- Class II, Division, I Group F&G (Model 2001 STD-CII-CB-TM-X)
- Class II, Division, II Group F&G (Model 1001A STD-CII-Z-TM)

The Purge Kit is used to prevent combustible dust accumulation or remove and prevent flammable gas or vapor accumulations. Basically, this system utilizes a protected enclosure that is equipped with an intake port and exhaust port. The system is designed to allow an inert gas, or instrument quality air, to pass through the protected enclosure. The flow of the inert gas or air picks up any flammable dust or gasses and carries them away. This is done while maintaining a pressurized (.25 psi) environment within the protected enclosure. For more detailed information on the Purge Kit, refer to the Model 1001A, Type Y or Z, Pressurization/Purging System Installation & Operation Manual, in Appendix G of this manual.



Figure 1-29. Purge Kit

## Chapter 2

# Receiving Equipment

### 2.1 General Description

The IBC-3000 and all of its components are thoroughly inspected before shipment. Immediately upon receiving the equipment, inspect each unit carefully to make sure each item is in good condition and that all items on the packing list have been received. Each unit has been packaged for protection during normal shipping and handling. However, it is possible that the equipment has been damaged in transit. Note any damages or shortages on the Bill of Lading. Immediately file damage reports and damage claims with the Carrier. Any and all damage to the equipment that occurs in transit is the responsibility of the Carrier, as it is the Manufacturer's (Taylor Products) standard policy to ship all equipment F.O.B. from our factory. This means that ownership of the equipment changes from the Manufacturer to the Purchaser, at the time the Carrier loads and accepts the equipment. Therefore, any claims for losses or damages that occur in transit must be made to carrier by Purchaser.

### 2.2 Uncrating the Equipment

Follow the steps below to uncrate the IBC-3000.

**WARNING**

*Use care when unpacking the IBC-3000 to avoid damage to any hinged parts and external controls. Grasp the IBC-3000 by the Main Frame to handle.*

*Blunt trauma, strain, and torque can cause load cell failure!*

---

---

1. The IBC-3000 should be installed on a level concrete floor in a cleared area that is at least 12' x 12'. Additional space will be required when lifting the machine into position. Some available options will require more space. Taylor Products recommends that the machine be placed in a manner that will allow 4' of space around the machine on all sides.

**Important:** *It is recommended that the IBC-3000 be located directly under the supply hopper. Complete any nearby construction before installing the IBC-3000.*

2. Upon receiving the shipment, inspect the crate for any visible damage. Pry the crate open, using a crowbar.

**Important:** *Before removing the IBC-3000 from the shipping pallet, inspect IBC-3000 for visible damage. Inspect for damaged or missing parts. If there is damage, notify the shipper and Taylor Products immediately.*

3. Cut the metal bands. Remove the lag bolts from the main frame at pallet.
4. Remove and discard all of the crating material.
5. Remove the platform stabilizer brackets.
6. Using the lifting points on the top of the main frame, lift the main frame to an upright position.

## Receiving Equipment

7. Check to make sure that the IBC-3000 is balanced using the lift points on the top of the main frame.



### CAUTION

Care must be taken when lifting the IBC-3000 to make sure that a good balance point is used. If a good balance point is not found and used, the IBC-3000 could tip over while moving it, causing severe damage to the machine and it could result in severe bodily injury or even death to any persons around it.

8. Position the IBC-3000 directly under the centerline of the surge hopper, downspout, etc.
9. Align the IBC-3000 in the direction of the bulk bag discharge.
10. Confirm that the IBC-3000 is level. If the floor is not level, use shims to ensure positive contact between the floor and the main base.
11. Anchor the base angles to the floor, using anchors or expansion bolts for added stability.
12. Loosen the hinge bolts on the control panel swing arm.
13. Rotate the control panel out to its operating position and tighten the hinge bolts.
14. Loosen the shipping bracket bolts on the weigh carriage.



**Figure 2-1.** Shipping Bracket

15. Use one hand to hold the shipping bracket while removing the shipping bracket bolts from the frame.
16. Remove the shipping bracket.
17. Remove the nut and washers from one end of the threaded rod that is on the opposite side of the spout from where the shipping bracket was mounted, and slide the threaded rod out.

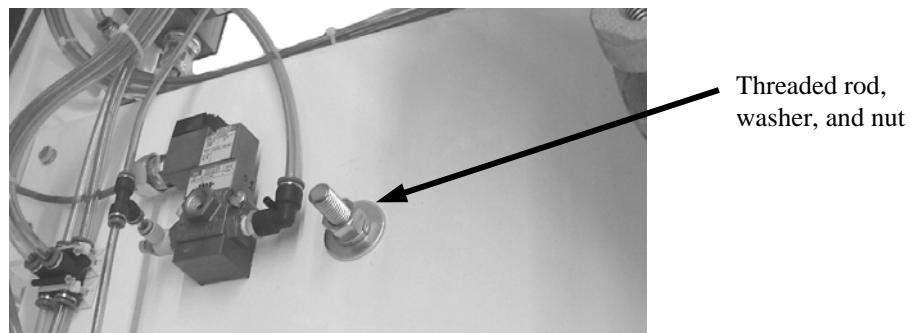

**Figure 2-2.** Threaded Rod Used to Lock the Weigh Carriage During Shipping

## Chapter 3

### Setup/Installation

#### 3.1 General Description

Only properly trained/qualified personnel should attempt to install, operate, or maintain this equipment.

**WARNING**

*Before installing, adjusting, or servicing any electrical component, be sure to become familiar with the electrical schematic for the machine.*

---

**WARNING**

*Before installing, adjusting, or servicing any pneumatic component, be sure to become familiar with the pneumatic schematic for the machine.*

---

#### 3.2 Making Electrical Connections

Before connecting power to the IBC-3000, it is vital that it be properly grounded. Taylor Products recommends connecting the machine to an earth grounded receptacle. The IBC-3000 comes equipped to operate on power ranging from 115 VAC to 240 VAC at 50 or 60 Hz. The electrical outlet should be placed within 6-feet of the IBC-3000.

Refer to the electrical schematics in Appendix D for exact current and voltage specifications. Contact Taylor Products with any questions.

#### 3.3 Making Pneumatic Connections

The IBC-3000 uses approximately 3-10 CFM (85-283 liters per minute) @ 90-100 PSI (.62-.69 MPa) of compressed air to the primary regulator. When the optional pneumatic vibrator and/or venturi bag inflator are installed, the air requirements would change to a minimum of 10 CFM (283 Liters) @ 90-100 PSI (.62-.69 MPa). A secondary pressure regulator is used to regulate pressure to the inflatable neck seal. The secondary regulator should be set to 3 to 7 PSI (.02-.05 MPa).

Taylor Products recommends the air supply line be equipped with a refrigerated air dryer, or at the very least a water separator. After making pneumatic connections, check all connectors for leaks using a soapy water mixture. Bubbles indicate a leak. Eliminate leaks to reduce air supply equipment wear.

Refer to the pneumatic schematics in Appendix D when working on pneumatic components. Contact Taylor Products with any questions.

##### 3.3.1 Lubrication Requirements

The pneumatic cylinders require lubrication to ensure their proper operation and to extend their useful life. The lubricator should be filled with 10 or 20 weight, non-detergent oil.

The oil flow control knob, located on top of the lubricator, should be set so that the lubricator is delivering 1 drop of oil for every 15 to 20 bags that are filled.

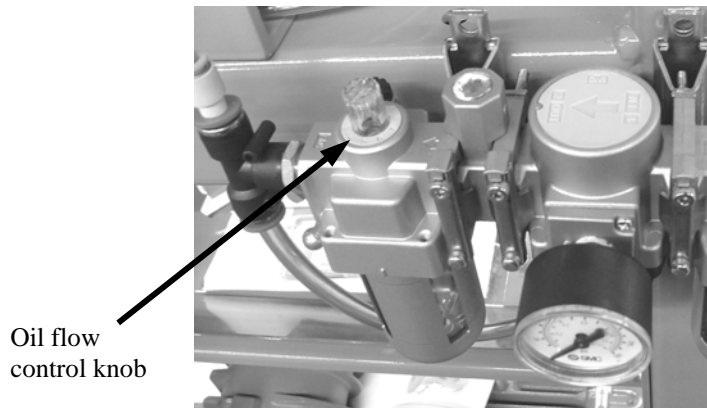

**Figure 3-1.** Lubricator – Oil Flow Control

Use caution when setting the flow control on top of the lubricator. While too little oil can cause operational problems, so can too much oil. If the oil control is set too high, it may result in the solenoid valves and cylinders getting gummed up and the air supply lines.

### **3.4 Mechanical Setup**

After placing the IBC-3000 where it will operate, setup the mechanical components for operation.

1. Check the frame of the IBC-3000 to make sure it is level. Use shims under the legs if necessary. If the frame is not level, the performance of the IBC-3000 will be adversely affected.
2. Check the weigh carriage for level. If necessary, adjust the weigh carriage angle by adjusting the rod ends on the load cells. A non-level weigh carriage may lead to inaccurate weighments.

### **3.5 Making Network Connections**

IBC-3000 units that are equipped with the optional T3000 control panel have the ability for total monitoring and instrument control via the built in communication connectivity of the T3000. The T3000 has the following network capabilities:

- DeviceNet
- HardyLink Ethernet
- IR Port
- RS-232 Simplex Serial Port
- Remote I/O (RIO) (optional)
- ControlNet (optional)
- Profibus I/O (optional)
- Modbus over TCP/IP (optional)
- OLE Process Control (OPC) (optional)

Refer to the Hardy Installation and Service Manual for information on cabling.

## 3.6 Establishing Security Settings

On IBC-3000 machines that are equipped to weigh, the manager has the ability to control who does and who does not have the ability to change certain parameters. While both the T4000 and T3000 control panels have this capability, the method of setting security parameters is different for each type of control panel.

### 3.6.1 Establishing T4000 Security Settings

The Security parameters allow management to place security on the instrument and any menu or sub-menu requiring a password before enabling any changes. The Change Security parameter enables all persons to see the security status for a given menu, and selected persons to change that security status for any menu.

1. From the Configuration menu press the down arrow until the cursor is in front of Security.

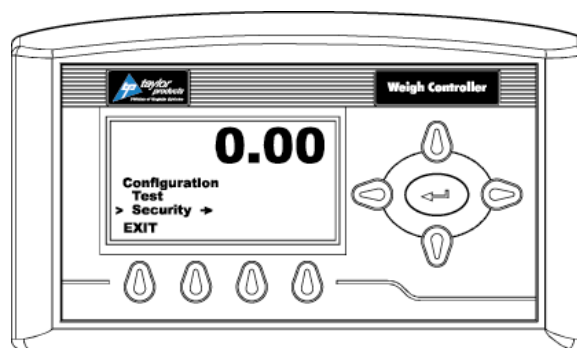

Figure 3-2. Placing The Cursor In Front Of Security

2. Press the Enter key. The Security menu appears.
3. Set the Password Parameter. The Set Password parameter enables the operator to create a password for entry to secure menus and sub-menus. If the password is 0 there is no security. If the password is anything other than 0 the security is enabled.

*Note: It is recommended that the passwords be created before setting security on the various menus.*

4. Press the down arrow button until the cursor is in front of Set Password.
5. Press the Enter key.

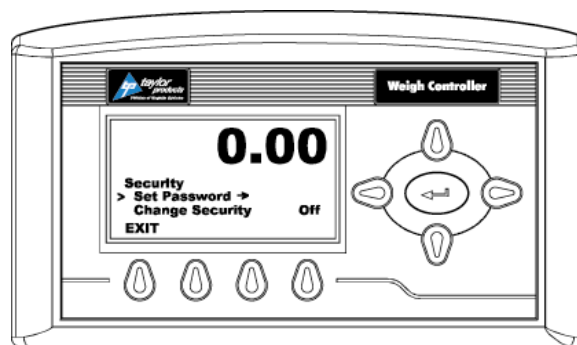

Figure 3-3. Placing The Cursor In Front Of Set Password

## Setup/Installation

6. If the password is being set for the first time or if the factory defaults have been reset in the Test menu, enter the default password “2205”. If the password is being reset, and the existing password is known, enter that number. Press the Enter key. The Verify Password display appears.
7. Press the Enter key. If the password is correct a brief message “Entry Accepted” appears and the Set Password display with the current password appears.

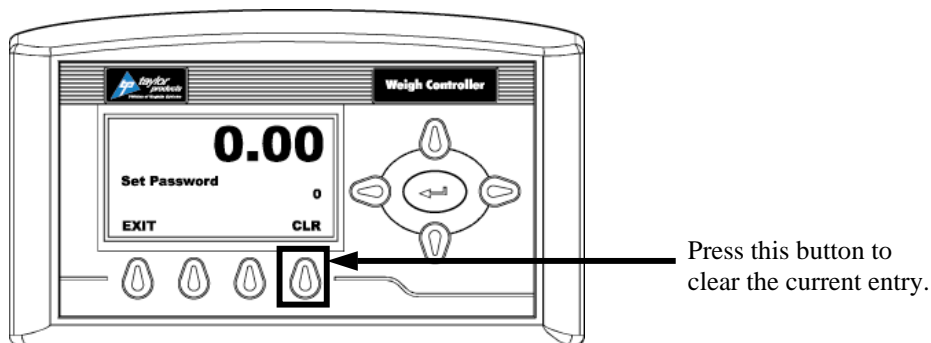

Figure 3-4. Set Password Menu

8. Press the function button located directly below the CLR item on the display to clear the entry. Use the left or right arrow buttons to move the cursor left and right. Use the up or down arrow buttons to enter the password number. To delete a single entry, press the left arrow button. In the example below, “123” was entered.

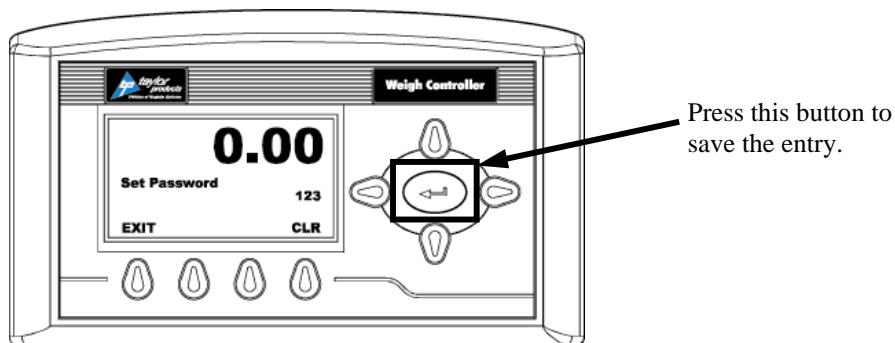

Figure 3-5. Password Set To 123

9. Press the right or left arrow buttons to toggle Change Security On. The Verify Password display appears.

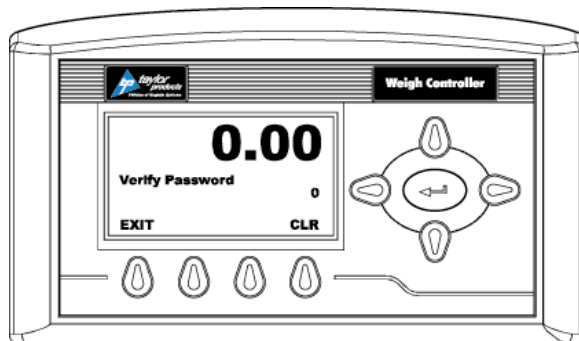

Figure 3-6. Verify Password

- Use the left or right arrow buttons to move the cursor left and right. Use the up or down arrow buttons to enter the password number.

**Important:** When entering the password, the last digit is entered first, then the next digit to the left and so on. For example, if the password is set to 123, then 3 is entered first, then the 2, and the 1 is entered last.

- Press the Enter key. The Change Security status changes to On. In this instance we turned Change Security ON because we want to change the security of a sub-menu.
- Now that the Change Security On feature has been turned on, press the function key below the word EXIT on the display to return to the Configuration menu.
- Use the up or down arrow buttons to go to the desired sub-menu to be secured. In the example below, the Decimal Point sub-menu has been selected. Notice that the display now includes a SECUR menu item above the function keys.

**Note:** Steps 8-12 will need to be repeated to lock and unlock a parameter.

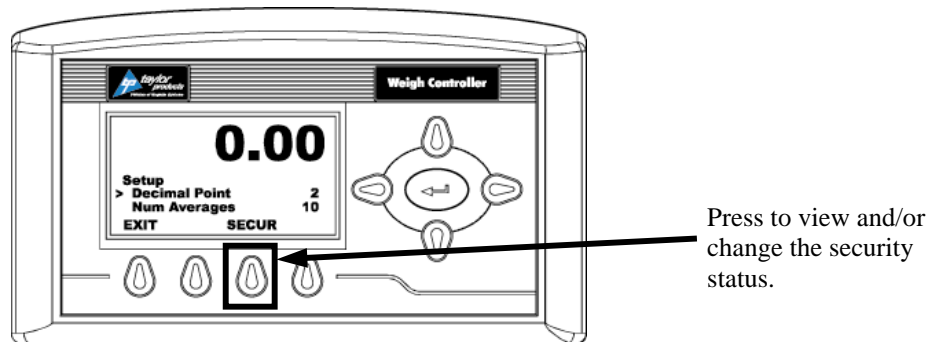

Figure 3-7. SECUR Menu Item Shown Above Function Key

- Press the function key that is positioned below the SECUR item on the display, to view and/or change the security status of this parameter.
- Press the right arrow button to changed to LOCKED thereby securing this sub-menu.

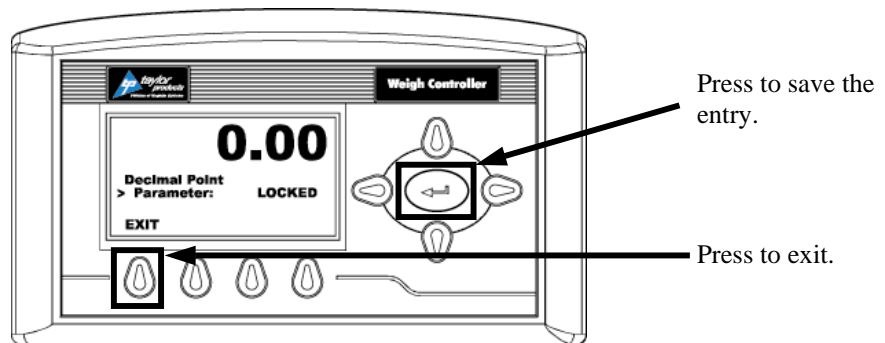

Figure 3-8. Parameter Shown Locked

- Press the Enter key to save the entry.
- Press the function button below EXIT on the screen until the summary display is shown.

**Note:** To check to see if the security is set on a specific sub-menu, press the EXIT button until the summary display appears. Then re-enter the menus and try to change the secure parameters.

## Setup/Installation

18. Until security has been changed, changing this parameter will require a password (other than 0) to be entered.
19. To turn the Change Security OFF, go back to the Security menu and repeat steps 1-6.

### 3.6.2 Establishing T3000 Security Settings

The T3000 software application provides the security capability so the manager can set the security levels for each Top-Level menu. Each Top-Level menu is set to Low as the default, but their level of security can be adjusted. These menus are:

- Product Select
- Adjust/Setup
- Calibration
- Options
- I/O Mapping

There are additional menu choices that can have their security levels changed. The menus are:

- Controls
- Local Alarm Clear
- Test

There are three menus that are reserved for supervisors, engineers, or service personnel. The three menus have their security level set to HI and the level cannot be changed. These menus are:

- Security Menu
- Application Type Menu
- Factory Default Menu

After the controller has been configured or calibrated, Taylor Products recommends that the menus be secured by setting their security level to Medium or High. This will considerably reduce the possibility of problems that might arise from unauthorized personnel changing critical control parameters. Changing these parameters may result in catastrophic system failure or in operational instability.

- Low – No password required.
- Medium – A password is required to access some, but not all of the top level menus. The factory-preset password for this level of security is 7878.
- High – A password is required to access all top-level menus. The factory-preset password for this level of security is 1232.
- If a menu has a Non-Low Security Level, when a user attempts to change a parameter, when the user presses the Enter key to save the setting, the system will display the message “!Security Violation!”. The user must go back and enter their user ID and password. If the user enters an invalid password or no password the user is given read access only to all sub-menus.

**CAUTION**

Only personnel that have been properly trained should access the Medium and High-level security menus. Inadvertently changing a parameter can result in the machine shutting down or cause it not to function properly. These are factory default passwords. Taylor Products recommends that they should not be changed.

---

---

The manager controls access by only providing the high-level password to personnel that should have access to all of the menus. The manager should only provide the medium-level password to personnel that should have access to the menus that have their security level set to medium and low. For personnel that will only have access to menus with a security level of low do not need a password. If a menu has a security setting of Medium or High, if the user does not put a password in, or puts the wrong password in, they will still be able to access the menu, but their access will be read-only.

The T3000 control panel is typically used to configure security settings. Follow the steps below to set security.

1. Press the User shortcut key. Enter the User ID and high-level password.
2. From the Standby Display, press the Setup key. The CONFIGURATION MENU will appear.
3. Use the up/down arrow keys to position the cursor in front of SECURITY. Press the Enter key.
4. The SECURITY MENU will appear. The cursor will be in front of SET SECURITY MENU selection. Press the Enter key.
5. The SET SECURITY MENU will appear. The Top-Level Menus will be listed with the security level set at the default LOW setting.
6. Press the up/down arrow keys to position the cursor in front of the desired menu selection.
7. Press the left/right arrow keys to change the security setting for that menu item.
8. Once the desired security level is displayed, press the Enter key to set the entry.
9. If other menus require an adjustment to its security setting, repeat steps 5 through 7.
10. When all security setting adjustments have been completed, press the Exit key to return to the Standby Display.

## 3.7 Calibration

Each IBC-3000 is calibrated prior to leaving the factory. However, the unit should be reassessed before its first use. It is recommended that calibration of the unit should be checked every week or anytime that a new load cell is installed, or any other changes are made that affect the weigh system. A certified test weight must be used to check the calibration of the IBC-3000.

*Note: Make sure that the shipping brackets have been removed before beginning the calibration process.*

### 3.7.1 Calibrating the T4000 Control Panel

The information that follows provides calibration procedures for the T4000 Weigh Controller. Alternatives to any procedures implied or explicitly contained in this document are not recommended. In order for the Weigh Controller to work properly, it must be calibrated prior to operation. All calibration should be done in the Gross mode.

Additionally, Taylor Products recommends that a calibration schedule be developed and followed. This schedule will ensure that the machine's weighing mechanism and controller receives a thorough inspection on a regular basis, which should help reduce machine down time and increase overall productivity. It is recommended that the instrument be re-calibrated periodically or when not in use for extended periods of time. Be sure to follow all the procedures completely to insure that the weights read by the controller are accurate. It is very important that the user and service personnel be familiar with the procedures contained in this chapter before installing or operating the T4000 Weigh Controller.

Only those with proper access are allowed to calibrate the T4000. This means that a password must be entered to gain access to the calibration function. The password is factory set to 2205.

#### 3.7.1.1 Pre-Calibration, Mechanical Check Procedures

1. Check to determine if the load cells have been installed properly.
  - a. Refer to the operation and maintenance manual for the machine being worked on for proper installation instructions.
  - b. On some load cells there is an arrow that indicates the direction of the applied load. If the arrow is pointing in the wrong direction, change the position of the load cell so that it is mounted in the direction of the applied load.
2. Check for Binding on the load cell or other parts of the system.



#### **CAUTION**

Binding on a scale/vessel or load cell does not allow the load cell free vertical movement and may prevent the instrument from returning to the original zero reference point.

---

---

- a. The load cell must be mounted so that 100% of the load (vessel + contents) is applied vertically to the load cell.

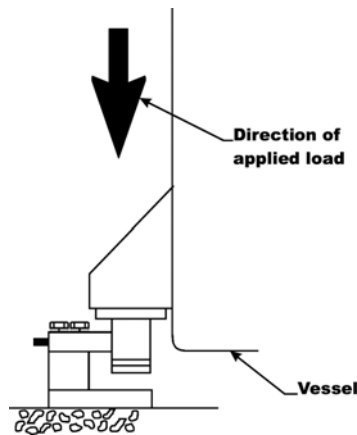

**Figure 3-9.** Load Passing Through Load Cell

- b. Do a visual check to see that nothing is binding the load cell or other parts of the weighing system. Make sure that nothing is draped over the scale/vessel or the load cell, such as a hose, electrical cord, tubes, or other objects.
3. Check to see that nothing comes in contact with the scale/vessel other than service wires and piping that have been properly mounted with flexible connectors.
4. Check to see that there is power to the T4000.
  - a. If there is power to the controller the front panel display should be illuminated.
  - b. If the display appears and a weight value is being displayed, the unit is ready for calibration.
5. Allow the instrument to warm up for about 15 minutes before doing the calibration procedures.
6. Put a load (weight) on the scale or vessel. For a full load test, the operator can put 80 – 100% of the expected weight for their process on the scale or vessel.
7. Check to see if the weight reading changes on the display in the proper direction.
  - a. For example, if the display reads 100 lbs and a 20 lb load is placed on the vessel or scale, the display should read 120 or some value over 100.
  - b. If the display reads 80 lbs and a 20 lb load is placed on the vessel or scaled, the reading is going in the wrong direction and indicates some problem with the system.
  - c. If the display is reading improperly or shows no change there is something wrong with the configuration or the load cells.
8. If the display changes in the proper direction, remove the weight and proceed to calibrate the Weigh Controller.

**Note:** When calibrating the T4000 for the first time, go from one sub-menu to the next in sequence.

**Note:** The settings provide below are just an example. The actual settings used will vary based on the specific application.

### 3.7.1.2 T4000 Calibration

1. Make sure the T4000 has been configured for the intended application. This includes setting the units, decimal point, scale capacity, averages, etc.
2. From the Summary display press the Enter key. The Configuration menu appears.
3. Press the down arrow button until the cursor is in front of Calibration.
4. Press the Enter key. The Calibration menu appears.
5. Traditional Calibration is the method of calibration that uses test weights. Taylor Products recommends that the test weights total 80 – 100% of the desired package weight, and that the weight be distributed uniformly on/in the scale.
6. From the Summary display, press the Enter key. The Configuration menu appears.
7. Press the down arrow button until the cursor is in front of the Calibration line.

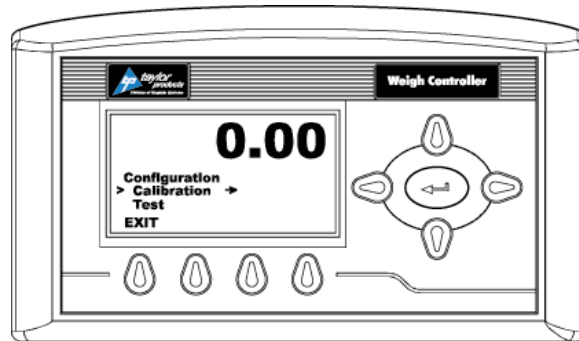

**Figure 3-10.** Placing the Cursor In Front Of Calibration

8. Press the Enter key. The Calibration menu appears.
9. Press the down arrow button until the cursor is in front of “Trad Cal”.

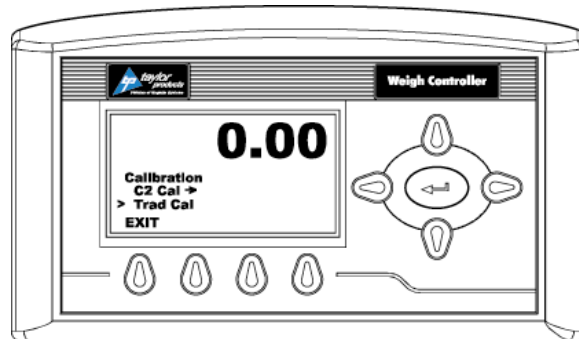

**Figure 3-11.** Placing The Cursor In Front Of Trad Cal

10. Press the Enter key. The Trad Cal menu appears.

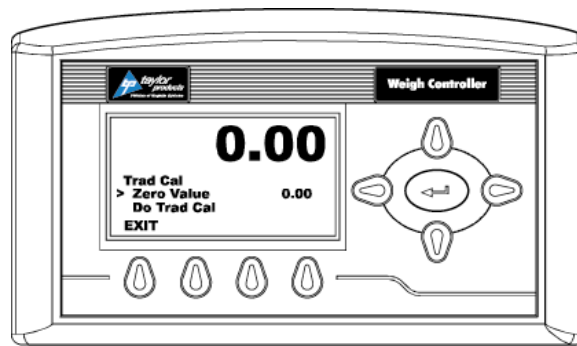

**Figure 3-12.** Placing The Cursor In Front Of Zero Value

11. Press the Enter key. The Zero Value weight menu appears.
12. Traditional Calibration requires a zero point and the physical placement of test weights on the scale. To set the Zero Value Weight:
  - a. Remove all weight “live load” from the Scale. The Zero Value should be 0.0.



**CAUTION** The scale **MUST** be empty.

- b. Wait 12 seconds or more.
13. Use the left and right arrow buttons to position the cursor. Use the up or down arrow buttons to enter the Zero Value for this instrument.

*Note: Most applications will set the Zero Value to 0.00.*

14. Press the Enter key to save the entry.
15. Press the down arrow button until the cursor is in front of “Do Trad Cal ” (Zero)”.
16. Press the Enter key to Do the Cal Trad Cal (Zero).
  - a. A “Cal Completed OK” message appears briefly if the calibration was successful.
  - b. An Error number appears if the calibration was not successful. An Error list is provided with the troubleshooting information later in this guide. Refer to this list in order to correct the error.
17. Press the down arrow button until the cursor is in front of Span Value.
18. Press the Enter key. The Span Weight menu appears. The last Span Weight is displayed.

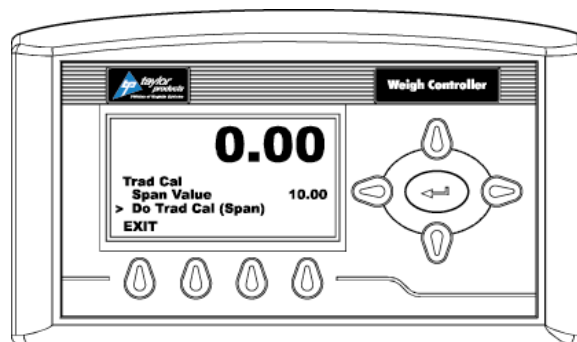
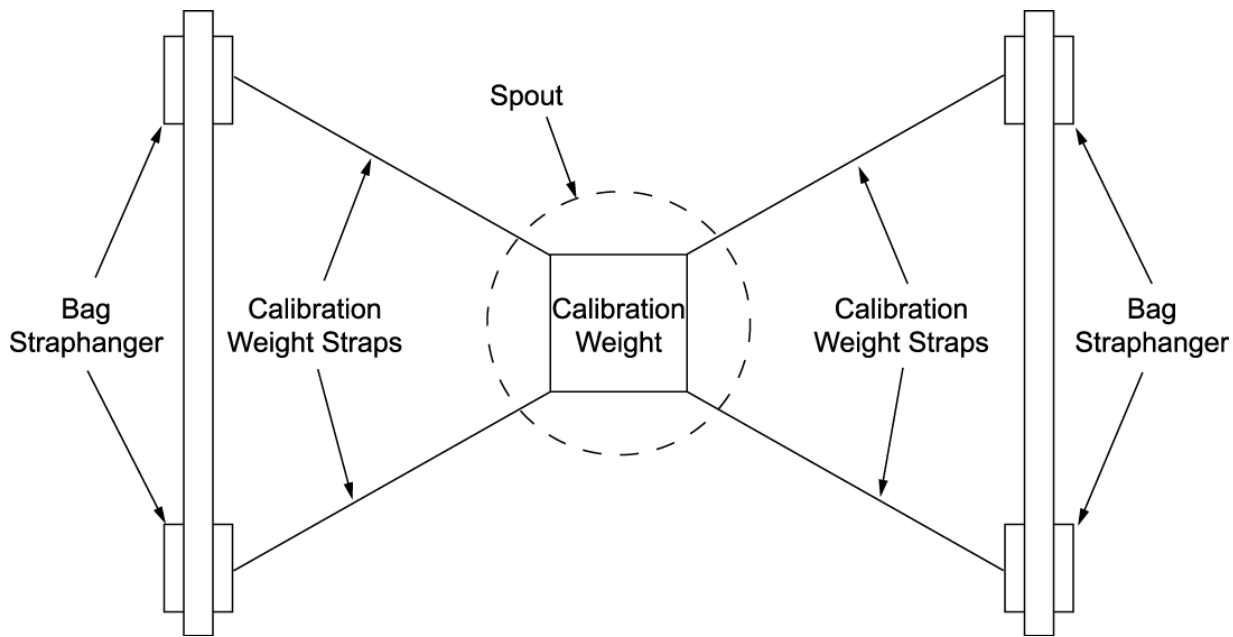

**Figure 3-13.** Span Value Displayed

## Setup/Installation

19. To set the Span Weight:
  - a. Place a certified test weight on the scale.
  - b. Use the left and right arrows to position the cursor and the up or down arrows to enter the value of the test weight. If a 10 lb. weight is used, enter 10.00.
  - c. Press the Enter key to save the entry.
20. Press the down arrow button until the cursor is in front of “Do Trad Cal (Span)”.
21. Press the Enter key to Do the Trad Cal (Span).
  - a. A “Cal Completed OK” message appears briefly if the calibration was successful.
  - b. An Error number appears if the calibration was not successful. An Error list is provided with the Troubleshooting information later in this guide. Refer to this list in order to correct the error.
22. The scale is now calibrated.

**Important:** If the machine is used to fill bulk bags (hung from the bag strap hangers), the calibration weight should be hung from the bag strap hangers so that it is centered under the spout. If the machine is used to fill drums, then the calibration weight should be placed so that it is centered on the weigh platform.



**Figure 3-14.** Hanging A Calibration Weight From The Bag Straphangers

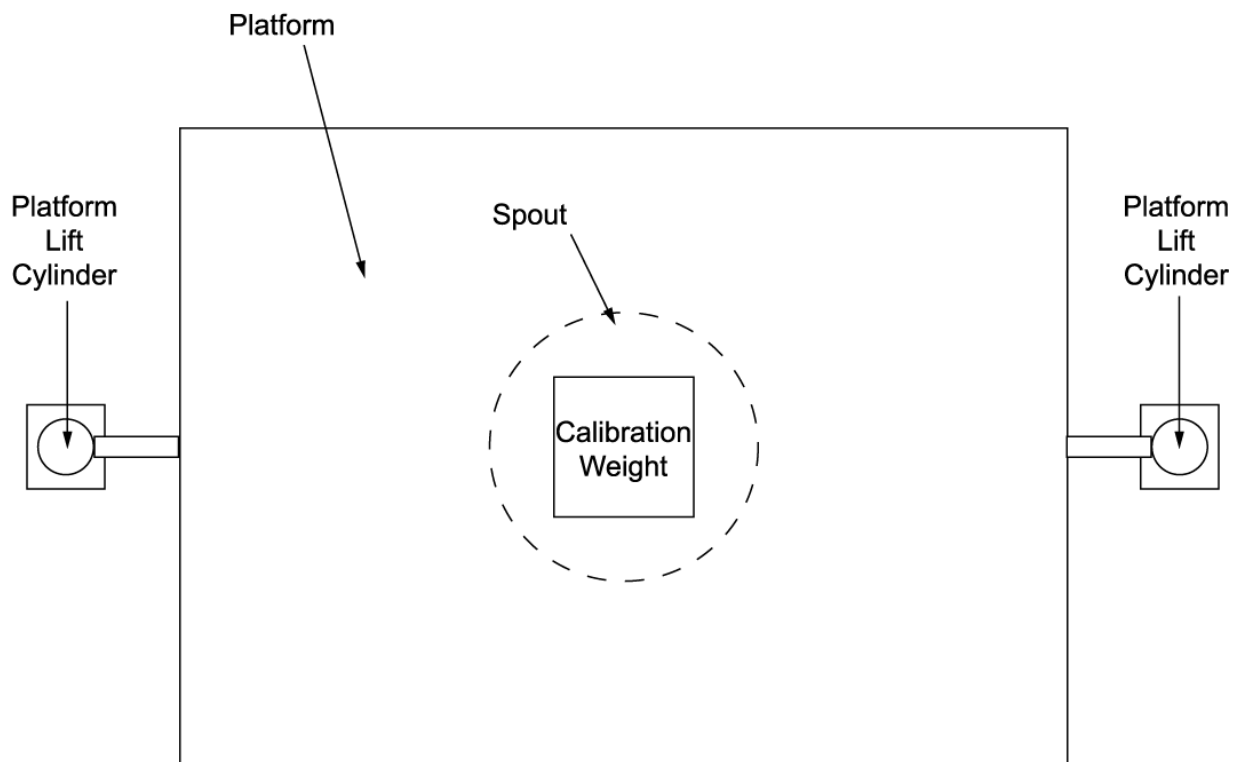

**Figure 3-15.** Placing A Calibration Weight On The Weigh Platform

### 3.7.2 Calibrating The Optional T3000 Control Panel

There are two methods for calibrating an IBC-3000 equipped with the T3000 control panel.

Before beginning the calibration procedure, be sure that the machine is ready to be calibrated. Make sure that the load points have been installed properly. Follow the steps below to make sure the IBC-3000 is ready for calibration:

1. Make sure the load system is free of binding and that nothing is draped over the equipment, such as hoses, electrical cords, tubes, etc.
2. Verify that the load cell is mounted so that 100% of the load always passes vertically through the load cells at the same point.
3. Check all communication and power cables are securely fastened to their connectors on the rear of the control panel.
4. Make sure that power is supplied to the controller. This is indicated by the panel display being illuminated.

Use the following steps to calibrate the T3000 control panel.

1. Turn the power switch on the control box to the ON position. Allow the control panel to warm up for thirty (30) minutes.
2. Press the User shortcut key. Enter the User ID and medium or high-level password.
3. Press the Setup key to access the CONFIGURATION MENU.
4. Use the up/down arrow buttons to scroll to the CALIBRATION line. Press the Enter key to access CALIBRATION.

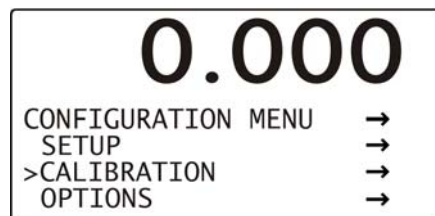

Figure 3-16. Calibration Line

5. Use the left/right arrow keys to toggle to the TRAD selection if it is not already displayed. Press the Enter key.

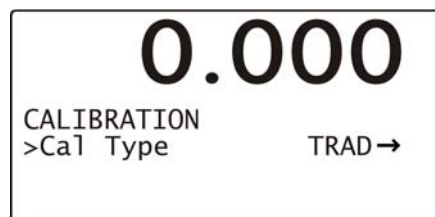
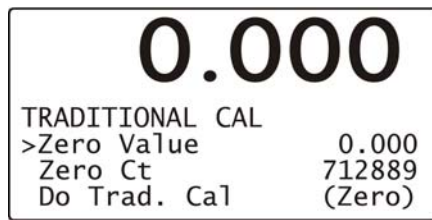

Figure 3-17. Selecting TRAD Calibration

6. A Function OK message will flash briefly in place of the Cal Type line, then the TRADITIONAL CAL screen will appear. Check the display to make sure that the Zero Value reads 0.0.



**Figure 3-18.** Checking Zero Value

7. Use the up/down arrow keys to scroll to the Do Trad. Cal (Zero). Press the Enter key. The weight display will display !Calibration in Progress! and will return to its calibration screen.
8. Use the up/down arrow keys to scroll to the Span Value selection and use the alphanumeric keypad to enter the weight that will be used for calibration. Press the Enter key.

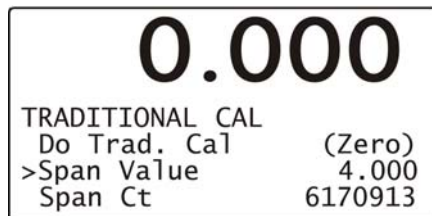

**Figure 3-19.** Setting Span Value

9. Use the up/down arrow keys to scroll down to the Do Trad. Cal (Span). Place the calibration weight on the scale by hanging it on the fill spout directly under the bag clamp cylinder. Press the Enter key. The weight display will display !Calibration in Progress! and will then return to its calibration screen. Press the Exit key three times to return to the main screen.

This Page Intentionally Left Blank

## Chapter 4 Operation

### 4.1 General Description

This chapter will provide detailed descriptions of the operational controls of the IBC-3000.

#### 4.1.1 Non-Weighing IBC-3000

On the standard IBC-3000, the operator manually controls the beginning and the end of the fill cycle. The machine does not weigh the container. The containers are filled until the product reaches a pre-determined level in the container, where the operator then manually stops the product flow.

#### 4.1.2 Weighing IBC-3000

On units that are designed to weigh, the weigh system is controlled via the control panel. The operator will use the control system to set SP1 (dribble weight), SP2 (cutoff weight), and the desired package weight (target weight).

Weighing IBC-3000 machines may be equipped with a T4000 control panel, or with an optional T3000 control panel. In either case, the operation of the IBC-3000 is very straightforward.

### 4.2 General Fill Cycle Information

A weighing IBC-3000 will be set up as a dual set point unit. This means that the machine will fill the package using two distinct fill rates, bulk rate and dribble rate. Bulk rate is a faster rate that is used to fill the package quickly until the package is nearly full. The bulk rate is set with the Fast A control. Once the package achieves the weight set with set point 1 (SP1), also known as the dribble weight, the fill rate will slow to the dribble rate that is set with the Slow A control. Once the package achieves the weight set with set point 2 (SP2), also known as the cutoff weight, the knife gate will close. Once the product that is in free fall settles into the package, the package weight should match the target weight.

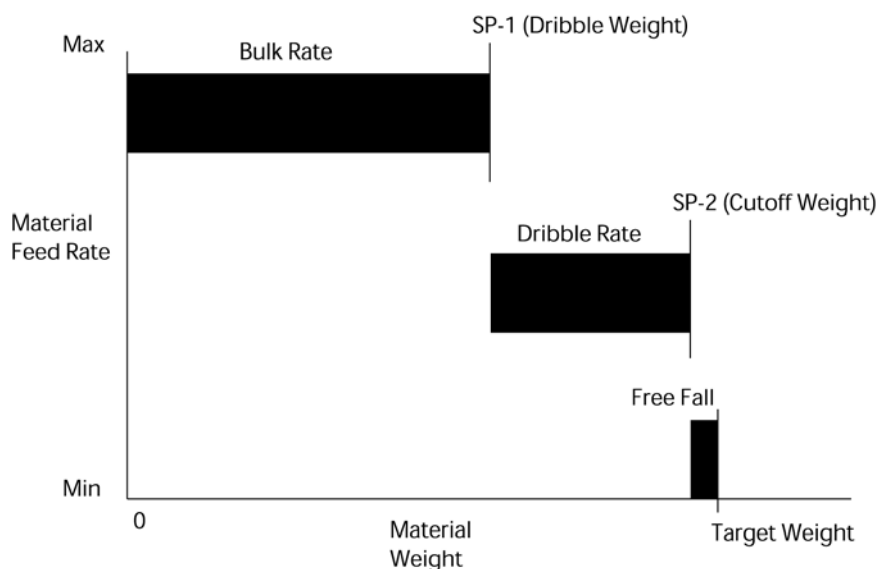

**Figure 4-1.** Bulk Rate vs. Dribble Rate

## 4.2.1 Typical Fill Cycle

The typical fill cycle for an IBC-3000 that has been configured to weigh will proceed as follows:

1. Install a new container and position it for filling.
2. As soon as IBC-3000 is turned on, the STOP button is pulled out, and the START button is pressed, the IBC-3000 will inflate the neck seal and will open the knife gate to start filling the container with material.

*Note: Once the START button has been pressed, the meter will tare the container before starting the fill cycle. Because of this, it is very important for the operator to make sure that they are not resting their hand on the container or lift/weigh platform.*

3. Once the weight of the container reaches the dribble weight (SP1), the knife gate will partially close and continue to fill the package at a reduced rate.
4. Once the weight of the container reaches cutoff weight (SP2), the knife gate will close completely and the inflatable neck seal will deflate.
5. Any product that is in freefall will settle into the package.
6. Release the bag straps by releasing the bag straphangers, or by using the optional BAG STRAP RELEASE button.
7. Lower the lift platform (if equipped) to lower the container for removal.

As soon as the container has been removed, a new container has been placed on the spout and the START button has been pressed, the neck seal will inflate and the knife gate will open to begin filling the container. This cycle will repeat until the hopper is empty, or until the unit is turned off or stopped.

### 4.3 Operational Controls

The IBC-3000 comes standard as a non-weighing machine, but may be ordered with one of two optional weighing systems. The operational controls will vary, based on the type of control unit and any custom features that have been selected. This manual will focus on machines equipped with a T4000 or the optional T3000 control panels.

#### 4.3.1 Control Box With T4000 Control Panel

The T4000 control panel uses an electronic display in conjunction with a control pad that allows the user to make system adjustments and to monitor the system status. The standard weighing configuration includes a T4000 control panel, in addition to the manual controls and indicators to allow the operator to operate the machine. The T4000 is a collaboration between Taylor Products and Hardy Instruments. The T4000 has the ability for total monitoring and instrument control. The T4000 features the following functions:

- LCD screen
- Directional arrow keys
- Enter key
- Function keys

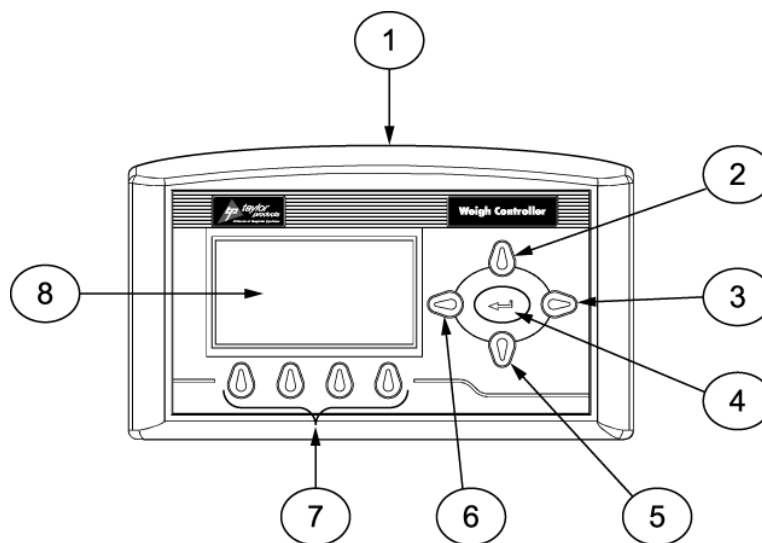

Item #	Description	Item #	Description
1	Control panel	5	Down arrow key
2	Up arrow key	6	Left arrow key
3	Enter key	7	Function keys
4	Right arrow key	8	LCD screen

Figure 4-2. T4000 Control Panel

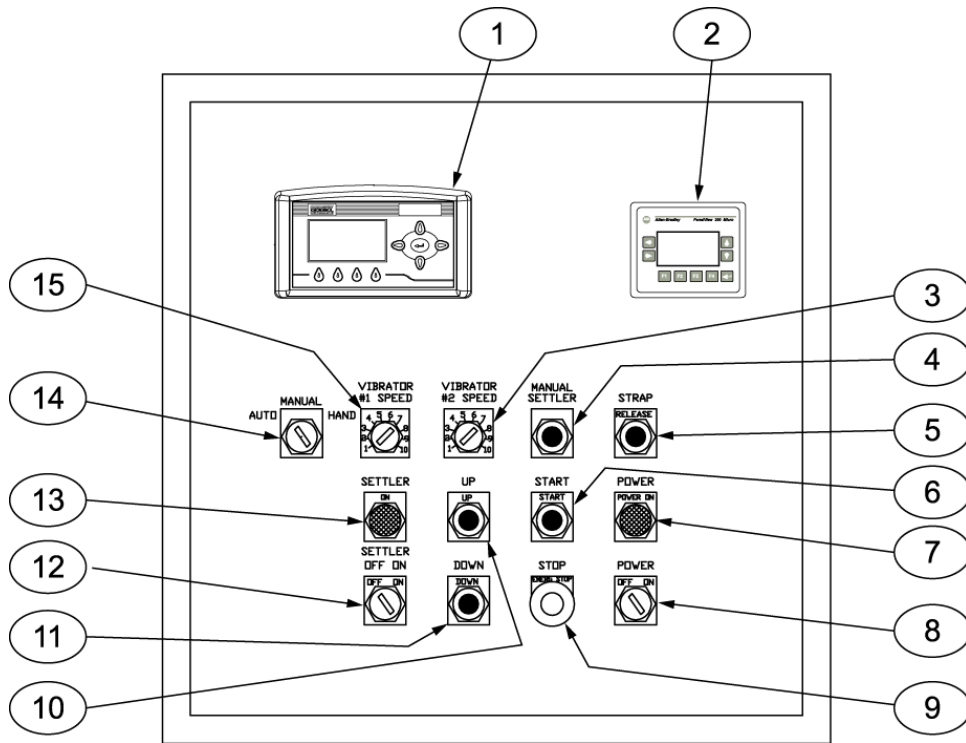

Item #	Description	Item #	Description
1	T4000 control panel	9	STOP button/indicator
2	PV300 control panel	10	UP button
3	VIBRATOR #2 speed control knob	11	DOWN button
4	MANUAL SETTLER button	12	SETTLER ON/OFF button
5	STRAP button	13	SETTLER ON indicator
6	START button	14	AUTO/MANUAL/HAND switch
7	POWER indicator	15	VIBRATOR #1 speed control knob
8	POWER switch		

Figure 4-3. Control Box with T4000 Control Panel

### 4.3.2 Control Box With T3000 Control Panel

The weighing IBC-3000 is available with an optional T3000 control panel. The T3000 is a control panel that has been jointly designed by Taylor Products and Hardy Instruments. The T3000 control panel uses an electronic display in conjunction with a control pad that allows the user to make system adjustments and to monitor the system status. The T3000 has the ability for total monitoring and instrument control. The T3000 features the following functions:

- Weight display
- Alphanumeric keypad
- Function keys
- Enter/Exit keys
- Arrow keys
- Infrared (IR) port (not used)

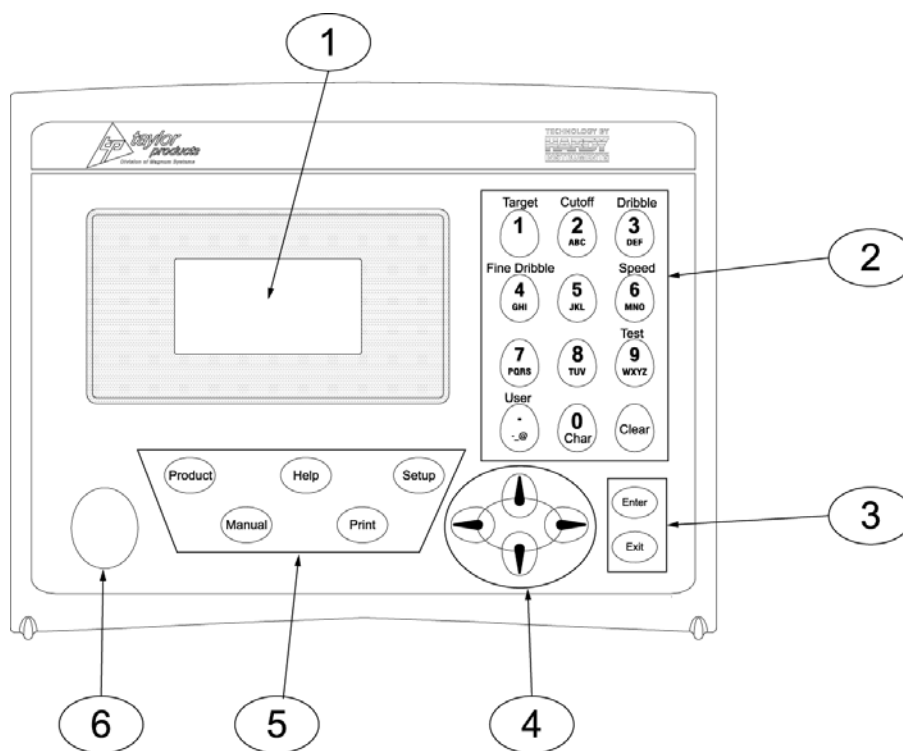

Item #	Description	Item #	Description
1	LCD screen	4	Directional arrow keys
2	Alpha-numeric keypad	5	Function keys
3	Enter and Exit keys	6	Infra Red port (not used)

Figure 4-4. T3000 Control Panel

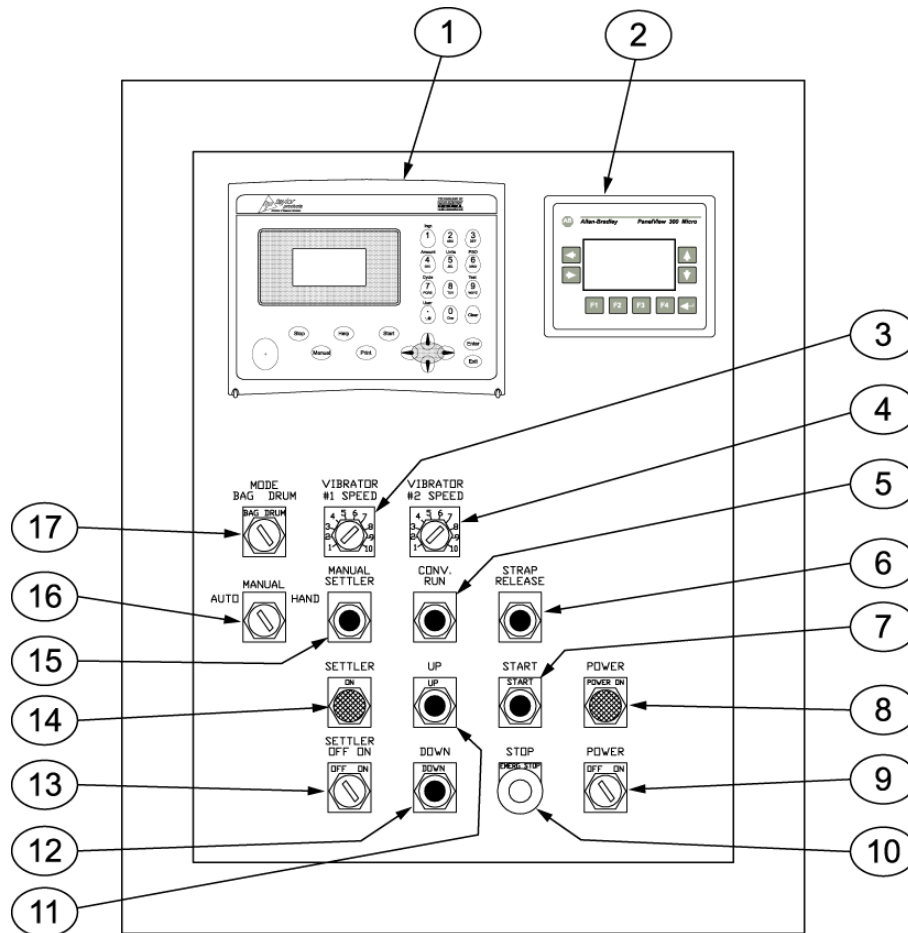

Item #	Description	Item #	Description
1	T3000 control panel	10	STOP button/indicator
2	PV300 control panel	11	UP button
3	VIBRATOR #1 SPEED control knob	12	DOWN button
4	VIBRATOR #2 SPEED control knob	13	SETTLER ON / OFF switch
5	CONV. RUN button	14	SETTLER ON indicator
6	STRAP RELEASE button	15	MANUAL SETTLE button
7	START button	16	MANUAL / AUTO / HAND switch
8	POWER ON indicator	17	MODE BAG / DRUM switch
9	POWER switch		

Figure 4-5. Control Box with T3000 Control Panel

### 4.3.3 PanelView (PV300) Controls

The IBC-3000 has several operational features that are controlled via logical timers that are programmed into the PLC. Access to the timers and adjustment of the timers is accomplished using the PV300 control panel.

#### 4.3.3.1 PV300 Menus

The PV300 has several menus that allow the operator to adjust different timer functions for optional equipment on the IBC-3000. The timer function descriptions listed below are described from the standpoint of the settler being turned off. The functions of the timer will be slightly different when the settler is turned on.

- **Platform Up “No Settler/Settler Off” (0-25 Sec)** – Platform up will start when the dribble set point is reached. The platform will rise for the programmed amount of time and then stop and hold that position. Platform up should move the bulk bag from nearly hanging completely from the bag straps to a position where the bag bottom is flattened, allowing the bag to fill completely and evenly.
- **Platform Up “Settler On” (0-25 Sec)** – Platform up will start after the Auto Zero is complete or after the Start Lift Time on machines without Auto Zero. The platform will rise for the programmed amount of time and then stop and hold that position. Platform up should move the bulk bag from nearly hanging completely from the bag straps to a position where the bag bottom is flattened, allowing the bag to fill completely and evenly.
- **Platform Down “Settler Off”(0-25 Sec)** – This timer is not used, unless the IBC-3000 is equipped with the settler option and that option is turned on.
- **Platform Down “Settler On”(0-25 Sec)** – This timer is activated when the dribble (SP1) is reached. The platform will then travel down until the timer expires.

***Important:** Be careful not to allow the platform to travel down far enough to make the down proximity switch, this could cause a filling error. The platform should also be done moving before SP2 is reached, if it is not platform motion could cause inaccurate weights. If SP1 is set too close to SP2 the down motion of the filling bag could cause the SP2 to make and create an under filled container.*

- **Start Lift Time (0-25 Sec)** – When the start button is pressed, the platform will find the down proximity switch. The platform will then rise for the programmed amount of time. That time setting is called the Start Lift Time. The purpose of the timer is to get the bag into the ideal filling position. This timer can be varied as bag sizes or types change. At the end of this timer the IBC will activate the Auto Zero Delay or, on machines without Auto Zero, open the knife gate to start the fill.
- **Auto Zero Delay (0-25 Sec)** – After the Start Lift Timer expires, the IBC-3000 will pause for the programmed amount of time. The purpose of this timer is to allow time for the platform to stop moving, so the scale can auto zero. Once the Auto Zero is complete the knife gate opens.
- **Inflator Time (0-25 Sec)** – This timer starts after the Zero is complete. The diverter for the bag inflator will activate causing the bag to inflate for the programmed amount of time. The bag inflator is sometimes needed to ensure a good bag shape for proper filling. The bag inflator is an optional device and may not be installed on all IBC-3000 machines.

## Operation



When equipped with the pallet dispenser option, additional timer functions are available. They are:

- **Fingers Out, Down Delay (0-10 sec)** – When the pallet dispenser up limit (located on the scissor lift) switch is made the dispenser fingers start retracting and this timer starts. The purpose of this timer is to allow time for the fingers to clear the pallet stack.
- **Dispenser Down Timer (0-10 sec)** – When the pallet dispenser down limit (located on the scissor lift) switch is made this timer starts. The purpose of the timer is to allow the full weight of the pallet to rest on the drag chain conveyor before it starts.

The following pages provide some examples of possible menu screens. The menu screens used on individual machines and the order that they appear in may vary, based on options that are ordered. The manual does not show all available menu screens, as some customers may order custom menus.

The PV300 menus are controlled by the operator using the F-keys and the up/down arrow keys. The tables below will illustrate the menus and describe the function of each applicable keystroke.

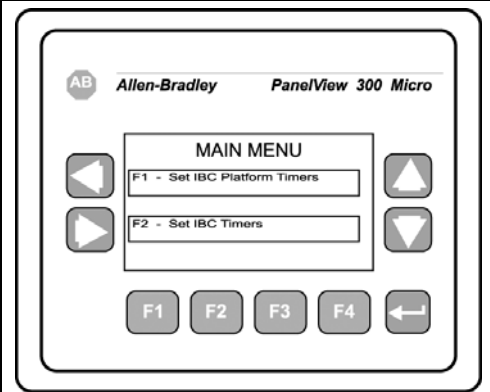
**Table 4-1.** PV300 Main Menu

	<b>Key</b>	<b>Function</b>
		Pressing the F1 key will access the IBC Platform Timers menu.
		Pressing the F2 key will access the IBC Timers menu.

**Table 4-2.** PV300 Timer 1 Menu

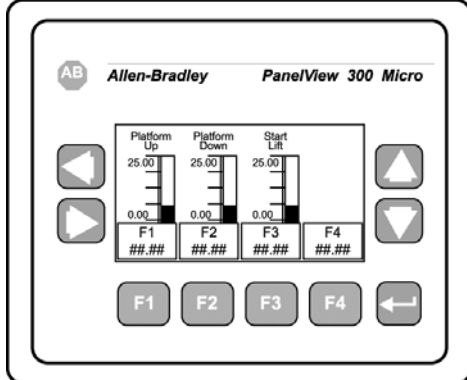
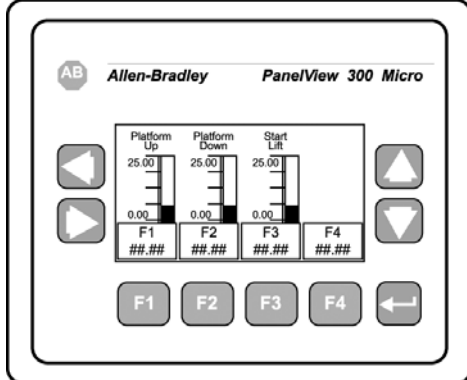
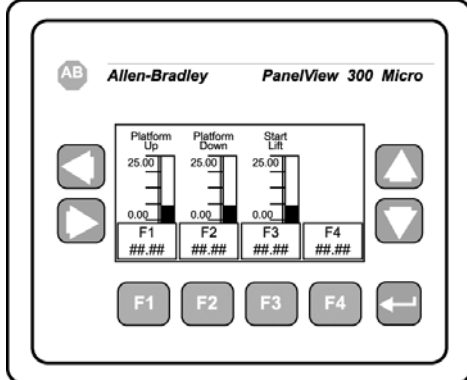
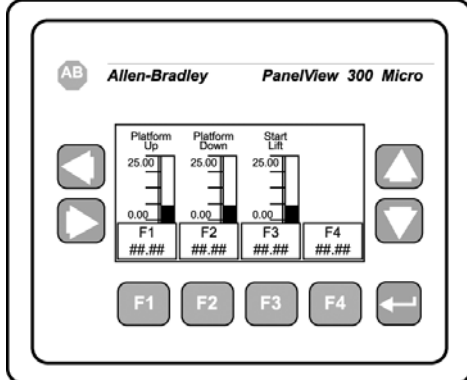
Key	Function
	Pressing F1 allows the operator to adjust the Platform Up setting.
	Pressing F2 allows the operator to adjust the Platform Down setting.
	Pressing F3 allows the operator to adjust the Start Lift setting.
	Function differs, based on configuration.

**Table 4-3.** PV300 Dispenser Menu

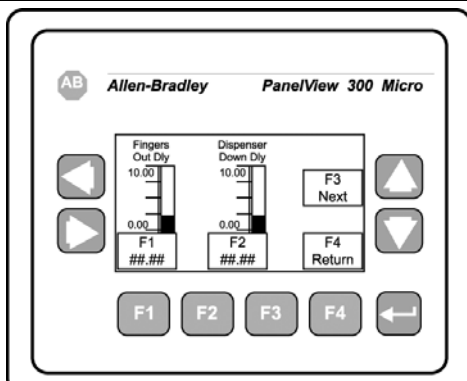
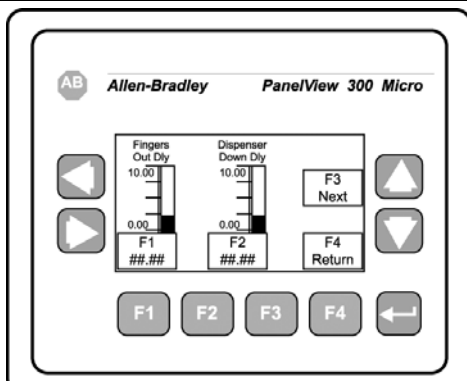
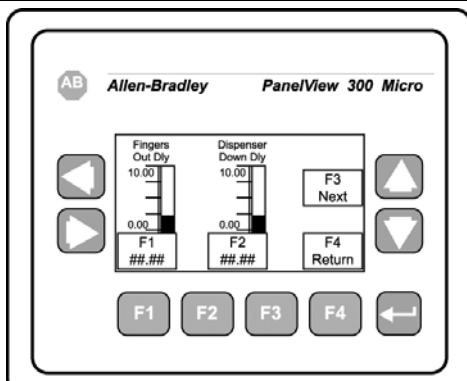
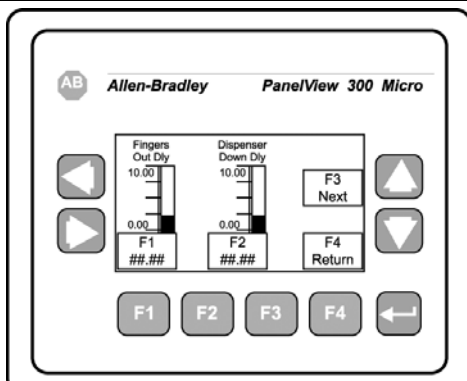
Key	Function
	Pressing F1 will allow the operator to adjust the Fingers Out Delay setting.
	Pressing F2 will allow the operator to adjust the Dispenser Down Delay setting.
	Pressing F3 will take the operator to the next menu in the sequence.
	Pressing F4 will return the operator to the previous screen.

**Table 4-4.** PV300 Dispenser 2 Menu

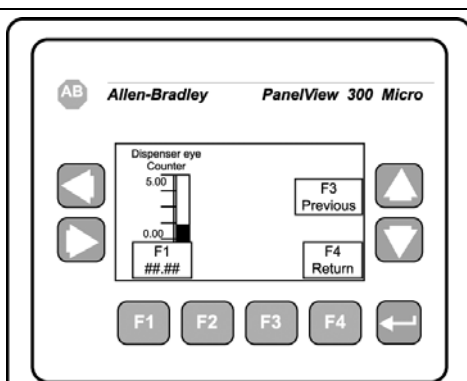
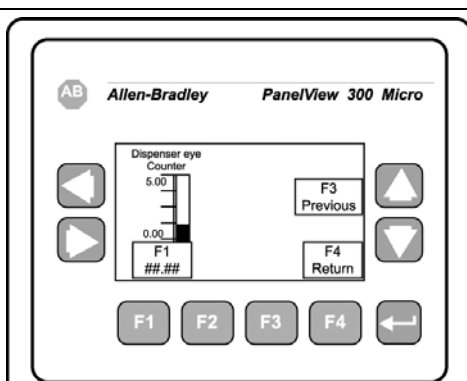
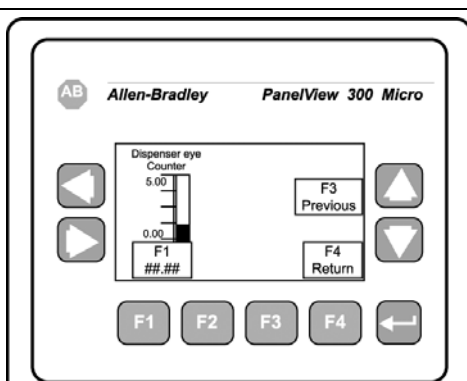
Key	Function
	Pressing F1 will allow the operator to adjust the setting for the dispenser eye counter.
	Pressing F3 will take the operator to the next menu in the sequence.
	Pressing F4 will return the operator to the previous screen.

**Table 4-5.** PV300 Conveyors Menu

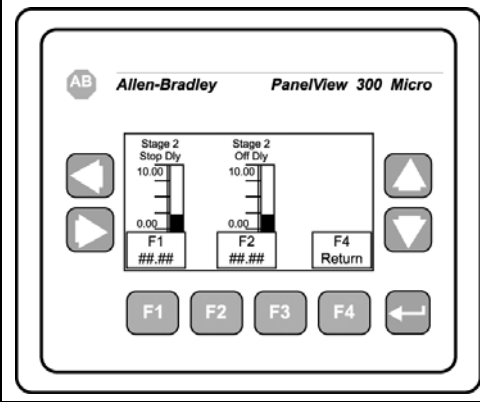
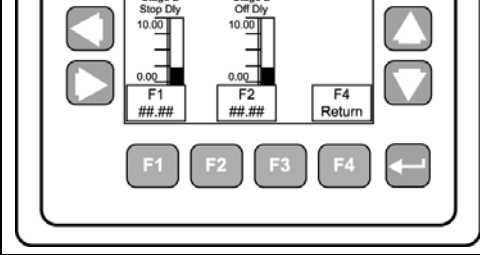
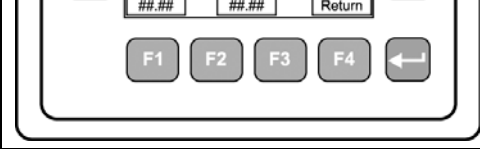
Key	Function
	Pressing F1 will allow the operator to adjust the Stage 2 Stop Delay function.
	Pressing F2 will allow the operator to adjust the Stage 2 Off Delay function.
	Pressing F4 will return the operator to the previous screen.

**Table 4-6.** PV300 Timer 2 Menu

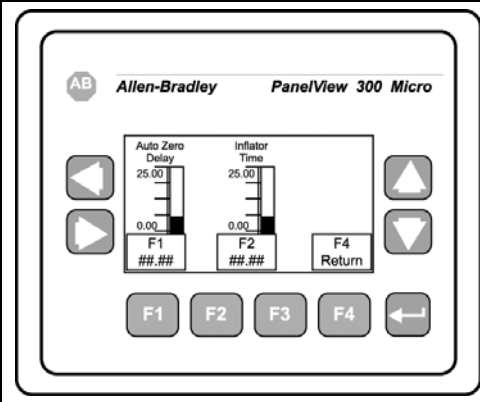
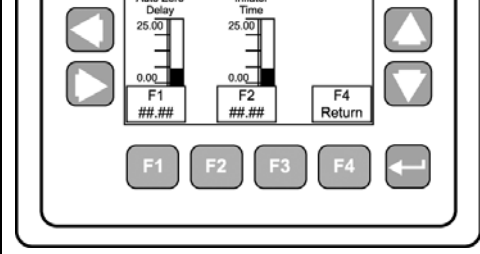
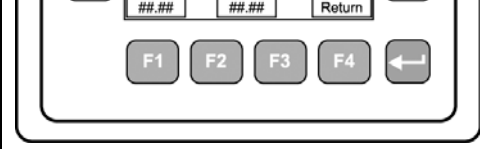
Key	Function
	Pressing F1 will allow the operator to adjust the setting for the Auto Zero Delay.
	Pressing F2 will allow the operator to adjust the Inflator Time setting.
	Pressing F4 will return the operator to the previous screen.

## 4.4 Initial Setup

IBC-3000 units can be categorized based on their control type, as follows:

- Non-Weighing
- Weighing
  - T4000 Controls
    - Dual set point
  - T3000 Controls
    - Dual set point

The setup procedures vary based on the type of IBC-3000.

### 4.4.1 Setting Up A Non-Weighing IBC-3000

Non-weighing IBC-3000 units do not require any special setup procedures.

### 4.4.2 Setting Up A Weighing IBC-3000 With A T4000 Control Panel

Use the procedures below to perform the initial setup on IBC-3000 units with a T4000 control panel.

Before the IBC-3000 is put into operation, the initial setup procedure needs to be performed to ensure proper weighments. Use the following procedure to set up the IBC-3000 for its first run. Before beginning this process, the operator should become familiar with the controls and functions of the IBC-3000.

1. Turn the POWER switch to the ON position. Allow thirty (30) minutes for the controls to warm up.

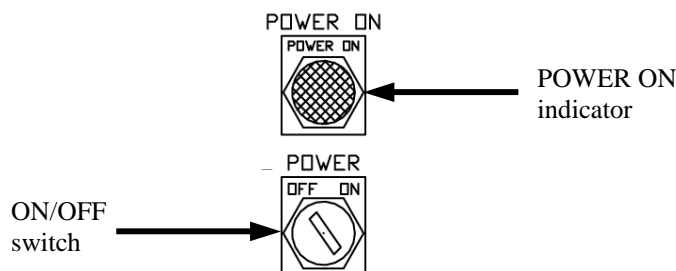

**Figure 4-6.** IBC-3000 ON/OFF Switch

2. Set SP1 and SP2.
  - a. Press the function key below SP1. Use the directional arrows to set the dribble weight, approximately 90% of the target weight. Press the function key below EXIT.
  - b. Press the function key below SP2. Use the directional arrows to set the cutoff weight. Press the function key below EXIT.

**Note:** Due to the weight of the product in free fall, the cutoff weight is typically set 1 to 30 lbs below the target weight. How far below the target weight will depend on the bulk density of the product.

## Operation

3. Press the START button. The IBC-3000 will begin filling the container with material at the bulk rate. After the dribble weight (SP1) has been reached, the knife gate will close partially. The IBC-3000 will continue filling the container at the dribble rate until the cutoff weight (SP2) has been reached. At this point the knife gate will close. **BEFORE** removing the container, check the weight display to see how close the actual container weight is to the target weight. If the actual container weight is more than or less than the target weight go back and adjust the SP2 setting up or down by an amount equal to the difference between the target weight and actual weight.
4. Remove the container.
5. Install a new container on the bag straphangers. Pressing the START button will cause the IBC-3000 to start the fill cycle. After the target weight has been reached, and the knife gate closes, check the weight display to make sure that actual weight matches the target weight. If the actual weight is on target, remove the container and install a new container on the spout. There will be a short delay before the knife gate opens and begins filling the new container. It is important to make any target weight correction before the container is removed. It may take several cycles before to get the machine properly set up for that specific product.

### 4.4.3 Setting Up A Weighing IBC-3000 With A T3000 Control Panel (Optional)

An IBC-3000 with the T3000 will be configured as a dual set point unit. This means that the machine will utilize two fill rates. The bulk rate is used to fill the container most of the way. When the package is approximately 90% full, the knife gate will close partially to reduce the amount of product that can flow through it. This is known as the dribble rate. The Pre-Fill procedure for a T3000 equipped unit is listed below:

1. Position the first container for filling.
2. Press the User shortcut key. Enter the User ID and medium or high-level password.
3. Press the Product key.
4. Use the up/down arrow keys to scroll through the list of 25 available products. Place the cursor next to the desired product name.
5. Press the Enter key.

6. Use the up/down arrow keys to scroll through the available parameters and position the cursor next to the parameter that needs adjusted. Each parameter, and its description, is listed below.
  - a. Accept Settings – Used to accept the current product settings
  - b. Target Wt – Used to set the desired final package weight
  - c. Target Window (wt)
    - i. Target Max – Used to set the upper tolerance of package weight
    - ii. Target Min – Used to set the lower tolerance of package weight
  - d. Cutoff Wt – Used to set the point where the filler will shut off.
  - e. Dribble Wt (on dual set point units) – Used to set the point where the controller will switch from bulk feed rate to the dribble feed rate.
  - f. Fast A (on dual set point units) – Used to set the bulk feed rate during the bulk stage.
  - g. Slow A – Used to set the bulk feed rate during the dribble stage.
  - h. UserVar1 – User defined variable 1
  - i. UserVar2 – User defined variable 2
  - j. UserVar3 – User defined variable 3
  - k. UserVar4 – User defined variable 4
7. Key in the new parameter and press the Enter key.
8. The “Entry Accepted” message will flash in the line for that parameter. When all changes have been made, use the up/down arrows to navigate back to the Accept Settings line.
9. Press the Enter key.
10. The Standby Menu should reappear with the new product listed.

**Note:** The Product Menu does not allow the operator to configure all of the parameters for each product. The operator must use the Adjust Product function from the Setup Menu.

**Important:** Once the T3000 is configured and ready for operation, the operator can toggle between Gross Weigh mode and Net Weigh mode by pressing the Enter key from the Standby Menu.

## 4.5 Operational Modes

The IBC-3000 utilizes three operation modes to allow for maximum flexibility. The three modes are:

- AUTO
- MANUAL
- HAND

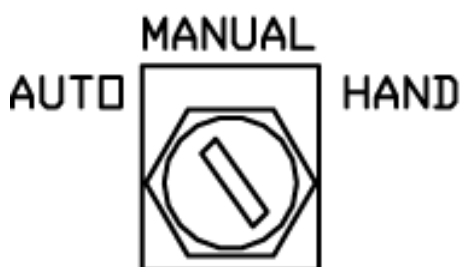

**Figure 4-7.** Mode Switch (Shown In AUTO Mode)

Operating the IBC-3000 using the three modes will be described on the following pages.

## 4.5.1 AUTO Mode

The AUTO mode operation will vary slightly, based on the usage of the optional settler.

### 4.5.1.1 Settler OFF, or No Settler

For machines that do not have the optional settler, or have the settler turned off, the AUTO mode will operate as follows:

1. Place the container for filling.
2. Press the START button.
3. The platform will start to lower and will continue until the down proximity switch is made.
4. The platform will stop.
5. The platform will start to rise and will continue for the amount of time programmed in the “Start Lift Time” setting.
6. The platform will stop.
7. The machine will pause for the amount of time programmed in the “Auto Zero Delay” setting.
8. The Auto Zero function will zero the scale.
9. The knife gate will open fully, allowing the product to fill the bag.
10. The package will continue to fill at the bulk rate until Set Point 1 (dribble weight) is reached.
11. The knife gate will partially close to the Dribble position.
12. The platform will start to rise and will continue for the amount of time programmed in the “Platform Up” setting.
13. The platform will stop.
14. The package will continue to fill at the dribble rate until Set Point 2 (cutoff weight) is reached.
15. The knife gate will close completely to stop the flow of product into the container.
16. The platform will start to rise and will continue until it reaches the height of the pin setting.
17. The operator can now release the bag straps and neck seal.
18. The operator can press the DOWN button to lower the platform to the down proximity switch position.

### 4.5.1.2 Settler On

For machines that have the optional settler turned on, the AUTO mode will operate as follows:

1. Place the container for filling.
2. Press the START button.
3. The platform will start to lower and will continue until the down proximity switch is made.
4. The platform will start to rise and will continue for the amount of time programmed in the “Start Lift Time” setting.
5. The platform will stop.
6. The machine will pause for the amount of time programmed in the “Auto Zero Delay” setting.
7. The Auto Zero function will zero the scale.
8. The knife gate will open fully to allow the product to fill the bag.
9. The platform will start to rise and will continue for the amount of time programmed in the “Platform Up” setting.
10. The platform will stop.
11. The settler will turn on and platform will begin to vibrate.
12. The container will fill until the container weight reaches Set Point 1 (dribble weight).

13. The knife gate will partially close to the Dribble position.
14. The settler will be turned off and the vibration will stop.
15. The platform will start to lower and will continue until the “Platform Down” timer expires.
16. The platform will stop.
17. The container will continue to fill at the dribble rate until Set Point 2 (cutoff weight) is reached.
18. The knife gate will close completely to stop the flow of product into the container.
19. The platform will start to rise and will continue until it reaches the height of the pin setting.
20. The operator can now release the bag straps and neck seal.
21. The operator can press the DOWN button to lower the platform to the down proximity switch position.

## 4.5.2 MANUAL Mode

The process is the same as AUTO except there is no Auto-Zero function.

### 4.5.2.1 Settler OFF or No Settler

For machines that do not have the optional settler, or do have the settler, but the settler is turned off, the MANUAL mode will operate as follows:

1. Place the container for filling.
2. Press the START button.
3. The platform starts to lower and will continue until the down proximity switch is made.
4. The platform will start to rise and will continue for the amount of time programmed in the “Start Lift Time” setting.
5. The platform will stop.
6. The machine will pause for the amount of time programmed in the “Auto Zero Delay” time setting.

*Note: This pause will occur even if Auto Zero is not active. For situations where Auto Zero is not being used, set this parameter to .01 for a faster fill.*

7. The knife gate will open fully to allow the product to fill the bag.
8. The container will fill until the container weight reaches Set Point 1 (dribble weight).
9. The knife gate will partially close to the Dribble position.
10. The platform will start to rise and will continue for the amount of time programmed in the “Platform Up” setting.
11. The platform will stop.
12. The container will continue to fill at the dribble rate until Set Point 2 (cutoff weight) is reached.
13. The knife gate will close completely to stop the flow of product into the container.
14. The platform will start to rise and will continue until it reaches the height of the pin setting.
15. The operator can now release the bag straps and neck seal.
16. The operator can press the DOWN button to lower the platform to the down proximity switch position.

### 4.5.2.2 Settler On

For machines that have the optional settler turned on, the MANUAL mode will operate as follows:

1. Place the container for filling.
2. Press the START button.
3. The platform is lowered until the down proximity switch is made.
4. The platform will start to rise and will continue for the amount of time programmed in the “Start Lift Time” setting.
5. The platform will stop.
6. The machine will pause for the amount of time programmed in the “Auto Zero Delay” setting.

*Note: This pause will occur even if Auto Zero is not active. For situations where Auto Zero is not being used, set this parameter to .01 for a faster fill.*

7. The knife gate will open fully to allow the product to fill the bag.
8. The platform will start to rise and will continue for the amount of time programmed in the “Platform Up” setting.
9. The platform will stop.
10. The settler is turned on and vibration starts.
11. The container will fill until the container weight reaches Set Point 1 (dribble weight).
12. The knife gate will partially close to the Dribble position.
13. The settler will be turned off and the vibration will stop.
14. The platform will start to lower and will continue until the “Platform Down” timer expires.
15. The platform will stop.
16. The container will continue to fill at the dribble rate until Set Point 2 (cutoff weight) is reached.
17. The knife gate will close completely to stop the flow of product into the container.
18. The platform will start to rise and will continue to the height of the pin setting.
19. The operator can now release the bag straps and neck seal.
20. The operator presses the DOWN button to lower the platform to the down proximity switch position.

### 4.5.3 HAND Mode

When operating in HAND mode, the only functions that operate automatically are set points and knife gate. The operational sequence will proceed as follows when in HAND mode:

1. Place the container for filling.
2. Press the START button.
3. The knife gate will open fully to allow the product to fill the bag.
4. The container will fill until the container weight reaches Set Point 1 (dribble weight).
5. The knife gate will partially close to the Dribble position.
6. The container will continue to fill at the dribble rate until Set Point 2 (cutoff weight) is reached.
7. The knife gate will close completely to stop the flow of product into the container.
8. The operator can now release the bag straps and neck seal.

During the fill cycle when in HAND mode, functions such as platform up/down, vibration, and zeroing can only be controlled manually, using the buttons and switches on the control panel.

## 4.6 Starting the Unit

Once the unit has been installed, and calibrated, the following steps must be completed before starting the unit:

1. Position a container for filling.
2. Verify that there are no loose objects on the machine or leaning on the machine.
3. Connect the machine to the power source.
4. Turn the Power Switch to the ON position.
5. Connect the main air supply. Check operating pressure and adjust as necessary. Refer to 1.5 Pneumatic Requirements for air pressure specifications.
6. Press the START button.
7. In the event of an error, or component failure, press the STOP button. If the error or failure cannot be resolved through the use of this manual, contact Taylor Products Technical Assistance at (800) 748-7000.
8. The inflatable neck seal should inflate and the knife gate should open to begin the fill cycle.

This Page Intentionally Left Blank

## Chapter 5

# Preventive Maintenance

### 5.1 General Description

To minimize downtime, preventive maintenance should be made a priority. Proper preventive maintenance practices will also extend the life of the equipment. Developing a preventive maintenance schedule will ensure that critical maintenance procedures are not missed.

### 5.2 Daily Maintenance Procedures

At the start of each working day, the following maintenance tasks should be performed before starting the machine:

1. Thoroughly clean the machine.
2. Check all fasteners.
3. Drain any water that may have accumulated in the water separator in the air supply line.

#### 5.2.1 Cleaning

Keeping the IBC-3000 clean is an important part of the daily maintenance tasks. Remove any dust and/or dirt that may accumulate on a daily basis. Keeping the unit clean will keep debris from entering the control mechanisms, which could cause the performance of the IBC-3000 to suffer. Also, by taking the time to clean the IBC-3000 on a daily basis, the operator will be able to give the IBC-3000 a thorough inspection. Take the time to inspect all wiring, air supply lines and connections, and components for possible damage.

#### 5.2.2 Check All Fasteners

The operator should check all fasteners on the IBC-3000 on a daily basis. Loose fasteners can cause unwanted vibration and wear.

### 5.2.3 Drain Water From the Water Separator

It is very important to remove unwanted moisture from the incoming air to ensure proper operating of the pneumatic components. At the beginning of each day, the operator should empty the water from the water separator. Follow the process below to drain the water.

1. Disconnect the air supply line.
2. Place a container under the drain valve.
3. There are two types of drain valves, follow the appropriate step below to open and close the drain valve:
  - a. If the water separator has a pin-type drain valve, press the pin upward and hold it in to drain the water. Release the pin once all water has drained.
  - b. If the water separator has a screw-type drain valve, turn the screw cap counter-clockwise to completely loosen the cap. After the water has completely drained, lightly push the cap upward to engage the threads and turn the cap clockwise until snug.
4. Discard the water from the container.
5. Reconnect the air supply line.

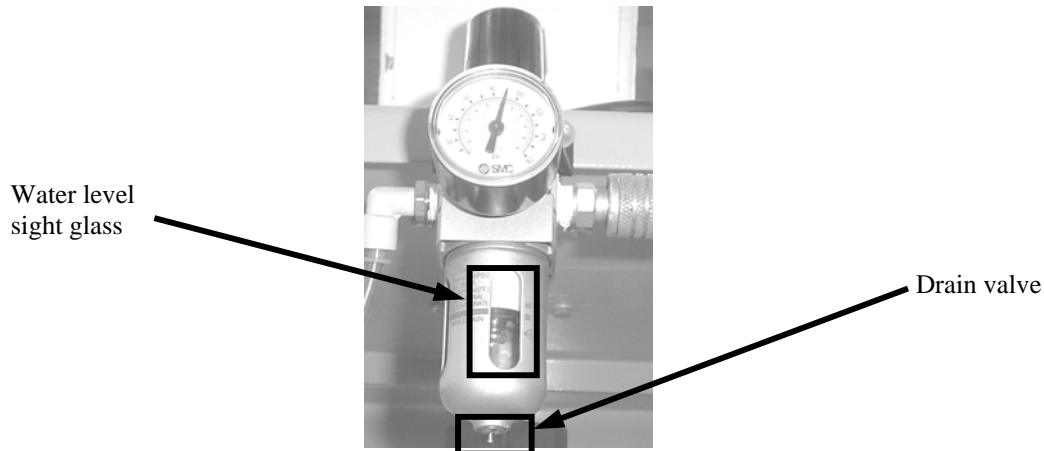

Figure 5-1. Air Supply Line Water Separator

### 5.3 Monthly Maintenance

On a monthly basis, perform the following maintenance tasks:

1. Recalibrate the IBC-3000. Refer to 3.7 Calibration.
2. Check the proximity switch mount to make sure it is tight. Tighten if necessary.
3. Check the stabilizer linkage to verify that they are loose.

### 5.4 Purge Kit Maintenance

For Purge Kit maintenance information, refer to System Maintenance in the Model 1001 A, Type or Z, Pressurization/Purging System Installation & Operation Manual in Appendix G of this manual.

## Chapter 6

# Troubleshooting

### 6.1 General Description

When a problem occurs, proper troubleshooting techniques will allow maintenance personnel to quickly identify the problem.

### 6.2 The Troubleshooting Process

The actual troubleshooting process is just as important as the repair process. Use the following troubleshooting keys to assist with the troubleshooting process:

- Identify the trouble symptom
  - What is the problem?
  - What were the circumstances when the problem occurred?
  - Could weather be a factor?
  - Are there any other contributing factors?
- Sectionalize the problem
  - Look at the problem.
  - What area of the machine is the problem occurring in?
  - Has anything changed recently?
- Isolate the problem
  - Try simple things first.
  - Observe indication and trouble codes.
  - Check test points.
  - Avoid complicating the problem.

### 6.3 Trouble Symptoms

Use the following information to assist in troubleshooting.

#### 6.3.1 Machine Will Not Power On

The IBC-3000 will not power on when the POWER switch is moved from the OFF to ON position. Follow the steps below to determine the cause.

1. Check for the presence of 110 VAC to the machine from the source.
2. Check the main fuse inside the cabinet to see if it has blown and needs replaced. Replace the fuse with one of the same type and rating as outlined in the electrical schematics of the machine.
3. Check to for 110 VAC to the switch on one side or the other when it is turned off.
4. Check the switch to make sure the current is able to pass through the switch when it is switched on. If it does not, replace the contacts.

### **6.3.2 Machine Will Not Start When the Start Button is Pressed**

If the machine will not begin the fill cycle when the start button is pressed, even though the power is turned on, and the STOP button has been pulled out, use the table below to troubleshoot the problem.

1. Check the LEDs on the PLC. The green power light and a green run light should be illuminated. If a fault LED is illuminated, refer to 6.5 PLC Error Messages.
2. For machines with an inflate button, make sure the button has been pushed. The IBC-3000 will not start if the button has not been pushed.
3. Push the STOP button in. Turn the AUTO/MANUAL switch to HAND. Pull the STOP button out. Switch the AUTO/MANUAL switch to AUTO. Push the inflate button to see if the machine will start.
4. Check the function of the platform proximity switch. It is located on one of the cylinders. It is a magnetic switch it senses a magnet inside of the cylinder. The switch is wired to an input on the PLC. When the platform is moved up and down, the input LED should illuminate. If it does not, the proximity switch may need to be replaced or adjusted.

### **6.3.3 Inflatable Neck Seal Will Not Inflate**

If the inflatable neck seal does not inflate when the start button is pressed, use the table below to troubleshoot the problem.

1. Check the gum rubber seal for holes or tears. Replace if needed.
2. Check for compressed air to the seal by removing the air supply line from the quick connect fitting. If air is not present, correct the air supply issue.
3. If the machine has a manual inflate option, a palm valve will be installed on the machine. Check for compressed air at the valve inlet. If compressed air is present at the inlet, check for compressed air at the outlet. If compressed air is not present at the inlet, correct the air supply problem. If compressed air is not present at the outlet, but is present at the inlet, replace the palm valve.
4. Check the neck seal pressure regulator, located on the leg of the machine, for proper operation. Adjust the air pressure as required. The air pressure is usually set around 5 psi.
5. If the machine is equipped with an automatically inflated seal, the machine will have some push buttons to inflate and deflate the neck seal. Check the operation of the inflate button by pressing the button and checking the LED input at the PLC to see if it illuminates. If it does not, check for 110 VAC at the button input contacts. If voltage is not present, correct power supply issue. If voltage is present, press the button and check for 110 VAC on the output contacts. If voltage is not present, replace the contacts.
6. Check the MAC valve on top of machine for proper operation. The valve is driven by an output from the PLC. When energized it opens the valve to inflate seal. If the PLC output is energized, 110 VAC should be present at the coil of the valve. Check for air going to valve. Check the valve to see if it changes position. If power is present, but valve does not change, replace the valve.

### 6.3.4 Platform Will Not Raise

If the optional lift platform does not raise when the UP button is pressed, use the table below to troubleshoot the problem.

1. Check for compressed air to the machine. Pressure should be 80 to 100 psi.
2. Check the PLC output to see if it is coming on to raise the platform.
3. Check the MAC valves for proper operation. The A coil should lift the platform. The B coil lowers the platform. The valves are driven by outputs from the PLC. When energized, the coils open the valves to either raise or lower the platform. If the PLC output is energized, 110 VAC should be present at the coil of the valve. Check for air going to valve. Check the valve to see if it changes position. If power is present, but valve does not change, replace the valve.
4. Check the cylinders for air leaks. This is done by taking the top line loose, then trying to raise platform. A little air should come out of cylinder until it gets to the top of its stroke, then air should stop coming out. If compressed air continues to come out when the cylinder is at the top of its stroke, the cylinder needs to be replaced.
5. Check the cables that run between the cylinders to make sure they are not broken. A broken cable may not keep the platform from rising, but could cause the platform to bind, which may damage one or both of the cylinders.

### 6.3.5 Container Weights are Erratic

If the bag weights are erratic, use the table below to troubleshoot the problem.

1. Check the linkage bars at the bottom of unit to make sure they are free and there is some play in them.
2. Check the cables on the platform for excessive slack and/or damage.
3. Check for product buildup around the lift cylinders or under the platform.
4. Check the weigh carriage for damage or interference that may cause weighing problems.
5. Check the platform lift cylinders for leaks. Leaks may cause the platform to bounce down as weight goes into bag.
6. Check the set points on the machine. Make sure that an adequate amount of dribble has been set for the machine to function properly. This setting should be approximately 150 to 300 pounds, depending on product.
7. Check the container size. If the container is too small, and product backs up into the neck, weighments will be erratic.
8. Check for proper product flow. If the product is bridging in the supply hopper and then falling out, or if the flow is erratic, weighments will be erratic.
9. Check the load cells for proper operation. A damaged or faulty load cell may cause the weight readings to fluctuate.
10. Check to make sure that the lift platform does not lift up against the pins during the fill. This will cause erratic weighments.

### **6.3.6 Scale is Not Accurate**

If the load cell is providing inaccurate readings, check the following:

1. Check for proper calibration. Refer to 3.7 Calibration.
2. Check the hopper to make sure an adequate supply of material is available in the product hopper to ensure a consistent head pressure.
3. Check to make sure there is nothing restricting material flow from the hopper.

### **6.3.7 Scale Does Not Return to Zero**

If the scale reading does not return to zero after package has been removed from the spout, check the following items:

1. Check the calibration. Refer to 3.7 Calibration.
2. Check for any outside interference, such as cords, hoses, etc., that would effect the movement of the weigh carriage.

### **6.3.8 The Weighments are Always Too Light**

Troubleshooting for weighments that are consistently coming up too light varies depending on the amount of time required to fill the package.

1. Try lowering the dribble weight value (SP1). The scale must have time to react, if material is coming in on the bulk rate too fast, the flow can cause a spike that will shut flow off too early.
2. Check the cutoff weight value (SP2) to make sure it is not set too low. If it is set too low, the product flow will be stopped too early and will cause consistently low weights.
3. Check the calibration. Refer to 3.7 Calibration.

### **6.3.9 Load Cell Fails Frequently**

If a load cell on an IBC-3000 fails frequently, check the following items:

1. Check the operating conditions to make sure that the load cell is not jarred, jerked, or being loaded with a sudden excessive force.
2. Check the load cell to make sure that the product being weighed does not exceed the rating of the load cell plus the dead load of the weighing mechanism.
3. Check the scale output to verify that the proper excitation voltage is applied to the load cell.

### 6.3.10 The Weighments are Always Too Heavy

If the machine consistently produces packages that exceed the target weight, use the table below to troubleshoot the problem.

1. Adjust the cutoff weight setting (SP2) to a lighter weight.
2. Make sure that there is a noticeable dribble period. The operator should see a noticeable slow down in product flow.
3. Validate that the weight displayed on the weight display equals the actual weight of the package. If the two weights are not equal, calibrate the machine. Refer to 3.7 Calibration.

### 6.3.11 The Weighments Fluctuate Between Too Light and Too Heavy

If the package weights fluctuate between too light and too heavy, use the table below to troubleshoot the problem.

1. Verify that the product flow is consistent and stable.
2. Check for consistent head pressure of product above the machine. Head pressure is the amount of product that is always in the hopper immediately above the IBC-3000. It is very important to keep the IBC-3000 from running out of material. As the IBC-3000 runs out of product the weighment accuracy will vary widely. Taylor Products recommends that a low level sensor be installed on the product hopper. If the low level condition is met then the fill routine should pause until more product is put in the hopper.
3. Verify a stable zero reading. The zero reading should not fluctuate more than a tenth. If the reading fluctuates more than a tenth there is a possible load cell or weight indicator problem. Refer to 6.3.7 Scale Does Not Return to Zero.
4. Verify that the weight display is displaying a stable weight reading. Hang a calibration weight or a known weight on the spout. If the weight display reading fluctuates more than a tenth or two it indicates a possible load cell or weight indicator problem.
5. Check the load cell connection points to ensure a good electrical connection tighten as needed.
6. Check each load cell individually to ensure they are matched. If each load cell is not matched via the summing board, the weights can vary by the amount of the difference. The readings from each load cell, with a weight hung on each individually, should be very nearly, if not exactly, identical. This can ONLY be corrected by recalibrating the scale and ensuring the load cell inputs are the same.
7. For systems equipped with the T3000, if the Smart Preact is on, and the parameter for Smart Preact Limit is set high, it may cause the final weights to “roller coaster”. This is due to the controller making large adjustments to the correction every cycle when only a small adjustment is required. If using Smart Preact, a small value for the limit, such as .25 is recommended. A smaller value will result in more cycles to correct, but will stop the control from over correcting.
8. Check the response of solenoids. The solenoids should respond immediately when voltage is applied.

## 6.4 System Alarms

During the filling process, conditions may occur that result in an alarm from the IBC-3000. Depending on the type of controller used, the alarms will vary.

### 6.4.1 T4000 Alarms

During the filling process, conditions may occur that result in one of the following T4000 alarms:

- A/D Failure Error! – An internal electronics error has occurred. Retry the operation. If the failure error re-occurs, power the machine down, then restart the machine and try the operation again. If the operation still fails, contact Taylor Products technical assistance.
- A/D Convert Error! – The input from the load cell is outside of the acceptable range. Check the load cell for damage. If a new load cell has been installed, check the rating of the load cell to make sure that the correct load cell has been installed.
- Motion Error! – The controller has detected that the vessel or product is in motion and the controller cannot finalize the weighment. Check the machine settings and retry.
- Trad Cal Error! – An error occurred during the calibration process. Try to calibrate the machine again. If the error occurs again, contact Taylor Products technical assistance.
- C2 Cal Error! – This error should not occur, as Taylor Products does not use C2<sup>®</sup> type load cells. If this error does occur, contact Taylor Products technical assistance.
- Too Lo Error! – Verify that the load cell signal level is 0-15 mV. Verify that there is enough weight on the scale. Perform Span then go back and Zero.
- Too Hi Error! – Verify that the load cell signal level is 0-15mV. Verify that there is not too much weight on the scale. Perform Span then go back and Zero.
- No C2 Sensor! – Instrument did not detect a C2<sup>®</sup> Load Sensor. This error should appear if C2<sup>®</sup> Cal is selected, as Taylor Products does not use C2<sup>®</sup> type load cells. If this error does occur, contact Taylor Products technical assistance.
- CAL Failed! – There are too few counts between Zero and Span. Reset either of the values, so that the counts are more than 1,000 counts of each other.
- C2 Caps Unequal! – This error should not occur, as Taylor Products does not use C2<sup>®</sup> type load cells. If this error does occur, contact Taylor Products technical assistance.
- HI/LO Too Close! – The Zero and Span values are not more than 1,000 counts from each other or there is no change, or there is a negative change. Reset either of the values, so that the counts are more than 1,000 counts of each other.
- Function Error! – The operator has pressed a function button and the function did not work. Try the function again. If it does not work, cycle the power off and on. If it still doesn't work, contact Taylor Products technical assistance.
- Not Allowed! – The value entered by the operator is outside of the range that is allowed. The operator should try another value that is within the acceptable range.
- Security Violation! – User signed in with a password that does not allow performance of a certain function or entry to certain menus. Security level of the user identified in the User ID, too low for the menu or function.
- Overrange – The final package weight has exceeded the set point target.
- Gross ADC Error – The controller has detected a load cell error. Check all load cell connections. Repair connections as necessary. Check the load cell for damage. Replace the load cell if necessary. Refer to 7.3.10 Load Cell Replacement.

## 6.4.2 T3000 Alarms

During the filling process, conditions may occur that result in an alarm from the T3000. There are three different categories of alarms:

- Fill Alarms
- Jog Alarms
- Filler Discharge Alarms

For a full description of these alarms, refer to Chapter 3: Operating Procedures/Filler, of the Taylor Products Filler/Dispenser/IBC T3000 User Guide, that is included in Appendix E of this manual.

## 6.5 PLC Error Messages

The Allen-Bradley MicroLogix™ 1100 has the ability to provide the following information:

- Status Messages
- Reminder Messages
- Warning Messages
- Fault Messages

To be able to access these messages, a properly equipped computer or handheld device must be connected to the PLC. Refer to the Allen-Bradley MicroLogix™ 1000 Programmable Controllers User Manual for detailed information on the error messages.

### 6.5.1 Status Messages

Status messages indicate to the operator that the control panel is performing an operation that may limit access to the terminal. Examples are application downloads or communication problems. The message disappears when the control panel completes the operation or when the condition is satisfied.

### 6.5.2 Reminder Messages

Reminder messages indicate a minor fault or mistake. Reminder messages appear when an invalid operation is attempted, such as entering an out-of-range value. Pressing any key removes the message.

### 6.5.3 Warning Messages

Indicates the operation may produce undesirable results. The operator must respond to warning messages as indicated in the message.

### 6.5.4 Fault Messages

Indicates the terminal has detected a condition, which will prevent further operation. The current application will stop. The operator must reset the terminal (power cycle) to recover from this type of error.

This Page Intentionally Left Blank

## Chapter 7

# Repair and Adjustment

### 7.1 General Description

When troubleshooting procedures have indicated that a component needs to be repaired, replaced, or adjusted, following the procedures in this chapter will assist maintenance personnel return the machine to operation in a timely manner.

### 7.2 System Adjustments

Depending on how the IBC-3000 is configured, there are several adjustments that may be required from time to time. They are:

- Air pressure adjustments
- Timer Adjustment

#### 7.2.1 Air Pressure Adjustments

The IBC-3000 requires compressed air to operate. Depending on options, the machine may have several different air pressure regulators. In its base configuration the machine will have two pressure regulators. This manual will focus on adjusting the two base regulators.

##### 7.2.1.1 Filter/Regulator/Lubricator (FRL) Assembly

The IBC-3000 requires compressed air at approximately 90-100 PSI (.62-.69 MPa) for proper operation. If air pressure is too high or too low, the air pressure regulator can be used to adjust the output air pressure. Turning the knob clockwise will increase the output air pressure. Turning the knob counter-clockwise will decrease the output air pressure.

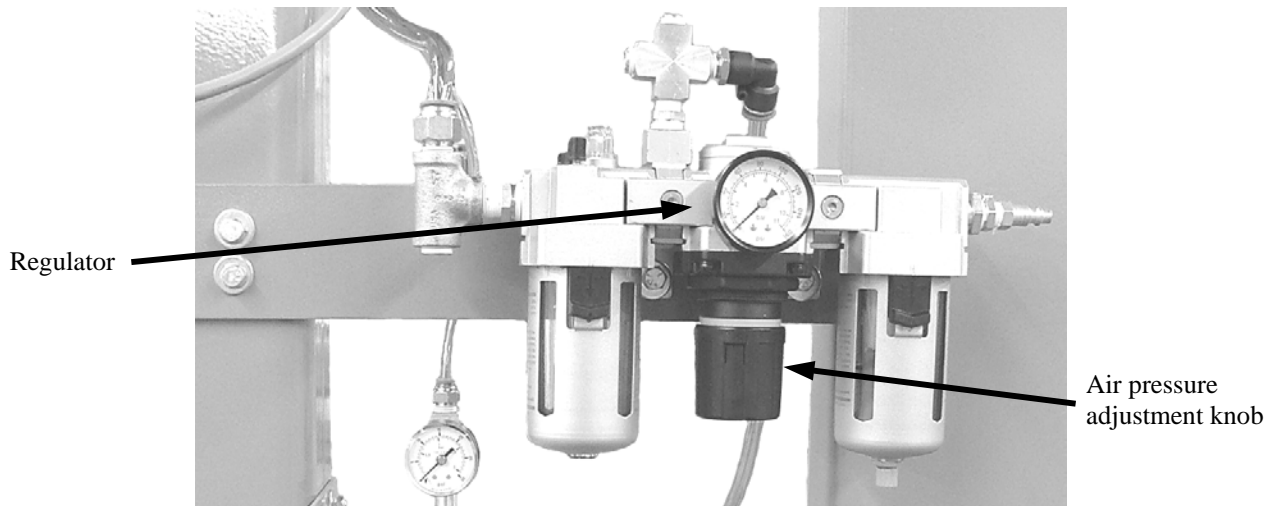

**Figure 7-1.** Air Filter/Regulator/Lubricator Assembly

### 7.2.1.2 Inflatable Neck Seal Air Pressure Regulator

Mounted below the FRL is a second air pressure regulator that controls the air pressure to the inflatable neck seal on the spout. This regulator is fed its air supply from a port on the FRL that is located between the filter and regulator. Turning the knob clockwise will increase the output air pressure. Turning the knob counter-clockwise will decrease the output air pressure. The secondary regulator should be set to 3 to 7 PSI (.02-.05 MPa).

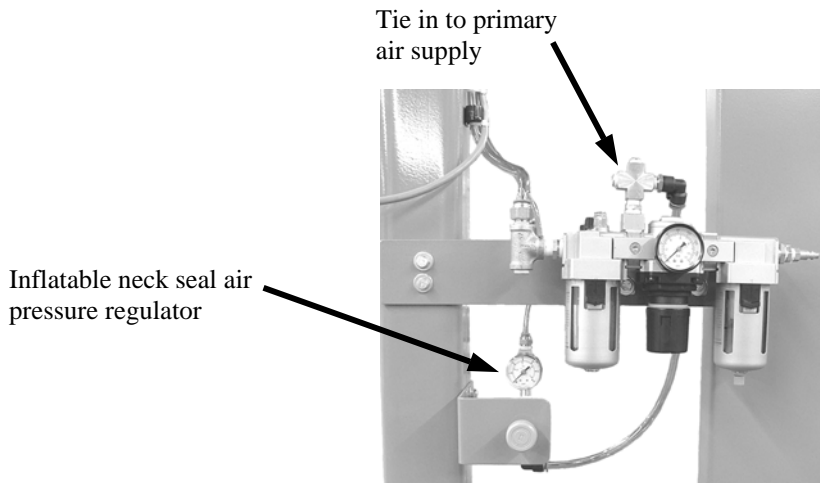

Figure 7-2. Inflatable Neck Seal Air Pressure Regulator

### 7.2.2 Timer Adjustments

The IBC-3000 has several operational features that are controlled via logical timers that are programmed into the PLC. Access to the timers and adjustment of the timers is accomplished using the PV300 control panel. Refer to 4.3.3.1 PV300 Menus, in Chapter 4 for more information on using the PV300.

## 7.3 System Component Replacement

Over time, components on the IBC-3000 may become worn or damaged. If this occurs, follow the procedures in this section to repair or replace individual components.



### **WARNING**

*When replacing parts, it is critical that only parts approved by Taylor Products are used.*

### 7.3.1 Spout Replacement

Due to the abrasiveness of some products, the spout will require periodic replacement. Use the procedures below to replace the spout.

#### 7.3.1.1 Spout Removal

1. Disconnect the power from the IBC-3000.
2. Disconnect the compressed air supply line from the IBC-3000 at the Filter/Regulator/Lubricator.
3. Disconnect the air line from the quick connect fitting on the spout.
4. Remove the nylon belt collar and the springs that hold it in position.
5. Disconnect the ductwork from the dust collection port on the spout.
6. Have a second person support the spout.
7. Remove the spout mounting bolts.
8. Remove the spout.

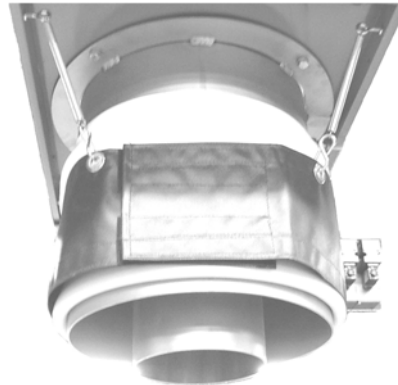

**Figure 7-3.** Spout

#### 7.3.1.2 Spout Installation

1. Lift the spout into position.
2. Align the mounting holes.
3. Install and tighten the mounting bolts.
4. Connect the air line at the quick connect fitting on the spout.
5. Install the nylon belt collar and springs.
6. Connect the ductwork to the dust collection port.
7. Connect the main air supply line to the Filter/Regulator/Lubricator.
8. Check all air supply connections for leaks.
9. Connect the power to the IBC-3000.
10. Check for proper operation.

## 7.3.2 Inflatable Bladder Replacement (Open Mouth Bag Spout)

The IBC-3000 is equipped with a spout with an inflatable bladder to prevent product and dust from escaping the bag. Over time, the inflatable bladder may become damaged or worn. Use the following steps to replace the inflatable bladder.

### 7.3.2.1 Inflatable Bladder Removal

1. Turn the IBC-3000 off.
2. Disconnect the input power and compressed air supply line.
3. Label and disconnect the air supply line from the quick connect fitting on the spout.
4. Remove the spout and place it upside down on a workbench. Refer to 7.3.1 Spout Replacement.
5. Fold the flap upward (away from the workbench) to expose the top compression ring.
6. Loosen the setscrew to release the tension on the top compression ring.



**Figure 7-4.** Loosening the Setscrew on the Top Compression Ring (Spout Removed From Machine)

7. Slide the top compression ring off of the spout.
8. Grasp the flap and pull upward (away from the workbench) to expose the bottom compression ring.
9. Loosen the setscrew to release the tension on the bottom compression ring.
10. Slide the bottom compression ring off of the spout.

*Note: Make note of how the bladder is positioned. The new bladder will need to be positioned in the same manner as the one that is being removed.*

11. Remove the bladder.
12. Inspect the compression rings for damage or wear. If they are damaged or worn, discard them and install new ones with the new bladder.

### 7.3.2.2 Inflatable Bladder Installation

1. Turn the new bladder inside out.
2. Slide the new inflatable bladder on to the spout. Position it on the spout in the same position as the old bladder.



**Figure 7-5.** Positioning the New Bladder on the Spout

3. Position the bottom compression ring.
4. Install the compression ring tensioning tool on the tail of the compression ring. Turn the crank handle on the tensioning tool clockwise to increase the tension on the compression ring.

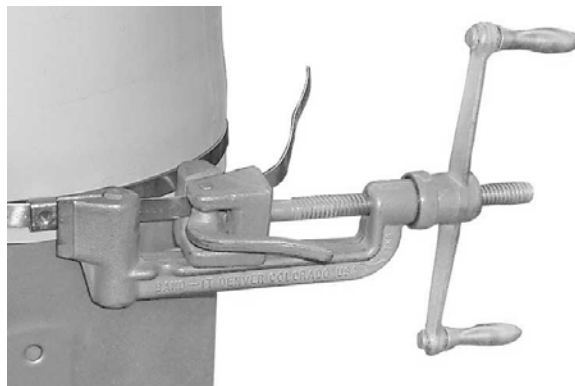

**Figure 7-6.** Using the Tensioning Tool

5. Install and tighten the setscrew for the bottom compression ring.
6. Remove the tensioning tool from the tail of the compression ring.
7. Trim the tail of the compression ring to about 2-inches. Fold the tail under and tuck it toward the setscrew block.



**Figure 7-7.** Tucking the Excess Compression Ring Under

8. Grasp the edge of the bladder that is not secured with a compression ring. Roll the edge outward and downward (toward the workbench), creating a flap. This motion will begin the process of turning the bladder right side out.
9. Pull the edge of the bladder downward (toward the workbench) until about 1-inch of the spout is exposed.



**Figure 7-8.** End of Spout Exposed

10. Roll the edge of the bladder outward and upward (away from the workbench, creating a new flap).
11. Pull the flap upward (away from the workbench) until it is positioned as shown in the following graphic.

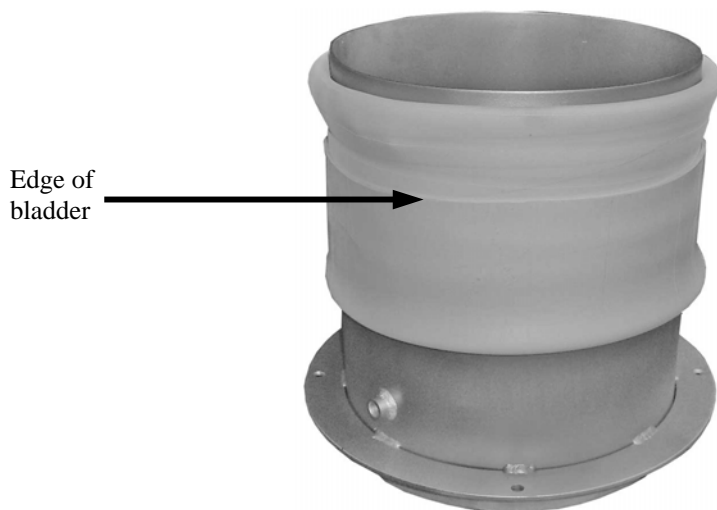

**Figure 7-9.** Positioning Flap So Upper Compression Ring Can Be Installed

12. Position the top compression ring.



**Figure 7-10.** Proper Positioning of the Top Compression Ring

13. Install the compression ring tensioning tool on the tail of the compression ring. Turn the crank handle on the tensioning tool clockwise to increase the tension on the compression ring.
14. Install and tighten the setscrew for the top compression ring.
15. Remove the tensioning tool from the tail of the compression ring.
16. Trim the tail of the compression ring to about 2-inches. Fold the tail under and tuck it toward the setscrew block.
17. Pull the flap down to cover the top compression ring.



**Figure 7-11.** Flap Covering the Top Compression Ring

18. Install the spout. Refer to 7.3.1 Spout Replacement.
19. Connect the air supply lines to the quick connect fittings on the spout.
20. Connect the main pneumatic and electrical connections.
21. Turn the IBC-3000 on and test for proper operation.

## 7.3.2 Air Supply Line Replacement

In the event that an air supply line becomes damaged and requires replacement, follow the steps below to remove and replace the air supply line.

### 7.3.2.1 Air Supply Line Removal

1. Disconnect the main power cord.
2. Disconnect the main air supply line from the IBC-3000.
3. Disconnect the ends of the air supply line that is being replaced from the components that it is connected to. Press in on the fitting collar and hold it in while pulling the air supply line free.
4. Remove any clips and/or retainers that hold the air supply lines in place.
5. Remove the air supply line, making note of how the line is routed.

### 7.3.2.2 Air Supply Line Installation

1. Measure the air supply line that was just removed.
2. Cut a new length of air supply line, making sure that the ends of the line are cut square. Cut the new line to the same length of the one that was removed.
3. Route the new air supply line in the same manner as the one that was removed.
4. Insert each end of the new line into their fittings.
5. Reattach any clips and/or retainers to secure the air supply line.
6. Reconnect the main air supply line and check for any leaks. If a leak is found, disconnect the main air supply line and then disconnect/reconnect the leaking air connections, then reconnect the main air supply line. Repeat as necessary, until no leaks are present.
7. Reconnect the main power cord.

## 7.3.3 Air Fitting Replacement

In the event that an air fitting becomes damaged and requires replacement, follow the steps below to remove and replace the air supply line.

### 7.3.3.1 Air Fitting Removal

1. Disconnect the main power cord.
2. Disconnect the main air supply line from the IBC-3000.
3. Disconnect the air supply line from the fitting by pressing in on the collar while pulling out on the air supply line.
4. Using a wrench, unscrew the fitting.

### 7.3.3.2 Air Fitting Installation

1. Using Teflon® tape, wrap the threads of the new fitting, starting at the bottom of the thread working toward the hex head in the same direction as the threads.
2. Screw the new fitting into the threads and use a wrench to carefully tighten the fitting.



#### **CAUTION**

Over tightening the fitting can damage the fitting, or the component that it is being threaded into.

---

---

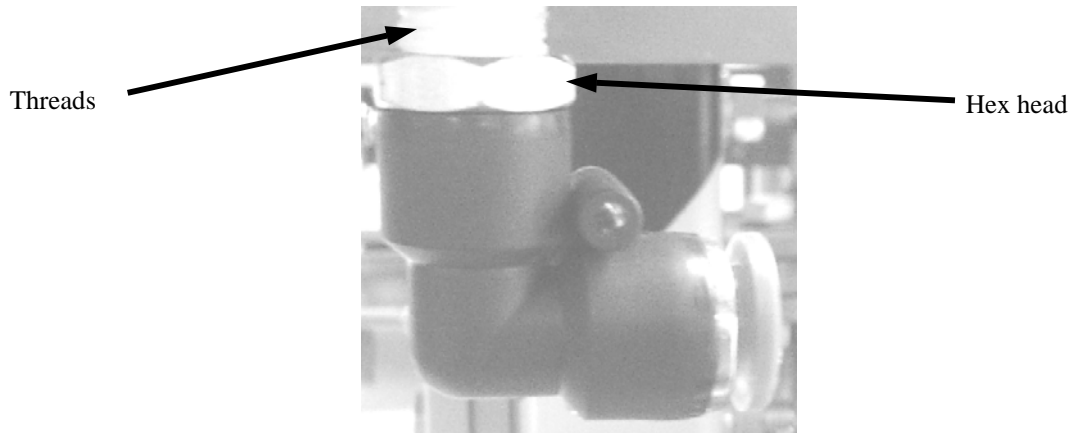

**Figure 7-12.** Air Supply Fitting

3. Reconnect the air supply line to the fitting.
4. Reconnect the main air supply line and check for any leaks. If a leak is found, disconnect the main air supply line and then disconnect/reconnect the air connections, then reconnect the main air supply line. Repeat as necessary, until no leaks are present.
5. Reconnect the main power cord.

### 7.3.4 Air Filter/Regulator/Lubricator (FRL) Replacement

In the event that the filter, the regulator, or the lubricator experiences a malfunction or becomes damaged, use the procedures below to replace the entire assembly.

#### 7.3.4.1 FRL Assembly Removal

1. Disconnect the power from the IBC-3000.
2. Disconnect the compressed air supply line from the IBC-3000 at the filter.
3. Disconnect the output compressed air line from the lubricator.
4. Disconnect the output compressed air line between the filter and regulator.
5. Remove the FRL mounting bolts and remove the FRL.
6. Drain the oil from the lubricator and discard it in accordance to local laws.

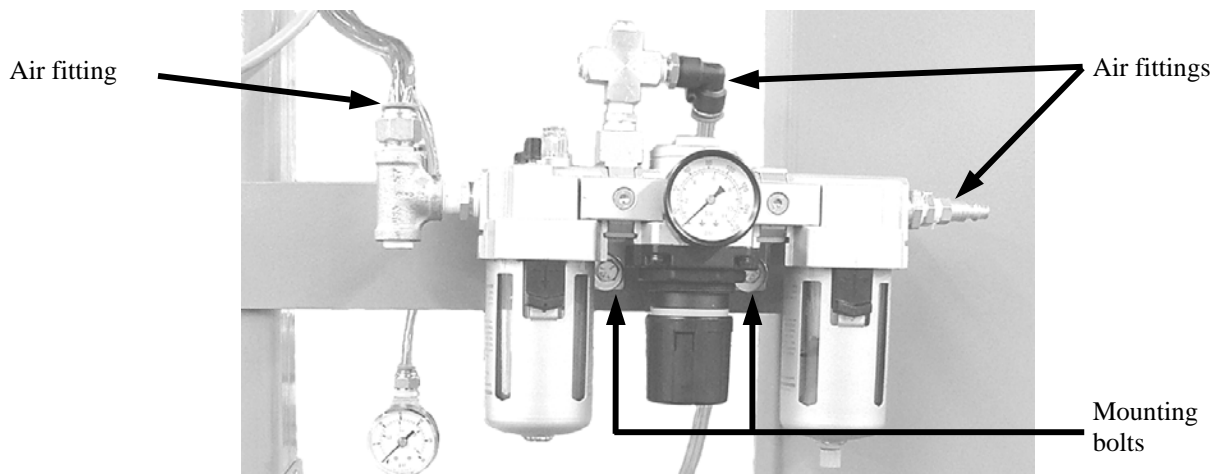

**Figure 7-13.** FRL Assembly

## Repair

### 7.3.4.2 FRL Assembly Installation

1. Position the new FRL in the mounting location. Install and tighten the mounting bolts.
2. Connect the compressed air output line to the lubricator.
3. Connect the compressed air output line between the filter and regulator.
4. Fill the lubricator with the appropriate oil.
5. Connect the compressed air supply line to the filter.
6. Check for air leaks.
7. Connect the power to the IBC-3000.
8. Check the IBC-3000 for proper operation.

### 7.3.5 MAC Valve Replacement

In the event that troubleshooting indicates that a MAC valve has failed, follow the procedures below to replace it.

#### 7.3.5.1 MAC Valve Removal

1. Disconnect the power from the IBC-3000.
2. Disconnect the compressed air supply line from the IBC-3000 at the filter.
3. Disconnect the air line from the quick connect fitting on the MAC valve.
4. Remove the two mounting screws.
5. Unplug and remove the MAC valve.

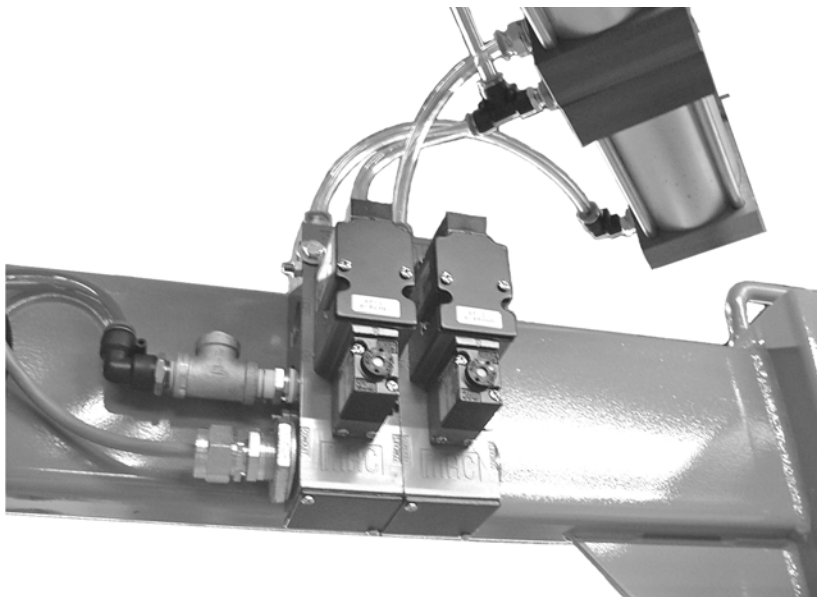
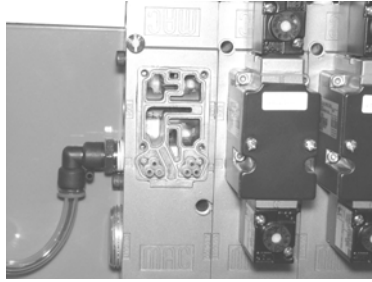

Figure 7-14. MAC Valves

### 7.3.5.2 MAC Valve Installation

1. Position the new MAC valve and plug it in.



**Figure 7-15.** MAC Valve (Solenoid Removed)

2. Install and tighten the two mounting screws.
3. Connect the air line to the quick connect fitting on the MAC valve.
4. Connect the compressed air supply line to the IBC-3000 at the filter.
5. Connect the IBC-3000 to its primary power supply.
6. Test for proper operation.

### 7.3.6 Lift Platform Pneumatic Cylinder Replacement

If a lift platform pneumatic cylinder fails to function or develops a leak, follow the procedures below to replace it.

#### 7.3.6.1 Lift Platform Pneumatic Cylinder Removal

1. Lower the lift platform to its lowest position.
2. Insert the platform support pins to support the platform once the lift cylinders are disconnected.
3. Disconnect the IBC-3000 power connections.
4. Disconnect the main air supply from the FRL.
5. Loosen the lower two nuts to release the cable bracket. Take time to loosen one nut a little, then switch to the second nut. Switch back and forth until the nuts are removed. This is done to prevent binding the cable bracket.
6. Remove the remaining nuts from the bolts.
7. While holding the lift cylinder upright, remove the four long bolts and washers from the lift cylinder.



**Figure 7-16.** Lift Cylinder Mounting Nuts.

## Repair

8. Tilt the cylinder toward the center of the IBC-3000.
9. Use the access holes and remove the cotter pin and the clevis pin.

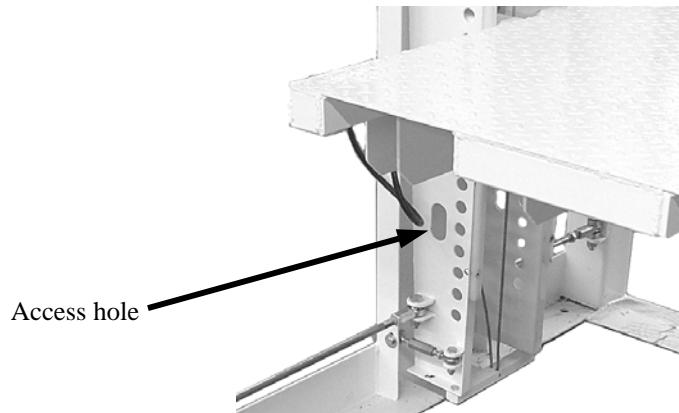

**Figure 7-17.** Access Hole for Lift Cylinder Lower Clevis Pin

10. Remove the lift cylinder.

### 7.3.6.2 Lift Platform Pneumatic Cylinder Installation

1. Position the clevis end of the cylinder into the lift platform.
2. Insert the clevis pin through the platform bracket and the eye on the end of the shaft.
3. Secure the clevis pin with a cotter pin.
4. Tilt the lift cylinder up into its final position.
5. Position the washers and insert the mounting bolts.
6. Install and tighten the four mounting nuts.
7. Install two nuts on the two inboard mounting bolts. They should be threaded up the bolt almost all the way.
8. Position the cable bracket onto the two inboard mounting bolts, so that the cable set screw is inboard.
9. Install the two cable bracket retaining nuts. Tighten the two nuts evenly to prevent the cable bracket from binding. Tighten the nuts until tension on the cable is restored to a point where it is equal to the tension on the cable on the opposite lift cylinder.
10. Tighten the cable bracket lock nuts down onto the cable bracket.

## 7.3.7 Platform Carriage Cable Replacement

In the event that a platform carriage cable breaks or becomes otherwise damaged, follow the procedures below to replace the cable.

### 7.3.7.1 Platform Carriage Cable Removal

1. Set the platform support pins.
2. Turn the IBC-3000 off and disconnect the power and air supplies.
3. Loosen the setscrews on each end of the cable. Back the setscrews out to allow the cable to slide freely.
4. Slide each end of the cable out of its respective block.
5. Remove the cable from the IBC-3000.

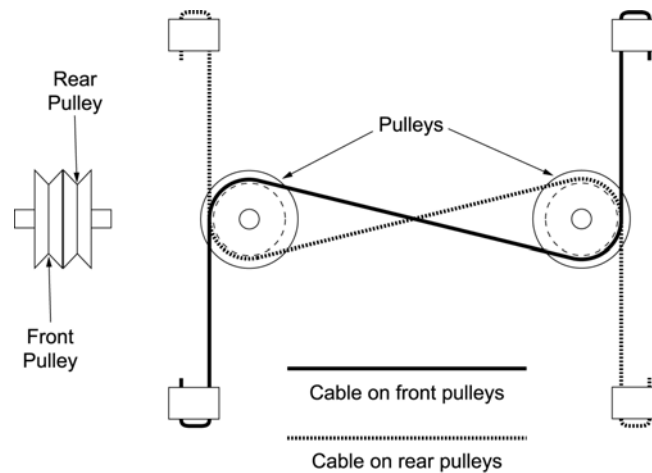

Figure 7-18. Platform Carriage Cable Routing

### 7.3.7.2 Platform Carriage Cable Installation

1. Insert one end of the new cable into the upper block from the bottom, leaving approximately two inches of excess.
2. Tighten the setscrew to secure the cable.
3. Tuck the excess cable into the second hole in the block.
4. Route the other end of the cable under the platform and under the pulley. Route the cable into the groove in the pulley that is not being used by the second cable.

**Important:** The cables should run parallel with one another. They should not come in contact with each other. If the cables were allowed to cross, it would result in binding and would adversely affect the operation of the lift platform.

5. Route the cable to the other end of the platform and over the pulley on that end.
6. Route the end of the cable down through the lower block.
7. Pull the cable tight, and tighten the setscrew.
8. Tuck the excess cable into the second hole in the block.

## 7.3.8 Platform Carriage Pulley Replacement

In the event that a platform carriage pulley breaks or becomes otherwise damaged, follow the procedures below to replace the pulley.

### 7.3.8.1 Platform Carriage Pulley Removal

1. Turn the IBC-3000 off and disconnect the power from the machine.
2. Disconnect the main air supply line from the machine.
3. Raise the platform and insert the platform support pins below the platform.
4. Lower the platform so that it is resting on the support pins.
5. Loosen the setscrew on the top bracket for each pulley cable to remove the tension on the cable. Slide the end of the cable out of the top bracket. Refer to 7.3.7 Platform Carriage Cable Replacement.
6. Slide the pin and pulley assembly out of the mounting brackets.
7. Slide the outer spacer on the side of the pulley being replaced off of the pin.
8. Slide the pulley off of the pin.

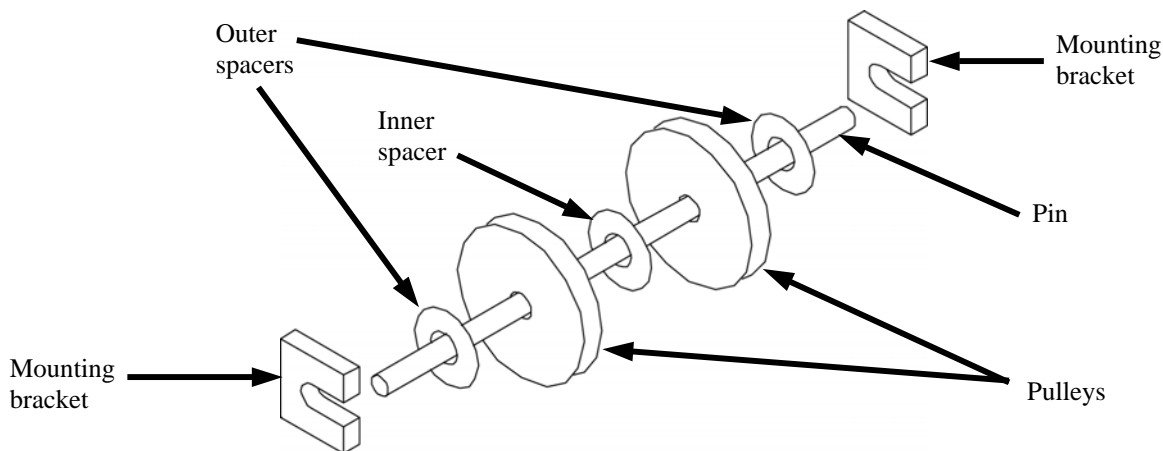

Figure 7-19. Platform Carriage Pulley

### 7.3.8.2 Platform Carriage Pulley Installation

1. Slide the new pulley onto the pin.
2. Slide the outer spacer on to the pin and position it against the pulley.
3. Slide the pin and pulley assembly into the mounting brackets.
4. Route the cables through the pulleys.
5. Insert the cables into the top brackets and secure using the setscrews. Refer to 7.3.7 Platform Carriage Cable Replacement.
6. Connect the air supply line to the IBC-3000.
7. Connect the IBC-3000 power connections.
8. Turn the IBC-3000 on and lift the platform.
9. Remove the platform support pins.
10. Check for proper operation of the lift platform.

### 7.3.9 Lift Platform Proximity Switch Replacement

IBC-3000 units that are equipped with a lift platform will also have a lift platform proximity switch to indicate the position of the platform. If the proximity switch fails or becomes damaged, use the procedures below to replace it.

#### 7.3.9.1 Lift Platform Proximity Switch Removal

1. Turn the IBC-3000 off and disconnect the machine from the power source.
2. Place a mark or tag on the C-channel to mark the operating position of the proximity switch.
3. Loosen the bolt and slide the sensor and bracket down to the bottom of the channel.
4. Place one hand under the channel and slide the bracket the rest of the way out of the channel.
5. Use a screwdriver to remove the two screws that mount the switch to the bracket.
6. Note the location of each of the wires where they connect to the control panel.
7. Disconnect the wires from the control panel.
8. Remove any tie straps or clips retaining the cable and remove the cable/switch from the machine.

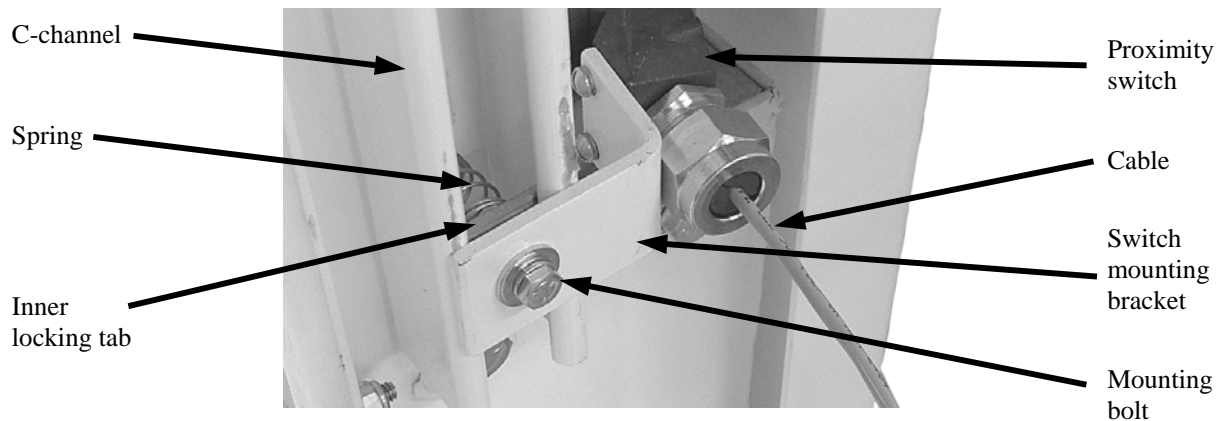

Figure 7-20. Lift Platform Proximity Switch

#### 7.3.9.2 Lift Platform Proximity Switch Installation

1. Position the new proximity switch so the bracket can be attached.
2. Install and tighten the two mounting screws that mount the switch to the bracket.
3. Compress the spring and slide the bracket into the lower portion of the C-channel. The C-channel has a lip on each side. The inner locking tab should be inside of the lip, while the bracket is outside of the lip.
4. Slide the proximity into the operating position, indicated by a mark or tag that was placed during the switch removal, and tighten the mounting bolt.
5. Route the cable to the control panel in the same route as the proximity switch that was removed. Secure the cable in the same manner as the cable for the switch that was removed. Allow enough slack in the cable to allow the platform to move up and down without damaging the cable.
6. Using the notes taken during the proximity switch removal, connect the cable wires to the control panel in the same configuration as the proximity switch that was removed.
7. Connect the machine to its power source.
8. Turn the machine on and test for proper operation.

## 7.3.10 Load Cell Replacement

If a load cell fails, follow the procedures below to replace it.



### CAUTION

Failure to support the weigh carriage when replacing load cells can result in damage to the other two load cells.

### 7.3.10.1 Load Cell Removal

1. Turn the IBC-3000 off.
2. Disconnect the main electrical and air connections.
3. Locate the electrical cable for the load cell being replaced. Note the routing of the cable and trace it to the control panel.
4. Note the individual wires from the cable and how they are connected to the control panel.
5. Disconnect the load cell cable from the control panel.
6. Route the cable back to the load cell so it can be removed with the load cell.
7. Support the weigh carriage in the area of the load cell that is being replaced.
8. Remove the lower mounting bolt, nut, and washer.
9. Remove the upper mounting bolt, nut, and washer.
10. Remove the load cell.

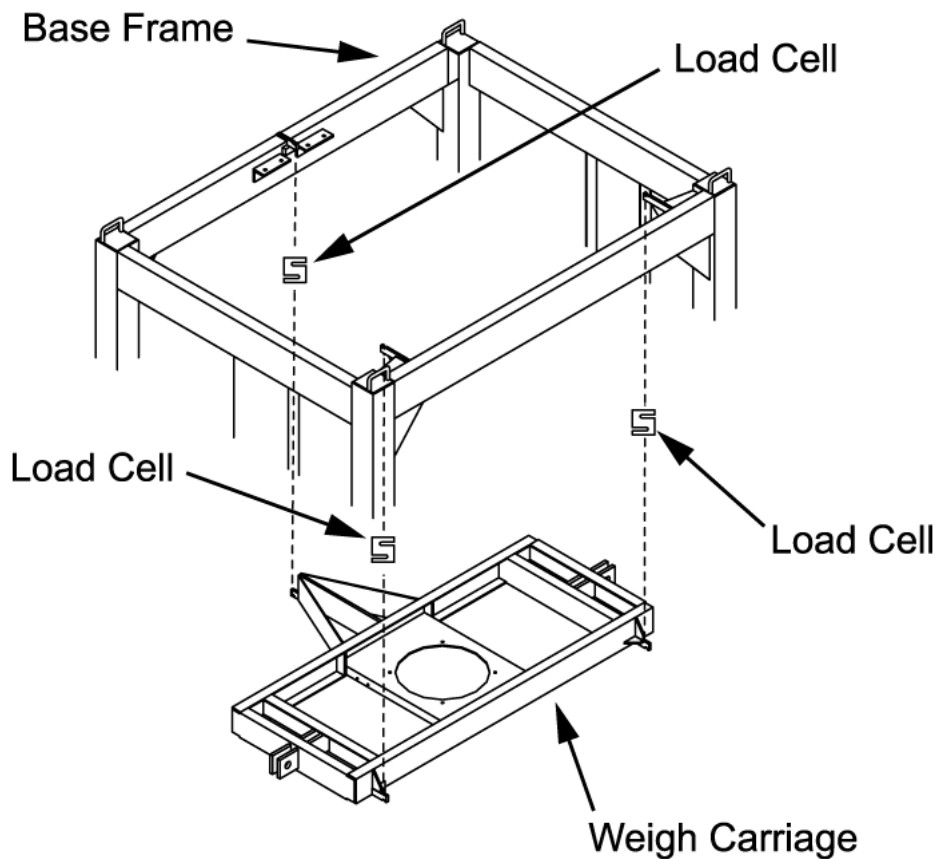

Figure 7-21. Load Cell Arrangement

### 7.3.10.2 Load Cell Installation

1. Insert the upper link of the new load cell into the bracket on the frame.
2. Insert the bolt through the bracket and upper link. Install the washer and nut on the bolt.
3. Position the lower link of the new load cell into the bracket on the weigh carriage.
4. Insert the bolt through the bracket and lower link. Install the washer and nut on the bolt.
5. Remove the temporary weigh carriage support.
6. While holding the load cell mounting bolts with a wrench, tighten the nuts.
7. Check the weigh carriage for level. Adjust the new load cell as necessary to level the weigh carriage.
8. Route the cable to the control panel. Be careful to route the cable as the old cable was routed.
9. Connect the wires in the cable to the board in the control panel.
10. Connect the IBC-3000 main air and electrical connections.
11. Turn the IBC-3000 on.
12. Calibrate the machine. Refer to 3.7 Calibration.
13. Test for proper operation.

### 7.3.11 Vibratory Settler Replacement

The IBC-3000 uses two different types of vibratory settling devices. One type is electronic, while the other type is pneumatic. If a vibratory settler fails, use the procedures below to replace it.

#### 7.3.11.1 Electronic Vibratory Settler Removal

1. Turn the IBC-3000 off.
2. Disconnect the IBC-3000 from its main power and air supply connections.
3. Disconnect the electrical connection for the settler at the control panel.
4. Note the routing of the electrical cable for the settler.
5. Pull the electric cable through the machine toward the settler until it is completely free.
6. Support the settler.
7. Remove the mounting bolts, nuts, and washers.
8. Remove the settler.



**Figure 7-22.** Electronic Vibratory Settler

### **7.3.11.2 Electronic Vibratory Settler Installation**

1. Position the settler and support it.
2. Install the mounting bolts, nuts, and washers.
3. Route the electric cable through the machine as the cable from the other settler was.
4. Connect the electrical cable to the control panel.
5. Connect the IBC-3000 main power and air supply connections.
6. Turn the IBC-3000 on and test for proper operation.

### **7.3.11.3 Pneumatic Vibratory Settler Removal**

1. Turn the IBC-3000 off.
2. Disconnect the IBC-3000 from its main power and air supply connections.
3. Disconnect the air supply line for the settler at the quick connect fitting.
4. Support the settler.
5. Remove the mounting bolts, nuts, and washers.
6. Remove the settler.

### **7.3.11.4 Pneumatic Vibratory Settler Installation**

1. Position the settler and support it.
2. Install the mounting bolts, nuts, and washers.
3. Connect the air supply line cable to the quick connect fitting on the settler.
4. Connect the IBC-3000 main power and air supply connections.
5. Turn the IBC-3000 on and test for proper operation.

## **7.3.12 Knife Gate Assembly Replacement**

Depending on the abrasiveness of the product that is being packaged, the knife gate housing may become worn. If the knife gate housing needs replaced, follow the procedure below.

### **7.3.12.1 Knife Gate Assembly Removal**

1. Turn off the IBC-3000.
2. Disconnect the main electrical and air supply connections.
3. Remove the bolts, nuts, and washers that secure the product supply hopper to the knife gate assembly.
4. Disconnect the product supply hopper.
5. Disconnect the knife gate shaft clevis bolts and nuts at the knife gate. Retract the knife gate shaft.
6. Remove the bolts, nuts, and washers that secure the knife gate assembly to the inlet flange.
7. Remove the bolts, nuts, and washers that secure the knife gate assembly to the knife gate cylinder mounting bracket.
8. Remove the bolts, nuts, and washers that secure the knife gate assembly to the inlet flange.
9. Remove the knife gate housing.
10. Remove the bolts, nuts, and washers that hold the knife gate in the knife gate housing.
11. Pull the knife gate out of the knife gate housing.

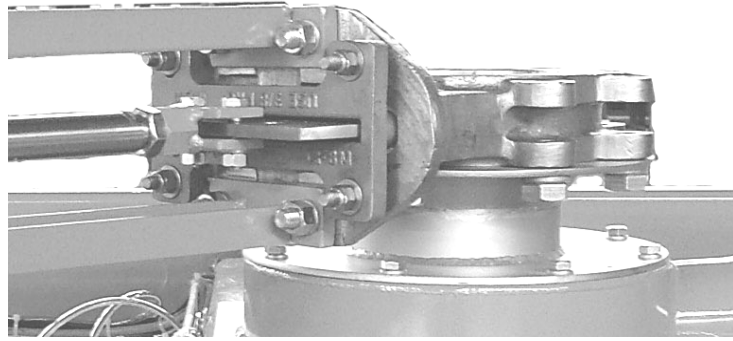

**Figure 7-23.** Knife Gate Mounting

### **7.3.12.2 Knife Gate Assembly Installation**

1. Slide the knife gate into the new housing.
2. Install the bolts, nuts, and washers to secure the knife gate in the knife gate housing.
3. Tighten the knife gate to knife gate housing bolts.
4. Position the knife gate to inlet flange gasket.
5. Position the knife gate assembly.
6. Install the bolts, nuts, and washers that secure the knife gate assembly to the inlet flange.
7. Tighten the knife gate to inlet flange mounting bolts.
8. Install the bolts, nuts, and washers that secure the knife gate assembly to the knife gate cylinder mounting bracket.
9. Tighten the knife gate to knife gate cylinder mounting bracket bolts.
10. Extend the knife gate shaft so it can be connected to the knife gate.
11. Install the bolts, nuts, and washers that secure the knife gate shaft clevis to the knife gate.
12. Tighten the knife gate shaft clevis to knife gate retaining bolts.
13. Position the product supply hopper to knife gate gasket.
14. Position the product supply hopper on the knife gate.
15. Install the bolts, nuts, and washers that secure the product supply hopper to the knife gate.
16. Tighten the product supply hopper to knife gate mounting bolts.
17. Connect the main air and power supply connections.
18. Turn the IBC-3000 on and test it for proper operation.

### **7.3.13 Knife Gate Replacement**

Depending on the abrasiveness of the product that is being packaged, the knife gate may become worn. If the knife gate needs replaced, follow the procedure below.

#### **7.3.13.1 Knife Gate Removal**

1. Turn off the IBC-3000.
2. Disconnect the main electrical and air supply connections.
3. Disconnect the knife gate shaft clevis bolts and nuts at the knife gate. Retract the knife gate shaft.
4. Remove the bolts, nuts, and washers that secure the knife gate to the knife gate housing.
5. Slide the knife gate out of the knife gate housing.

### 7.3.13.2 Knife Gate Installation

1. Slide the knife gate into the knife gate housing.
2. Install the bolts, nuts, and washers that secure the knife gate to the knife gate housing.
3. Tighten the knife gate to knife gate housing bolts.
4. Extend the knife gate shaft so it can be connected to the knife gate.
5. Install the bolts, nuts, and washers that secure the knife gate shaft clevis to the knife gate.
6. Tighten the knife gate shaft clevis to knife gate retaining bolts.
7. Connect the main air and power supply connections.
8. Turn the IBC-3000 on and test it for proper operation.

### 7.3.14 Knife Gate Cylinder Replacement

If the knife gate cylinder fails to function and all other possible causes have been eliminated, an internal failure may have occurred. Follow the procedures to replace the cylinder.

#### 7.3.14.1 Knife Gate Cylinder Removal

1. Turn the IBC-3000 off.
2. Disconnect the IBC-3000 main electrical and air connections.
3. Label and disconnect the air lines from the quick connect fittings on the knife gate cylinder.
4. Disconnect the clevis from the knife gate.
5. Support the knife gate cylinder and remove the mounting bolts.
6. Remove the cylinder.



Figure 7-24. Knife Gate Cylinder

#### 7.3.14.2 Knife Gate Cylinder Installation

1. Position the new gate cylinder.
2. Insert the knife gate cylinder mounting bolts and tighten.
3. Extend the cylinder shaft.
4. Connect the clevis to the knife gate.
5. Connect the air supply lines to the quick connect fittings.
6. Connect the IBC-3000 main electrical and air connections.
7. Turn the IBC-3000 on.
8. Test the IBC-3000 for proper operation.

### 7.3.15 Bag Strap Hanger Release Rod Replacement

If one of the bag straphanger rods becomes damaged, use the procedures below to replace it.

#### 7.3.15.1 Bag Strap Hanger Release Rod Removal

1. Turn the IBC-3000 off.
2. Loosen the locking collar setscrews on the rod that is being replaced.
3. Slide the rod out, being careful to retrieve each locking collar as it slides off the rod.

#### 7.3.15.2 Bag Strap Hanger Release Rod Installation

1. Slide the rod in.
2. As the rod slides in and clears the release brackets, slide the locking collars on to the rod.
3. Position the rod and locking collars.
4. Tighten the setscrews.
5. Turn the IBC-3000 on and test for proper operation.

### 7.3.16 Bag Strap Hanger Automatic Release Cylinder Replacement

If the bag straphanger automatic release cylinder fails to function, and the cause has been determined as an internal failure of the cylinder, follow the procedures below to replace the cylinder.

#### 7.3.16.1 Bag Strap Hanger Automatic Release Cylinder Removal

1. Turn off the IBC-3000.
2. Disconnect the main electrical and air supply connections.
3. Disconnect the air supply line at the quick connect fitting on the cylinder.
4. Loosen the locking collar set screw that secures the actuator bracket to the cylinder shaft and slide the locking collar off the shaft.
5. Slide the actuator bracket off of the cylinder shaft.
6. Loosen the locking collar set screw on the second locking collar and slide it off the shaft.
7. Hold the cylinder while using a wrench to break the cylinder mounting nut loose.
8. Remove the mounting nut.
9. Remove the pneumatic cylinder.

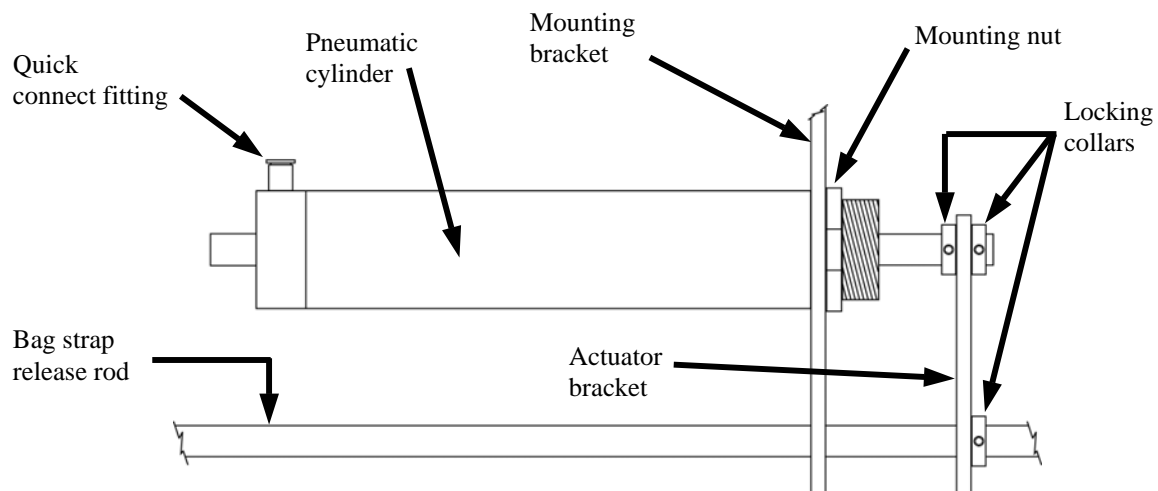

Figure 7-25. Bag Strap Hanger Automatic Release Cylinder Mounting

### **7.3.16.2 Bag Strap Hanger Automatic Release Cylinder Installation**

1. Insert the new cylinder into the mounting bracket. Position the quick connect fitting on top.
2. Hold the cylinder in position and install the mounting nut.
3. While holding the cylinder in position, use a wrench to tighten the mounting nut.
4. Slide one locking collar on to the cylinder shaft.
5. Slide the actuator bracket on to the cylinder shaft.
6. Slide the locking collar on to the cylinder shaft and tighten the setscrew.
7. Position the actuator bracket so it is vertical and just touching the locking collar release rod.
8. Slide the inner locking collar so it is just touching the actuator bracket and tighten the setscrew.
9. Slide the outer locking collar so it is tight against the actuator bracket and tighten the setscrew.
10. Connect the air supply line to the quick connect fitting on the cylinder.
11. Connect the main air and power supply connections.
12. Turn the IBC-3000 on and check for proper operation.

## Glossary

<b>TERM</b>	<b>DEFINITION</b>
AC	Alternating Current
Audible alarm	The sounding of a bell, buzzer, beeper, or other acoustic device to draw the attention of the operator to a system fault.
Bagging cycle	A series of functions that describe the packaging process, from beginning to end, for one package of product.
Base frame	The portion of the machine that provides the support structure for all other components that make up the machine.
Bulk rate	The fill speed used to package the largest portion of the product. It is a fast fill speed. Also referred to as Fast A.
Component	An item of hardware as commonly supplied complete by manufacturers.
Contact	A conducting part that co-acts with another conducting part to open or close an electrical circuit
Counter	A device that counts the occurrence of some event.
Cubic Feet/Minute (CFM)	A unit of measure that is used to describe the amount of compressed air that is used by a machine.
DC	Direct Current
De-energize	To deprive an electro-receptive device of its operating current.
Display	A device that gives information in visual form.
Dribble rate	The fill speed used to package the smallest portion of the product. It is a slow fill speed, as compared to the bulk rate. Also referred to as Slow A.
Dual set point	Refers to a machine that has the capability of delivering the product at two different fill speeds.
ESD	Electrostatic Discharge
Failure	The event, or inoperable state, in which any item or part of an item does not, or would not perform as specified.
Fill rate	A general term used to describe the speed at which the product is being fed.
Fine dribble rate	On some units equipped with a digital control panel, a third feed rate is available. This speed is slower than the dribble rate. Also referred to as Slow B.
Ground	Ground (Electrical). A conducting connection, whether intentional or accidental, between an electrical circuit or equipment and the earth, or some other conducting body at a reference potential.
h, HR	Hour
I/O	Input/Output
IN or in.	Inch or inches
Jog	The function of adding a small amount of product to a package that ended up being underweight at the end of the bagging cycle.
kg	Kilogram
Knife gate	The mechanism that controls when the product is allowed to flow from the surge hopper in to the package. This mechanism also controls how fast that product is allowed to flow.
lb or lbs	Pound or pounds
LCD	Liquid Crystal Display
LED	Light Emitting Diode. Used as status indicator for many types of equipment (processors, power supplies, I/O modules, modems, etc).
Load cell	An electronic device that is used to monitor the weight of the product that is being packaged.
MAC valve	A pneumatic valve that is used for controlling various pneumatic cylinders. The valves apply air pressure to the cylinders causing them to either open or close.
Module	Assembly of components, which function as a unit and can be replaced as a unit.
OPC	OLE for Process Control
PLC	Programmable Logic Controller

## Glossary

<b>TERM</b>	<b>DEFINITION</b>
Pounds per Square Inch (PSI)	Unit of measure used to describe air pressure.
POWER ON indicator	A lamp that will illuminate when power has been turned on.
Power supply	A device that converts available power to a form that a system can use — usually converts AC power to DC power.
Processor	The decision-making and data storage sections of a programmable controller or computer.
Product	Refers to the material that is being packaged by the machine.
Reaction time	The time used by equipment, operator, or both, that elapses between the moments an action is called for and when the desired result occurs.
Refrigerated air dryer	A device that uses a refrigeration unit to remove moisture from a compressed air supply. This is done to reduce corrosion and contamination of the pneumatic equipment.
Relay	An electromagnetic device that is operated by a variation in the conditions of one electric circuit, to effect the operation of other devices in the same or another electric circuit.
RS-232	An EIA standard that specifies electrical, mechanical, and functional characteristics for serial binary communication circuits. A single-ended serial communication interface.
Safety-Critical	Any condition, event, operation, process, component, assembly, subsystem, or system, the failure or malfunction of which can result in severe injury, severe occupational illness, or major damage.
Set point	A control setting that is used to define a transition point in the fill process. It can be a point when a change in fill rate occurs, or when the machine stops filling all together.
Set Point 1 (SP1)	The control setting that defines where the bulk feed rate is to stop.
Set Point 2 (SP2)	The control setting that defines where the dribble rate stops. Is typically slightly lower than target weight.
Shipping bracket	A piece of metal that is used to secure the weighing apparatus to the base frame during shipping to prevent damage to the weighing apparatus.
STOP button/indicator	Used by the operator to immediately stop the machine. It is a large red button that illuminates when the stop button has been pressed. To restart the machine the button is pulled out.
Surge	A sudden rise of current or voltage.
Surge hopper	A reservoir where product is stored for packaging.
T3000	An electronic control device that was jointly developed by Taylor Products and Hardy Instruments. This is an optional controller for weighing applications.
T4000	An electronic control device that was jointly developed by Taylor Products and Hardy Instruments. This is the standard controller for weighing applications.
Target weight	The desired package weight.
VAC	Volt, alternating current
VDC	Volt, direct current
Water separator	A device that is installed in a compressed air supply line to remove excess moisture from the air supply. This is done to reduce corrosion and contamination of the pneumatic equipment.
Weighment	One charge or fill of a packaging machine.
Weight display	An electronic device that is used to display package weights and to set package parameters.

## Index

Adjustable Locking Bag Strap Hangers, .....	1-5	Inflatable Bladder Replacement (Open Mouth Bag Spout), .....	7-4
Air Filter/Regulator/Lubricator (FRL) Replacement, .....	7-9	Inflatable Neck Seal Air Pressure Regulator, .....	7-2
Air Fitting Replacement, .....	7-8	Inlet Flange, .....	1-3
Air Pressure Adjustment, .....	7-1	Introduction, .....	1-1
Air Supply Line Replacement, .....	7-8	Knife Gate Assembly Replacement, .....	7-18
Bag Liner Inflators, .....	1-20	Knife Gate Cylinder Replacement, .....	7-20
Bag Strap Hanger Automatic Release Cylinder Replacement, .....	7-21	Knife Gate Replacement, .....	7-19
Bag Strap Hanger Release Rod Replacement, .....	7-21	Lift Platform, .....	1-21
Calibrating The Optional T3000 Control Panel, .....	3-14	Lift Platform Cables, .....	1-22
Calibrating the T4000 Control Panel, .....	3-8	Lift Platform Pneumatic Cylinder Replacement, .....	7-11
Calibration, .....	3-8	Lift Platform Proximity Switch Replacement, .....	7-15
Check All Fasteners, .....	5-1	Lift/Weigh Platform, .....	1-23
Cleaning, .....	5-1	List of Figures, .....	ix
Control Box With T3000 Control Panel, .....	4-5	List of Tables, .....	xi
Control Box With T4000 Control Panel, .....	4-3	Load Cell Connections with T3000 Control Panel, .....	1-19
Control Panel User Guide, .....	7-1	Load Cell Connections with T4000 Control Panel, .....	1-18
Conventions, .....	i	Load Cell Replacement, .....	7-16
Conveyors, .....	1-25	Lubrication Requirements, .....	3-1
Custom Features, .....	7-1	MAC Valve Replacement, .....	7-10
Daily Maintenance Procedures, .....	5-1	MAC Valves, .....	1-15
Drain Water From the Water Separator, .....	5-2	Machine Controls, .....	1-7
Drum Filling Attachments, .....	1-24	Main Frame, .....	1-3
Electrical and Pneumatic Drawings, .....	7-1	Major Systems and Components, .....	1-2
Electrical Connections, .....	3-1	Making Network Connections, .....	3-2
Electrical Requirements, .....	1-1	Manual Scope, .....	1-1
Electro Static Discharge, .....	ii	Mechanical Drawings, .....	7-1
Electronic Load Cell Weighing System, .....	1-17	Mechanical Setup, .....	3-2
Electro-static Discharge (ESD) Prevention Procedures, .....	ii	Monthly Maintenance, .....	5-2
Establishing Security Settings, .....	3-3	Non-Weighing Controls, .....	1-7
Establishing T3000 Security Settings, .....	3-6	Non-Weighing IBC-3000, .....	4-1
Establishing T4000 Security Settings, .....	3-3	Operation, .....	4-1
Field Service, iii		Operational Controls, .....	4-3
Filter/Regulator/Lubricator (FRL) Assembly, .....	7-1	Operational Modes, .....	4-13
General Fill Cycle Information, .....	4-1	Optional Remote Bag Strap and Neck Seal Release, .....	1-6
Glossary, .....	7-1	Optional T3000 Weighing Controls, .....	1-11
Important/Notable Information, .....	ii	Pallet Dispenser, .....	1-24
Inflatable Bag Spout with Nylon Belt Collar, .....	1-4	PanelView (PV300) Controls, .....	4-7
		Personal Safety Instructions, .....	ii

## Index

Platform Carriage Cable Replacement, .....	7-13
Platform Carriage Pulley Replacement, .....	7-14
Platform Lift Cylinders, .....	1-16
PLC Error Messages, .....	6-7
Pneumatic Connections, .....	3-1
Pneumatic Pressure Regulators, .....	1-15
Pneumatic Requirements, .....	1-1
Pneumatic System Components, .....	1-15
Pre-Calibration, Mechanical Check Procedures, .....	3-8
Preventive Maintenance, .....	5-1
Product Description, .....	1-1
Purge Kit, .....	1-26
Purge Kit Maintenance, .....	5-2
PV300 Menus, .....	4-7
Receiving Equipment, .....	2-1
Repair and Adjustment, .....	7-1
Safety Alert Symbols, .....	i
Safety Procedures, Cautions, Warnings, and Notices, .....	7-1
Setting Up A Non-Weighing IBC-3000, ....	4-11
Setting Up A Weighing IBC-3000 With A T3000 Control Panel (Optional), .....	4-12
Setting Up A Weighing IBC-3000 With A T4000A Control Panel, .....	4-11
Settlers, .....	1-23
Setup/Installation, .....	3-1
Spare Parts, .....	7-1
Spout Replacement, .....	7-3
Standard T4000 Weighing Controls, .....	1-8
Starting the Unit, .....	4-17
Static Sensitive Symbols for Equipment Handling Instructions, .....	i
Step Sequence, .....	1-19
System Adjustments, .....	7-1
System Alarms, .....	6-6
System Component Replacement, .....	7-3
T3000 Alarms, .....	6-7
T4000 Alarms, .....	6-6
T4000 Calibration, .....	3-10
Table of Contents, .....	v
Timer Adjustments, .....	7-2
Trouble Symptoms, .....	6-1
Troubleshooting, .....	6-1
Troubleshooting Process, .....	6-1
Typical Fill Cycle, .....	4-2
Uncrating the Equipment, .....	2-1
Using the Control Panel, .....	4-11
Vibratory Settler Replacement, .....	7-17
Warranty Information, .....	iii
Weighing IBC-3000, .....	4-1



## Appendix A

### Safety Procedures, Cautions, Warnings, and Notices

- General safety precautions must be observed during all phases of operation, service and repair of the IBC-3000. Failure to comply with these precautions or with specific warnings elsewhere in this manual violates safety standards of design, manufacture and intended use of the IBC-3000.
- The manufacturer assumes no liability for customer's failure to comply with the following requirements:
  - Qualified technicians and maintenance personnel should service the equipment described in this manual.
  - Do not attempt internal service or adjustments unless another person, capable of rendering first aid and resuscitation, is available.
  - Do not substitute parts or modify equipment. This practice could, in some cases, introduce the danger of additional hazards
  - The IBC-3000 contains some electrostatic-sensitive components. Therefore, always ground yourself with a proper wrist strap before handling any modules or printed circuit boards so that static charges are removed from the person. Use static suppressive packaging to protect electronic assemblies removed from the IBC-3000.
  - Observe all procedural cautions and warnings located on the equipment and throughout this manual.
  - Read and follow all instructions
  - Follow all warnings and instructions marked on the units and listed in manuals.

This Page Intentionally Left Blank

## Appendix B Spare Parts

**Table B-1. IBC-3000 Spare Parts List**

	<b>Part Description</b>	<b>Part Number</b>
1	Rubber Sleeve	50-7477
2	Canvas Belt Shield	50-7479
3	MAC Solenoid Valve	50-1729
4	MAC Solenoid Valve	50-1831
5	MAC Solenoid Valve	50-1832
6	Lift Platform Carriage Cables	60-3070
7	Carriage Pulley	50-7344
8	Pulley Pin	60-3041
9	Potentiometer	50-1721
10	Load Cell Barrier	
11	Mounting Rail	
12	Insulating Spacer	
13	Earth Terminal	
14	Knife Gate 6"	
15	Knife Gate Cylinder	
16	Lift Cylinder	50-1093
17	Air Vibrator	
18	Load Cells	50-1547
19	Filter/Regulator/Lubricator (FRL)	
20	Lubricator	
21	Control Enclosure Nema 4 X S-S	
22	Solenoid Enclosure	
23	Release Cylinder	
24	Push buttons, Black Nema 7-9, Flush Mount	
25	Enclosure Nema 7-9	
26	Cover (2) Hole	
27	Purge Kit for CL I Div II Group C&D	
28	¼" Flush Connection	
29	Mounting Kit	
30	Protection Vent	
31	Warning Name Plate	

This Page Intentionally Left Blank

# Appendix C

## Mechanical Drawings

Table C-1. IBC-3000 Mechanical Drawings

	Drawing Title	Part Number
1		
2		
3		
4		
5		
6		
7		
8		
9		
10		

This Page Intentionally Left Blank

# Appendix D Electrical and Pneumatic Drawings

Table D-1. IBC-3000 Electrical and Pneumatic Drawings

	Drawing Title	Part Number
1		
2		
3		
4		
5		
6		
7		
8		
9		
10		

This Page Intentionally Left Blank

# **Appendix E**

## **Control Panel User Guide**

This Page Intentionally Left Blank

This unit was ordered without a weighing mechanism, thus the control panel user guide is not needed and not included.

This Page Intentionally Left Blank

## **Appendix F**

### **Custom Features**

The documents included in Appendix F will provide information regarding any custom features that were ordered and included in the equipment purchase.

This Page Intentionally Left Blank

The equipment that accompanies this manual was not ordered with any custom features, thus no custom documentation is included.

This Page Intentionally Left Blank