

REVISION HISTORY			
REV	DESCRIPTION	DATE	APPROVED
A	UPDATED BRKT CHART	11/5/2013	HM

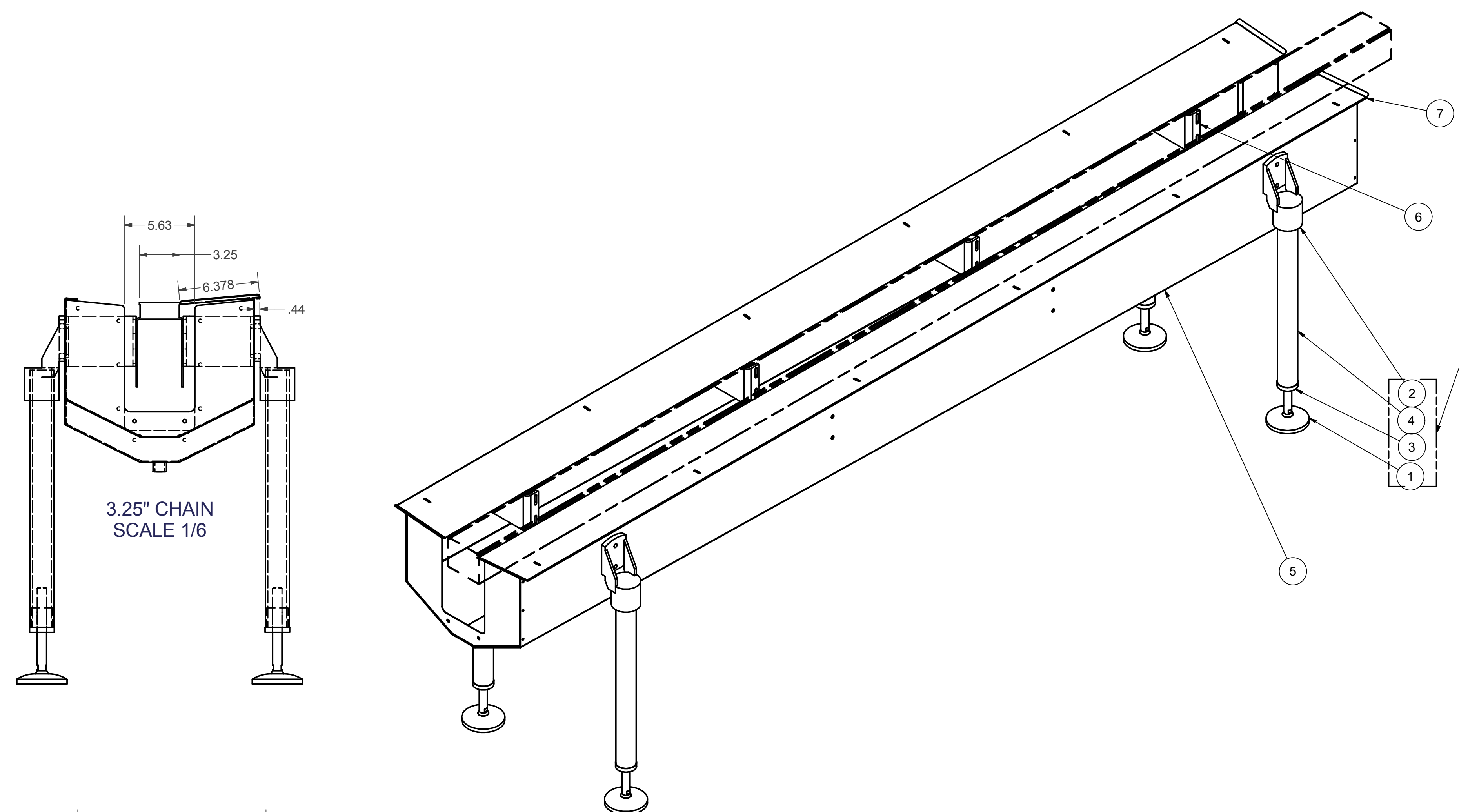

QTY CHANGES DEPENDING ON TUNNEL STAND (2 FOR CANTILEVER 4 FOR NON-CANTILEVER)

ASSY#	TUBE QTY	CONV W	PAN BRKT#	BRKT W	JOB REF	DRIP LIP	CHAIN W	SPACER	NOTES
KST-110-100-01	4	5.00	R21-50T105-12	5.00		KST-111-109	4.50	none	
KST-110-100-02	4	5.25	R21-50T105-02	4.88	946	KST-111-109		none	
KST-110-100-03	4	3.75	R21-50T105-11	5.63	948	KST-111-109	3.25	none	
KST-110-100-04	4	4.00	R21-50T105-13	5.50	956	KST-111-109		none	
KST-110-100-05	2	5.00	R21-50T105-12	5.00	973	KST-111-109	4.50	none	
KST-110-100-06	2	4.50	R21-50T105-05	5.25	977	KST-111-109		none	
KST-110-100-07	2	3.75	R21-50T105-11	5.63	987	KST-111-109	3.25	none	
KST-110-100-08	2	4.88	R21-50T105-07	5.06	995	KST-111-109	4.38	none	
KST-110-100-09	4	5.00	R21-50T105-12	5.00	993,1006	KST-111-109	4.50	none	
KST-110-100-10	2	3.35	R21-50T105-11	5.63	1034	KST-111-109	3.27	R21-50T107-01	
KST-110-100-11									
KST-110-100-12	4	4.25	R21-50T105-17	5.38	1187	KST-111-109	3.25	none	
Tube L= Conv H - 10		BrktW = 0.5*(15 - ConvW)							

ITEM	QTY	PART#	DESCRIPTION 1	DESCRIPTION 2
8	8	SEE CHART	SPACER	
7	2	KST-111-1XX	TRAY LIP 110	
6	8	R21-50T105-XX	DRIP PAN MTG BRKT	
5	1	KST-111-100	DRIP PAN 110" WELD&CAULK	ANGLED TOP
4	T QTY	PDC-221AXX	SUPPORT TUBE,L x1.9DIA	1.900D X 1.68ID
3	T QTY	ME1217	THREADED TUBE END VG-551-B34	FOR 1.9"ODX1.69ID PIPE,3/4"THD
2	T QTY	ME1051	POST CAP VG-305-1.50	VALU GUIDE
1	T QTY	ME1009	BASE VG-511-02-S34 L7 ME1020	VALU GUIDE S/S-3/4-10 THRD

Parts List

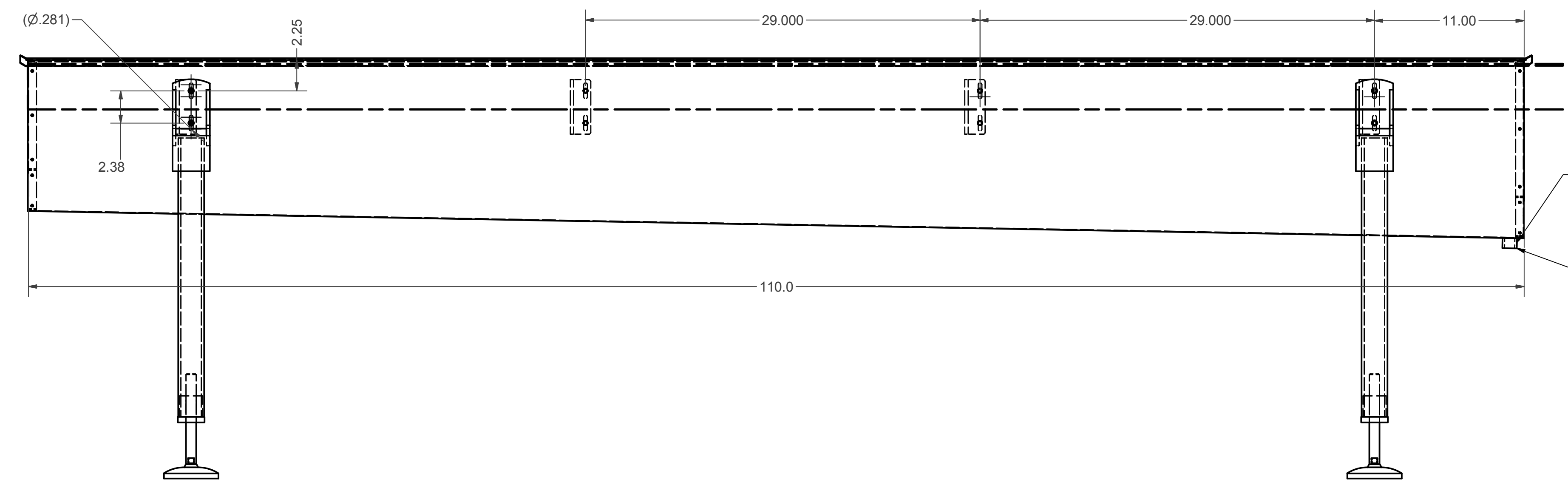
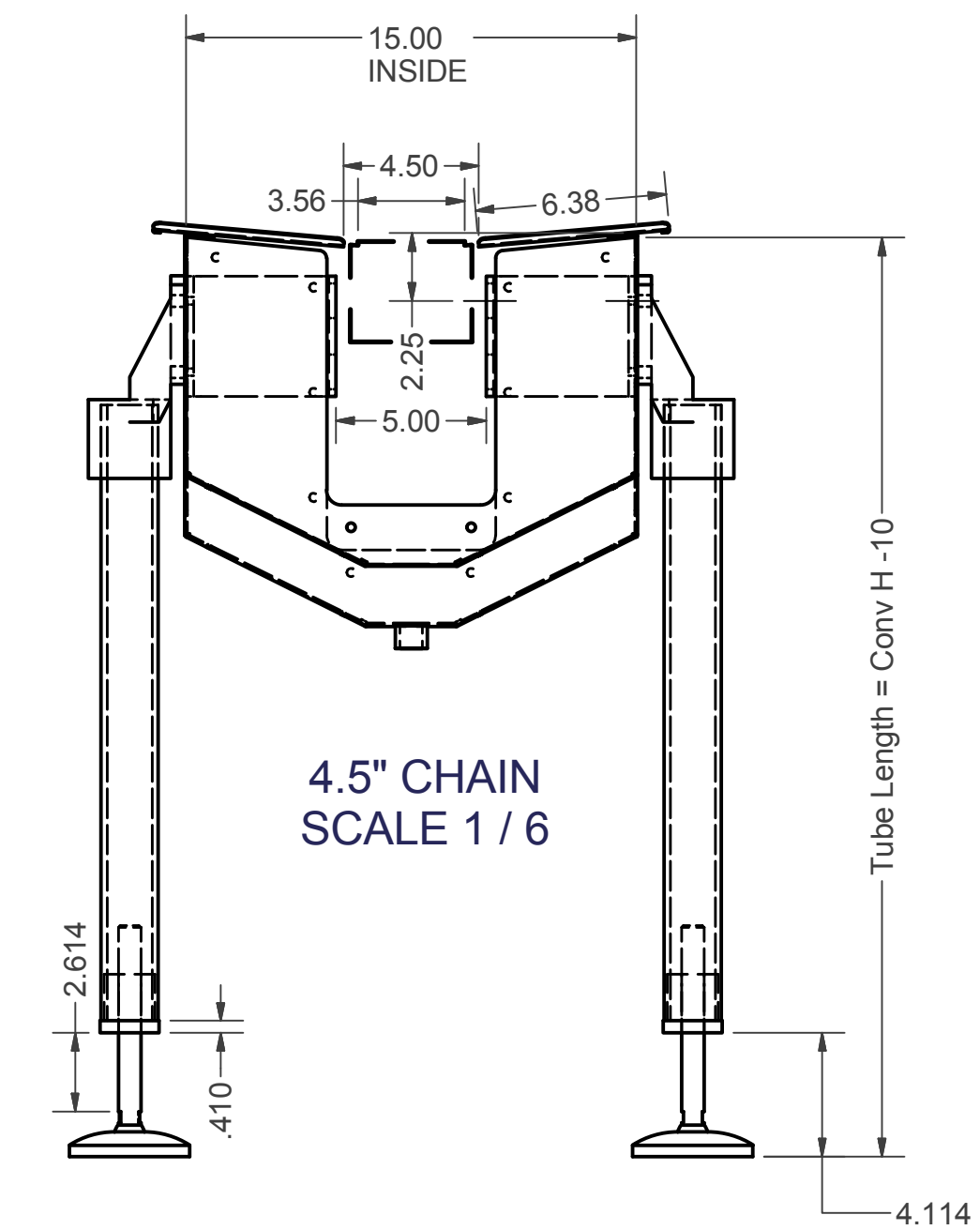
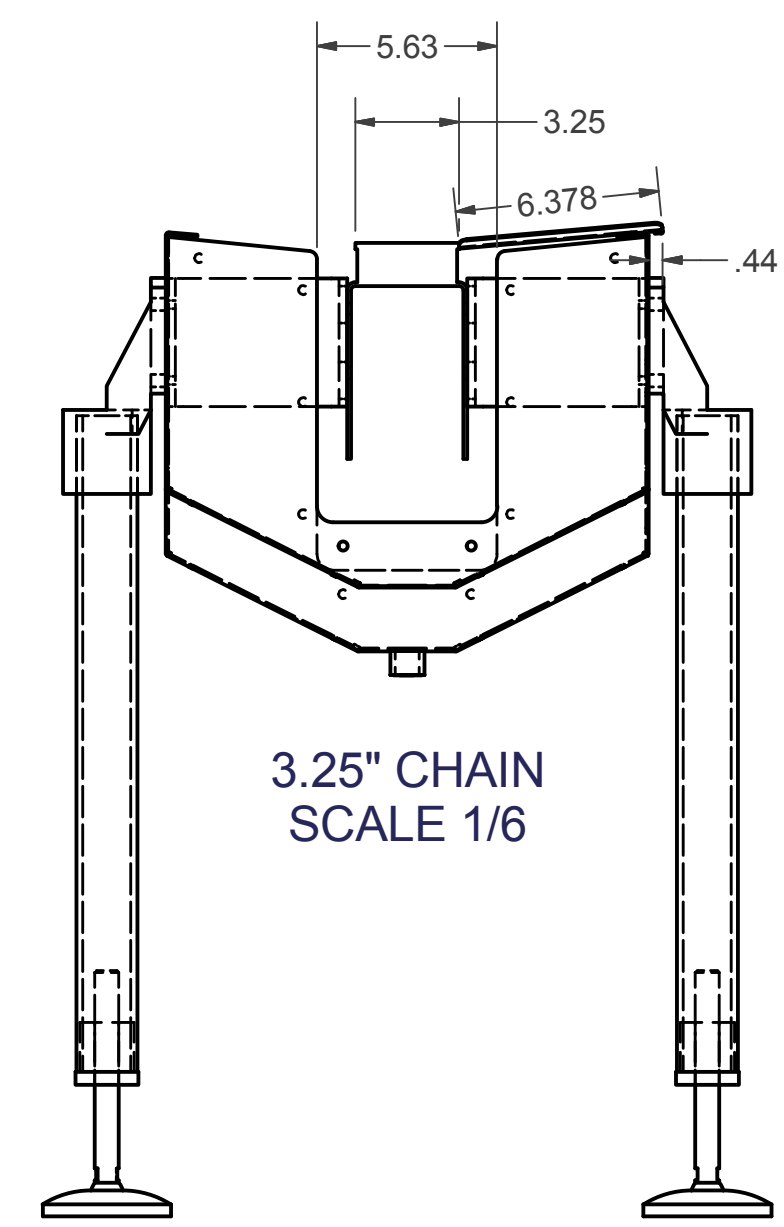

(TRAY SUB ASSY DWG CALLS OUT FITTING TO WELD AND END CAP CAULKING)

<small>MACHINED DIMENSIONS UNLESS OTHERWISE SPECIFIED: FILLETS R 1/32, EDGES BREAK .005 SURFACE FINISH 63 MICROFINISH FRAC. TOL ± 1/64 DEC. TOL (XXX±.015, XXX±.010, XXX±.005) ANG. TOL ± 0'30"</small>		TITLE DRIP PAN ASSY 15"x110" SINGLE		 <small>8 SHEERAN AVENUE NORWALK, CONNECTICUT 06854 USA</small>	
USED ON	SCALE	DWN R Morse	DATE 5/31/2008	SIZE	DRAWING NUMBER
JOB #	QTY	CHKD	DATE	D	KST-110-100-XX
		APPR	DATE		SHT # 1 OF 1