

## BAG INSERTER ZIM-11

From a roll of polyethylene film, the compact ZIM-11 automatically inserts bags into boxes, crates or trays.

The bag inserter runs with **made-to-measure bags** or **pre-made bags from a reel** and is available in mono and multi box footprint.

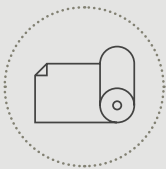
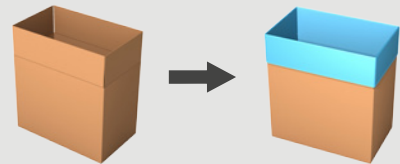

made-to-measure  
bags from a reel

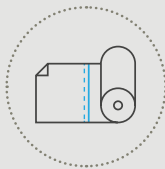

pre-made bags  
from a reel

SOF  
seal off first



### Case lining convenience

- Continuous production thanks to the **automatic film roll exchange**.
- Super **compact**: only 1,2 x 1 m floor space needed.

### Your intelligent bag inserter

- **Up to 8 cases/minute**.
- Integrated automatic **bag detection**.
- **Elimination of operator errors** thanks to fully automatic format change.
- Quick and **ergonomic film roll loading**.



Watch our videos  
at [pattyn.com](http://pattyn.com)

# TECHNICAL SPECIFICATIONS ZIM-11

## Made-to-measure bags from a reel

- Continuous tubular gusseted film on a reel.
- Impulse sealing for a controlled and clean seal.

## Pre-made bags from a reel

- Pre-sealed and perforated bags on a reel for optimal convenience.

## Failsafe bag opening

- Mechanical grippers instead of delicate vacuum cups.

## Perfectly controlled bag insertion

- Case flap holders for perfect case flap positioning.
- Spoons with integrated bag detection system.
- Smart box lift for vertical box positioning.

## Use of stepper motor technology

- Self-resolving.

## Standard equipped with:

- Colour touch panel for easy operation.
- Infeed conveyor with integrated box centering device and separator.



Mechanical grippers & spoons with bag detection



Case flap holders



Integrated bag detection

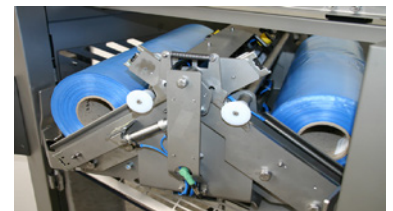

Automatic film roll exchange (optional)



Super compact

### CONTAINER SPECIFICATIONS (For other dimensions, please contact Pattyn)

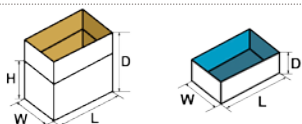
Type	Boxes, trays and crates
Range (L x W // D) mm	<b>Mono or multi footprint (L x W) /variable heights</b> Min. 300 (L) x 200 (W) // 200 (D) Max. 605 (L) x 405 (W) // 600 (D)
	Outside dimensions

### FILM SPECIFICATIONS

Type	Tubular film with gussets
Thickness	As from 15 µm
Weight of film roll	Max. 12 kg
Outside diameter film roll	Max. 230 mm
Inside diameter of core	76 mm

### OUTPUT AND CONSUMPTION

Output ZIM with made-to-measure bags	Up to 8 c/min
Output ZIM with pre-made bags	Up to 6 c/min
Installed power	2 kW
Voltage	3 x 400 V + N + E / 50 Hz
Air supply	6 bar / 1/2" min
Air consumption	45 Nl / cycle
Weight	500 kg

### OPTIONS (More options are available, please contact Pattyn)

Automatic film roll exchange	Advanced stainless steel execution
Multi colour warning light	Air plunger for improved bag positioning
Modifications to the box lift to run crates with open bottom	Access point for remote support

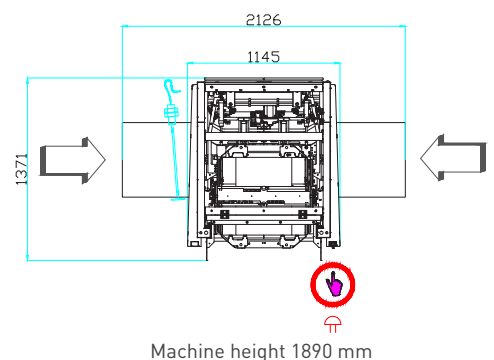

Pattyn Packing Lines nv  
Industriepark 'Blauwe Toren'  
Hoge Hul 2, 8000 Brugge - Belgium

T +32 (0) 50 450 480  
info@pattyn.com  
www.pattyn.com



The description, pictures and information given have an indicative value. We reserve the right to make changes without notice. Information and content is property of Pattyn. For customised executions please contact Pattyn. ZIM-11 2017 - V03

**PATTYN**<sup>®</sup>

Turnkey solutions for industrial packaging.