



Care & Maintenance Manual for All Catbridge Machines



Catbridge Machinery, LLC
115 Main Road
Montville, NJ 07045
Phone (973) 808-0029
Fax (973) 808-0076
www.catbridge.com

November, 2021

TABLE OF CONTENTS

INTRODUCTION	1
SAFETY.....	3
<i>Understanding Safety Labels</i>	<i>3</i>
<i>Read Instructions</i>	<i>4</i>
<i>Safe Machine Operation.....</i>	<i>4</i>
MACHINE LABELS.....	9
MACHINE MAINTENANCE SCHEDULES	13
<i>Daily</i>	<i>13</i>
<i>Weekly</i>	<i>13</i>
FREQUENCY	14
<i>Monthly (or 500 Hours)</i>	<i>14</i>
FREQUENCY	15
<i>Semi-Annual (or 3000 Hours).....</i>	<i>15</i>
<i>Annual (or 6000 Hours)</i>	<i>15</i>
CALIBRATION PROCEDURES.....	16
<i>Loadcells (Dover Flexo Electronics)</i>	<i>16</i>
<i>Positioning.....</i>	<i>16</i>
<i>Amplifier.....</i>	<i>17</i>
<i>HMI</i>	<i>18</i>
<i>Adjusting variable pitch pulley</i>	<i>20</i>
LEVELING AND ALIGNMENT.....	22
<i>Leveling and Securing.....</i>	<i>22</i>
<i>Touch Roll Alignment (Catbridge 900)</i>	<i>24</i>
<i>Touch Roll Alignment (Catbridge 901/902/344).....</i>	<i>26</i>
<i>Rewind Shaft Alignment (Catbridge 729).....</i>	<i>27</i>
<i>Rewind Shaft Photo-eye Alignment (Catbridge 729).....</i>	<i>30</i>
<i>Rewind Shaft Gap mode sensor adjustment (Catbridge 729).....</i>	<i>32</i>

TABLE OF CONTENTS

MECHANICAL SUBSYSTEMS AND MAINTENANCE	33
<i>General Lubrication Tips.....</i>	<i>33</i>
<i>Maintenance Schedules.....</i>	<i>33</i>
<i>Differential Mandrel (Shaft) - Camlock Style.....</i>	<i>33</i>
<i>Direct Friction Differential Mandrel (Shaft) - Goldenrod/Tidland.....</i>	<i>35</i>
<i>Lock Core Mandrel (Shaft) - Goldenrod</i>	<i>36</i>
<i>Shear Knives Maintenance Schedule.....</i>	<i>45</i>
<i>Troubleshooting: Knifemaker Performance.....</i>	<i>46</i>
<i>Troubleshooting: Shear Slitting (Slit Quality)</i>	<i>47</i>
<i>Troubleshooting: Shear Slitting (Slit Quality) Continued.....</i>	<i>48</i>
<i>Score Knives Maintenance Schedule</i>	<i>54</i>
<i>Troubleshooting: Knifemaker Performance.....</i>	<i>55</i>
<i>Troubleshooting: Knifemaker Performance (Continued).....</i>	<i>56</i>
<i>Troubleshooting: Score Slitting (Slit Quality).....</i>	<i>56</i>
<i>Score Knife Spare Parts</i>	<i>57</i>
<i>Transmissions</i>	<i>58</i>
<i>Unwind Pedestal Centering</i>	<i>58</i>
<i>V-Belt Tension and Setpoint Adjustment.....</i>	<i>58</i>
<i>Steel and Aluminum Rolls.....</i>	<i>60</i>
<i>Rubber Coated Rolls.....</i>	<i>61</i>
<i>Plasma Coated Rolls.....</i>	<i>62</i>
<i>Nexen Clutches.....</i>	<i>63</i>
<i>Clutch Maintenance Schedule.....</i>	<i>63</i>
<i>Troubleshooting: Clutch Performance</i>	<i>64</i>
<i>Montalvo Brakes.....</i>	<i>65</i>
<i>Brake Maintenance Schedule</i>	<i>65</i>
<i>Troubleshooting: Brake Performance.....</i>	<i>65</i>
LUBRICANTS	66

TABLE OF CONTENTS

<i>Lubricants</i>	66
REVISION HISTORY.....	67

Section

1

INTRODUCTION

This guide is an aid to assist operators, technicians, and mechanics in maintaining Catbridge equipment for optimum equipment performance. This maintenance schedule is intended to be applied to machinery in service for about 3000 hours per year.

Use the maintenance schedule as a guideline only; the specific operating conditions of the equipment (duty cycle, environment, web characteristics, machine speed, etc.) may warrant modification of this schedule to best suit the application. If there is any doubt regarding the following service schedule, contact a Catbridge representative for further instructions. (Service@Catbridge.com)

Whenever machine service or maintenance is performed, the work area must be made safe and secure for all personnel in or near the work area.

ATTENTION!

Before commencing any work on the machine, refer to Section 2 SAFETY of this manual for important safety instructions.

Never allow the machine to fall into a state of disrepair. If any component is found to be defective or missing the machine should be locked out, and the faulty or missing part must be replaced before the machine resumes operations. Machine components must never be altered in any way, or used for any unintended purpose.

It is important to become completely familiar with the *Problem*, *Procedure*, and *Predicable* outcome of efforts. All questions concerning these **3P's** should be addressed with a Catbridge Service representative.

- Read Material Safety Data Sheets (MSDS) and Technical Bulletins for application of all materials and fluids used before performing any machine service.
- Keep work area well ventilated and wear eye protection at all times while performing any of services like cleaning, adjusting, repairing the machine.

- Report to appropriate personnel any unusual sounds, noises, or vibrations coming from machine during normal operation. It could be an indication that there is a problem or service is required.

- Immediately suspend equipment operation until receiving approval to resume production by maintenance supervisor.

Section

2



SAFETY

Understanding Safety Labels

The machine safety labels are placed on various parts of the machine. Machine safety labels are categorized using the words **DANGER**, **WARNING**, or **CAUTION** and are used to alert personnel to possible hazards based their potential outcomes.

This manual also provides a brief explanation of each type of safety label, based on each of the above three categories and the label location. In Section 3 Machine Labels, more detailed information about label location and an image of each label appears in a table format.

Below is an example of one type of illustration for each of these categories and a brief description.

<p><u>DANGER</u></p> <p>If the dangerous situation is not avoided, serious injury or death will result.</p>	
<p><u>WARNING</u></p> <p>If the warning is not heeded, death or serious injury may result. The Operator must follow the follow Lockout/Tagout procedures before continuing.</p>	
<p><u>CAUTION</u></p> <p>If proper precautions are not taken, minor or moderate injury will result.</p>	

Read Instructions

- Read, understand and follow all safety messages and instructions in this manual and on equipment before operating machine.
- If the operator, mechanics or other personnel cannot read English, it is the owner's responsibility to fully explain this material to them.
- Become familiar with the safe operation of the equipment, operator controls, and safety signs.
- Train all operators and mechanics prior to usage. **The machine owner is responsible for training of personnel.**
- Never allow children or untrained people to operate or service the equipment. Be aware of federal or local regulations that may restrict the age of the operator.
- The owner can prevent and is responsible for accidents or injuries occurring to them, other people, or the equipment.
- Novice operators should only operate the equipment under the direction and supervision of an experienced operator.

Safe Machine Operation

- Inspect machine before you operate.
 - Be sure hardware is tight.
 - Repair or replace damaged, worn, or missing parts.
 - Be sure guards and shields are in good condition and properly secured.
 - Make any necessary adjustments before operation.
- Never attempt to modify or alter any component of the machine in any way.
- Never override, disable or tamper with any safety switch or safety device.
- Never operate the machine without all guards, safety switches, and safety devices in place and fully functional.
- Check that operator controls are correctly functioning at each work shift.
- Do not operate the machine if any control device is broken, missing, or disabled. Test safety systems including E-stop emergency switches and cables.
- Only use accessories and replacement parts on this machine that are approved by Catbridge Machinery.
- Stay clear of fast moving webs.

High speed moving webs have the potential to cause serious injury or death.

Always exercise extreme care when operating web converting machinery.

Avoiding Injury and Preventing Accidents

In order to avoid injury and to prevent accidents of any kind, operators and all personnel operating the equipment are required to do the following:

- Visually inspect the area around machine for other personnel prior to running.
- Alert all personnel and bystanders in nearby vicinity of machine prior to running.
- Be alert and focused at all times; operators must continuously be aware of co-workers and personnel who share work area.
- Stop machine when untrained personnel enter the area.
- **Never leave the machine unattended when it is running.**
- **Never operate the machine under the influence of alcohol, controlled substances, or medications, or when feeling ill, tired, or sleep deprived.**

Rotating Shafts

- Do not wear long hair, loose fitting clothing, or jewelry, and exercise extreme caution when working near running machine and rotating shafts.

High speed moving webs have the potential to cause serious injury or death.

Always exercise extreme care when near rotating shafts.

Handling Slitting Knives and Tooling

- The slitting knives and tooling used on this machine are extremely sharp and can easily cut and slice causing serious injury, trauma, or death.

Exercise extreme caution while handling or working near slitting knives and tooling.

Cut proof gloves are required.

- Operate the machine under good lighting conditions only.
 - Wear safety equipment and appropriate clothing for the job at all times while near or operating machinery.
 - Wear a suitable hearing protective device such as earplugs. Loud machine noises can cause impairment or loss of hearing.
 - Always wear safety goggles, or safety glasses with side shields, when operating machine.
 - Wear safety shoes at all times. Keep hands, feet, and tools away from any moving parts to avoid injury.

Safe Maintenance Practices

- Qualified, trained personnel should service this machine only.
- Understand service procedures before performing maintenance or service to the machine.
- Keep all nuts and bolts tight to be sure equipment is in safe working condition.
- Check operation of safety switches, safety devices, and guards for proper operation regularly.
- Keep machine area free of debris, and regularly clean machine of debris build-up.
 - Promptly clean up any liquid spills.
- Never make any adjustments or repairs while the machine is running.
 - Machine movement should completely stop before adjusting, cleaning, or servicing.
- Always use lockout and tag out procedures when adjusting, cleaning, or repairing machine.
- Maintain or replace safety and instruction labels, as necessary.
- Use barriers to identify work zones and to prevent unauthorized personnel from entering work zone.
- Identify work zones with sign(s) describing the work in progress and the supervisor in charge.

Pinch Points, Moving Nip Rolls, and Transmission Drives

- Support any machine component that must be raised for service work securely.
- Avoid working alone when possible.
- Disconnect, lockout, or tag out all power sources to machine before commencing work.
- Release pressure from any components with stored energy, such as pneumatic cylinders or springs, carefully before servicing the machine.
- Install parts using clean, well-maintained service tools.
 - Repair any damage immediately.
 - Replace any worn or broken parts with Catbridge approved replacement parts.
- Hoses and pneumatic lines can fail due to physical damage, kinks, age, and exposure.
- Check and replace damaged hoses and lines regularly.

Exercise extreme caution when working around nip rolls, pinch points, and transmission drives. Moving Nip Rolls, Pinch Points, and Transmission Drives can cause serious injury, trauma, or death by crushing.

Potential High Pressure Sources

- Avoid potential hazard by relieving all pressure prior to working on pressurized systems.

Exercise extreme caution when working on pressurized systems. Pressurized air or hydraulic fluid escaping a ruptured hose or line can penetrate the skin causing serious injury.

High Voltage and Power Sources

- Protect hands and body from high-pressure leaks or electrical power sources with appropriate protective clothing and tools.
- Hoses, lines, and electrical connections can loosen due to physical damage and vibration.
- Check for loose connections on a regular basis.
- Tighten and repair loose connections immediately

Exercise extreme caution when working on electrical systems. High voltages in electrical systems can cause serious injury, trauma, and death. Spark emissions and overheated conductors from electrical systems can cause deadly fires and burns.

Handrails and Walkways

Falling is a major cause of personnel injuries. Keep all platforms and walkways clean and dry. When stepping onto or leaving walkways, use caution when slippery conditions are present. Use handrail.

- Always maintain a three-point contact and watch where you are going; avoid being distracted when stepping onto or leaving a walkway or platform.
- Never jump onto or off a walkway.

Heavy Material Handling

Lifting heavy objects is another major cause of personnel injuries. Heavy product rolls and machine components, such as lift-out shafts, create potential personnel injury risks caused by lifting.

- Do not lift an object if it is too heavy or awkward for good balance.
 - Get assistance or use a mechanical lifting device.
 - Lift with your legs, not your back.
- Never stand underneath any object that must be lifted overhead.
- Always wear hardhats in work areas where overhead lifting is prevalent.

Exercise extreme caution working with overhead lifting devices. Overhead lifting of heavy objects has the potential to cause serious bodily injury or death.

Beyond the scope of this manual, research and follow requirements of third party sources (OSHA, ASME, etc.). Available literature that embodies regional and national codes and specific regulations for your factory equipment and production environment should be considered.









Section

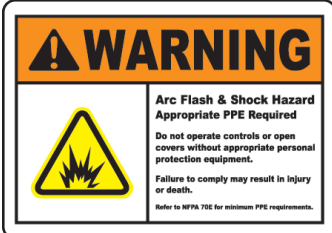



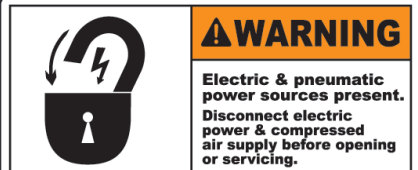

3**MACHINE LABELS**





The following pages contain illustrations of safety labels that may appear on the recently purchased Catbridge machine. A brief explanation appears on the safety label.

Before operating any machinery, become thoroughly familiar with safety procedures of both the equipment (see **Section 2 SAFETY**) and the company.

Only trained personal should operate machinery, observing all safety regulations.

LOCATION	LABEL IMAGE / CONTENTS
Electrical Panels	 <p>WARNING Arc Flash & Shock Hazard Appropriate PPE Required Do not operate controls or open covers without appropriate personal protection equipment. Failure to comply may result in injury or death. <small>Refer to NFPA 70E for minimum PPE requirements.</small></p>
Electrical Panels	 <p>WARNING  High Voltage.</p>
Unwind with Web Guiding Systems	 <p>DANGER  STAY CLEAR. Machine starts automatically.</p>
Air Supply Valve Electrical Panels	 <p>WARNING  Electric & pneumatic power sources present. Disconnect electric power & compressed air supply before opening or servicing.</p>
Main Control Panel	 <p>WARNING  HAZARDOUS VOLTAGE INSIDE Authorized personnel only. Follow LOCKOUT/TAGOUT procedures before servicing.</p>
Slitting Section By Knives	 <p>SHARP EDGES USE EXTREME CAUTION</p>

LOCATION	LABEL IMAGE / CONTENTS
<p>Machine/Transmission Guard Doors</p>	
<p>Inside Transmission Enclosures</p>	
<p>Knife Positioner Guard</p>	
<p>Cut Off Knives (Knife Positioner)</p>	
<p>Lamination Station</p>	
<p>Embossing Section</p>	

LOCATION	LABEL IMAGE / CONTENTS
<p>Core Pointers Unloading System</p>	 <p>CAUTION Laser Radiation. Do not stare into beam. Class II laser product.</p>
<p>Core Pointers Unloading System</p>	 <p>Class II Laser Radiation</p>
<p>Inside Transmission Guards</p>	 <p>Hand Entanglement</p>
<p>Inspection Section Near Roller Nip Guard</p>	 <p>Rotating Rollers</p>
<p>Main or Auxiliary Panel with External Power Source</p>	 <p>WARNING THIS DISCONNECT DOES NOT REMOVE ALL POWER FROM PANEL BRADY. BRADYID.COM</p>

Section

4

MACHINE MAINTENANCE SCHEDULES

In order to operate at optimum capability of your Catbridge machine, the table below represents regularly scheduled maintenance tasks.

FREQUENCY	MAINTENANCE TASKS
Daily	<ol style="list-style-type: none"> 1) Clean all debris away from machine. 2) Inspect all rubber rolls for adhesive, ink, or residue build-up, and promptly remove with-proper cleaner for your specific roll type. 3) Visually inspect machine for damage. 4) Inspect machine to assure all guards are in place and fully functional. 5) Inspect machine for any oil or air leaks and repair if necessary before operating equipment. 6) Check lamps.
Weekly	<ol style="list-style-type: none"> 1) Clean the Web Guide unit and sensor(s) of accumulated debris. 2) Drain air filter of water accumulation if necessary. 3) Inspect all pressure gauges for correct settings. 4) Clean static elimination bars. 5) Re-center unwind pedestals. (see page 58). 6) Perform daily maintenance schedule tasks. 7) Check operation of all E-stops, light curtains, and other safety devices.

FREQUENCY	MAINTENANCE TASKS
<p>Monthly (or 500 Hours)</p>	<ol style="list-style-type: none"> 1) Clean dust accumulation from all motors. 2) Inspect thickness of friction material on clutches/brakes, and replace when necessary. 3) Lubricate grease fittings, open gears, roll pusher lead screw and all linear rail bearings for roll pusher, knife holders, rewind mandrel supports, unwind, and unloader. 4) Lubricate between vertical roll pusher arms and roll pusher plates. 5) Check all transmission belt tensions and tracking for rewind and unwind. 6) Check tendency idler V-belt tension and over-speed. 7) Inspect machine for evidence of loose components or unusual wear, especially around web cut-off and enveloper assemblies. 8) Lubricate all cut-off and enveloper assembly pivots; oil felt wiper on cut-off knife holders, and tabber razor knife. Follow the machine's Lock Out Tag Out Procedure. 9) Lubricate felts in rewind differential shaft(s). Note: In high tension applications, interval is reduced to 200 hours 10) Lubricate rewind mandrel end support slides and mandrel centers. 11) Check fasteners and function of all plungers, machine actuated valves, and lock cams for both turrets, and lubricate turrets' lock pivots. 12) Check layon roll alignment and pressure, and adjust if necessary. 13) Check output of all loadcells on HMI. Load cell output should read 0 +/-2 lbs. without web. Recalibrate all loadcells that are not within proper specifications. 14) Check oil level and hydraulic lines on unwind hydraulic power unit. 15) Lubricate unwind dancer pivot bearings. 16) Perform weekly maintenance tasks.

FREQUENCY	MAINTENANCE TASKS
Semi-Annual (or 3000 Hours)	<ol style="list-style-type: none"> 1) Inspect all electrical motor drive mounting and electrical connections. 2) Clean dust accumulation from electrical motor drives and ventilation areas. 3) Clean or replace electrical cabinet exhaust filter. 4) Check machine level and alignment. 5) Inspect electrical component connections for signs of wear or excessive heat scarring. 6) Perform monthly maintenance tasks.
Annual (or 6000 Hours)	<ol style="list-style-type: none"> 1) Inspect all drive belts for wear and replace if necessary. 2) Inspect synthetic roll surfaces and resurface if necessary. 3) Perform bi-annual maintenance tasks. 4) Replace felts in rewind differential shaft(s). 5) Inspect bladders on differential shaft(s). 6) Check leveling and securing of the machine, adjust and correct if necessary.

Section

5

CALIBRATION PROCEDURES

Loadcells

The loadcells measure the tension of the web as it is wrapped around the roll to which it is attached. In order to accurately measure the tension of the web, the loadcells and corresponding amplifier must be correctly calibrated.



Positioning

Position the loadcells according to the bisector of the wrap angle on the roll it is on and follow the markings on the each load cell.

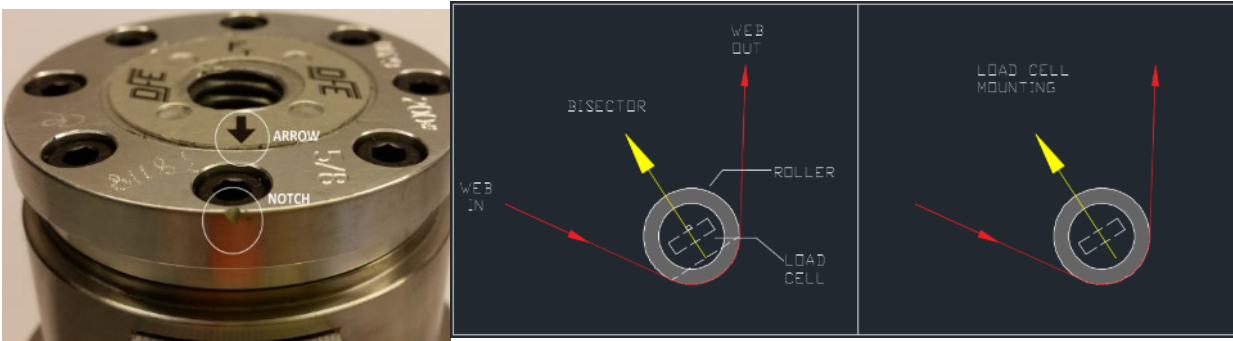

NOTE: There is notch and label on each load cell. This is one of the most critical parts of measuring the load as the force exerted by the web will be in this direction.

Amplifier

Calibrate the amplifier first by performing the following steps.

- 1) Access the amplifier and set the jumper 10% or 25% calibration (depending on the application).

NOTE: This jumper was set when the machine was commissioned. It only needs to be changed when the amplifier is being replaced.

- 2) Ensure the loadcells are clear of obstructions and are not under any stress. Remove the web for best results. Make sure there is NO tension on any part of the loadcell being calibrated.
- 3) Press and hold the **Press to Zero** button until the **green** LED on the circuit board of the amplifier blinks.
- 4) Identify the loadcell capacity (100 lbs., 200 lbs., etc.) and select the appropriate weights (e.g. if the loadcells are 200 lbs. rated, 20 lbs. is hung for 10% jumper).
- 5) Identify the web path as per manual or the PanelView. Hang weight to place the load on the loadcells as shown in diagram below using non-stretching narrow strap. (Rope can be used but is not recommended when dual durometer rolls are present).

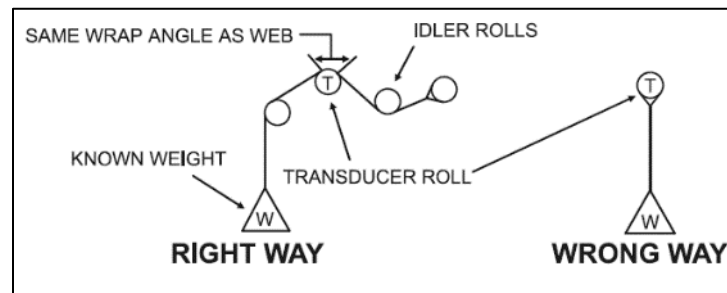

- 6) Press and hold the **Push to Calibrate** button until the **green** LED on the amplifier's circuit board blinks, indicating that calibration is complete.
- 7) Return the cover to the amplifier.

NOTE: For more information about the amplifier, please view the Dover Flexo TI18C Instructional Manual.

HMI

Once the amplifier is properly calibrated, the PLC must now be calibrated to process the signal.

This procedure requires authorized access to the Maintenance Screens.

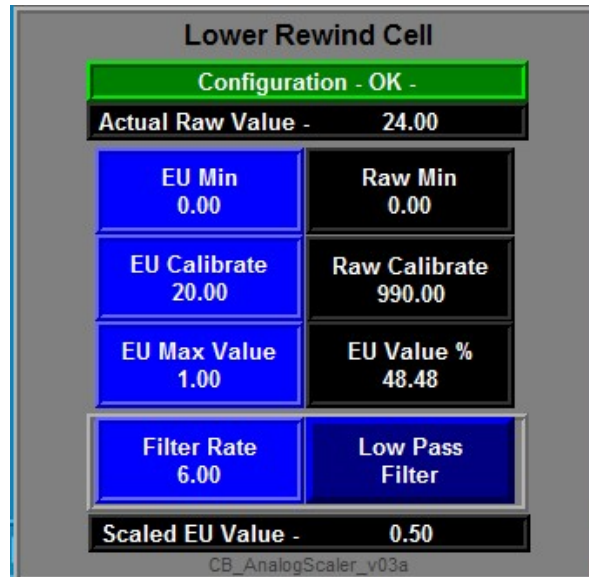

To calibrate the HMI, perform the following steps:

- 1) Ensure the loadcells are clear of obstructions and not under any stress.
- 2) On the Load Cell Maintenance Screen, push EU Zero button, this opens a numeric keypad.
- 3) Enter the zero value for calibration (usually 0 or 1 depending on application).
- 4) Hang the same weight used in the amplifier section.
- 5) On the Load Cell Maintenance Screen, push **EU Calib** button, this opens a numeric keypad.
- 6) Enter the value of the weight for calibration (e.g. if 20 lbs. was hung, 20 would be entered).

NOTE: For reference, the **EU Span** value shown on some machines is used when a percentage output from the analog device is required. The value should not be changed unless specifically directed by Catbridge Service

- 7) Select the mode to run by pressing the dark **blue** button to cycle through the different modes. (For loadcells, **LP Filter** is a default setting.)

Low Pass Filter – Default value is 2.

- Limits frequency of actual raw value (analog input) changes.
- Limits how often actual raw value (analog input) is used in calculations.
- Limits input noise and is used mostly for loadcell feedback.

Rate Limiter – Diameter calculation default value is 2.

- Limits how the actual raw value (analog input) changes over time.

No Filter – Actual raw value from analog input card is used in calculations 0

- 8) If using the **Low Pass Filter** mode, set the **Low Pass Filter** value as desired by pushing **Filter Rate** and entering the filtering value (**NOTE: For most applications, 2.0 is acceptable**).

NOTE: If the analog card on the PLC displays a red LED, the calibration routine is more than likely measuring a negative voltage and must be re-calibrated.

- **Low pass Filter** - limits frequency of actual raw value (analog input) changes.
 - Limits how often actual raw value (analog input) is used in calculations. This function limits input noise and is used mostly for load cell feedback. Default value is 2.
- **Rate Limiter** –limits how actual raw value (analog input) changes over time. For diameter calculations default value is 2.
- **No Filter** – actual raw value from analog input card is used in calculations

Adjusting variable pitch pulley

NOTE: Use extreme caution when performing this procedure and follow Lock Out/Tag Out procedures when making adjustments.

- 1) Remove the web from the machine.
- 2) Access the Line Run Setup Screen from the Maintenance Menu. **This step requires Engineer or Maintenance Level Access.**
- 3) Enable Speed Match and Rewind Fixed Diameter or set material thickness to zero (not available for all machines) and core diameter correctly.

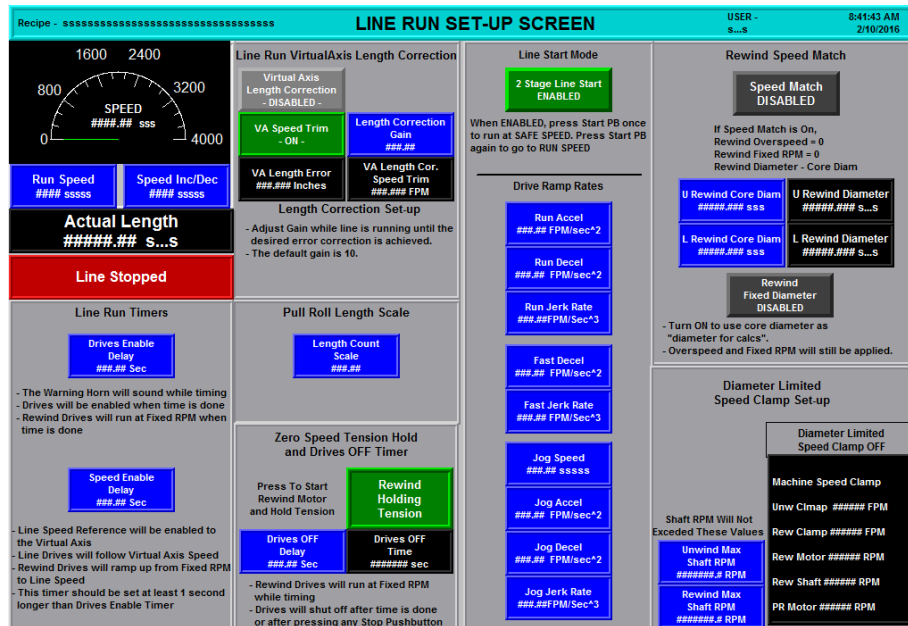

- 4) It may be necessary to increase core diameter if 3" rewind shaft is installed.
- 5) Start the machine and set it to 25% of maximum speed. If no issues are found, increase speed in increments: 50%, 75%, then 100%
- 6) Once the machine reaches the defined speed, measure the speed of the main pull roll
 - i. It should be within 0.5% of set speed.
 - ii. If not, contact Catbridge Service Department.
- 7) Measure the speed of the roll being adjusted

- i. It should be 1% faster than pull roll. (For example, if PR 2000 fpm, then exit roll's speed should be just under 2020.)
- 8) If an adjustment to the speed of the roll is required, an adjustment to the pulley is also needed.
- 9) Stop the machine and follow **Lock Out / Tag Out Procedures**.
- 10) Access the transmission enclosure.
- 11) Remove or loosen V-belt driving exit roll.
- 12) Loosen the four set-screws (see the picture below).

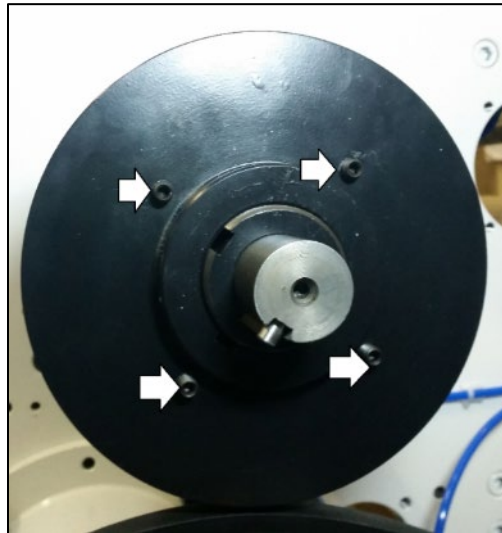

- If shaft is spinning too fast, turn the outside half of the pulley (sheave) clockwise (CW) in order to make it narrower
 - If the shaft is spinning too slow, turn the outside half of the pulley (sheave) counter clock wise (CCW) in order to make it wider
- 13) Tighten the four set-screws, reinstall the V-belt and set the belt tension.
 - 14) Restart the machine and measure the surface speed of the shaft. It may be necessary to perform the above steps multiple times until desired over speed of the shaft is set.
 - 15) When all adjustments are complete and acceptable, return the core speed to normal.
 - 16) Disable Speed Match and Rewind Fixed Diameter.

6

LEVELING AND ALIGNMENT

Leveling and Securing

Machine should be mounted on minimum 4inches (100mm) thick concrete floor. Some heavier machines may require thicker floor.

The machine can be leveled by using a precision machinist level, such as a Starret number 97. Level to within .005" (inch) per foot accuracy.

On machines with solid side frames.

- 1) Place the machinist level on side pins as shown in picture below. Adjust foot pad jack screws on each corner to of the machine until the machine is level front to back.



- 2) Place the machinist level on a rear roll and on a front roll, using rolls that are at the furthest distance from one another. It is also preferable to use rolls that are resting in bearings that are bore mounted between the side frames. Pull rolls and idler rolls are good examples. Do not place the machinist level on brackets, load cells, rewind mandrels or spreader rolls.
- 3) Adjust the foot pad screws on each corner on the front and rear machine until machine level side to side. Recheck leveling as per step 1.
- 4) Once machine is level from side to side and front to back, tighten jam nuts on each jack screw.
- 5) Follow the same procedure on next sections of the machine.

Machines with separate unwind stands must be positioned so that they are inline/parallel to other sections of the machine. Unwind stands equipped with the bag edge adjustment (skew roll) should be adjusted the same way as other machine sections. Neutral position of the skew roll should be determined after the complete unwind is aligned.

On the shaft-less unwind stands; the same guidelines/procedure applies, with exception that the core chucks are used as points of reference.

Touch Roll Alignment (Catbridge 900)

After the machine was installed, leveled, and aligned, it is required to verify if touch rolls are parallel to rewind shafts.

Following procedure applies to all Model 900 machines.

Required equipment/tools:

1. Good full length core
2. Hex keys
3. Filler gauge

Procedure

1. Install a full length core or at least as long as the touch roll.
2. Lower touch roll with leaving small gap between core and touch roll. Gap should big enough to be able to measure gap at both ends of touch roll.
3. Gap variation between ends should not be more than 0.004" (0.1mm)
4. Don't adjust following two bolts

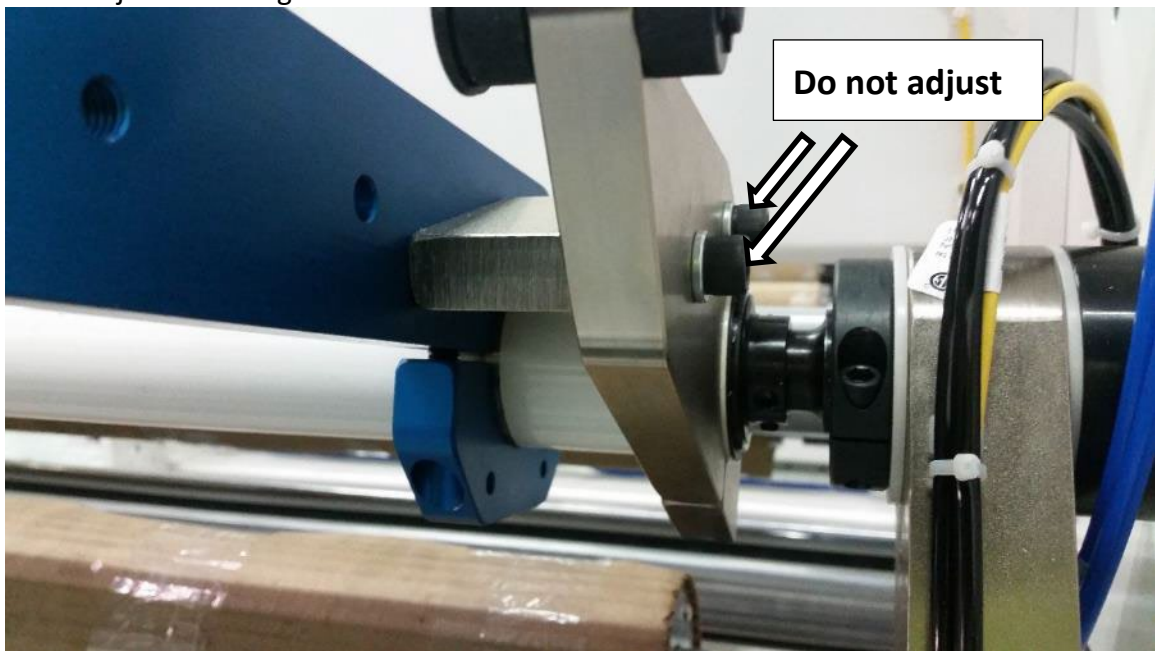

5. Loosen two bolt as seen the picture below

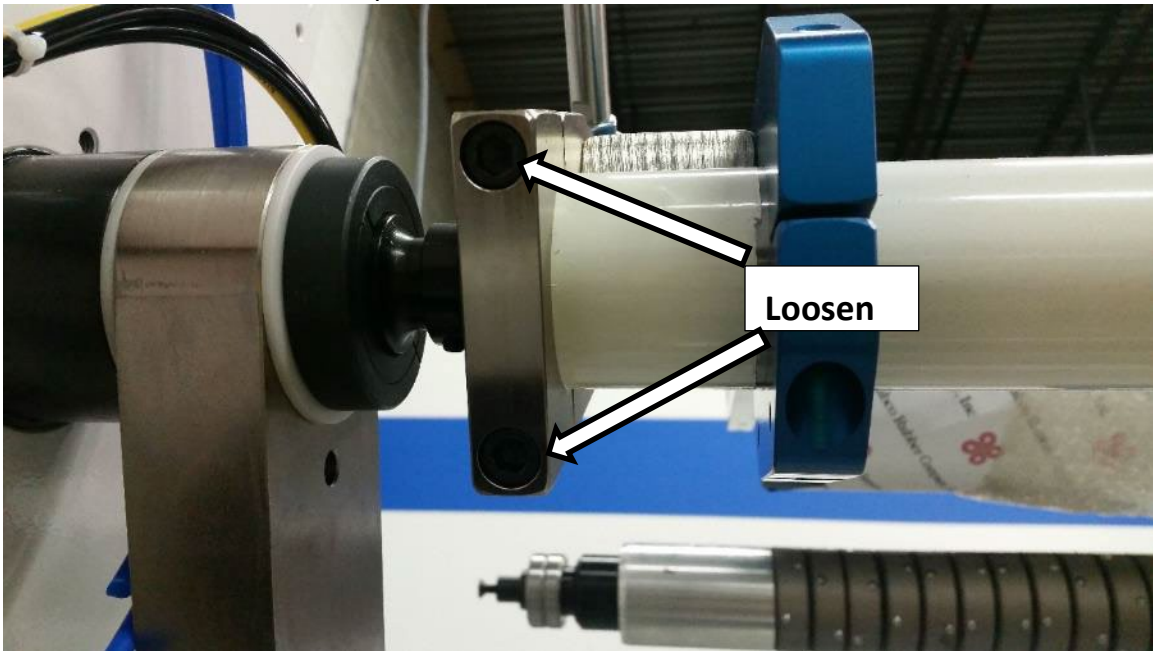

6. To adjust gap between touch roll and core:
 - a. To increase gap – loosen A and tighten B
 - b. To decrease gap – tighten A and loosen B

NOTE: Both bolts don't need much adjustment for touch roll to move

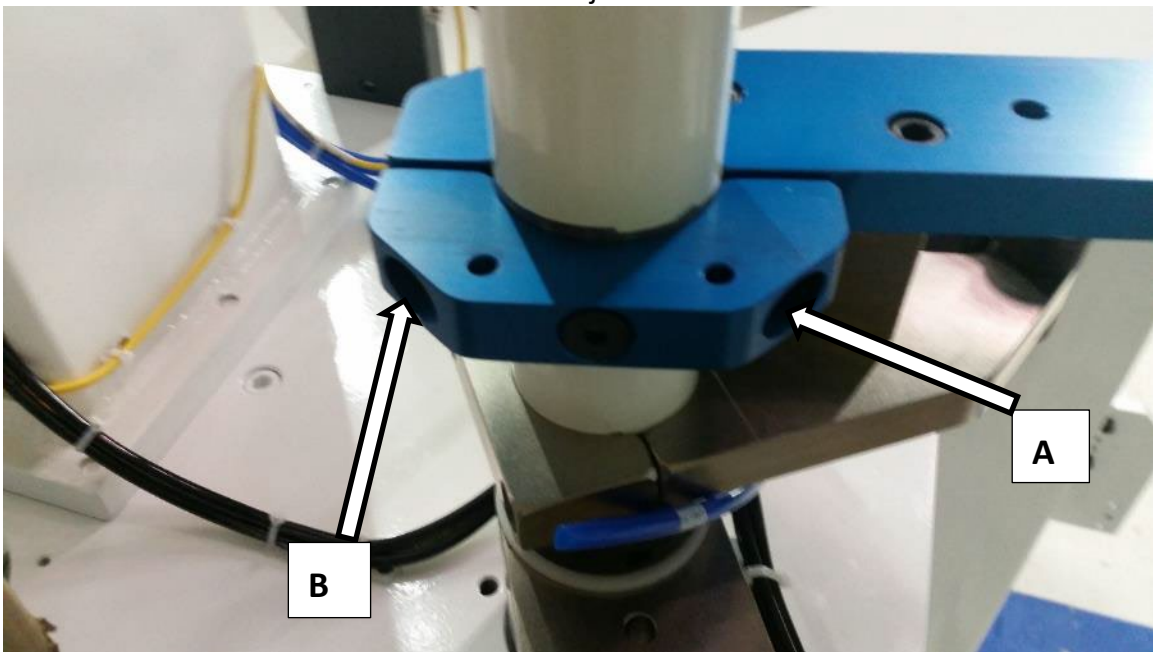

Touch Roll Alignment (Catbridge 901/902/344)

After the machine was installed, leveled, and aligned, it is required to verify if touch rolls are parallel to rewind shafts.

Following procedure applies to all Model 901/902/344 machines.

Required equipment/tools:

1. Good full length core
2. Wrenches
3. Filler gauge

Procedure

1. Install a full length core or at least as long as the touch roll.
2. Lower touch roll with leaving small gap between core and touch roll. Gap should big enough to be able to measure gap at both ends of touch roll.
3. Gap variation between ends should not be more than 0.004" (0.1mm)
4. Adjustment can be made by adjusting two turnbuckles located on each side of the machine's touch roll assembly.

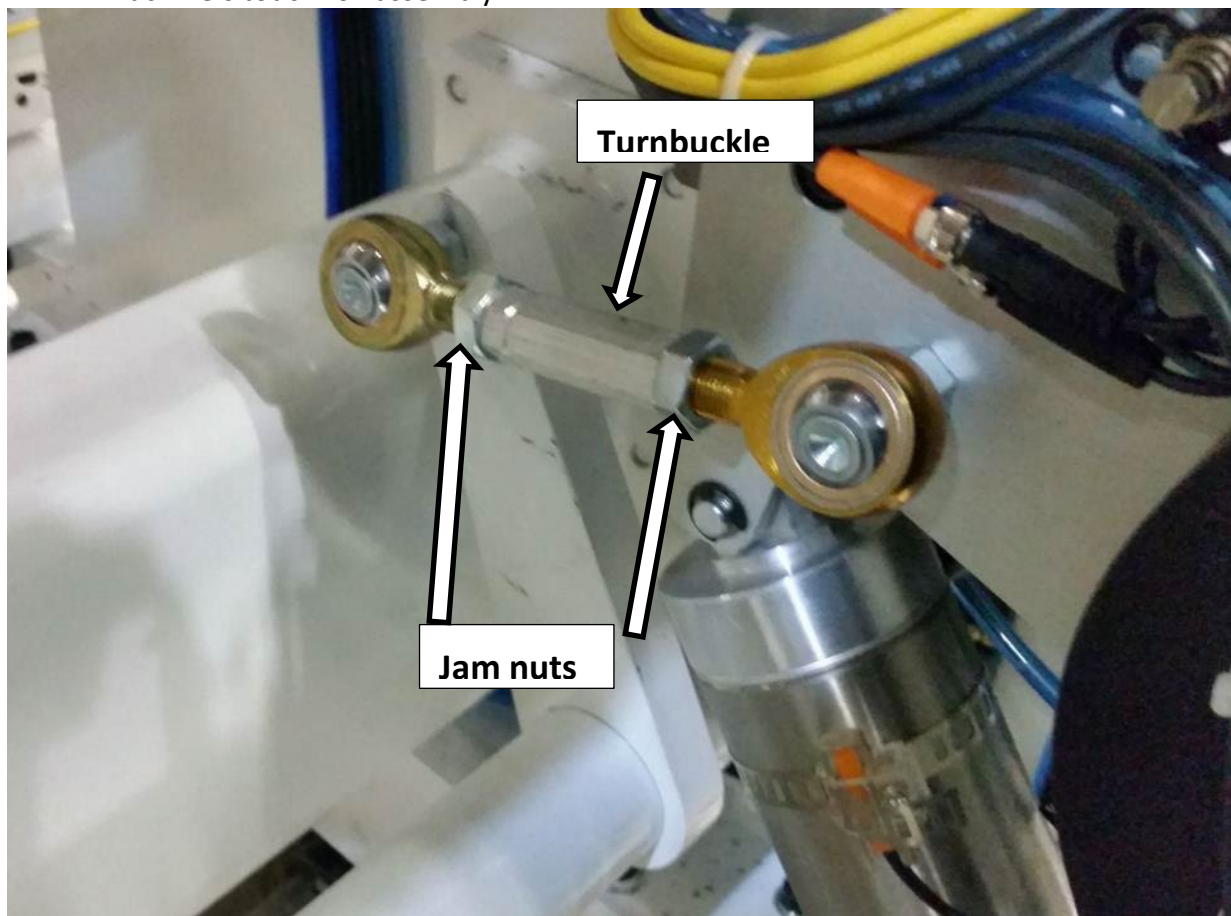

Rewind Shaft Alignment (Catbridge 729)

After the machine was installed, leveled, and aligned, it is required to verify if rewind shafts are parallel to score roll.

Following procedure applies to all Model 729 machines.

Required equipment/tools:

1. Good full length core
2. Wrenches
3. Filler gauge

Procedure

1. Install a full length core.
2. Engage shaft supports and lower rewind arms leaving small gap between core and score roll. Gap should big enough to be able to measure gap at both ends of touch roll.
3. Gap variation between ends should not be more than 0.004" (0.1mm)
Adjustment can be made by adjusting support arms on transmission side of the machine.
4. There three clamps that attach each arm to each pivot shaft. Two outside and one inside of transmission guard.

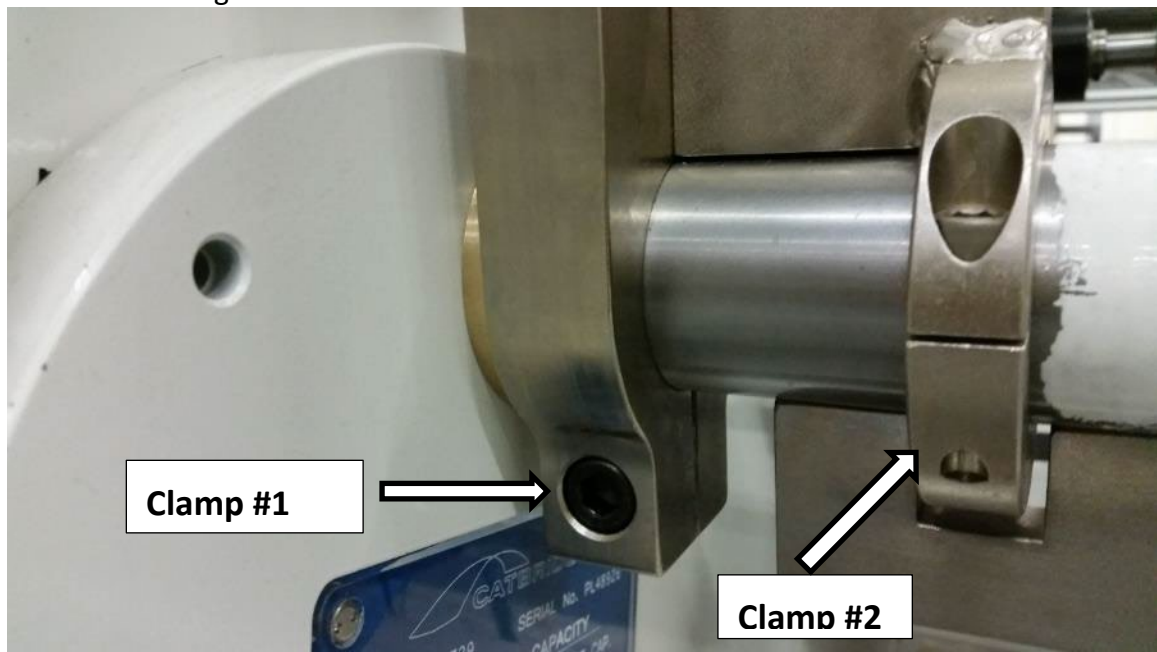

Front Arm

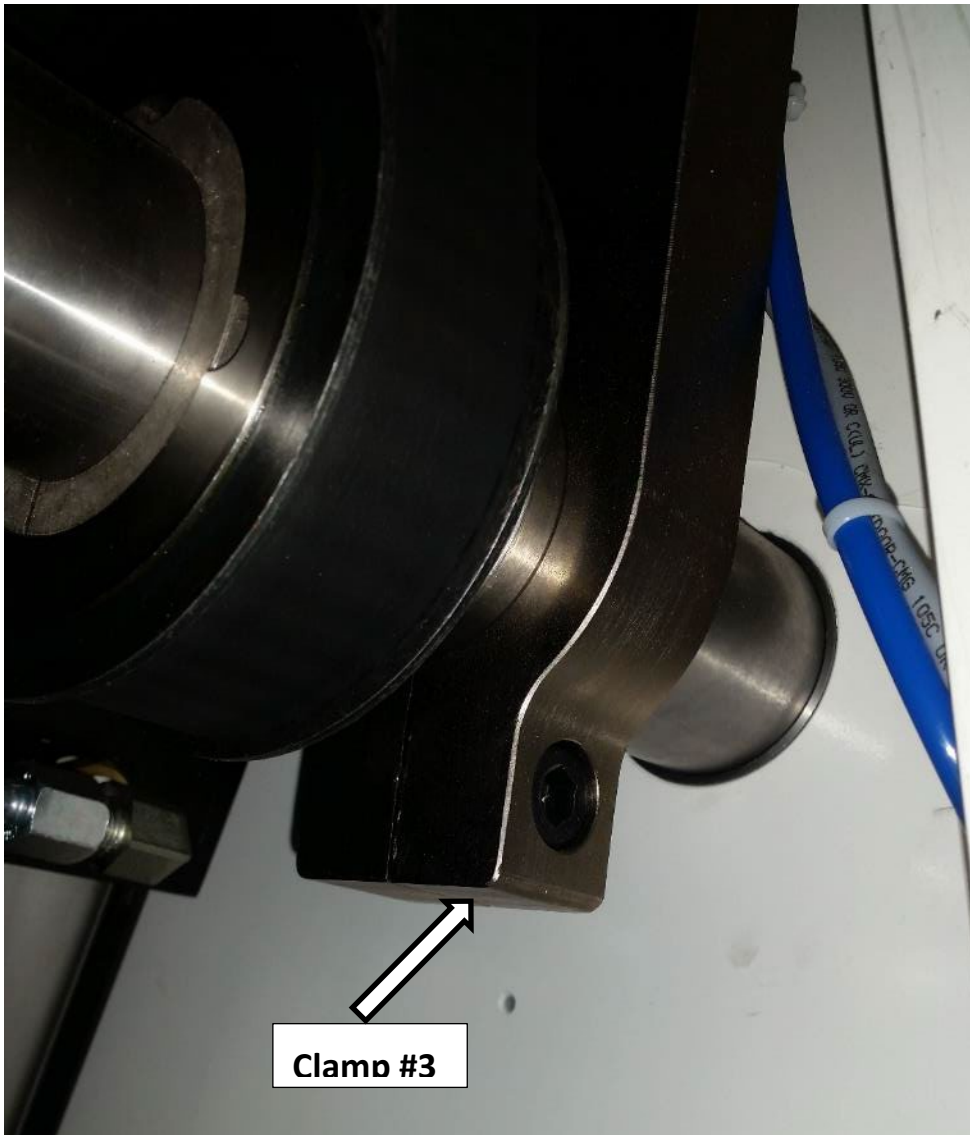

Rear Arm

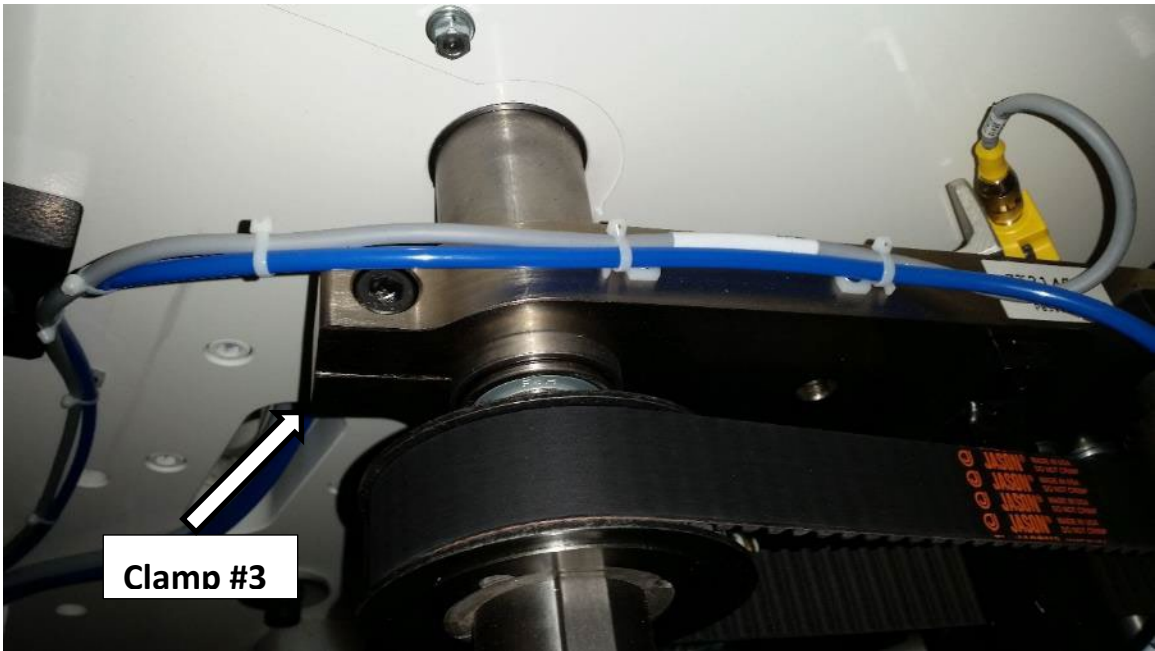

Rewind Shaft Photo-eye Alignment (Catbridge 729)

After the machine aligned, it is required to verify if rewind shaft photoeyes are parallel and correctly positioned.

Following procedure applies to all Model 729 machines.

Required equipment/tools:

1. Wrenches
2. Measuring tape or ruler

Procedure

1. Install a full length core.
2. Engage shaft supports and lower rewind arms leaving small gap between core and score roll. Gap should big enough to be able to measure gap at both ends of touch roll.
3. Gap variation between ends should not be more than 0.004" (0.1mm)
Adjustment can be made by adjusting support arms on transmission side of the machine.
4. There three clamps that attach each arm to each pivot shaft. Two outside and one inside of transmission guard.

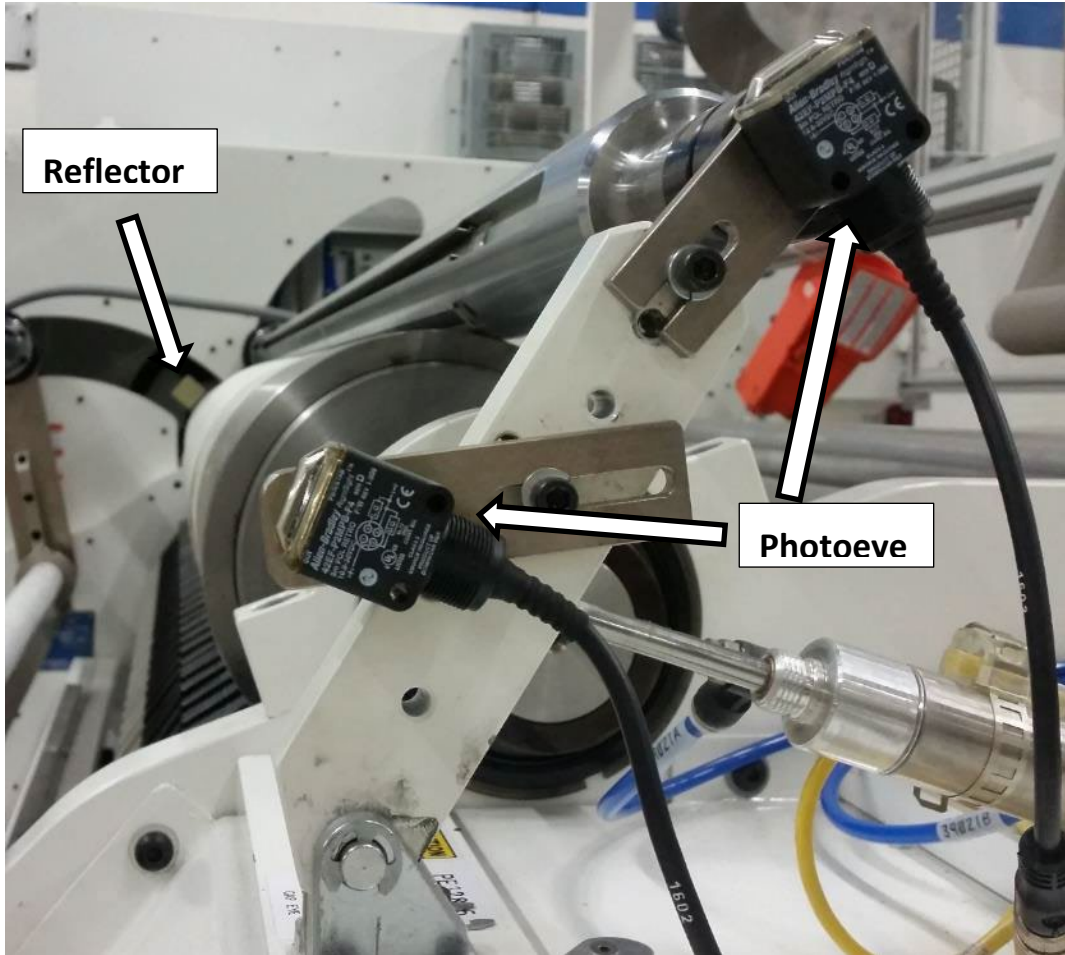

5.

Rewind Shaft Gap mode sensor adjustment (Catbridge 729)

After the machine was aligned and/or air cylinders or proximity switches were replaced, it is required to verify if proximity switches are correctly positioned on the air cylinders. These cylinders are located inside of the transmission guard and at the end of hydraulic cylinders.

Following procedure applies to all Model 729 machines.

1. Upper/lower surface extend proximity switch should be mounted about 1 inch from the lower end cap, as seen in the picture below.



2. Upper/lower surface retract proximity switch should be mounted about 2.5 inches from the lower end cap, as seen the picture below. This alignment is critical to the operation of the machine in either gap or surface winding modes.



3. If the arm starts to move out immediately when the machine is started the sensors may be swapped.

Section

7

MECHANICAL SUBSYSTEMS AND MAINTENANCE**General Lubrication Tips**

Many bearings in the machine are the maintenance free and require no routine lubrication for the life of the bearing. Catbridge flange-style, pillow block, and many linear bearings have 'Zerk or Alemite type grease fittings, requiring routine lubrication service.

Prior to lubricating the bearings, be sure to clean the grease fittings during recommended maintenance intervals. Lubricate the bearings with high-quality long-life moisture displacing EP grease. Select a lubricant to operate over a wide temperature range (minimum 0°-250°F). Do not overload lubricant as excessive grease will damage and deform bearing seals. Apply this grease to open-face gears and gear-racks also.

NOTE: Do not use grease for low friction roller applications; use low viscosity oil to lubricate low friction roller bearings.

Replenish the hydraulic power unit with non-detergent ISO 32 hydraulic oil and the Dodge Tigear Gearboxes with ISO 460 synthetic gear oil. **Lubricants required for FDA applications are not addressed in this manual.**

Please consult Catbridge Machinery Service Department when FDA compliancy is required. **Section 9 ASSEMBLY PARTS AND LUBRICANTS** contains a list of applications and suggested lubricants.

Maintenance Schedules

The tables that appear on the following pages represent recommended scheduled maintenance for various subassemblies. Proper maintenance plays a vital part in the production results of the machine. Remember to perform regularly scheduled maintenance in order to avoid lost time and the production of a poor quality product. For replacement parts for any machine subassemblies, refer to the Bill of Material document that accompanied your machine at the time of purchase. To order replacement parts, contact the Catbridge Parts Department at Parts@Catbridge.com.

Differential Mandrel (Shaft) - Camlock Style

Clean the differential rewind mandrels when dust, debris, or any coatings are present on the mandrel surfaces.

Felt

It is recommended that felt be lubricated every 500 hours of machine run time with food grade lubricant (page 14). Apply, with care, a layer of lubricant (about 3 mm wide) along the length of the strip. Reassemble the roll locks only once the felt has completely absorbed the grease. Felt should be replaced when damaged or every 12 months if under constant and regular usage.

In case of high tension applications, it is necessary to lubricate felt every 200 hours.

NOTE: Do not exceed the recommended quantity of grease because it could escape out of the roll locks surfaces and contaminate the wound material.

Central Steel-Chrome Plated Body Shaft

It is recommended to apply lubricant to the central steel-chromed body shaft every 500 hours of work with food grade dry film lubricant (page 15).

Bladders

The air bladders are also subject to wear and tear causing air leaks. Since this damage is not visible, it is suggested keep in stock spare air bladders already cut to measure and complete with their brass nipple and the rubber seal.

Keep the following in mind:

- Do not use excessive solvent to clean differential rewind mandrels. (Excessive solvent flow will dilute and drain internal lubrication.)
- Do not use cleaning solvents that can harm internal polyurethane bladder material.
- Do not use sharp tools to clean the mandrels. (Sharp tools can damage the shafts, impacting their performance.)

Stay Clear of Rotating Shafts

NOTE: Do not wear long hair, loose clothing, or jewelry, and exercise extreme caution when working near running machine and rotating shafts.

Rotating rolls and shafts can cause serious injury or death.

Direct Friction Differential Mandrel (Shaft)

Clean the differential rewind mandrels when dust, debris, or any coatings are present on the mandrel surfaces.

Bladders

The air bladders are also subject to wear and tear causing air leaks. It is recommended to inspect bladders annually and repair as per manufacture's guidelines.

Keep the following in mind:

- Do not use excessive solvent to clean differential rewind mandrels.
- Do not use cleaning solvents that can harm internal polyurethane bladder material like isopropanol, acetone, benzene, butanol,
- Do not use sharp tools to clean the mandrels. (Sharp tools can damage the shafts, and plastic differential elements, impacting their performance.)

Stay Clear of Rotating Shafts

NOTE: Do not wear long hair, loose clothing, or jewelry, and exercise extreme caution when working near running machine and rotating shafts.

Rotating rolls and shafts can cause serious injury or death.

Lock Core Mandrel (Shaft) -

Clean the rewind mandrels when dust, debris, or any coatings are present on the mandrel surfaces.

Bladders

The air bladders are also subject to wear and tear causing air leaks. It is recommended to inspect bladders annually and repair as per manufacture's guidelines.

Keep the following in mind:

- Do not use excessive solvent to clean differential rewind mandrels.
- Do not use cleaning solvents that can harm internal polyurethane bladder material like isopropanol, acetone, benzene, butanol,
- Do not use sharp tools to clean the mandrels. (Sharp tools can damage the shafts, and plastic impacting their performance.)

Stay Clear of Rotating Shafts

NOTE: Do not wear long hair, loose clothing, or jewelry, and exercise extreme caution when working near running machine and rotating shafts.

Rotating rolls and shafts can cause serious injury or death.

Knives

Clean the knife assemblies when dust, debris, or any coatings are present.

Stay Clear of Knives

NOTE: Exercise extreme care when handling or working near slitting knives and tooling. Use of cut proof gloves is required.

The slitting knives and tooling used on this machine are extremely sharp and can easily cut and slice, causing serious injury, trauma, or death.

Shear Blade Replacement (Catbridge Crosscut Knife)

The crosscut knife utilizes shear slitting. Shear cut slitting uses two rotary knives to produce the same cutting effect as obtained by using a pair of scissors. Scissors present a condition with two sharp blade edges crossing at an angle. To cut the material it is necessary to apply force on the handle of the scissors. The cutting takes place at the junction of the two sharp edges, and as the scissors close, the angle of the junction gets smaller. As the angle changes, the cutting effect changes.

The larger knife is fixed to the drive gear while the small knife is floating on a spring-loaded hub. A circular coil spring is located behind the smaller knife to maintain a constant force between both knives.

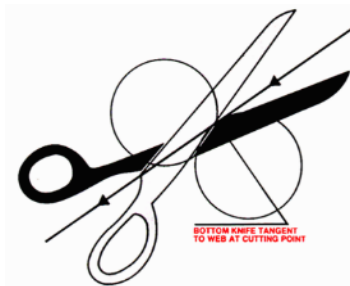

The shear blade replacement may be facilitated by removing of the shear knife holder from the knife cutting assembly. The knife holder is secured to the knife cutting assembly with four socket cap screws.

Both knives are secured with a snap ring. In addition, the larger knife is secured to a gear with three flat head screws. Beneath the smaller knife is a circular coil spring.

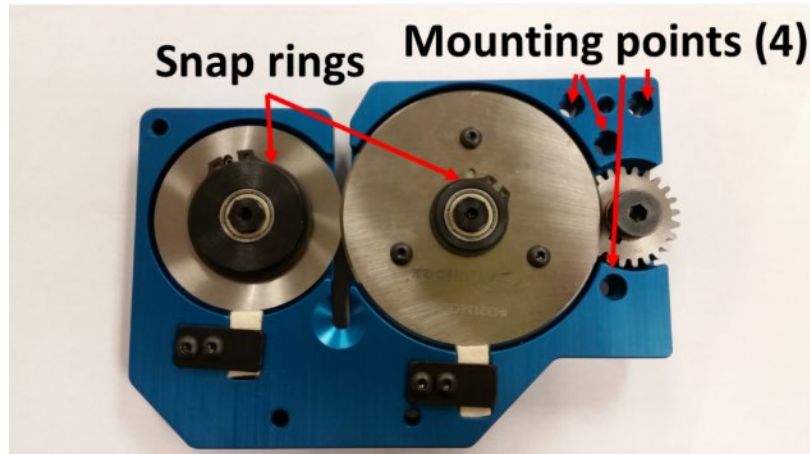

An automatic shear-knife cut-off assembly is shown mounted in turret winder.

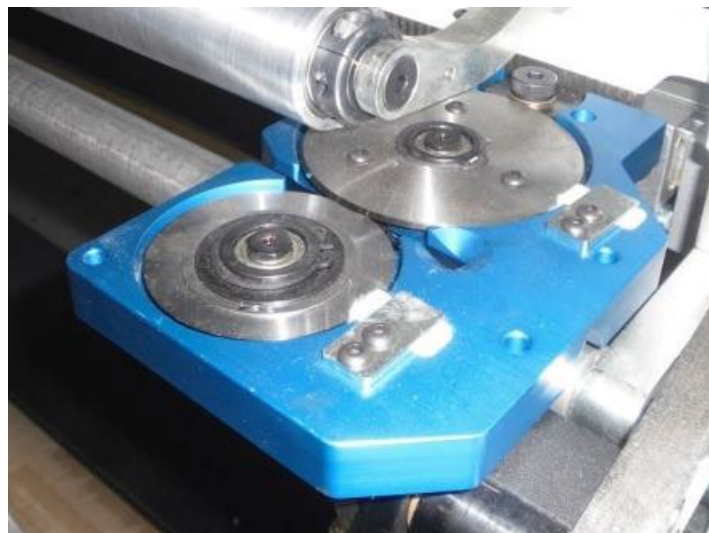

The directions to reassemble the knife holder are listed below.

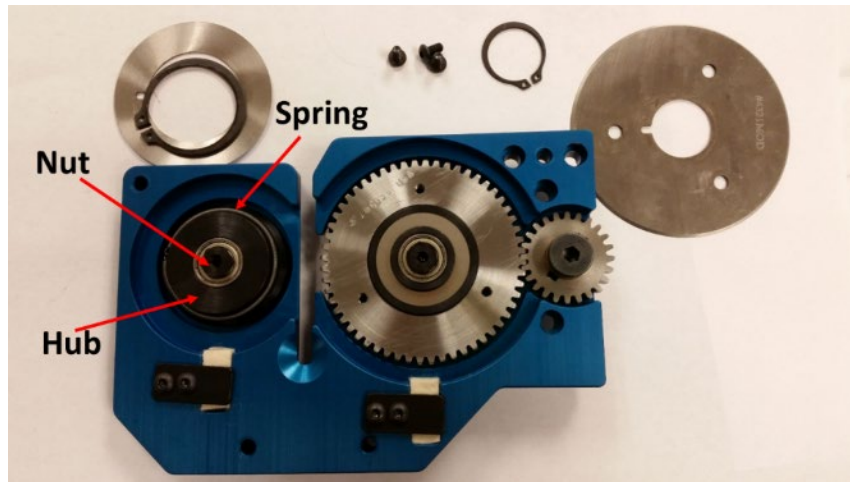

1. The hub is removed from the assembly by taking off the nut.
2. Remove spring from the hub. The knife can be fitted on the hub.
3. Install snap ring.
4. Install circular coil spring in the groove between the hub and the knife.

NOTE: The purpose of the spring is to maintain pressure between larger knife and floating small knife.

5. Install the hub. Thread locker should be used, such as Loctite or Threadlocker Blue 242. Be sure the hub can spin freely and is not binding.
6. Install the larger knife and reinstall the snap ring.
7. Re-install the three flat head screws.
8. Put few drop of mineral oil on the wicks. Replace if necessary.

Shear Blade Replacement (Tidland)

1. Press and hold the blade lock pin and rotate the blade hub until it stops.
2. Loosen the three blade clamp screws.
3. Rotate the blade clamp counterclockwise and slide it off the blade hub when the clearance holes are aligned with the blade clamp screw heads.
4. Remove the knife blade.

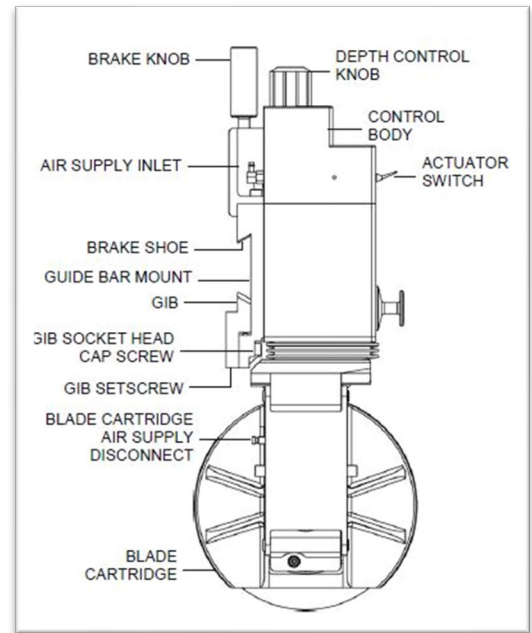
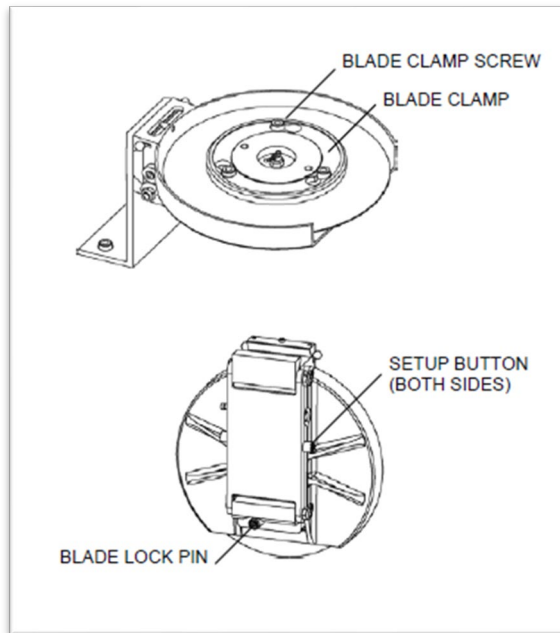

5. Shear knife replacement is opposite to removal procedures. Apply a few drops of mineral oil to each felt applicator pad; do not saturate pads.

Cant Key Instalation (Tidland)

1. Make sure the correct cant key is installed on the knifeholder.

Cant key label colors:

- Red for 'A' web path
- Blue for 'B' web path

2. Make sure the arrow on the cant key points in the same direction as the arrow on the blade cartridge.
3. To remove the cant key, pull the cant key straight out of the knifeholder control body. Push the cant key straight into the knifeholder body to replace.

- Web moves from control side of knifeholder toward the guide bar mount.
- Cant key label is RED.
- Cant key arrow points toward the THIN side of the cant key.
- Blade cartridge arrow points to the nip point (contact side of anvil ring.)

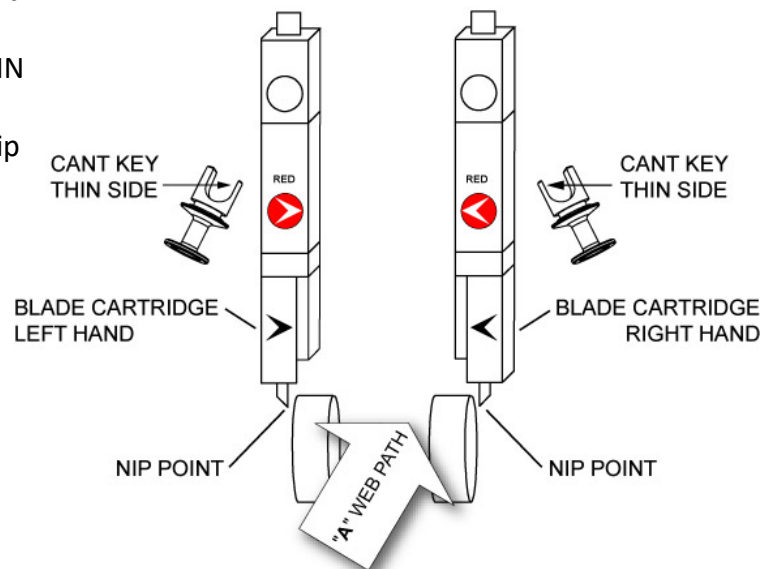

Web moves from the guide bar mount toward the control side of knifeholder.

- Cant key label is BLUE.
- Cant key arrow points toward the THICK side of the cant key.
- Blade cartridge arrow points to the nip point (contact side of anvil ring.)

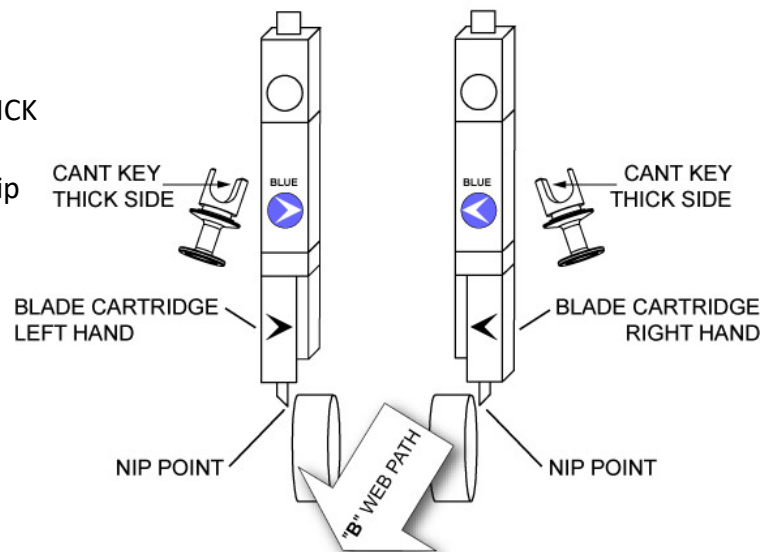

Anvil (female) Knife Replacement - shear shaft (Catbridge)

Before starting, it is necessary to follow Lock OUT Tag Out procedures.

1. Support shear shaft with crane.



2. Remove/loosen two set screws

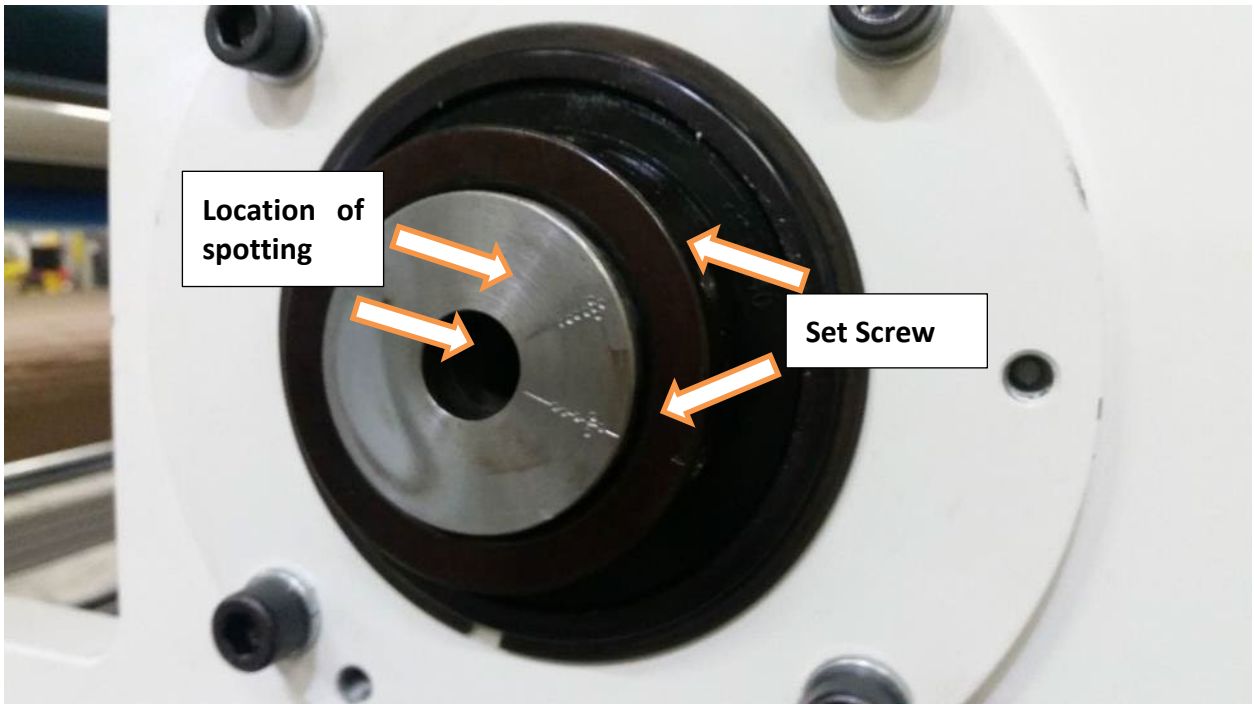

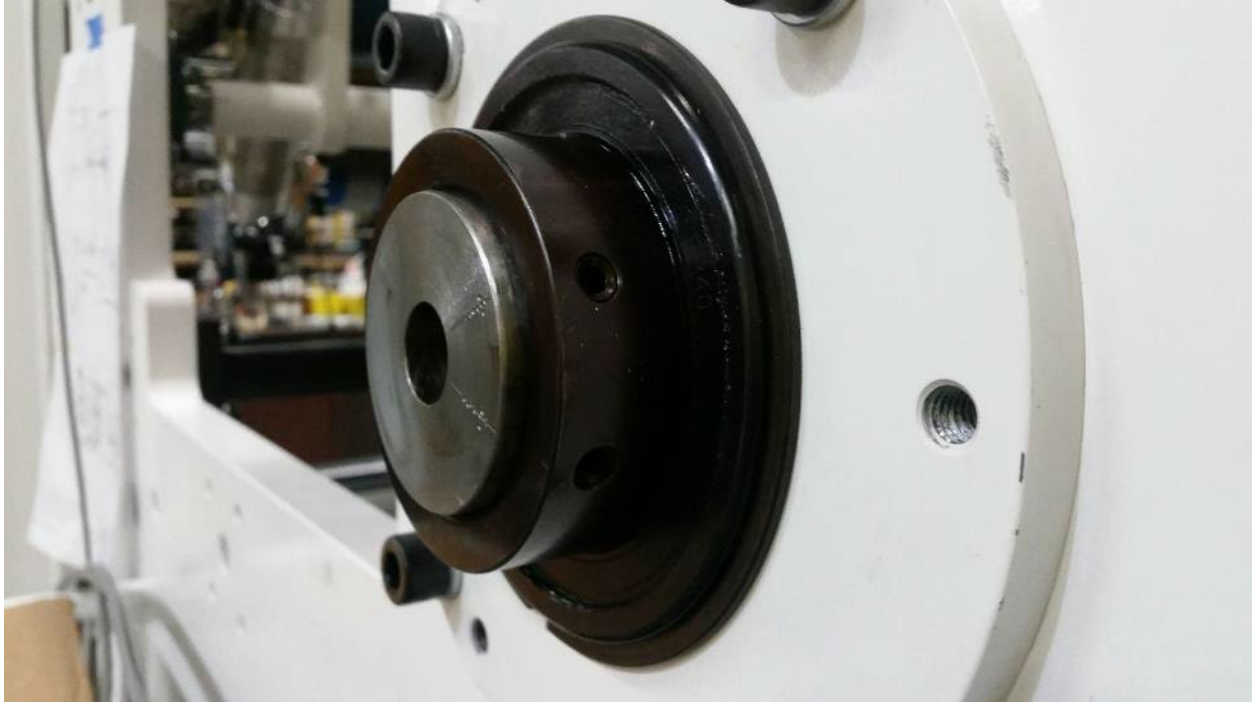

3. Remove four bolts holding hub to the side frame

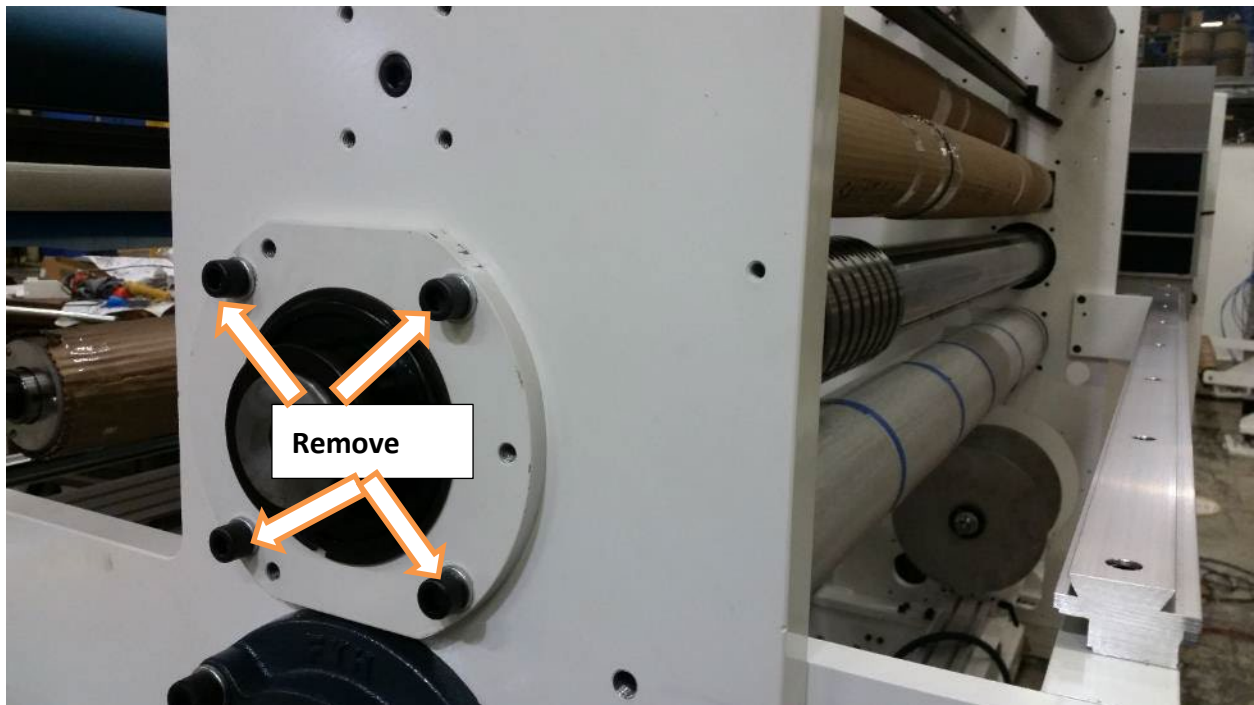

4. Install three 3/8 bolts(jack screws) with at least two inches of thread.

5. Evenly turn jack screw screws until hub is removed from side frame and exposing the opening allowing remove of the female (anvil) knives.

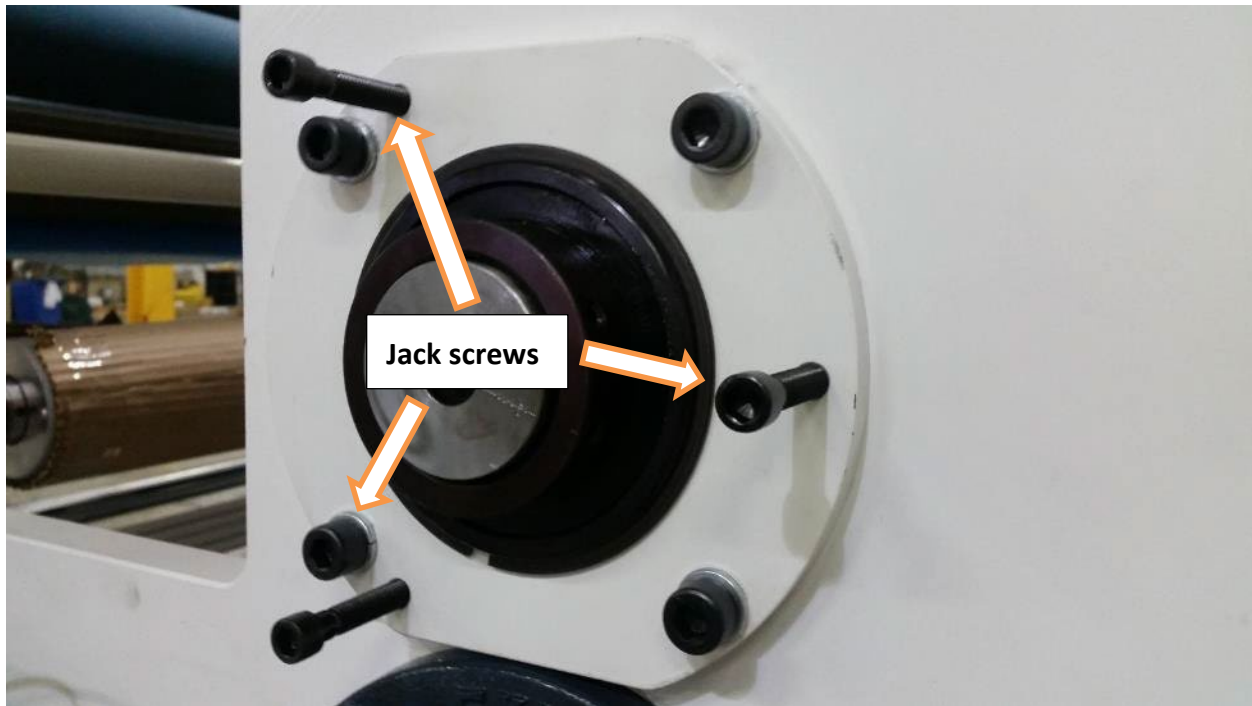

6. Before reinstalling new knives, it is necessary to degauss / demagnetize each knife. Small amount of magnetism will cause knives to stick to each other during automatic knife placement.

Shear Knives Maintenance Schedule

Shear Knife	
Preventive	<ul style="list-style-type: none"> • Keep anvil rings and knifeholder blades clean and balanced. • Do not use oil lubricants in knifeholder. Oil lubricants may cause the knifeholder to function improperly. Use only those lubricants recommended by knife manufacturer.
Daily	<ul style="list-style-type: none"> • Keep all knifeholders clean of debris. • Check air pressure to the knifeholders: Clean, dry, non-lubricated air is essential for optimal knifeholder performance. • Check for air leaks at the knifeholder and manifold. <p>NOTE: DO NOT IMMERSE knifeholders in solvents. Wipe the outer surfaces with a clean, dry rag.</p>
Weekly	<ul style="list-style-type: none"> • Check knifeholder air pressure. Knifeholder air pressure requirements: 1½ cfm @ 60-90 psi (4.1-6.2 bar). • Blow down the blade cartridge to remove dust build up. • Check hose connections to the knifeholders for leaks or cracks. • Inspect control body dovetail assembly o-rings. Replace if damaged or missing. • Check blade cartridge half stroke function.
Monthly	<ul style="list-style-type: none"> • Check adjustment of gib to the guide bar for minimal clearance between knifeholder mount and guide bar. • Clean all surfaces of the control body and blade cartridge. • Inspect bellows for tears around dovetail mount. Replace if necessary
Bi-Yearly	<ul style="list-style-type: none"> • Clean and inspect blade cartridge bearings for looseness. • Remove depth control knob and inspect for dust build up, if applicable. • Remove cant key and inspect for excessive wear and/or damaged o-ring. Replace if necessary with same type of parts. • Check key rubber seal for damage. Replace if necessary.

Troubleshooting: Knifeholder Performance

Problem	Possible Cause	Recommended Solution
Sluggish Knifeholder Action (extension or retraction)	<ul style="list-style-type: none"> • Low air pressure 	<ul style="list-style-type: none"> • Minimum 50 psi required
	<ul style="list-style-type: none"> • External air fitting leaks 	<ul style="list-style-type: none"> • Check hoses and fittings for leaks
	<ul style="list-style-type: none"> • Excessive air leak around depth control knob in the extended position only 	<ul style="list-style-type: none"> • Possible bad o-ring
	<ul style="list-style-type: none"> • Excessive air leak around depth control knob in the extended or retracted position 	<ul style="list-style-type: none"> • Possible bad o-ring on 3-way valve. • Contact Tidland Knifeholder Technician. 1-800-426-1000
	<ul style="list-style-type: none"> • Excessive air leak around the knifeholder actuator switch in the extended or retracted position 	<ul style="list-style-type: none"> • Replace switch
	<ul style="list-style-type: none"> • Body gasket leak 	<ul style="list-style-type: none"> • Check for loose screws between upper and lower body
	<ul style="list-style-type: none"> • Lubrication required on internal body parts 	<ul style="list-style-type: none"> • Refer to manufacturer's manual for disassembly/assembly and lubrication guidelines
	<ul style="list-style-type: none"> • Sticking Piston Assembly due to knifeholder abuse 	<ul style="list-style-type: none"> • Dropping knifeholder or striking with hammer can cause binding. Rebuild knifeholder and replace non-repairable parts
Knifeholder doesn't retract when actuator switch is toggled up	<ul style="list-style-type: none"> • Broken Piston Return Spring 	<ul style="list-style-type: none"> • Refer to Tidland documentation for detailed Dovetail Disassembly Procedure • Refer to Disassembly Procedures for Upper Body, Lower Body and Piston
Depth Control Knob feels excessively tight or loose	<ul style="list-style-type: none"> • Loose or damaged detent 	<p>NOTE: It is important that the detent keeps the depth control knob from rotating during slitting operation. If the detent loosens or breaks, it must be replaced.</p>
Difficult knifeholder movement on guide bar	<ul style="list-style-type: none"> • Dirty guide bar 	<ul style="list-style-type: none"> • Clean and lubricate guide bar with dry film lubricant ex. Dow Corning 557
	<ul style="list-style-type: none"> • Sticky brake shoe 	<ul style="list-style-type: none"> • Clean brake shoe, see illustration in <i>Shear Blade Replacement</i>. • Clean and lubricate brake shoe o-ring. Use Parker Super O-Lube
Blade Cartridge-No Side Stroke	<ul style="list-style-type: none"> • Blade cartridge air supply hose not connected 	<ul style="list-style-type: none"> • Connect air supply hose to blade cartridge

Troubleshooting: Shear Slitting (Slit Quality)

Problem	Possible Cause	Recommended Solution
Low Air Pressure	<ul style="list-style-type: none"> Debris build-up in depth control knob bore 	<ul style="list-style-type: none"> Check air pressure (min. 50 psi required) With air hose, blow out any accumulated dust in the depth control knob counterbore. Remove, clean out and reassemble knob. Replace knob, if necessary. <p>NOTE: Excessive buildup of dust can prevent the 3-way valve from activating the airflow required to shift the cartridge.</p>
Slit Edge is Fuzzy	<ul style="list-style-type: none"> Dull blade 	<ul style="list-style-type: none"> Replace blade.
	<ul style="list-style-type: none"> Incorrectly installed cant key 	<ul style="list-style-type: none"> Correct orientation of cant key, see <i>Cant Key Installation</i>.
	<ul style="list-style-type: none"> Knifeholder is loose on the guide bar 	<ul style="list-style-type: none"> Check the knifeholder to make sure that it is secure on the guide bar mount and check gib adjustment.
	<ul style="list-style-type: none"> Too much overlap 	<ul style="list-style-type: none"> Correct overlap, set to 0.03" (0.8mm).
Slit Line is Not Straight	<ul style="list-style-type: none"> Too much overlap 	<ul style="list-style-type: none"> Correct overlap, set to 0.03" (0.8mm).
	<ul style="list-style-type: none"> Incorrect setback 	<ul style="list-style-type: none"> Check geometry.
Web Tears or Splits	<ul style="list-style-type: none"> Driven anvil run-out Knifeholder is loose on the guide bar 	<ul style="list-style-type: none"> Check the knifeholder to make sure that it is secure on the guide bar mount and check gib adjustment.
	<ul style="list-style-type: none"> Insufficient overspeed of the driven anvil 	<ul style="list-style-type: none"> Adjust overspeed to be 3-5% greater than the winder speed
Web Folds Down	<ul style="list-style-type: none"> Wrong cant key 	<ul style="list-style-type: none"> Replace cant key
	<ul style="list-style-type: none"> Cant key is incorrectly installed 	<ul style="list-style-type: none"> Check web direction, see <i>Cant Key Installation</i>
	<ul style="list-style-type: none"> Dull blade 	<ul style="list-style-type: none"> Replace blade
	<ul style="list-style-type: none"> Incorrect setup 	<ul style="list-style-type: none"> See Knifeholder Installation.
	<ul style="list-style-type: none"> Blade too deep, blade too shallow 	<ul style="list-style-type: none"> Adjust knife
Web Breaks	<ul style="list-style-type: none"> Knife installed incorrectly 	<ul style="list-style-type: none"> Reverse direction of male knife
	<ul style="list-style-type: none"> Web tension too high 	<ul style="list-style-type: none"> Reduce tension.
	<ul style="list-style-type: none"> Low driven anvil speed 	<ul style="list-style-type: none"> Check the driven anvil speed.

Troubleshooting: Shear Slitting (Slit Quality) Continued

Problem	Possible Cause	Recommended Solution
Short Blade Life	• Too much overlap	• Correct overlap, set to 0.03" (0.8mm).
	• Side force too high	• Check air pressure.
	• Driven anvil run-out	• Reset anvil ring.
Web Bunches in Front of Knife Blade	• Insufficient overspeed of the driven anvil	• Adjust overspeed to be 3-5% greater than the winder speed.

Ref. Tidland (Maxcess International)

Score Blade Replacement (Catbridge Score Knife)

Score slitter blades, also called crush cut blades, are used in a cutting process that involves passing a material between a blade and a hardened roll (also known as a sleeve). The material is essentially crushed into two separate pieces between the knife and the roll. Because of the constant metal-on-metal contact between the score cut blade and the roll, these blades do not have a razor sharp edge, but instead have a rounded edge with a larger radius. This insures longer run times, as sharper blades will dull quickly, creating an uneven cut. A score cut knife is used for continuous cutting applications like adhesive tape and similarly gummy webs.

Blade replacement may be facilitated by removing knife holders from knife cutting assemblies.

NOTE: Knife holders are secured to knife cutting assembly with one socket cap screws.



To remove score knife, insert tool (**Catbridge p/n 21742-SBRT**) between sides of the knife holder



and press down to release knife.



NOTE: The following pictures show hidden details of the knife holder and associated parts.



To reassemble, insert the bushing in the bearing and slide knife into the knife holder. Some force is required to seat the bushing into the holder with aid of a plastic or rubber mallet.

In case of a defective air piston, remove the two fasteners with a Torx 20 bit and gently remove the lower assembly.

CAUTION: There are two return springs, which are under pressure and can be ejected from the assembly.



The air piston is located inside of louver assembly.

NOTE: In order to avoid any damage to the sides of the bore, do not use any sharp tools to remove air piston.



Before reassembling, clean all surfaces with a lint free rag and lubricate with Dow Corning Molykote 111.

To reassemble perform the above steps in reverse order. Tighten two fasteners to 40" lbs. Apply a few drops of mineral oil to each felt applicator pad; do not saturate pads.

Score Blade Carriage Alignment (Catbridge Score Knife)

Knife holders shown in previous section are mounted on type A, B C carriage in alternating fashion. See picture below for location of the markings.

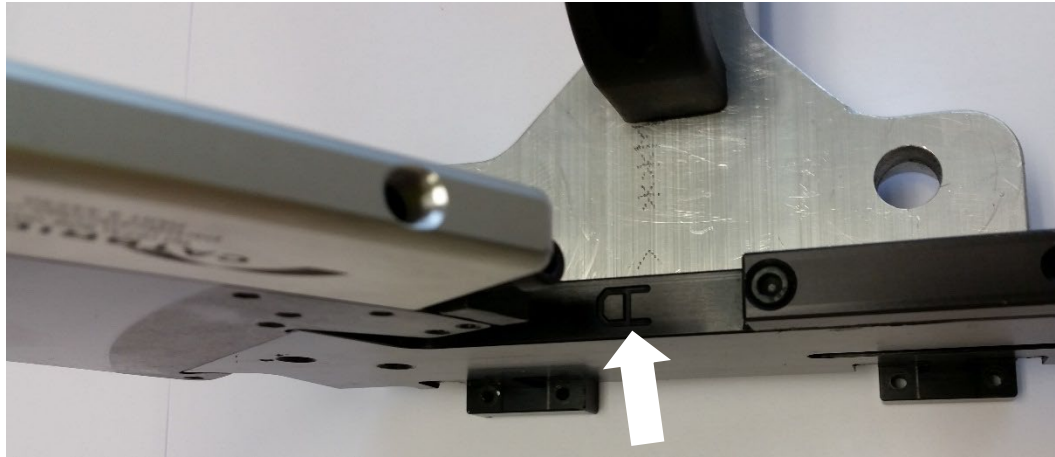

All knives should be moving freely and parallel to each other. In order to align each carriage the alignment tool is used which fits precisely between linear bearings and side of the carriage.

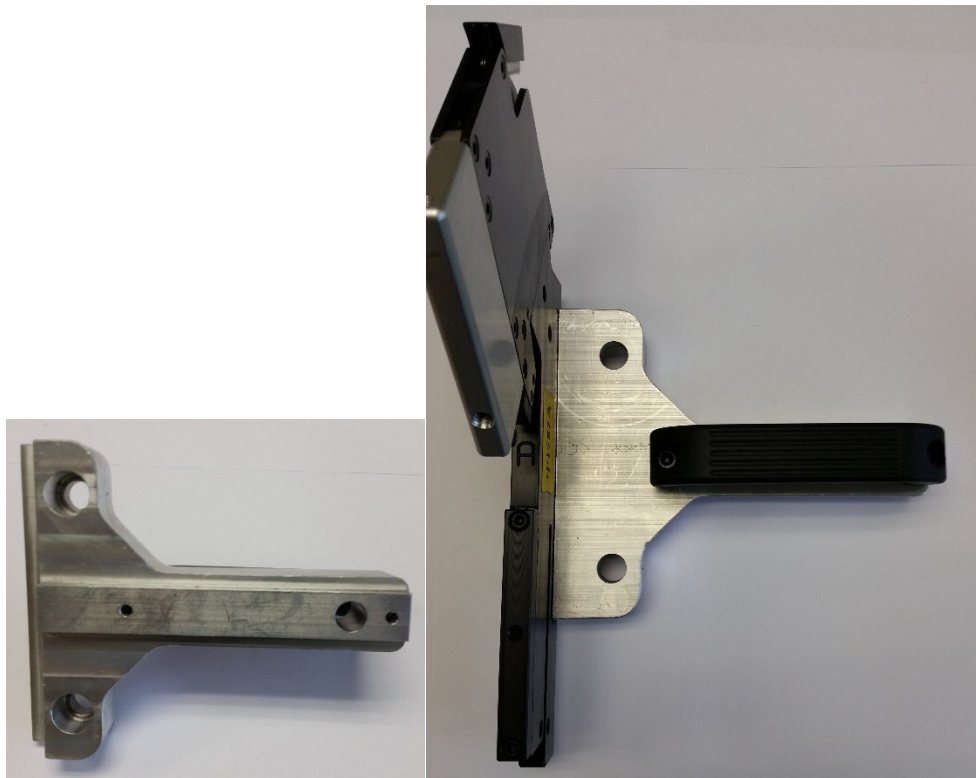

If carriage needs adjustment, all eight bolts securing it to the linear bearing need to be loosened.

NOTE: Bolts are metric.

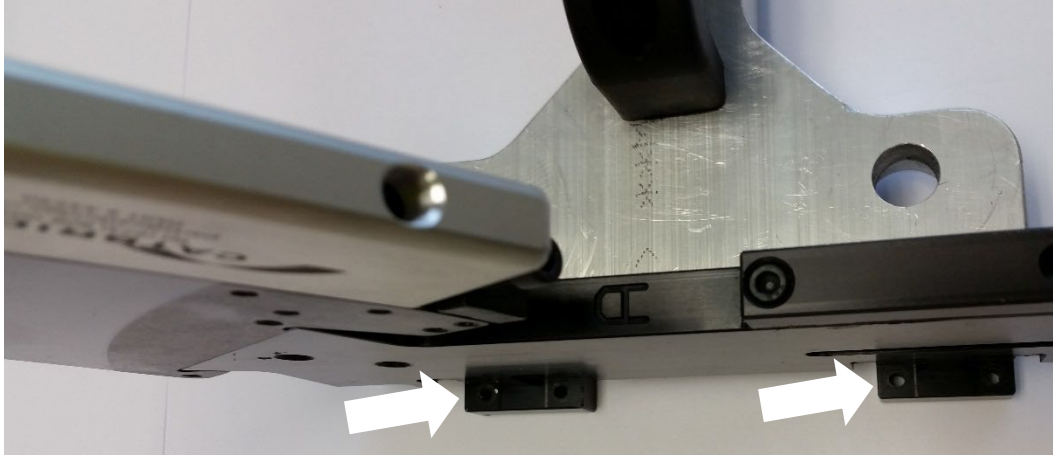

The alignment tool is placed between the rails and the carriage is pushed firmly against the tool as shown below.

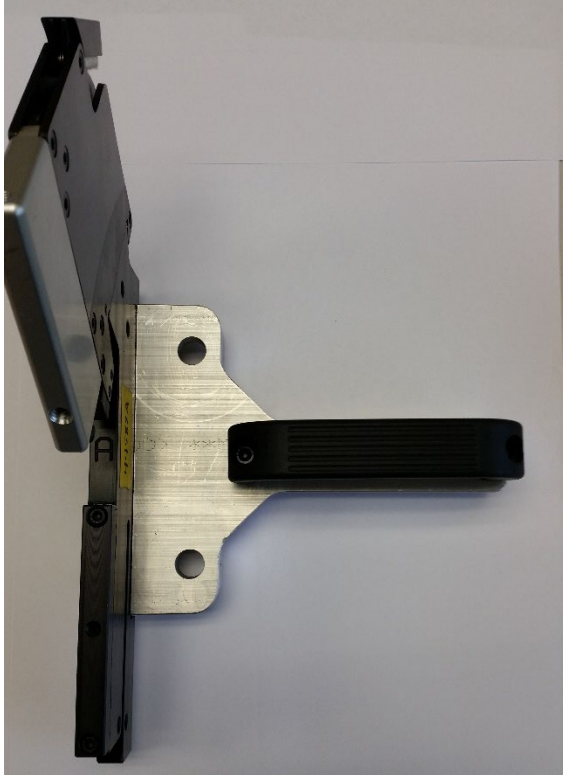

While holding the carriage against the tool, start tightening the four fasteners on the other side of carriage. Do not exceed 24in-lbs. Once first set of bolts are tight, remaining four bolts can be tightened. After carriage is secured, verify alignment with the tool.

If the knives are not stacking flush against each other:

1. It is necessary to check parking brake gaskets between top cap and carriage on affected carriages. Note: If cap is removed, then gasket maybe not reused. When new gasket is installed then it can only be trimmed once top cap is secured. Two fasteners should not be over torqued, otherwise gasket be deformed and cause air leak.



2. If the gaskets are fine, it is necessary to verify that the mating surface between the knife holder and the carriage is free of contaminants and/or any damage.

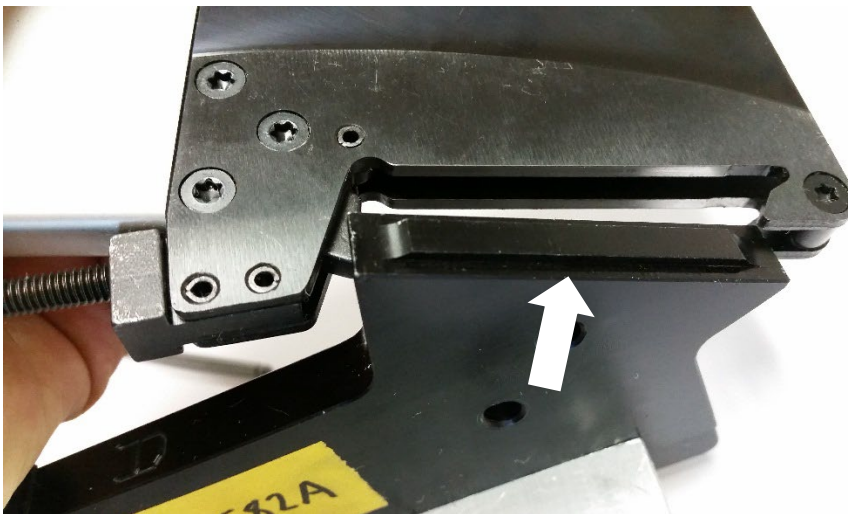

Score Knives Maintenance Schedule

Score Knife	
Preventive	<ul style="list-style-type: none"> • Keep anvil rings and knifeholder blades clean and balanced. • Do not use oil lubricants in knifeholder. Oil lubricants may cause the knifeholder to function improperly. Use only those lubricants recommended in this publication.
Daily	<ul style="list-style-type: none"> • Keep all knifeholders clean of debris. • Check air pressure to the knifeholders: Clean, dry, non-lubricated air is essential for optimal knifeholder performance. • Check for air leaks at the knifeholder and manifold. <p>NOTE: DO NOT IMMERSE knifeholders in solvents. Wipe the outer surfaces with a clean, dry rag.</p>
Weekly	<ul style="list-style-type: none"> • Blow down the blade cartridge to remove dust build up. • Check hose connections to the knifeholders for leaks or cracks.
Monthly	<ul style="list-style-type: none"> • Check adjustment of gib to the guide bar for minimal clearance between knifeholder mount and guide bar. • Clean all surfaces of the control body and blade cartridge.
Bi-Yearly	<ul style="list-style-type: none"> • Clean and inspect blade cartridge bearings for looseness.

Troubleshooting: Knifeholder Performance

Problem	Possible Cause	Recommended Solution
Sluggish Knifeholder Action (extension or retraction)	<ul style="list-style-type: none"> • Low air pressure 	<ul style="list-style-type: none"> • Minimum 50 psi required
	<ul style="list-style-type: none"> • External air fitting leaks 	<ul style="list-style-type: none"> • Check hoses and fittings for leaks
	<ul style="list-style-type: none"> • Excessive air leak around depth control knob in the extended position only 	<ul style="list-style-type: none"> • Possible bad o-ring • See Upper Body & Piston Disassembly Class I, p. 34 Class II, III, p. 36
	<ul style="list-style-type: none"> • Excessive air leak around depth control knob in the extended or retracted position 	<ul style="list-style-type: none"> • Possible bad o-ring on 3-way valve. • Contact Tidland Knifeholder Technician. 1-800-426-1000
	<ul style="list-style-type: none"> • Excessive air leak around the knifeholder actuator switch in the extended or retracted position 	<ul style="list-style-type: none"> • Replace switch
	<ul style="list-style-type: none"> • Body gasket leak 	<ul style="list-style-type: none"> • Check for loose screws between upper and lower body
	<ul style="list-style-type: none"> • Lubrication required on internal body parts 	<ul style="list-style-type: none"> • Refer to manufacturer's manual for disassembly/assembly and lubrication guidelines
	<ul style="list-style-type: none"> • Sticking Piston Assembly due to knifeholder abuse 	<ul style="list-style-type: none"> • Dropping knifeholder or striking with hammer can cause binding. Rebuild knifeholder and replace non-repairable parts
Knifeholder doesn't retract when actuator switch is toggled up	<ul style="list-style-type: none"> • Broken Piston Return Spring 	<ul style="list-style-type: none"> • Refer to Dovetail Disassembly Procedure. • Refer to Disassembly Procedures for Upper Body, Lower Body and Piston.
Depth Control Knob feels excessively tight or loose	<ul style="list-style-type: none"> • Loose or damaged detent 	<p>NOTE: It is important that the detent keeps the depth control knob from rotating during slitting operation. If the detent loosens or breaks, it must be replaced.</p>
Difficult knifeholder movement on guide bar	<ul style="list-style-type: none"> • Dirty guide bar 	<ul style="list-style-type: none"> • Clean and lubricate guide bar with dry film lubricant ex. Dow Corning 557
	<ul style="list-style-type: none"> • Sticky brake shoe 	<ul style="list-style-type: none"> • Clean brake shoe • Clean and lubricate brake shoe o-ring. Use Parker Super O-Lube

Troubleshooting: Knifeholder Performance (Continued)

Problem	Possible Cause	Recommended Solution
Blade Cartridge- no side stroke	<ul style="list-style-type: none"> Blade cartridge air supply hose not connected 	<ul style="list-style-type: none"> Connect air supply hose to blade cartridge
Low Air Pressure	<ul style="list-style-type: none"> Debris build-up in depth control knob bore 	<ul style="list-style-type: none"> Check air pressure (min. 50 psi required) With air hose, blow out any accumulated dust in the depth control knob counterbore. Remove, clean out and reassemble knob. Replace knob, if necessary. <p>NOTE: Excessive buildup of dust can prevent the 3-way valve from activating the airflow required to shift the cartridge.</p>

Troubleshooting: Score Slitting (Slit Quality)

Problem	Possible Cause	Recommended Solution
Slit Edge is Fuzzy	<ul style="list-style-type: none"> Dull blade 	<ul style="list-style-type: none"> Replace blade
	<ul style="list-style-type: none"> Knife pressure too low 	<ul style="list-style-type: none"> Increase knife pressure
	<ul style="list-style-type: none"> Dirt build up 	<ul style="list-style-type: none"> Clean blades & moisten felt pads with mineral oil
Slit Line is Not Straight	<ul style="list-style-type: none"> Worn knife's bearing 	<ul style="list-style-type: none"> Replace bearing
	<ul style="list-style-type: none"> Knife holder is loose on the carriage 	<ul style="list-style-type: none"> Check the knife holder to make sure that it is secure on the carriage.
Web Tears or Splits	<ul style="list-style-type: none"> Knife pressure too low 	<ul style="list-style-type: none"> Increase knife pressure
	<ul style="list-style-type: none"> Insufficient overspeed of the driven anvil 	<ul style="list-style-type: none"> Adjust overspeed to be 3-5% greater than the winder speed
Web Breaks	<ul style="list-style-type: none"> Web tension too high 	<ul style="list-style-type: none"> Reduce tension
Short Blade Life	<ul style="list-style-type: none"> Knife pressure too high 	<ul style="list-style-type: none"> Lower knife pressure
Web Bunches in Front of Knife Blade	<ul style="list-style-type: none"> Insufficient overspeed of the rewind 	<ul style="list-style-type: none"> Adjust overspeed to be 3-5% greater than the winder speed.
	<ul style="list-style-type: none"> Incorrect diameter of the rewind 	<ul style="list-style-type: none"> Check material gauge, core diameter

Score Knife Spare Parts

Item	Description	Quantity	Catbridge p/n
1	Pneumatic Cylinder	1	7055
2	Knife Fork & Piston Assembly	1	7056
3	Rubber Piston Gasket for ½" PQAS Score Knife	1	7057
4	Side Plate (RH)	1	7269
5	Side Plate (LH)	1	7269-1
6	Spacer/Spring Retainer	1	7058
7	Spacer/Spring	1	7059
9	Score Knife (45deg)	1	4323
10	Axle	1	7060
11	Retainer	1	7061
12	Screw	1	7062
13	Clamp	1	7271
14	Spacer	2	7063
15	Piston Return Spring	2	7064
16	Rivet pin	1	7272
17	Screw	8	7065
18	Split Pin	3	7273
19	Bearing	1	7256
22	Air Hose (PVC)	1	7070
23	Air Hose Socket	1	7070s
24	Wick holder	1	30364

Transmissions

Check all transmission attachment points for tightness when performing scheduled maintenance. Drive component vibration or unusual noise may be a signal of loose or worn transmission components. All bearings should exhibit close running clearances. Timing belts should be tight and should not vibrate under load during normal operating conditions. Check the timing belt for wear, cracks, or missing teeth and replace when any of these defects are present.

Stay Clear of Pinch Points, Moving Nip Rolls, and Transmission Drives

NOTE: NO long hair, loose clothing, or jewelry, and exercise extreme caution when working near running machine and rotating shafts.

Moving Nip Rolls, Pinch Points, and Transmission Drives can cause serious injury, trauma, or death by crushing.

Check oil levels in speed reducer gear boxes and replenish with manufacturers recommended lubrication as necessary. Do not overfill gearboxes; see the original equipment manufacturer (OEM) data sheet for specific maintenance details. Similarly, clean and lubricate ball screws and linear bearings during these service intervals.

Unwind Pedestal Centering

Weekly re-center the unwind pedestals with a mill roll or core removed from chucks of the unwind. To re-center pedestals, move each pedestal to the maximum fully opened positions, then, fully close the pedestals. IF one arm reaches the end of travel before the other, continue holding the switch until the other reaches its fully open or closed position. Repeat this motion twice to ensure the units have been centered. This action resets the hydraulic circuit to equalize fluid volume passing through the hydraulic flow divider between the pedestals' cylinders.

V-Belt Tension and Setpoint Adjustment

V-belt drives may be applied to any of the following; platen rolls, bowed rolls, and female knife shafts. The methodology behind applying V-belt drives is to allow a means of adjustability for the drive transmission over the life expectancy of normal equipment operation. For example, a roller's diameter appreciably decreases by multiple resurfacing operations due to normal wear and tear. In order to compensate for this, a V-belt addresses the change in drive belt speed. For this reason, variable pitch sheaves are sometimes used in the V-belt drive system.

Typically, there will be 0.05 to 0.1% gain in web surface speed between any two driven machine rollers. In some cases, gains may be as great as 2%. A tachometer to measure the surface speed of each roller when encountering the increase from upstream to downstream driven rolls can be applied.

As the roller diameter decreases, its rotational speed must increase to maintain the drive gain relationship. This adjustment is made by changing the pitch diameter of the variable pitch sheave to re-establish the theoretical design gain speed using a surface speed measuring tachometer.

Keep checking the surface speed of the driven rollers every 1-2 hours of operation after replacing new V-belts and adjusting variable pitch sheave until no deviation is observed and speed remains constant as expected. New V-belts have a tendency to settle into a formed fit with running sheaves, and during this settling process, some small variations in speed may occur requiring readjustment for correction.

Additionally, any changes made to the V-belt drive system will require tensioning the belts. Generally, the proper tension for a V-belt drive is the lowest belt tension that will not slip over any sheave while transmitting maximum, or peak load. Initial tensioning for new a belt is usually around 15% higher than re-tensioning after the belt has run for 1-2 hours and settled in. Some literature suggests belt settling may take as long as 24 hours run time to complete.

Steel and Aluminum Rolls

Steel and aluminum rolls have no special cleaning methods.

The table below contains guidelines for handling and cleaning of steel and aluminum rolls.

Permitted Cleaning Methods	Types of Contamination	Restrictions
Warm soapy solution using sponge or rag	Water based adhesives, latexes, and starches	None
Mineral spirit and rinse with soapy water	Solvent and oil-based materials	None
Isopropyl alcohol, Denatured Alcohol	Solvent and oil-based materials	None
Pressure washing	Any	Do Not Exceed 3000 PSI.
Doctoring and mechanical scraping	Any	None
Solvents (Toluene, MEK, etc)	Only if regular cleaning methods are not satisfactory	None
Citrus cleaners	Any	None

When using solvents, take precaution and wear gloves when cleaning.

Rubber Coated Rolls

Rolls coated with neoprene, polyurethane, silicone, or that are coated with FDA approved rubber provide greater traction for some products. A normal maintenance program may be required in order for the coating to provide long-term performance .

The table below contains guidelines for handling and cleaning of rubber coated rolls.

Permitted Cleaning Methods	Types of Contamination	Restrictions
Warm soapy solution using sponge or rag	Water based adhesives, latexes, and starches	None
Mineral spirit and rinse with soapy water	Solvent and oil-based materials	None
Isopropyl alcohol, Denatured alcohol	Solvent and oil-based materials	Only wipe with alcohol and do not let alcohol soak into the roll.
Pressure washing	Any	Do not exceed 3000 PSI.
Doctoring and mechanical scraping	Any	DO NOT DO! Roll is soft and will get scratched from scraping.
Solvents (Toluene, MEK, etc)	Only if regular cleaning methods are not satisfactory	Only wipe with solvent and do not let solvent soak into the rubber. Rinse with water and allow to dry.
Citrus cleaners		DO NOT USE! Contact with this cleaner will cause the rubber to dry out and fail prematurely.

When using solvents, take precaution and wear gloves when cleaning.

Plasma Coated Rolls

Plasma coatings prevent adhesives from sticking, providing greater traction for some products and providing greater wear resistance. The uses of these coatings are designed to eliminate or reduce the need and effort to clean the coated surfaces. A normal maintenance program may be required in order for the coating to provide long-term performance.

The table below contains guidelines for handling and cleaning of plasma coated rolls.

Permitted Cleaning Methods	Types of Contamination	Restrictions
Warm soapy solution using sponge or rag	Water based adhesives, latexes, and starches	None
Mineral spirit and rinse with soapy water	Solvent and oil-based materials	None
Isopropyl alcohol, Denatured alcohol	Solvent and oil-based materials	None
Pressure washing	Any	Do not exceed 3000 PSI
Doctoring and mechanical scraping	Any	Light pressure with fiber or brass material
Solvents (Toluene, MEK, etc)	Only if regular cleaning methods are not satisfactory, understanding that the coating WILL be affected by its use.	Only wipe with solvent and do not let solvent soak the plasma coating. Rinse with water and allow to dry. Prolonged contact with solvents will cause swelling and blistering of the plasma coating.
Citrus cleaners		DO NOT USE! Contact with this cleaner will cause blistering and peeling of the plasma coating.

Other factors causing detrimental effect on the coatings performance include:

- 1) Caustics, in excess of the limitation of range specified in data sheets may result in peeling and/or blistering. Rinse surface with water if exposed to minimize this problem.
- 2) Plasticizers can attack the coating causing softening and possible delamination.
- 3) Temperatures in excess of those specified by vendor will damage coating.

Nexen Clutches

When clutch/brake system performance deteriorates (e.g., excessive pulsing, not holding required tension/tension) please contact Catbridge Parts Department (Parts@Catbridge.com) to request a new assembly calibrated to your machine's specifications.

Clutch Maintenance Schedule

	Action
Preventive	
Daily	<ul style="list-style-type: none"> • Check for air leaks • Inspect all cap and set screws and make sure they are tightened to the recommended torque
Monthly	<ul style="list-style-type: none"> • Clean assembly of friction material dust
Quarterly	<ul style="list-style-type: none"> • Check thickness of friction material; replace when worn to approximately 5/32" (4mm) thick

Troubleshooting: Clutch Performance

Problem	Possible Cause	Recommended Solution
Failure to Engage	<ul style="list-style-type: none"> • Air not getting to Tension Control Clutch 	<ul style="list-style-type: none"> • Check for control valve malfunction or low air pressure
	<ul style="list-style-type: none"> • Low air pressure 	
	<ul style="list-style-type: none"> • Control malfunction 	<ul style="list-style-type: none"> • Check controls
Failure to Disengage	<ul style="list-style-type: none"> • Unexhausted air 	<ul style="list-style-type: none"> • Check for control valve malfunction
	<ul style="list-style-type: none"> • Control malfunction 	<ul style="list-style-type: none"> • Check Controls
Loss of Torque	<ul style="list-style-type: none"> • Air leak 	<ul style="list-style-type: none"> • Check for air leaks
	<ul style="list-style-type: none"> • Friction facing contamination 	<ul style="list-style-type: none"> • Check air pressure
	<ul style="list-style-type: none"> • Worn friction facings 	<ul style="list-style-type: none"> • Contact Catbridge Part and Service department for replacement calibrated clutch assembly
	<ul style="list-style-type: none"> • Low air pressure 	
Friction Facing Squeal or Chatter	<ul style="list-style-type: none"> • Air pressure too high 	<ul style="list-style-type: none"> • Reduce air pressure
	<ul style="list-style-type: none"> • Wrong friction facing for application 	<ul style="list-style-type: none"> • Check friction facing
Noise (other than facing squeal)	<ul style="list-style-type: none"> • Bearing failure 	<ul style="list-style-type: none"> • Replace bearings
	<ul style="list-style-type: none"> • Loose fasteners 	<ul style="list-style-type: none"> • Tighten fasteners
Wobble or Vibration	<ul style="list-style-type: none"> • Improper mounting 	<ul style="list-style-type: none"> • Remount unit
	<ul style="list-style-type: none"> • Faulty shaft 	<ul style="list-style-type: none"> • Replace shaft

Montalvo Brakes

When brake system performance deteriorates (e.g., excessive pulsing, not holding required tension/tension) please contact Catbridge Parts Department (Parts@Catbridge.com) to request new assembly calibrated to machines specifications.

Brake Maintenance Schedule

	Action
Preventive	
Daily	<ul style="list-style-type: none"> • Check for air leaks. • Inspect all cap and set screws and make sure they are tightened to the recommended torque.
Monthly	<ul style="list-style-type: none"> • Clean assembly of friction material dust.
Quarterly	<ul style="list-style-type: none"> • Check thinness of friction material; replace when worn to approximately 5/32" (4mm) thick.

Troubleshooting: Brake Performance

Problem	Possible Cause	Recommended Solution
Failure to Engage	• Air not getting to Tension Control Clutch	• Check for control valve malfunction or low air pressure
	• Low air pressure	
	• Control malfunction	• Check controls
Failure to Disengage	• Unexhausted air	• Check for control valve malfunction
	• Control malfunction	• Check Controls
Loss of Torque	• Air leak	• Check for air leaks
	• Friction facing contamination	• Check air pressure
	• Worn friction facings	• Contact Catbridge Part and Service department for replacement calibrated clutch assembly
	• Low air pressure	
Friction Facing Squeal or Chatter	• Air pressure too high	• Reduce air pressure.
	• Wrong friction facing for application	• Check friction facing
Noise (other than facing squeal)	• Bearing failure	• Replace bearings
	• Loose fasteners	• Tighten fasteners
Wobble or Vibration	• Improper mounting	• Remount unit
	• Faulty shaft	• Replace shaft.

Section
7
LUBRICANTS
Lubricants

APPLICATION	DESCRIPTION	McMASTER P/N	CATBRIDGE P/N
Bladder	<ul style="list-style-type: none"> DuPont Molykote 111 	1204K32	33088
Differential Shaft	<ul style="list-style-type: none"> Felt-Super Lube® Aerosol with Syncolon® (PTFE) 	1378K32	44302
	<ul style="list-style-type: none"> Shaft – Super Lube® DRI-FILM lubricant 	1155K24	37383
SuperChuck	<ul style="list-style-type: none"> Mobil Mobilith SHC PM 460 	1394K2	36191
Hydraulic System	<ul style="list-style-type: none"> HyPar FG-32 – food grade 	N/A	37964-32
	<ul style="list-style-type: none"> Shell Tellus S2 M 32 - regular 		4495
Open Gears (e.g., Turret Gears)	<ul style="list-style-type: none"> Dow Corning Molykote D-321 	1254K18	32837
Linear Bearing and Screw Shafts	<ul style="list-style-type: none"> Mobil Mobilith SHC PM 460 	1394K2	36191
Gearbox	<ul style="list-style-type: none"> Lubriplate PGO FGL-460 	N/A	39900-460
	<ul style="list-style-type: none"> Synthetic ISO 460 – Dodge Tigear only 	Dodge #334862 (Gal) Dodge #334863 (Quart)	N/A
Shear Shaft	<ul style="list-style-type: none"> Only Dry silicone lubricant ex. DuPont Molykote 557 	1254K22	74292
Guide Bar (Knives)	<ul style="list-style-type: none"> Only Dry silicone lubricant ex. DuPont Molykote 557 	1254K22	74292
Score Knife Bladder	<ul style="list-style-type: none"> DuPont Molykote 111 	1204K32	33088

Section

10

REVISION HISTORY

Version	Changes	date
0.1	Initial	October 18,2016
0.2	Leveling and Alignment	October 19,2016
0.3	Anvil knife removal	October 20,2016
1.0	New format	October 20,2016
1.1	New sections	October 21,2016
1.2	Formatting	November 3,2016
1.3	Formatting	November 10, 2016
1.4	Compressed Pictures to reduce file sizing for emailing	November 21, 2016
1.5	729 cylinder prox	April 12, 2017
1.6	Score knife carriage allign	April 25, 2017
1.7	Aluminum, steel, and rubber coated roll cleaning	March 29, 2023