



**C 150 H**  
**C 150 H x4**  
**C 200 H**  
**C 200 H x4**  
**C 250 H**  
**C 250 H x4**



**FullGrip® System exclusivo AUSA:**  
 Tracción integral por discos múltiples conectable electro-hidráulicamente desde el mando joystick.

**Exclusive AUSA FullGrip® System:**  
 On demand 4WD connectable by means multiple discs with electro-hydraulic engagement from the joystick.

**FullGrip® System de AUSA:**  
 4 RM sur demande au moyen de disques multiples avec connexion electro-hydraulique depuis le joystick.

**AUSA FullGrip® System:**  
 Elektrohydraulisch, zuschaltbarer Allradantrieb – am Joystick zu betätigen.



**Compen® System exclusivo AUSA:**  
 Tracción integral permanente que compensa automáticamente el par entre los ejes diferenciales.

**Exclusive AUSA Compen® System:**  
 Permanent 4WD that compensates automatically the torque between the both axes.

**Compen® System de AUSA:**  
 4 RM permanentes qui compense automatiquement le couple entre les deux essieux.

**AUSA Compen® System:**  
 Permanenter Allradantrieb mit automatischem Drehmoment-Ausgleich zwischen Vorder - Hinter Achse.



**C 150 H/x4\_1500Kg**  
**C 200 H/x4\_2000Kg**  
**C 250 H/x4\_2500Kg**

DIMENSIONS (mm)	C 150 H	C 150 Hx4	C 200 H	C 200 Hx4	C 250 H	C 250 Hx4
A	1990	2020	2050	2050	2150	2150
B	220	250	210	210	250	270
C	215	215	310	310	390	390
D	-	-	1375	1392	1375	1392
E (narrow axle)	1305	1305	1520	1520	1540	1540
E (wide axle)	-	-	1770	1770	1800	1800
F	2550	4000	2800	4040	2800	4040
G	2350	2550	2600	2900	2600	2900
I	100	100	100	100	130	130
J	35	35	40	40	45	45
K	500	500	610	610	615	615
L	3645	3645	4240	4240	4240	4240
M	390	390	580	580	580	580
N	1740	1740	1850	1850	1850	1850
O	1000	1000	1200	1200	1200	1200
P	4250	5700	4700	6300	4700	6300
Q	10°	10°	13°	13°	13°	13°

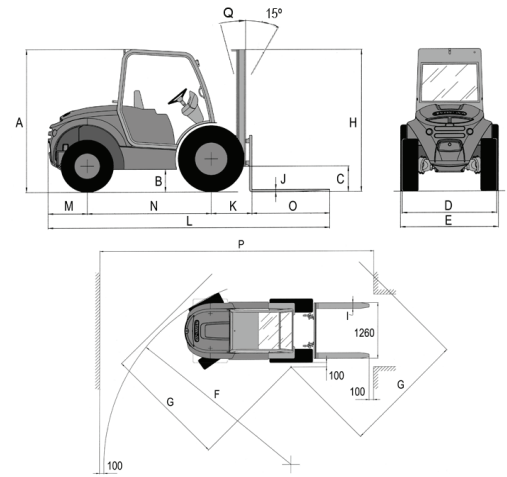

www.ausa.com

Type of mast	Maximum lifting height (mm)	Free lift (mm)	Machine height with mast retracted (mm)			Machine height with mast extended (mm)			Load (Kg) at max. height - according stability test standard (A/B)*							
			C 150 H/Hx4	C 200 H/Hx4	C 250 H/Hx4	C 150 H/Hx4	C 200 H/Hx4	C 250 H/Hx4	(A)	(B)	(A)	(B)	(A)	(B)		
Duplex (Std.)	3300	120	-	2395	2460	-	4150	4215	-	-	2000	2000	2000	2500	2500	2500
Duplex	2600	120	-	2045	2110	-	3450	3515	-	-	2000	2000	2000	2500	2500	2500
Duplex	3600	120	-	2545	2610	-	4450	4515	-	-	2000	2000	2000	2300	2400	2500
Duplex	4500	120	-	2995	3060	-	3530	5415	-	-	-	1800	1800	-	2100	2500
Triplex (free lift)	3700	1130	-	2045	2120	-	4590	4665	-	-	1800	2000	2000	2200	2300	2500
Triplex (free lift)	4300	1330	-	2245	2320	-	5230	5300	-	-	-	1800	1800	-	2100	2500
Triplex (free lift)	5400	1680	-	2610	2685	-	6295	6370	-	-	-	1100	1700	-	1100	2200
Duplex (Std.)	2660	0	1975	-	-	3285	-	-	1500	1500	-	-	-	-	-	-
Duplex	3300	0	2325	-	-	3925	-	-	1350	1500	-	-	-	-	-	-
Duplex (free lift)	2600	1360	1975	-	-	3270	-	-	1500	1500	-	-	-	-	-	-
Triplex (free lift)	4000	1360	1975	-	-	4670	-	-	1200	1300	-	-	-	-	-	-

**TECHNICAL SPECIFICATIONS**

	C 150 H / C 150 Hx4	C 200 H / C 200 Hx4	C 250 H / C 250 Hx4
Load capacity (kg) @ centre of gravity	1500 @ 500 mm / 1350 @ 600 mm	2000 @ 500 mm / 1850 @ 600 mm	2500 @ 500 mm / 2300 @ 600 mm
Lifting height (Standard duplex mast) (mm)	2660		
Engine	Diesel KUBOTA V 1505 Power acc. (KW/HP) 22.7 / 30.8 (SAE J 1995) N° of cylinders 4 Cooling system Water	ISUZU 4LE2 / KUBOTA V 2403 M 33.8 / 36.5 (SAE J 1995)	KUBOTA V 2403 M 36.5 (SAE J 1995)
Traction	4x2 / 4x4 Compen®	4x2 / 4x4 FullGrip®	4x2 / 4x4 FullGrip®
Transmission	Hydrostatic with variable flow pump. Two speed hydrostatic motor. Electrical reverser in joystick. Inching pedal.	Hydrostatic with variable flow pump. Two speed engine. Electrical reverser in joystick. Inching pedal.	Hydrostatic with variable flow pump. Electrical reverser in joystick. Inching pedal.
Unladen weight (Kg) (with full tanks)	2600	3800 (4x2) / 4100 (4x4)	4200 (4x2) / 4300 (4x4)
Gradeability	25%	26% (4x2) / 38% (4x4)	25% (4x2) / 37% (4x4)
Speed (Maximum) (Km/h)	20		
Engine starting system	Electric		
Tyres	Front Rear 6.00-9 (C150H) / 23 x 8.50 - 12 (C150 Hx4)	7.00-12 (C200H) / 27x10.5-15 (C200 Hx4)	7.00-12 (C250H) / 10.0 / 75 - 15.3 (C250 Hx4)
Steering	Hydraulic. Working pressure 130 bar.		
External turning radius (mm)	2550 (4x2) / 4000 (4x4)		2800 (4x2) / 4040 (4x4)
Tank capacity (l)	Fuel Hydraulic fluid 45 40	50 40	50 40
Service brake	Oil-immersed, multidisc		
Parking brake	Oil-immersed multidisc		
Hydraulic circuit	2 gear pump of 10.6 and 6 cc. Working Pressure 200 bar.	18-8 cc. double gear pump. Working Pressure 180 bar.	18-8 cc. double gear pump. Working Pressure 210 bar.
Operating pressures for accessories	200		180
Forkcarriage	FEM 2 - Wide 1260 mm (optional 1600 mm)		
Stability test standard	(A)* (B)*	For rough terrain use - Models H - ISO 22915-13 For industrial use - Models HI - ISO 22915-2	

**STANDARD EQUIPMENT**

Open tilting Cabin	Open tilting cabin
Ergonomic seat	Ergonomic seat with safety belt
Seat Belt	Joystick with integrated functions "total control of movements"
Joystick with integrated functions "total control of movements"	Rotating beacon
Rotating beacon	3rd. auxiliary hydraulic service
3rd. auxiliary hydraulic service	Side-shift: 1260 mm (width)
Side-shift: 1260 mm (width)	Active security equipment
Active security equipment	Audible reverse warning
Audible reverse warning	Chassis mounted integral belly plate

**OPTIONAL EQUIPMENT**

Semi-closed cabin	Semi-closed cabin
Great confort seat	Full cabin with heater
Full cabin with heater	Air conditioning
Air conditioning	Radio/Stereo CD
Radio/Stereo CD	Anti theft protection system
Anti theft protection system	Homologated lighting system
Homologated lighting system	Working lights
Working lights	Catalytic converter
Catalytic converter	Spark Arrestor
Spark arrestor	Fuel oil filter with water separator
Fuel oil filter with water separator	4 th auxiliary hydraulic service
4th auxiliary hydraulic service	5 th auxiliary hydraulic service
5 th auxiliary hydraulic service	Wide front axle
300 litre and 400 litre hydraulic buckets	Load backrest of 1260 mm and 1600 mm
Load backrest of 1260 mm	Side-shift: 1600 mm (width)
Side-shift: 1600 mm (width)	400 litre and 600 litre hydraulic buckets
400 litre and 600 litre hydraulic buckets	Tyres: solid, flotation, industrial
Tyres: solid, flotation, industrial	Other multiple attachments fitted with manufacturer warranty
Other multiple attachments fitted with manufacturer warranty	Other multiple attachments fitted with manufacturer warranty