

# Urschel® Model CC

## VERSATILE SLICER, SHREDDER, & GRANULATOR

Food processors rely on the Urschel Model CC to produce precise, uniform slices and shreds at high production capabilities with excellent results including potato slices, shredded cheese, and many other reductions including nuts, vegetables, and pet food. Laser-cut frame design delivers increased sanitation and flexibility. Choose from left- or right-side electrical enclosure machine build. Options include cutting enclosure choices of 22" (559 mm), 26" (660 mm), or 32" (813 mm) and motor choices of 2 HP (1.5 kW), 5 HP (3.7 kW), or 10 HP (7.5 kW). The stainless steel slicer features continuous operation for uninterrupted production and is designed for easy cleanup and maintenance. The Model CC will accept products measuring up to 4" (101.6 mm) in any dimension.



### CUTS

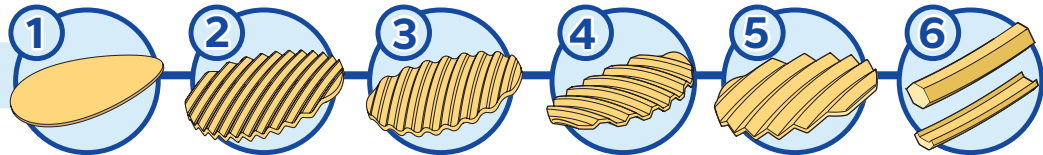

#### 1 Flat Slice

Slice thickness up to .500" (12.7 mm)

#### 2 V Slice

Slice thickness up to .500" (12.7 mm)

**.125" Slice:** 8 "V"s per inch. "V" depth of .050" (1.3 mm); Centers: .125" (3.2 mm).

**.212" Slice:** 4.7 "V"s per inch. "V" depth of .084" (2.1 mm); Centers: .212" (5.4 mm).

#### 3 Crinkle Slice

Slice thickness up to .500" (12.7 mm).

**.175" Slice:** Crinkle Depth .084" (2.1 mm), Centers .175" (4.4 mm),

**.300" Slice:** Crinkle Depth .080" (2.0 mm), Centers .300" (7.6 mm).

**.480" Slice:** Crinkle Depth .076" (1.9 mm), Centers .480" (12.2 mm).

#### 4 Flat-V® Slice

Slice thickness up to .180" (4.6 mm) with 2.1 corrugations per inch. Corrugation depth of .125" (3.2 mm); Centers: .473" (12 mm).

#### 5 \*\*Z-Cut Slice

Slice thickness up to .325" (8.3 mm) with 2.1 corrugations per inch. Corrugation depth of .135" (3.4 mm); Centers: .394" (10 mm).

#### 6 Full & Reduced Flat-V® Shreds

**Full Flat-V Shred:** Hexagonal-shaped cross section approximately .150" (3.8 mm) on all sides.

**Reduced Flat-V Shred:** Flattened top and bottom that form a corrugated shred.

#### 7 Full & Reduced V Shreds

**Full Shred:** Diamond-shaped cross section available in four thicknesses: .070, .097, .125, or \*.285" (1.8, 2.5, 3.2, or \*7.2 mm).

**Reduced V Shred:** "V"-shaped cross section

#### 8 Oval & Reduced Oval (Crescent) Shreds

**.250" Oval Shred:** Oval-shaped cross section approximately .125" (3.2 mm) thick by .250" (6.4 mm) wide.

**Crescent Shred:** Crescent-shaped cross section.

#### 9 Wide Oval Shreds & Wide Reduced Oval (Crescent) Shreds

**.480" Wide Oval Shred:** Wide oval-shaped cross section .152" (3.7 mm) thick by .480" (12.2 mm) wide.

**Wide Crescent Shred:** Wide crescent-shaped cross section.

#### 10 Strip Cut

Rectangular cross section.

**Width:** 3/32, 1/8, 3/16, 1/4, 3/8, 1/2, 9/16, or 3/4" (2.4, 3.2, 4.8, 6.4, 9.5, 12.7, 14.3, or 19 mm)

#### 11 Grating Options

Grating heads offer cuts such as powdered parmesan, coarse granules, and shreds.



\* Limited availability based on customer application. Contact your local Urschel office to verify salability.

\*\* Z-Cut is only available in non-European countries.

### CUTTING OVERVIEW

1. Impeller Paddle
2. Slicing Knife

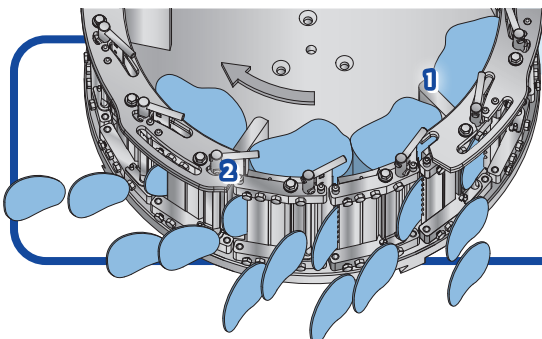

If your product application is not mentioned on this page, contact your local Urschel representative to determine the most effective solution to your size reduction needs.

# URSCHEL® MODEL CC



Measurements and weights may vary depending on machine configuration.

**Length:** 59.63" (1515 mm) - 2 or 5 HP  
 ..... 61.94" (1573 mm) - 10 HP

**Width:** 45.64" (1159 mm)

**Height:** 35.60" (904 mm)

**Net Weight:**  
 550 lb (250 kg) - 2 or 5 HP  
 680 lb (310 kg) - 10 HP

**Motor:**  
 2, 5, or 10 HP (1.5, 3.7, or 7.5 kW)



*Model CC Image Shows:  
 24" Diameter Enclosure, Potato Hopper  
 2 or 5 HP Stainless Steel Motor, Right Side Electrical*

SPECIFICATIONS & DIMENSIONS

### 32" Enclosure, 2, 5 or 10 HP Potato Hopper, Left Side Electrical

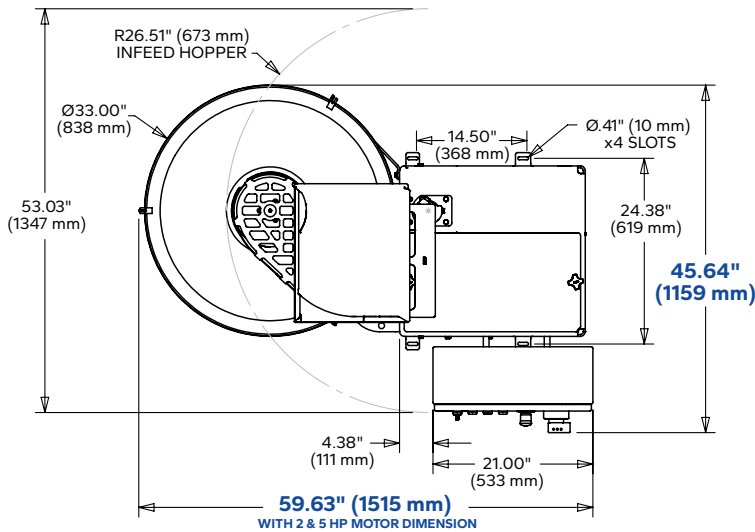

### MODEL CC

Available Options for Your Line

#### ENCLOSURE ASSEMBLIES

- 22" (559 mm) Diameter Enclosure
- 26" (660 mm) Diameter Enclosure
- 32" (813 mm) Diameter Enclosure

#### INFEED ASSEMBLIES

- Potato Hopper
- Swing Away Funnel Hopper

#### MOTOR

- 2 HP (1.5 kW)
- 5 HP (3.7 kW)
- 10 HP (7.5 kW)

#### ELECTRICAL ENCLOSURE

Left or Right Side

### 32" Enclosure, 2 or 5 HP Swing Away Funnel Hopper

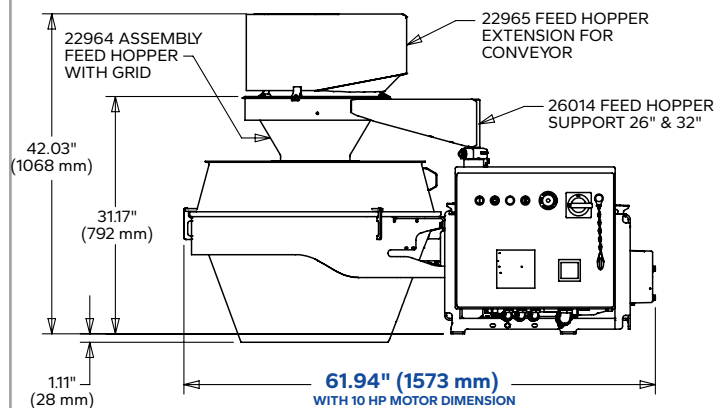
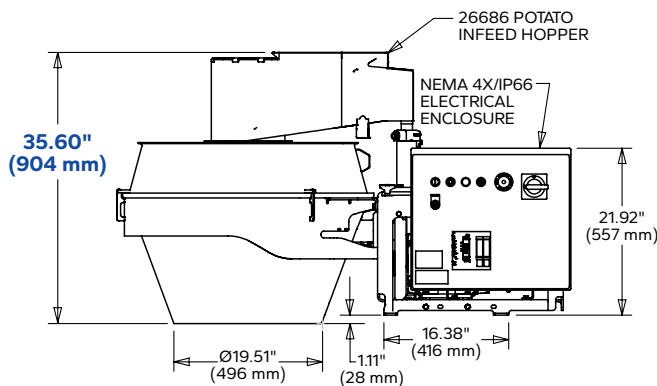

## Test Cut Your Product

Contact your local Urschel representative to schedule a comprehensive, no-obligation test-cut of your product: [www.urschel.com](http://www.urschel.com).



# URSCHEL®

The Global Leader in Food Cutting Technology

[www.urschel.com](http://www.urschel.com) | [info@urschel.com](mailto:info@urschel.com)

© Urschel logo symbol, Urschel, The Global Leader in Food Cutting Technology, and Flat-V are registered trademarks of Urschel Laboratories, Inc.  
 †† The Model CC series may contain parts protected by U.S. & International Patent nos. 7658133, 8161856, 9469041, 9517572, 9840015, 9849600, 9862113, 9902080, 10279495, 10328598, 10456943, 10562203, 10780602, 10786922, 10807268, 10933552, 11298849, 12083699, 11027450, 11090829, 11117285, 11364650, 11428519, 12097634, 12220831, 12280515, 25158412.4, 251811071, 2022-567261, 2022292660, 2024219748, BR112023024929-5, 3220790, 22825803.4, and 2023-576056.