

Dry Stoner, Type MTSB

Features

- High accuracy of separation, thanks to preliminary and final separation zones and excellent distribution of air across the entire screen
- Accurate final separation of product from heavy impurities due to the adjustable counter-current of air
- High capacity combined with low air volume and minimum power requirements
- Insensitivity towards variations of capacity
- Simple drive with vibrator; deck supported on springs, made for quiet running

- Exchangeable deck with removable perforated metal screen
- Suction system with co-oscillating polyester hood for dust-free operation
- Virtually maintenance-free
- With inside lighting on request

Dimensions for sketch in ft., in. and mm (Metric measures in italics)

Type	A	B	C	D	E	F	G	H ϕ	J ϕ	K ϕ	L	M
MTSB-50	5'8 ⁷ / ₈ " 1750	2'5 ⁷ / ₈ " 760	5'1 ⁴ / ₄ " 1530	2'2 ³ / ₄ " 680	2'9 ¹ / ₂ " 850	3'7 ⁷ / ₈ " 1115	1'6 ⁷ / ₈ " 480	4 ³ / ₄ " 120	9 ⁷ / ₈ " 250	4 ³ / ₄ " 120	10" 255	1'7 ⁵ / ₈ " 500
MTSB-100	5'8 ⁷ / ₈ " 1750	4'7 ⁷ / ₈ " 1420	5'1 ⁴ / ₄ " 1530	2'2 ³ / ₄ " 680	2'9 ¹ / ₂ " 850	3'7 ⁷ / ₈ " 1115	1'6 ⁷ / ₈ " 480	4 ³ / ₄ " 120	1'1 ³ / ₄ " 350	4 ³ / ₄ " 120	1'4 ⁷ / ₈ " 430	1'11 ⁵ / ₈ " 600
MTSB-150	5'8 ⁷ / ₈ " 1750	6'7 ¹ / ₂ " 2020	5'1 ⁴ / ₄ " 1530	2'2 ³ / ₄ " 680	2'9 ¹ / ₂ " 850	3'7 ⁷ / ₈ " 1115	1'6 ⁷ / ₈ " 480	4 ³ / ₄ " 120	1'5 ³ / ₄ " 450	4 ³ / ₄ " 120	3'8 ¹ / ₄ " 1125	3'3 ³ / ₈ " 1000

Technical data, weights, etc. (Metric measures in italics)

Type	Throughput t/hr approx. figures for cocoa beans*	Power installed kW	Motor speed r.p.m.		Air con- sumption m ³ per min.	Negative pressure mbar	Approximate weights in lbs./kg			Shipping volume cu. ft./ m ³
			50 cps	60 cps			Net	Gross	For export	
MTSB-50	1.5-2	0.3	920	840	50-55	12-15	460 210	705 320	830 375	88 2.5
MTSB-100	3-4	0.3	920	840	100-110	12-16	605 275	990 450	1170 530	145 4.1
MTSB-150	4-6	0.3	920	840	150-165	12-18	880 400	1370 620	1570 710	194 5.5

* Capacities, air volume requirements and negative air pressures are guidelines for cocoa beans; figures for other materials available on request.

We are constantly striving to improve our products and therefore reserve the right to change design, material and specifications without previous notice.

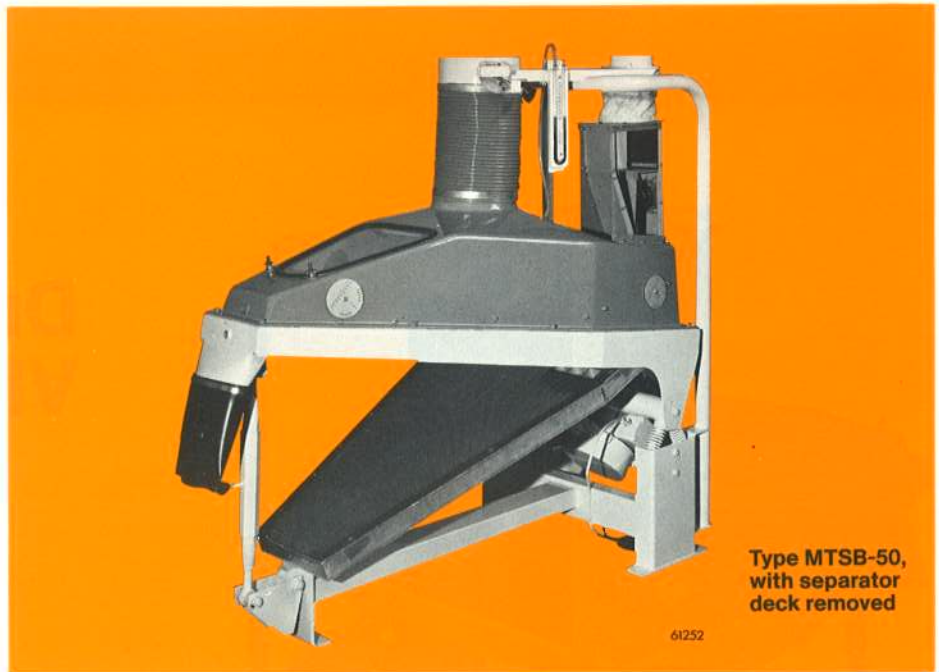
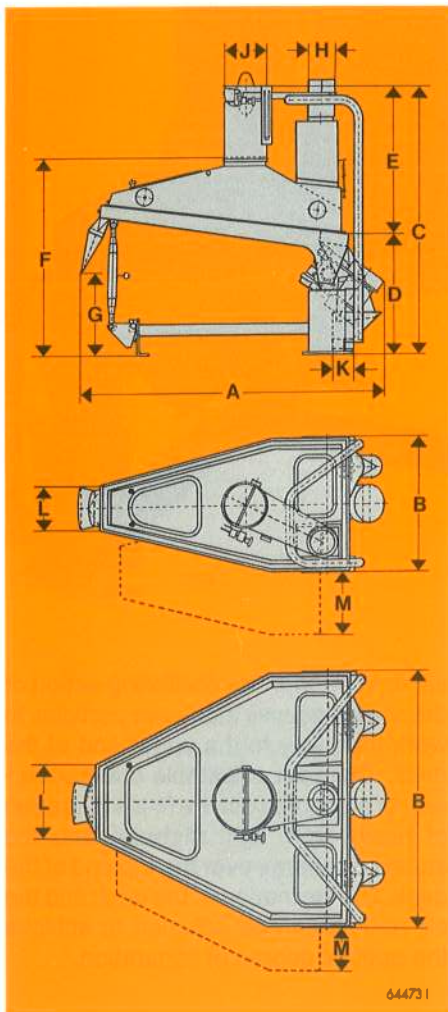

Type MTSB-50,
with separator
deck removed

61252

644731



BUHLER BROTHERS Ltd., CH-9240 Uzwil/Switzerland
Phone (073) 50 11 11, Telex 883 134 gbu ch, Telefax (073) 50 33 79
BUHLER-MIAG Ltd., D-3300 Braunschweig/FRG
Phone (0531) 59 40, Telex 9 527 000 bm d, Telefax (0531) 59 42 25 4