

36119

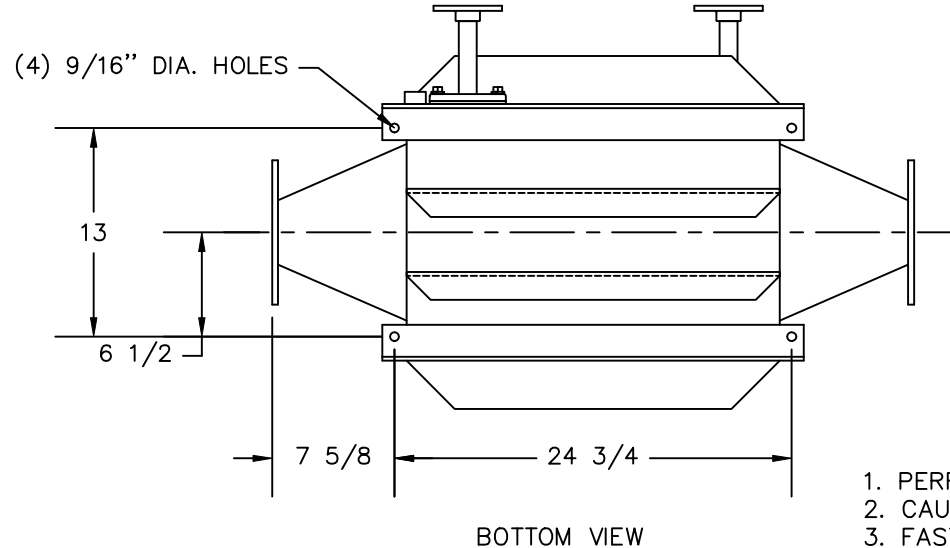
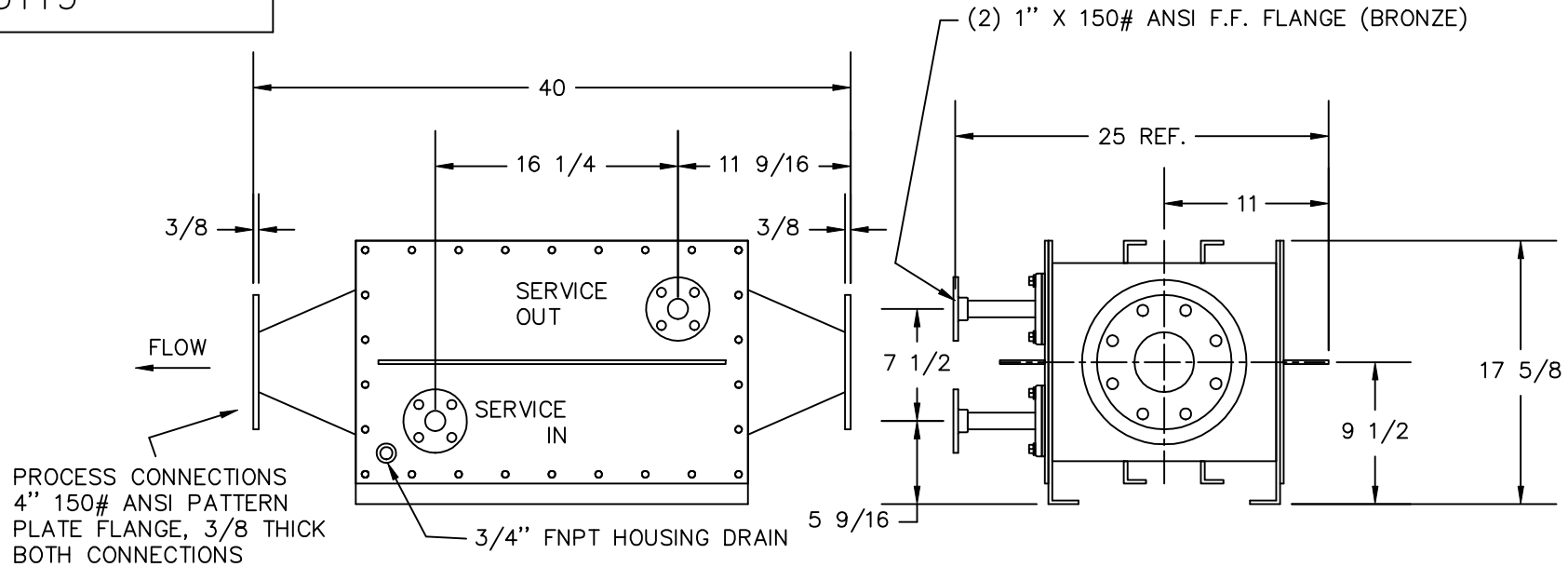

Xchanger Inc.
Hopkins, Minnesota

CUSTOMER P.O.: 40042-2661
Reimelt Corporation

MODEL NUMBER: C-075 P/N: 36119
Tag: 02661-HX7128, 02661-HX7130

SERIAL NUMBER: 0503-B8422-2

1. PERFORMANCE AND CONSTRUCTION PER DATA SHEET #69216 & #69217
2. CAUTION: CORE IS NOT DRAINABLE-PROTECT FROM FREEZING
3. FASTENERS WILL BE ZINC PLATED STEEL
4. QUANTITY OF - 2 - REQUIRED

TOLERANCES (UNLESS OTHERWISE NOTED)		Xchanger Inc. 1401 SOUTH 7TH ST HOPKINS, MN 55343		MODEL C-075 HEAT EXCHANGER ASSEMBLY			
DECIMAL ± .25	FRACTIONAL ± 1/4	DRAWN BY: MJR APPROVED BY: .	SCALE: NONE DATE: 06/04/03	JOB NUMBER B8422-2	SHEET 1 OF 1	DRAWING NUMBER 36119	REV. A