



Operation Manual

FLEXITHERM™ - Pasteurization



ORIGINAL INSTRUCTION

Document producer

Alfa Laval Copenhagen A/S
Maskinvej 5
DK-2860 Søborg/Copenhagen
DENMARK

Further copies

Can be ordered from nearest Alfa Laval company. When ordering, always state the module type and Serial No. as stated on the name plate.

Copyright ©

All rights reserved. No part of this documentation may be reproduced or copied in any form or by any means without the written consent of Alfa Laval Copenhagen A/S.

TABLE OF CONTENTS

GENERAL INFORMATION7

SAFETY INSTRUCTIONS9

Use of hazard informations9

Use of signs10

Cleaning solution11

Gas11

GENERAL DESCRIPTION13

Denominations (example of design).15

PROCESS DESCRIPTION18

FLEXITHERM™-FB working principle18

FLEXITHERM™-FB description.19

FLEXITHERM™-VB/VM working principle.21

FLEXITHERM™-VB/VM control philosophy23

FLEXITHERM™-VB/VM description25

CONTROL PANEL27

Denominations27

Operator panel28

Main picture31

Operation picture32

Beer type production picture32

Service picture33

Date & time picture.33

Beer type service picture34

Controller picture34

Supervision of fault.35

Fault list36

Emergency stop36

Start after emergency stop.36

OPERATION37

Preparations37

Start-up/sterilization38

Production	40
Circulation	41
Emptying	42
Stabilize/Shut down	43
Tank sterilization (if applicable)	44
Tank production (if applicable)	45
Tank emptying (if applicable)	47
Tank drain (if applicable)	48
CLEANING	49
SETTINGS	51
Inspection/change of register value(s)	51
Selection of beer type	53
Selection of PU/Fixed temperature	55
Selection of Auto/Min/Fixed flow (only if -VB/VM)	56
Changing beer type set points	57

General information



To ensure maximum safety, always read the “Safety instructions” and relevant instructions before carrying out any work or inspection on the equipment.

Service

In case of problems when operating the module, contact the nearest Alfa Laval company.

Manufacturer

Alfa Laval Copenhagen A/S
 Maskinvej 5
 DK-2860 Søborg/Copenhagen
 DENMARK

Name plate

The plate below is an example of the attached plate. The plate contains the data needed when contacting Alfa Laval Copenhagen A/S concerning this particular module.

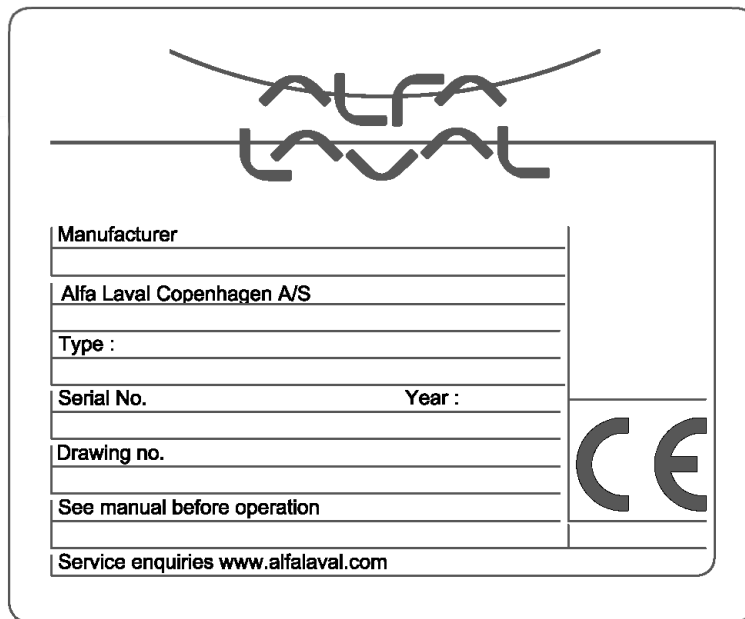

Product documentation

The documentation for this module consists of a TECHNICAL DOCUMENTATION on CD as outlined in the table of contents.

This OPERATION MANUAL is enclosed as a part of the TECHNICAL DOCUMENTATION. The OPERATION MANUAL is intended to be placed at the operator panel in order to at all times provide the operator with guidance and information on how to operate the module. As a consequence of this, certain parts of the different sections are repeated.

It is important to:

- Keep the manuals available and updated for the life of the module
- Pass the manuals on to any subsequent holder or user of the module

Abbreviations

Abbreviations as follows may be used in this documentation.

CIP	Cleaning In Place
Cl ₂	chlorine
CO ₂	carbon dioxide
Cu	copper
DO	Dissolved Oxygen
Fe	iron
HE	Heat Exchanger
HNO ₃	nitric acid
I/O	In/Output module
K	potassium
KMnO ₄	potassium permanganate
Na	sodium, sodium
N ₂	nitrogen
NaOH	sodium hydroxide (caustic soda)
NO ₂	nitrogen dioxide, nitric dioxide
O ₂	oxygen
pH	determination of acid/base concentration
PBT	Pasteurized Beer Tank
PHE	Plate Heat Exchanger
PLC	Programmable Logic Controller
PU	Pasteurizing Unit

Design modifications

The directives in this documentation are in accordance with the design and construction of the module at the time it was released by the Alfa Laval production facility.

Safety instructions



To ensure maximum safety always read this section carefully before carrying out any work or inspection on the equipment. If the safety instructions are not followed, there is a risk of personal injury.

Use of hazard informations

Hazard informations in this documentation have the following significance:



DANGER!

Failure to observe this information results in immediate danger to life.



WARNING!

Failure to observe this information may result in major personal injury or loss of life.

Caution!

Failure to observe this information may result in minor personal injury or damage to the equipment.

Note!

Information requiring special emphasis.

Use of signs

Warning signs are used as below.



Corrosive

Substances that may be harmful to body tissues. Do not touch without proper protection.



Hot surface

Temperatures exceeding 60°C may occur. Do not touch without proper protection.



Electrical risk

An electric shock can injure or kill. Treat all electrical equipment as powered. Switch off power before maintenance or repair.



High noise levels

Noise levels exceeding 85 dBA may occur. Use hearing protection.



Safety helmet

Risk of falling objects or of knocking into things.



Safety shoes

Risk of foot injuries due to falling or rolling objects, or objects piercing the sole, or electrical hazard, such as a static discharge or electric shock hazard.



Eye protection

Risk of eye injuries due to risk of splashing liquids or chemicals, or by dust or other flying particles.



Safety gloves

Risk of burns when handling chemicals, or electrical shock.

Cleaning solution



WARNING! Handling of cleaning solution

Cleaning solution normally contains caustic soda (NaOH) or nitric acid (HNO₃). These chemicals may cause burning of body tissues. Follow the instructions given by the supplier.

Whenever there is a risk of exposure to these chemicals, always wear:

- Safety glasses
- Safety gloves
- Safety shoes and apron made of PVC/PE plastic, or rubber

In case of an accident involving cleaning solution, the basic rule is to, as soon as possible, rinse the affected area with large amounts of water.

Due to this, always make sure that the emergency and eye showers, and also additional washing facilities are ready for use.

Emergency measures

If swallowed

- immediately drink large amounts of lukewarm water (to dilute what has been swallowed), then seek medical attention

If contact with eyes

- immediately rinse the eyes thoroughly with lukewarm water at least 15 minutes (keep eyelids widely apart), then seek medical attention

If contact with skin or clothes

- immediately remove contaminated clothing
- immediately rinse with large amounts of water. If skin burns appear, seek medical attention
- thoroughly wash the clothing before worn again

If inhaled

- leave the affected area to get fresh air. If any symptoms remain, seek medical attention

Note! Reaction may occur several hours after inhalation.

Gas



WARNING! This module uses carbon dioxide (CO₂) or, if applicable, nitrogen (N₂). These gases displace air and thus obstruct oxygen from entering the respiratory organs. High concentration creates lethal danger. Follow the instructions given by the supplier.

General description

Application

FLEXITHERM™ is a pre assembled skid mounted module for pasteurization of beer and carbonated products. It offers accurate control of the pasteurization parameters to ensure uniform treatment of the product.

The FLEXITHERM™ capacity is automatically adjusted as a result of variations in the filling machine demand, which can be due to breaks in the filling operation or changeover to other size of packages etc.

Requirements on personnel

Operator:

Trained in food/brewery processing and process controllers.

CAUTION! Unauthorized personnel

Operation by unauthorized personnel may endanger personnel and property.

Operator station

In front of the control panel.

Risk area

One meter around the equipment due to jets/splashes of harmful liquid

Risk area:

One meter around the equipment.

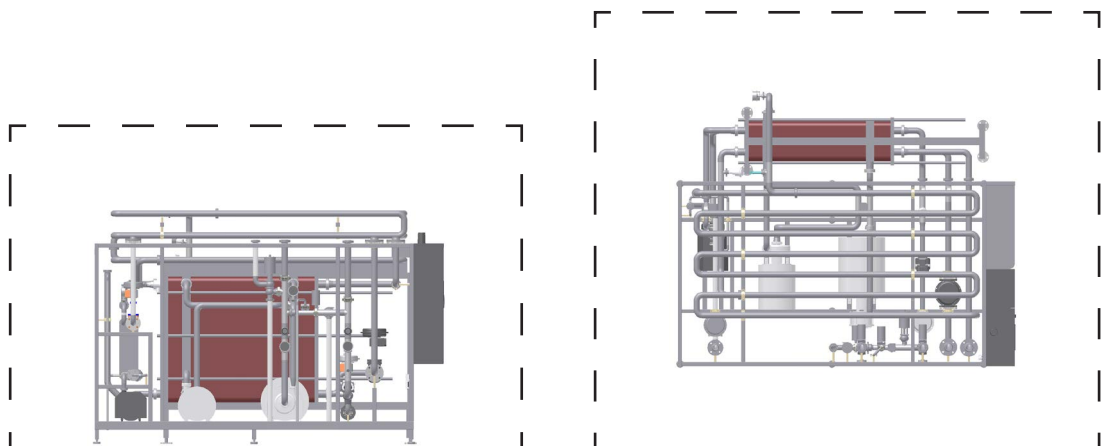

Principle layouts

1. Plate heat exchanger for product
2. Holding cell
3. Control panel
4. Pumps
5. Control/regulating valve(s)
6. Flow meter
7. Frequency converter (optional)

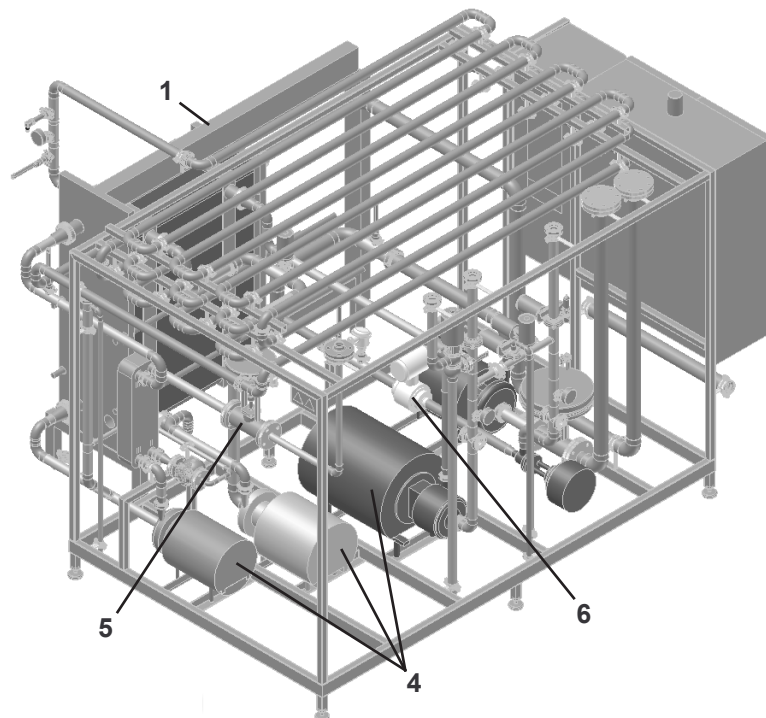
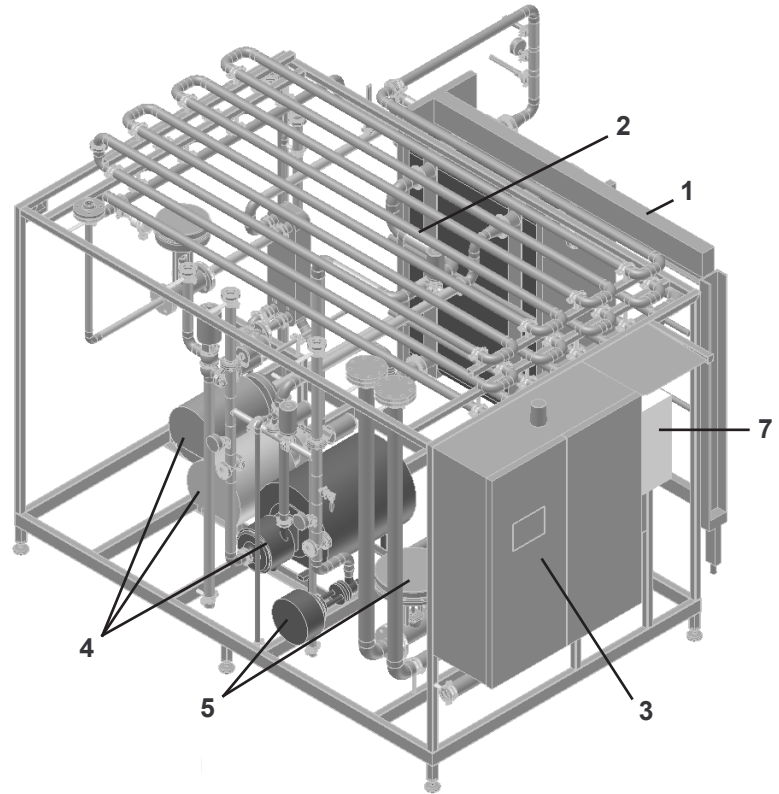

Denominations (example of design)

Control panel

The control panel contains all equipment necessary for indication of process status, supervision of process performance, and control of automatic functions.

The FLEXITHERM™ automation is based on a PLC.

The controller features:

- Process sequence control
- Timers
- Control loops
- Graphic display
- Alarm handling



Heat exchanger for product

The product is heated and cooled in the heat exchanger, which has been specially designed for high pressure applications. For the working pressure, see tags **Technical Data** and **Heat Exchanger**. The plates in the heat exchanger are designed for maximum heat transfer and minimum pressure drop.

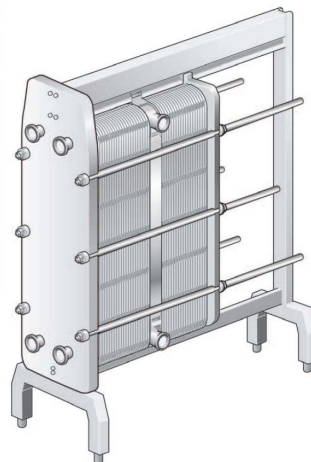

Controlling/regulating valve

Sanitary electro-pneumatic modulating valve(s) controls/regulates the flow(s).

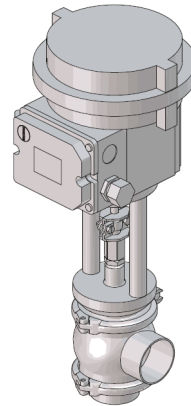
**Flow meter**

The flow is measured with electromagnetic flow meter. These instruments measure accurately, are wear free and corrosion resistant, cause no additional pressure drop, and have no moving parts or parts which intrude into the meter tube.

**Centrifugal pump**

The product pump is a centrifugal pump capable of delivering high pressure. This high pressure is essential for keeping the CO₂ in solution at the pasteurization temperature.

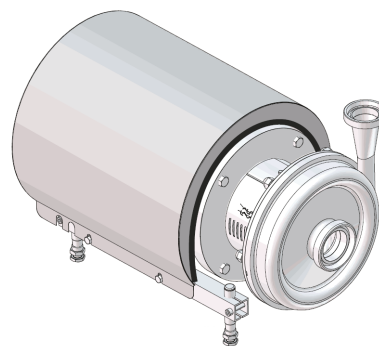

Holding cell

The holding cell is used to hold the product at the pasteurizing temperature for the time specified.

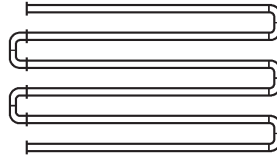
**Heat exchanger for hot water**

Hot water is generated with low pressure steam in a heat exchanger. The generated hot water is circulated through the main HE for product thus gently bringing the product to the required pasteurization temperature.



Process description

FLEXITHERM™-FB working principle

The purpose of FLEXITHERM™ is to pasteurize beer by heating it for a short time.

The pasteurizing effect is measured as PU (pasteurizing units), and is calculated from the formula below.

The PLC controls the module operation, and ensures constant pasteurizing effect. The operator simply selects the required pasteurizing temperature/PU value or beer type.

$$PU = t/60 \times 1.393^{(T-60)}$$

where

t = holding time (which is inversely proportional to the flow)

T = holding temperature

Example 1

FLEXITHERM™ with a capacity of 120 hl/h and a 100 liters holding cell.

Flow 120 hl/h = 3.33 l/second

This gives a holding cell time = 100/3.33 = 30 seconds.

Holding temperature T = 72°C

$$PU = 30/60 \times 1.393^{(72-60)} = 26.6$$

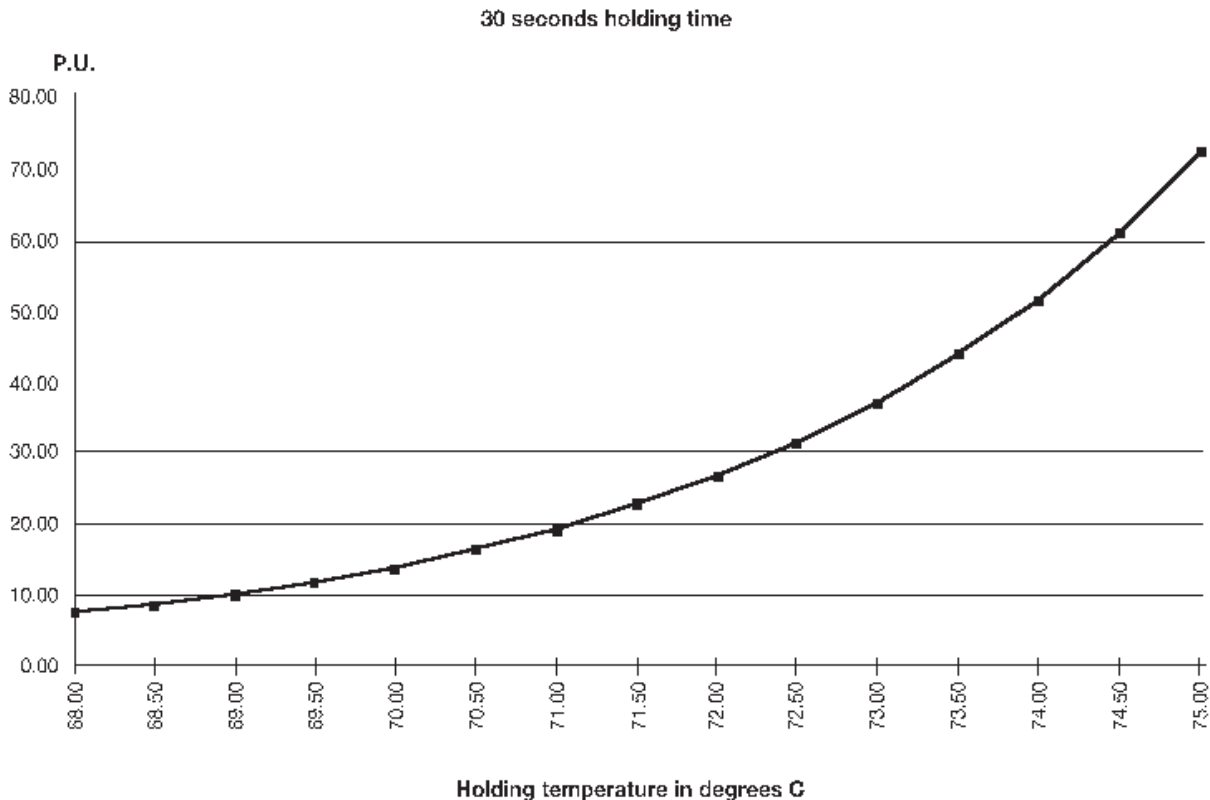

FLEXITHERM™-FB description

Beer is pasteurized in the module by heating it up to pasteurizing temperature and holding it for a given time.

The incoming product is pumped to the regenerative section of the plate heat exchanger (PHE) before final heating by hot water in the heating section. The temperature difference between the product and the hot water is kept as low as possible.

The beer pressure is increased by a booster pump (optional) placed between the regenerative and the heating section. This is to ensure that the pasteurized product pressure is at all points higher than the unpasteurized product pressure.

Holding of the product for the specified period at the pasteurization temperature is carried out in the holding cell. Cooling is carried out first regeneratively in the second section of the PHE and then by a cooling medium in the cooling section of the PHE (if applicable).

The pasteurizer throughput is set to a fixed value. This flow rate together with the pasteurization provides the corresponding PU effect to the product.

Sterilization

The pasteurizer is filled with water. When the system is filled, the water is circulated and heated. When the sterilization temperature is reached, circulation will continue for a preset time. After this time the circulating water is cooled down. The module is now Ready for production.

Product filling

Product enters the system via the inlet line while purging the water in the system to drain or recovery. When the system is filled with product the route is opened into the tank or filler.

Production

The product enters the module, and is pasteurized. The PU effect is maintained constant by adjusting the pasteurizing temperature.

Emptying

The product supply is stopped and water is taken into the module. The product is purged to the tank or filler until the system is filled with water. The outlet is then diverted to drain or recovery to rinse out the module. After a time the module will go to recirculation mode, and the module is Ready for production again.

Cleaning

Sterilization must be performed every day prior to production. Also the system should be cleaned with caustic soda once a day (depending on product). Acid cleaning should be done once a month to avoid deposits building up on the stainless steel surfaces.

The cleaning sequences and solutions are controlled from an external CIP module. The FLEXITHERM™ receives commands to open the route and provide heating of the CIP solutions if requested. A number of valves in the module are automatically flipped intermittently, in order to clean the seal areas of these valves.

Note! For a more detailed description of the different process steps, see **Basic Process Description**.

Note! The below flowchart is an example and may vary depending on the design.

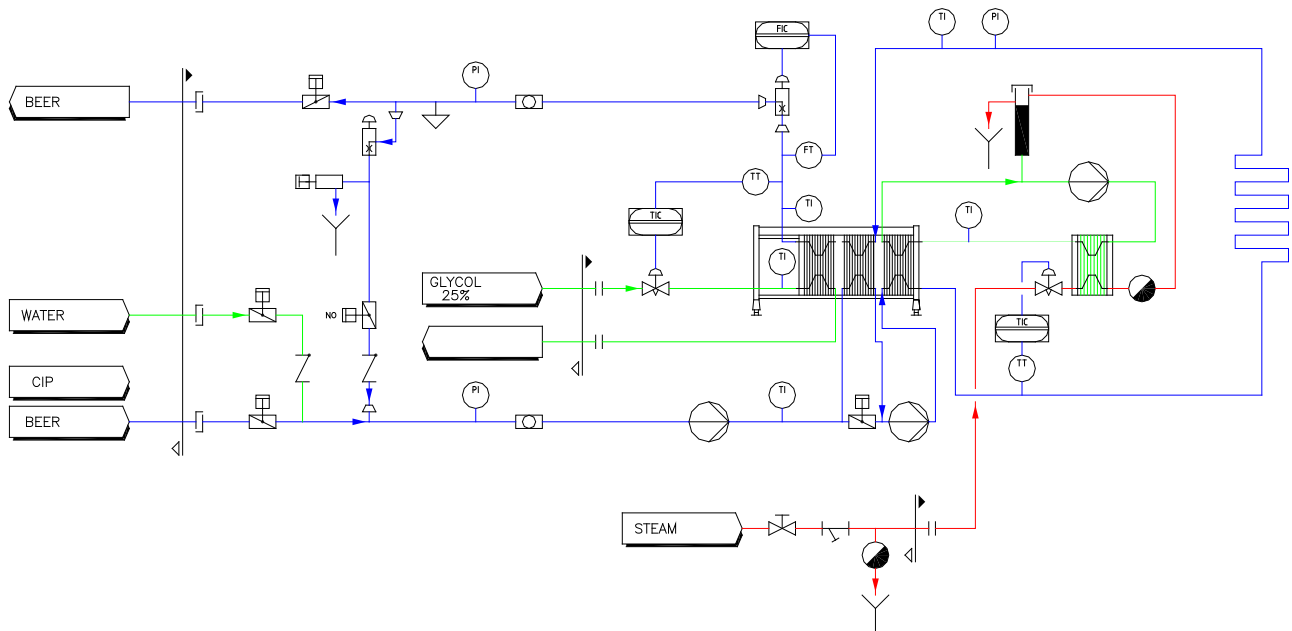

FLEXITHERM™-VB/VM working principle

By utilizing a pasteurized beer buffer tank, circulation of the beer is avoided and over-pasteurization does not occur. This is achieved by monitoring the level in the pasteurized beer tank. If the filler capacity decreases, the level in the tank will increase and the FLEXITHERM™ flow rate will be reduced accordingly. The PU level is proportional to the holding time which is inversely proportional to the flow. It is therefore necessary to adjust the pasteurization temperature, in order to maintain a constant PU level.

The PLC controls the module operation, and ensures constant pasteurizing effect. The operator simply selects the required PU value or beer type.

The FLEXITHERM™ basic function is to maintain constant PU dose in the product, irrespective of variations in the flow. The PU dose is based on the following formula:

$$PU = t/60 \times 1.393^{(T-60)}$$

where

t = holding time (which is inversely proportional to the flow)

T = holding temperature

Example 1

FLEXITHERM™ with a capacity of 120 hl/h and a 100 liters holding cell.

Flow 120 hl/h = 3.33 l/second

This gives a holding cell time = $100/3.33 = 30$ seconds.

Holding temperature T = 72°C

$$PU = 30/60 \times 1.393^{(72-60)} = 26.6$$

Example 2

The same FLEXITHERM™ (100 liters holding cell), but the flow is reduced to 60 hl/h.

Flow 60 hl/h = 1,667 l/second

This gives a holding cell time = $100/1.667 = 60$ seconds

$$PU = 60/60 \times 1.39^{(72-60)} = 53.4$$

That is, if the holding temperature is constant and the flow rate reduced, the PU-effect is increased.

Example 3

In order to maintain a constant PU we need to reduce the holding temperature to compensate for the longer holding time. We require 30 PU at a flow rate of 60 hl/h, the equivalent holding time for a holding cell of 100 liters is 60 seconds (see previous example). What is the required holding temperature?

PU = 30

t = 60 seconds

$$30 = 60/60 \times 1.393^{(T-60)}$$

$$\ln 30 = (T-60) \times \ln 1.39$$

$$3.40 = T \times 0.33 - 19.8$$

$$T = 23.29/0.33 = 70.3^{\circ}\text{C}$$

From the examples above it is understood how varying the flow rates effects the PU dose. To compensate for this we adjust the holding cell temperature accordingly. This ensures gentle product treatment and constant beer stability.

FLEXITHERM™-VB/VM control philosophy

If not “fixed temperature” has been selected, the basic function is to maintain a constant PU dose in the product.

The current level in the pasteurized beer tank (PBT) is used to determine the required capacity. This capacity is then used to calculate, via the PU formula, a new heating temperature set point. From the current heating temperature and the selected PU value the capacity setpoint is calculated.

The current heating temperature and capacity are then used to calculate the current PU dose and monitor the deviation, if any, for alarm purposes.

Note! The below flowchart is an example and may vary depending on the design.

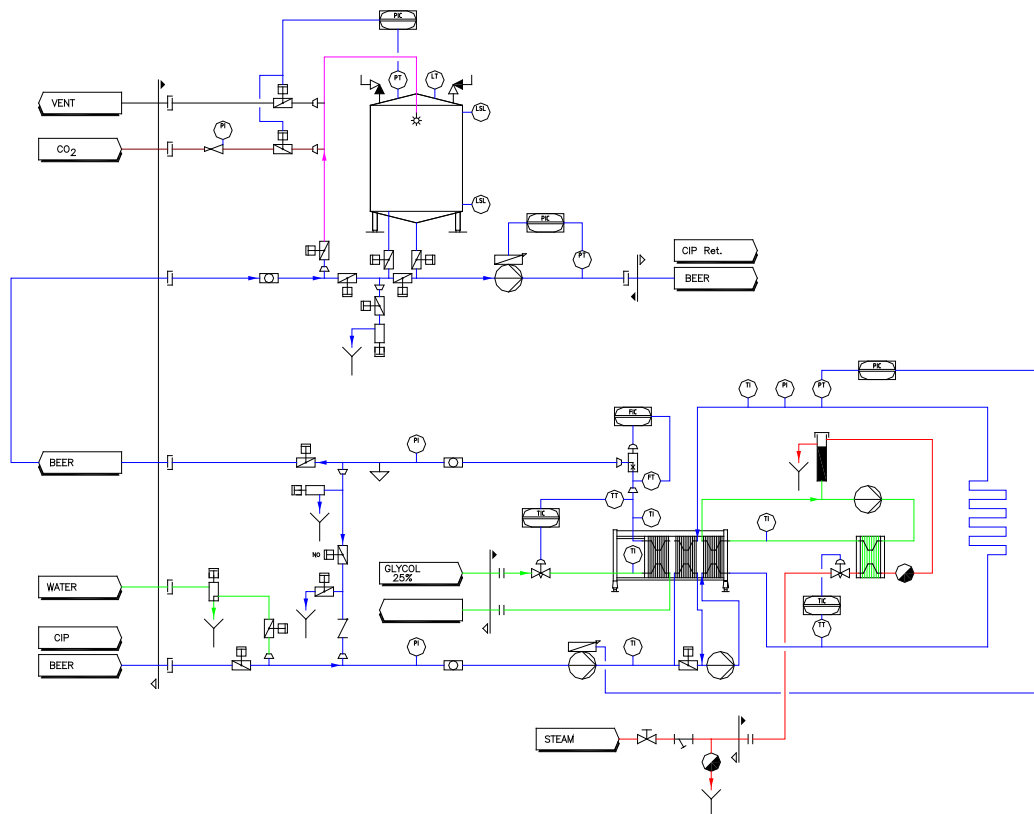

30 seconds holding time

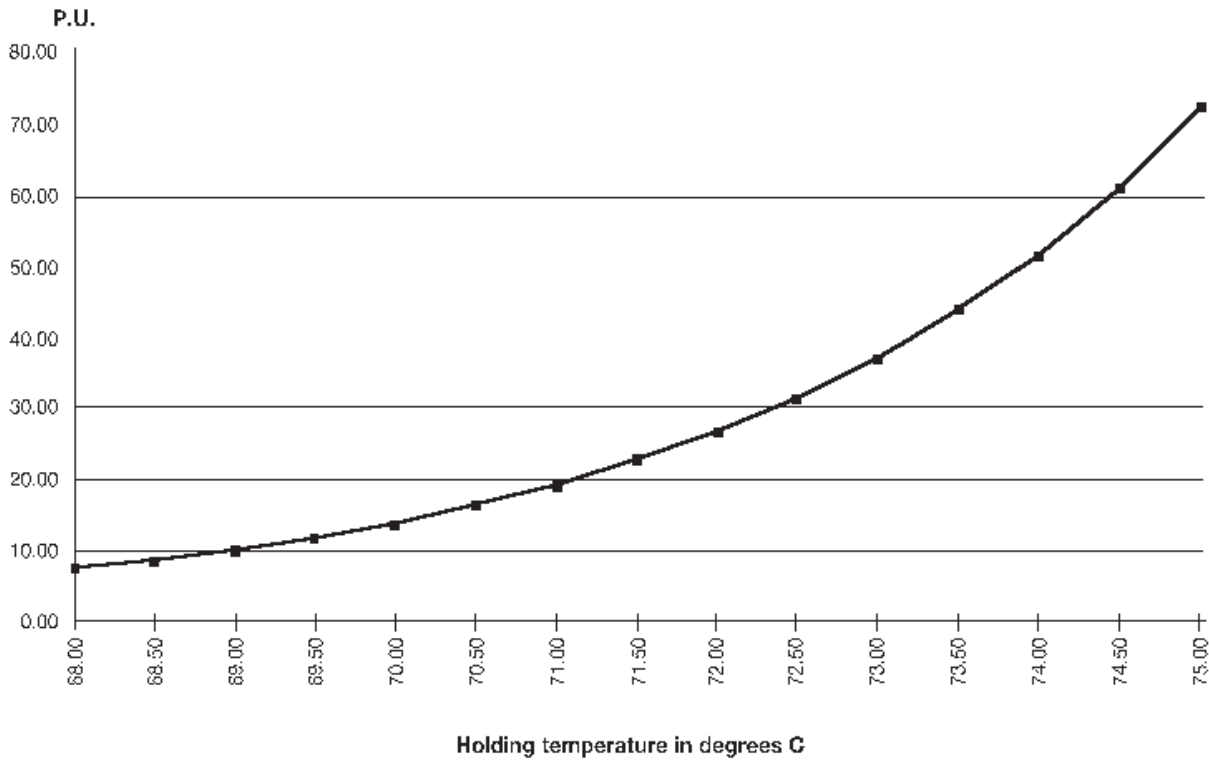

60 seconds holding time

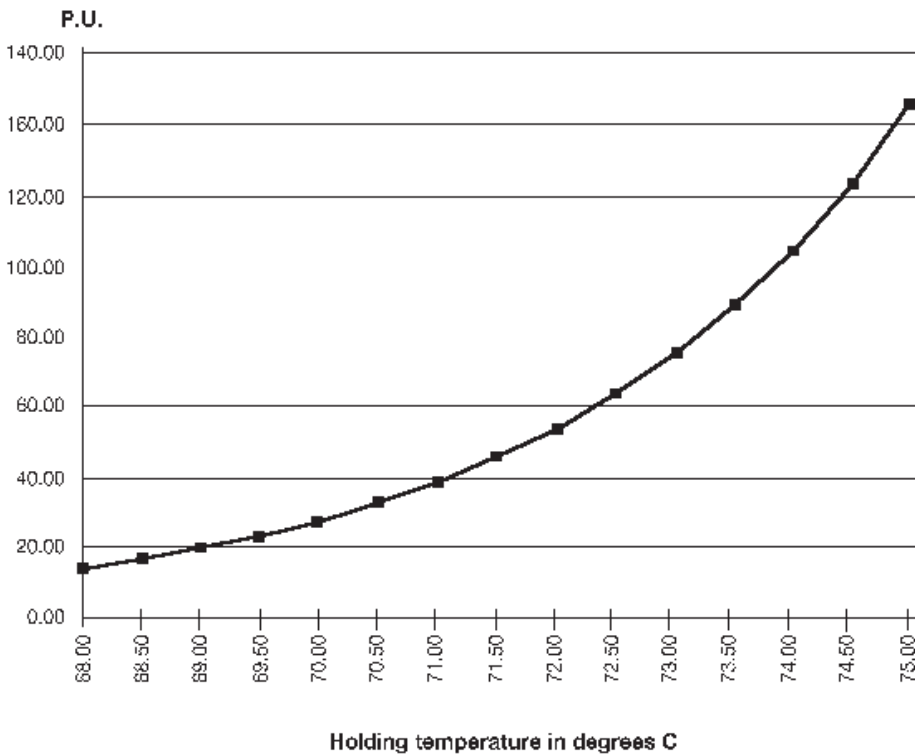

FLEXITHERM™-VB/VM description

Beer is pasteurized in the module by heating it up to pasteurizing temperature and holding it for a given time.

The incoming product is pumped to the regenerative section of the plate heat exchanger (PHE) before final heating by hot water in the heating section. The temperature difference between the product and the hot water is kept as low as possible.

The beer pressure is increased by a booster pump (optional) placed between the regenerative and the heating section. This is to ensure that the pasteurized product pressure is at all points higher than the unpasteurized product pressure.

Holding of the product for the specified period at the pasteurization temperature is carried out in the holding cell. Cooling is carried out first regeneratively in the second section of the PHE and then by a cooling medium in the cooling section of the PHE (if applicable).

The pasteurizer capacity will vary according to the level in the buffer tank. If the level in the tank rises above the set level (for example due to a stop in the filling operation) the capacity of the pasteurizer will be decreased. Conversely if the level in the buffer tank drops below the set level, the pasteurizer capacity will be increased.

By means of these step less capacity adjustments, the level in the buffer tank is maintained around a constant level. However, should the level increase until high level is reached (e.g. due to very long filler stop), the remaining product in the pasteurizer will be purged to the buffer tank by water. Thereafter the pasteurizer goes into recirculation on water. This ensures that no recirculation of product is necessary.

Sterilization

The pasteurizer is filled with water. When the system is filled, the water is circulated and heated. When the sterilization temperature is reached, circulation will continue for a preset time. After this time the circulating water is cooled down. The module is now Ready for production.

Product filling

Product enters the system via the inlet line while purging the water in the system to drain or recovery. When the system is filled with product the route is opened into the tank and the level in the tank begins to rise.

Production

The product enters the module and is pasteurized and stored in the buffer tank. From here it is fed through to the filling machine. The level in the tank is controlling the throughput of the pasteurizer. If the level tends to rise, the capacity will decrease. If the level tends to drop the throughput will increase. The PU effect is maintained constant by adjusting the pasteurizing temperature.

Emptying

The product supply is stopped and water is taken into the module. The product is purged to the tank or filler until the system is filled with water. The outlet is then diverted to drain or recovery to rinse out the module. After a time the module will go to recirculation mode, and the module is Ready for production again.

Cleaning

Sterilization must be performed every day prior to production. Also the system should be cleaned with caustic soda once a day (depending on product). Acid cleaning should be done once a month to avoid deposits building up on the stainless steel surfaces.

The cleaning sequences and solutions are controlled from an external CIP module. The FLEXITHERM™ receives commands to open the route and provide heating of the CIP solutions if requested. A number of valves in the module are automatically flipped intermittently, in order to clean the seal areas of these valves.

Note! For a more detailed description of the different process steps, see **Basic Process Description**.

Control panel

Denominations



The front of the control panel is equipped with the following equipment:

1. Mains switch
2. Emergency stop button
3. Emergency reset button
4. Operator panel (HMI)
5. Indication lamps

Red lamp for indication of alarm

- Flashing light indicate unacknowledged alarm
- Steady light indicate acknowledged alarm

Yellow lamp for indication of warning

- Flashing light indicate equipment in manual mode
- Steady light indicate general warning

Green lamp for indication of normal condition

- Indicates that a program/phase is running
- Flashing when CIP program/phase is running

Operator panel

The main parts of the pictures are as below.

Note! The following pictures are examples and may vary depending on type and options.

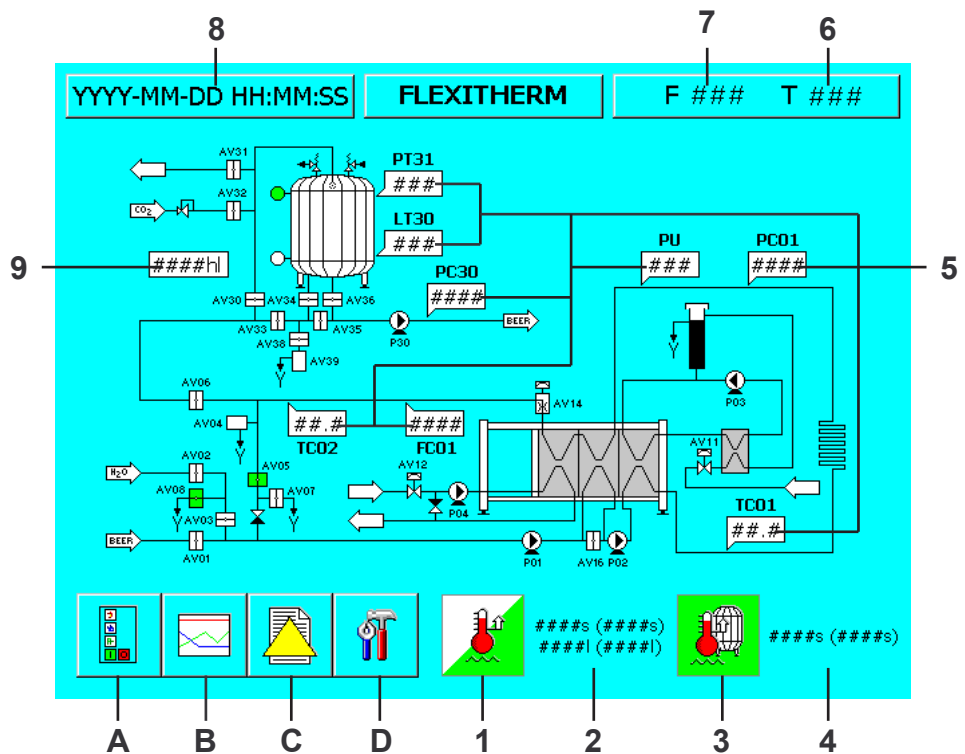

Display

1. Indication of the Flexitherm™ steps
 2. Time and/or volume in Flexitherm™ step (if applicable)
 3. Indication of the tank steps (if applicable)
 4. Indication of time in tank step (if applicable)
 5. Indication of present process value. When pressed, the controller is displayed (if applicable). If the controller is in manual mode the value is flashing.
 6. Indication of the tank step number (if applicable)
 7. Indication of the Flexitherm™ step number
 8. Indication of date and time
 9. Indication of accumulated volume in production, press to reset
- When a function is activated its symbol changes to green.

Push-buttons

- A. Displays the OPERATION picture
- B. Displays the TREND picture
- C. Displays the ALARM picture
- D. Displays the SERVICE picture

By pressing, for example, TC01 (Heating temperature controller) the controller picture is displayed.

Push-buttons

When a function is selectable, it appears as a push-button. If the function has been selected the background is green.



Selectable



Selected

Step symbols

Different color codes on the symbols indicate different status.

When a sequence is selected but not yet started the symbol background is white.

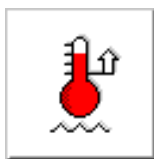

When the sequence is started but yet not active the background color is splitted diagonally, with the lower part green.



When the sequence is activated the background color changes to green.



Parameters

Parameters can be changed by pressing the desired parameter, which displays a numeric keypad. If a password/user name has to be entered (if applicable) this has to be entered first.



All steps are indicated with different symbols as below.

Flexitherm™

Tank (if applicable)

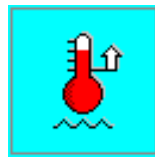

Sterilization

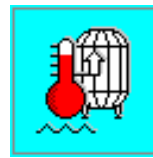

Sterilization

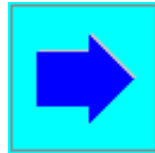

Production



Production

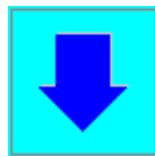

Emptying



Emptying

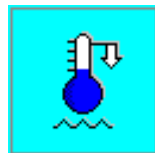

Stabilize

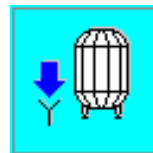

Drain

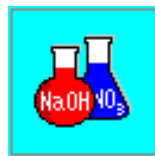

CIP

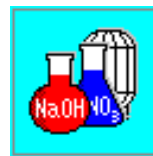

CIP



Circulation

Password/user name

There are three password/user name levels.

	Preset password	Preset user name
Level 1 Maintenance	1234	M
Level 2 Supervisor/Management	9999	S
Level 3 Alfa Laval Service	-	-

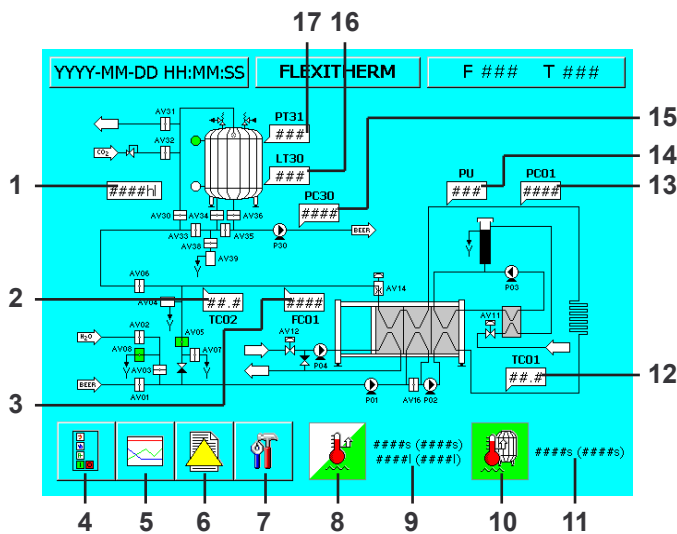

Main picture

When a valve or pump is activated the symbol changes to green.

1. Indication of accumulated volume in production, press to reset
2. Displays the cooling temperature controller
3. Displays the pasteurizer flow controller
4. Displays the OPERATION picture
5. Displays the TREND picture
6. Displays the ALARM picture
7. Displays the SERVICE picture
8. Indication of the Flexitherm™ steps
9. Indication of time and/or volume in Flexitherm™ step (if applicable)
10. Indication of the tank steps (if applicable)
11. Indication of time in tank step (if applicable)
12. Displays the heating temperature controller
13. Displays the holding cell pressure controller (if applicable)
14. Indication of the PU value
15. Displays the tank outlet pressure controller (if applicable)
16. Indication of the tank level (if applicable)
17. Displays the tank pressure controller (if applicable)

Operation picture

The functions inside the frame have to be confirmed, with either “1” to start or “0” to stop, within 10 seconds from pushing.

Tank (if applicable)

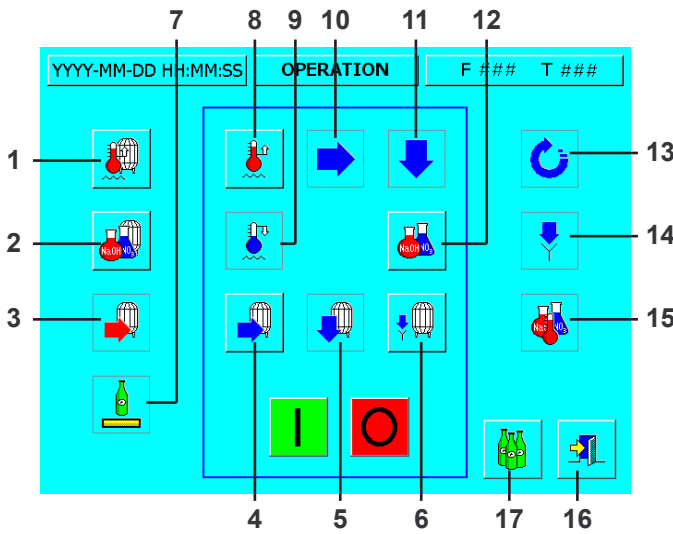

1. Sterilization
2. CIP
3. Production hold
4. Production
5. Emptying
6. Drain
- 15 Flexitherm™
7. Beer in beer line
8. Sterilization
9. Stabilize
10. Production
11. Emptying
12. CIP
13. Product circulation
14. Empty to drain
15. CIP Heating
16. Return to MAIN picture
17. To BEER TYPE PRODUCTION picture

Beer type production picture

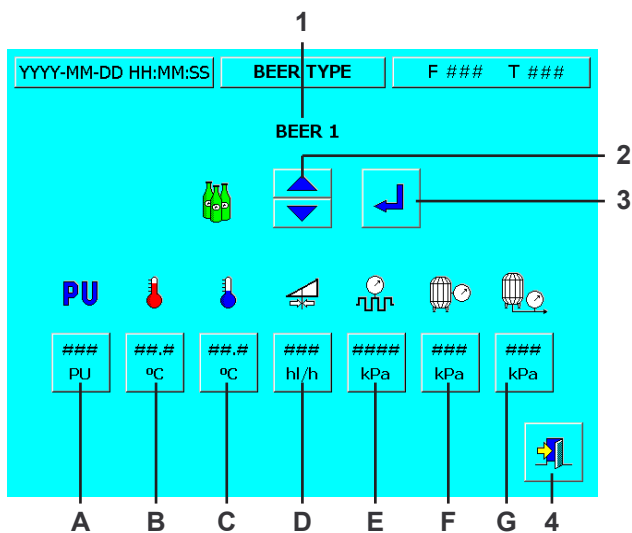

1. Indication of beer type for production
2. Beer type number count up or down
3. Selection of new beer type
4. Return to OPERATION picture

Setpoint selections

- A. PU value
- B. Pasteurization temperature
- C. Cooling temperature
- D. Fixed flow
- E. Holding cell pressure (if applicable)
- F. Tank pressure (if applicable)
- G. Tank outlet pressure (if applicable)

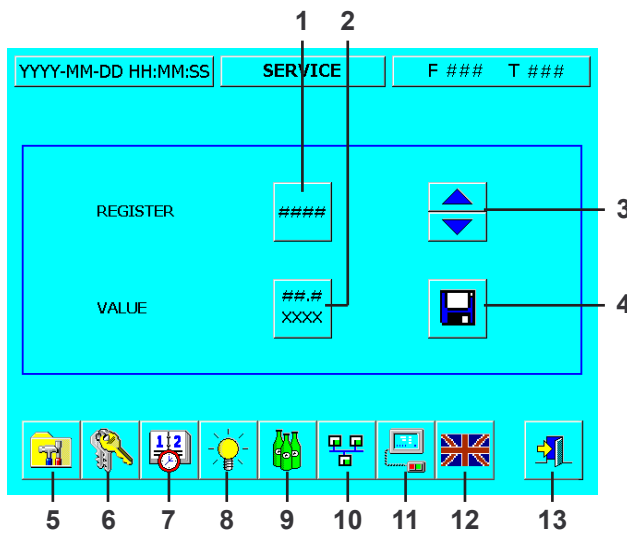

Service picture

1. Selection of register number
2. Indication of present register value
3. Register number, counting up or down
4. Saving of changes
5. Displays the CONTROL PANEL picture
6. Displays the PASSWORD picture
7. Displays the DATE & TIME picture
8. Lamptest
9. Displays the BEER TYPE SERVICE picture
10. Displays the COMMUNICATION SIGNALS picture (if applicable)
11. Selection of Local/Remote operation (if applicable)
12. Selection of different language (if applicable)
13. Return to MAIN picture

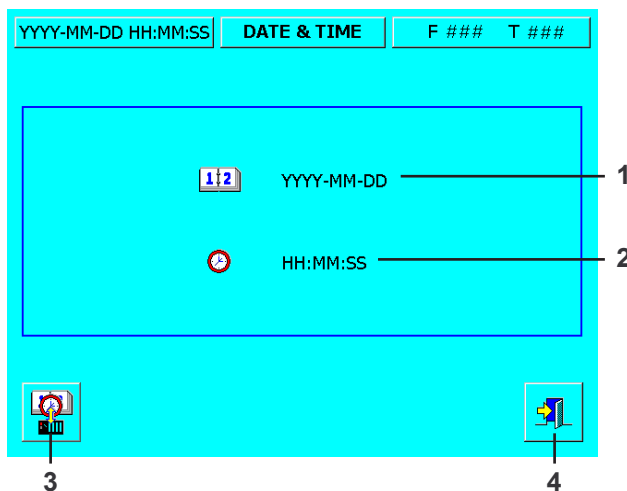

Date & time picture

1. Setting of new date
2. Setting of new time
3. Synchronize date/time between Touch Panel and PLC
4. Return to SERVICE picture

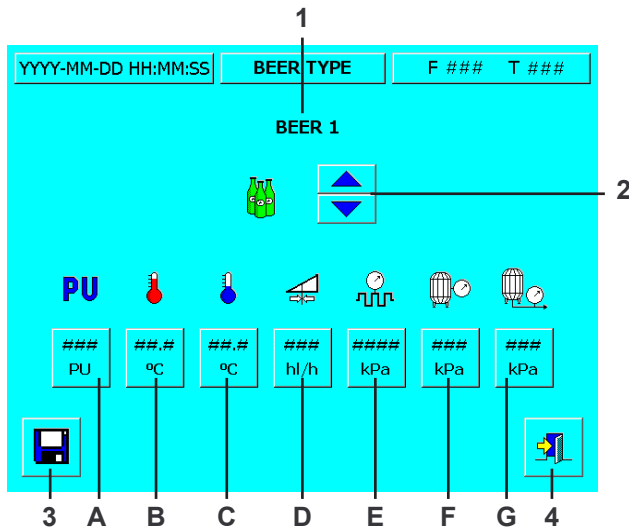

Beer type service picture

1. Beer type for service
2. Beer type number, counting up or down
3. Saving of changes
4. Return to SERVICE picture

Setpoint selections

- A. PU value
- B. Pasteurization temperature
- C. Cooling temperature
- D. Fixed flow
- E. Holding cell pressure (if applicable)
- F. Tank pressure (if applicable)
- G. Tank outlet pressure (if applicable)

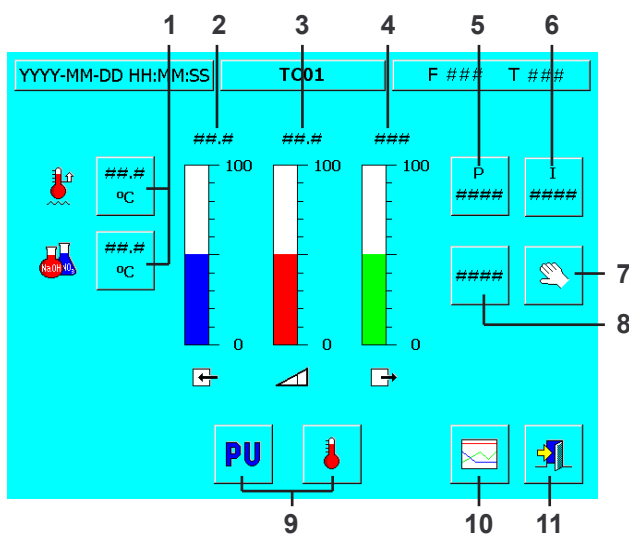

Controller picture

1. Selection of set points/limits
2. Bar graph and numeric display of the input signal (measured value)
3. Bar graph and numeric display of the setpoint
4. Bar graph and numeric display of the output signal
5. Selection of the gain
6. Selection of the I-time
7. Sets the controller in manual mode
8. Selection of the output signal, if in manual mode
9. Selection of running modes
10. Displays the controllers TREND picture
11. Return to MAIN picture

Supervision of fault

When a fault occurs, the signal lamp FAULT starts to flash and a fault window appears in the display.

When button ACKNOWLEDGE is pressed the FAULT lamp goes steady or is extinguished when the fault has disappeared.

By pressing the ALARM button the alarm list is displayed showing the last occurred faults. Each fault can be displayed three times with different codes.

- A. Active alarms
- C. Cleared alarms
- K. Acknowledged alarms

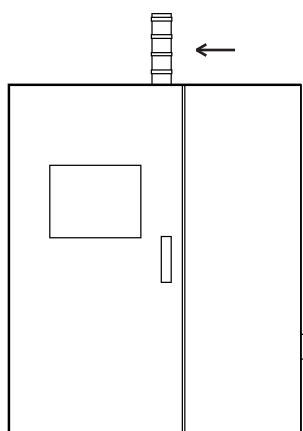

Caution! Fault indication

Always investigate the cause of a fault indication, or damage to the equipment may occur.

Fault list

Supervised faults can be found in the **Basic Process Description**. A list with preset values for timers etc., used to supervise the process is found in the **Parameter List**.

Note! Some of the listed faults belong to optional equipment and might not be applicable.

General causes of faults:

- No air supply to valves
- Solenoid valves not working
- Output signal on I/O unit not working
- I/O unit not working

CAUTION! **Unauthorized personnel**

Only authorized personnel are allowed to adjust or renew/repair equipment.

Note! For further details, see the **Maintenance, Trouble shooting chart**.

Emergency stop

In case of emergency, press the emergency stop button located on the control panel.

This stops the FLEXITHERM™ in the following way:

- Power supply for pump(s) is/are interrupted
- Valves take safe positions to avoid leakage
- Program goes to off stage



WARNING! The equipment may contain hot caustic liquid. Handle with utmost care to avoid exposure.

Start after emergency stop

- 1) Make sure the cause of the emergency is eliminated.
- 2) Release emergency stop button.
- 3) Press the emergency reset button.

Operation

Preparations

- 1) Check that required utilities are available.
 - Water pressure, open manual shut-off valve (if applicable)
 - Steam pressure, open manual shut-off valve (if applicable)
 - Coolant pressure, open manual shut-off valve (if applicable)
 - Air pressure, open manual shut-off valve (if applicable)
 - Electricity, switch on main supply
- 2) Check that the hot water circuit is filled.
- 3) Check/adjust the air pressure according to **Technical data**.

Note! The following screens are examples and may vary depending on type and options.

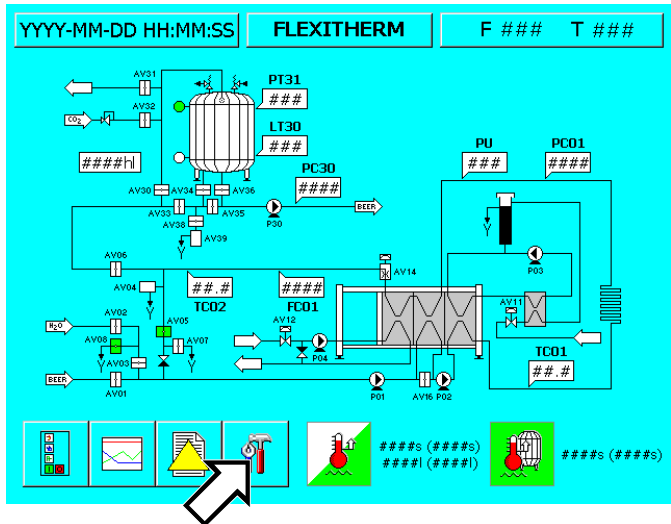

- 4) Perform a lamp test.
 - On the MAIN picture press the SERVICE button

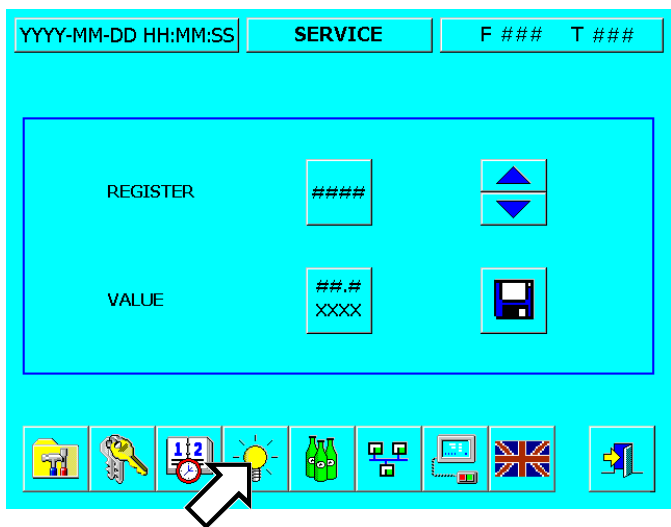

- 5) On the SERVICE picture, press the LAMP TEST button to perform the lamp test.

Note! Perform a lamp test at least once a day.

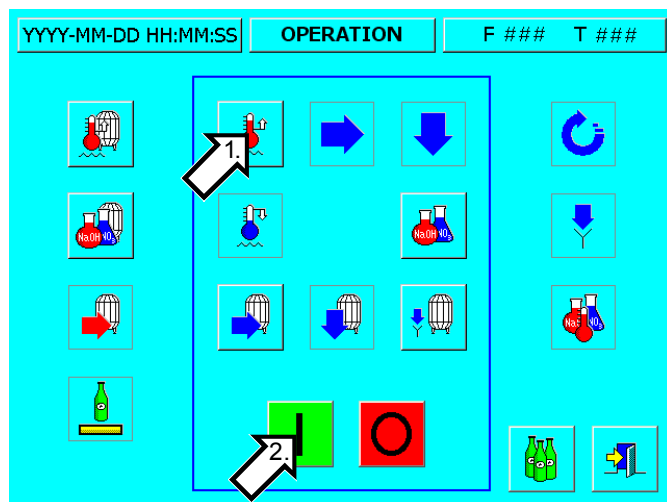

- 3) Start the sterilization by pressing the STERILIZATION button followed by the START button.
- 4) The FLEXITHERM™ is now being filled with water and starts heating the water. See **Basic Process Description** for explanation of the STERILIZATION operation.
- 5) When step 107 is reached the sterilization is completed.

Production

Before starting check that:

- The FLEXITHERM™ is in READY FOR PRODUCTION (step 107)
- Check that the set points are correct for the product in question
- Delivering tank(s) is/are ready
- Receiving tank/filler is/are ready
- No fault is displayed on the panel

If the OPERATION picture isn't displayed:

- 1) Press the OPERATION button on the MAIN picture.

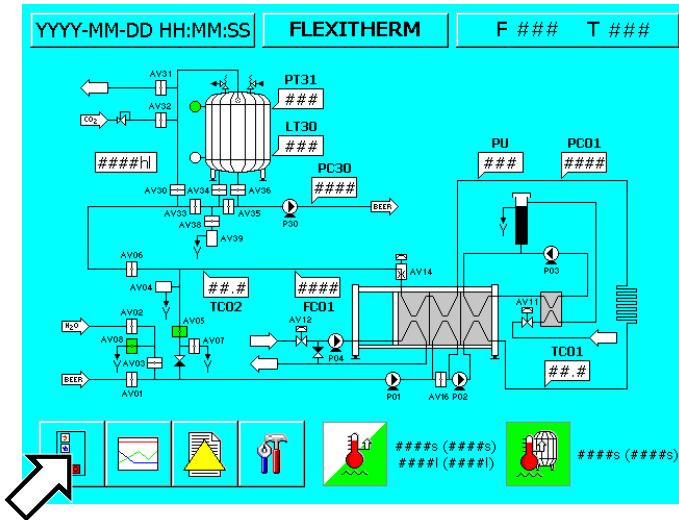

- 2) Start the production by pressing the PRODUCTION button followed by the START button.

- 3) The FLEXITHERM™ is now being filled with product purging the water in the system to drain. See **Basic Process Description** for explanation of the PRODUCTION operation.

- 4) When the filling operation is completed, and product is fed to the tank/filler, the PRODUCTION button background changes to green.

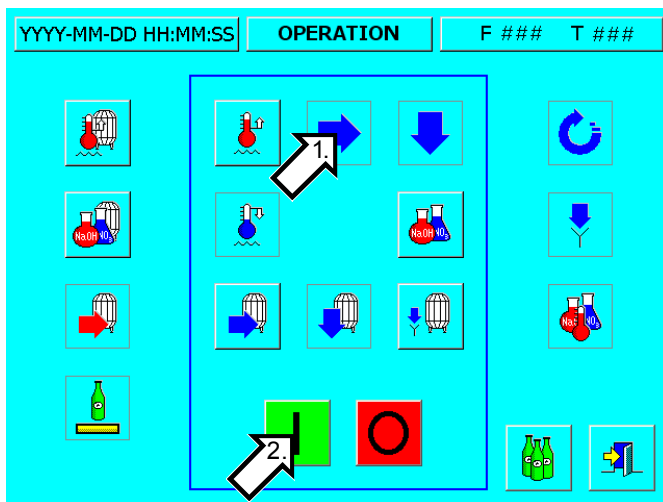

Emptying

Before starting, check that the FLEXITHERM™ is in PRODUCTION.

If the OPERATION picture isn't displayed:

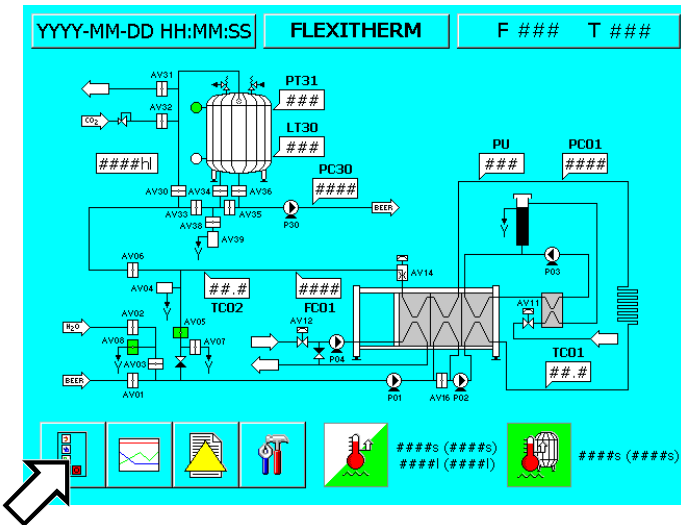

- 1) Press the OPERATION button on the MAIN picture.

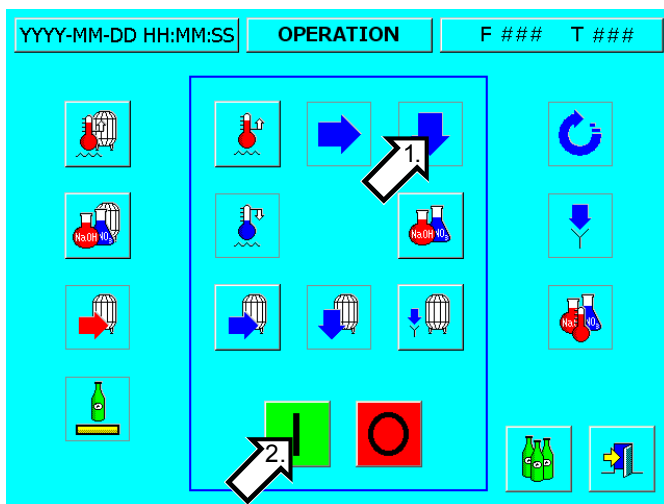

- 2) Select emptying by pressing the EMPTYING button followed by the START button.

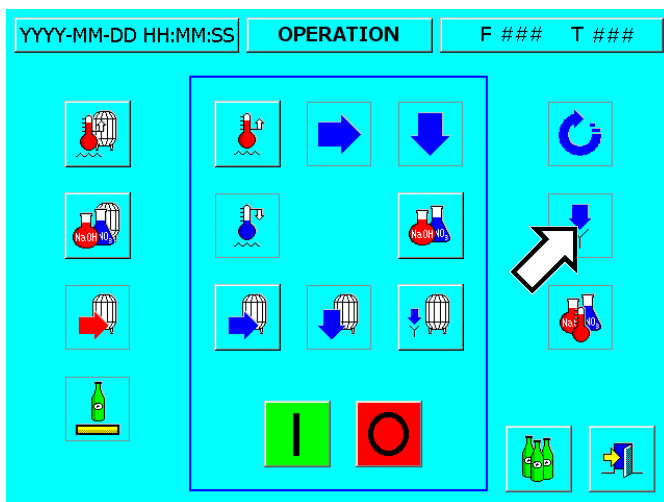

- 3) If the pasteurizer is to be emptied to drain, press the EMPTY TO DRAIN button before selecting emptying.
- 4) The FLEXITHERM™ is now being filled with water purging the product in the system to the tank/filler. See **Basic Process Description** for explanation of the EMPTYING operation.
- 5) When the emptying operation is completed, the system again is ready for production.

Stabilize/Shut down

Before starting, check that the FLEXITHERM™ is in READY FOR PRODUCTION.

If the OPERATION picture isn't displayed:

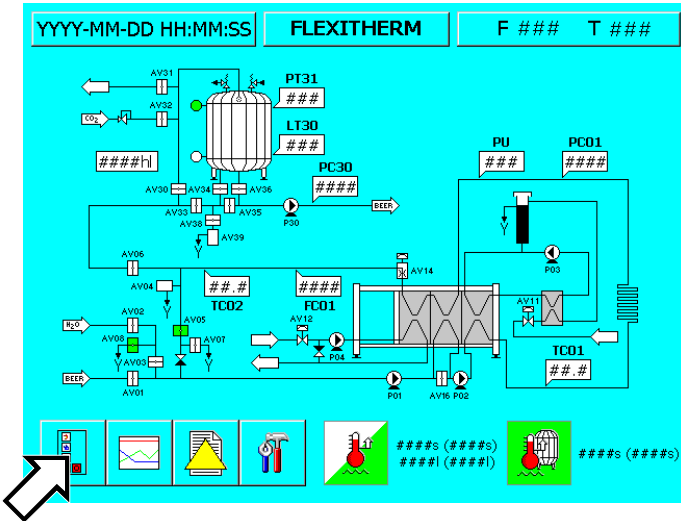

- 1) Press the OPERATION button on the MAIN picture.

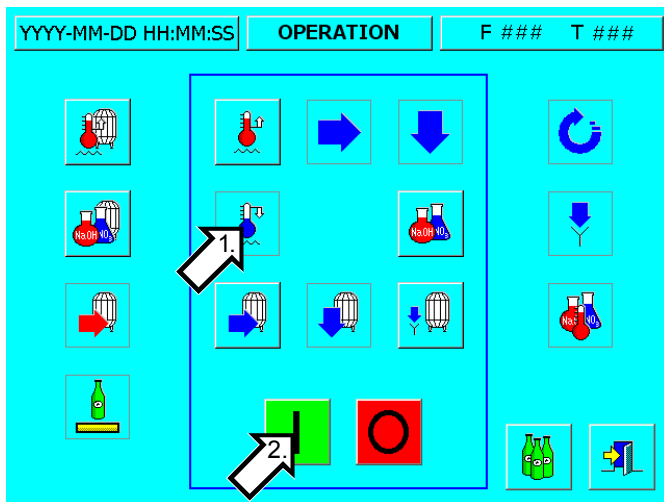

- 2) Select the stabilize/shut down by pressing the STABILIZE button followed by the START button.
- 3) Heating and cooling is shut off and the water in the system is circulated for a certain time (to equalize temperatures).
- 4) Pumps stop and valves return to deactivated positions.
- 5) Close all manual shut-off valves.

Tank production (if applicable)

Before starting check that:

- The FLEXITHERM™ is in PRODUCTION (step 205)
- Receiving filler is ready

If the OPERATION picture isn't displayed:

- 1) Press the OPERATION button on the MAIN picture.

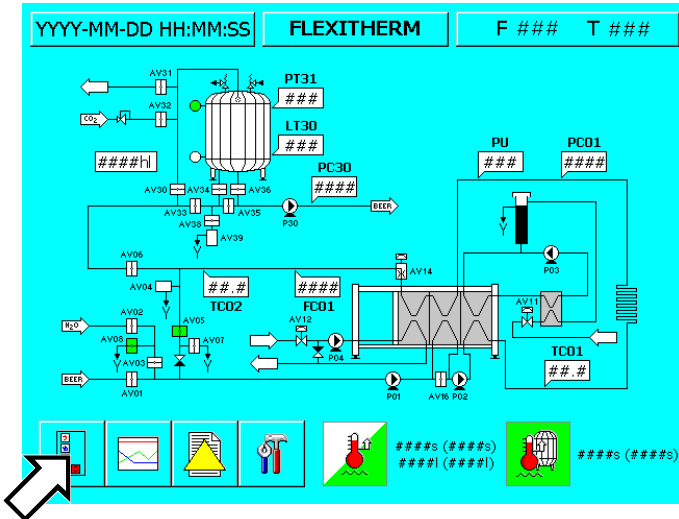

- 1) Press the OPERATION button on the MAIN picture.

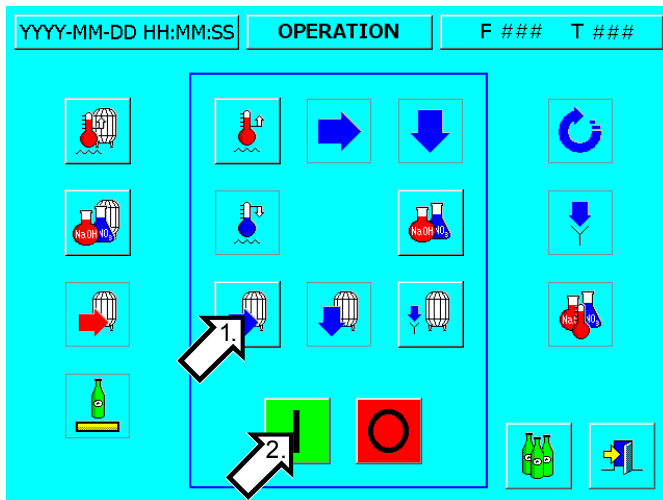

- 2) Start the production by pressing the TANK PRODUCTION button followed by the START button.
- 3) When the production level is reached the route to the filling machine is opened. See **Basic Process Description** for explanation of the TANK PRODUCTION operation.

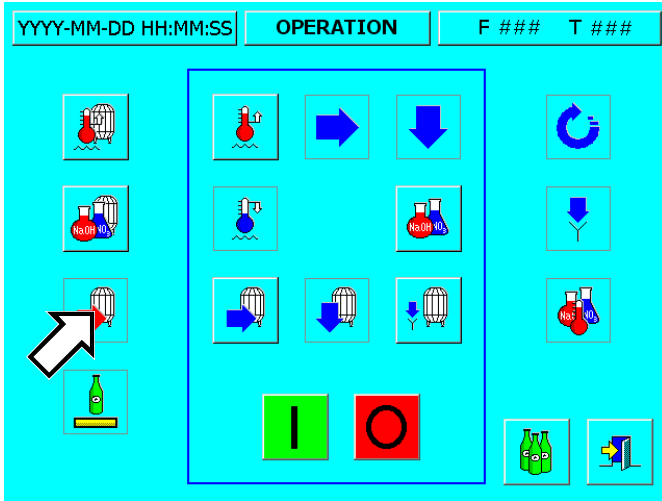

4) The tank production can be held temporarily by pressing the TANK HOLD button.

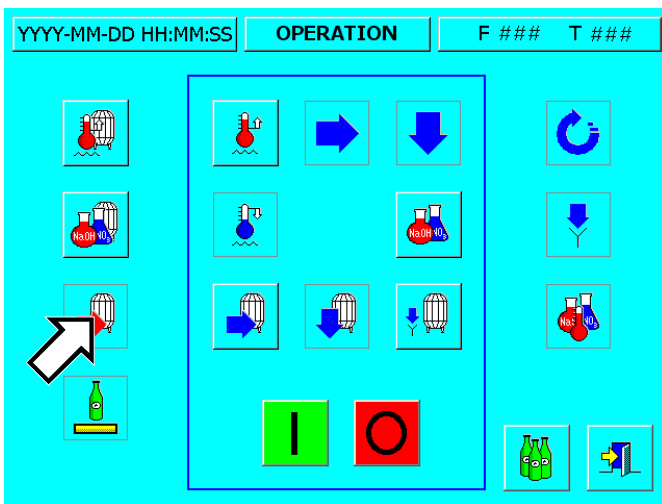

5) The tank will stay in HOLD until the TANK HOLD button is pressed again.

Tank emptying (if applicable)

Before starting check that:

- The tank is in PRODUCTION (step 202)
- Receiving filler is ready

If the OPERATION picture isn't displayed:

- 1) Press the OPERATION button on the MAIN picture.

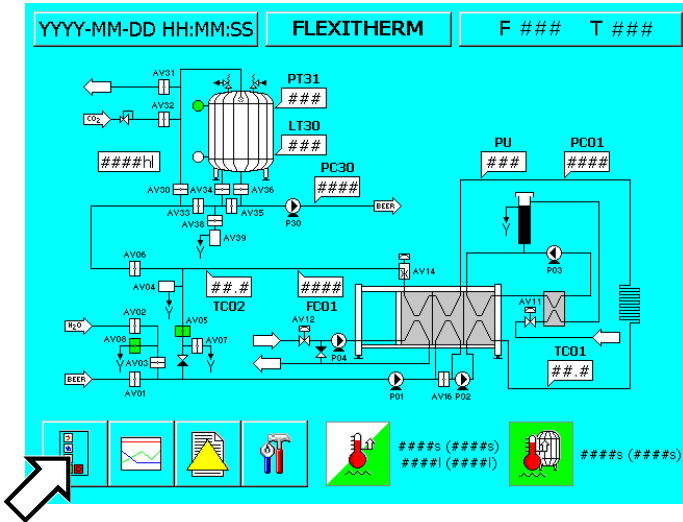

- 2) Start the emptying by pressing the TANK EMPTYING button followed by the START button.

- 3) When low level is reached and the preset time has elapsed, the pump (if any) stops and the valves return to deactivated positions. See **Basic Process Description** for explanation of the TANK EMPTYING operation.

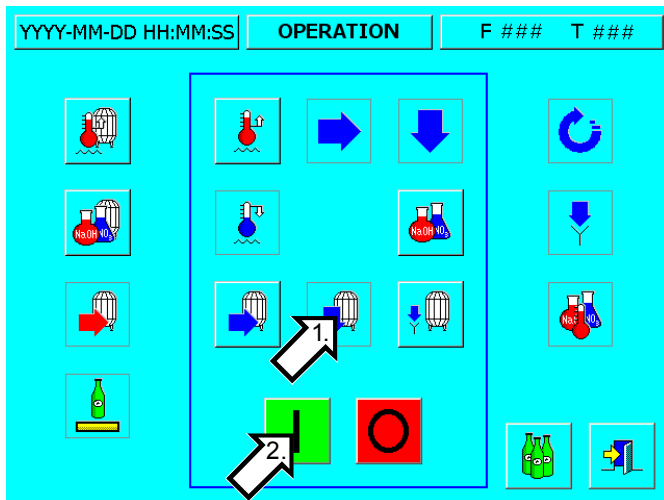

Tank drain (if applicable)

Before starting check that:

- The FLEXITHERM™ isn't in PRODUCTION
- The tank is in OFF

If the OPERATION picture isn't displayed:

- 1) Press the OPERATION button on the MAIN picture.

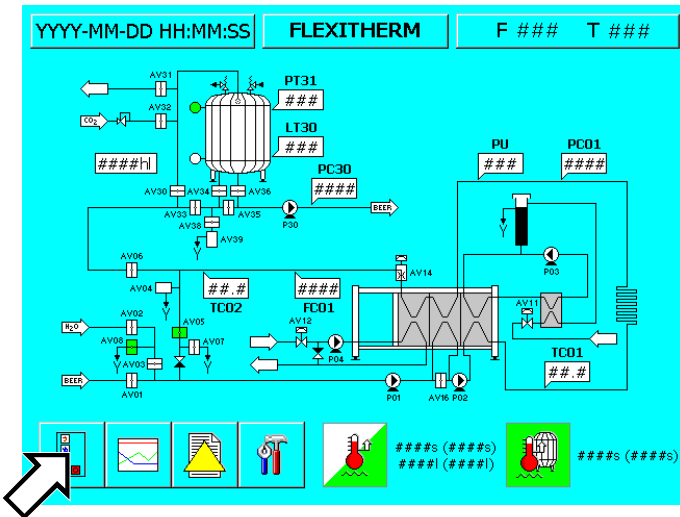

- 2) Start the draining by pressing the TANK DRAIN button followed by the START button. The route to drain is opened.

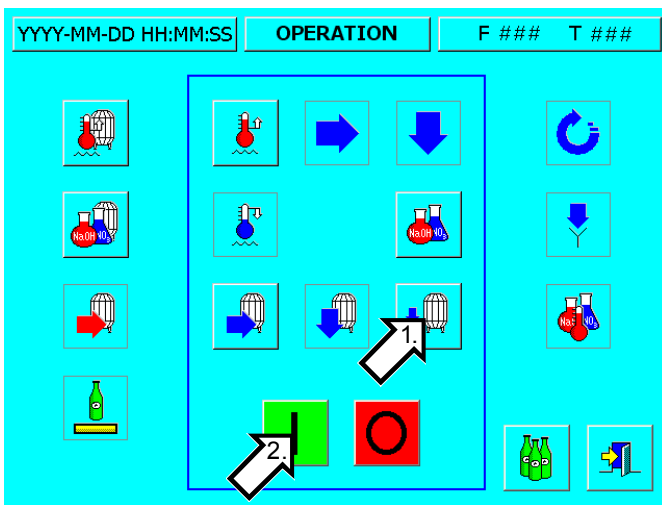

- 3) Stop the draining by pressing the TANK DRAIN button followed by the STOP button.

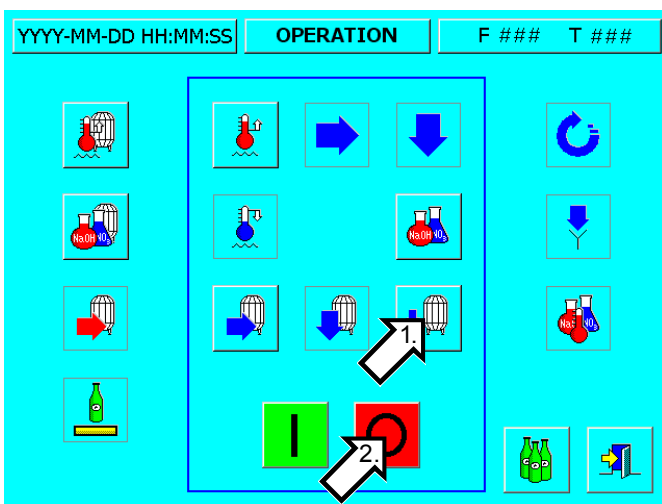

Cleaning



WARNING!

Chemical hazard

Cleaning solutions contain caustic soda (NaOH) or nitric acid (HNO₃). These chemicals may cause severe burnings. Use protective clothing as outlined in the **SAFETY INSTRUCTIONS**.

Caution!

Do not proceed if personnel are present in the risk area

Before starting check that:

- The FLEXITHERM™ is in OFF
- The shut-off valve on the cooling medium outlet side on the heat exchanger is open (to allow for heat expansion)
- Upstream/downstream equipment are connected for CIP

If the OPERATION picture isn't displayed:

- 1) Press the OPERATION button on the MAIN picture.

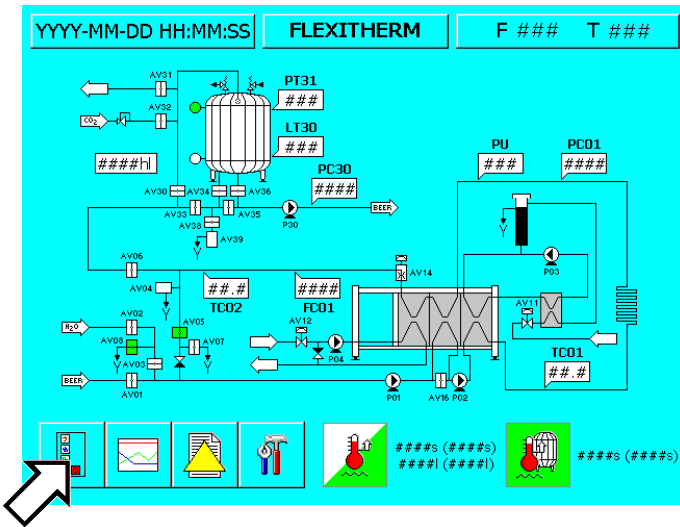

- 2) If the tank is to be cleaned together with the pasteurizer, select tank CIP by pressing the TANK CIP button.

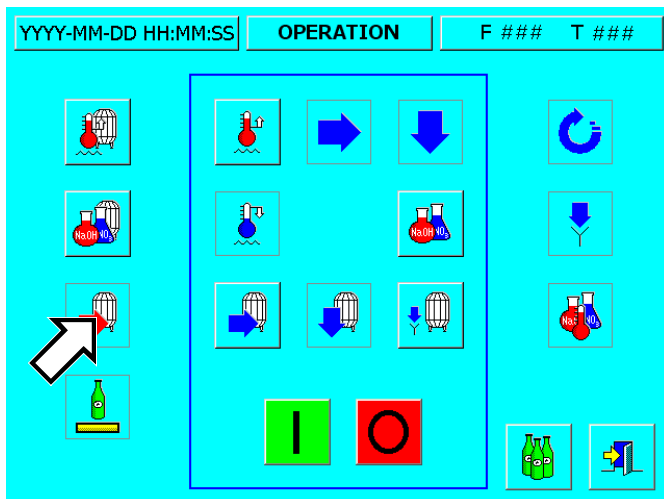

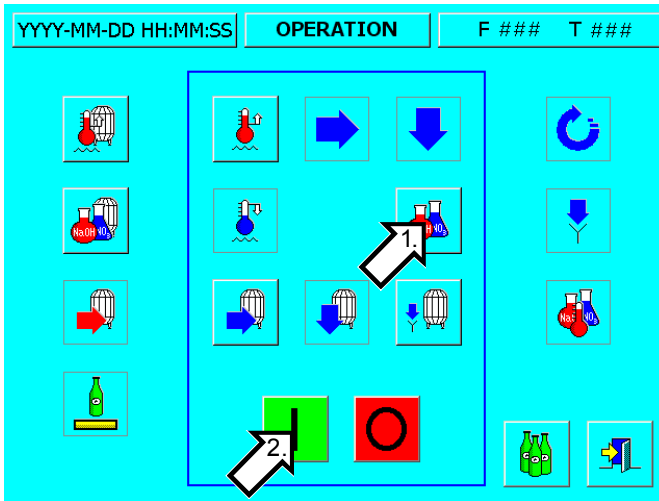

- 3) Start the cleaning by pressing the CIP button followed by the START button.
- 4) The CIP operation is controlled from the external CIP STATION.

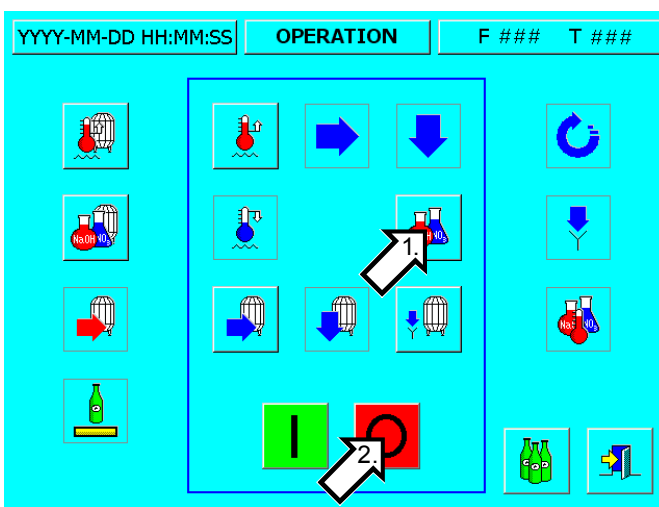

- 5) The FLEXITHERM™ goes to OFF when the external CIP system has finished, or after first pressing the button CIP and then the button STOP.
- 6) Close all manual shut-off valves.

Settings

Set points, volumes, timers etc. are stored in registers in the control system. Before changing these settings an access password/user name has to be entered. For a complete listing of the registers, see **Parameter list**.

Caution!

A change of setting(s) change(s) the way the FLEXITHERM™ works. (If no new value is entered, the old value remains unchanged).

Inspection/change of register value(s)

If the SERVICE picture isn't displayed:

- 1) Press the SERVICE button on the MAIN picture.

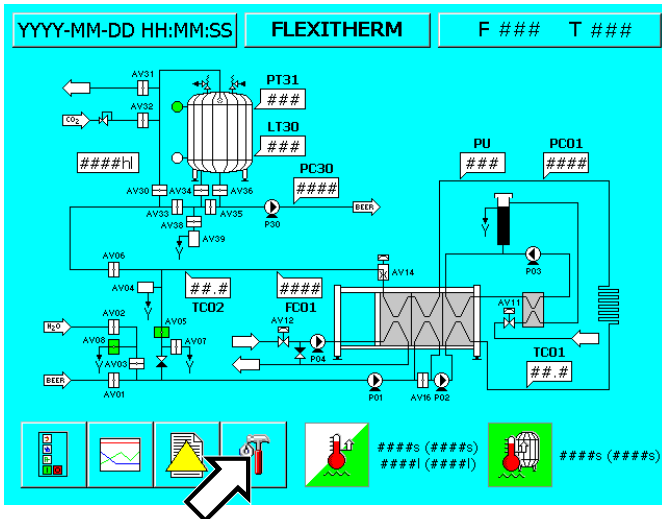

- 2) Press the REGISTER button.
- 3) If no valid password/user name has been entered, key in the password/user name followed by ENTER.
- 4) Key in the register number to be inspected/changed. The number can be between 100 and 299. After entering the number press ENTER.

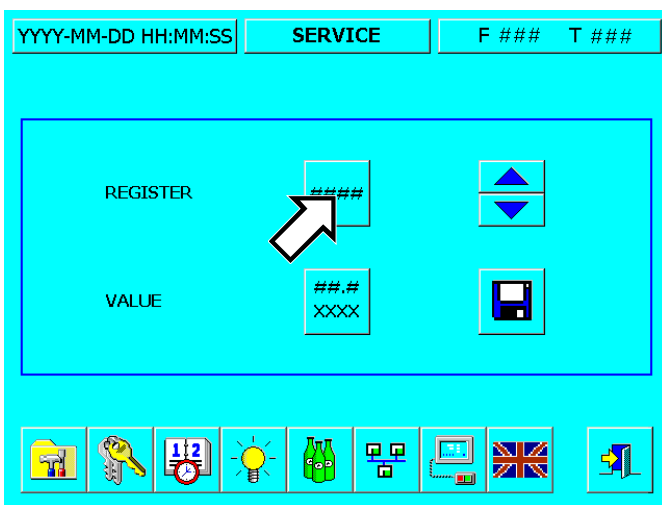

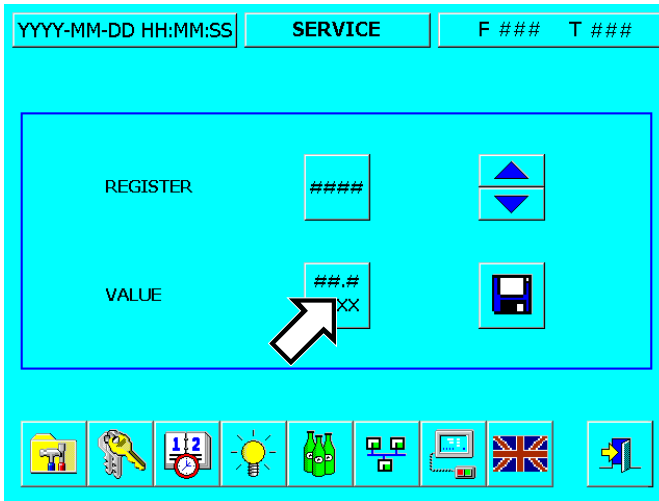

5) If the register is to be changed, press the VALUE button, enter the desired value and then press ENTER.

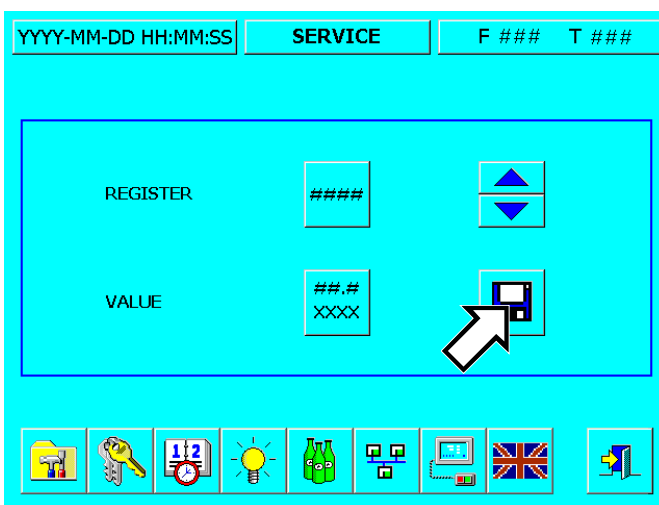

6) To save the new value press the SAVE button.



- 4) When a beer type is selected, set points as below are loaded to the controllers.
 - Pasteurizing units
 - Pasteurizing temperature
 - Cooling temperature
 - Fixed flow rate
 - Holding cell pressure
 - Tank pressure
 - Tank outlet pressure
- 5) These set points can be changed temporarily, by pressing the desired setpoint button.
- 6) If no valid password/user name has been entered, key in the correct password/user name followed by ENTER.
- 7) Enter a new value followed by ENTER. For permanent changes of the beer type set points, see **Changing beer type set points**.

Selection of PU/Fixed temperature

If the TC01 CONTROLLER picture isn't displayed:

- 1) Press the TC01 controller on the MAIN picture.

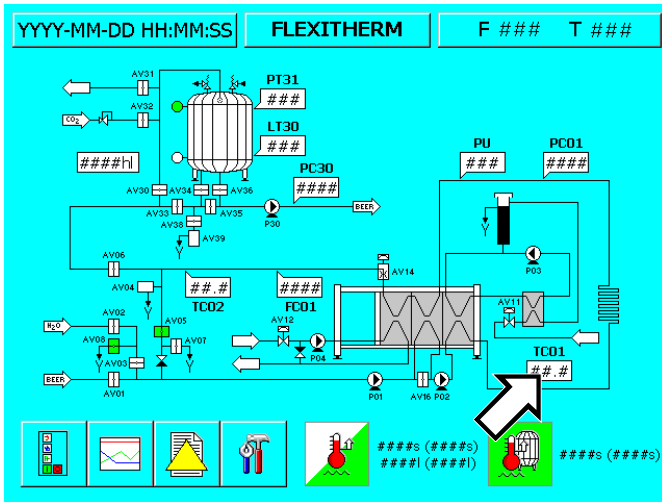

- 2) Select mode by pressing the desired symbol. The modes work as follows.

- A. PU, the system adjusts the pasteurizing temperature in order to maintain a constant PU.
- B. TEMP, the pasteurizing temperature setpoint remains constant. This can only be selected during FIXED flow.

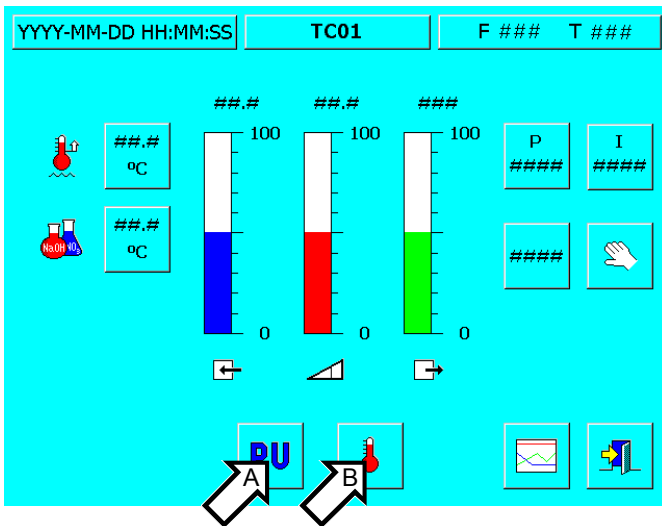

Selection of Auto/Min/Fixed flow (only if -VB/VM)

If the FC01 CONTROLLER picture isn't displayed:

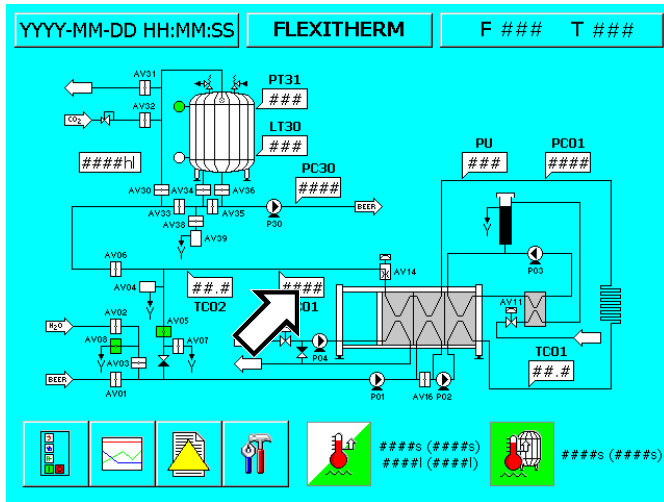

- 1) Press the FC01 controller on the MAIN picture.

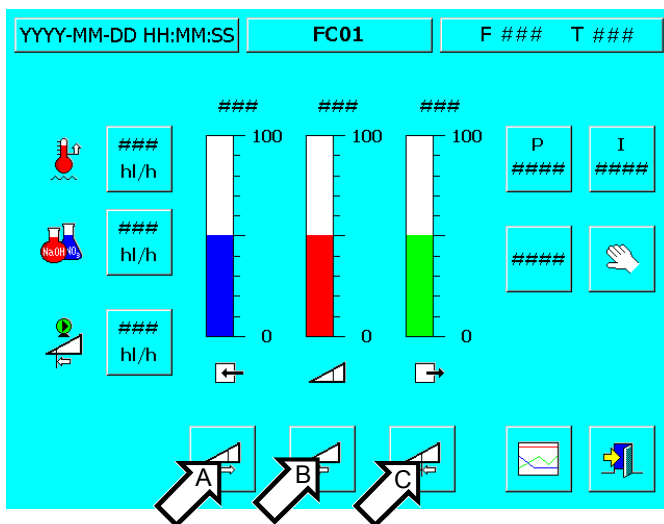

- 2) Select mode by pressing the desired symbol. The different modes work as follows.

- A. AUTO flow rate, operates when the PU mode is selected. The flow rate is varied according to the level in the PBT and the pasteurizing temperature is adjusted accordingly to maintain a constant PU.
- B. MIN flow rate, operates when the PU mode is selected. The flow rate is kept as low as possible and the pasteurizing temperature is adjusted accordingly to maintain a constant PU.
- C. FIXED flow rate, operates when either PU or TEMP mode is selected. The flow is kept at the selected fixed flow rate. As the flow is constant the temperature is constant.

Changing beer type set points

If the BEER TYPE SERVICE picture isn't displayed:

- 1) Press the SERVICE button on the MAIN picture.

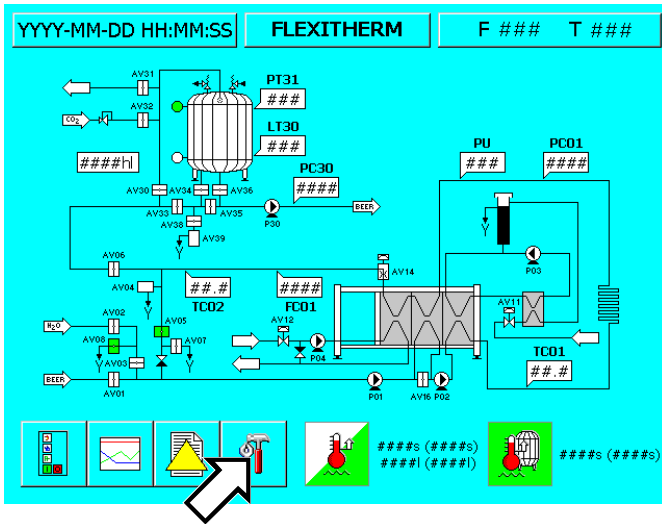

- 2) Press the BEER TYPE button.

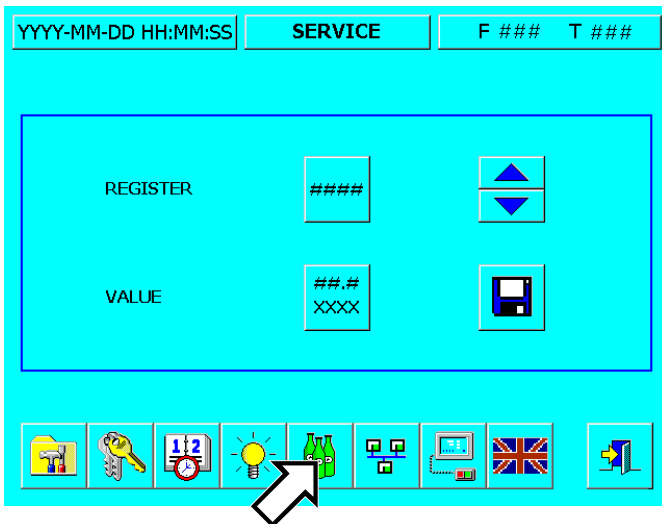

- 3) On the BEER TYPE SERVICE picture, select the desired beer type by pressing the up or down arrow.

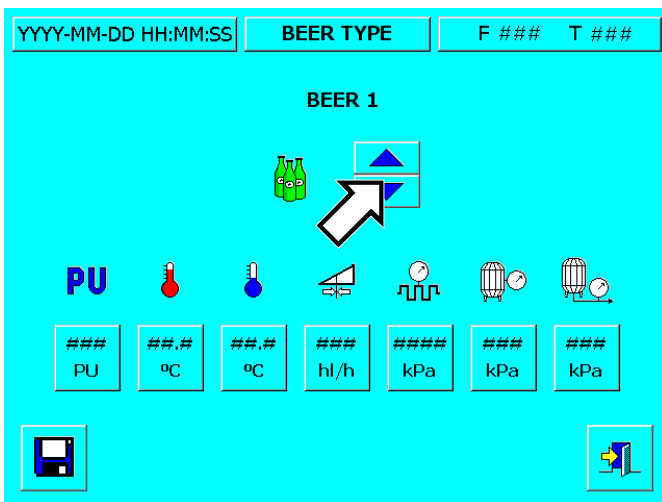



- 4) Press the setpoint to be changed.
- 5) If no valid password/user name has been entered, key in the correct password/user name followed by ENTER.
- 6) Enter the new value followed by ENTER.

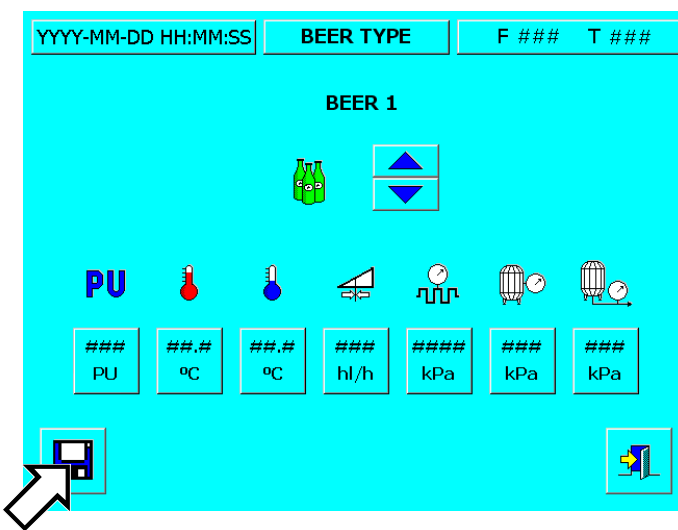

- 7) To save the new value press the SAVE button.

