



CDA USA, Inc
7500 Ranco Road
Henrico, VA 23228
Phone # 804-918-3707

LABELING & FILLING SYSTEMS

CDA USA is a manufacturer of filling, capping, and labeling machines based in Richmond, VA.

CDA as a group :



CDA's Growth Since 1991...

- 10,000 machines manufactured every year
- 130 employees
- 105 countries utilizing our equipment
- Manufacturing plant in RVA.
- 1 billion products packed/year

At **CDA**, we specialize in manufacturing filling, capping, and labeling machines for bottles of all shapes and liquid viscosities. Our machines are designed for simplicity and seamless application, ensuring effortless operation. We pride ourselves on providing exceptional customer service, making CDA more than a supplier—we're your dedicated partner in success.

THE E-FILL

Filling, capping and labelling

PRODUCTION RATE: up to 25 products/minute (depending on label, container size and product viscosity)



[Click here to access the product file on our website !](#)

TECHNICAL DESCRIPTION :

- Welded plate frame in 304 stainless steels on feet.
- 304 stainless steel conveyors with ACETAL slate band chain.
- Asynchronous motors on inverters.
- Watertight electrical box in 304 stainless steels.
- Intuitive color touchscreen with labelling memorization (up to 50) and self-diagnostic.
- Selection star wheel allowing successively the filling and capping.
- Automatic screw capping station.
- 1 label dispenser for cylindrical products (2nd label dispenser in option).
- A recollection rotating table Ø700mm.

PRODUCT FEEDING OPTIONS

Plastic bottles unscrambler:



CDA manufactures plastic bottles unscrambler. This unscrambler specially designed for plastic bottle is outfitted with :

- 3000-5000 cap elevator
- Automatic unscrambler to sort cap out
- High- and low-level alarm (light)
- HMI Control touch screen



Feeding table:

CDA manufactures feeding tables for plastic, glass and metal containers.

- 27- and 40-inches diameter available
- Loading shelves available in option
- Feeding table includes emergency stop knob, and frequency potentiometer

FILLING BY:

PERISTALTIC PUMP

Controlled by the E-FILL touchscreen



TECHNICAL DESCRIPTION:

- Peristaltic dispenser for liquids from 1 mL to 1L, with an accuracy of +/- 0.5%
- Control through keyboard and LCD touchscreen
- Pump head in anodized aluminum outfitted with 12 stainless steel rollers built on ball bearing.
- Correction, re-aspiration, speed and acceleration control

OR

DOSING SYSTEM BY PISTON



TECHNICAL DESCRIPTION:

- Piston size available from 1mL to 40mL all the way up to 50mL to 1200mL
- Built on a CDA stainless steel trolley with wheels.
- Outfitted with a 30L hopper.

OR

POSITIVE DISPLACEMENT PUMP AND FLOWMETER



TECHNICAL DESCRIPTION:

- Self-priming centrifugal or impeller pump
- Pump body, turbine and shaft in 316L stainless steel
- Electromagnetic flow meter or mass flow meter (for conductive and nonconductive liquids)
- Adjustable flow from 400 to 1000 l/h
- Selector to reverse flow
- DN25 clamp connector at the inlet (another connector available on request).
- Anti drip nozzle with shut off valve
- Minimum dose = 1.5oz

STARWHEEL AND CAP APPLICATION

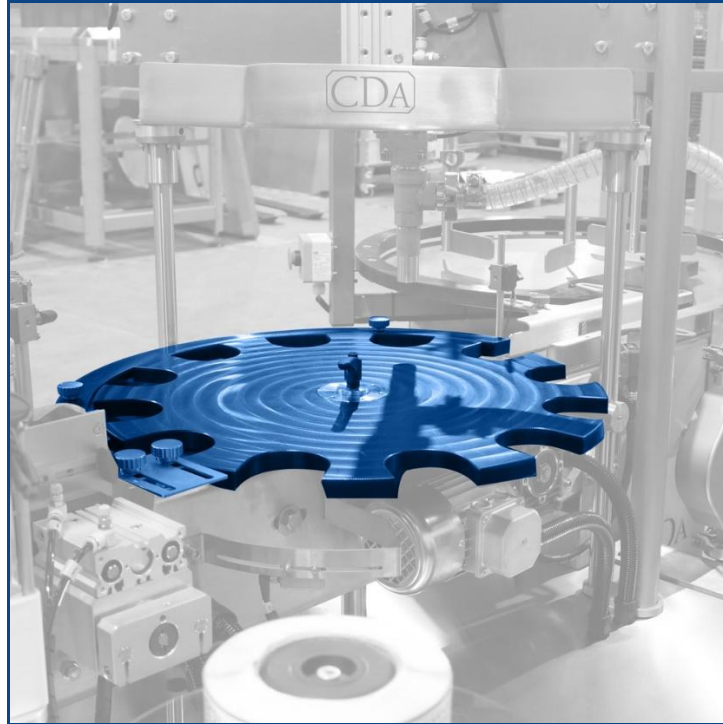

Rotating star adapted to the product which allows stabilizing of the product while filling and placing of the cap.

NB: Cap dispensing and pre tightening will be made manually.

TECHNICAL DESCRIPTION:

- Stainless steel conveyor 82.5 mm wide with ACETAL slate band chain (+/-700mm of accumulation length)
- Adapted system for products diameters from 18 mm to 90mm.
- Rotating star designed and made for each format of bottles.
- 370W asynchronous motorization on speed inverter
- Automatic control sensors to check if the tip and/or cap are on the bottle.
- 2 stainless steel bowls to make the tips and caps easily accessible.

SCREW CAPPING STATION VS400



TECHNICAL DESCRIPTION:

- Products lock system by pneumatic cylinder for cylindrical products anti-rotation.
- Capping with double guiding system with motorized adjustable height through the touchscreen
- Low tension electric capper (320 tours / min) with adjustable capping head without tools (0.7 à 3Nm).
- Screw capping device built on pneumatic cylinder
- Capping head made regarding to your cap (diameter, height...).

Other capping options includes: VS500 (belt capper for pumps), Tip or cap pusher, vials crimpers...

LABELING STATION

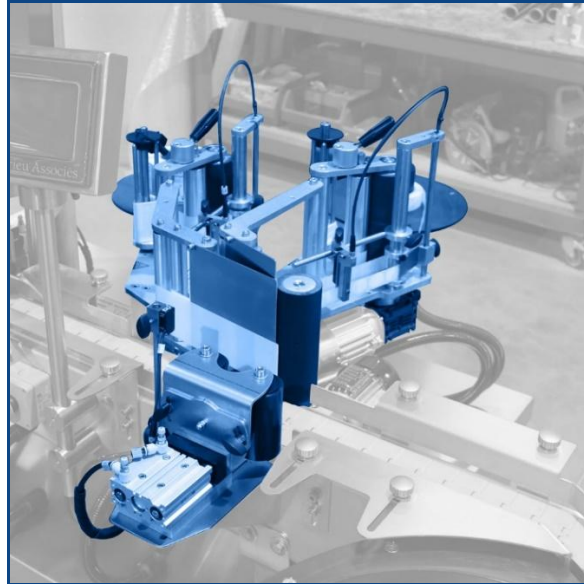

(In blue on the above picture)

THE 3 POINTS TECHNOLOGY

The “3 points” technology allows the bottles to be hold in between 3 rollers while spinning, which gives a better labeling and smoothing quality of the label on the bottle; with this technology we avoid any risk of bubbles or wrinkles on the applied label.

TECHNICAL DESCRIPTION:

- Label dispensers built on a motorized height regulation system driven through the digital display.
- Product(s) pusher adapted to the material, shape and rigidity to the product(s) we have to label.
- Smoothing roller 61 mm diameter adapted to the product(s).
- Up to 50 memories from the digital display.
- Clear labels gap sensor (Option).
- Heights setting memories. (Option).

WINDING DIRECTION: LEFT OUT

Dimensions of the label rolls:

- A: inside diameter = 75mm
- B: Max. Outside diameter = 260mm
- C: Max. Band height = 160mm (Higher on demand)
- D: Space between labels = 3-5mm

Note: The rolls have to be stored in a dry place between 15°C and 18°C

Machine delivered with EC Standards

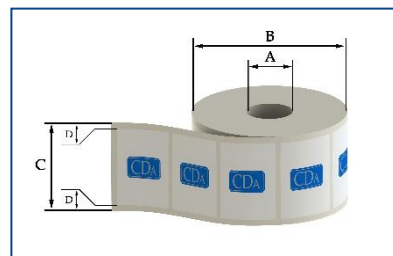

ROTATING RECOLLECTION TABLE



TECHNICAL DESCRIPTION :

- Rotating table Ø700 mm.
- Outside railing in PEHD.

TECHNICAL FEATURES

Approximative weight	800 lbs
Power consumption	1,5 kW
Power supply	220V SINGLE PHASE
Frequency	~ 50 Hz 16 A
Production rate	Up to 25 products/mn
Control	touchscreen
Chain Height	+/- 925 mm
Air consumption	4 m ³ / hour max. under 4 bars – dry and no lubricated air (depending on options)
Ideal running temperature	from 10°C to 30°C
Working direction	From left to right



PRICING

Brands International	25022701GG
E FILL	QTY
Machine Includes:	
• Frame in stainless steel 304	
• Two motorized conveyor	
• One star wheel indexed with laser sensor	
• Electrical cabinet	
• HMI touchscreen	
• Inlet jam sensor	
Feeding table 27.5 inches	1
Loading tablet for pharma finish	1
Conveyor height (If not standard (=36.4 inches height)	INCLUDED
Stainless steel conveyor - Chain width 3.25 inches	INCLUDED
Peristaltic pump (includes 3 tubing boxes of 30ft + 1 box with 10 Y connectors)	2
Dosing needle stainless steel 316L	2
VS400 CAPPING STATION	1
One label dispenser for front labels (maxi label height 160 mm = 6.30 inches) built on a motorized height regulation system driven through the digital display	1
Clutch support plate	1
Independent rotating accumulation table 27.5 inches	1
U conveyor 3.25 inches width (15ft of straight conveyor + 6ft of curved conveyor)	1
Transfer belts	1
Protective encasing for capper with emergency shut off door	1
TOTAL MACHINE	\$ 138,129.00
PACKAGING (crate + labor)	\$ 1,575.00
SHIPPING (Newmarket, ON L3X 2S2 (excl. Custom duties))	\$ 3,800.00
TOTAL FOB Richmond, VA	\$ 143,504.00

By signing this Sales Order Acknowledgement in the following box, I accept the above pricing and CDA USA Inc. Terms and Conditions of Sale:

Signature _____

Date _____



CDA USA, Inc
7500 Ranco Road
Henrico, VA 23228
Phone # 804-918-3707

Options	Price
Additional star wheel (E-Fill)	\$ 1,679.00
Additional capping head	\$ 825.00
Ultrasonic fork sensor for clear label	\$ 1,230.00
End of the line extended version incl rectangular accumulation table	\$ 10,093.00
Heat shrinking tunnel	\$ 4,442.00
Deitz neck ban dispenser	\$ 27,739.00
Axon sleeves dispenser EZ 100	\$ 53,828.00
Axon sleeves heat tunnel Thermoray deluxe	\$ 13,871.00
Axon sleeves steam Thermoflow	\$ 40,425.00
Extended warranty 1 year on parts	\$ 6,649.00

CDA USA Inc. Terms and Conditions of Sale



CDA USA, Inc
7500 Ranco Road
Henrico, VA 23228
Phone # 804-918-3707

LABELING & FILLING SYSTEMS

Page | 13



CDA USA, Inc
7500 Ranco Road
Henrico, VA 23228
Phone # 804-918-3707

LABELING & FILLING SYSTEMS



CDA USA, Inc
7500 Ranco Road
Henrico, VA 23228
Phone # 804-918-3707

LABELING & FILLING SYSTEMS



CDA USA, Inc
7500 Ranco Road
Henrico, VA 23228
Phone # 804-918-3707

LABELING & FILLING SYSTEMS