



Service Manual

**Force FX™**

**Electrosurgical Generator C**



Service Manual

**Force FX™**

**Electrosurgical Generator C**

## Preface

This manual and the equipment it describes are for use only by qualified medical professionals trained in the particular technique and surgical procedure to be performed. It is intended as a guide for servicing the Force FX Electrosurgical Generator C only. Additional users information is available in the *Force FX Electrosurgical Generator C User's Guide*.

### Equipment covered in this manual:

Covidien Force FX Electrosurgical Generator C  
110 V ~ Nominal / 230 V ~ Nominal (auto selected)

The *Force FX Electrosurgical Generator C Service Manual* consists of two parts: the text (part 1 of 2) and a *Schematics Supplement* (part 2 of 2) which contains the schematics.

Device is compliant with the European Communities Council Directive 93/42/EEC, Medical Device Directive.

## Conventions Used in this Guide

### Warning

Indicates a potentially hazardous situation which, if not avoided, could result in death or serious injury.

### Precaution

Indicates a hazardous situation which, if not avoided, may result in minor or moderate injury.

### Notice

Indicates a hazard which may result in product damage.

### Important

Indicates an operating tip or maintenance suggestion.

## Limited Warranty

Covidien warrants the covered product listed below to be free from defects in material and workmanship for normal use and service for the period(s) set forth below. Covidien's obligation under this warranty is limited to the repair or replacement, at its sole option, of any product, or part thereof, which has been returned to it (or its authorized distributor) within the applicable time period shown below after delivery of the product to the original purchaser, and which examination discloses, to Covidien's satisfaction, that the product is defective. This limited warranty does not apply to any product, or part thereof, which has been repaired or altered in a way so as, in Covidien's judgment, to affect its stability or reliability, or which has been subjected to misuse, neglect, or accident.

The warranty period for this Covidien product is as follows:

<b>Electrosurgical Generators</b>	One year from date of shipment
<b>Mounting Fixtures (all models)</b>	One year from date of shipment
<b>Footswitches (all models)</b>	One year from date of shipment
<b>Sterile Single Use Items</b>	Sterility only as stated on packaging
<b>Patent Return Electrodes</b>	Shelf life only as stated on packaging

Notwithstanding any other provision herein or in any other document or communication, Covidien's liability with respect to this limited warranty and the products sold hereunder shall be limited to the aggregate purchase price for the products sold to the customer. This limited warranty is non-transferable and runs only to the original purchaser of the covered product(s). There are no warranties which extend beyond the terms hereof. Covidien disclaims any liability hereunder or elsewhere in connection with the sale of products and for any form of indirect, tort, or consequential damages.

This limited warranty and the rights and obligations hereunder shall be construed under and governed by the laws of the State of Colorado, USA. The sole forum for resolving disputes arising under or relating in any way to this limited warranty is the District Court of the County of Boulder, State of Colorado, USA.

Covidien reserves the right to make changes in covered products built or sold by it at any time without incurring any obligation to make the same or similar changes to equipment previously built or sold by it.

**THE OBLIGATION TO REPAIR OR REPLACE A DEFECTIVE OR NONPERFORMING PRODUCT IS THE SOLE REMEDY OF THE CUSTOMER UNDER THIS LIMITED WARRANTY. EXCEPT AS EXPRESSLY PROVIDED HEREIN, COVIDIEN DISCLAIMS ALL OTHER WARRANTIES, WHETHER EXPRESS OR IMPLIED, ORAL OR WRITTEN, WITH RESPECT TO PRODUCTS, INCLUDING WITHOUT LIMITATION ALL IMPLIED WARRANTIES, WARRANTIES OF MERCHANTABILITY OR FITNESS FOR A PARTICULAR PURPOSE.**

## Software License

Covidien llc, (collectively called "COVIDIEN" herein) own the entire right, title, and interest in and to all of the computer programs and all portions thereof, and associated documentation (collectively, the "Software") provided to Customer as may be installed in the Products and equipment addressed herein or provided separately, and it has the sole right to grant licenses hereunder.

The evaluation allowance herein and any ultimate price paid by Customer for the products incorporating the Software include as a portion of that evaluation allowance, or price, a license fee granting Customer only the rights set forth in this Software License. Customer further acknowledges and agrees that the Software is owned exclusively by COVIDIEN. The Software is licensed to be used on only one computing device or Product, and a valid license must be purchased for each computing device on which the Software is installed.

**Single User License Grant:** COVIDIEN grants to Customer a limited, nonexclusive, non-sublicensable, nontransferable and revocable license to use the Software, exclusively at Customer's location as identified by Customer as the ship-to location of the Product, solely in machine-readable object code form only on a single central processing unit owned or leased by Customer or otherwise embedded in equipment provided by COVIDIEN, and for the sole purpose of Customer's internal business purpose in the operation of the Product or equipment purchased from, other otherwise provided by, COVIDIEN or its affiliates.

Except to the extent expressly authorized in this Software License or by law, Customer shall not and shall not cause any third party to: (i) decompile, disassemble, or reverse engineer the Software; (ii) modify or create any derivative works (including, without limitation, translations, transformations, adaptations or other recast or altered versions) based on the Software, or alter the Software in any way; (iii) merge the Software with any other software or product not supplied by Supplier; (iv) use, copy, sell, sublicense, lease, rent, loan, assign, convey or otherwise transfer the Software except as expressly authorized by the Agreement; (v) distribute, disclose or allow use of the Software, in any format, through any timesharing service, service bureau, network or by any other means, to or by any third parties; (vi) remove or modify any copyright, confidential and/or proprietary markings, legends or restriction which are in the Software originally supplied to Customer; or (vii) violate any obligations with regard to COVIDIEN's Confidential Information. To the extent that Customer is expressly permitted by applicable mandatory law to undertake any of the activities listed in the preceding sentence, Customer will not exercise those rights until Customer has given COVIDIEN thirty (30) days written notice of Customer's intent to exercise any such rights unless an order of a government agency of competent jurisdiction will not so allow.

Except for the limited license rights expressly granted in this Software License, COVIDIEN reserves all rights in and to the Software and any modifications thereto and derivations thereof, including, but not limited to, all title, ownership, intellectual property rights and all other rights and interests. Customer will own only the hardware or physical media on which the Software is stored or processed, if any.

Customer agrees that the Software, including the specific design and structure of individual programs, constitute confidential information and trade secrets of COVIDIEN, whether or not the programs may be copyrighted or copyrightable, and/or patented or

patentable. Customer agrees not to disclose, provide, or otherwise make available such confidential information, trade secrets or copyrighted material in any form to any third party. Customer agrees that it will make the Software available only to employees, contractors, or consultants with a need to know, who are obligated to comply with all license restrictions contained in this Software License Agreement and to maintain the secrecy of the Software and all other Confidential Information. Customer is responsible for the compliance of all users with these obligations.

Customer may, from time to time, request that COVIDIEN incorporate certain features, enhancements or modifications into the Software. COVIDIEN may, in its sole discretion, undertake to incorporate such changes and distribute the Software so modified to all or any of COVIDIEN's customers. All such error corrections, bug fixes, patches, updates or other modifications provided to COVIDIEN shall be the sole property of COVIDIEN.

This Software License is effective until terminated. Customer may terminate this License at any time by destroying all copies of Software including any documentation. This License will terminate immediately upon notice from COVIDIEN if Customer fails to comply with any provision of this License or any supplier agreement. COVIDIEN may terminate the Software licenses granted herein and exercise all available rights by giving written notice, effective immediately, if within ten (10) business days of Customer's receipt of a reasonably detailed written request to cure, Customer has not cured all breaches of this License's limitations or restrictions. Upon such termination, Customer will immediately pay all undisputed fees outstanding, cease use of all Software, return or delete, at COVIDIEN's request, all copies of the Software in Customer's possession, and certify compliance with all of the obligations herein to COVIDIEN in writing.

**Limited Warranty:** COVIDIEN represents and warrants to Customer that the Software will perform substantially as described in COVIDIEN's then current documentation for such Software for the longer of (a) the remaining warranty applicable to the product with which such Software was delivered (not to exceed one year) or (b) ninety (90) days from the date such Software was shipped or first made available to Customer for electronic download from COVIDIEN's service site. If you notify COVIDIEN of defects during the warranty period, COVIDIEN will replace the Software or, at its option, refund the purchase price. Your remedy for breach of this limited warranty shall be limited to replacement or refund and shall not encompass any other damages. No dealer, distributor, agent or employee of COVIDIEN is authorized to make any modification or addition to the warranty and remedies stated above.

Notwithstanding these warranty provisions, all of COVIDIEN's obligations with respect to such warranties shall be contingent on Customer's use of the Software in accordance with this Agreement and in accordance with COVIDIEN's instructions as provided by COVIDIEN in the documentation, as such instructions may be amended, supplemented, or modified by COVIDIEN from time to time. COVIDIEN shall have no warranty obligations with respect to any failures of the Software which are the result of accident, abuse, misapplication, extreme power surge or extreme electromagnetic field.

This warranty does not apply to any damages, malfunctions, or non-conformities caused to or by: (i) Customer's use of Software in violation of the license granted under the Agreement or in a manner inconsistent with any provided documentation; (ii) use of non-COVIDIEN furnished equipment, software, or facilities with its equipment or Products; (iii) Customer's failure to follow COVIDIEN's installation, operation, repair or maintenance instructions; (iv) Customer's failure to permit COVIDIEN timely access, remote or

otherwise, to Products; (v) failure to implement all new Updates to Software provided under the Agreement; (vi) Products or equipment with their original manufacturer's serial numbers altered, defaced or deleted; (vii) Products or equipment that have been altered, serviced or modified by a party other than COVIDIEN; or (viii) Software that has been subjected to abnormal physical or electrical stress, misuse, negligence or accident by Customer or a third party.

DISCLAIMER: EXCEPT AS SPECIFIED IN THIS WARRANTY, ALL EXPRESS OR IMPLIED CONDITIONS, REPRESENTATIONS, AND WARRANTIES INCLUDING, WITHOUT LIMITATION, ANY IMPLIED WARRANTY OF MERCHANTABILITY, FITNESS FOR A PARTICULAR PURPOSE, OR ARISING FROM A COURSE OF DEALING, USAGE, OR TRADE PRACTICE, ARE HEREBY EXCLUDED TO THE EXTENT ALLOWED BY APPLICABLE LAW.

IN NO EVENT WILL EITHER PARTY BE LIABLE FOR ANY LOST REVENUE, PROFIT, OR DATA, OR FOR SPECIAL, INDIRECT, CONSEQUENTIAL, INCIDENTAL, OR PUNITIVE DAMAGES HOWEVER CAUSED AND REGARDLESS OF THE THEORY OF LIABILITY ARISING OUT OF THIS SOFTWARE LICENSE EVEN IF SUCH PARTY HAS BEEN ADVISED OF THE POSSIBILITY OF SUCH DAMAGES. IN NO EVENT SHALL ONE PARTY'S LIABILITY TO THE OTHER PARTY, WHETHER IN CONTRACT, TORT (INCLUDING NEGLIGENCE), OR OTHERWISE, EXCEED THE PRICE PAID OR TO HAVE BEEN PAID BY CUSTOMER. THE FOREGOING LIMITATIONS SHALL APPLY EVEN IF THE ABOVE-STATED WARRANTY FAILS OF ITS ESSENTIAL PURPOSE. SOME STATES DO NOT ALLOW LIMITATION OR EXCLUSION OF LIABILITY FOR CONSEQUENTIAL OR INCIDENTAL DAMAGES.

**U.S. Government Rights.** The Software is a "commercial item" developed exclusively at private expense, consisting of "commercial computer software" and "commercial computer software documentation" as such terms are defined or used in the applicable U.S. acquisition regulations. The Software is licensed hereunder (i) only as a commercial item and (ii) with only those rights as are granted to all other customers pursuant to the terms and conditions of this License. Customer shall not use, duplicate, or disclose the Software in any way not specifically permitted by this License. Nothing in this License requires COVIDIEN to produce or furnish technical data for or to Customer.

If any provision of this Agreement shall be held by a court of competent jurisdiction to be illegal, invalid or unenforceable, the remaining provisions shall remain in full force and effect.

This License Agreement contains the entire understanding and agreement between the parties respecting the Software. This Agreement may not be supplemented, modified, amended, released or discharged except by an instrument in writing signed by each party's duly authorized representative. All captions and headings in this Agreement are for purposes of convenience only and shall not affect the construction or interpretation of any of its provisions. Any waiver by either party of any default or breach hereunder shall not constitute a waiver of any provision of this Agreement or of any subsequent default or breach of the same or a different kind.

The construction and performance of this Agreement will be governed by the laws of the State of Colorado without reference to its choice of law principles. The parties hereby submit to the jurisdiction of the courts of the State of Colorado.

## Table of Contents

Preface . . . . .	ii
Conventions Used in this Guide . . . . .	ii
Limited Warranty . . . . .	iii
Software License . . . . .	iv

### Chapter 1. Introduction

General Description . . . . .	1-2
List of Components . . . . .	1-2
Service Personnel Safety . . . . .	1-3
General . . . . .	1-3
Active Accessories . . . . .	1-3
Patient Return Electrodes . . . . .	1-4
Fire/Explosion Hazards . . . . .	1-4
Electric Shock Hazards . . . . .	1-4
Servicing . . . . .	1-5
Calibration . . . . .	1-5
Cleaning . . . . .	1-6

### Chapter 2. Controls, Indicators, and Receptacles

Front Panel . . . . .	2-2
Bipolar Controls . . . . .	2-3
Bipolar Instrument Receptacle . . . . .	2-4
Monopolar Cut Controls . . . . .	2-5
Monopolar Coag Controls . . . . .	2-6
Monopolar Instrument Receptacles . . . . .	2-7
REM Alarm Indicator . . . . .	2-8
Rear Panel . . . . .	2-8
Footswitch Receptacles . . . . .	2-9
Monopolar Footswitch Receptacles . . . . .	2-9
Bipolar Footswitch Receptacle . . . . .	2-9
Power Entry Module . . . . .	2-10
Activation Tone Volume Control . . . . .	2-10
Option Panel . . . . .	2-11

### Chapter 3. Technical Specifications

Performance Characteristics . . . . .	3-2
General . . . . .	3-2
Dimensions and Weight . . . . .	3-2
Operating Parameters . . . . .	3-2
Transport and Storage . . . . .	3-3

Duty Cycle . . . . .	3-3
Internal Memory Audio Volume . . . . .	3-4
Storage capacity . . . . .	3-4
Audio Volume . . . . .	3-5
REM Contact Quality Monitor . . . . .	3-5
Serial Port . . . . .	3-6
RF Activation Port . . . . .	3-6
Expansion Port . . . . .	3-7
Low Frequency (50–60 Hz) Leakage Current . . . . .	3-7
High Frequency (RF) Leakage Current . . . . .	3-7
Input Power . . . . .	3-8
Power Cord Specification . . . . .	3-8
Standards and IEC Classifications . . . . .	3-9
Class I Equipment (IEC 60601-1) . . . . .	3-16
Type CF Equipment (IEC 60601-1)/Defibrillator Proof . . . . .	3-16
Liquid Spillage . . . . .	3-16
Electromagnetic Interference . . . . .	3-17
Electromagnetic Compatibility . . . . .	3-17
Cables Used for the Force FX EMC Test . . . . .	3-18
Voltage Transients (Emergency Generator Mains Transfer) . . . . .	3-19
Output Characteristics . . . . .	3-23
Maximum Output for Bipolar and Monopolar Modes . . . . .	3-23
Maximum Output for Ultrasonic Electrosurgery . . . . .	3-24
Available Power Settings in Watts . . . . .	3-24
Output Waveforms . . . . .	3-26
Output Power vs. Resistance Graphs . . . . .	3-27
Bipolar Graphs . . . . .	3-27
Monopolar Cut Graphs . . . . .	3-34
Monopolar Coag Graphs . . . . .	3-42

**Chapter 4. Principles of Operation**

Block Diagram . . . . .	4-2
Functional Overview . . . . .	4-3
Instant Response Technology . . . . .	4-3
Ultrasonic Electrosurgery . . . . .	4-3
Simultaneous Coag . . . . .	4-3
REM Contact Quality Monitoring System . . . . .	4-4
Control Board . . . . .	4-6
Microcontrollers . . . . .	4-6

Main Microcontroller . . . . .	4-6
Feedback Microcontroller . . . . .	4-7
Shared RAM . . . . .	4-8
I/O Expansion . . . . .	4-8
Keyboard Interface and Activation Inputs. . . . .	4-8
Power Supply Supervisor Circuit. . . . .	4-9
A/D and D/A Conversion . . . . .	4-9
Waveform Generation (T_ON ASIC). . . . .	4-9
T_ON Average Check. . . . .	4-10
Audio Alarm. . . . .	4-10
Serial Interface. . . . .	4-10
Dosage Error Algorithm . . . . .	4-11
Instant Response Algorithm . . . . .	4-12
Front Panel . . . . .	4-13
Membrane Keyboard . . . . .	4-13
Power Switch . . . . .	4-13
REM Connector/Switch . . . . .	4-13
CEM Mechanism Switch . . . . .	4-13
Display Board . . . . .	4-14
RF Indicator Lamps . . . . .	4-14
REM Indicators. . . . .	4-14
LED and Seven-Segment Display Drivers . . . . .	4-14
CEM Switch Circuit. . . . .	4-15
Mode Selection and Power Control Switches . . . . .	4-15
Footswitch Board . . . . .	4-16
Footswitch Decode Circuit . . . . .	4-16
Audio Circuit . . . . .	4-17
Power Supply/RF Board . . . . .	4-18
Power Supply/RF Board Interfaces . . . . .	4-19
High Voltage Power Supply . . . . .	4-19
Low Voltage Power Supply. . . . .	4-22
RF Output Stage . . . . .	4-22
Spark Control Circuit. . . . .	4-25
RF Leakage Reduction Circuit. . . . .	4-26
REM Circuit. . . . .	4-26
IsoBloc Circuit. . . . .	4-27
Temperature Sense Circuits. . . . .	4-28

## **Chapter 5. Setup, Tests, and Adjustment**

Setting Up the Generator . . . . .	5-2
------------------------------------	-----

Connections for Bipolar or Macrobipolar Surgery . . . . .	5-4
Setting the Bipolar Output . . . . .	5-5
Connections for Monopolar Surgery . . . . .	5-6
Selecting Cut and Coag Modes . . . . .	5-8
Simultaneous Coag . . . . .	5-8
Using Two Generators Simultaneously . . . . .	5-10
Connecting the CUSA Handpiece with CEM Nosecone . . . . .	5-11
Setting the Output Power . . . . .	5-12
Simultaneous Coag with a CUSA System . . . . .	5-12
Changing the Mode . . . . .	5-12
Changing the Power Setting . . . . .	5-13
Activating the Surgical Instrument . . . . .	5-13
Periodic Safety Check . . . . .	5-14
Recommended Test Equipment . . . . .	5-15
Inspecting the Generator and Accessories . . . . .	5-16
Inspecting the Internal Components . . . . .	5-17
Testing the Generator . . . . .	5-18
Verifying REM Function . . . . .	5-19
Confirming Outputs . . . . .	5-19
Checking the Bipolar Output . . . . .	5-19
Checking Output for the Monopolar Cut Modes . . . . .	5-20
Checking Output for the Monopolar Coag Modes . . . . .	5-22
Checking Low Frequency Leakage Current and Ground Resistance . . . . .	5-23
Checking High Frequency Leakage Current . . . . .	5-24
Calibrating the Generator . . . . .	5-26
Preparing for Calibration . . . . .	5-27
Entering Calibration Mode . . . . .	5-27
Exiting Calibration Mode . . . . .	5-28
Verifying the Generator Data . . . . .	5-28
Adjusting the Calendar . . . . .	5-29
Adjusting the Clock . . . . .	5-30
Checking and Adjusting the REM Oscillator Frequency and Impedance . . . . .	5-30
Checking and Adjusting the Current Sense Gain . . . . .	5-31
Checking and Adjusting the Voltage Sense Gain . . . . .	5-33
Checking and Adjusting the Reactance Gain . . . . .	5-36
Checking and Adjusting the ECON Factor . . . . .	5-38
Using the RS-232 Serial Port . . . . .	5-42
Establish the Communications Link . . . . .	5-42

Enter the Commands. . . . .	5-43
Disconnect the Computer from the Generator . . . . .	5-46

**Chapter 6. Troubleshooting**

Inspecting the Generator. . . . .	6-2
Inspecting the Receptacles . . . . .	6-2
Inspecting the Internal Components . . . . .	6-3
Correcting Malfunctions . . . . .	6-4
Responding to System Alarms. . . . .	6-11
Correcting T_ON ASIC Malfunctions. . . . .	6-22
Correcting Battery-Backed RAM Malfunctions . . . . .	6-24

**Chapter 7. Replacement Procedures**

Interconnect Diagram . . . . .	7-2
Battery Replacement . . . . .	7-3
Control Board Replacement . . . . .	7-4
Display Board Replacement. . . . .	7-5
Remove the Display Board . . . . .	7-5
Install the Display Board . . . . .	7-6
Display Board Seven-Segment LED Replacement. . . . .	7-7
Fan Replacement . . . . .	7-7
Footswitch Board Replacement. . . . .	7-8
Front Panel Replacement. . . . .	7-9
Remove the Front Panel Assembly . . . . .	7-9
Remove and Reinstall the Front Panel Components. . . . .	7-9
Install the Front Panel Assembly. . . . .	7-10
Front Panel REM Module Replacement . . . . .	7-11
Front Panel Power Switch Replacement. . . . .	7-12
Fuse Replacement . . . . .	7-13
Replacing Fuses in the Fuse Drawer . . . . .	7-13
Replacing the Fuse on the Power Supply/RF Board. . . . .	7-14
Left Front Heat Sink and Component Replacement . . . . .	7-15
Remove the Left Front Heat Sink . . . . .	7-15
Replace Left Front Heat Sink Components . . . . .	7-16
Install the Left Front Heat Sink. . . . .	7-16
Left Rear Heat Sink and Component Replacement . . . . .	7-17
Remove the Left Rear Heat Sink. . . . .	7-17
Replace Left Rear Heat Sink Components . . . . .	7-18
Install the Left Rear Heat Sink . . . . .	7-18
Right Heat Sink and Component Replacement . . . . .	7-19
Remove the Right Heat Sink . . . . .	7-19

Replace Right Heat Sink Components . . . . .	7-20
Install the Right Heat Sink . . . . .	7-21
Low Voltage Power Supply Replacement . . . . .	7-22
Remove the Low Voltage Power Supply . . . . .	7-22
Install the Low Voltage Power Supply . . . . .	7-22
Power Entry Module Replacement . . . . .	7-24
Remove the Power Entry Module . . . . .	7-24
Install the Power Entry Module . . . . .	7-25
Power Supply/RF Board Replacement . . . . .	7-26
Remove the Power Supply/RF Board Assembly . . . . .	7-26
Remove Components from the Old Board . . . . .	7-27
Install Components on the New Board . . . . .	7-28
Install the Power Supply/RF Board Assembly . . . . .	7-29

**Chapter 8. Repair Policy and Procedures**

Responsibility of the Manufacturer . . . . .	8-2
Returning the Generator for Service . . . . .	8-2
Obtain a Return Authorization Number . . . . .	8-2
Clean the Generator . . . . .	8-3
Ship the Generator . . . . .	8-3
Returning Circuit Boards . . . . .	8-3
Service Centers . . . . .	8-3
Training/Education . . . . .	8-4

**Chapter 9. Service Parts**

Ordering Replacement Parts . . . . .	9-2
Generator Assembly . . . . .	9-3
Parts List . . . . .	9-5
Front Panel Assembly . . . . .	9-7
Parts List . . . . .	9-9
Control Board Components . . . . .	9-10
Display Board Components . . . . .	9-10
Footswitch Board Components . . . . .	9-13
Power Supply/RF Board Assembly . . . . .	9-16
Parts List . . . . .	9-18
Supply/RF Board Components . . . . .	9-21

# Chapter 1

## Introduction

This manual provides instructions for servicing the Covidien Force FX Electrosurgical Generator C with Instant Response™ technology. This chapter introduces the features and components of the generator and reviews the precautions associated with generator repair.

## General Description

The Covidien Force FX Electrosurgical Generator C is an isolated output electrosurgical generator that provides the appropriate power for cutting, desiccating, and fulgurating tissue during bipolar and monopolar surgery.

It includes the following features:

- Instant Response technology
- Three bipolar modes: precise (low), standard (medium), and macro (macrobipolar)
- Three monopolar cut modes: low, pure, and blend
- Three monopolar coag modes: desiccate (low), fulgurate (medium), and spray (high)
- Support for simultaneous coagulation
- The REM™ Contact Quality Monitoring System
- Support for ultrasonic electrosurgery using the CUSA EXcel™ system and a CUSA™ handpiece with a CUSA electrosurgical module (CEM™) nosecone
- Handswitch or footswitch activation
- Recall of most recently used mode and power settings
- Adjustable activation tone volume
- An RF activation port, RS-232 serial port, and expansion port
- Valleylab™ Argon Gas Delivery Unit II system compatibility

## List of Components

The Force FX Electrosurgical Generator C is a self-contained unit, consisting of a main enclosure (cover and base) and power cord.

The main components of the generator are the following:

- Front panel components—power switch; controls for setting the modes and output power; a button for recalling the power settings and modes that were used last; receptacles for connecting electrosurgical accessories; and indicators that alert you to the current settings and patient return electrode status.
- Rear panel components—volume control; three footswitch receptacles; power entry module; equipotential grounding lug; and three ports (serial port, RF activation port, and expansion port).
- Internal components—Control (microcontroller) board; Display board; Footswitch board; Power Supply/Radio Frequency (RF) board; low voltage power supply; fan; and heat sinks.

A handle is located on the underside of the chassis.

For details about the interaction of the main components and circuit board descriptions, refer to Chapter 4, *Principles of Operation*.

## Service Personnel Safety

Before servicing the generator, it is important that you read, understand, and follow the instructions supplied with it and with any other equipment used to install, test, adjust, or repair the generator.

### General

#### Warning

Use the generator only if the self-test has been completed as described. Otherwise, inaccurate power outputs may result.

The instrument receptacles on this generator are designed to accept only one instrument at a time. Do not attempt to connect more than one instrument at a time into a given receptacle. Doing so will cause simultaneous activation of the instruments.

#### Precaution

Do not stack equipment on top of the generator or place the generator on top of electrical equipment (except a Valleylab Argon Gas Delivery Unit II or a CUSA EXcel unit). These configurations are unstable and/or do not allow for adequate cooling.

Provide as much distance as possible between the electrosurgical generator and other electronic equipment (such as monitors). An activated electrosurgical generator may cause interference with them.

Do not turn the activation tone down to an inaudible level. The activation tone alerts the surgical team when an accessory is active.

#### Notice

If required by local codes, connect the generator to the hospital equalization connector with an equipotential cable.

Connect the power cord to a wall receptacle having the correct voltage. Otherwise, product damage may result.

### Active Accessories

#### Warning

**Electric Shock Hazard** Do not connect wet accessories to the generator.

**Electric Shock Hazard** Ensure that all accessories and adapters are correctly connected and that no metal is exposed.

#### Precaution

Accessories must be connected to the proper receptacle type. In particular, bipolar accessories must be connected to the Bipolar Instrument receptacle only. Improper connection may result in inadvertent generator activation or a REM contact quality monitor alarm.

Set power levels to the lowest setting before testing an accessory.

#### Notice

During bipolar electrosurgery, do not activate the generator until the forceps have made contact with the patient. Product damage may occur.

## Patient Return Electrodes

#### Warning

Using a patient return electrode without the REM safety feature will not activate the REM Contact Quality Monitoring System.

## Fire/Explosion Hazards

#### Warning

**Danger: Explosion Hazard** Do not install the generator in the presence of flammable anesthetics, gases, liquids, or objects.

**Fire Hazard** Do not place active accessories near or in contact with flammable materials (such as gauze or surgical drapes). Electrosurgical accessories that are activated or hot from use can cause a fire. Use a holster to hold electrosurgical accessories safely away from personnel and flammable materials.

**Fire Hazard** Do not use extension cords.

**Fire Hazard** For continued protection against fire hazard, replace fuses only with fuses of the same type and rating as the original fuse.

## Electric Shock Hazards

#### Warning

Connect the generator power cord to a properly grounded receptacle. Do not use power plug adapters.

Do not connect a wet power cord to the generator or to the wall receptacle.

To allow stored energy to dissipate after power is disconnected, wait at least five minutes before replacing parts.

**Warning**

Always turn off and unplug the generator before cleaning.

Do not touch any exposed wiring or conductive surfaces while the generator is disassembled and energized. Never wear a grounding strap when working on an energized generator.

When taking measurements or troubleshooting the generator, take appropriate precautions, such as using isolated tools and equipment, using the "one hand rule," etc.

Potentially lethal AC and DC voltages are present in the AC line circuitry, high voltage DC circuitry, and associated mounting and heat sink hardware described in this manual. They are not isolated from the AC line. Take appropriate precautions when testing and troubleshooting this area of the generator.

High frequency, high voltage signals that can cause severe burns are present in the RF output stage and in the associated mounting and heat sink hardware described in this manual. Take appropriate precautions when testing and troubleshooting this area of the generator.

## Servicing

**Precaution**

Read all warnings, cautions, and instructions provided with this generator before servicing.

The generator contains electrostatic-sensitive components. When repairing the generator, work at a static-control workstation. Wear a grounding strap when handling electrostatic-sensitive components, except when working on an energized generator. Handle circuit boards by their nonconductive edges. Use an antistatic container for transport of electrostatic-sensitive components and circuit boards.

**Notice**

After installing a new low voltage power supply, verify that the voltages are correct.

## Calibration

**Precaution**

To avoid inadvertent coupling and/or shunting of RF currents around the resistor elements, keep the resistors at least 4" (10.2 cm) away from any metal surface including tabletops and other resistors. This is especially true if several resistors are connected in series or parallel to obtain a specified value. Do not allow the resistor bodies to touch each other.

**Notice**

After completing any calibration step, proceed to the next step to save the values from the completed calibration step.

Do not activate the generator with any load resistor higher than 10 ohms (10  $\Omega$ ) while calibrating the current sense gain. Otherwise, product damage will result.

**Notice**

Do not activate the generator with any load resistor lower than 1000  $\Omega$  while calibrating the voltage sense gain for bipolar output. Otherwise, product damage will result.

Do not activate the generator with any load resistor lower than 3000  $\Omega$  while calibrating the voltage sense gain for the Low and Pure cut modes. Do not activate the generator with any load resistor lower than 2000  $\Omega$  while calibrating the voltage sense gain for the Blend mode. Otherwise, product damage will result.

Do not adjust the current sense gain (I factor), the voltage sense gain (V factor), or the reactance gain (Z factor) while the generator is activated.

After calibration, the generator will be ready to use only after you initiate the internal self-test by turning the generator off, then on.

Calibrate the generator after you install a new battery. Calibration values are lost when the battery is replaced.

Calibrate the generator after you install a new Control board. Otherwise, the default calibration values are used.

Calibrate the generator after you install a new heat sink or replace components on the heat sink. Component differences may affect output waveforms.

Calibrate the generator after you install a new Power Supply/RF board. Component differences may affect output waveforms.

## Cleaning

**Notice**

Do not clean the generator with abrasive cleaning or disinfectant compounds, solvents, or other materials that could scratch the panels or damage the generator.

# Chapter 2

## **Controls, Indicators, and Receptacles**

This chapter describes the front and rear panels, including all controls, indicators, receptacles, the fuse drawer, and ports.

# Front Panel

*Layout of controls and indicators on the front panel*

**Recall button**

Pressing this button sets the generator to the most recently used mode and power settings.

**REM alarm indicator**

**CEM indicator**

**Bipolar controls**

**Cut controls**

**Coag controls**

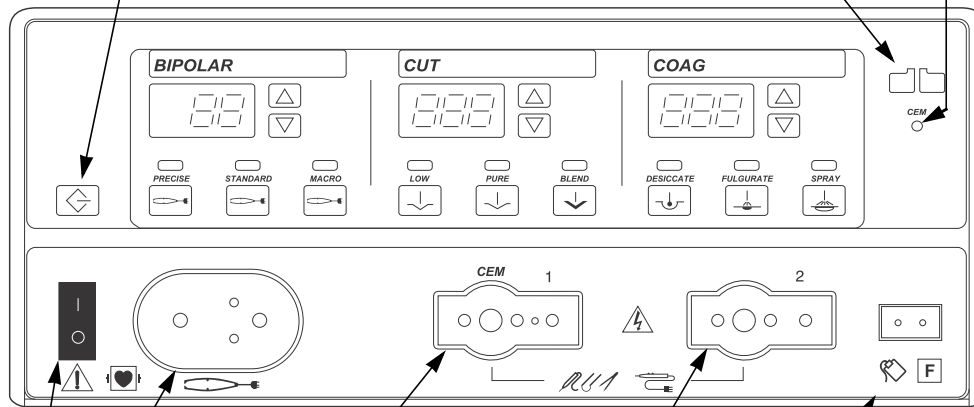

**Bipolar instrument receptacle**

**Monopolar 1/CEM instrument receptacle**

**Monopolar 2 instrument receptacle**

**Power switch**

This switch supplies power to the generator.

**Patient return electrode receptacle**

For monopolar electrosurgery, connect a patient return electrode to this receptacle.

To turn on the generator, press (I).  
To turn off the generator, press (O).

## Bipolar Controls

### Buttons and indicators for bipolar controls

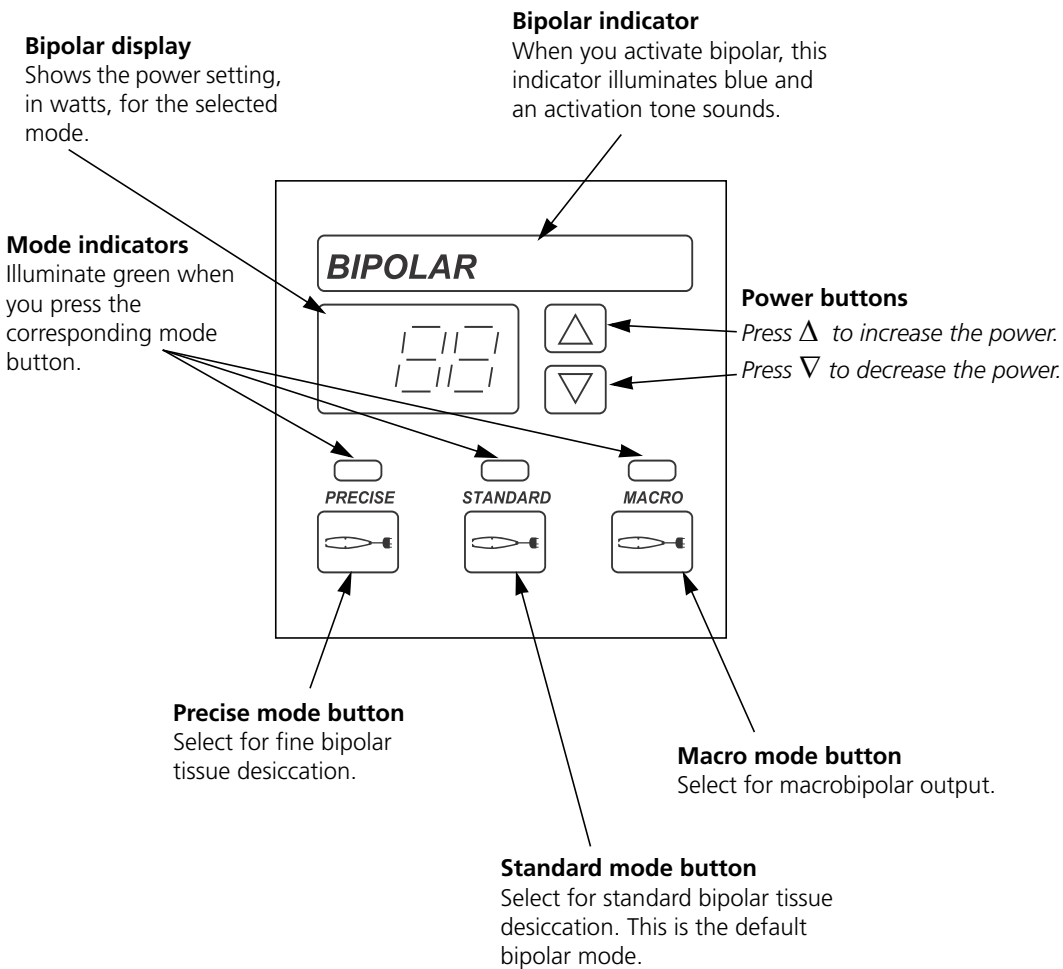

## Bipolar Instrument Receptacle

### Precaution

Connect accessories to the proper receptacle type. In particular, bipolar accessories must be connected to the Bipolar Instrument receptacle only. Improper connection may result in inadvertent generator activation or a REM contact quality monitor alarm.

You can connect either a footswitching or handswitching bipolar instrument to the Bipolar instrument receptacle.

Connect a footswitching instrument with a two-pin connector.

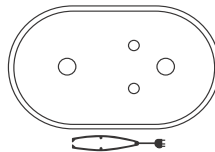

**or**

Connect a handswitching instrument with a three-pin connector.

# Monopolar Cut Controls

## Buttons and indicators for cut controls (monopolar)

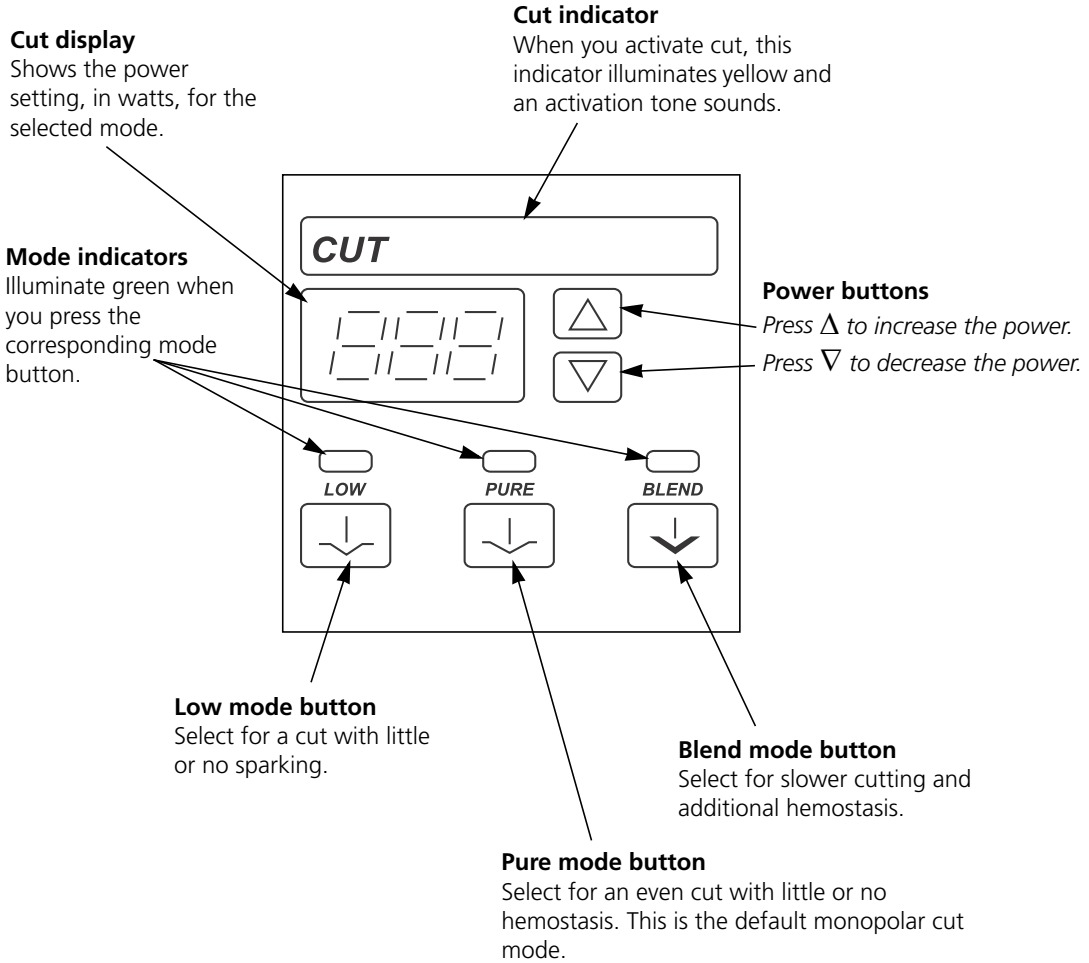

Controls, Indicators,  
and Receptacles

## Monopolar Coag Controls

### Buttons and indicators for coag controls (monopolar)

#### Coag display

Shows the power setting, in watts, for the selected mode.

#### Coag indicator

When you activate coag, this indicator illuminates blue and an activation tone sounds.

#### Mode indicators

Illuminate green when you press the corresponding mode button.

#### Power buttons

Press  $\Delta$  to increase the power.

Press  $\nabla$  to decrease the power.

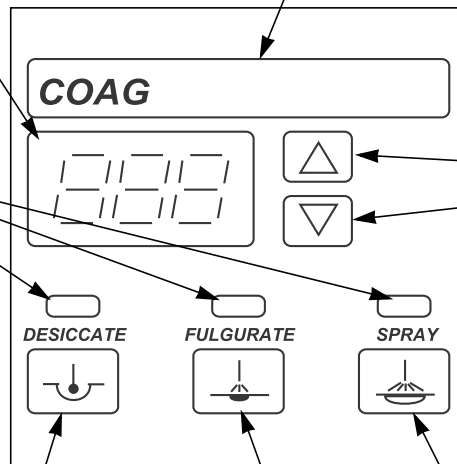

#### Desiccate mode button

Select to desiccate the area of tissue that is in direct contact with the active electrode.

#### Spray mode button

Select to evenly coagulate a wide area of tissue with a spray of sparks; penetration is shallower and tissue area is larger than in fulgurate mode.

#### Fulgurate mode button

Select to fulgurate an area of tissue with a spray of sparks.

This unit is equipped with an additional fulgurate mode which incorporates a lower crest factor (LCF) than the factory default fulgurate mode. For details about this additional fulgurate mode, LCF Fulgurate, refer to Chapter 4, Before Surgery, in the *Force FX Electrosurgical Generator C User's Guide*.

Fulgurate is the default monopolar coag mode. However, the default coag mode can be changed to either Desiccate or Spray through the serial port on the rear panel.

## Monopolar Instrument Receptacles

### Warning

The instrument receptacles on this generator are designed to accept only one instrument at a time. Do not attempt to connect more than one instrument at a time into a given receptacle. Doing so will cause simultaneous activation of the instruments.

You can connect a footswitching or handswitching monopolar instrument to the monopolar receptacles. Some footswitching instruments may require a single-pin adapter (E0502 Series or E0017), available from Covidien.

Connect one monopolar instrument to the Monopolar 1/CEM Instrument receptacle:

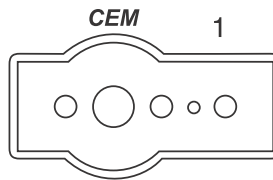

- A single-pin footswitching instrument or a three-pin handswitching instrument
- **or**
- A four-pin CUSA handpiece with CEM nosecone. (The CEM indicator in the upper right of the front panel illuminates green.) Refer to *Connecting the CUSA Handpiece with CEM Nosecone* on page 5-11.

Connect one monopolar instrument to the Monopolar 2 Instrument receptacle:

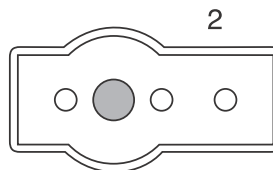

- A single-pin footswitching instrument **or** a three-pin handswitching instrument.

## REM Alarm Indicator

This indicator illuminates red until you properly apply a REM Polyhesive™ Patient Return Electrode to the patient and connect it to the generator. Then the indicator illuminates green. (When you connect an electrode without the REM safety feature, the indicator does not illuminate.)



If the REM system senses an alarm condition, the indicator flashes red until you correct the alarm condition—then the indicator illuminates green. (If you are using a return electrode without the REM safety feature, the red indicator light is extinguished when you correct the alarm condition.)

## Rear Panel

### Controls and receptacles on the rear panel

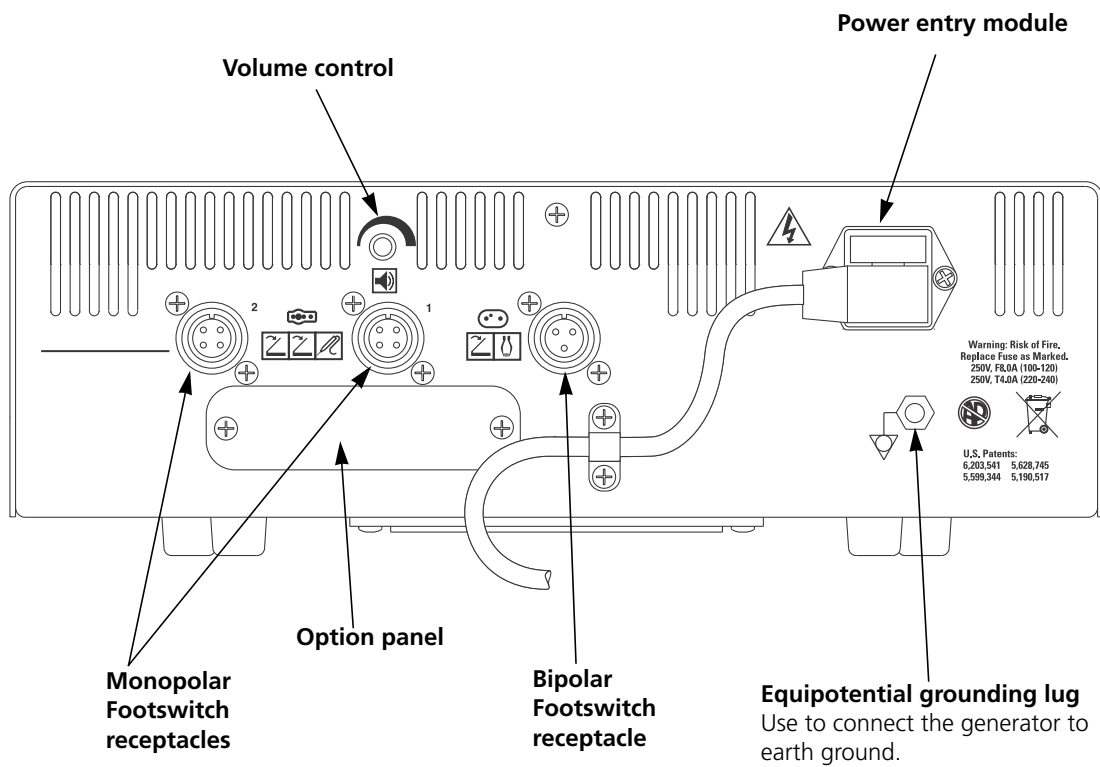

## Footswitch Receptacles

The rear panel contains three footswitch receptacles: two for monopolar and one for bipolar.

### Monopolar Footswitch Receptacles

You must connect a monopolar footswitch if you connect a monopolar footswitching instrument to the generator.

Use only a Valleylab monopolar footswitch with the Force FX Electrosurgical Generator C. Use of an incompatible footswitch may cause unexpected output.

Connect a two-pedal Valleylab monopolar footswitch to the Monopolar 1 Footswitch receptacle.

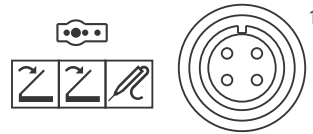

The connected footswitch activates monopolar output for the instrument that is connected to the Monopolar 1/CEM Instrument receptacle on the front panel.

Connect a two-pedal monopolar footswitch to the Monopolar 2 Footswitch receptacle.

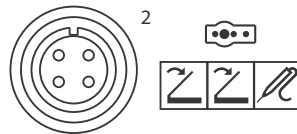

The connected footswitch activates monopolar output for the instrument that is connected to the Monopolar 2 Instrument receptacle on the front panel.

### Bipolar Footswitch Receptacle

You must connect a bipolar footswitch if you connect a bipolar footswitching instrument to the generator.

Connect a single-pedal bipolar footswitch to the Bipolar Footswitch receptacle.

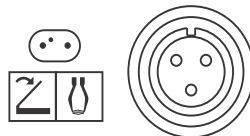

The connected footswitch activates bipolar output for the instrument that is connected to the Bipolar Instrument receptacle on the front panel.

## Power Entry Module

The power entry module consists of a power cord receptacle and a fuse drawer.

### **Components in the power entry module**

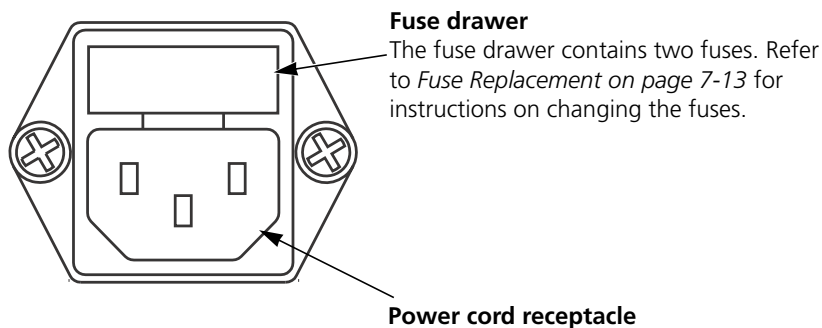

## Activation Tone Volume Control

Turn to adjust the volume of the tones that sound when the generator is activated (activation tone). To ensure that the surgical team is alerted to inadvertent activation, these tones cannot be silenced.



To increase the volume of activation tones, turn the knob clockwise.

To decrease the volume, turn the knob counterclockwise.

## Option Panel

A removable plate on the rear panel covers a serial port, an expansion port, and a radio frequency (RF) activation port. Remove this plate to obtain information through the RS-232 port or to install a peripheral device such as a Bipolar Current Monitor, but retain the original cover plate. After obtaining information or removing a peripheral device, reinstall the original cover plate.

### Precaution

To avoid product damage, do not operate the Force FX Electrosurgical Generator C without an appropriate cover plate in place.

To review the technical specifications for each port, refer to page 3-6 and page 3-7.

### ***The three ports behind the option panel***

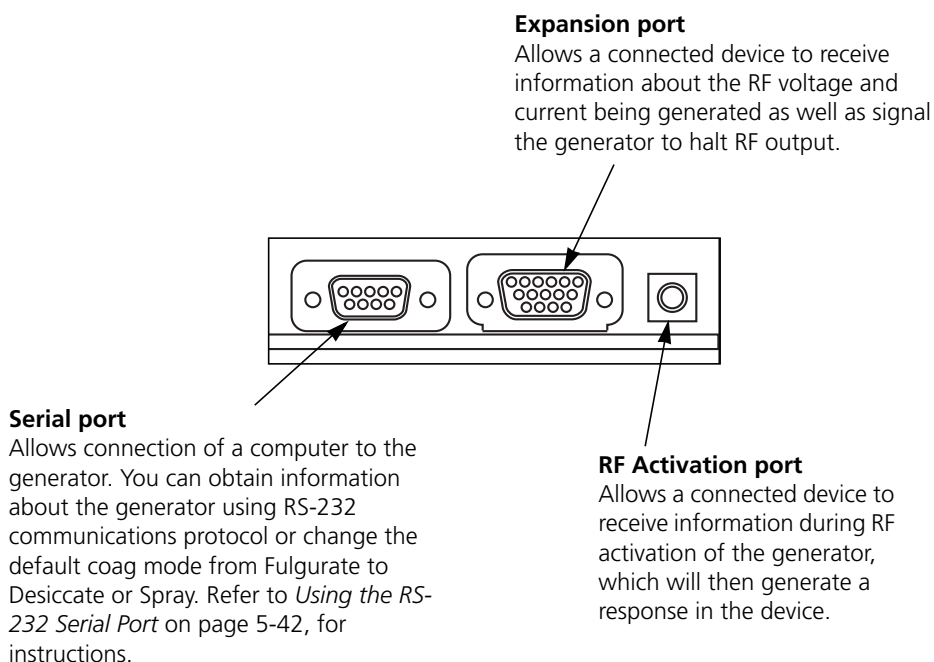



# Chapter 3

## Technical Specifications

All specifications are nominal and subject to change without notice. A specification referred to as "typical" is within  $\pm 20\%$  of a stated value at room temperature (77° F/25° C) and a nominal input power voltage.

## Performance Characteristics

### General

---

<b>Output configuration</b>	Isolated output
<b>Cooling</b>	Natural convection; side and rear panel vents; fan
<b>Display</b>	Eight digital seven-segment displays: 0.75" (1.9 cm) each
<b>Mounting</b>	Universal cart (UC8009), CUSA EXcel System, a Valleylab Argon Gas Delivery Unit II, or any stable flat surface

---

### Dimensions and Weight

---

<b>Width</b>	14" (35.6 cm)
<b>Depth</b>	18" (45.7 cm)
<b>Height</b>	4 3/8" (11.1 cm)
<b>Weight</b>	<18 lb (< 8.2 kg)

---

### Operating Parameters

---

<b>Ambient temperature range</b>	50° to 104° F (10° to 40° C)
<b>Relative humidity</b>	30% to 75%, noncondensing
<b>Atmospheric pressure</b>	700 to 1060 millibars
<b>Warm-up time</b>	If transported or stored at temperatures outside the operating temperature range, allow one hour for the generator to reach room temperature before use.

---

## Transport and Storage

<b>Ambient temperature range</b>	-40° to 158° F (-40° to 70° C)
<b>Relative humidity</b>	25% to 85%, noncondensing
<b>Atmospheric pressure</b>	500 to 1060 millibars
<b>Duration of storage</b>	If stored longer than one year, the battery must be replaced (Refer to Battery Replacement on page 7-3) and a full checkout, including calibration, must be completed before use. For instructions, refer to Chapter 5, <i>Setup, Tests, and Adjustment</i> .

## Duty Cycle

Under maximum power settings and rated load conditions (Pure cut, 300 watt setting, 300  $\Omega$  load) the generator is suitable for activation times of 10 seconds on, 30 seconds off for one hour.

If the internal temperature of the generator is too high, an alarm tone sounds and a number (451) flashes in the Cut display alternately with the power settings. You can activate the generator and change the power settings while this condition exists.

## Internal Memory Audio Volume

---

**Nonvolatile SRAM and  
Battery-backed RTC  
Memory**

A nonvolatile SRAM stores calibration parameters, statistical data, power-on settings, and memory settings on power-down. It is also used for general, temporary data storage by the main microcontroller.

The RTC memory that is used to maintain the time of day and date has 114 bytes of nonvolatile battery-backed RAM that is used as a secondary backup for all the calibration data, power-on settings, and memory settings stored in the NVSRAM.

Battery type: 3 V lithium button cell

Battery life: 5 years

---

**Storage capacity**

One configuration, including three power settings and three mode settings

The last 20 error codes detected by the generator

The number of times and length of activation for each mode

The average power setting used for each mode

The total time the generator is on

Other service-related information.

---

## Audio Volume

The audio levels stated below are for activation tones (bipolar, cut, and coag) and alarm tones (REM and system alarms) at a distance of one meter. Alarm tones meet the requirements for IEC 60601-2-2.

### Activation Tone

<b>Volume (adjustable)</b>	45 to $\geq$ 65 dBA
<b>Frequency</b>	Bipolar: 940 Hz Cut: 660 Hz Coag: 940 Hz Simultaneous Coag: 940 Hz for 400 ms & 660 Hz for 100 ms
<b>Duration</b>	Continuous while the generator is activated

### Alarm Tone

<b>Volume (not adjustable)</b>	$\geq$ 65 dBA
<b>Frequency</b>	660 Hz
<b>Duration</b>	250 to 500 ms

## REM Contact Quality Monitor

REM current is measured according to IEC 60601-1, Ed. 1988, Figure 15.

<b>Measurement frequency</b>	80 kHz $\pm$ 10 kHz
<b>Measurement current</b>	< 10 $\mu$ A

### Acceptable Resistance Range

REM resistance measurements are  $\pm$  10% during RF activation and  $\pm$  5% when RF output is not activated.

REM Polyhesive Patient Return Electrode: 5 to 135  $\Omega$  or up to a 40% increase in the initial measured contact resistance (whichever is less).

Patient return electrode without the REM safety feature (single section electrode): 0 to 20  $\Omega$ .

If the measured resistance is outside the acceptable range(s) noted above, a REM fault condition occurs.

### REM Alarm Activation

**REM Polyhesive Patient Return Electrode:** When the measured resistance exceeds the standard range of safe resistance (below 5  $\Omega$  or above 135  $\Omega$ ) or when the initial measured contact resistance increases by 40% (whichever is less), the REM Alarm indicator flashes red, a tone sounds twice, and RF output is disabled. The indicator remains illuminated red until you correct the condition causing the alarm. Then, the indicator illuminates green and RF output is enabled.

**Patient return electrode without the REM safety feature:** When the measured resistance between the patient return electrode pins exceeds 20  $\Omega$ , the REM Alarm indicator flashes red, a tone sounds twice, and RF output is disabled. The indicator remains illuminated red until you correct the condition causing the alarm. Then, the red indicator is extinguished and RF output is enabled.

## Serial Port

RS-232 compatible; 9600 baud, 8 data bits, 1 stop bit, no parity

---

<b>9-pin connector supports the following signals</b>	Pin 2—isolated transmit (serial data output transmit line)
	Pin 3—isolated receive (serial data input receive line)
	Pin 5—isolated ground (reference for transmit and receive).

---

## RF Activation Port

The RF activation port is a subminiature telephone jack attached to the contacts of a small relay. The contacts are closed when the output is energized and open at all other times. This port provides a means to tell other equipment that RF current is being generated. This may be useful when making EEG or ECG measurements.

## Expansion Port

<b>15-pin connector; supports the following signals</b>	<ul style="list-style-type: none"> <li>• Pin 2—isolated transmit (serial data output transmit line)</li> <li>• Pin 3—isolated receive (serial data input receive line)</li> <li>• Pin 5—isolated ground (reference for transmit and receive)</li> <li>• Pin 9—RF disable: input signal which, when activated by an external device, disables active RF output</li> <li>• Pin 10—RF current: output signal proportional to active RF current</li> <li>• Pin 11—RF voltage: output signal proportional to active RF voltage.</li> </ul>
<b>Expansion power (from the low voltage power supply)</b>	+ 5 V (pin 6), -12 V (pin 14), + 12 V (pin 15), and ground (pins 12 & 13)

## Low Frequency (50–60 Hz) Leakage Current

<b>Enclosure source current, ground open</b>	< 300 $\mu$ A
<b>Source current, patient leads, all outputs</b>	Normal polarity, intact ground: < 10 $\mu$ A Normal polarity, ground open: < 50 $\mu$ A Reverse polarity, ground open: < 50 $\mu$ A
<b>Sink current at high line, all inputs</b>	< 50 $\mu$ A

## High Frequency (RF) Leakage Current

<b>Bipolar RF leakage current</b>	< 59.2 mA <sub>rms</sub>
<b>Monopolar RF leakage current (additional tolerance)</b>	< 150 mA <sub>rms</sub>
<b>CEM output modes</b>	< 150 mA <sub>rms</sub> at $\leq$ 50 W

## Input Power

100–120 Volt	220–240 Volt
Maximum VA at nominal line Voltage: Idle: 52 VA Bipolar: 450 VA Cut: 924 VA Coag: 530 VA	Maximum VA at nominal line Voltage: Idle: 52 VA Bipolar: 450 VA Cut: 924 VA Coag: 530 VA
Input mains voltage, operating range: 104–132 Vac	Input mains voltage, operating range: 208–264 Vac
Mains current (maximum): Idle: 0.4 A Bipolar: 2.0 A Cut: 7.0 A Coag: 4.0 A	Mains current (maximum): Idle: 0.2 A Bipolar: 1.0 A Cut: 3.5 A Coag: 2.0 A
Mains line frequency range (nominal): 50 to 60 Hz	Mains line frequency range (nominal): 50 to 60 Hz
Fuses (2): F8 A	Fuses (2): T4 A
Power cord: 3-prong hospital grade connector	Power cord: 3-prong locally approved connector

## Power Cord Specification

This unit was equipped from the factory with either a 110VAC hospital grade NEMA 5-15 power cord or a 220VAC CEE7/7 power cord. Should the AC power cord need to be replaced to match another plug configuration, the replacement plug/cable/receptacle configuration must meet or exceed the following specifications:

### 100-120 VAC

Cable - SJT16/3, IEC color code, maximum length 15' (5 m)

Plug - minimum 10 A 125 VAC

Unit receptacle - IEC female, minimum 10 A - 125 VAC







**220-240 VAC**











Cable - H05VVVF3G1.0 VDE, maximum length 15' (5 meters)









Plug - minimum 6 A - 250 VAC

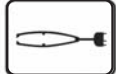









Unit receptacle - IEC female, minimum 6 A - 250 VAC











**Standards and IEC Classifications****Front Panel**



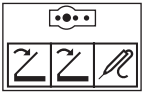



Symbol	Definition	Reference
	Read data from store	ISO 7000-1026
	Recall button	
	Consult instructions for use Indicates the operating instructions should be considered when operating the device	ISO 7000-1641
	Caution Indicates that caution is necessary when operating the device, or to indicate that the current situation needs operator awareness or operator action in order to avoid undesirable consequences	ISO 7000-0434A
	"ON" (power)	IEC 60417-5007
	"OFF" (power)	IEC 60417-5008
	Defibrillation-proof type CF applied part C= cardiac F= floating applied part	IEC 60417-5336

Symbol	Definition	Reference
	Electrosurgery, cutting mode	
	Low cutting mode	IEC 60417-5780
	Pure cutting mode	
<hr/>		
	Electrosurgery, blended cutting mode	
	Blend cutting mode	IEC 60417-5781
<hr/>		
	Electrosurgery, coagulation mode	
	Desiccate coagulation mode	IEC 60417-5782
	Fulgurate coagulation mode	
<hr/>		
	Electrosurgery, spray coagulation mode	
	Spray coagulation mode	IEC 60417-5783
<hr/>		



Symbol	Definition	Reference
	Electrosurgery, bipolar coagulation mode	IEC 60417-5784
	Bipolar mode	
	Caution, risk of electric shock	IEC 60417-6042
	HF isolated patient circuit	IEC 60601-2-2 IEC 1193/06
	Monopolar 1/CEM instrument receptacle	
	Monopolar 2 instrument receptacle	
	Patient return electrode receptacle For monopolar electrosurgery, connect a patient return electrode to this receptacle	
	REM alarm indicator	
<b>Rear Panel</b>		
Symbol	Definition	Reference
	Caution Indicates that caution is necessary when operating the device, or to indicate that the current situation needs operator awareness or operator action in order to avoid undesirable consequences	ISO 7000-0434A

Symbol	Definition	Reference
	Non-anesthetic proof	
	To identify the control by means of which a quantity is increased or decreased	ISO 7000-1364
	Loudspeaker	IEC 60417-5080
	Volume Control	
	Date of manufacture Indicates the date when the medical device was manufactured	IEC 7000-2497
	Manufacturer Indicates the medical device manufacturer, as defined in European Council Directives 90/385/EEC, 93/42/EEC, and 98/79/EC	ISO 7000-3082
	Catalogue number Indicates the manufacturer's catalogue number so that the medical device can be identified	ISO 7000-2493
	Serial number Indicates a serial number so that a specific medical device can be identified	ISO 7000-2498
	Authorized representative in the European community Indicates the authorized representative in the European community	ISO 15223 5.1.2
	Fuse	IEC 60417-5016









Symbol	Definition	Reference
	Equipotential ground	IEC 60417-5021
	Alternating current	IEC 60417-5032
	Not to be used in residential areas	IEC 60417-5109
	Footswitch	IEC 60417-5114
	Monopolar footswitch	
	Footswitch	IEC 60417-5114
	Bipolar footswitch	
	Non-ionizing electromagnetic radiation	IEC 60417-5140
	General limits To identify the activation time duty cycle (10 seconds ON, 30 seconds OFF)	IEC 60417-5649
	Caution, risk of electric shock	IEC 60417-6042



Symbol	Definition	Reference
	WEEE (Waste from electrical and electronic equipment) Dispose of electrical and electronic equipment in compliance with local regulations	WEEE directive
	ETL Listed mark: Medical Electrical Equipment, Systems, & Devices	ETL-Intertek
	Rx only Caution: Federal law restricts this device to sale by or on the order of a (licensed healthcare practitioner)	FDA
	GOST mark Russian approval	GOST
	CE marking	
	Not made with natural rubber latex	

**Inside Enclosure**

Symbol	Definition	Reference
	Caution Indicates that caution is necessary when operating the device, or to indicate that the current situation needs operator awareness or operator action in order to avoid undesirable consequences	ISO 7000-0434A
	Protective earth ground	IEC 60417-5019
	Caution, risk of electric shock	IEC 60417-6042

## Shipping Box

Symbol	Definition	Reference
 Temperature limit	Temperature limit Indicates the temperature limits to which the medical device can be safely exposed	ISO 7000-0632
 Humidity limitation	Humidity limitation Indicates the range of humidity to which the medical device can be safely exposed	ISO 7000-2620
	Rx only Caution: Federal law restricts this device to sale by or on the order of a (licensed healthcare practitioner)	FDA
	GOST mark Russian approval	GOST
	CE marking	
	Not made with natural rubber latex	
	Date of manufacture Indicates the date when the medical device was manufactured	IEC 7000-2497
	Manufacturer Indicates the medical device manufacturer, as defined in European Council Directives 90/385/EEC, 93/42/EEC, and 98/79/EC	ISO 7000-3082
	Catalogue number Indicates the manufacturer's catalogue number so that the medical device can be identified	ISO 7000-2493

Symbol	Definition	Reference
	Serial number Indicates a serial number so that a specific medical device can be identified	ISO 7000-2498
	Authorized representative in the European community Indicates the authorized representative in the European community	ISO 15223 5.1.2
	Consult instructions for use Indicates the operating instructions should be considered when operating the device	ISO 7000-1641

## Class I Equipment (IEC 60601-1)

Accessible conductive parts cannot become live in the event of a basic insulation failure because of the way in which they are connected to the protective earth conductor.

## Type CF Equipment (IEC 60601-1)/Defibrillator Proof



The Force FX Electrosurgical Generator C provides a high degree of protection against electric shock, particularly regarding allowable leakage currents. It is type CF isolated (floating) output and may be used for procedures involving the heart.

The Force FX Electrosurgical Generator C patient return electrode terminal is protected from defibrillator discharge according to ANSI/AAMI HF18 and IEC 60601-2-2.

## Liquid Spillage

The Force FX Electrosurgical Generator C enclosure is constructed so that liquid spillage in normal use does not wet electrical insulation or other components which when wetted are likely to adversely affect the safety of the equipment.

## Electromagnetic Interference

When placed on or beneath an activated Valleylab electro-surgical generator, the Force FX Electro-surgical Generator C operates without interference. The generator minimizes electromagnetic interference to video equipment used in the operating room.

## Electromagnetic Compatibility

The Force FX Electro-surgical Generator C complies with the appropriate IEC 60601-1-2 and IEC 60601-2-2 specifications regarding electromagnetic compatibility.

### Notice

The Force FX Electro-surgical Generator C should not be used adjacent to or stacked with equipment other than specified in the *Force FX Electro-surgical Generator C User Guide and Service Manual*. If adjacent or stacked use is necessary, the Force FX Electro-surgical Generator C should be observed to verify normal operation in the configuration in which it will be used.

The Force FX Electro-surgical Generator C intentionally applies RF energy for diagnosis or treatment during activation. Observe other electronic medical equipment in the vicinity during the Force FX Electro-surgical Generator C activation for any possible adverse electromagnetic effects. Ensure adequate separation of electronic medical equipment based on observed reactions.

## Cables Used for the Force FX EMC Test

Force FX EMC Test—Cables Used			
Model	Function	Length	Location
207002060	AC cable	15 ft.	Rear panel
Multicontact Part Number: 15.2013-46020	Equipotential cable	15 ft.	Rear panel
E2450HDBNSB	Two-button pencil	15 ft.	Front panel mono 1
E2450HDBNSB	Two-button pencil	15 ft.	Front panel mono 2
E7507DB	Adult REM pad	15 ft.	Front panel REM
E0020V / E4073CT	Foot switching bipolar cord / bayonet forceps	15 ft.	Front panel bipolar
E6019	Dome bipolar footswitch	15 ft.	Rear panel bipolar
E6008B	Monopolar footswitch	15 ft.	Rear panel mono 1
E6008B	Monopolar footswitch	15 ft.	Rear panel mono 2
VLCM	Bipolar current monitor	24 ft.	Rear panel
EA3730	EKG blanking cable	5 ft.	Rear panel

**Warning:** The use of accessories, other than specified in the Force FX-C User's Guide and Service Manual, may result in increased emissions or decreased immunity of the Force FX-C generator.

Only the use of Covidien-branded monopolar cables and accessories, bipolar cables and accessories, and footswitches are approved for use with the Force FX generator. Use of non-Covidien-branded cables and accessories have not been assessed and therefore do not comply with the safety and EMC requirements of IEC 60601-1, IEC 60601-1-2, and/or IEC 60601-2-2.

## Voltage Transients (Emergency Generator Mains Transfer)

The Force FX Electrosurgical Generator C operates in a safe manner when the transfer is made between line AC and an emergency generator voltage source.

<b>Guidance and manufacturer's declaration - electromagnetic emissions</b>		
The Force FX Electrosurgical Generator C is intended for use in the electromagnetic environment specified below. The customer or the user of the Force FX Electrosurgical Generator C should ensure that it is used in such an environment.		
<b>Emissions test</b>	<b>Compliance</b>	<b>Electromagnetic environment - guidance</b>
RF emissions CISPR 11	Group 1	The Force FX Electrosurgical Generator C uses RF energy only for its internal function. Therefore, its RF emissions are very low and are not likely to cause any interference in nearby electronic equipment.
RF emissions CISPR 11	Class A	The Force FX Electrosurgical Generator C is suitable for use in all establishments other than domestic and those directly connected to the public low-voltage power supply network that supplies buildings used for domestic purposes.
Harmonic emissions IEC 61000-3-2	Class A	
Voltage fluctuations/ flicker emissions IEC61000-3-3	Complies	

<b>Guidance and manufacturer's declaration - electromagnetic immunity</b>			
The Force FX Electrosurgical Generator C is intended for use in the electromagnetic environment specified below. The customer or the user of the Force FX Electrosurgical Generator C should ensure that it is used in such an environment.			
<b>Immunity test</b>	<b>IEC 60601 test level</b>	<b>Compliance level</b>	<b>Electromagnetic environment - guidance</b>
Electrostatic discharge (ESD) IEC 61000-4-2	+/-6 kV contact +/-8 kV air	+/-6 kV contact +/-8 kV air	Floors should be wood, concrete or ceramic tile. If floors are covered with synthetic material, the relative humidity should be at least 30%.
Electrical fast transient/burst IEC 61000-4-4	+/-2 kV for power supply lines +/-1 kV for input/output lines	+/-2 kV for power supply lines +/-1 kV for input/output lines	Mains power quality should be that of a typical commercial or hospital environment.
Surge IEC 61000-4-5	+/-1 kV differential mode +/-2 kV common mode	+/-1 kV differential mode +/-2 kV common mode	Mains power quality should be that of a typical commercial or hospital environment.
Voltage dips, short interruptions and voltage variations on power supply input lines IEC 61000-4-11	<5% Ut (>95% dip in Ut) for 0,5 cycle 40% Ut (>60% dip in Ut) for 5 cycles 70% Ut (>30% dip in Ut) for 25 cycles <5% Ut (>95% dip in Ut) for 5 sec	<5% Ut (>95% dip in Ut) for 0,5 cycle 40% Ut (>60% dip in Ut) for 5 cycles 70% Ut (>30% dip in Ut) for 25 cycles <5% Ut (>95% dip in Ut) for 5 sec	Mains power quality should be that of a typical commercial or hospital environment. If the user of the Force FX Electrosurgical Generator C requires continued operation during power mains interruptions, it is recommended that the Force FX Electrosurgical Generator C be powered from an uninterruptible power supply or a battery.
Power frequency (50/60 Hz) magnetic field IEC 61000-4-8	3 A/m	3 A/m	Power frequency magnetic fields should be at levels characteristic of a typical location in a typical commercial or hospital environment.
<b>NOTE:</b> Ut is the a.c. mains voltage prior to the application of the test level.			

<b>Guidance and manufacturer's declaration - electromagnetic immunity</b>			
The Force FX Electrosurgical Generator C is intended for use in the electromagnetic environment specified below. The customer or the user of the Force FX Electrosurgical Generator C should ensure that it is used in such an environment.			
<b>Immunity test</b>	<b>IEC 60601 test level</b>	<b>Compliance level</b>	<b>Electromagnetic environment - guidance</b>
Conducted RF IEC 61000-4-6	3 Vrms 150KHz to 80MHz	7 V	<p>Portable and mobile RF communications equipment should be used no closer to any part of the Force FX Electrosurgical Generator C, including cables, than the recommended separation distance calculated from the equation applicable to the frequency of the transmitter.</p> <p><b>Recommended separation distance</b></p> $d=0.5\sqrt{P}$ $d=0.5\sqrt{P} \text{ 80MHz to 800MHz}$ $d=\sqrt{P} \text{ 800MHz to 2.5GHz}$ <p>Where P is the maximum output power rating of the transmitter in watts (W) according to the transmitter manufacturer and d is the recommended separation distance in meters (m).</p> <p>Field strengths from fixed RF transmitters, as determined by an electromagnetic site survey, should be less than the compliance level in each frequency range.</p> <p>Interference may occur in the vicinity of equipment marked with the following symbol:</p> 
Radiated RF IEC 61000-4-3	3 V/m 80MHz to 2.5GHz	7 V/m	
<p><b>NOTE 1</b> At a 80MHz and 800MHz, the higher frequency range applies.</p> <p><b>NOTE 2</b> These guidelines may not apply in all situations. Electromagnetic propagation is affected by absorption and reflection from structures, objects and people.</p>			

- a. Field strengths from fixed transmitters, such as base stations for radio (cellular/cordless) telephones and land mobile radios, amateur radio, AM and FM radio broadcast and TV broadcast cannot be predicted theoretically with accuracy. To assess the electromagnetic environment due to fixed RF transmitters, an electromagnetic site survey should be considered. If the measured field strength in the location in which the Force FX Electrosurgical Generator C is used exceeds the applicable RF compliance level above, the Force FX Electrosurgical Generator C should be observed to verify normal operation. If abnormal performance is observed, additional measures may be necessary, such as reorienting or relocating the Force FX Electrosurgical Generator C.
- b. Over the frequency range 150kHz to 80MHz, field strengths should be less than 7V/m.

**Recommended separation distances between portable and mobile RF communication equipment and the Force FX Electrosurgical Generator C**

The Force FX Electrosurgical Generator C is intended for use in an electromagnetic environment in which radiated RF disturbances are controlled. The Customer or the user of the Force FX Electrosurgical Generator C can help prevent electromagnetic interferences by maintaining a minimum distance between portable and mobile RF communications equipment (transmitters) and the Force FX Electrosurgical Generator C as recommended below, according to the maximum output power of the communications equipment.

Rated maximum output power of transmitter (W)	Separation distance according to frequency of transmitter (m)		
	150 kHz to 80MHz $d=0.5\sqrt{P}$	80MHz to 800MHz $d=0.5\sqrt{P}$	800MHz to 2.5GHz $d=\sqrt{P}$
0.01	0.05 m	0.05 m	0.1 m
0.1	0.16 m	0.16 m	0.32 m
1	0.5 m	0.5 m	1 m
10	1.6 m	1.6 m	3.2 m
100	5 m	5 m	10 m

For transmitters rated at a maximum output power not listed above, the recommended separation distance  $d$  in meters (m) can be estimated using the equation applicable to the frequency of the transmitter, where  $P$  is the maximum output power rating of the transmitter in watts (W) according to the transmitter manufacturer.

- NOTE 1** At a 80MHz and 800MHz, the separation distance for the higher frequency range applies.
- NOTE 2** These guidelines may not apply in all situations. Electromagnetic propagation is affected by absorption and reflection from structures, objects and people.

## Output Characteristics

### Maximum Output for Bipolar and Monopolar Modes

Power readouts agree with actual power into rated load to within 15% or 5 W, whichever is greater.

Mode	Open Circuit P-P Voltage (max)	Rated Load (max)	Power (max)	Crest Factor <sup>+</sup>
<b>Bipolar</b>				
<i>Precise</i>	450 V	100 $\Omega$	70 W	1.5
<i>Standard</i>	320 V	100 $\Omega$	70 W	1.5
<i>Macro</i>	750 V	100 $\Omega$	70 W	1.5
<b>Monopolar Cut</b>				
<i>Low</i>				
<i>Pure</i>	1350 V	300 $\Omega$	300 W	1.5
<i>Blend</i>	2300 V	300 $\Omega$	300 W	1.5
	3300 V	300 $\Omega$	200 W	2.5
<b>Monopolar Coag</b>				
<i>Desiccate</i>	3500 V	500 $\Omega$	120 W	5.0
<i>Fulgurate</i>	8500 V	500 $\Omega$	120 W	7.0
<i>LCF Fulgurate</i>	6900 V	500 $\Omega$	120 W	5.5
<i>Spray</i>	9000 V	500 $\Omega$	120 W	8.0

\* Power Efficiency Rating indicates the ability of an electrosurgical generator to deliver the selected power over a wide range of tissue impedances. PER value is approximate.

+ An indication of a waveform's ability to coagulate bleeders without a cutting effect

## Maximum Output for Ultrasonic Electrosurgery

Mode	Open Circuit P-P Voltage (max)	Rated Load (max)	Power (max)	Crest Factor <sup>+</sup>
<b>Monopolar Cut</b>				
<i>Low</i>	1000 V	300 Ω	100 W	1.5
<b>Monopolar Coag</b>				
<i>Desiccate</i>	3500 V	500 Ω	70 W	5.0

*+ An indication of a waveform's ability to coagulate bleeders without a cutting effect*

## Available Power Settings in Watts

### Bipolar and Macrobipolar

1	2	3	4	5	6	7	8	9	10
11	12	13	14	15	16	17	18	19	20
21	22	23	24	25	26	27	28	29	30
31	32	33	34	35	36	37	38	39	40
45	50	55	60	65	70				

### Monopolar Cut: Low and Pure

1	2	3	4	5	6	7	8	9	10
11	12	13	14	15	16	17	18	19	20
21	22	23	24	25	26	27	28	29	30
31	32	33	34	35	36	37	38	39	40
45	50	55	60	65	70	75	80	85	90
95	100	110	120	130	140	150	160	170	180
190	200	210	220	230	240	250	260	270	280
290	300								

**Monopolar Cut: Blend**

1	2	3	4	5	6	7	8	9	10
11	12	13	14	15	16	17	18	19	20
21	22	23	24	25	26	27	28	29	30
31	32	33	34	35	36	37	38	39	40
45	50	55	60	65	70	75	80	85	90
95	100	110	120	130	140	150	160	170	180
190	200								

**Monopolar Coag**

1	2	3	4	5	6	7	8	9	10
11	12	13	14	15	16	17	18	19	20
21	22	23	24	25	26	27	28	29	30
31	32	33	34	35	36	37	38	39	40
45	50	55	60	65	70	75	80	85	90
95	100	110	120						

**CEM Cut**

1	2	3	4	5	6	7	8	9	10
11	12	13	14	15	16	17	18	19	20
21	22	23	24	25	26	27	28	29	30
31	32	33	34	35	36	37	38	39	40
45	50	55	60	65	70	75	80	85	90
95	100								

**CEM Coag**

1	2	3	4	5	6	7	8	9	10
11	12	13	14	15	16	17	18	19	20
21	22	23	24	25	26	27	28	29	30
31	32	33	34	35	36	37	38	39	40
45	50	55	60	65	70				

## Output Waveforms

Instant Response technology, an automatic adjustment, controls all bipolar modes and all cut modes. It does not control the coag modes because of their fulguration capabilities. For more information, refer to Chapter 4, *Instant Response Technology* and *Instant Response Algorithm*.

### Bipolar

<i>Precise</i>	470 kHz sinusoid
<i>Standard</i>	470 kHz sinusoid
<i>Macro</i>	470 kHz sinusoid

### Monopolar Cut

<i>Low</i>	390 kHz sinusoid. Similar to the Pure cut mode except the maximum voltage is limited to a lower value.
<i>Pure</i>	390 kHz sinusoid
<i>Blend</i>	390 kHz bursts of sinusoid, recurring at 27 kHz intervals. 50% duty cycle.

### Monopolar Coag

<i>Desiccate</i>	240 kHz sinusoid repeated at 39 kHz. 8% duty cycle
<i>Fulgurate</i>	470 kHz damped sinusoidal bursts with a repetition frequency of 30 kHz into 500 $\Omega$
<i>LCF Fulgurate</i>	470 kHz damped sinusoidal bursts with a repetition frequency of 57 kHz into 500 $\Omega$
<i>Spray</i>	390 kHz sinusoidal bursts with a randomized repetition centered at 28 kHz. Frequencies include 21 kHz < f < 35 kHz. Output is further modulated by a random 250 Hz envelope with a variable duty cycle.

## Output Power vs. Resistance Graphs

The graphs that follow depict the changes for each mode at specific power settings.

**Note:** These curves represent the lower and upper limits of output power with tolerance included. The normal output power will be halfway between these two curves.

### Bipolar Graphs

The insulating surface described in IEC 60601-2-2 was used to obtain the bipolar output measurements.

#### Precise Bipolar Mode

**Output power vs. impedance for Precise bipolar 35W mode**

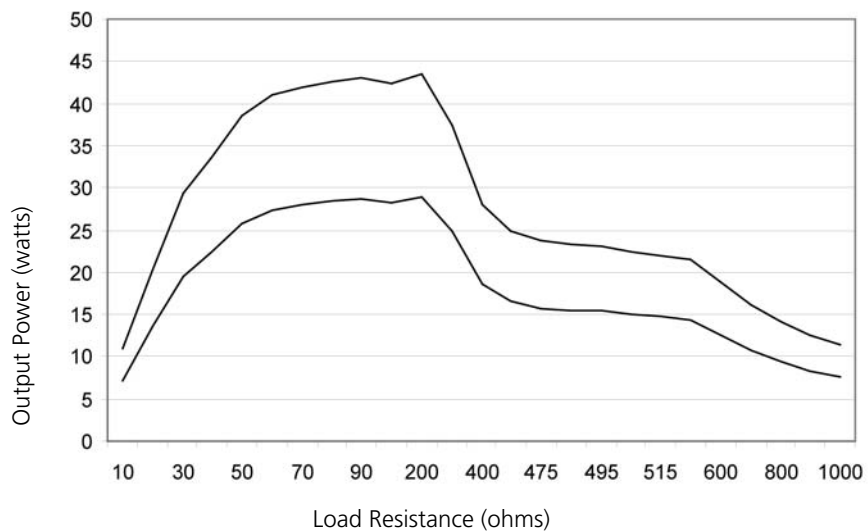

**Output power vs. impedance for Precise bipolar 70W mode**

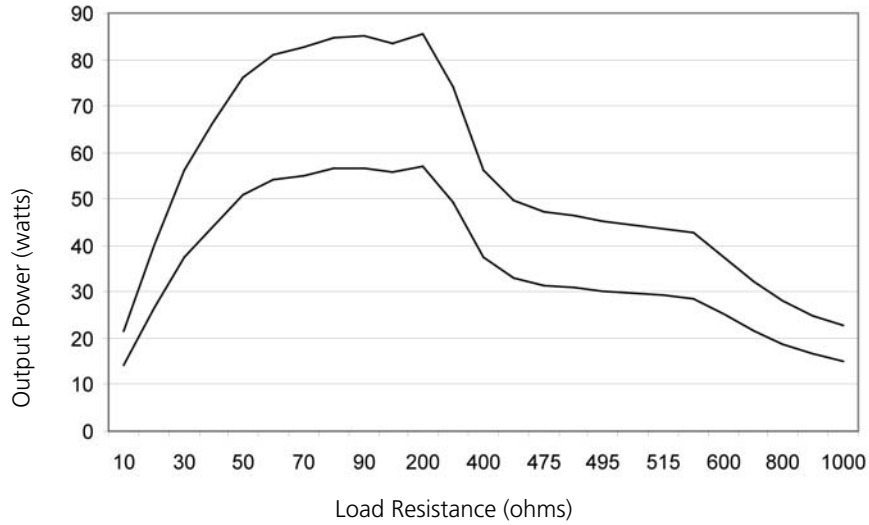

**Open circuit peak voltage vs. output power for Precise bipolar mode**

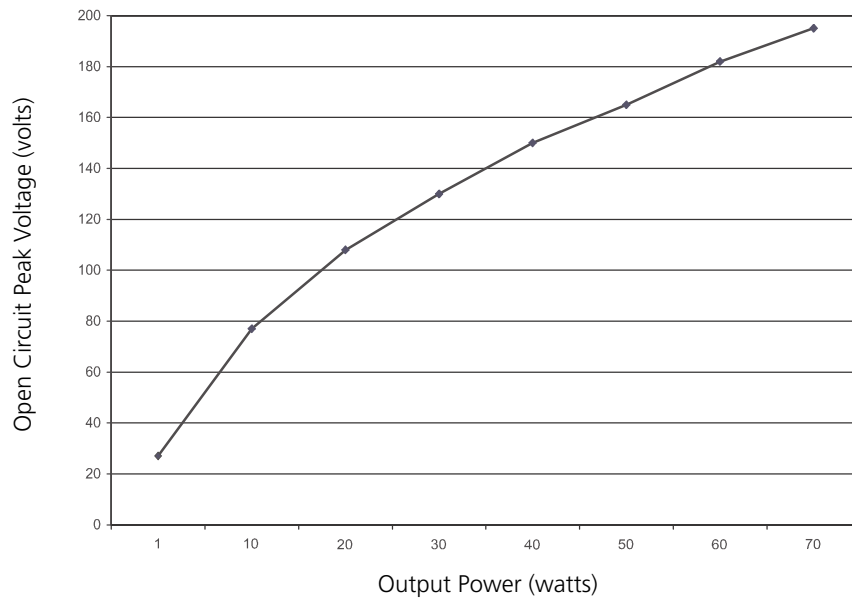

**Output power vs. generator settings Precise bipolar mode**

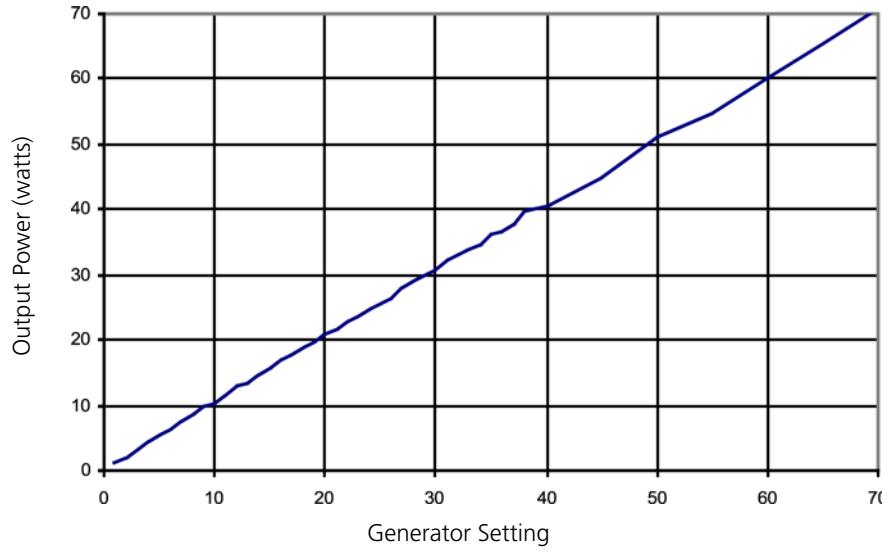

## Standard Bipolar Mode

**Output power vs. impedance for Standard bipolar 35W mode**

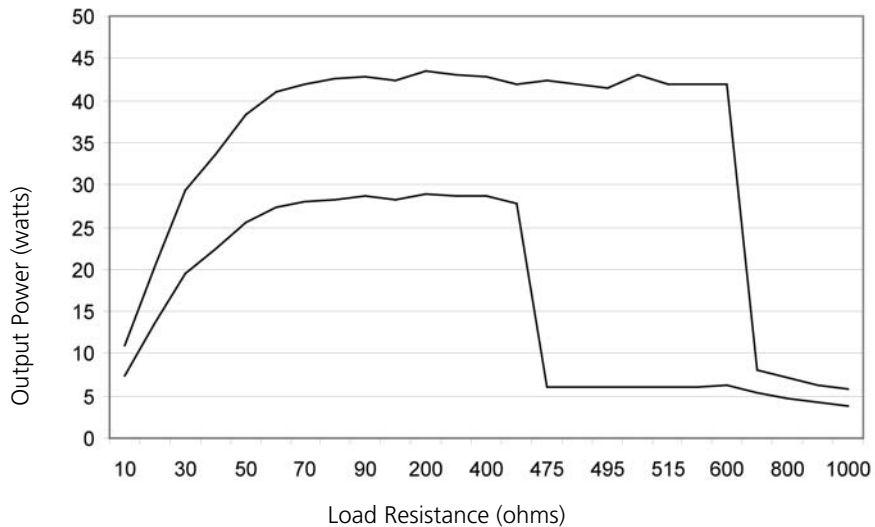

**Output power vs. impedance for Standard bipolar 70W mode**

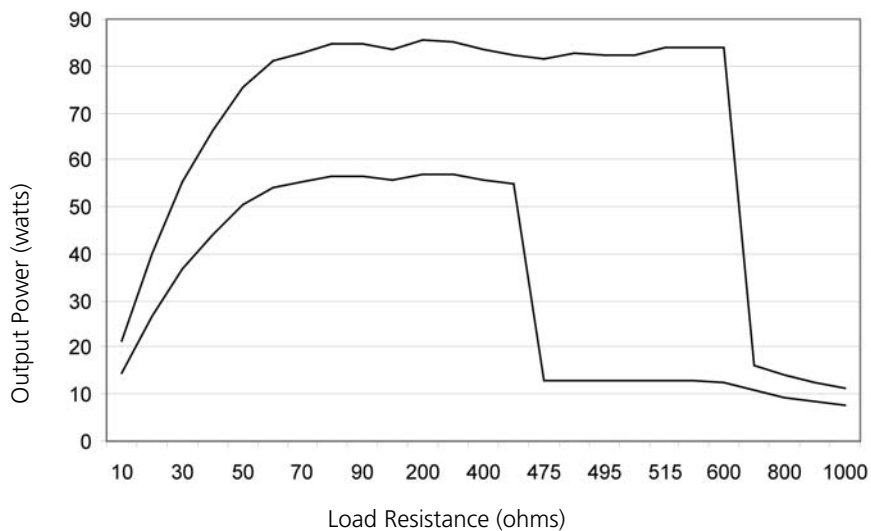

**Note:** In the Bipolar Standard mode only, the power curve will reflect both High and Low output values between the impedance range of 475-600 ohms. This is based on the sensed impedance value the generator calculates, and the tolerances of the sensing circuits. This is a function of the generator, as the software is designed to reduce (switch to Low output) the output power when the impedance exceeds a reference

475-600 ohms impedance) level. Clinically, above 475 ohms the tissue is almost completely desiccated. By dropping to lower output power levels, we allow the surgeon sufficient time to deactivate the output before tissue sticking occurs.

**Open circuit peak voltage vs. output power for Standard bipolar mode**

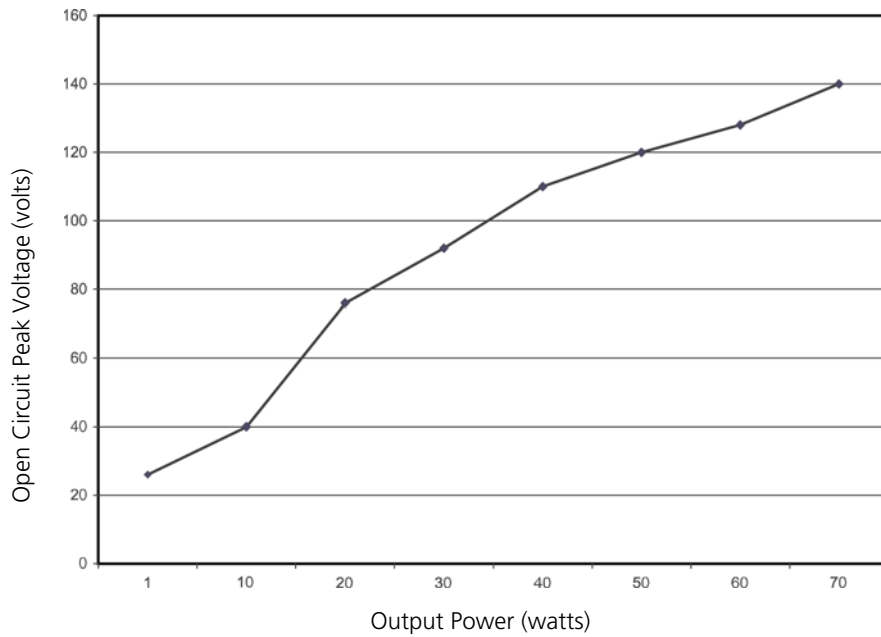

**Open circuit peak voltage vs. output power for Standard bipolar mode**

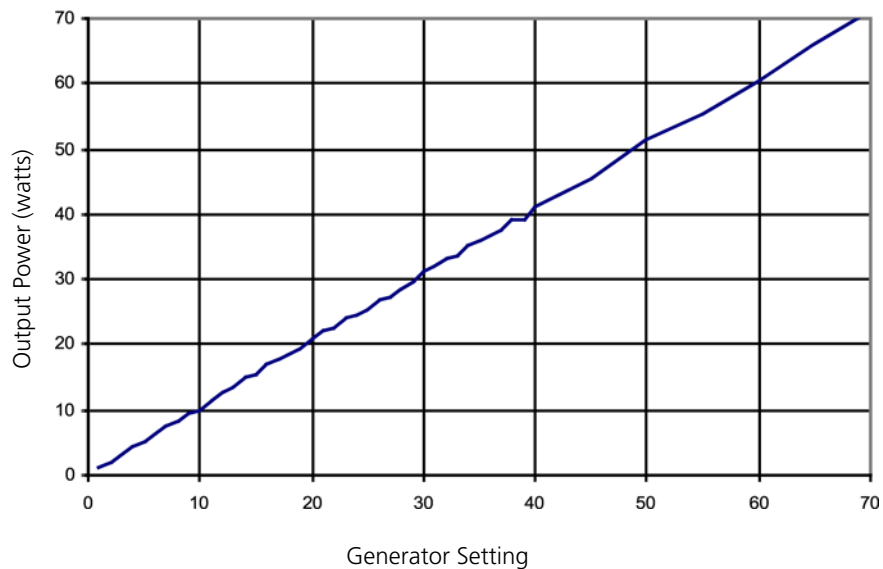

## Macrobipolar Mode

**Output power vs. impedance for Macrobipolar 35W mode**

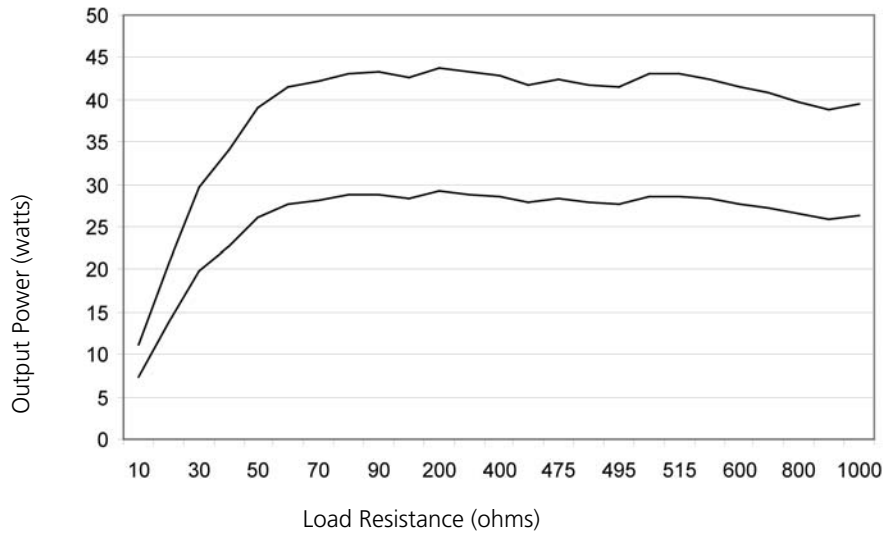

**Output power vs. impedance for Macrobipolar 70W mode**

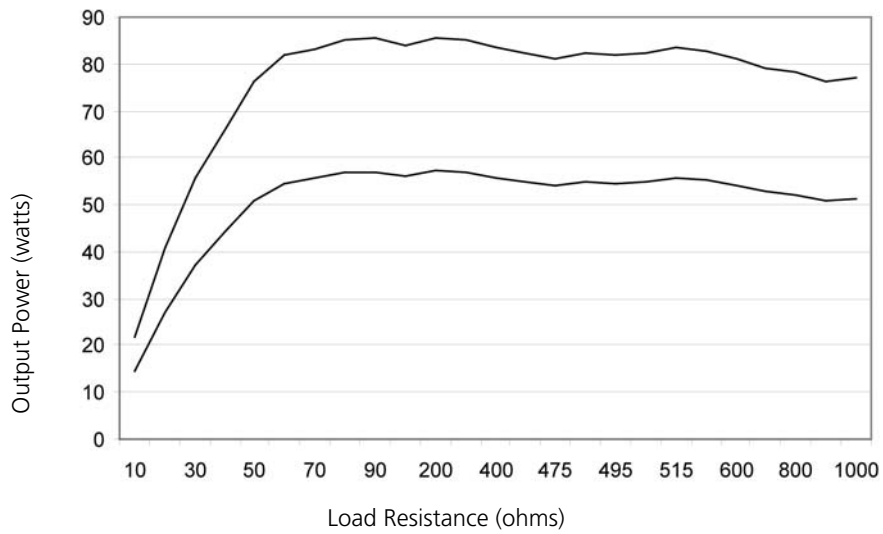

**Open circuit peak voltage vs. output power for Macrobipolar mode**

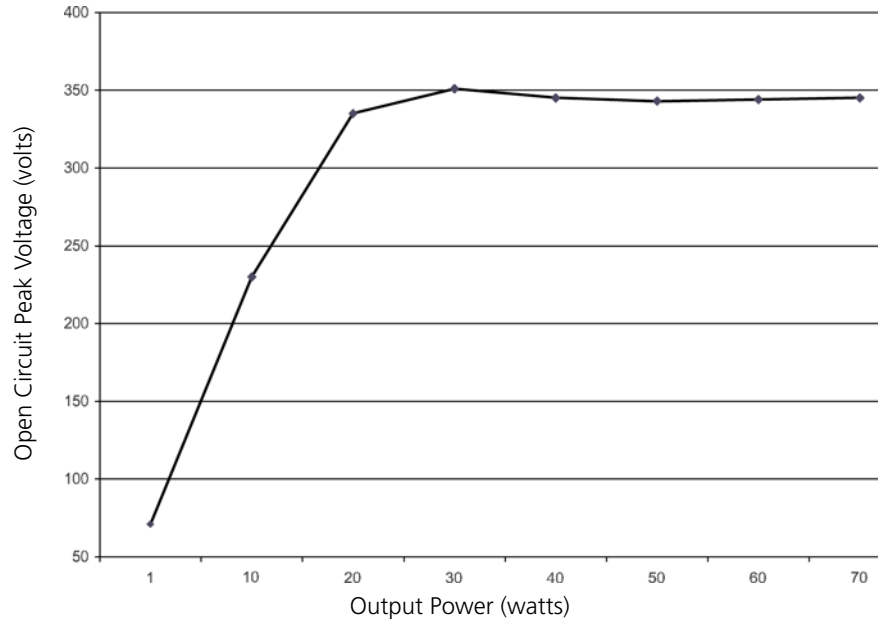

**Output power vs. generator settings Macrobipolar mode**

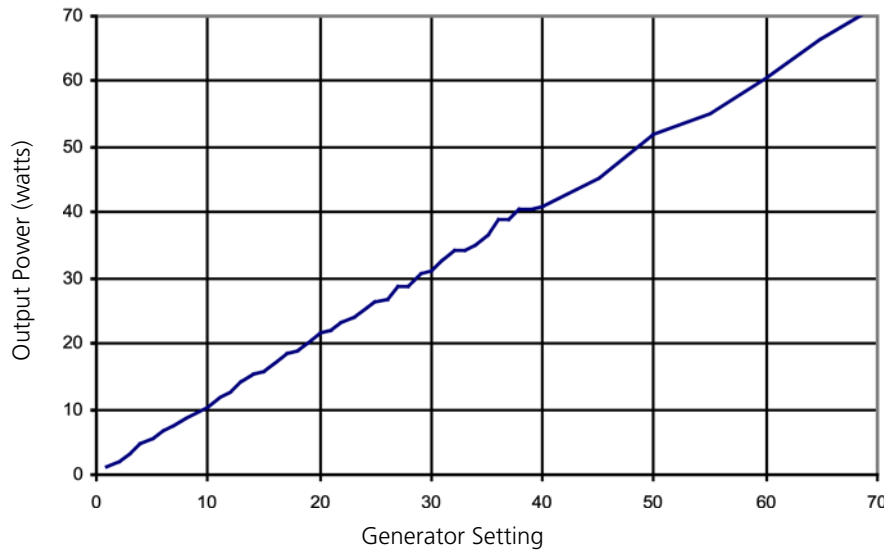

## Monopolar Cut Graphs

These measurements were taken using short (< 0.5 meter) leads.

### Low Cut Mode

**Output power vs. impedance for Low cut 150W mode**

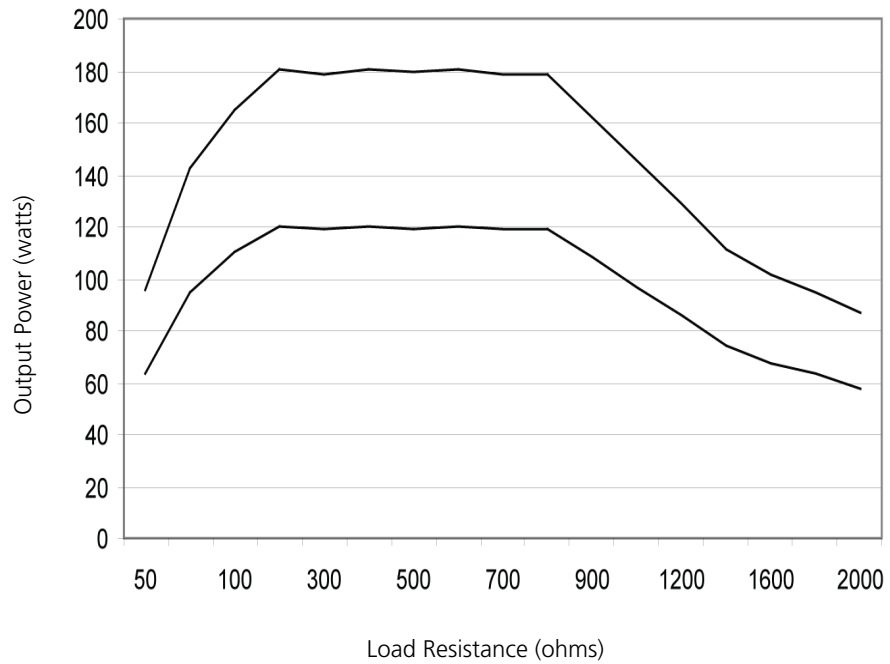

**Output power vs. impedance for Low cut 300W mode**

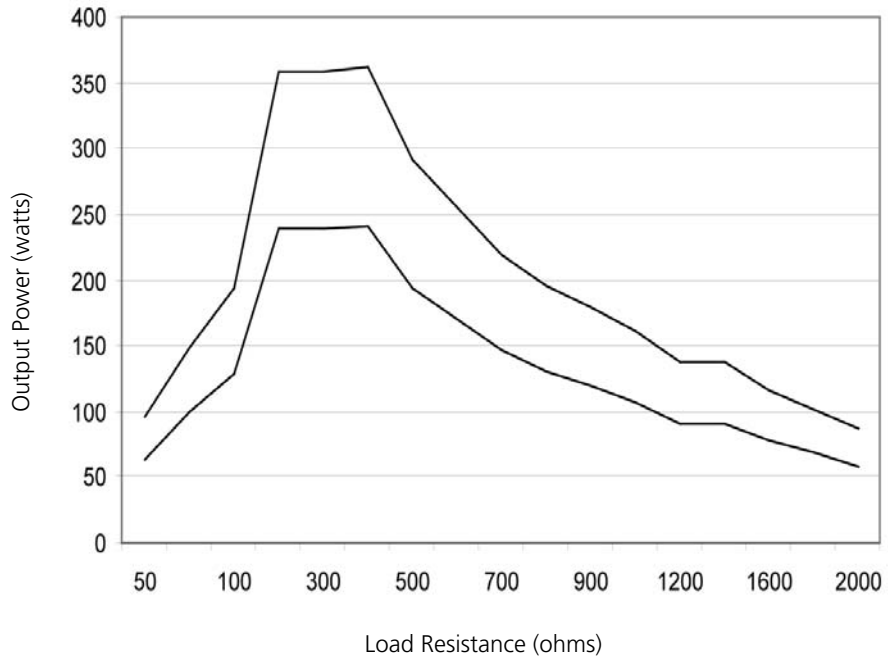

**Open circuit peak voltage vs. output power for Low cut mode**

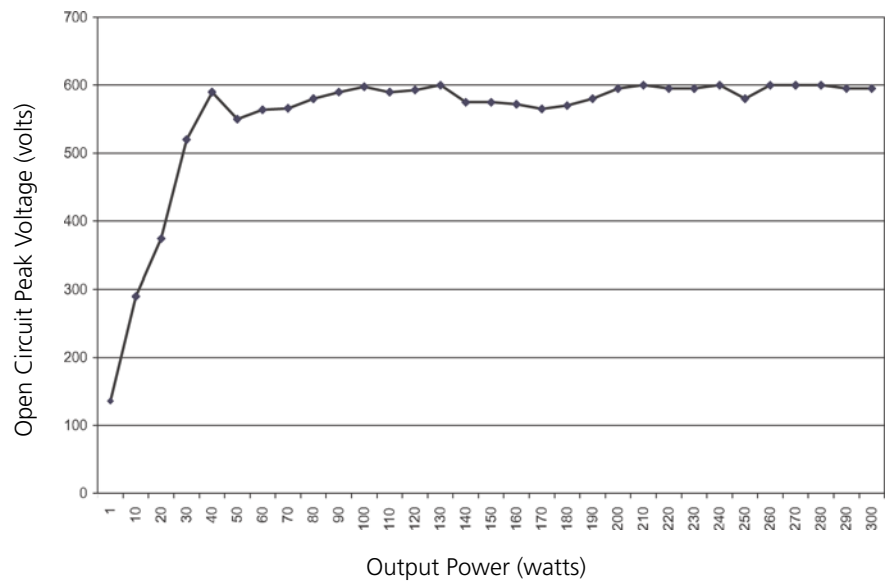

**Output power vs. generator settings Low cut mode**

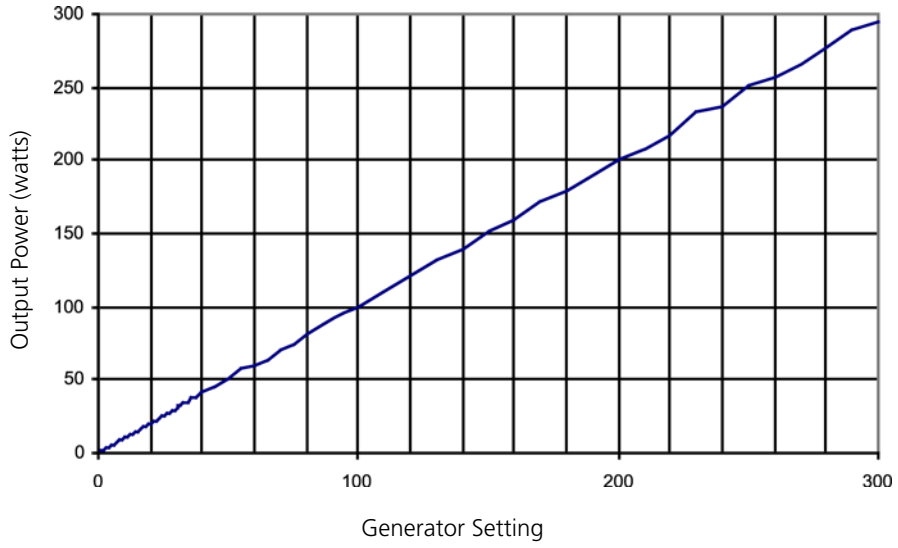

### Pure Cut Mode

**Output power vs. impedance for Pure cut 150W mode**

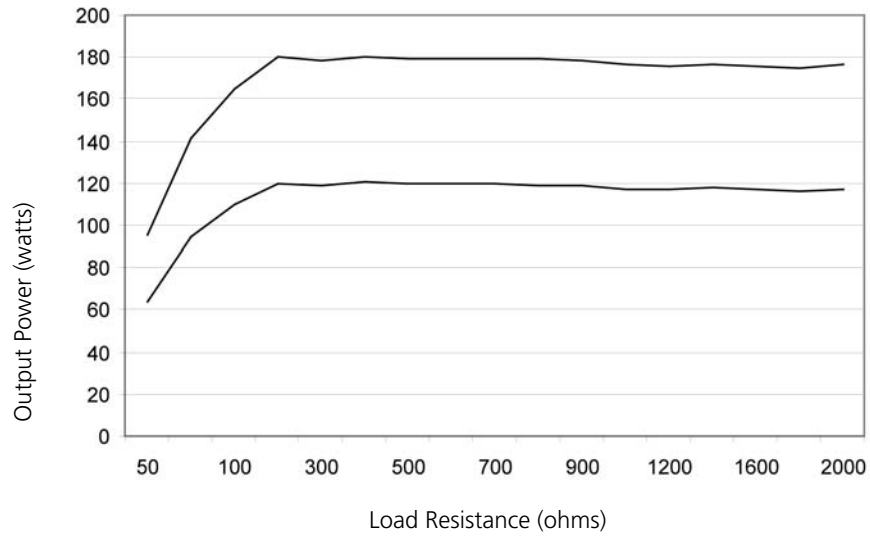

**Output power vs. impedance for Pure cut 300W mode**

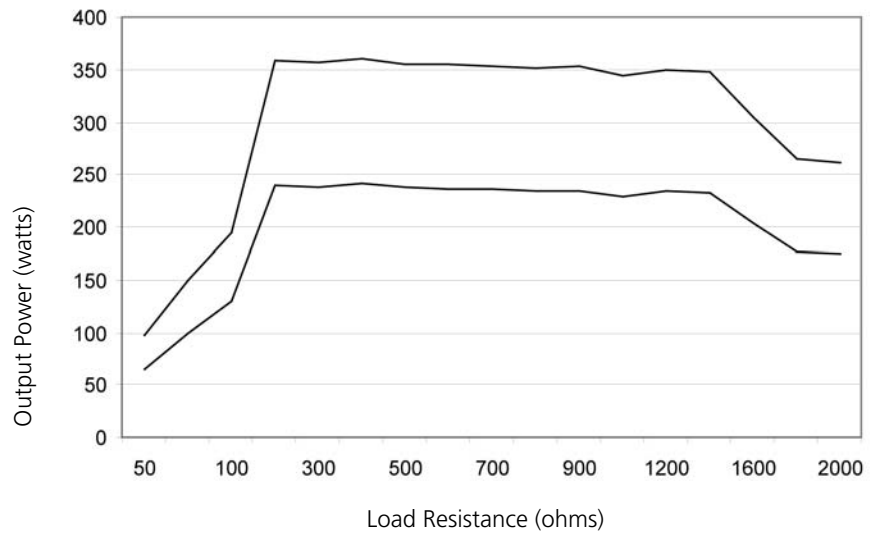

**Open circuit peak voltage vs. output power for Pure cut mode**

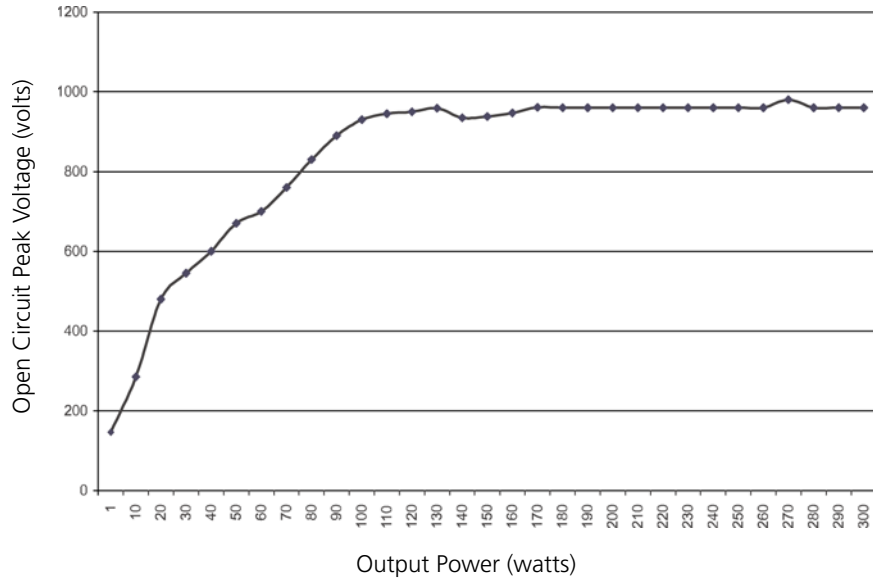

**Output power vs. generator settings Pure cut mode**

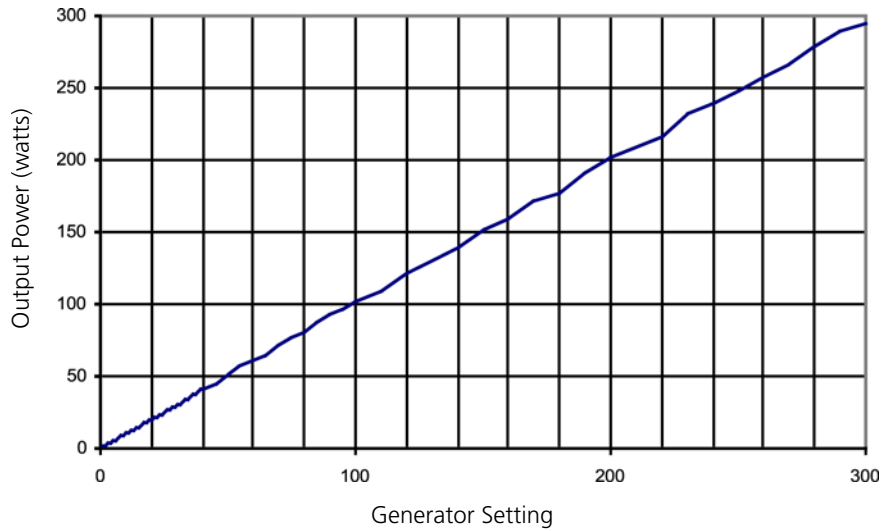

## Blend Cut Mode

Output power vs. impedance for Blend cut 100W mode

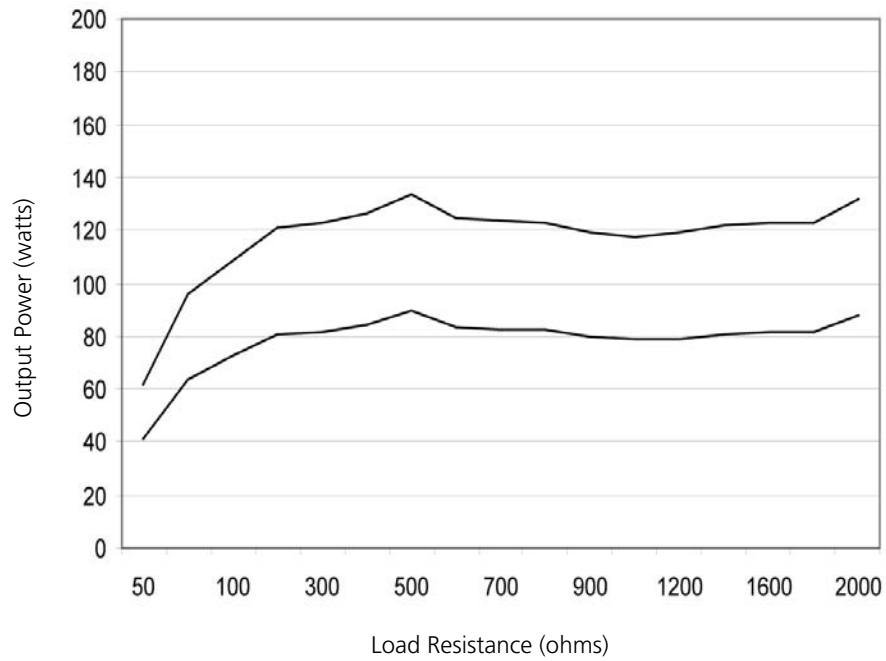

**Output power vs. impedance for Blend cut 200W mode**

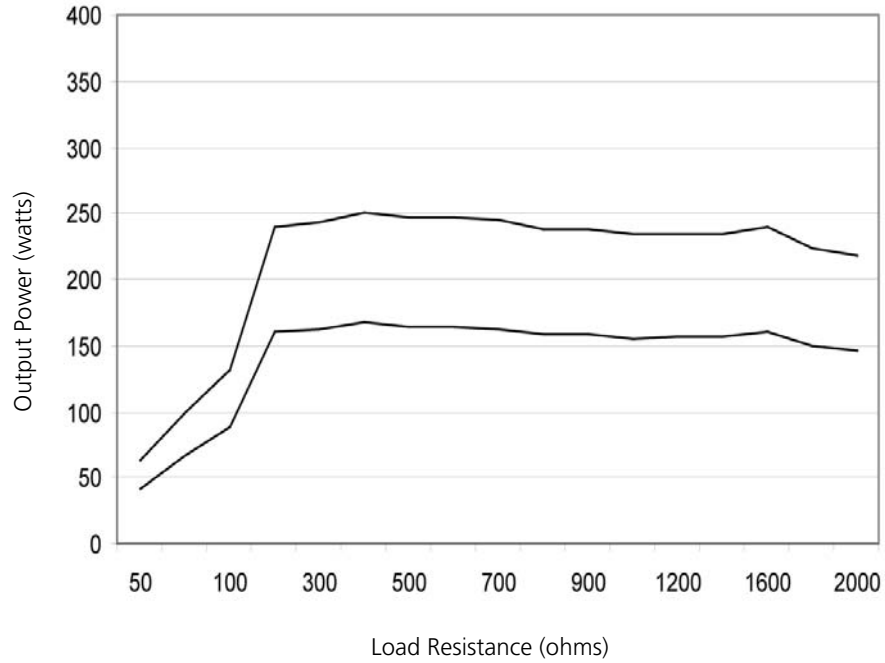

**Open circuit peak voltage vs. output power for Blend cut mode**

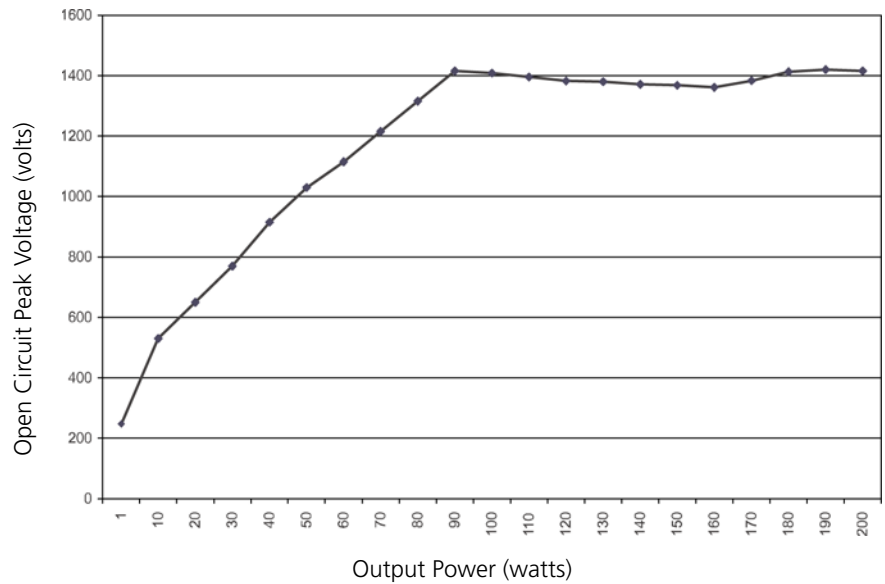

**Output power vs. generator settings Blend cut mode**

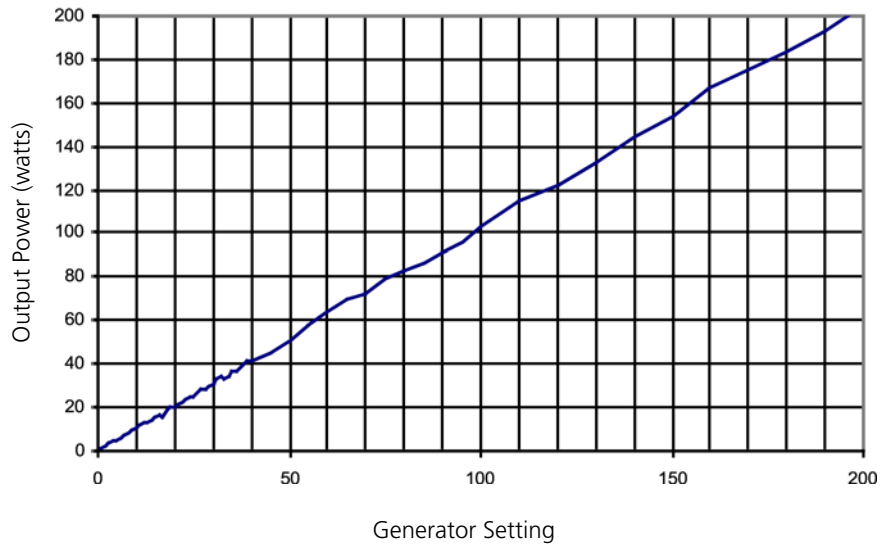

## Monopolar Coag Graphs

These measurements were taken using short (< 0.5 meter) leads.

### Desiccate Coag Mode

**Output power vs. impedance for Desiccate coag 60W mode**

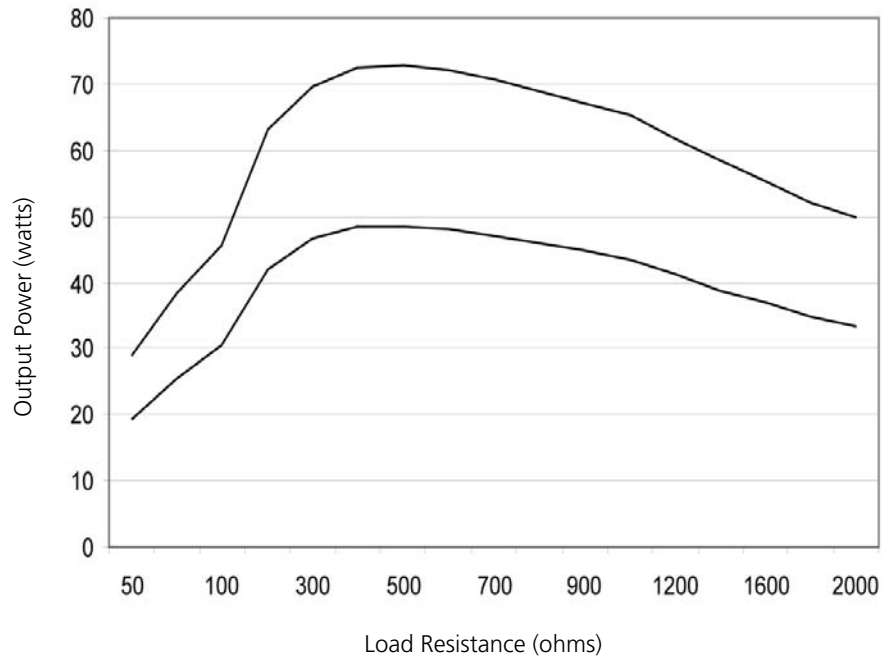

**Output power vs. impedance for Desiccate coag 120W mode**

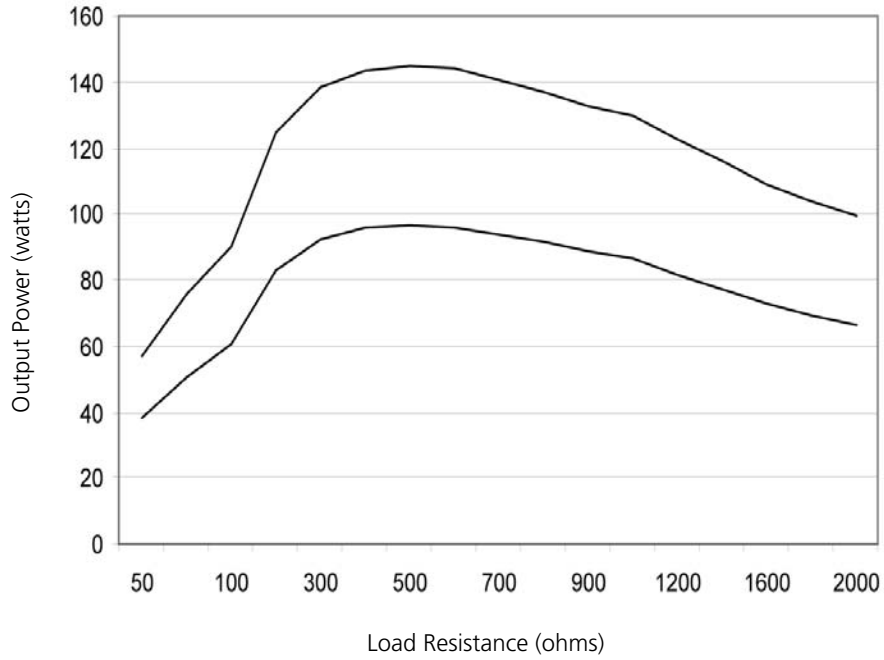

**Open circuit peak voltage vs. output power for Desiccate coag mode**

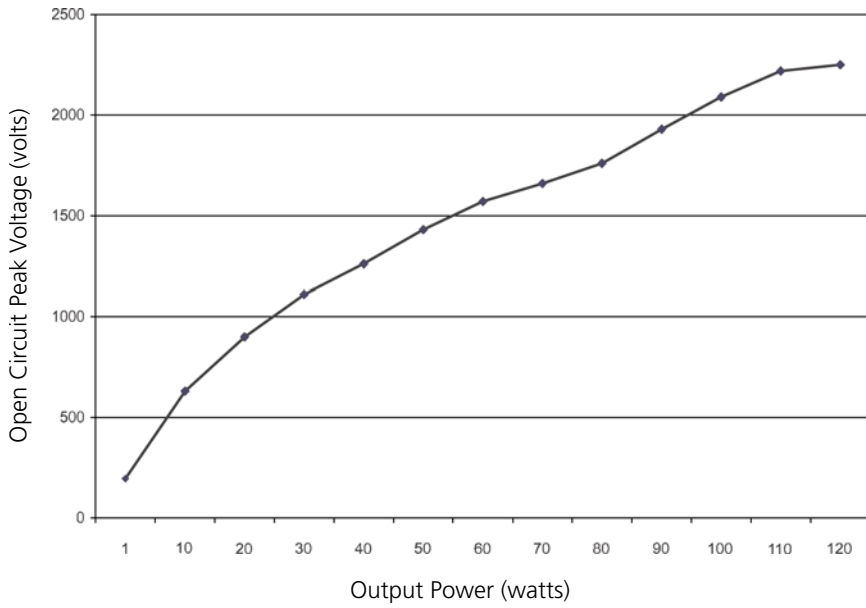

**Output power vs. generator settings Desiccate coag mode**

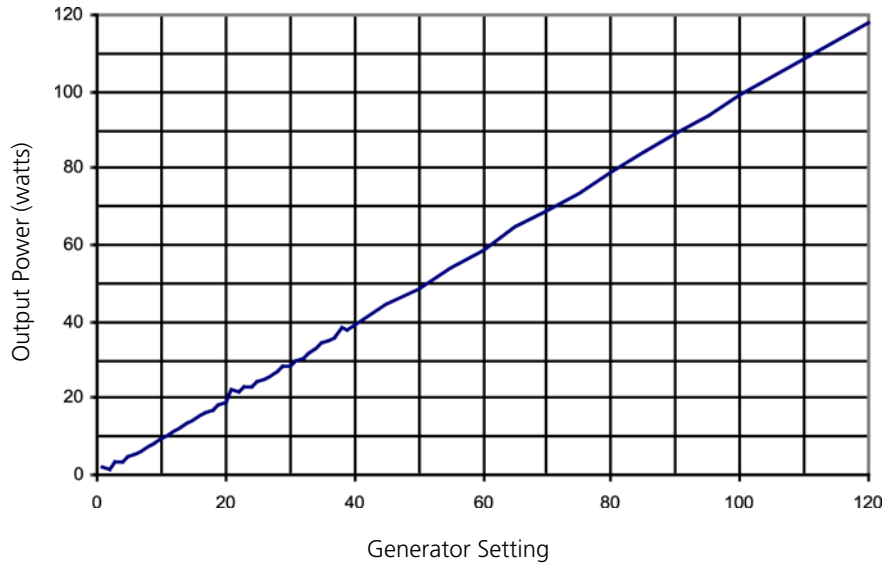

## Fulgurate Coag Mode

**Output power vs. impedance Fulgurate coag 60W mode**

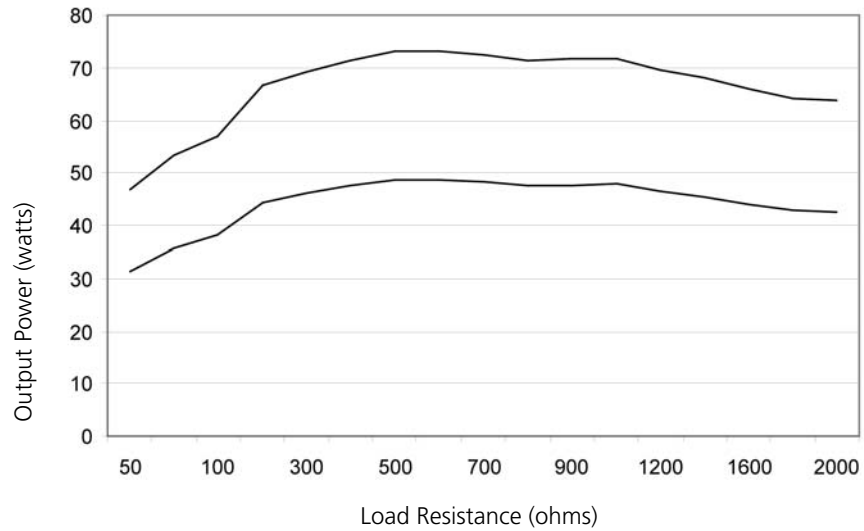

**Output power vs. impedance Fulgurate coag 120W mode**

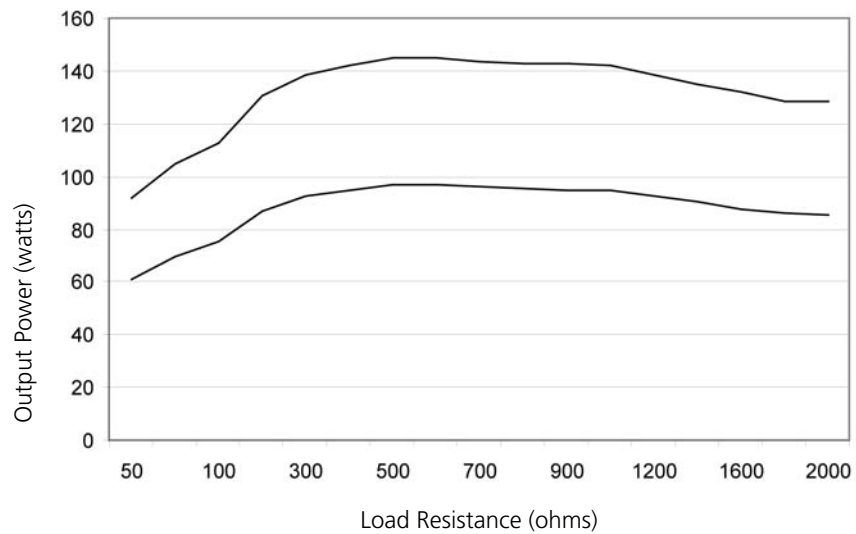

**Output power vs. peak voltage Fulgurate coag mode**

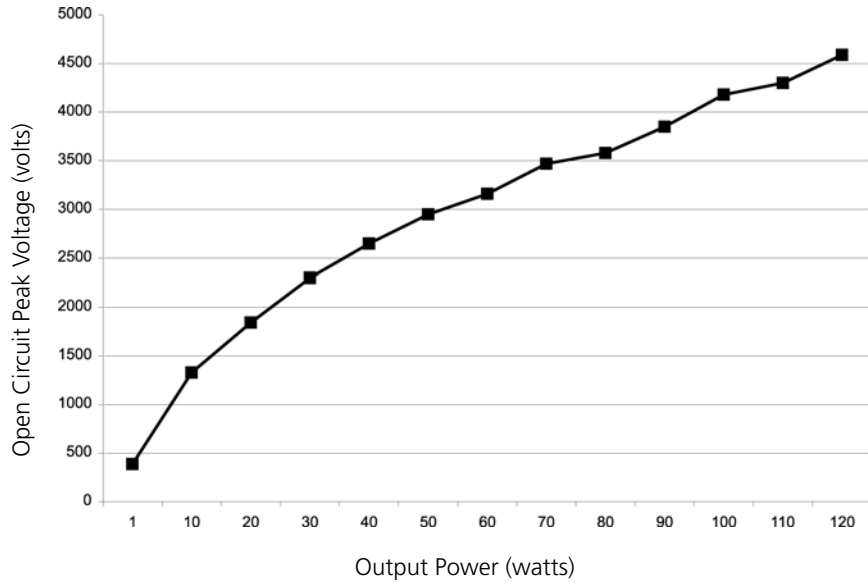

**Output power vs. generator settings Fulgurate coag mode**

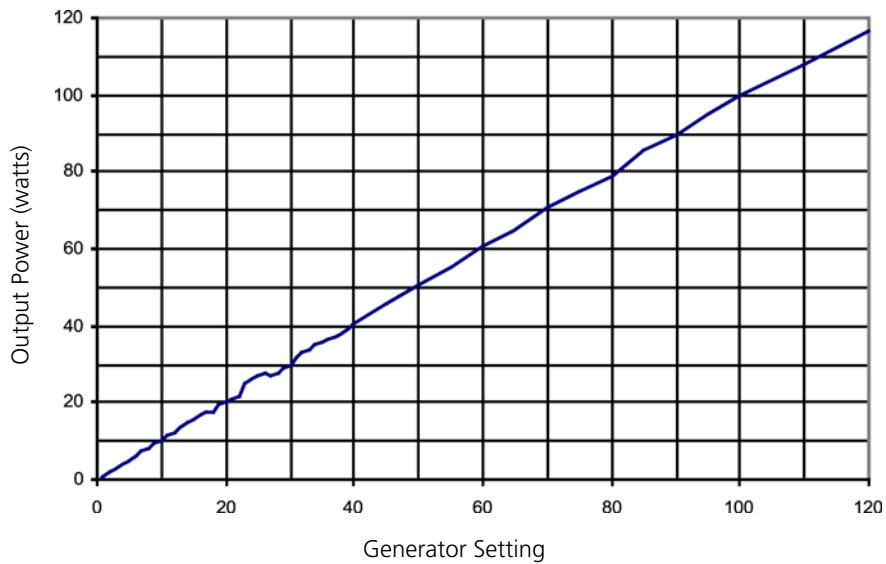

### LCF Fulgurate Coag Mode

**Output power vs. impedance LCF Fulgurate coag 60W mode**

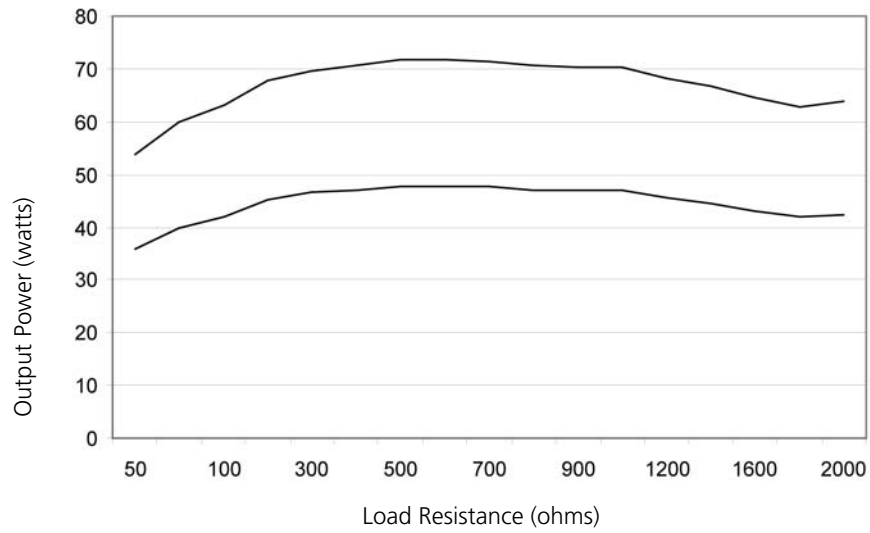

**Output power vs. impedance LCF Fulgurate coag 120W mode**

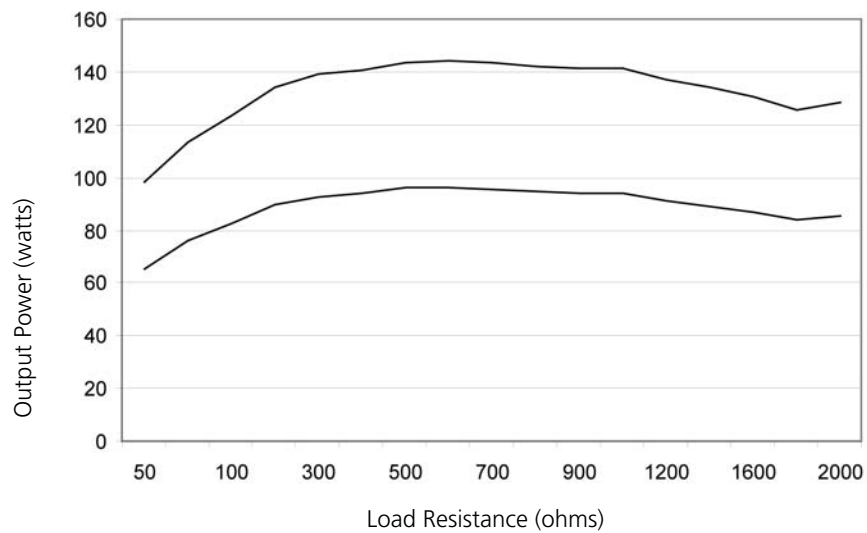

**Output power vs. peak voltage LCF Fulgurate mode**

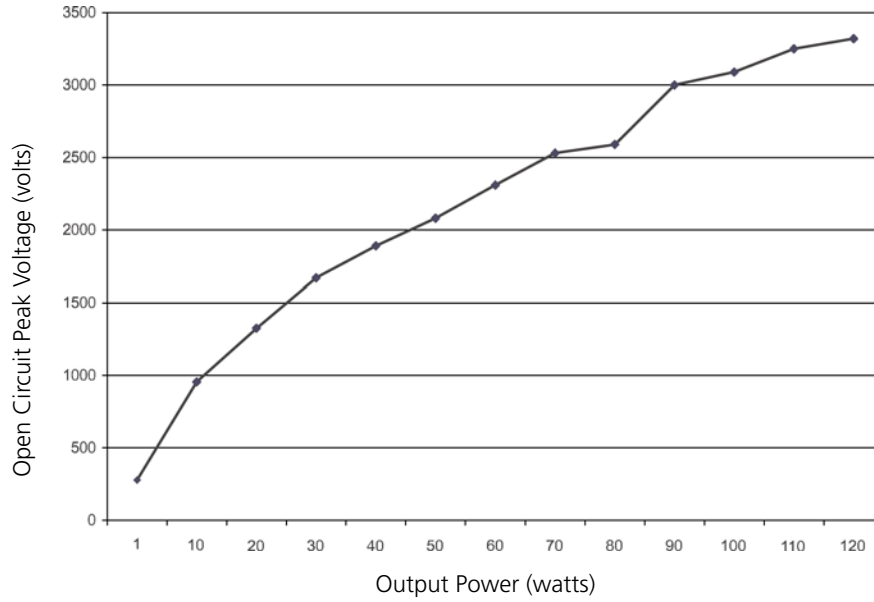

**Output power vs. generator settings LCF Fulgurate mode**

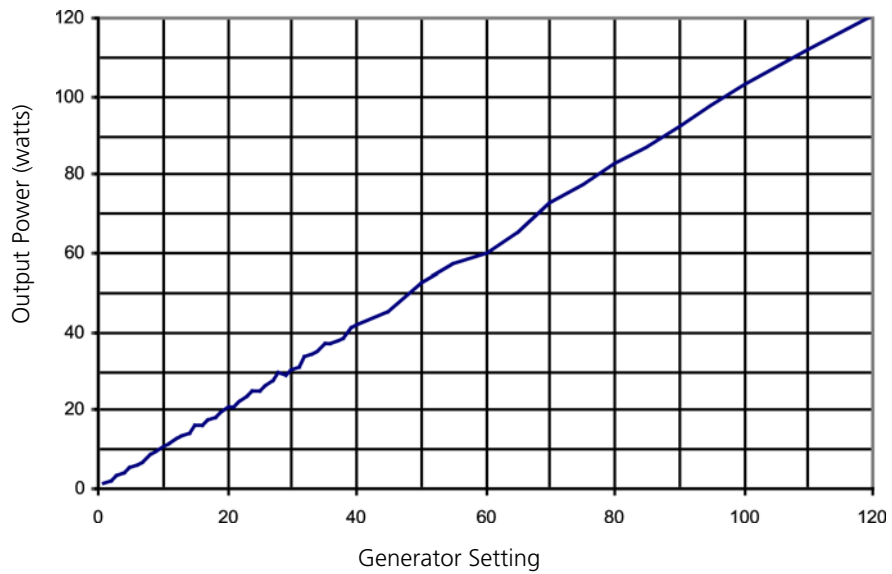

### Spray Coag Mode

Output power vs. impedance Spray coag 60W mode

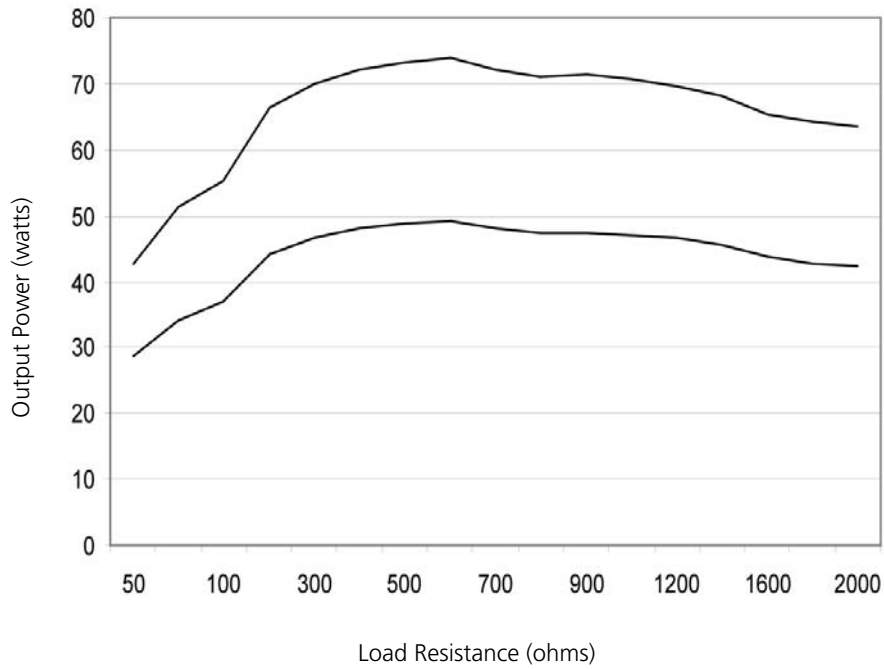

Output power vs. impedance Spray coag 120W mode

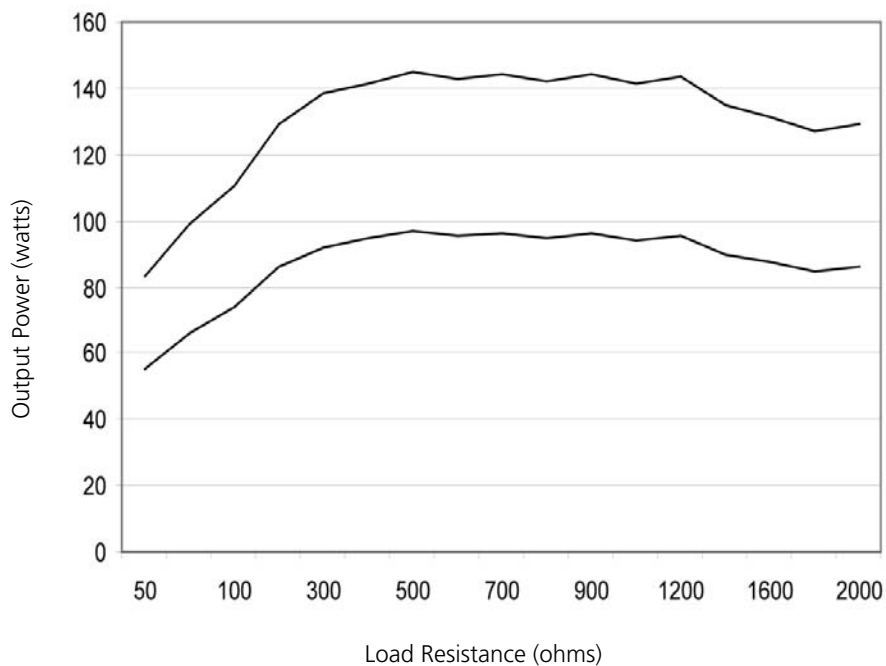

**Output power vs. peak voltage Spray coag mode**

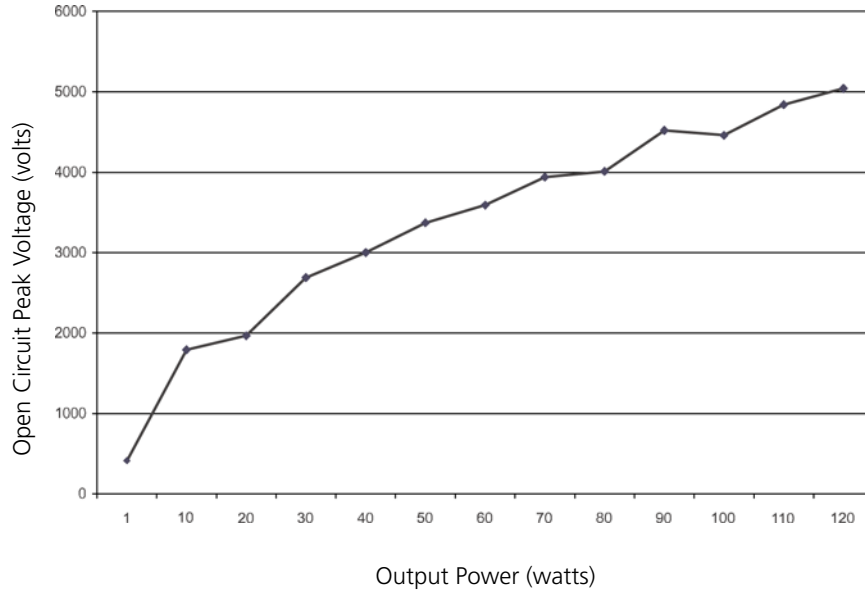

**Output power vs. generator settings Spray coag mode**

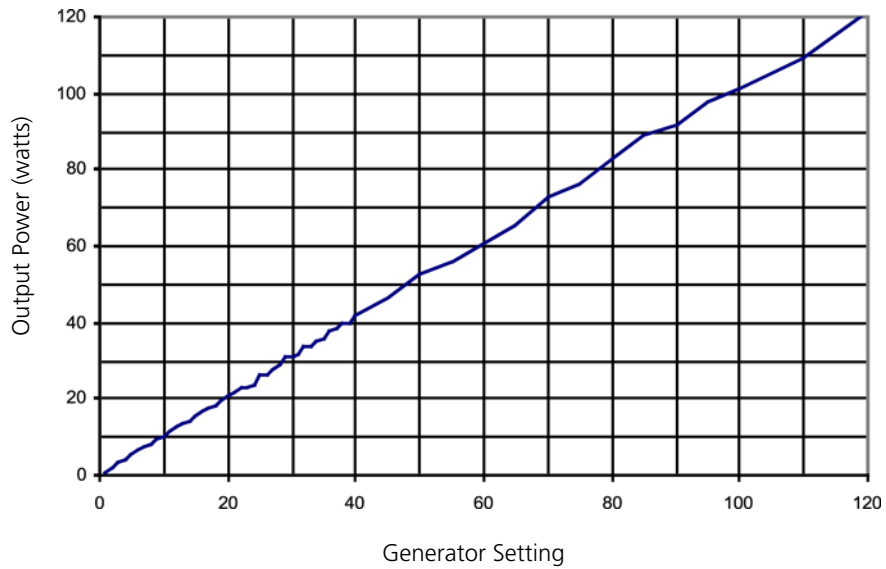

# Chapter 4

## Principles of Operation

This chapter provides detailed information about how the Force FX Electrosurgical Generator C functions and how the internal components interact.

The circuitry resides on four printed circuit boards: the Control board, the Display board, the Footswitch board, and the Power Supply/RF board.

This chapter includes the following information:

- A block diagram that illustrates how the generator functions
- A general description of how the generator works
- Detailed descriptions of the circuitry for each printed circuit board

# Block Diagram

A diagram of generator interconnections

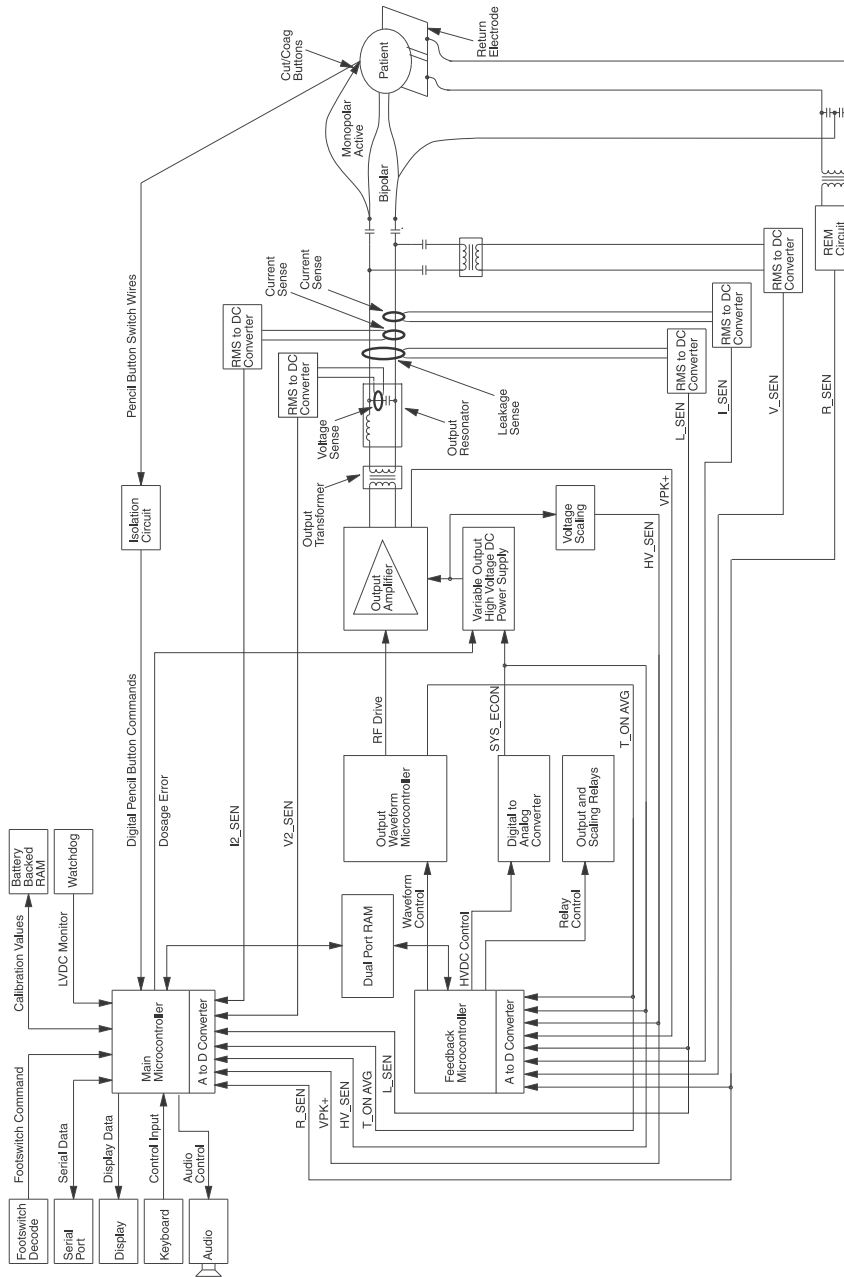

## Functional Overview

The Force FX Electrosurgical Generator C is specifically designed to cut and coagulate (desiccate and fulgurate) tissue during bipolar or monopolar electrosurgery.

During electrosurgery, radio frequency (RF) current flows from the generator to an active electrode, which delivers the current to the patient. The resistance to the current, provided by the patient's tissue and/or the air between the active electrode and the tissue, produces the heat that is necessary for the surgical effect. The RF current flows from the active electrode, through the patient's body tissue to the return electrode, which recovers the current and returns it to the generator.

## Instant Response Technology

The Force FX Electrosurgical Generator C automatically senses resistance and adjusts the output voltage to maintain a consistent tissue effect across different tissue density. This adjustment is based on the selected mode (bipolar or cut modes only), the power setting, and the level of tissue resistance. For details, refer to *Instant Response Algorithm* on page 4-12.

## Ultrasonic Electrosurgery

The Force FX Electrosurgical Generator C works in conjunction with the CUSA EXcel for procedures where ultrasonic electrosurgery is desirable. When you connect a CUSA handpiece with CEM nosecone to the generator for ultrasonic electrosurgery, the generator limits the monopolar output power automatically.

- The maximum power setting for monopolar cut is 100 W.
- The maximum power setting for monopolar coag is 70 W.

When you activate the handpiece for cut or coag output, the Low cut mode or the Desiccate coag mode is in effect automatically. The remaining cut modes and coag modes are not available.

For more information, refer to *CEM Mechanism Switch* on page 4-13 and *CEM Switch Circuit* on page 4-15.

## Simultaneous Coag

When you simultaneously activate two monopolar instruments for coag output, each receives a percentage of the coag power setting set for the selected mode. The amount of power each instrument receives depends on the tissue resistance sensed by the generator at each surgical site. Generally, the site with lower resistance receives proportionately more power. The combined total output power does not exceed the coag power setting.

You can also use a CUSA handpiece with a CEM nosecone for simultaneous coag when you connect a monopolar instrument to the Monopolar 2 Instrument receptacle. Only Desiccate coag is available; the maximum power setting is 70 W.

## REM Contact Quality Monitoring System

The Force FX Electrosurgical Generator C uses the REM Contact Quality Monitoring System to monitor the quality of electrical contact between the patient return electrode and the patient. The REM system is designed to eliminate the risk of burns at the return electrode site during monopolar electrosurgery.

When you connect a REM Polyhesive Patient Return Electrode to the Patient Return Electrode receptacle, you activate the REM system. When you activate monopolar output, the FX Electrosurgical Generator C connects the patient return electrode path. If you activate bipolar output while a return electrode is connected to the patient, the return electrode circuit is deactivated automatically to eliminate the possibility of current dispersal.

The REM system continuously measures resistance at the return electrode site and compares it to a standard range of safe resistance (between 5 and 135  $\Omega$ ), thus eliminating intermittent false alarms that could result from small changes in resistance. The REM system also adapts to individual patients by measuring the initial contact resistance (baseline resistance) between the patient and the patient return electrode. If the tissue impedance at the return electrode decreases during electrosurgery, the REM system resets the baseline resistance.

### REM Alarm Activation

The REM Alarm indicator flashes red, a tone sounds, and the generator stops producing output power when either of the following occurs:

- The measured resistance is below 5  $\Omega$  or above 135  $\Omega$ , the limits of the standard range of safe resistance.
- An increase in contact resistance is greater than 40% from the initial measurement (baseline resistance).

The REM Alarm indicator remains illuminated red until you correct the condition causing the alarm. Then, the indicator illuminates green and RF output is enabled.

### Electrodes Without the REM Safety Feature

When you use a patient return electrode that does not have the REM safety feature, the REM system does not monitor the patient contact area. The REM system can monitor only the pin-to-pin resistance at the connector and can detect broken wires or connectors in the return electrode cord.

The REM Alarm indicator does not illuminate green when you connect a non-REM patient return electrode. Instead, the indicator light is extinguished. If the generator detects a break in continuity between the electrode and the generator, the indicator illuminates red.

When resistance between the Patient Return Electrode receptacle pins exceeds 20  $\Omega$ , the REM Alarm indicator flashes red, a tone sounds twice, and RF output is disabled. The indicator remains illuminated red until you correct the condition causing the alarm. Then, the red indicator light is extinguished and RF output is enabled.

For additional information, refer to *REM Circuit* on page 4-26.

## Control Board

Refer to Chapter 9, *Service Parts*, for components and the Schematics Supplement for *Board Drawings and Schematics*.

The Control board contains the circuitry that controls the generator, including the indicators and switches on the Display board and the RF output stage on the Power Supply/RF board. Firmware on the Control board performs many diagnostic and initialization routines. Errors are reported as alarm numbers on the front panel.

The Control board interfaces with the Power Supply/RF board through a 96-pin card edge connector. It interfaces with the Display board through a 64-pin ribbon cable.

## Microcontrollers

Two microcontrollers on the Control board control the generator. These microprocessors communicate with each other through a shared RAM. The main microcontroller (U5) performs all system functions, except the time-critical real time feedback control of generator RF output.

The feedback microcontroller (U11), which is a separate, dedicated microcontroller, handles the time-critical real time feedback control of generator RF output. All system analog signals are available to these microcontrollers.

A third microcontroller (U9) functions as an application-specific integrated circuit, or ASIC. It generates the RF drive waveforms (T\_ON) for the RF output stage.

## Main Microcontroller

The main microcontroller (U5) is an 80C562 that incorporates an 8-input multiplexed 8-bit A/D converter. The main microcontroller is responsible for overall system control. It monitors all dosage error functions and safety circuits. It implements the user interface, including activation control. It is primarily responsible for these functions:

- Segment display drivers and LED update
- Power control buttons, mode buttons, and the activation interface
- Serial port interface
- Alarm handling
- REM
- Audio control
- Memory control and storage (system alarms with time stamps; calibration values)
- Real-time clock control and interface
- Internal self-tests
- Communicating with the feedback microcontroller

## Main Microcontroller Memory

The Main Controller section includes a Xilinx™\* Spartan XC6SLX9 FPGA (U16), along with a 4 Mbit SST39LF040 NOR Flash memory (U17) and Cypress™\* CY14B256LA Nonvolatile RAM (NVRAM) (U18). The Cypress NVRAM and the SST NOR Flash memory are interfaced to the controller through FPGA (U16).

The Cypress CY14B256LA-SP45XI is a fast static RAM, with a nonvolatile element in each memory cell. The access time is typically 45ns. The memory is organized as 32 K bytes of 8 bits each. Data transfers from the SRAM to the nonvolatile elements (the STORE operation) take place automatically at power-down. On power-up, data is restored to the SRAM (the RECALL operation) from the nonvolatile memory.

The NOR Flash memory acts as a code memory for the Main Controller, which does not have ROM memory.

## Battery-Backed RAM

A socket on the Control Board contains a 3.0 V lithium button cell battery (BT) that provides backup power to the DS12885Q + T&R Real-Time clock (U6). The device has several features, including 114 bytes of general purpose Nonvolatile RAM not dedicated to any special function within the device. This NV RAM is used by the processor program as battery-backed memory.

## Feedback Microcontroller

The feedback microcontroller (U11), like the main microcontroller, is an 80C562. It receives commands from the main microcontroller and, when the generator is activated, establishes the appropriate relay closures and activates RF output. It continually adjusts the output signal of the generator by controlling the high voltage DC power supply and the RF clock circuitry. It is primarily responsible for these functions:

- Scaling relay control and output relay control
- T\_ON ASIC waveform control
- Leakage control (coag)
- Constant voltage, current, and power feedback control
- ECON initialization
- Real-time information update (actual voltage, current, power, impedance, effect mode)
- Memory tests
- Communicating with the main microcontroller.

## Feedback Microcontroller Memory

The Feedback Controller section uses a Xilinx Spartan XC6SLX9 FPGA (U36) along with a 4 Mbit SST39LF040 NOR Flash memory (U43). However, unlike the Main Controller section, the Feedback section uses the Block Memory in the FPGA.

The NOR Flash memory acts as a code memory for the Feedback Controller, which does not have ROM memory. The Flash memory is interfaced to the controller through FPGA U36.

## Shared RAM

The 4K x 8 external shared static RAM is provided by an IDT 71342LA device (U50) DPRAM with semaphore flags. The shared RAM allows the main microcontroller (U5) and the feedback microcontroller (U11) to share common variables. It functions as a communications interface between the main and feedback microcontrollers. It also provides additional general purpose RAM to these microcontrollers.

## I/O Expansion

The FPGAs used in the Main and Feedback sections provide I/Os logic blocks and to implement the glue Logic. The FPGA is interfaced to the controller P80C562 on the parallel address and data bus.

The JTAG port is provided for programming the PROM (Configuration memory of FPGA) in the Main and Feedback sections. Both the PROMs (U23 and U45) and FPGAs (U16-E and U36-F) are connected in the JTAG chain.

## Keyboard Interface and Activation Inputs

The keyboard interface is a row and column matrix between three-bank selected output lines (BANK0, BANK1, and BANK2-labeled 413\_PA6) of the Dual Supply Bus Transceiver with Configurable Voltage Translation SN74LVC16T245 (U31). The voltage translator (U31) signals interface with the FPGA XC65LX9-3CSG225C (U16-D), which is used by the Main Microcontroller and eight Keyboard input lines (KBD\_D0-KBD\_D7).

The two Bus Transceiver SN74LVC2T45 (U32-U33) devices receive activation inputs from the IsoBloc™ decoding circuits on the Power Supply/RF Board. These two devices interface with the FPGA (U16-D).

## Power Supply Supervisor Circuit

The controller assembly requires three different voltage levels, +5V, +3.3V and +1.2V. These three power supply supervisory circuits use the Micrel™ MIC2776N-YM5 IC, to provide under-voltage monitoring and power-on reset generation.

The voltage present at the IN pin is compared to the internal 300mV reference voltage. A reset is triggered if and when  $V_{IN}$  falls below  $V_{REF}$ . The +5V Supervisory threshold is set to trigger a reset signal at +4.69V, the +3.3V Supervisory circuit will trigger a reset signal at +3.16V, and the +1.2V Supervisory circuit will initiate a reset signal at +1.15V.

## A/D and D/A Conversion

Each 80C562 microcontroller (U5 and U11) contains an 8-channel multiplexed 8-bit A/D converter. Resolution of voltage and current sense inputs is enhanced by incorporating gain scaling relays in the sense circuits on the Power Supply/RF board and prescaling based on the expected input voltage or current values.

An AD7226 quad D/A converter (U15) provides 4-channel 8-bit D/A capabilities for the feedback microcontroller to output 0 to 5 Vdc analog voltages.

## Waveform Generation (T\_ON ASIC)

A dedicated Atmel™ AT89C51 microcontroller (U9) generates the RF drive waveforms (T\_ON) for the RF output amplifier on the Power Supply/RF board. The microcontroller functions as an application-specific integrated circuit, or ASIC, performing an endless series of repetitive tasks while enabled.

The feedback microcontroller (U11) holds the T\_ON ASIC (U9) in a reset state until the feedback microcontroller detects a valid activation request. After validating the request, the feedback microcontroller releases the T\_ON ASIC from reset and communicates a 4-bit code that represents the generator mode to be activated. The acceptable activation codes are listed below:

- 0: Precise bipolar
  - 1: Standard and Macro bipolar
  - 2: Low and Pure Cut
  - 3: Blend cut
  - 7: Desiccate coag
  - 8: LCF Fulgurate coag
  - 9: Spray coag
  - 11: Spark-controlled Blend
  - 12: Fulgurate coag
- Codes 4, 5, 6, 10 and A–F are unused.

Each code generates a unique waveform pattern to be delivered to the RF output stage of the generator. The T\_ON ASIC reads and evaluates the code and, if the code value is acceptable, repetitively generates the appropriate waveform until the activation request ends. After the request ends, the feedback microcontroller places the T\_ON ASIC back into reset.

If the code received by the T\_ON ASIC is not valid, the internal program sets an error flag, deactivates all output signals, and remains in an error state until the system is reset.

## T\_ON Average Check

The T\_ON waveform generator output waveform is integrated in hardware and returned to the main microcontroller as an analog value called T\_ON average. The T\_ON average is different for each distinct output mode of the T\_ON waveform generator. The main microcontroller continually checks the T\_ON average for compliance with the calibrated value to ensure that the T\_ON waveform generator is operating properly.

The T\_ON average signal rests at 5 V when the generator is not activated and drops to the calibrated value when activation occurs. The main microcontroller checks to make sure the T\_ON average signal is within  $\pm 15$  counts of the calibrated value.

During wak control in the coag modes, the T\_ON average rises an indeterminate amount. Due to this unknown, the T\_ON average is allowed to rise to 253 counts, which guarantees the T\_ON waveform generator is still operating. The T\_ON average is still not allowed to drop below the lower limit of 15 counts mentioned above.

## Audio Alarm

The audio alarm circuit is located on the Footswitch board. The audio alarm is controlled by software and hardware.

- Software control is provided by the UP\_TONE\ (microcontroller tone) and LO\_TONE signals generated by the main microcontroller in response to activation inputs, alarms, and at power-up. These signals connect from the Control board to the Power Supply/RF board through the 96-pin connector and then from the Power Supply/RF board to the Footswitch board through the 16-pin footswitch ribbon connector.
- Hardware control is provided by the RF\_TONE\ signal generated in the RF output stage by RF sensing circuitry on the Power Supply/RF board.

## Serial Interface

The RS-232 serial port is a software-pollled interface to the main microcontroller (U5). It is used for diagnostics and calibration. Transmission and receipt of command strings do not stop real time processing, except as single characters are read from or written to the serial port. The serial port is configured to 9600 baud, 8 data bits, 1 stop bit, with no parity. This timing is derived from the main microcontroller oscillator frequency of 11.0592 MHz.

The Control board serial port signals connect to the Power Supply/RF board through the 96-pin connector. The signals are then connected to the 9-pin serial port connector on the Power Supply/RF board.

## Dosage Error Algorithm

### Dosage Error Algorithm for Closed-Loop Modes

The dosage error algorithm for the closed-loop modes (bipolar and cut) is based on a comparison between the actual power as calculated by the main microcontroller (U5) using the backup sensors and the maximum allowed power.

While the feedback microcontroller is operating the generator output, the main microcontroller calculates and checks the values to make sure the feedback microcontroller is operating the generator properly.

In a closed loop mode, there is a 500 ms delay before the dosage error algorithm monitors the RMS output of the generator. After the delay, the algorithm first checks to see that the voltage, current, and power calculated by the backup sensors are less than 125% of the value calculated by the primary sensors.

On passing this test, the feedback mode of the generator is taken into account.

- In current control mode, the current calculated by the backup sensors is not allowed to deviate from the current calculated by the primary sensors by more than 50% of the value calculated by the primary sensors.
- In voltage control mode, the voltage calculated by the backup sensors is not allowed to deviate from the voltage calculated by the primary sensors by more than 50% of the value calculated by the primary sensors.

During closed loop activation, the main microcontroller continually checks for broken backup sensors. The current and voltage sensor analog values are compared to the previous readings to ensure that the sensor values are not constant or falling while ECON is rising.

When the generator drops into spark control, the software makes allowances for the shift in frequency. The voltage sensor returns a value that is approximately 20–25% high, and the rms value calculated for the voltage sensor is reduced by 25%. The current sensor returns a value that is approximately 10–15% low, and the rms value calculated for the current sensor is increased by 12.5%.

The dosage error algorithm for the open loop modes (coag) is based on the ECON calculated for the mode. The main microcontroller calculates an ECON that represents 125% of the front panel power setting and verifies that SYS\_ECON and HV\_SEN do not exceed this value while the generator is activated.

These tests detect stuck or aberrant sensors and improperly delivered power in all modes. The dosage error firmware executes in less than one second.

## Instant Response Algorithm

This mode is a closed loop control algorithm implemented in microcontroller firmware. It is applied to the bipolar modes and the cut modes. It is not applied to the coag modes.

As tissue impedance increases from short circuit to open circuit, the algorithm implements first constant current, then constant power, and finally, constant voltage. The maximum output voltage is controlled to reduce capacitive coupling, reduce video interference, and eliminate sparking. At low impedances, constant current protects output circuitry. At high impedances, constant voltage control limits arcing and electromagnetic interference.

Constant current: output voltage is held at constant output current according to

$$I = (P/R)^{1/2}$$

where I is the output current, P is the power set by the user, and R is the constant current to constant power impedance switchpoint.

Constant power: the power set by the user is maintained.

Constant voltage: the output voltage is maintained according to

$$V = (P*R)^{1/2}$$

where V is the output voltage, P is the power set by the user, and R is the constant power to constant voltage impedance switchpoint.

## High Impedance Operation

The firmware algorithm clamps the output voltage to specific levels for high impedance conditions. The clamp level is a function of the mode that is activated. This helps prevent arcing and electromagnetic interference.

## Analog to Digital Saturation

Analog to digital saturation works in conjunction with RF leakage current limiting. If the analog to digital converter is saturated, the effect mode feedback loop reduces the output voltage to allow for an unsaturated operating condition. The feedback loop switches the control function to maintaining the analog to digital converter in the linear operating range.

## Front Panel

The front panel consists of an injection molded plastic bezel with a membrane keyboard, power switch, CEM mechanism switch, and REM connector with switch. These front panel components interface with the Display board and the Power Supply/RF board.

### Membrane Keyboard

The membrane keyboard is attached to the bezel with a high strength adhesive. It is not removable. The membrane contains 16 metal dome push-button switches. Six of these switches control the up and down sequencing of the power seven-segment LEDs (light-emitting diodes). One switch controls the previous settings Recall function and nine switches control each of the nine output modes of the generator.

The membrane also contains nine LEDs, one for each mode. A 25-pin flat ribbon cable connects the membrane keyboard switches and LEDs to the Display board.

### Power Switch

A double pole single throw switch snaps into the front of the bezel. This switch supplies the AC mains current to the generator.

### REM Connector/Switch

An internal REM connector and sense switch connects to the inside of the bezel with two screws. Two cables leave this assembly. One cable is the actual REM connector; the other cable is the output of the internal switch that senses the presence or absence of the center pin on the REM plug.

### CEM Mechanism Switch

A small plastic lever arm mechanism is attached to the inner wall of the front panel bezel on the Monopolar 1/CEM output jack. When you connect a CUSA handpiece with a CEM nosecone to the Monopolar 1/CEM Instrument receptacle, the arm actuates a small switch that connects to the Display board with a 4-pin connector.

## Display Board

Refer to Chapter 9, *Service Parts*, for components and the *Schematics Supplement* for board drawings and schematics.

The Display board is located in the front panel assembly. It contains RF indicator lamps, seven-segment LED power setting displays, REM alarm LEDs, and a CEM indicator LED. The Display board switch circuitry includes the LED and lamp driver circuitry, power selection switches, mode selection switches, the REM switch circuit, and the CEM switch circuit.

### RF Indicator Lamps

The RF indicator lamps illuminate during RF activation to visually indicate the presence of RF power. Each of the three indicator bars (Bipolar, Cut, and Coag) on the front panel is illuminated by four incandescent bulbs (LP1–LP12).

- LP1–LP4 illuminate the blue Bipolar bar, indicating bipolar activation.
- LP5–LP8 illuminate the yellow Cut bar, indicating cut activation.
- LP9–LP12 illuminate the blue Coag bar, indicating coag activation.

The RF indicator lamps are controlled by the BIP\_LMP, CUT\_LMP, and COAG\_LMP signals. These signals originate from the I/O pins of main FPGA (U16) on the Control board.

Buffers in U1 turn the RF indicator lamps on and off. Resistors R1–R12 set the amount of current flowing through the lamps when they are turned on. The value of these resistors varies for each indicator bar, depending on the color of the bar, to make the different colors of the bars illuminate with equal intensities.

### REM Indicators

The REM indicator consists of two bicolor LED arrays incorporating one red and four green LEDs per array. The LEDs are controlled by the REM\_RED and REM\_GREEN signals originating from port A of the Main Controller section (FPGA U16, NOR Flash U17 and SRAM U18) on the Control Board. The signals are buffered on the Display Board by driver U1. Both the red and green LEDs are current limited by 100Ω resistors (R13, R14, R15, and R16).

### LED and Seven-Segment Display Drivers

This circuit contains three display drivers for the LEDs and the seven-segment displays. The LEDs indicate modes of operation, and the REM condition. The seven-segment displays indicate bipolar, cut, and coag power settings.

Each display driver (U6, U10, and U14) can drive up to eight banks of eight LEDs by multiplexing the time that each bank is turned on. The banks can be wired together to increase the time that a group of LEDs is on, effectively increasing the brightness of that group.

U10 drives the discrete LEDs and the CEM LED. These include green indicators for the bipolar modes (Precise, Standard, and Macro), the cut modes (Low, Pure, and Blend), and the coag modes (Desiccate, Fulgurate, and Spray). The anode of the mode selection LEDs are tied to driver U10. By using pairs of the driver digit lines, the duty ratio for these LEDs is effectively 1/4.

U6 drives the seven-segment displays that indicate power settings. U4 and U5 indicate the bipolar power setting, U7–U9 indicate the cut power setting, and U11–U13 indicate the coag power setting. The anodes of these displays are each tied to only one digit line of the driver. The effective duty cycle is 1/8 for each seven-segment display.

Some filtering components are associated with U6, U10, and U14. Bypass capacitors C3, C4, C7, C8, C9, and C10 are connected between + 5V and DGND. C3, C4, and C10 have a relatively small capacitance value of 0.1  $\mu\text{F}$  to filter higher frequency noise. C7, C8, and C9 have a relatively large capacitance value of 47  $\mu\text{F}$  to supply the large spikes of current for the LEDs generated by the multiplexing action of the drivers, which typically occurs at 250 Hz.

Resistor array R18 reduces the input impedance of the display driver inputs as seen by the main microcontroller on the Control board. This rounds off the edges of these digital signals, reducing high frequency emissions. The lowered impedance also reduces the susceptibility of the circuit to noise from other circuits.

## CEM Switch Circuit

When you plug a CUSA handpiece with a CEM nosecone into the Monopolar 1/CEM Instrument receptacle, the small nonconductive pin in the plug pushes a spring-loaded plastic lever arm mounted inside the front panel. This lever arm activates a small switch that plugs into the Display board. The switch signal tells the microcontroller to limit the power.

## Mode Selection and Power Control Switches

The mode selection and power control switches are arranged in a matrix. The main microcontroller selects a bank of switches to read by asserting a bank select signal (BANK0, BANK1, and BANK2-labeled 413\_PA6) through port A of the Dual Supply Bus Transceiver with Configurable Voltage Translation SN74LVC16T245 (U31) and the FPGA XC65LX9-3CSG225C (U16-D) on the Control Board. These signals are buffered by FETs Q1, Q2, and Q3 respectively and become the switch drive signals COM0, COM1, AND COM2.

- When COM0 is selected, the power control switches is read.
- When COM1 is selected, the Recall Switch and the Bipolar mode select switches are read.

- When COM2 is selected, the Cut and Coag mode select switches are read.

To read the switches, the main microcontroller asserts the desired BANK select line and reads the state of the keyboard switch return lines KBD\_D0 through KBD\_D7. These lines are read through port A of FPGA U16-D and Voltage Translator U20 on the Control Board.

## Footswitch Board

Refer to Chapter 9, *Service Parts*, for components and the *Schematics Supplement* for board drawings and schematics.

The Footswitch board is mounted inside the rear panel. It contains circuitry accepting and decoding footswitch keying inputs and an audio circuit for announcing generator keying and various alarm tones. The Footswitch board interfaces with the Power Supply/RF board.

## Footswitch Decode Circuit

Two monopolar footswitch connectors and a bipolar footswitch connector are mounted on the Footswitch board and extend through the rear panel. The monopolar footswitch connectors (J3 and J2) accept monopolar footswitches and provide footswitching capability for the Monopolar 1/CEM and Monopolar 2 Instrument receptacles located on the front panel. Use only a Valleylab monopolar footswitch with the Force FX Electrosurgical Generator C.

Use of an incompatible footswitch may cause unexpected output. The bipolar footswitch connector (J4) accepts a bipolar footswitch and provides footswitching capability for the Bipolar Instrument receptacle on the front panel. Capacitors C39–C46 provide filtering that blocks high frequency noise from exiting the generator on the footswitch cables.

As required by the IEC, the footswitch circuit is isolated from patient connected and ground referenced circuits and is able to withstand a potential of 500 V<sub>rms</sub> (50/60 Hz). To obtain this isolation, the footswitch connected circuitry is powered from an isolated power supply (U2). The isolated power supply, a MER1S1212SC, operates from the ground referenced +12 V power supply and supplies an isolated 12 V.

Resistors R18 and R19 form a voltage divider that yields a signal (V<sub>ref2</sub>) of approximately 6 V. This reference voltage is applied to the noninverting inputs of comparators U3A, U3B, U4A, U4B, and U5A.

The common terminal of each footswitch is connected to the +12 V isolated power source. Footswitch activation causes this voltage to be applied to a resistor divider. The values of the resistors comprising the input divider are selected to provide a switching threshold of approximately 750 Ω.

The divided voltage is then applied to the inverting input of one of the five comparators. When the voltage at the inverting input exceeds the voltage at the noninverting input, the open collector output of the comparator turns on, causing current to flow in the LED

of the corresponding optoisolator. This current generates an IR beam that causes the associated photo-transistor to conduct. The collectors of the transistors are connected to input pins of an I/O port on the microcontroller where they activate the desired mode of operation.

## Audio Circuit

The audio system consists of an audio oscillator, tone control signals, a volume control potentiometer, an audio amplifier, and a speaker. A reference voltage ( $V_{ref}$ ) is used throughout the audio circuit and is generated by dividing the +12 V power supply down to about 2 V by R9 and R8.

The audio circuit annunciates the presence of RF output and provides an auditory indication of alarm conditions. A potentiometer adjusts the volume of RF output activation tones. The speaker volume cannot be turned off entirely. The volume of the tone issued during alarm conditions is not adjustable.

The audio oscillator is enabled when UP\_TONE\ or RF\_TONE\ is pulled low. Diodes D1 and D2 provide a wired OR function for the two signals. Because UP\_TONE\ and RF\_TONE\ are +5 V (logic level) signals, resistors R4 and R6 divide the +12 V audio power supply down to about 4.85 V to prevent D1 and D2 from sourcing current into the Voltage Translator U22 pins, which interfaces with FPGA U16-B, on the Control board.

When either UP\_TONE\ or RF\_TONE\ is enabled low, the voltage at the noninverting input of U1B is pulled below the  $V_{ref}$  threshold present at U1B inverting input, the open collector output of U1B is turned on, grounding R31 and allowing U6A to oscillate.

U6A is a relaxation oscillator whose frequencies are determined by the RC time constants of R30, C35, and C18. This design allows the oscillator to produce two distinct frequencies that can be selected by the state of the LO\_TONE signal.

- When LO\_TONE is not asserted, R30 and C35 determine the frequency of operation of the oscillator (approximately 900 Hz).
- When LO\_TONE is asserted (+5 V), the voltage at the noninverting input of U1A exceeds the 2 V  $V_{ref}$  signal at the inverting input, turning on its output transistor. This effectively connects C18 in parallel with C35 to produce a higher RC time constant for the oscillator, which results in a lower audio frequency of approximately 700 Hz.

The ALARM signal selects the user-controlled audio volume or the fixed alarm level volume. U1C and U1D are configured in an exclusive OR arrangement in which the state of the output transistors of U1C or U1D is complementary. In other words, the output transistor of one of these two devices is always on, but both cannot be on simultaneously.

Under normal operating conditions, the ALARM signal is low, allowing the U1C output to float while the U1D output transistor is turned on. The output of U1D creates a voltage divider through R11, R12 (the volume control potentiometer), and R32 to attenuate the audio signal to levels acceptable for input to the audio amplifier.

R32 determines the maximum audio volume and R11 determines the minimum audio volume. R10 determines the audio alert volume level. R34 provides an alternate audio signal path in the event of an open volume control potentiometer.

When the ALARM signal is high, the U1C output transistor is turned on while the output of U1D floats. When the U1C output transistor is on, R10 is pulled to ground and creates a fixed voltage divider with R32 to produce the alarm volume level at the input to audio amplifier U7.

Meanwhile, the output of U1D is allowed to float, thus removing the variable resistor divider from the circuit. In this case, the volume control potentiometer becomes a small resistance in series with the high impedance input from the audio amplifier, negating the effect of the volume setting.

Audio amplifier U7 and speaker SP1 comprise the final stage in the audio system. The audio signal is AC coupled to the amplifier by C25 to eliminate the need for well-controlled input biasing. The voltage gain of U7 is set to about 20 by floating its gain select pins. Because the U1 output signal is internally biased to  $V_{cc}/2$ , it is necessary to AC couple the speaker through C27 to prevent the amplifier from DC biasing the speaker.

## Power Supply/RF Board

Refer to Chapter 9, *Service Parts*, for components and the *Schematics Supplement* for board drawing and schematics.

The Power Supply/RF board is the main board of the generator. It contains the high voltage power supply and the RF output stage. Circuitry on this board performs several other functions:

- Output voltage monitoring
- Output current monitoring
- Leakage current sensing (RF leakage sensing and reduction circuits)
- Spark control circuit
- REM impedance monitoring (REM circuit)
- Handswitch closure detection (IsoBloc™ circuit)
- RS-232 connector
- Expansion connector
- EKG contact closure connector
- Output high voltage relays
- Temperature monitoring and fan control

## Power Supply/RF Board Interfaces

The Power Supply/RF board interfaces to other boards and components as follows:

- AC input line filter
- Control board
- Footswitch board
- Heat sink components (RF damping resistor, RF MOSFET, and high voltage power supply MOSFETs)
- Single-wire attachment points for connecting the sense transformers
- Low voltage power supply (AC input and DC output)
- Low noise fan

A series of fuse clips connect the RF outputs and other front panel interfaces (i.e., REM and handswitching signals). The fuse clips mate to lugs located in the output portion of the front panel.

## High Voltage Power Supply

### Warning

Potentially lethal AC and DC voltages are present in the AC line circuitry, high voltage DC circuitry, and associated mounting and heat sink hardware described in this manual. They are not isolated from the AC line. Take appropriate precautions when testing and troubleshooting this area of the generator.

The high voltage power supply section contains the power entry circuitry, auto mains switching circuitry, AC/DC conversion circuitry, and a DC/DC switching regulator.

### Power Entry Circuit

The power entry circuit consists of an integral three wire power cord receptacle, fuse drawer, EMI filter, and a separate power switch. The power switch is mounted on the front panel. The receptacle/filter is mounted on the rear panel of the generator. AC line fuses are changeable from the rear of the generator.

### Auto Mains Switching Circuitry

The auto mains switching circuit detects the AC line voltage level and controls the triac (D1). This triac controls the topology of the AC/DC converter.

For 120 Vac operation, the triac is on, which connects the AC neutral to the center of the AC/DC converter capacitor bank (C3, C10, C11, and C22). In this configuration, the circuit acts as a doubler using the right hand half of the bridge rectifier (CR80).

For 240 Vac operation the triac is off and CR80 is used as a full wave rectifier.

The control IC (U1) functions as follows: The series circuit (CR1, R1, R2, and C9) provides power for U1. Pin 1 (Vss) is a shunt regulator that provides a -9 V (nominal) output.

The divider (R3 and R4) measures the input line voltage. Because the voltage at pin 8 varies with the line, it can sense the line voltage zero crossing as well as the peak voltage.

Pins 2 and 3 are inputs to an oscillator used for triac triggering timing. R7 and C1 set the oscillator frequency.

Pin 7 is tied to Vss, which places the circuit in the fail-safe mode. Thus, once the circuit enters full bridge mode, it remains in that mode until input power is recycled. A power dropout cannot cause the circuit to accidentally act as a doubler when the higher input voltage range is used.

## AC/DC Converter

The AC/DC converter uses CR80 as either a doubler or full wave rectifier, depending on the input voltage. In either case, an unregulated nominal 300 Vdc is provided to the DC/DC switching regulator. Thermistors R32 and R33 provide inrush current limiting, and fuse F4 provides protection against faults in the DC/DC switcher.

Capacitors C3, C10, C11, and C22 are an energy storage reservoir for the DC/DC switcher. C29 is a high frequency bypass filter. Bleeder resistors R5 and R6 discharge the capacitors when the AC line is disconnected or the power switch is turned off.

## DC/DC Switching Regulator

The DC/DC switching regulator is a buck derived, pulse width modulated (PWM) transformer. It is an isolated, fixed frequency, full bridge converter. The PWM IC (U5) is used in the voltage mode. The output of the regulator is adjustable from approximately zero (0) to 180 Vdc.

The full bridge consists of four power MOSFETs (Q1, Q3, Q4, and Q5) that operate at AC line potential. Transistors Q3 and Q5 are on while Q1 and Q4 are off, and the reverse. In this manner, power signals to the power transformer are bidirectional, or push-pull.

This allows full utilization of the transformer core magnetization capability. Regulation is achieved by modulating the time that each MOSFET pair is on. Capacitor C32 in series with the power transformer T3 primary prevents DC flux imbalance.

A snubber circuit (C27 and R31) absorbs leakage energy spikes. Another snubber circuit (C49 and R51) reduces spikes due to reverse recovery of the output bridge rectifier.

The gate driver circuitry for each MOSFET is transformer-coupled through T1 to provide AC line isolation. It consists of a dual MOSFET driver (U3) and various damping resistors. Resistors R12, R18, R21, and R26 minimize turn-off oscillations. Resistors R22 and R23 damp ringing due to parasitic inductances in T1. Blocking capacitors C24 and C25 prevent DC flux imbalance in T1.

**Note:** T1 consists of two transformers electrically and magnetically isolated from each other but assembled into the same package. T1A and T1B form one transformer; T1C

and T1D form the other.

The output of the power transformer is full wave rectified by a high voltage diode bridge (CR10, CR13, CR19, and CR23). L1, C33, and C35 filter the rectified power signal. The regulated DC output from this supply is the input to the RF stage of the generator.

The SYS\_ECON signal from the microcontroller controls the output voltage level. This 0 to 5 Vdc signal sets the reference for the PWM control loop.

An external op-amp (U7B) is used for gain and integration, because common mode voltage limitations in U5's internal op-amp preclude its use over the full range of 0 to 5 V. The internal op-amp is connected as a follower.

SYS\_ECON is compared to the feedback voltage from the output divider (R34, R35, and R49), and an error signal (ECON) is sent to the PWM microcontroller. In addition to the error signal, U7B and the associated R-C networks provide lead-lag loop compensation to increase the bandwidth of the regulator beyond that of the output L-C filter.

**Note:** U7A is used for random gain switching in the Spray mode and is configured for unity gain in all other modes.

The output of U5 is a pair of 180° out-of-phase signals that are pulse width modulated by comparing ECON with the internal oscillator ramp waveform. At the start of an oscillator cycle, an output is turned on. It turns off when the ramp voltage crosses the ECON level. The two output signals from U5 (pins 11 and 14) feed the MOSFET drivers (U3A and U3B).

R36 and C42 set the U5 oscillator frequency to approximately 170 kHz. C45 controls the ramp-up of the pulse width at power on for slow start control. Transformer T2 limits the power transformer primary current, protecting against faults in the DC/DC switcher power stage and faults in circuitry downstream of the switcher.

The output of T2 is rectified (CR3–CR6), filtered (R30 and C30), and fed to the current limit pin (pin 9 of U5). During an overcurrent condition the U5 current limit function resets the slow start circuit, resulting in the output cycling from on to off until the current falls.

Pin 9 of U5 is also used for remote shut down of the DC/DC switcher through U6A and CR8. The shut down signal comes from the main microcontroller on the Control board.

The resistor divider on the high voltage DC output formed by R52 and R53 is used for dosage error sensing.

## Low Voltage Power Supply

The low voltage power supply is rated for 40 W. It delivers a regulated +5 Vdc and  $\pm 12$  Vdc output. This power supply automatically adjusts for both input voltage ranges. It also has internal current limiting. The pinouts between the low voltage power supply and the Power Supply/RF board are listed below:

Low Voltage Supply J2-PIN	Voltage	PSRF Board BW14-PIN	Test Point
1 (ORG Lead)	+ 12 V	3	TP6
2 (RED Lead)	+ 5 V	1	TP8
3 (RED Lead)	+ 5 V	6	TP 8
4 (BLK Lead)	GROUND	4	TP9
5 (BLK Lead)	GROUND	5	TP9
6 (BLU Lead)	- 12 V	2	TP5

The low voltage power supply specifications are as follows:

Output Voltage	Output Current	Output Power*
+5 Vdc	4000 mA	20.0 W
-12 Vdc	400 mA	4.8 W
+12 Vdc	2000 mA	24.0 W

\*Total output power cannot exceed 40 W.

## RF Output Stage

### Warning

High frequency, high voltage signals that can cause severe burns are present in the RF output stage and in the associated mounting and heat sink hardware described in this manual. Take appropriate precautions when testing and troubleshooting this area of the generator.

The RF stage consists of a single MOSFET power switch with associated gate drive circuitry, an RF power transformer, tuning capacitors, an RF output L-C-C filter, output directing relays, and topology selecting relays. Also included in this section are the RF voltage and current sense circuits and a switched damping network for certain operational modes.

The MOSFET gets its gating signal from the T\_ON ASIC on the Control board. The T\_ON ASIC also provides the gating signal for the switched damping network.

When the topology selecting relays (K2 and K14) are unenergized, the RF stage is in the Fulgurate and Spray coag modes; when both are energized, the RF stage is in the cut and bipolar modes. For the Desiccate coag mode, K2 is unenergized and K14 is energized.

### Primary Sense Circuits

The primary voltage and current sense circuits provide feedback information to the feedback microcontroller in the bipolar and cut modes.

For voltage sensing, the two 10 k  $\Omega$  resistors (R148 and R149) in series with the primary of T13 work with the 100  $\Omega$  resistor across the secondary to divide the output voltage down.

Depending on the front panel power setting, one of the four relays (K3 to K6) is switched in to give optimum scaling. The four AD827 high speed op-amps, along with the associated resistors, capacitors, and diodes, form a precision full wave rectifier circuit.

U11B is a high input impedance follower to prevent the rectifier circuit from loading down the resistive divider. U11A is a follower that adds phase delay, which improves balance in the rectified waveform between positive and negative half cycles of the input signal.

The actual rectification is done with U8A and U8B. The rectified waveform is converted to DC by the R-C filter after the last op-amp, with full scale being 5 Vdc.

The current sense circuit, which uses current transformers T6 and T8, works the same as the voltage sense circuit. T6 senses bipolar current and T8 senses monopolar current. Relay K7 selects the appropriate current. Note that the current scaling relays (K8 to K11) switch at different power settings than the voltage scaling relays.

### Redundant Sense Circuits

Redundant voltage and current sense circuits provide dosage error monitoring.

T16 monitors the current through the output capacitors (C150, C152, and C158). This current is proportional to the output voltage of the generator. A full bridge rectifier is formed by CR25–CR28. The rectifier output is filtered by R118 and C96. Op-amp U18 buffers the DC signal. R119 and C97 provide additional filtering.

T17 and the associated circuitry operate the same as the redundant voltage sense circuit. The output is a signal proportional to the output current of the generator.

## Cut Modes

In the cut modes, K2 is set so that diode CR2 is in parallel with the MOSFET body drain diode, C34 and C41 are across the MOSFET, and the transformer primary consists of windings 1-2 and 3-4 in series. K14 is closed so the series capacitor bank (C150–C152, C158, and C159) is across the output.

In the Low and Pure cut modes, the T\_ON\ signal is a continuous pulse train with a pulse width of 846 ns and a frequency of 390 kHz. In this case, essentially two resonant circuits operate in tandem.

The output L-C filter is tuned just slightly higher than the RF switching frequency, achieving a high degree of filtering. The output is very sinusoidal over the full range of load impedances.

Capacitors C34 and C41 are tuned with the RF transformer primary so that the flyback voltage appearing across the MOSFET at turn off is a half sine pulse and returns to zero volts before the next cycle begins. The T\_ON\ pulse width is chosen to support this tuning. This zero voltage switching improves the efficiency of the RF stage and is effective over a wide range of load impedances.

The circuit topology of the Blend cut mode is the same as the Pure cut mode. In Blend mode, however, the T\_ON\ signal is an interrupted pulse train with a 50% duty cycle and a pulse train repetition rate of 27 kHz.

For a given power setting, Blend gives a higher peak current, providing better hemostasis than Pure or Low. To minimize ringing at the beginning of the off period of the Blend waveform envelope, the damping resistor is switched on just before switching ends and stays on for part of the off period.

## Bipolar Modes

The circuit topology for the bipolar modes is essentially the same as the cut modes, except the output voltage is tapped off C152 and the switching frequency is 470 kHz. These differences allow for the higher currents and lower voltages required in bipolar surgery while still maintaining the advantages of zero voltage switching in the MOSFET. The T\_ON\ signal is a continuous pulse train with a 423 ns pulse width.

## Coag Modes

In the Fulgurate and Spray coag modes, K2 is set so that diode CR2 blocks reverse current in the power MOSFET, C40 as well as C34 and C41 are across the MOSFET, and the transformer primary consists of winding 1-2 only. K14 is open, keeping the series capacitor bank (C150–C152, C158, and C159) out of the circuit.

In the LCF Fulgurate coag mode, the T\_ON\ signal is a continuous pulse train with a pulse width of 1.69  $\mu$ s and a repetition frequency of 57 kHz. When the MOSFET turns on, some energy is delivered to the output and some is stored in the T4 core. When the MOSFET is turned off, the energy stored in the core rings out with a frequency of 591 kHz.

The frequency is set by C34, C40, C41, and the inductance of winding 1-2 of T4. CR2 blocks reverse current in the body drain diode of the MOSFET so that the power waveform can ring negative. This allows high peak voltages to be achieved at the output.

In most cases, all the energy stored in the transformer core during one switching cycle is delivered to the load before the next cycle begins. The Fulgurate mode works the same as the LCF Fulgurate mode, except the T\_ON\ signal is a continuous pulse train with a pulse width of 1.69  $\mu$ s and a repetition frequency of 30 kHz.

The Spray mode works essentially the same as the Fulgurate mode, except the T\_ON\ pulse frequency is randomized over the range of 21.6 kHz to 35.23 kHz. In addition, amplifier U7A randomly varies the output amplitude by 10%. The ECON-GAIN signal from the Control board changes the gain of U7A between 1 and 1.1.

To minimize ringing on the output voltage waveform at light loads, transistor Q7 switches in the 50 watt, 150  $\Omega$  heat sink mounted resistor in series with the transformer primary for part of the RF switching cycle.

In the Desiccate coag mode, K2 is closed and K14 is open. The T\_ON\ signal is a continuous pulse train with a pulse width of 2  $\mu$ s and a frequency of 39 kHz. The output resonates with a frequency of 308 kHz.

## Output Relays

In all monopolar modes, K13 is closed and routes patient return current through the Patient Return Electrode receptacle. K15 routes active current through the Monopolar 1/CEM Instrument receptacle. K16 routes the active current through the Monopolar 2 Instrument receptacle.

In bipolar mode, the Patient Return Electrode receptacle relay is open. Relays K12 and K17 route bipolar current to the Bipolar Instrument receptacle.

All output relays are open when the generator is not being activated.

## Spark Control Circuit

The spark control uses the voltage sense circuit to monitor the output voltage. It interrupts the delivery of power if the output voltage exceeds a preset threshold. This greatly reduces sparking when an activated accessory is removed from tissue.

Sparking occurs because the RF stage tuning results in a higher natural gain at light loads than at heavy loads. Thus, during sudden transitions from heavy to light loads, the output voltage rises faster than the microcontroller can respond. This analog circuit works outside the microcontroller loop at a much greater speed.

The rectified but unfiltered waveform from the output voltage sense circuit is fed into a peak detector (U23A, CR29, and C104). A high impedance buffer (U23B) maintains the integrity of the peak detected signal. The output of this buffer is divided and fed to a comparator.

The other input to the comparator is an analog threshold level (VMAX\_CLP) that is set by the main microcontroller on the Control board and depends on the mode and power setting.

When the peak detected sample of the output voltage exceeds the threshold, one-shot U14A is fired and generates a 3 ms pulse (SPARK\_CON) that is sent to the T\_ON ASIC on the Control board. This pulse is ignored if it occurs during the first 0.2 seconds of activation. Otherwise, SPARK\_CON causes the T\_ON signal to stop.

The feedback microcontroller on the Control board senses this and realizes that a spark has been suppressed. The feedback microcontroller waits 100 ms in Pure cut, then re-initiates T\_ON with a frequency of 470 kHz. The frequency returns to 394 kHz after 1 second of continuous activation or when the generator is reactivated.

## RF Leakage Reduction Circuit

### Fulgurate and Spray Coag Modes

For the Fulgurate and Spray coag modes, the high voltage RF output pulse repetition period varies with changes in spark and patient tissue impedance to limit the RF leakage current to a desired level.

The VSENSE signal is obtained from the divider (R58, R25) located on the primary side of T4. VSENSE is input to a negative peak detector (U24A) that generates the analog signal (VPEAK-). Then U25A amplifies and inverts the signal.

The averaged signal (now called VPK+) is input to the feedback microcontroller on the Control board and added to the ECON value at the selected power setting. The sum of these signals, with the proper gain factors, varies linearly with load impedance at the patient site.

This sum is input into a pulse width modulator that sends its output (WAK) to a NAND gate. Thus, the T\_ON signal is inhibited for up to four consecutive cycles. Without the leakage control, the pulse repetition period is 17  $\mu$ s. With the leakage control fully activated, the total pulse train repeats every 84  $\mu$ s with a maximum dead time of 60% or 51  $\mu$ s.

### REM Circuit

Components U17 along with R95, R96, R97, and C79 form a precision oscillator. R96 is adjusted for the frequency that will produce maximum voltage amplitude ( $80 \pm 10$  kHz) at the REM connector (J17). R98 is a temperature compensating thermocouple that cancels temperature drift from the components forming the oscillator.

The REM transformer (T10) provides isolated reflected impedance sensing for tissue impedance across the REM patient return electrode terminals (connected to J17, pins 1 and 2). In addition to tuning the REM circuit, capacitors C155, C156, C169, and C170

provide a return path for high frequency RF signals through C 157 to the RF output transformer. The REM transformer (T10) and capacitors C 155, C 156, C 169, and C 170 form a resonant circuit with a nominal operating frequency of 80 kHz.

Pin 1 of T10 clocks the active synchronous rectifier formed by CMOS switch U28A. This device is closed during the positive period of the REM\_AC signal and open during the negative period. When the switch is closed, C 122 is charged to the peak positive value of REM\_AC. Then, U31B amplifies, filters and buffers the charge on C 122 to produce the R\_SEN signal. The microcontrollers monitor the R\_SEN signal (which is a DC voltage proportional to impedance) to determine the patient return electrode status.

## IsoBloc Circuit

The IsoBloc circuit provides a means of detecting a switch closure in an output accessory while maintaining electrical isolation between the generator output and ground referenced circuitry.

The IsoBloc circuit consists of an isolated DC power supply, a comparator to detect switch closure, and an optoisolator link from the output connected circuitry to the ground referenced low voltage circuitry. Each handswitching output of the generator is associated with its own IsoBloc power source and isolated signal paths.

## Oscillator

The oscillator circuit consists of a chain of 74HC14 inverters. The output of the oscillator yields a 67.5 kHz square wave that is applied to the input of three 4081 buffers (U29).

## Power Supply

The three 4081 buffers (U29) drive three TN2404KL FETs connected to transformers which are operated in a quasi-resonant flyback mode with their associated 6800 pF capacitors. The voltages at the secondaries of the three transformers are half-wave rectified and referenced to three separate isolated grounds to provide -8 V for operating the isolated activation circuitry.

## Optoisolators

The isolated power supply voltages produced by the IsoBloc power supplies are connected to the active output terminals of the generator. Handswitch activation is accomplished by sensing active to CUT or active to COAG switch closure in a handheld accessory.

Switch closure is detected by comparing the voltage across the switch to a divider reference with comparators U32, U33, and U34. Current through the limiting resistors, in series with the LEDs in the optoisolators, cause the LEDs to light. The phototransistor in the optoisolator detects this light.

The phototransistor, which is connected to an input on the FPGA U16-B, through the U24 Bus Transceiver, in the main microcontroller circuit turns on, pulling the associated input low. This is interpreted by the software as an activation request and the generator is activated accordingly.

## Temperature Sense Circuits

The Force FX Electrosurgical Generator C features two temperature sense circuits.

The first temperature sense circuit measures the air temperature adjacent to the RF output FET heat sink. When the temperature at this location reaches approximately 40° C, a cooling fan switches on to minimize heat buildup. The fan switches off when the temperature drops below approximately 35° C.

The second temperature sense circuit measures the air temperature near the Control board, which is located in the forward third of the generator enclosure. When this temperature reaches approximately 50° C, the main microcontroller flashes number 451 alternately with the power settings to indicate that the generator is too hot. Generator operation reverts to normal when the temperature decreases to below 40° C.

### Thermal Sensing (Fan Control)

A reference voltage is applied to the noninverting input of comparator U2A. Resistors R15 and R16 determine the reference voltage. When the temperature of NTC thermistor R19 is 40° C, the reference voltage is set to be equal to the voltage at the inverting input of U2A. Resistor R10 provides positive feedback causing approximately 5° C of hysteresis.

At temperatures below 40° C, the output of U2A is low. When the thermistor exceeds the threshold, the voltage comparator changes state causing the output at U2A to go high, turning on FET Q2. This applies 12 V to the cooling fan. When the temperature drops to 35° C, the circuit reverts to its low temperature state, and the cooling fan switches off.

### Thermal Sensing (High Temperature Limit)

A reference voltage is applied to the non-inverting input of comparator U26A. Resistors R111 and R110 determine the reference voltage. When the temperature of NTC thermistor R109 is 50° C, the reference voltage is set to be equal to the voltage at the inverting input of U26A. Resistor R94 provides positive feedback causing approximately 10° C of hysteresis.

When the thermistor exceeds the threshold, the voltage comparator changes state, causing the output at U26A to go high. The main microcontroller reads this signal (TEMP\_HI) and flashes number 451 alternately with the power settings. When the temperature drops to 40° C, the circuit reverts to its low temperature state, and the generator allows activation for an unlimited duration.

# Chapter 5

## Setup, Tests, and Adjustment

After unpacking or after servicing the Force FX Electrosurgical Generator C, set it up and verify that it functions correctly.

If the Force FX Electrosurgical Generator C does not satisfactorily complete the self-test, calibrate it to ensure its accuracy.

## Setting Up the Generator

### Warning

**Electric Shock Hazard** Connect the generator power cord to a properly grounded receptacle. Do not use power plug adapters.

**Fire Hazard** Do not use extension cords.

### Precaution

Do not stack equipment on top of the generator or place the generator on top of electrical equipment (except a Valleylab Argon Gas Delivery Unit II or a CUSA EXcel unit). These configurations are unstable and/or do not allow adequate cooling.

Provide as much distance as possible between the electrosurgical generator and other electronic equipment (such as monitors). An activated electrosurgical generator may cause interference with them.

### Notice

If required by local codes, connect the generator to the hospital equalization connector with an equipotential cable.

Connect the power cord to a wall outlet having the correct voltage. Otherwise product damage may result.

1. *Verify the generator is off by pressing the power switch off (O).*
2. Place the generator on a stable flat surface, such as a table, platform, or Covidien cart. Carts with conductive wheels are recommended. For details, refer to the procedures for your institution or to local codes.

Provide at least four to six inches of space from the sides and top of the generator for cooling. Normally, the top, sides, and rear panel are warm when the generator is used continuously for extended periods of time.

Ensure that the generator rests securely on the cart or platform. The underside of the generator contains four rubber feet and additional holes that allow you to reposition the feet to ensure stability. Use a Phillips screwdriver to remove the rubber feet from the generator. Then, reinstall the feet in the preferred location.

3. According to the procedures used by your institution, connect an equipotential grounding cable to the grounding lug on the rear panel of the generator. Then, connect the cable to earth ground.
4. Plug the generator power cord into the rear panel receptacle.
5. Plug the generator power cord into a grounded receptacle.
6. Turn on the generator by pressing the power switch on (I). Verify the following:
  - All visual indicators and displays on the front panel illuminate.

- Activation tones sound to verify that the speaker is working properly.

**Important**

If the coag mode has been optionally changed to default to Desiccate or Spray, that corresponding indicator illuminates after the self-test is performed successfully.

7. If the self-test is successful, a tone sounds. Verify the following:
  - Indicators above the default mode buttons (Standard bipolar, Pure cut, and Fulgurate coag) illuminate green.
  - Each display shows a power setting of one watt.
  - The REM Alarm indicator illuminates red.

If the self-test is not successful, an alarm tone sounds. A number may momentarily appear in the Cut display and, in most cases, the generator is disabled. Note the number and refer to *Responding to System Alarms* on page 6-11.

## Connections for Bipolar or Macro bipolar Surgery

If you plan to use a footswitching bipolar instrument, you must connect a bipolar footswitch. You may also use a handswitch to activate a handswitching instrument. Refer to the figures on this page and page 5-5.

### Warning

#### Electric Shock Hazard

- Do not connect wet accessories to the generator.
- Ensure that all accessories and adapters are correctly connected and that no metal is exposed.

### Precaution

Accessories must be connected to the proper receptacle type. In particular, bipolar accessories must be connected to the Bipolar receptacle only. Improper connection may result in inadvertent generator activation or a REM contact quality monitor alarm.

### ***Bipolar or macrobipolar connections—footswitch activation and a handswitching or footswitching instrument***

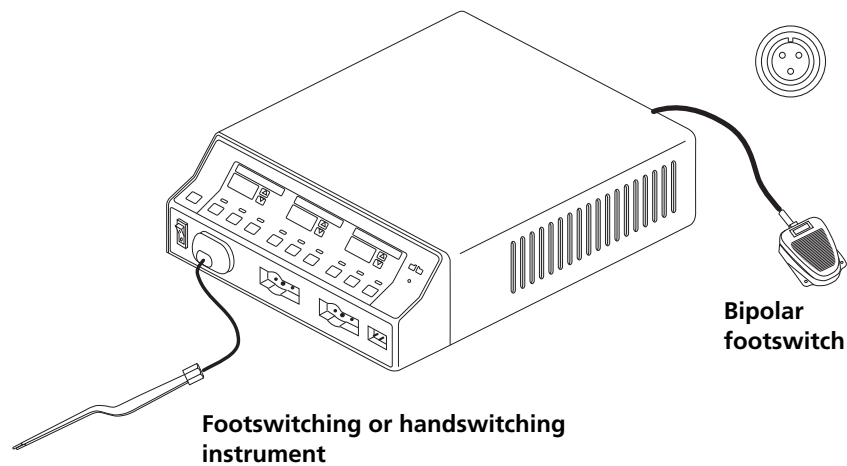

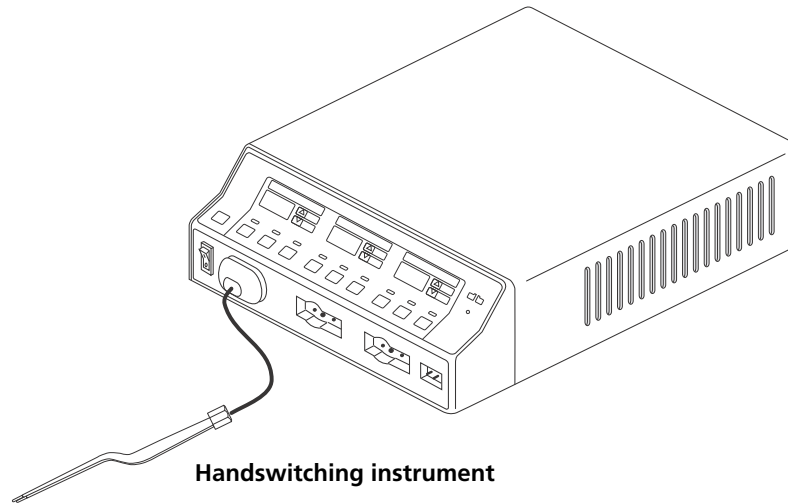
**Bipolar or macrobipolar connection—handswitching instrument****Setting the Bipolar Output****Precaution**

Set power levels to the lowest setting before testing an accessory.

1. (Optional) To display the previous settings, press the Recall button.
2. To set the Bipolar mode, press the Precise, Standard, or Macro button. The corresponding indicator illuminates green.
3. To increase the power for the selected mode, press the white up arrow (  $\Delta$  ) button. To decrease the power, press the white down arrow (  $\nabla$  ) button. The maximum power setting is 70 W.

## Connections for Monopolar Surgery

If you plan to use a footswitching monopolar instrument, you must connect a Valleylab monopolar footswitch. You may also use a footswitch to activate a handswitching instrument or a CUSA handpiece with CEM nosecone. Refer to the figures on this page and page 5-7.

### Warning

#### Electric Shock Hazard

- Do not connect wet accessories to the generator.
- Ensure that all accessories and adapters are correctly connected and that no metal is exposed.

Use only a Valleylab monopolar footswitch with the Force FX Electrosurgical Generator C generator. Use on an incompatible footswitch may cause unexpected output.

The instrument receptacles on this generator are designed to accept only one instrument at a time. Do not attempt to connect more than one instrument at a time into a given receptacle. Doing so will cause simultaneous activation of the instruments.

### **Monopolar connection—footswitch activation and a footswitching or handswitching instrument using Monopolar 1 Footswitch receptacle and Monopolar 1/CEM Instrument receptacle**

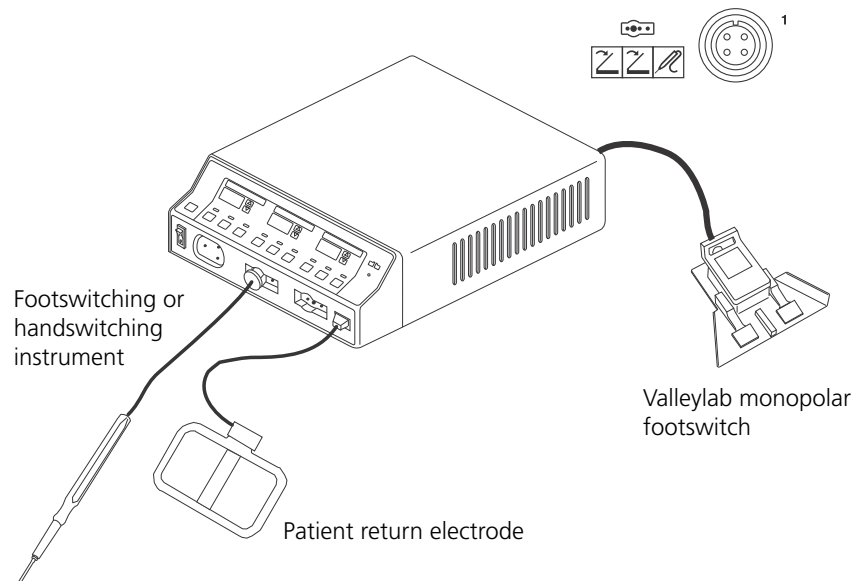

**Monopolar connection—footswitch activation and a footswitching or handswitching instrument using Monopolar 2 Footswitch receptacle and Monopolar 2 Instrument receptacle**

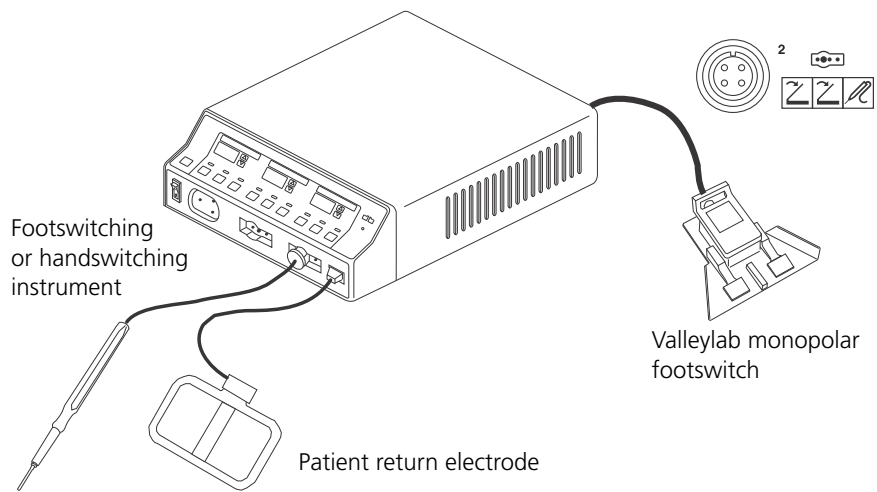

**Monopolar connection—handswitch activation and a monopolar handswitching instrument using either Monopolar Instrument receptacle**

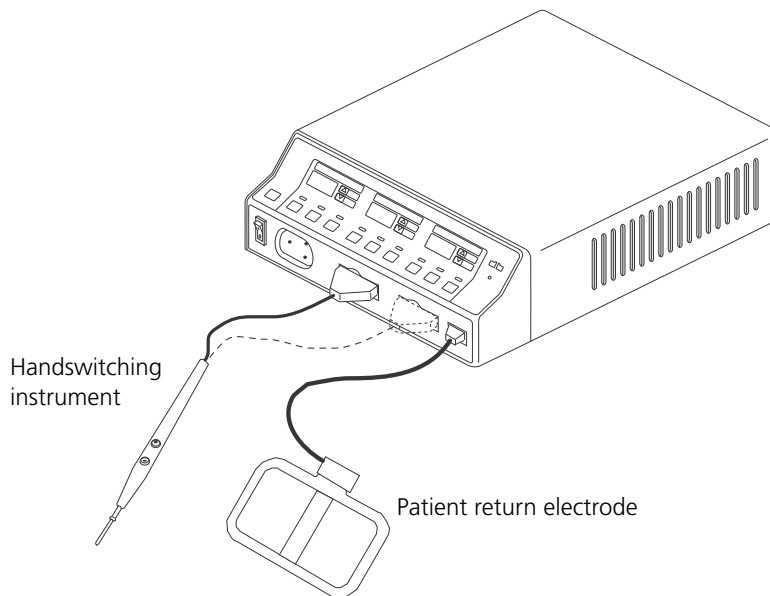

## Selecting Cut and Coag Modes

### Precaution

Set power levels to the lowest setting before testing an accessory.

1. **(Optional)** To display the previous settings, press the Recall button.
2. **To select a cut mode**, press the Low, Pure, or Blend button. The corresponding indicator illuminates green.
3. To increase the power for the cut mode you selected, press the yellow up arrow (  $\Delta$  ) button. To decrease the power, press the yellow down arrow (  $\nabla$  ) button. The maximum power setting for Low and Pure is 300 W. The maximum power setting for Blend is 200 W.
4. **To select a coag mode**, press the Low (Desiccate), Med (Fulgurate), or High (Spray) button. The corresponding indicator illuminates green.

To select the LCF Fulgurate mode, press the Med button and hold for two seconds. A tone sounds and an "L" appears on the left side of the Coag display. To return to the standard Fulgurate mode, press the Med button and hold for two seconds. A tone sounds and the "L" disappears from the left side of the Coag display.

5. To increase the power for the selected coag mode, press the blue up arrow (  $\Delta$  ) button. To decrease the power, press the blue down arrow (  $\nabla$  ) button. The maximum power setting for each coag mode is 120 W.

In the LCF Fulgurate mode, an "L" appears on the left side of the Coag display. When the LCF Fulgurate power setting is above 95 W, the power setting display alternates between the power setting (for example, 110 W) and "L--".

## Simultaneous Coag

Connect two monopolar instruments for simultaneous coag. Each receives a percentage of the overall power setting. The amount of power provided to each instrument depends on the tissue resistance sensed by the generator at each surgical site. Generally, the site with lower resistance receives proportionately more power. The combined total output power does not exceed the overall power setting for the coag mode selected.

Simultaneous Tone Details:

The simultaneous coag tone sounds and coag indicator illuminates blue upon pressing Monopolar 1 Coag and Monopolar 2 Coag handswitch buttons simultaneously, or alternatively pressing Monopolar 1 Coag and Monopolar 2 Coag footswitch pedals simultaneously.

**Connections for simultaneous coag—two handswitching instruments**

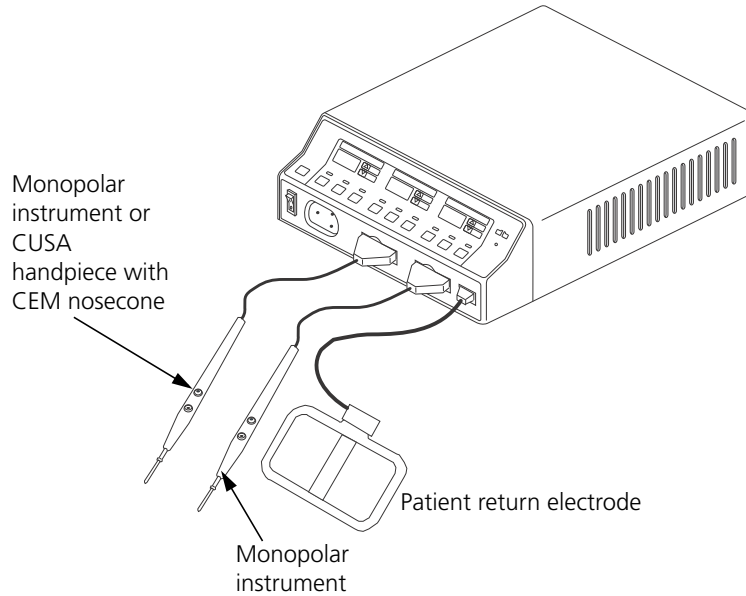

**Connection for simultaneous coag—two footswitching instruments**

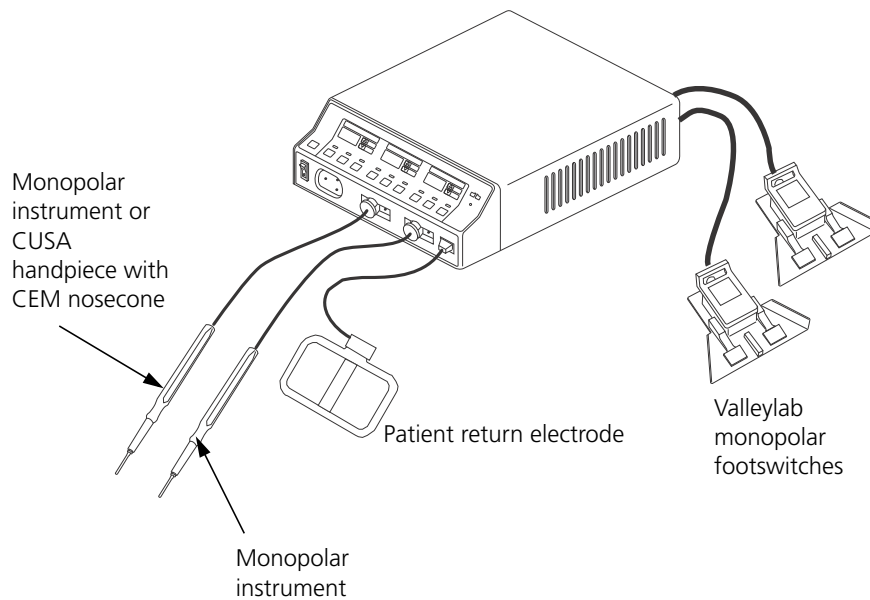

## Using Two Generators Simultaneously

### Precaution

Do not stack equipment on top of the generator or place the generator on top of electrical equipment (except a Valleylab Argon Gas Deliver Unit II or a CUSA EXcel unit). These configurations are unstable and/or do not allow adequate cooling.

Two generators (and two patient return electrodes) may be used simultaneously on the same patient, provided the generators are the same type (both are isolated or both are ground referenced).

However, the two generators are not synchronized. One return electrode frequently acquires a high positive voltage while the other acquires an opposite negative voltage.

When this occurs, the potential voltage difference between them may cause the current to flow from one patient return electrode to the other. The current causes no harm if it produces no sparks or high current densities on the patient.

Place each patient return electrode as close as possible to the site of the surgery to be performed by the generator to which it is connected. Ensure that the two patient return electrodes do not touch.

## Connecting the CUSA Handpiece with CEM Nosecone

### Warning

#### Electric Shock Hazard

- Do not connect wet accessories to the generator.
- Ensure that all accessories and adapters are correctly connected and that no metal is exposed.

### Connections for combined monopolar/ultrasonic surgery

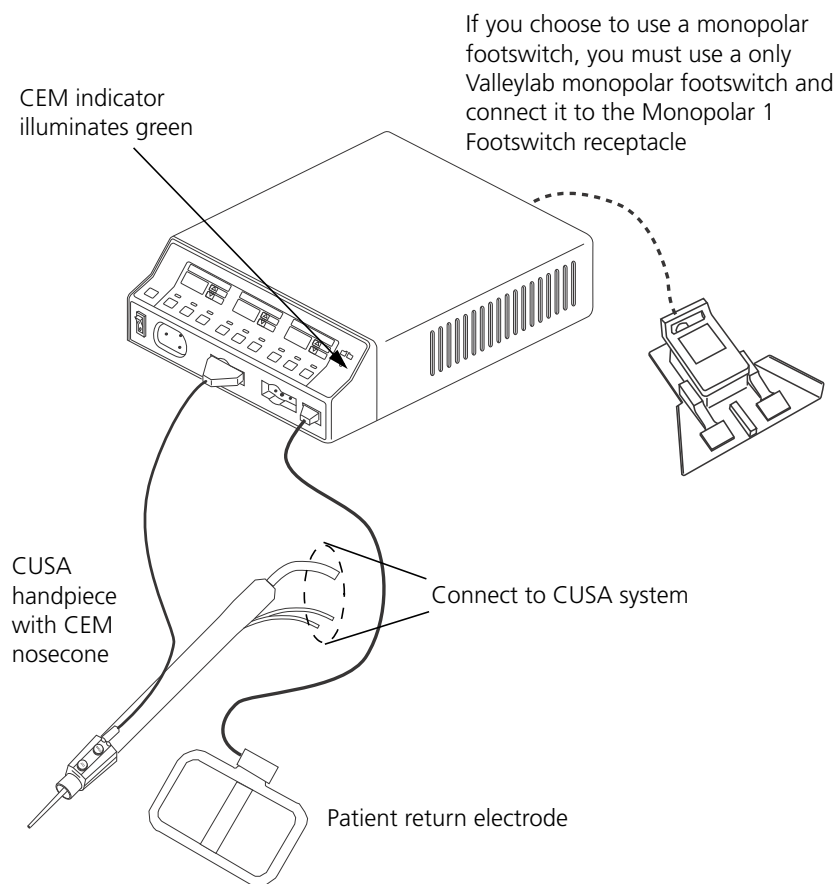

## Setting the Output Power

### Precaution

Set power levels to the lowest setting before testing an accessory.

When you use the CUSA handpiece with CEM nosecone for ultrasonic electrosurgery, only Low cut or Desiccate coag are available when you activate the handpiece.

### To verify or change the Low cut power setting:

To increase the power, press the yellow up arrow (  $\Delta$  ) button. To decrease the power, press the yellow down arrow (  $\nabla$  ) button. The maximum cut power is 100 W.

### To verify or change the Desiccate coag power setting:

To increase the power, press the blue up arrow (  $\Delta$  ) button. To decrease the power, press the blue down arrow (  $\nabla$  ) button. The maximum coag power is 70 W.

## Simultaneous Coag with a CUSA System

To use a CUSA handpiece with CEM nosecone for simultaneous coag, connect the handpiece to the Monopolar 1/CEM Instrument receptacle. Then connect a monopolar instrument to the Monopolar 2 Instrument receptacle. During simultaneous coag, only Desiccate coag is available; the maximum power is limited to 70 W.

## Changing the Mode

Verify the selected mode with the surgeon. You cannot change the mode while the generator is activated.

To change the mode, press the desired bipolar, cut, or coag mode button. The indicator above that button illuminates green. You can activate only one mode at a time.

When you change modes within a function (bipolar, cut, coag), the power setting remains the same unless it exceeds the maximum for the new mode. In that case, it reverts to the maximum for the new mode. For example, if you set the power to 250 W for Pure cut, when you select Blend, the power setting changes to 200 W, the maximum for Blend. If, however, you set the power to 65 W in Desiccate, when you select Fulgurate, the power setting does not change because it falls within that mode's range.

## Changing the Power Setting

Verify the power settings for the selected mode with the surgeon. You can change the power setting when the generator is on, including when it is activated.

**To increase the power,** press the up arrow ( $\Delta$ ) button for the selected mode.

**To decrease the power,** press the down arrow ( $\nabla$ ) button for the selected mode.

When you press and release the power button, the power changes by one setting (1, 5, or 10 W), based on the settings available for the selected mode. The available power settings are listed in Chapter 3, *Technical Specifications*.

To reach the maximum or minimum power setting for the selected mode, press and hold the up arrow ( $\Delta$ ) or down arrow ( $\nabla$ ) button. The setting changes slowly at first, then more rapidly. Release the button when the desired setting is displayed. If you try to set the power above the maximum setting or below the minimum setting for the selected mode, a tone sounds.

## Activating the Surgical Instrument

### Notice

Do not activate the generator until the forceps have made contact with the patient. Product damage may occur.

To activate a handswitching instrument, use the controls on the instrument or on the appropriate footswitch. To activate a footswitching instrument, you must use a footswitch.

To reduce the possibility of alternate site burns that may be caused by RF leakage currents, avoid unnecessary and prolonged activation of the generator.

If you use bipolar output when a return electrode is applied to the patient, the return electrode circuit is deactivated automatically to eliminate the possibility of current dispersal.

**Activation Indicators**

	<b>Handswitching</b>	<b>Footswitching</b>	<b>Activation Indicator</b>
Bipolar	Close forceps tines firmly	Press pedal	Activation tone sounds – Bipolar indicator illuminates blue
Monopolar	Press Cut or Coag button or Close forceps tines firmly	Press Cut or Coag pedal	Activation tone sounds – Cut indicator illuminates yellow or Coag indicator illuminates blue
CUSA handpiece with CEM nosecone	Press Cut or Coag button on CEM nosecone	Press Cut or Coag pedal	Activation tone sounds – Cut indicator illuminates yellow or Coag indicator illuminates blue – CEM indicator on front panel illuminates green when handpiece is properly connected
Monopolar Simultaneous Coag	Press Monopolar 1 Coag and Monopolar 2 Coag buttons simultaneously	Press Monopolar 1 Coag and Monopolar 2 Coag pedals simultaneously	Simultaneous Coag tone sounds–Coag indicator illuminates blue

## Periodic Safety Check

**Important**

When testing RF equipment, follow these test procedures to duplicate manufacturer test data. Keep test leads to the minimum length usable; lead inductance and stray capacitance can adversely affect readings. Carefully select suitable ground points to avoid ground loop error in measurements.

The accuracy of most RF instruments is approximately 1–5% of full scale. Using uncompensated scope probes causes large errors when measuring high voltage RF waveforms.

Perform the following safety check every six months to verify that the generator is functioning properly. Record the test results for reference in future tests. If the generator fails to meet any of the checks, refer to Chapter 6, *Troubleshooting*.

**Warning**

**Electric Shock Hazard** When taking measurements or troubleshooting the generator, take appropriate precautions, such as using isolated tools and equipment, using the “one hand rule,” etc.

**Warning**

**Electric Shock Hazard** Do not touch any exposed wiring or conductive surfaces while the generator is disassembled and energized. Never wear a grounding strap when working on an energized generator.

**Precaution**

The generator contains electrostatic-sensitive components. When repairing the generator, work at a static-control workstation. Wear a grounding strap when handling electrostatic-sensitive components, except when working on an energized generator. Handle circuit boards by their nonconductive edges. Use an antistatic container for transport of electrostatic-sensitive components and circuit boards.

Here is a summary of safety checks:

- Inspect the generator and accessories
- Inspect the internal components
- Test the generator
- Verify REM function
- Confirm outputs
- Check leakage current and ground resistance

**Recommended Test Equipment**

- Digital voltmeter—Fluke™\* 77 or 87, or equivalent
- True RMS voltmeter—Fluke 8920, or equivalent
- Oscilloscope—Tektronix 2445, or equivalent
- Leakage current tester—Use UL load device or commercially available leakage tester
- Leakage table—per IEC 60601-2-2, Figure 104
- 100, 200, 300, 500  $\Omega$ , all 250 watt, 1% tolerance, noninductive (Dale™\* NH-250 or equivalent)

## Inspecting the Generator and Accessories

### Equipment required

- Bipolar footswitch or monopolar footswitch
- Bipolar instrument cords (handswitching and footswitching)
- Monopolar instrument cords (handswitching and footswitching)

Turn off the generator, and disconnect the power cord from the wall receptacle.

### Rear Panel

1. Check the rear panel footswitch receptacles for obstructions or damage. Check for a secure fit by inserting the bipolar footswitch or monopolar footswitch connector into the appropriate receptacle.
2. Remove the fuse and verify correct voltage and current rating. Refer to *Performance Characteristics* on page 3-2.

If either connection is loose, replace the Footswitch board assembly. Refer to *Footswitch Board Replacement* on page 7-8.

### Front Panel

1. Check the Bipolar Instrument receptacle for obstructions or damage. Insert the bipolar instrument connector (footswitching and handswitching) into the appropriate receptacle to verify a secure fit.

If the connection is loose, replace the front panel assembly. Refer to *Front Panel Replacement* on page 7-9.

2. Check the monopolar instrument receptacles for obstructions or damage. Insert the monopolar instrument connector (footswitching and handswitching) into the appropriate receptacle to verify a secure fit.

If any of the connections are loose, replace the front panel assembly. Refer to *Front Panel Replacement* on page 7-9.

3. Check the Patient Return Electrode receptacle for a broken pin or an obstruction. If the receptacle is damaged or obstructed, replace the front panel assembly. Refer to *Front Panel Replacement* on page 7-9.

### Footswitch

1. Disconnect the footswitch from the generator.
2. Disassemble the footswitch connector. Inspect the connector for damage or corrosion.
3. Reassemble the footswitch connector.
4. Inspect the footswitch for damage.

5. Reconnect the footswitch to the generator.

## Power Cord

1. Disconnect the power cord from the unit and ensure that it is unplugged from the wall receptacle.
2. Inspect the power cord for damage.
3. Reconnect the power cord to the generator and wall receptacle.

## Inspecting the Internal Components

### Equipment required

- Phillips screwdriver

#### Precaution

The generator contains electrostatic-sensitive components. When repairing the generator, work at a static-control workstation. Wear a grounding strap when handling electrostatic-sensitive components, except when working on an energized generator. Handle circuit boards by their nonconductive edges. Use an antistatic container for transport of electrostatic-sensitive components and circuit boards.

1. Turn off the generator.
2. Loosen the five screws that secure the cover to the chassis. Lift the cover off the chassis. Set the cover aside for reinstallation.
3. Verify that all connectors are firmly seated.
4. Inspect each board for damaged components, wires, cracks, and corrosion.
  - If you find evidence of damage on the Control board, Display board, or Footswitch board, replace the board. Refer to *Control Board Replacement* on page 7-4, *Display Board Replacement* on page 7-5, or *Footswitch Board Replacement* on page 7-8.
  - If you find evidence of damage on the Power Supply/RF board, replace the board only if the damage is severe. Refer to *Power Supply/RF Board Replacement* on page 7-26.
5. Reinstall the cover on the generator. Position the cover above the chassis and slide it down. Tighten the five screws that secure the cover to the chassis.

## Testing the Generator

Turning on the generator initiates an internal self-test to verify the calibration. The self-test also checks the operation of the speaker, all indicators, and the displays.

### Warning

Use the generator only if the self-test has been completed as described. Otherwise, inaccurate power outputs may result.

### Generator Self-test

1. Turn on the generator by pressing the front panel On (I) switch. Verify the following:
  - All visual indicators and displays on the front panel illuminate.
  - Activation tones sound to verify that the speaker is working properly.

### Important

If the coag mode has been optionally changed to default to Desiccate or Spray, that corresponding indicator illuminates after the self-test is performed successfully.

2. **If the self-test is successful**, a tone sounds. Verify the following:

- Indicators above the default mode buttons (Standard bipolar, Pure cut, and Fulgurate coag) illuminate green.
- Each display shows a power setting of one watt.
- The REM Alarm indicator illuminates red.

**If the self-test is not successful**, an alarm tone sounds. A number may momentarily appear in the Cut display and, in most cases, the generator is disabled. Note the number and refer to *Responding to System Alarms* on page 6-11.

If you removed and/or replaced the battery, alarm number 212 may appear in the Cut display when you turn on the generator. If this happens, calibrate the generator.

## Verifying REM Function

### Equipment required

REM plug and resistance substitution box.

1. Set the resistance substitution box to 120  $\Omega$ . Connect the resistance box to the generator and confirm that the REM indicator illuminates green.
2. Slowly increase the resistance and verify that the REM alarm sounds at  $135 \pm 5 \Omega$ .
3. Decrease the resistance to 60  $\Omega$  and verify that the REM indicator illuminates green.
4. Increase the resistance to 100  $\Omega$  and verify that the REM alarm sounds.
5. Decrease the resistance to 30  $\Omega$  and verify that the REM indicator illuminates green.
6. Decrease the resistance to 10  $\Omega$  and verify that the REM indicator illuminates green.
7. Decrease the resistance to 3  $\Omega$  and verify that the REM alarm sounds.
8. Switch to a connector without the pin, and increase the resistance from 3  $\Omega$  to 24  $\Omega$ . Verify that the REM alarm sounds.

## Confirming Outputs

Use this procedure to ensure the accuracy of the generator. Always confirm the output:

- After calibrating the generator
- Every six months

### Equipment required

- Two small test cables (less than 24" [61 cm] long) with banana plugs
- Current transformer
- True RMS voltmeter (such as the Fluke 8920 or equivalent)
- 100, 300, and 500  $\Omega$  1% noninductive power resistors
- Bipolar footswitch and monopolar footswitch

## Checking the Bipolar Output

1. Verify that the generator successfully completes the self-test as described in *Generator Self-test* on page 5-18 in this section.
2. Connect the test equipment for bipolar output.
  - a. Connect the two test cables to the Bipolar Instrument receptacle.
  - b. Pass one test cable through the current transformer and connect the current transformer to the voltmeter.

- c. Connect the 100  $\Omega$  power resistor across the output jacks at the end of the test cables.
      - d. Connect the bipolar footswitch to the Bipolar Footswitch receptacle on the rear panel.
  3. Press the Precise button and set the bipolar power to 10 W.
  4. Test the output current for the selected Bipolar mode.
    - a. Press the footswitch pedal and, while activating the generator, note the output on the voltmeter.
    - b. Release the footswitch pedal.
    - c. Based on the voltmeter setting and the current transformer you are using, calculate and record the output current.
  5. Press the Standard button and repeat step 4 (above).
  6. Press the Macro button and repeat step 4 (above).
  7. Verify that the generator output for each mode is  $315 \pm 24$  mA<sub>rms</sub>.

If the output is outside the specified range, calibrate the bipolar output as described in *Calibrating the Generator* on page 5-26. Then repeat this procedure. If the output for one or more modes remains outside the specified range, call the Covidien Service Center.

## Checking Output for the Monopolar Cut Modes

1. Verify that the generator successfully completes the self-test as described in *Generator Self-test* on page 5-18.
2. Connect the test equipment for monopolar output.
  - a. Connect one test cable to the left jack in the Monopolar 1/CEM Instrument receptacle. Pass the test cable through the current transformer and connect the current transformer to the voltmeter.
  - b. Use a test cable to short the two pins on the Patient Return Electrode receptacle.
  - c. Connect the second test cable from the voltmeter to both pins of the Patient Return Electrode receptacle.
  - d. Connect the 300  $\Omega$  resistor across the output jacks at the end of the test cables.
  - e. Connect the monopolar footswitch to the Monopolar 1 Footswitch receptacle on the rear panel of the generator.
3. Press the Pure button.
4. Press the Cut up ( $\Delta$ ) or down ( $\nabla$ ) arrow buttons to set the cut power to 75 W.
5. Test the monopolar cut output.
  - a. Press the footswitch cut pedal and, while activating the generator, note the output on the voltmeter.

- b.** Release the footswitch pedal.
  - c.** Based on the voltmeter setting and the current transformer you are using, calculate and record the output current.
- 6.** Press the Low cut button and repeat step 5 (above).
- 7.** Press the Blend button and repeat step 5 (above).
- 8.** Verify that the generator output for each mode is  $499 \pm 38$  mA<sub>rms</sub>.

If the output is outside the specified range, calibrate the monopolar output as described in *Calibrating the Generator* on page 5-26. Then repeat this procedure. If the output for one or more cut modes remains outside the specified range, call the Covidien Service Center.

## Checking Output for the Monopolar Coag Modes

1. Complete steps 1 and 2 of *Checking Output for the Monopolar Cut Modes* on page 5-20, replacing 300  $\Omega$  resistor with 500  $\Omega$  resistor in item 2d.
2. Press the Low (Desiccate) button.
3. Press the Coag up ( $\Delta$ ) or down ( $\nabla$ ) arrow buttons to set the coag power to 30 W.
4. Test the monopolar coag output.
  - a. Press the footswitch coag pedal and, while activating the generator, note the output on the voltmeter.
  - b. Release the footswitch pedal.
  - c. Based on the voltmeter setting and the current transformer you are using, calculate and record the output current.
5. Press the Med (Fulgurate) button and repeat step 4 (above).
6. Press the Med (Fulgurate) button and hold for two seconds. After the tone sounds and the "L" appears on the left side of the Coag display, repeat step 4 (above).
7. Press the High (Spray) button and repeat step 4 (above).
8. *Verify that the generator output for each mode is  $245 \pm 19 \text{ mA}_{rms}$ .*

If the output is outside the specified range, calibrate the monopolar output as described in *Calibrating the Generator* on page 5-26. Then repeat this procedure. If the output for one or more coag modes remains outside the specified range, call the Covidien Service Center.

## Checking Low Frequency Leakage Current and Ground Resistance

Check the low frequency leakage current and ground resistance before returning the generator to clinical use.

### Equipment required

- DVM
- Leakage current tester

### Leakage current test circuit per IEC 60601-1

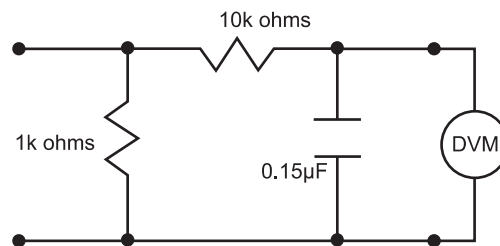

1 millivolt = 1 microamp

## Output Receptacles and REM Source Current

1. Set the DVM to AC volts (200 millivolts [mV]) and connect the leakage current test circuit.
2. Turn on the generator.
3. Measure between all the output receptacles (including the Patient Return Electrode receptacle) and earth ground. Record the largest reading.
4. Determine the leakage current using the conventional 1 microamp ( $\mu\text{A}$ ) per 1 mV.
5. Verify under normal conditions (ground closed, normal polarity) the leakage current is less than 10  $\mu\text{A}$ . If the leakage current is greater than 10  $\mu\text{A}$ , call the Covidien Service Center.
6. Verify single fault conditions (ground open) the leakage current is less than or equal to 50  $\mu\text{A}$ . If the leakage current is greater than 50  $\mu\text{A}$ , call the Covidien Service Center.

### **Chassis or Earth Leakage**

1. Set the DVM to AC volts (200 mV) and connect the leakage current test circuit.
2. Turn on the generator.
3. Measure between the chassis and earth ground.
4. Determine the leakage current using the conventional 1  $\mu\text{A}$  per 1 mV.
5. Verify under normal conditions (ground closed, normal polarity) the leakage current is less than 100  $\mu\text{A}$ . If the leakage current is greater than 100  $\mu\text{A}$ , call the Covidien Service Center.
6. Verify single fault conditions (ground open) the leakage current is less than or equal to 300  $\mu\text{A}$ . If the leakage current is greater than 300  $\mu\text{A}$ , call the Covidien Service Center.

### **Output Receptacles and REM Sink Current**

1. Set the DVM to AC volts (200 mV) and connect the leakage current test circuit.
2. Turn on the generator and connect the end of the leakage current test circuit to mains voltage through a 120 k $\Omega$  resistor.
3. Connect the other side of the IEC leakage load to all of the output receptacles (including the Patient Return Electrode receptacle).
4. Determine the leakage current using the conventional 1  $\mu\text{A}$  per 1 mV.
5. Verify the leakage current is less than or equal to 20  $\mu\text{A}$ . If the leakage current is greater than 20  $\mu\text{A}$ , call the Covidien Service Center.

### **Checking High Frequency Leakage Current**

Check the high frequency leakage current and ground resistance before returning the generator to clinical use. Check the leakage current:

- After calibrating the generator
- Every six months

#### **Equipment required**

- 200  $\Omega$ , 250 watt, noninductive resistor
- Current transformer
- True RMS voltmeter (Fluke 8920 or equivalent)
- Bipolar and monopolar footswitches
- Leakage table - per IEC 60601-2-2, Figure 104.

### Checking Monopolar High Frequency Leakage Current

1. Connect the 200  $\Omega$  load from the active accessory through the current transformer to the equipotential ground lug on the rear of the generator.
2. Connect the current transformer to a true RMS voltmeter.
3. Connect a monopolar footswitch to the Monopolar 1 Footswitch receptacle on the rear panel.
4. Activate the footswitch in each Monopolar mode at the maximum control setting. Record the leakage current. If using the leakage table, leakage current should not exceed 150 mA for any mode.
5. If the high frequency leakage exceeds 150 mA, call the Covidien Service Center for further instructions.

### Checking Bipolar High Frequency Leakage Current

1. Remove the monopolar accessories, and connect the 200  $\Omega$  load from one side of the bipolar output through the current transformer to the equipotential ground lug on the rear of the generator.
2. Connect the current transformer to the true RMS voltmeter.
3. Connect a bipolar footswitch to the Bipolar Footswitch receptacle on the rear panel.
4. Activate the footswitch in each mode at maximum control setting. Record the leakage current. It should not exceed 60 mA for any mode using either the leakage table or short lead configuration.
5. If the high frequency leakage exceeds 60 mA, call the Covidien Service Center for further instructions.

## Calibrating the Generator

There are eight calibration steps. During calibration you verify information specific to the generator, adjust the date, and adjust the clock. You also adjust the REM circuit and several values, or factors, that ensure the proper operation of the generator.

The calibration steps and the values you can adjust are summarized below. Certain values are not adjustable but must be verified.

### Notice

After completing any calibration step, proceed to the next step to save the values from the completed calibration step.

Calibration Step and Description	Adjustable?
<b>1. Generator data</b>	
Generator model number	No (verify value)
Master microcontroller software version	No (verify value)
Feedback microcontroller software version	No (verify value)
<b>2. Calendar</b>	
Month	Yes
Day of the month	Yes
Year	Yes
<b>3. Clock</b>	
Hour	Yes
Minute	Yes
<b>4. REM oscillator frequency and impedance</b>	Yes
<b>5. Current sense gain factor</b>	Yes
<b>6. Voltage sense gain factor</b>	Yes
<b>7. Reactance gain factor</b>	Yes
<b>8. ECON factor</b>	Yes

## Preparing for Calibration

### Equipment required

- Bipolar footswitch and monopolar footswitch
- Two small test cables (less than 24" [61 cm] long) with banana plugs
- REM plug (modified)
- Resistor substitution box
- Oscilloscope
- True RMS voltmeter (such as the Fluke 8920A or equivalent)
- Current transformer (such as the Pearson™\* Model 411 or equivalent)
- Noninductive power resistors (such as a Dale NH-250) with these values (in  $\Omega$ ): 10, 20, 30, 100, 200, 500, 1000, 1500, 1800, 2000, 2200, and 3000

If these exact values are not available, you may substitute series or parallel combinations of other values.

## Entering Calibration Mode

When you are in calibration mode, the calibration step number appears in the Bipolar display. The value(s) associated with each calibration step appears in the Cut and Coag displays. You use the Cut and Coag up ( $\Delta$ ) or down ( $\nabla$ ) arrow buttons to adjust the displayed values.

1. If the generator is off, turn it on.

If you removed and/or replaced the battery, alarm number 212 will appear in the Cut display the first time you turn on the generator. Turn off, then turn on the generator to clear the number. Then calibrate the generator.

If any other number appears, calibrate the generator before taking the appropriate action to respond to the number.

2. To enter calibration mode, simultaneously press the Recall, Pure, and Low (Desiccate) buttons.

The first calibration step number (C1) appears in the Bipolar display. For instructions on completing this step, refer to the first calibration step, *Verifying the Generator Data* on page 5-28.

If an error occurs during calibration, an alarm number will appear in the Cut display. Note the number and refer to Chapter 6, *Troubleshooting*.

### Notice

After completing any calibration step, proceed to the next step to save the values from the completed calibration step.

## Exiting Calibration Mode

You can exit calibration mode at any time. If you want to save the new values for a particular calibration step, press the Bipolar up arrow ( $\Delta$ ) button at the end of that step before exiting calibration mode. Calibration values are saved one step at a time.

For example, if you only want to adjust the clock, first enter calibration mode and press the Bipolar up arrow ( $\Delta$ ) button until the generator displays calibration step 3 (C3). Next, change the hour and/or minute values. Then press the Bipolar up arrow ( $\Delta$ ) button. This saves the changes for calibration step 3 (C3) and displays the next calibration step (C4). After saving the changes, turn off the generator to exit calibration mode.

If you do not want to save the changes you make for a particular calibration step, turn off the generator [do not press the Bipolar up arrow ( $\Delta$ ) button at the end of the step]. The values that were in effect before you started that step remain in effect.

### Notice

After calibration, the generator will be ready to use only after you initiate the internal self-test by turning the generator off, then on.

To save the changes for the present calibration step, press the bipolar up arrow ( $\Delta$ ) button to display the next calibration step number. Then, turn off the generator to exit calibration mode.

or

To exit calibration mode without saving the changes for the present calibration step, turn off the generator.

## Verifying the Generator Data

In calibration step 1 (C1), you verify the generator model number and the software version numbers for the main and feedback microcontrollers. You cannot adjust these values:

- The generator code (model number) for the Force FX Electrosurgical Generator C generator is 4.
- The software version number for the main microcontroller may vary among manufacturing lots, but should never be 0.
- The software version number for the feedback microcontroller may vary among manufacturing lots, but should never be 0.

If one or more of the values that appear as you complete this calibration step are not correct, call the Covidien Service Center.

1. In the Bipolar display, verify that the calibration step number is C1.
2. In the Cut display, verify that the generator model number is 4.
3. In the Coag display, verify that the main microcontroller version number is a value other than 0.

4. To display the feedback microcontroller version number, press the Med (Fulgurate) button. Verify that the version number in the Coag display is a value other than 0.
5. To proceed to the next calibration step, press the Bipolar up arrow ( $\Delta$ ) button.  
At the end of each calibration step, press the Bipolar up arrow ( $\Delta$ ) button to advance to the next step. If you need to return to a previous calibration step, press the Bipolar down arrow ( $\nabla$ ) button.

The Bipolar up arrow ( $\Delta$ ) button cycles through the calibration steps. For example, when you reach step C10 and press the Bipolar up arrow ( $\Delta$ ) button, the generator returns to step C1.

Next, check the month, day, and year values as described in *Adjust the Calendar*.

## Adjusting the Calendar

The month, day of the month, and year values are stored in the real-time clock on the Control board.

1. Verify that the Bipolar display shows calibration step number C2.
2. To select the month, press the Coag up (D) or down ( $\tilde{N}$ ) arrow buttons until the correct value (1–12) appears in the Coag display.
3. To display the day value, press the Med (Fulgurate) button.
4. To select the day, press the Coag up (D) or down ( $\tilde{N}$ ) arrow buttons until the correct value (1–31) appears in the Coag display.
5. To display the year value, press the High (Spray) button. Initially, the Coag display may show a value outside the normal range of 0 to 99. Ignore the displayed value.
6. To select the year, press the Coag up (D) or down ( $\tilde{N}$ ) arrow buttons until the correct value (0–99) appears in the Coag display.
7. Examples:
  - For 1997, set the year value to 97.
  - For 2001, set the value to 1.
8. To save the month, day, and year values and go to the next calibration step, press the Bipolar up arrow ( $\Delta$ ) button.

Next, check the hour and minute values as described in *Adjusting the Clock* on page 5-30.

## Adjusting the Clock

The hour and minute values are stored in the real-time clock on the Control board. The clock was originally set for Mountain Standard Time. The clock is configured to the 24-hour (i.e., military time) format.

1. Verify that the Bipolar display shows calibration step number C3.
2. To select the hour, press the Coag up ( D ) or down ( Ñ ) arrow buttons until the correct value (0–23) appears in the Coag display.  
Examples:
  - For 2 AM, set the hour value to 2.
  - For 2 PM, set the value to 14.
3. To display the minute value, press the Med (Fulgurate) button.
4. To select the minute value, press the Coag up ( Δ ) or down ( ∇ ) arrow buttons until the correct value (0–59) appears in the Coag display.
5. To save the hour and minute values and go to the next calibration step, press the Bipolar up arrow ( Δ ) button.

Next, check the REM impedance as described in *Check and Adjust the REM Oscillator Frequency and Impedance*.

## Checking and Adjusting the REM Oscillator Frequency and Impedance

### Equipment required

- Oscilloscope
- REM plug (modified) or two small (24" [ $< 61$  cm]) test cables
- Resistor substitution box

### Warning

**Electric Shock Hazard** Do not touch any exposed wiring or conductive surfaces while the generator is disassembled and energized. Never wear a grounding strap when working on an energized generator.

1. Verify the following:
  - The Bipolar display shows calibration step number C4.
  - The Coag display shows the letters OP (open circuit).
2. Calibrate the REM oscillator frequency:
  - a. Connect an oscilloscope across the Patient Return Electrode receptacle pins.
  - b. Remove the five screws that secure the cover to the chassis and lift the cover off the chassis.

- c. On the Power Supply/RF board, adjust potentiometer R96 for maximum amplitude of the voltage waveform across the Patient Return Electrode receptacle pins. The frequency of this waveform should be approximately 82 kHz.
  - d. Remove the oscilloscope.
  - e. Install the cover by positioning it above the chassis and sliding it down. Install the five screws that secure the cover to the chassis.
3. Open circuit the REM connection. Press the Coag up arrow ( $\Delta$ ) button once. Verify that 10 appears in the Coag display.
  4. Connect the resistor substitution box across the two terminals in the Patient Return Electrode receptacle using a modified REM plug or two test cables.
  5. Set the resistor substitution box to 10  $\Omega$ . Press the Coag up arrow ( $\Delta$ ) button once. Verify that 70 appears in the Coag display.
  6. Set the resistor substitution box to 70  $\Omega$ . Press the Coag up arrow ( $\Delta$ ) button once. Verify that 135 appears in the Coag display.
  7. Set the resistor substitution box to 135  $\Omega$ .
  8. To save the REM calibration values and go to the next calibration step, press the Bipolar up arrow ( $\Delta$ ) button.

Next, check the current sense gain factor as described in *Check and Adjust the Current Sense Gain Factor*.

## Checking and Adjusting the Current Sense Gain

### Equipment required

- Two short test cables (less than 24" [61 cm] long) with banana plugs
- Current transformer (such as the Pearson Model 411 or equivalent)
- True RMS voltmeter (such as the Fluke 8920 or equivalent)
- 10  $\Omega$  noninductive power resistor (such as the Dale NH-250)
- Bipolar footswitch and monopolar footswitch

#### Precaution

To avoid inadvertent coupling and/or shunting of RF currents around the resistor elements, keep the resistors at least 4" (10.2 cm) away from any metal surface including tabletops and other resistors. This is especially true if several resistors are connected in series or parallel to obtain a specified value. Do not allow the resistor bodies to touch each other.

#### Notice

Do not activate the generator with any load resistor higher than 10  $\Omega$  while calibrating the current sense gain. Otherwise, product damage will result.

Do not adjust the current sense gain while the generator is activated.

Verify that the Bipolar display shows calibration step number C5. The Cut and Coag displays show the I (current) factor. If it is four or more digits, the most significant digits appear in the Cut display.

### Checking the Current Sense Gain for Bipolar Output

1. Connect the test equipment for bipolar output.
  - a. Connect the two test cables to the Bipolar Instrument receptacle.
  - b. Pass one test cable through the current transformer and connect the current transformer to the voltmeter.
  - c. Connect the 10  $\Omega$  resistor across the output jacks at the end of the test cables.
  - d. Connect the bipolar footswitch to the Bipolar Footswitch receptacle on the rear panel.
2. Check and adjust the I factor for bipolar output.
  - a. Press the Med (Standard) button.
  - b. Press the bipolar footswitch pedal and check the voltmeter for a reading equivalent to  $1790 \pm 20 \text{ mA}_{\text{RMS}}$ .
  - c. Stop activation. Do one of the following:
    - If the output current reading was too high, raise the I factor by pressing the Coag up arrow (  $\Delta$  ) button.
    - If the reading was too low, lower the I factor by pressing the Coag down arrow (  $\nabla$  ) button.

Repeat this step until the voltmeter reading is within the stated range. The I factor for the Precise and Macro modes is adjusted automatically.

3. Disconnect the test cables from bipolar output.

### Checking the Current Sense Gain for Monopolar Output

1. Connect the test equipment for monopolar output.
  - a. Connect one test cable to the left jack in the Monopolar 1/CEM Instrument receptacle. Pass the test cable through the current transformer and connect the current transformer to the voltmeter.
  - b. Use a test cable to short the two pins on the Patient Return Electrode receptacle.
  - c. Connect the second test cable from the voltmeter to both pins of the Patient Return Electrode receptacle.
  - d. Verify that the 10  $\Omega$  resistor is connected to the test cables through the current transformer for monopolar output.
  - e. Connect a monopolar footswitch to the Monopolar 1 Footswitch receptacle on the rear panel.

2. Check and adjust the I factor for the Low and Pure cut modes.
  - a. Press the Pure button.
  - b. Press the footswitch cut pedal and check the voltmeter for a reading equivalent to  $1250 \pm 8 \text{ mA}_{\text{rms}}$ .
  - c. Stop activation. Do one of the following:
    - If the output current reading was too high, raise the I factor by pressing the Coag up (D) arrow button.
    - If the reading was too low, lower the I factor by pressing the Coag down arrow ( $\nabla$ ) button.

Repeat this step until the voltmeter reading is within the stated range. The I factor for the Low cut mode is adjusted automatically.

3. Check and adjust the I factor for the Blend mode.
  - a. Press the Blend button.
  - b. Press the footswitch cut pedal and check the voltmeter for a reading equivalent to  $1000 \pm 8 \text{ mA}_{\text{rms}}$ .
  - c. Stop activation. Do one of the following:
    - If the output current reading was too high, raise the I factor by pressing the Coag up arrow ( $\Delta$ ) button.
    - If the reading was too low, lower the I factor by pressing the Coag down arrow ( $\nabla$ ) button.

Repeat this step until the voltmeter reading is within the stated range.

4. Disconnect the test cables and remove the  $10 \Omega$  resistor.
5. To save the current sense gain calibration and go to the next calibration step, press the Bipolar up arrow ( $\Delta$ ) button.

Next, check the voltage sense gain factor as described in *Check and Adjust the Voltage Sense Gain*.

## Checking and Adjusting the Voltage Sense Gain

### Equipment required

- Two short test cables (less than 24" [61 cm] long) with banana plugs
- Current transformer (such as the Pearson Model 411 or equivalent)
- True RMS voltmeter (such as the Fluke 8920 or equivalent)
- 1000, 2000, and 3000  $\Omega$  noninductive power resistors (such as the Dale NH-250)
- Bipolar footswitch and monopolar footswitch

**Notice**

Do not adjust the voltage sense gain while the generator is activated.

Verify that the Bipolar display shows calibration step C6. The Cut and Coag displays show the V (output voltage) factor. If it is four or more digits, the most significant digits are in the Cut display.

## Checking the Voltage Sense Gain for Bipolar Output

**Notice**

Do not activate the generator with any load resistor lower than 1000  $\Omega$  while calibrating the voltage sense gain for bipolar output. Otherwise, product damage will result.

1. Connect the test equipment for bipolar output.
  - a. Connect the two test cables to the Bipolar Instrument receptacle.
  - b. Pass one test cable through the current transformer and connect the current transformer to the voltmeter.
  - c. Connect the 1000  $\Omega$  resistor across the output jacks at the end of the test cables.
  - d. Connect the bipolar footswitch to the Bipolar Footswitch receptacle on the rear panel.
2. Check and adjust the V factor for bipolar output.
  - a. Press the Standard button.
  - b. Press the bipolar footswitch pedal and check the voltmeter for a reading equivalent to  $98 \pm 14 \text{ mA}_{\text{rms}}$ .
  - c. Stop activation. Do one of the following:
    - If the output current reading was too high, raise the V factor by pressing the Coag up arrow ( $\Delta$ ) button.
    - If the reading was too low, lower the V factor by pressing the Coag down arrow ( $\nabla$ ) button.

Repeat this step until the voltmeter reading is within the stated range. The V factor for the Precise and Macro modes adjusts automatically.

3. Disconnect the test cables and remove the 1000  $\Omega$  resistor.

## Checking the Voltage Sense Gain for Monopolar Output

### Notice

Do not activate the generator with any load resistor lower than 3000  $\Omega$  while calibrating the voltage sense gain for the Low and Pure cut modes. Do not activate the generator with any load resistor lower than 2000  $\Omega$  while calibrating the voltage sense gain for the Blend mode. Otherwise, product damage will result.

1. Connect the test equipment for monopolar output.
  - a. Connect one test cable to the left jack in the Monopolar 1/CEM Instrument receptacle. Pass the test cable through the current transformer and connect the current transformer to the voltmeter.
  - b. Use a test cable to short the two pins on the Patient Return Electrode receptacle.
  - c. Connect the second test cable from the voltmeter to both pins of the Patient Return Electrode receptacle.
  - d. Connect the 3000  $\Omega$  resistor to the test cables through the current transformer for monopolar output.
  - e. Connect a monopolar footswitch to the Monopolar 1 Footswitch receptacle on the rear panel.
2. Check and adjust the V factor for the Low and Pure cut modes.
  - a. Press the Pure button.
  - b. Press the footswitch cut pedal and check the voltmeter for a reading equivalent to  $216 \pm 3 \text{ mA}_{\text{rms}}$ .
  - c. Stop activation. Do one of the following:
    - If the output current reading was too high, raise the V factor by pressing the Coag up arrow ( $\Delta$ ) button.
    - If the reading was too low, lower the V factor by pressing the Coag down arrow ( $\nabla$ ) button.

Repeat this step until the voltmeter reading is within the stated range. The V factor for the Low cut mode is adjusted automatically.

3. Replace the 3000  $\Omega$  resistor with the 2000  $\Omega$  resistor.
4. Check and adjust the V factor for the Blend mode.
  - a. Press the Blend button.
  - b. Press the footswitch cut pedal and check the voltmeter for a reading equivalent to  $300 \pm 3 \text{ mA}_{\text{rms}}$ .
  - c. Stop activation. Do one of the following:
    - If the output current reading was too high, raise the V factor by pressing the Coag up arrow ( $\Delta$ ) button.
    - If the reading was too low, lower the V factor by pressing the Coag down arrow ( $\nabla$ ) button.

Repeat this step until the voltmeter reading is within the stated range.

5. Disconnect the test cables and remove the 2000  $\Omega$  resistor.
6. To save the voltage sense gain calibration and go to the next calibration step, press the Bipolar up arrow ( $\Delta$ ) button.

Next, go to *Check and Adjust the Reactance Gain*.

## Checking and Adjusting the Reactance Gain

### Equipment required

- Two short test cables (less than 24" [61 cm] long) with banana plugs
- Current transformer (such as the Pearson Model 411 or equivalent)
- True RMS voltmeter (such as the Fluke 8920 or equivalent)
- 30 and 200  $\Omega$  noninductive power resistors (such as the Dale NH-250)
- Bipolar footswitch and monopolar footswitch

#### Notice

Do not adjust the reactance gain while the generator is activated.

Verify that the Bipolar display shows calibration step C7. The Cut and Coag displays show the Z (reactance) factor. If it is four or more digits, the most significant digits are shown in the Cut display.

## Checking the Reactance Gain for Bipolar Output

1. Connect the test equipment for bipolar output.
  - a. Connect the two test cables to the Bipolar receptacle.
  - b. Pass one test cable through the current transformer and connect the current transformer to the voltmeter.
  - c. Connect the 30  $\Omega$  resistor across the output jacks at the end of the test cables.
  - d. Connect the bipolar footswitch to the Bipolar Footswitch receptacle.
2. Adjust the Z factor for bipolar output.
  - a. Press the Standard button.
  - b. Press the bipolar footswitch pedal and check the voltmeter for a reading equivalent to  $1250 \pm 12 \text{ mA}_{\text{rms}}$ .
  - c. Stop activation. Do one of the following:
    - If the output current reading was too high, lower the Z factor.
    - If the reading was too low, raise the Z factor.

To change the Z factor by ones, press the Coag up ( $\Delta$ ) or down ( $\nabla$ ) arrow buttons.

To change it by hundreds, press the Cut up ( $\Delta$ ) or down ( $\nabla$ ) arrow buttons.

Repeat this step until the voltmeter reading is within the stated range. The Z factor for the Precise and Macro modes is adjusted automatically.

3. Disconnect the test cable and remove the 30  $\Omega$  resistor.

## Checking the Reactance Gain for Monopolar Output

1. Connect the test equipment for monopolar output.
  - a. Connect one test cable to the left jack in the Monopolar 1/CEM Instrument receptacle. Pass the test cable through the current transformer and connect the current transformer to the voltmeter.
  - b. Use a test cable to short the two pins on the Patient Return Electrode receptacle.
  - c. Connect the second test cable from the voltmeter to both pins of the Patient Return Electrode receptacle.
  - d. Connect the 200  $\Omega$  resistor to the test cables through the current transformer for monopolar output.
  - e. Connect a monopolar footswitch to the Monopolar 1 Footswitch receptacle on the rear panel.
2. Adjust the Z factor for the Low and Pure cut modes. Press the Pure button.
  - a. Press the footswitch cut pedal and check the voltmeter for a reading equivalent to  $949 \pm 3 \text{ mA}_{\text{RMS}}$ .
  - b. Stop activation. Do one of the following:
    - If the output current reading was too high, lower the Z factor.
    - If the reading was too low, raise the Z factor.

To change the Z factor by ones, press the Coag up ( $\Delta$ ) or down ( $\nabla$ ) arrow buttons.

To change it by hundreds, press the Cut up ( $\Delta$ ) or down ( $\nabla$ ) arrow buttons.

Repeat this step until the voltmeter reading is within the stated range. The Z factor for the Low cut mode is adjusted automatically.
3. Adjust the Z factor for the Blend mode.
  - a. Press the Blend button.
  - b. Press the footswitch cut pedal and check the voltmeter for a reading equivalent to  $1000 \pm 10 \text{ mA}_{\text{RMS}}$ .

- c. Stop activation. Do one of the following:
  - If the output current reading was too high, lower the Z factor.
  - If the reading was too low, raise the Z factor.To change the Z factor by ones, press the Coag up ( $\Delta$ ) or down ( $\nabla$ ) arrow buttons.  
To change it by hundreds, press the Cut up ( $\Delta$ ) or down ( $\nabla$ ) arrow buttons.  
Repeat this step until the voltmeter reading is within the stated range.
4. Disconnect the test cables and remove 200  $\Omega$  resistor.
5. To save the reactance gain calibration and go to the next calibration step, press the Bipolar up arrow ( $\Delta$ ) button.

Next, go to *Check and Adjust the ECON Factor*.

## Checking and Adjusting the ECON Factor

### Equipment required

- Two short test cables (less than 24" [61 cm] long) with banana plugs
- 30, 100, and 500  $\Omega$  noninductive power resistors (such as the Dale NH-250)
- Bipolar footswitch and monopolar footswitch
- Current transformer (such as the Pearson Model 411 or equivalent)
- True RMS voltmeter (such as the Fluke 8920 or equivalent)

Verify that the Bipolar display shows calibration step C8.

### Checking Bipolar Output

1. Connect the test equipment for bipolar output.
  - a. Connect the two test cables to the Bipolar Instrument receptacle.
  - b. Connect the 30  $\Omega$  resistor across the output jacks at the end of the test cables.
  - c. Connect the bipolar footswitch to the Bipolar Footswitch receptacle.
2. Press the Precise button.
3. Check the ECON for the selected bipolar mode.
  - a. Verify that the Coag display shows 30.
  - b. Use the bipolar footswitch to activate bipolar output for between two and five seconds.
  - c. Stop activation. Verify that the Coag display changed to 70.
  - d. Use the bipolar footswitch again to activate bipolar output for between two and five seconds.

- e. Stop activation. Verify that the Coag display changed to 30.  
If the display did not change as described, call the Covidien Service Center.
- 4. To check the Standard mode, press the Standard button and repeat step 3.
- 5. To check the Macro mode, press the Macro button and repeat step 3.
- 6. Disconnect the test cables and remove the 30  $\Omega$  resistor.

### Checking Monopolar Cut Output

1. Connect the test equipment for monopolar output.
  - a. Connect one test cable to the left jack in the Monopolar 1/CEM Instrument receptacle. Pass the test cable through the current transformer and connect the current transformer to the voltmeter.
  - b. Use a test cable to short the two pins on the Patient Return Electrode receptacle.
  - c. Connect the second test cable from the voltmeter to *both* pins of the Patient Return Electrode receptacle.
  - d. Connect the 100  $\Omega$  resistor to the test cables.
  - e. Connect a monopolar footswitch to the Monopolar 1 Footswitch receptacle on the rear panel.
2. Press the Low button.
3. Check the ECON for the selected cut mode.
  - a. Verify that the Coag display shows 30.
  - b. Press the footswitch cut pedal to activate monopolar output for between two and five seconds.
  - c. Stop activation. Verify that the Coag display changed to 300.
  - d. Press the cut pedal again to activate monopolar output for between two and five seconds.
  - e. Stop activation. Verify that the Coag display changed to 30.  
If the display did not change as described, call the Covidien Service Center.
4. To check the Pure mode, press the Pure button and repeat step 3 (above).
5. Check the Blend mode.
  - a. Press the Blend button. The Coag display changes to 20.
  - b. Press the cut pedal to activate monopolar output for between two and five seconds.
  - c. Stop activation. Verify that the Coag display changed to 200.
  - d. Press the cut pedal again to activate monopolar output for between two and five seconds.

- e. Stop activation. Verify that the Coag display changed to 20.  
If the display did not change as described, call the Covidien Service Center.
- 6. Remove the 100  $\Omega$  resistor from the test cables.

## Checking Monopolar Coag Output

1. Connect the test equipment for monopolar output.
  - a. Connect one test cable to the left jack in the Monopolar 1/CEM Instrument receptacle. Pass the test cable through the current transformer and connect the current transformer to the voltmeter.
  - b. Use a test cable to short the two pins on the Patient Return Electrode receptacle.
  - c. Connect the second test cable from the voltmeter to *both* pins of the Patient Return Electrode receptacle.
  - d. Verify that the monopolar footswitch is connected to the Monopolar 1 Footswitch receptacle on the rear panel.
  - e. Connect the 500  $\Omega$  resistor across the output jacks at the end of the test cables.
2. Press the Desiccate button.
3. Check the ECON for the selected coag mode.
  - a. Verify that "10" appears in the Coag display.
  - b. Press the footswitch coag pedal and, while activating the generator, press the Coag up ( $\Delta$ ) or down ( $\nabla$ ) arrow buttons until the voltmeter reading is equivalent to  $141 \pm 9$  mA<sub>rms</sub>. Ignore changes to the Coag display.
  - c. Stop activation. Verify that the Coag display changed to 120.
  - d. Press the coag pedal again and, while activating the generator, press the Coag up ( $\Delta$ ) or down ( $\nabla$ ) arrow buttons until the voltmeter reading is equivalent to  $489 \pm 5$  mA<sub>rms</sub>. Ignore changes to the Coag display.
  - e. Stop activation. Verify that the Coag display changed to 10.
4. To check the Fulgurate mode, press the Fulgurate button and repeat step 3 (above).
  - a. If a "0" (zero) appears in the Cut display and a "10" appears in the coag display, repeat step 3. This completes LCF Fulgurate mode calibration.
  - b. Press the Med (Fulgurate) button. Verify that an "H" appears in the Cut display and a "10" appears in the coag display. Repeat step 3. This completes Fulgurate mode calibration.
5. To check the Spray mode, press the Spray button.
  - a. Verify that "C10" appears in the Coag display.
  - b. Press the coag pedal and, while activating the generator, press the Coag up ( $\Delta$ ) or down ( $\nabla$ ) arrow buttons until the voltmeter reading is equivalent to  $141 \pm 13$  mA<sub>rms</sub>. Ignore changes to the Coag display.

- c.** Stop activation. Verify that the Coag display changed to 120.
  - d.** Press the coag pedal again and, while activating the generator, press the Coag up ( $\Delta$ ) or down ( $\nabla$ ) arrow buttons until the voltmeter reading is equivalent to  $489 \pm 6 \text{ mA}_{\text{rms}}$ . Ignore changes to the Coag display.
  - e.** Stop activation. Verify that the Coag display changed to 10.
- 6.** To save the ECON calibration values, press the Bipolar up arrow ( $\Delta$ ) button.

To leave Calibration mode, refer to *Exiting Calibration Mode* on page 5-28.

## Using the RS-232 Serial Port

The RS-232 serial port allows communication between an attached computer or terminal and the main microcontroller of the generator. This communication link lets you obtain information regarding calibration values, power and mode settings, and the alarm number history of the generator. You can also use the link when calibrating the generator.

### Equipment required

- Phillips screwdriver

## Establish the Communications Link

1. Turn off the generator.
2. On the rear panel of the generator, remove the screws that secure the metal plate that covers the serial port.
3. Connect a standard DB 9 serial cable to your computer and to the serial port.
  - Pin 2 is the serial output data line.
  - Pin 3 is the serial data input line.
  - Pin 5 is the reference line.
4. On your computer, enter your communication program. Configure your computer for 9600 baud, 8 data bits, 1 stop bit, and no parity.
5. Turn on the generator. Information similar to the following is displayed on your computer:

**FX Main**

**(c) 1995 Valleylab**

**Gen Model: Force FX**

**Main F/W Version: #**

**Feedback F/W Version: #**

**REM Impedance = Z**

where # is the version number of the software for the listed microcontrollers. Z is a numeric representation of the REM impedance.

One of the following messages appears (with the Keying ENABLED message) when you activate the generator:

BIPOLAR\_REQ

MONO1\_CUT

MONO1\_COAG

MONO2\_CUT

MONO2\_COAG

keying ENABLED

When activation ceases, the following message appears:

key request removed

## Enter the Commands

You can enter commands to change settings or display data about the generator. Each command should begin with a colon (:) and end with Enter. The # symbol represents a numeric value that you enter with specific commands as noted.

## Data Displays

Some commands result in the display of data for each mode, including CEM. The display format is as follows:

Bipolar Precise	Bipolar Standard	Bipolar Macro	Default Fulgurate
Cut Low	Cut Pure	Cut Blend	Cut CEM
Coag Desiccate	LCF Fulgurate	Coag Spray	Coag CEM

In data displays, numbers represent the Force FX Electrosurgical Generator C modes. You also use these numbers when you enter commands to select a specific mode.

### Bipolar Modes

- 0 Precise
- 1 Standard
- 2 Macro

### Cut Modes

- 0 Low
- 1 Pure
- 2 Blend

### Coag Modes

- 0 Desiccate
- 1 Fulgurate
- 2 Spray

## Commands for Selecting Modes and Power Settings

Command	Action
:FBM#	Specify the bipolar mode (for #, enter the number for the desired mode): 0 = Precise 1 = Standard 2 = Macro
:FBP#	Specify the bipolar power setting (# = 1, 2, 3, ... 65, 70).
:FBU	Increment the bipolar power setting to the next higher value.
:FBD	Decrement the bipolar power setting to the next lower value.
:FTM#	Specify the cut mode (for #, enter the number for the desired mode): 0 = Low 1 = Pure 2 = Blend
:FTP#	Specify the cut power setting (# = 1, 2, 3, ... 290, 300).
:FTU	Increment the cut power setting to the next higher value.
:FTD	Decrement the cut power setting to the next lower value.
:FGM#	Specify the coag mode (for #, enter the number for the desired mode): 0 = Desiccate 1 = Fulgurate 2 = Spray
:FGP#	Specify the coag power setting (# = 1, 2, 3, ... 110, 120).
:FGU	Increment the coag power setting to the next higher value.
:FGD	Decrement the coag power setting to the next lower value.
:FR	Recall the previous front panel settings.

## Commands for Displaying Data on a Computer

Command	Result Displayed on Computer
:PP	Front panel values
:PT	Current real-time clock values
:PSC	Date of last calibration
:PSA	Total time activated in each mode
:PSB	Number of times activated in each mode
:PSK	Number of times output was activated
:PSP	Average power setting used in each mode
:PSF	List of system errors 1 through 10 with time and date stamp
:PSL	List of system errors 11 through 20 with time and date stamp
:PSE#	Number of times specified error has occurred (# represents an alarm number listed in Chapter 6, <i>Troubleshooting</i> )
:PG	Generator model and firmware version numbers

## Commands for Changing the Default Coag Mode

Command	Action
:MC <letter>	where <letter> may be any of the following: D            sets default coag mode to desiccate F            sets default coag mode to fulgurate S            sets default coag mode to spray
:MF <value>	Modifies the selected Fulgurate mode setting, where <value> represents a selection as follows: 0            LCF Fulgurate 1            Fulgurate

No result is displayed unless a character other than D, F, or S is entered. Then the following is displayed:

**No Change  
Try Again!**

To save the new default mode, turn off, then turn on the generator.

## **Disconnect the Computer from the Generator**

1. Turn off the generator.
2. Disconnect the DB 9 cable from the generator.
3. Position the panel over the serial port and install the screws that secure it to the rear panel of the generator.

# Chapter 6

## Troubleshooting

If the generator is not functioning properly, use the information in this section to perform the following tasks:

- Identify and correct the malfunction
- If a system alarm number was displayed, take the appropriate action to correct the alarm condition

## Inspecting the Generator

If the generator malfunctions, check for obvious conditions that may have caused the problem:

- Check the generator for visible signs of physical damage
- Verify that all accessory cords are properly connected
- Check the power cord. Replace the power cord if you find exposed wires, cracks, frayed insulation, or a damaged connector
- Open the fuse drawer and inspect the fuse housing and fuses for damage and corrosion. Verify that the fuses are firmly seated

An internal component malfunction in the generator can damage the fuses. You may need to replace the fuses if the generator fails the self-test or stops functioning. Refer to *Fuse Replacement on page 7-13*.

## Inspecting the Receptacles

### Equipment required

- Bipolar footswitch
- Monopolar footswitch
- Bipolar instrument cords (handswitching and footswitching)
- Monopolar instrument cords (handswitching and footswitching)

1. Turn off the generator.
2. Disconnect the power cord from the wall receptacle.
3. Check the three Footswitch receptacles on the rear panel for obstructions or damage. Check for a secure fit by inserting the bipolar footswitch or monopolar footswitch connector into the appropriate receptacle.

If any connection is loose, replace the Footswitch board assembly. Refer to *Footswitch Board Replacement on page 7-8*.

4. Check the Bipolar Instrument receptacle on the front panel for obstructions or damage. Insert the bipolar instrument connector (footswitching and handswitching) into the appropriate receptacle to verify a secure fit.

If the connection is loose, replace the front panel. Refer to *Front Panel Replacement on page 7-9*.

5. Check the Monopolar 1/CEM and Monopolar 2 Instrument receptacles on the front panel for obstructions or damage. Insert the monopolar instrument connector (footswitching and handswitching) into the appropriate receptacle to verify a secure fit.

If any of the connections are loose, replace the front panel. Refer to *Front Panel Replacement on page 7-9*.

6. Check the Patient Return Electrode receptacle for a broken pin or an obstruction. If the receptacle is damaged or obstructed, replace the REM module. Refer to *Front Panel REM Module Replacement* on page 7-11.

## Inspecting the Internal Components

### Equipment required

- Phillips screwdriver

#### Precaution

The generator contains electrostatic-sensitive components. When repairing the generator, work at a static-control workstation. Wear a grounding strap when handling electrostatic-sensitive components, *except* when working on an energized generator. Handle circuit boards by their nonconductive edges. Use an antistatic container for transport of electrostatic-sensitive components and circuit boards.

1. Remove the five screws that secure the cover to the chassis. Lift the cover off the chassis. Save the cover and screws for reinstallation.
2. Verify that all connectors are firmly seated.
3. Inspect each board for damaged components, wires, cracks, and corrosion.
  - If you find evidence of damage on the Control board, Display board, or Footswitch board, replace the board. Refer to *Control Board Replacement* on page 7-4, *Display Board Replacement* on page 7-5, or *Footswitch Board Replacement* on page 7-8.
  - If you find evidence of damage on the Power Supply/RF board, replace the board only if the damage is severe. Refer to *Power Supply/RF Board Replacement* on page 7-26.
4. To reinstall the cover, position the cover above the chassis and slide it down. Install the five screws that secure the cover to the chassis.

## Correcting Malfunctions

If a solution is not readily apparent, use the table below to help identify and correct specific malfunctions. After you correct the malfunction, verify that the generator completes the self-test as described in Chapter 5, *Setup, Tests, and Adjustment*.

Generator does not respond when turned on	Disconnected power cord, faulty wall receptacle, or faulty power cord	Check power cord connections (generator and wall receptacle). Connect the power cord to a functional wall receptacle. If necessary, replace the power cord.
	Fuse drawer is open or fuses are blown	Close the fuse drawer. If necessary, replace the fuse(s). Refer to <i>Fuse Replacement on page 7-13</i> . If a problem persists, use a backup generator.
	Loose or disconnected internal cables	Check all internal connections.
	Faulty power entry module or connections	Check the power entry module and its cable connections.
	Faulty low voltage power supply	Check the low voltage power supply.
	Damaged Control board connectors and/or malfunctioning Control board	Remove the Control board and inspect the connectors to the Power Supply/RF board and to the Display board for damage, poor seating, etc.  If the problem persists, replace the Control board. For instructions, refer to <i>Control Board Replacement on page 7-4</i> .
	Shorts or disconnects on Power Supply/RF board	Check the Power Supply/RF board for shorts or disconnects.
	Faulty power switch	Replace the power switch. Refer to <i>Front Panel Power Switch Replacement on page 7-12</i> .
	Malfunctioning front panel components	Replace the front panel assembly. Refer to <i>Front Panel Replacement on page 7-9</i> .

**Continued**

Generator is on, but did not complete the self-test	An alarm condition exists	Check the display for an alarm number. Note the number and refer to <i>Responding to System Alarms</i> on page 6-11.
	Software malfunction	Turn off, then turn on the generator.
	Loose or disconnected internal cables	Check and correct all internal connections.
	Faulty low voltage power supply	Check the low voltage power supply.
	Damaged Control board connectors and/or malfunctioning Control board	Remove the Control board and inspect the connectors to the Power Supply/RF board and to the Display board for damage, poor seating, etc. If the problem persists, replace the Control board. For instructions, refer to <i>Control Board Replacement</i> on page 7-4.
	Shorts or disconnects on Power Supply/RF board	Check the Power Supply/RF board for shorts or disconnects.
	Faulty power switch	Replace the power switch. Refer to <i>Front Panel Power Switch Replacement</i> on page 7-12.
Alarm number 212 appears in the Cut display during the self-test	Malfunctioning front panel components	Replace the front panel assembly. Refer to <i>Front Panel Replacement</i> on page 7-9.
	The battery was removed and/or replaced, but the generator was not calibrated	Turn off, then turn on the generator to clear the number. Calibrate the generator. For instructions, refer to <i>Calibrating the Generator</i> on page 5-26.
	Faulty battery on Control board causing loss of battery-backed memory	Replace the battery and check the battery-backed RAM device. Refer to <i>Correcting Battery-Backed RAM Malfunctions</i> on page 6-24.
	Loss of battery-backed RAM due to faulty component on the Control board (other than the battery)	Replace the Control board. Refer to <i>Control Board Replacement</i> on page 7-4.

Continued

Activation and/or alarm tones do not sound; speaker is malfunctioning	Poor connection or damaged Footswitch board ribbon cable	Check/correct connection. If indicated, replace the Footswitch board. Refer to <i>Footswitch Board Replacement</i> on page 7-8.
	Faulty connections or speaker on Footswitch board	Replace the Footswitch board. Refer to <i>Footswitch Board Replacement</i> on page 7-8.
	Audio signal malfunction on Control board	Replace the Control board. Refer to <i>Control Board Replacement</i> on page 7-4.
Blank or confusing LED display	Faulty ribbon cable between Control board and Display board	Check/connect ribbon cable that connects the Display board to the Control board.
	Incorrect display modes communicated through the Control board	Replace the Control board. Refer to <i>Control Board Replacement</i> on page 7-4.
	Display board malfunction	Replace the Display board. Refer to <i>Display Board Replacement</i> on page 7-5.
Mode buttons do not function correctly when pressed	Faulty ribbon cable between Control board and Display board	Check/connect ribbon cable that connects the Display board to the Control board.
	Incorrect modes communicated through the Control board	Replace the Control board. Refer to <i>Control Board Replacement</i> on page 7-4.
	Faulty ribbon cable between the front panel and the Display board	Check/connect the ribbon cable that connects the Display board to the front panel.
	Incorrect modes are being communicated from the front panel	Replace the front panel. Refer to <i>Front Panel Replacement</i> on page 7-9.

**Continued**

Situation	Possible Cause	Recommended Action
Generator is on and accessory is activated, but generator does not deliver output	Malfunctioning footswitch or handswitching instrument	Turn off the generator. Check and correct all accessory connections.  Turn on the generator. Replace the accessory if it continues to malfunction.
	Incompatible footswitch	Use only a Covidien footswitch with the Force FX Electrosurgical Generator C generator.
	Footswitch connected to Monopolar 1 Footswitch receptacle is being used for instrument connected to Monopolar 2 Instrument receptacle	Connect the footswitch to the Monopolar 2 Footswitch receptacle. <i>or</i> Connect the instrument to the Monopolar 1/CEM Instrument receptacle.
	Footswitch connected to Monopolar 2 Footswitch receptacle is being used for instrument connected to Monopolar 1/CEM Instrument receptacle	Connect the footswitch to the Monopolar 1 Footswitch receptacle. <i>or</i> Connect the instrument to the Monopolar 2 Instrument receptacle.
	Power set too low	Increase the power setting.
	An alarm condition exists	Check the Cut display for an alarm number. Note the number and refer to <i>Responding to System Alarms</i> on page 6-11.
	Blown fuse on Power Supply/ RF board	Check the high voltage power supply fuse (F1) and replace if necessary. Refer to <i>Fuse Replacement</i> on page 7-13.
	Control board malfunction	If the indicator bar does not illuminate and the tone does not sound, replace the Control board. Refer to <i>Control Board Replacement</i> on page 7-4.
	High voltage power supply malfunction (high voltage is not present during activation)	If high voltage is not present at TP3 on the Power Supply/RF board, troubleshoot the high voltage power supply.

Continued

Situation	Possible Cause	Recommended Action
<p><b>(Continued)</b> Generator is on and accessory is activated, but generator does not deliver output</p>	<p>RF output stage malfunction (high voltage is present during activation)</p>	<p>Troubleshoot the RF output stage as described below:</p> <p>On the Power Supply/RF board, verify T_ON\ pulses at U4 during activation.</p> <ul style="list-style-type: none"> <li>• If pulses are not present before U4, replace the Control board. Refer to <i>Control Board Replacement</i> on page 7-4.</li> <li>• If pulses are present at U4 but not after U4, replace U4.</li> </ul> <p>Check the power MOSFET at J9 for failure (typically fail shorted).</p> <p>Check all output relays to verify that they are toggling during operation. If they are not, check the relay drivers (U15 and U16).</p> <p>Check for shorting of the output tuning inductors (T14 and T15).</p>
<p>Footswitch will not activate output</p>	<p>Malfunctioning or damaged footswitch receptacle</p>	<p>Replace the Footswitch board. Refer to <i>Footswitch Board Replacement</i> on page 7-8.</p>
	<p>Footswitch activation signal lost on Control board</p>	<p>Replace the Control board. Refer to <i>Control Board Replacement</i> on page 7-4.</p>
<p>Continuous monitor interference</p>	<p>Faulty chassis-to-ground connections</p>	<ul style="list-style-type: none"> <li>• Check and correct the chassis ground connections for the monitor and, if applicable, for the generator.</li> <li>• Check other electrical equipment in the room for defective grounds.</li> </ul>
	<p>Electrical equipment is grounded to different objects rather than a common ground. The generator may respond to the resulting voltage differences between grounded objects.</p>	<p>Plug all electrical equipment into line power at the same location.</p>
	<p>Malfunctioning monitor</p>	<p>Replace the monitor.</p>

**Continued**

Situation	Possible Cause	Recommended Action
Interference with other devices only when generator is activated	Metal-to-metal sparking	Check all connections to the generator, patient return electrode, and accessories.
	High settings used for fulguration	Use lower power settings for fulguration or select the Desiccate mode.
	Electrically inconsistent ground wires in the operating room	Verify that all ground wires are as short as possible and go to the same grounded metal.
	If interference continues when the generator is activated, the monitor is responding to radiated frequencies.	<p>Check with the manufacturer of the monitor.</p> <p>Some manufacturers offer RF choke filters for use in monitor leads. The filters reduce interference when the generator is activated and minimize the potential for an electro-surgical burn at the site of the monitor electrode.</p>
Pacemaker interference	Intermittent connections or metal-to-metal sparking	<p>Check all connections to the generator.</p> <p>It may be necessary to reprogram the pacemaker.</p>
	Current traveling from active to return electrode during monopolar electro-surgery is passing too close to pacemaker.	<p>Use bipolar instruments, if possible. If you must use a monopolar instrument, place the patient return electrode as close as possible to the surgical site. Make sure the current path from the surgical site to the patient return electrode does not pass through the vicinity of the heart or the site where the pacemaker is implanted.</p> <p>Always monitor patients with pacemakers during surgery and keep a defibrillator available.</p> <p>Consult the pacemaker manufacturer or hospital Cardiology Department for further information when use of electro-surgical appliances is planned in patients with cardiac pacemakers.</p>

Continued

Situation	Possible Cause	Recommended Action
Abnormal neuromuscular stimulation ( <i>stop surgery immediately</i> )	Metal-to-metal sparking	Check all connections to the generator, patient return electrode, and active electrodes.
	Can occur during coag	Use a lower power setting for the Fulgurate and Spray modes or select the Desiccate mode.
	Abnormal 50–60 Hz leakage currents	Inside the generator, carefully inspect for damage that may cause shorting between the AC line voltage and connected patient components.

## Responding to System Alarms

When a system alarm condition exists, an alarm tone sounds and a number flashes in the Cut display. The generator is disabled until the condition is cleared.

Most system alarms require some action on your part to correct the condition; however, some are corrected automatically. Use the following table to determine how to correct an alarm condition.

After correcting the alarm condition, verify that the generator completes the self-test as described in Chapter 5, *Setup, Tests, and Adjustment*.

Number	Description	Recommended Action
0	Main microcontroller failed to hold feedback microcontroller in reset	Turn the power switch off (O) then on (I) again. If error reappears, replace the Control board. Refer to <i>Control Board Replacement</i> on page 7-4.
1	Main microcontroller failed to power up feedback microcontroller	
2	Feedback microcontroller failed to power up and initialize RAM in time allotted	Turn the power switch off (O) then on (I) again. If error reappears, replace the Control board. Refer to <i>Control Board Replacement</i> on page 7-4.
3	Feedback microcontroller failed to checksum battery-backed RAM data in dual-port RAM in time allotted	
4	Internal diagnostics Main microcontroller CPU test failed	Replace the Control board. Refer to <i>Control Board Replacement</i> on page 7-4. Calibrate the generator. Refer to <i>Calibrating the Generator</i> on page 5-26. If the alarm number reappears, record the number and call the Covidien Service Center.
5	Main microcontroller unable to access FEEDBACK_SEM semaphore	Turn the power switch off (O) then on (I) again. If error reappears, replace the Control board. Refer to <i>Control Board Replacement</i> on page 7-4.
6	Main microcontroller unable to access ECON_SEM semaphore	
7	Main microcontroller unable to access KEY_ACTIVE_SEM semaphore	

<b>Number</b>	<b>Description</b>	<b>Recommended Action</b>
10	Software malfunction. Invalid alarm number (number shown on terminal using serial port)	Turn off, then turn on the generator. If the alarm number reappears, record the number and call the Covidien Service Center.
11	Internal diagnostics. Invalid activated power, function, mode, or key request mode echoed by feedback microcontroller	Turn the power switch off (O) then on (I) again. If error reappears, replace the Control board. Refer to <i>Control Board Replacement</i> on page 7-4.
12	Diagnostics/microcontroller malfunction. T_ON_ERR test failed	Turn the power switch off (O) then on (I) again. If error reappears, replace the Control board. Refer to <i>Control Board Replacement</i> on page 7-4.
13	Main microcontroller unable to access GEN_SEM semaphore	Turn the power switch off (O) then on (I) again. If error reappears, replace the Control board. Refer to <i>Control Board Replacement</i> on page 7-4.
14	Internal diagnostics. Calibration data checksum error on main microcontroller (data in error shown on terminal using serial port)	Turn the power switch off (O) then on (I) again. If error reappears, replace the Control board. Refer to <i>Control Board Replacement</i> on page 7-4.
16	Diagnostics/microcontroller malfunction. T_ON average test failed	Calibrate the ECON factor. Refer to <i>Calibrating the Generator</i> on page 5-26.  If the alarm number reappears, refer to <i>Correcting T_ON ASIC Malfunctions</i> on page 6-22.
68	Main microcontroller unable to access GEN_SEM semaphore	Turn the power switch off (O) then on (I) again. If error reappears, replace the Control board. Refer to <i>Control Board Replacement</i> on page 7-4.
69	Software malfunction. flash_power_state value outside state range	Turn off, then turn on the generator. If the alarm number reappears, record the number and call the Covidien Service Center.
70	Software malfunction. key_req_mode value outside state range	
71	Software malfunction. request+1 value outside state range	
80	Software malfunction. *input[i].p_state value outside state range	

Number	Description	Recommended Action
81	Internal component malfunction. Optoisolator test failed	Do not attempt to use the generator. Record the number and call the Covidien Service Center.
90	Generator model number in main microcontroller Flash Memory not Force FX	Turn the power switch off (O) then on (I) again. If error reappears, replace the Control board. Refer to <i>Control Board Replacement</i> on page 7-4.
95	Electrosurgical Generator C model number  Generator model number in main microcontroller Flash Memory not Force FX Electrosurgical Generator C model number	
100	Software malfunction. rem_update_state value outside state range	Turn off, then turn on the generator. If the alarm number reappears, record the number and call the Covidien Service Center.
101	Software malfunction. rem_pad_state value outside state range	
102	Software malfunction. rem_state value in re_rem_control() outside state range	
103	Software malfunction. rem_state value in re_non_rem_control() outside state range	
104	Software malfunction. rem_flash_state value outside state range	
105	Software malfunction. rem_led_state value outside state range	
110	Software malfunction. cal_state value in ca_generator_setup() outside state range	
111	Software malfunction. cal_state value in ca_clock_date_setup() outside state range	

Troubleshooting

<b>Number</b>	<b>Description</b>	<b>Recommended Action</b>
112	Software malfunction. cal_mode value in ca_clock_date_setup() outside state range	Turn off, then turn on the generator. If the alarm number reappears, record the number and call the Covidien Service Center.
113	Software malfunction. cal_state value in ca_clock_time_setup() outside state range	
114	Software malfunction. cal_mode value in ca_clock_time_setup() outside state range	
115	Software malfunction. cal_state value in ca_coag_leakage_cal( ) outside state range	
116	Software malfunction. cal_state value in ca_econ_cal( ) outside state range	
117	Software malfunction. econ_cal_state value outside state range	
118	Software malfunction. cal_state value in ca_rem_cal() outside state range	
119	Software malfunction. rem_cal_state value outside state range	
120	Calibration malfunction. Calibration value(s) outside acceptable range	
121	Software malfunction. cal_mode value in ca_generator_setup( ) outside state range	Turn off, then turn on the generator. If the alarm number reappears, record the number and call the Covidien Service Center.
122	Open circuit REM sense failure	Repeat the failing calibration step. If the alarm number reappears, record the number and call the Covidien Service Center.

Number	Description	Recommended Action
123	Main microcontroller unable to access GEN_SEM semaphore	Turn the power switch off (O) then on (I) again. If error reappears, replace the Control board. Refer to <i>Control Board Replacement</i> on page 7-4.
124	Main microcontroller unable to access FEEDBACK_SEM semaphore	
125	Main microcontroller unable to access ECON_SEM semaphore	
126	Main microcontroller unable to access KEY_ACTIVE_SEM semaphore	
151	Main microcontroller unable to access GEN_SEM semaphore	Turn the power switch off (O) then on (I) again. If error reappears, replace the Control board. Refer to <i>Control Board Replacement</i> on page 7-4.
152	Software malfunction. cal_state value in cs_i_sns_cal( ) outside state range	Turn off, then turn on the generator. If the alarm number reappears, record the number and call the Covidien Service Center.
154	Main microcontroller unable to access FEEDBACK_SEM semaphore	Turn the power switch off (O) then on (I) again. If error reappears, replace the Control board. Refer to <i>Control Board Replacement</i> on page 7-4.
160	Internal component malfunction. Dosage error test failed. ADC values display at failure	Calibrate the ECON factor. Refer to <i>Calibrating the Generator</i> on page 5-26. If the alarm number reappears, refer to <i>Correcting T_ON ASIC Malfunctions</i> on page 6-22.
170	Watchdog malfunction. Correct value not sent from feedback microcontroller	Turn the power switch off (O) then on (I) again. If error reappears, replace the Control board. Refer to <i>Control Board Replacement</i> on page 7-4.
171	Watchdog malfunction. Correct value not sent from main microcontroller	Turn the power switch off (O) then on (I) again. If error reappears, replace the Control board. Refer to <i>Control Board Replacement</i> on page 7-4.
172	Watchdog malfunction. Main microcontroller unable to access watchdog semaphore	
173	Watchdog malfunction. Feedback microcontroller unable to access watchdog semaphore	Turn the power switch off (O) then on (I) again. If error reappears, replace the Control board. Refer to <i>Control Board Replacement</i> on page 7-4.

<b>Number</b>	<b>Description</b>	<b>Recommended Action</b>
174	Software malfunction. which_errors value outside state range	Turn off, then turn on the generator. If the alarm number reappears, record the number and call the Covidien Service Center.
180	Internal diagnostics. Main microcontroller ST Microelectronics RAM check failed	Turn the power switch off (O) then on (I) again. If error reappears, replace the Control board. Refer to <i>Control Board Replacement</i> on page 7-4.
181	Internal diagnostics. Feedback microcontroller ST Microelectronics RAM check failed	Turn the power switch off (O) then on (I) again. If error reappears, replace the Control board. Refer to <i>Control Board Replacement</i> on page 7-4.
182	Internal diagnostics. Main microcontroller dual-port RAM check failed	Turn the power switch off (O) then on (I) again. If error reappears, replace the Control board. Refer to <i>Control Board Replacement</i> on page 7-4.
183	Internal diagnostics. Main microcontroller Page 0 (zero) Flash Memory CRC test failed	
184	Internal diagnostics. Main microcontroller Page F Flash Memory CRC test failed	
185	Internal diagnostics. Feedback microcontroller Flash Memory CRC test failed	Turn the power switch off (O) then on (I) again. If error reappears, replace the Control board. Refer to <i>Control Board Replacement</i> on page 7-4.
189	Software malfunction. display_state value outside state range	Turn off, then turn on the generator. If the alarm number reappears, record the number and call the Covidien Service Center.

Number	Description	Recommended Action
190	Internal diagnostics. Bipolar buttons (up arrow, down arrow, Precise, Standard, and/or Macro) may be stuck	1. Turn off, then turn on the generator. Do not press buttons or accessory activation devices during the self-test.
191	Internal diagnostics. Cut buttons (up arrow, down arrow, Low, Pure, and/or Blend) may be stuck (button shown on terminal using serial port)	2. If the alarm number reappears, disconnect all accessories. Turn off, then turn on the generator again.
192	Internal diagnostics. Coag buttons (up arrow, down arrow, Desiccate, Fulgurate, and/or Spray) may be stuck (button shown on terminal using serial port)	If the alarm number reappears, record the number and call the Covidien Service Center.
193	Internal diagnostics. Recall button may be stuck (button shown on terminal using serial port)	
194	Internal diagnostics. Handswitch or Monopolar 1 Footswitch cut pedal may be stuck	
195	Internal diagnostics. Handswitch or Monopolar 1 Footswitch coag pedal may be stuck	
196	Internal diagnostics. Handswitch or Monopolar 2 Footswitch cut pedal may be stuck	
197	Internal diagnostics. Handswitch or Monopolar 2 Footswitch coag pedal may be stuck	
198	Internal diagnostics. Handswitch or Bipolar Footswitch pedal may be stuck	
199	Internal diagnostics. Main and feedback microcontrollers are not compatible	Turn the power switch off (O) then on (I) again. If error reappears, replace the Control board. Refer to <i>Control Board Replacement</i> on page 7-4.

Number	Description	Recommended Action
200	Internal diagnostics. Main microcontroller SEML line may be stuck	<b>1.</b> Replace the Control board. Refer to <i>Control Board Replacement</i> on page 7-4. <b>2.</b> <i>Calibrate the generator. Refer to Calibrating the Generator</i> on page 5-26.  If the alarm number reappears, record the number and call the Covidien Service Center.
201	Internal diagnostics. Feedback microcontroller SEMR line may be stuck	
202	Internal diagnostics. Main microcontroller watchdog test failed	Turn the power switch off (O) then on (I) again. If error reappears, replace the Control board. Refer to <i>Control Board Replacement</i> on page 7-4.
203	Internal diagnostics. Feedback microcontroller watchdog test failed	Turn the power switch off (O) then on (I) again. If error reappears, replace the Control board. Refer to <i>Control Board Replacement</i> on page 7-4.
206	Software malfunction. doserr_test_state value in st_m_doserr_test outside state range	Turn off, then turn on the generator. If the alarm number reappears, record the number and call the Covidien Service Center.
207	Software malfunction. doserr_test_state value in st_fb_doserr_test outside state range	
208	Main microcontroller timer interrupt failed	<b>1.</b> Replace the Control board. Refer to <i>Control Board Replacement</i> on page 7-4. <b>2.</b> <i>Calibrate the generator. Refer to Calibrating the Generator</i> on page 5-26.  If the alarm number reappears, record the number and call the Covidien Service Center.
209	Feedback microcontroller timer interrupt failed	
210	Software malfunction. data_type value outside state range	Turn off, then turn on the generator. If the alarm number reappears, record the number and call the Covidien Service Center
211	Software malfunction. which_data value outside state range	
212	Generator not calibrated	Refer to <i>Calibrating the Generator</i> on page 5-26.
213	Internal diagnostics. Firmware not compatible with hardware	Turn the power switch off (O) then on (I) again. If error reappears, replace the Control board. Refer to <i>Control Board Replacement</i> on page 7-4.

Number	Description	Recommended Action
215	Internal diagnostics. Real-time clock chip (U1) not compatible with firmware	<ol style="list-style-type: none"> <li>1. Replace the Control board. Refer to <i>Control Board Replacement</i> on page 7-4.</li> <li>2. Calibrate the generator. Refer to <i>Calibrating the Generator</i> on page 5-26.</li> </ol> <p>If the alarm number reappears, record the number and call the Covidien Service Center.</p>
216	Internal memory battery exhausted	<ol style="list-style-type: none"> <li>1. Replace the battery. Refer to <i>Battery Replacement</i> on page 7-3.</li> <li>2. Calibrate the generator. Refer to <i>Calibrating the Generator</i> on page 5-26.</li> </ol> <p>If the alarm number reappears, record the number and call the Covidien Service Center.</p>
220 221	Feedback microcontroller unable to access KEY_REQ_SEM semaphore  Feedback microcontroller unable to access GEN_SEM semaphore	Turn the power switch off (O) then on (I) again. If error reappears, replace the Control board. Refer to <i>Control Board Replacement</i> on page 7-4.
222 223	Main microcontroller failed to copy battery-backed RAM data to dual-port RAM in time allotted  Main microcontroller failed to complete initialization in time allotted	Turn the power switch off (O) then on (I) again. If error reappears, replace the Control board. Refer to <i>Control Board Replacement</i> on page 7-4.
224	Internal diagnostics. Calibration data checksum error on feedback microcontroller (data in error shown on terminal using serial port)	Turn the power switch off (O) then on (I) again. If error reappears, replace the Control board. Refer to <i>Control Board Replacement</i> on page 7-4.
225	Internal diagnostics. Feedback microcontroller CPU test failed	<ol style="list-style-type: none"> <li>1. Replace the Control board. Refer to <i>Control Board Replacement</i> on page 7-4.</li> <li>2. Calibrate the generator. Refer to <i>Calibrating the Generator</i> on page 5-26.</li> </ol> <p>If the alarm number reappears, record the number and call the Covidien Service Center.</p>

Number	Description	Recommended Action
226	Feedback microcontroller unable to access FEEDBACK_SEM semaphore	Turn the power switch off (O) then on (I) again. If error reappears, replace the Control board. Refer to <i>Control Board Replacement</i> on page 7-4.
230	Software malfunction. keyed_state value outside state range	Turn off, then turn on the generator. If the alarm number reappears, record the number and call the Covidien Service Center.
231	Software malfunction. key_req_mode value outside state range	
232	Feedback microcontroller unable to access KEY_ACTIVE_SEM semaphore	Turn the power switch off (O) then on (I) again. If error reappears, replace the Control board. Refer to <i>Control Board Replacement</i> on page 7-4.
240	Software malfunction. activation_seq value outside state range	Turn off, then turn on the generator. If the alarm number reappears, record the number and call the Covidien Service Center.
241	Software malfunction. feedback value in do_feedback( ) outside state range	
242	Software malfunction. feedback value in do_cal_feedback( ) outside state range	
244	Software malfunction. disable_seq value outside state range	
245	Software malfunction. spark_state value outside state range	
246	Feedback microcontroller unable to access FEEDBACK_SEM semaphore	
247	Feedback microcontroller unable to access ECON_SEM semaphore	

Number	Description	Recommended Action
260	Internal diagnostics. A/D conversion did not complete in allowed time	<ol style="list-style-type: none"> <li>1. Replace the Control board. Refer to <i>Control Board Replacement</i> on page 7-4.</li> <li>2. Calibrate the generator. Refer to <i>Calibrating the Generator</i> on page 5-26.</li> </ol> <p>If the alarm number reappears, record the number and call the Covidien Service Center.</p>
261	Software malfunction. Delay time out of bounds on main microcontrollers	Turn off, then turn on the generator. If the alarm number reappears, record the number and call the Covidien Service Center.
262	Software malfunction. Delay time out of bounds on feedback microcontroller	
270	Software malfunction. Data type in me_rtc_get_() outside of the state range	
271	Software malfunction. Data type in me_rtc_put_() outside of the state range	
451	The internal temperature limit was exceeded due to length of activation time.	<p>Verify that the location of the generator allows for adequate cooling.</p> <p>Use the lowest power setting that achieves the desired effect. Limit activation times, if possible.</p>

## Correcting T\_ON ASIC Malfunctions

### Equipment required

- Phillips screwdriver
- Surface mount, quad pack chip extractor

### Warning

**Electric Shock Hazard** To allow stored energy to dissipate after power is disconnected, wait at least five minutes before replacing parts.

**Electric Shock Hazard** Do not touch any exposed wiring or conductive surfaces while the generator is disassembled and energized. Never wear a grounding strap when working on an energized generator.

### Precaution

The generator contains electrostatic-sensitive components. When repairing the generator, work at a static-control workstation. Wear a grounding strap when handling electrostatic-sensitive components, except when working on an energized generator. Handle circuit boards by their nonconductive edges. Use an antistatic container for transport of electrostatic-sensitive components and circuit boards.

### Important

If you are responding to a specific alarm number, first calibrate the ECON factor as described in *Checking and Adjusting the ECON Factor* on page 5-38. If the alarm number reappears after calibration, complete this procedure.

1. Turn off the generator. Disconnect the power cord from the wall receptacle.
2. Remove the five screws that secure the cover to the chassis. Lift the cover off the chassis.
3. Remove the Control board.
  - a. Unlock the connector on the Control board and disconnect the Display board ribbon cable from the Control board.
  - b. Carefully slide the Control board straight up through the slots in the heat sinks to disconnect it from the Power Supply/RF board.
4. Replace the Control board.
  - a. Turn off the generator. Disconnect the power cord from the wall receptacle.
  - b. Remove the Control board (refer to step 3 on page 6-22).
  - c. Install the new Control board. Position the Control board over the Power Supply/RF board with the components facing the rear panel. Fit the edges of the board into the slots on the heat sinks. Slide the board down, carefully fitting the connector into the matching connector on the Power Supply/RF board.

- d. Connect the Display board ribbon cable to the Control board and lock the connector.
5. Calibrate the generator. Refer to *Calibrating the Generator* on page 5-26 for instructions.  
If the alarm number reappears, record the number and call the Covidien Service Center.
6. To install the cover, position the cover above the chassis and slide it down. Install the five screws that secure the cover to the chassis.

## Correcting Battery-Backed RAM Malfunctions

### Equipment required

- Phillips screwdriver
- Surface mount, quad pack chip extractor

### Warning

**Electric Shock Hazard** To allow stored energy to dissipate after power is disconnected, wait at least five minutes before replacing parts.

**Electric Shock Hazard** Do not touch any exposed wiring or conductive surfaces while the generator is disassembled and energized. Never wear a grounding strap when working on an energized generator.

### Precaution

The generator contains electrostatic-sensitive components. When repairing the generator, work at a static-control workstation. Wear a grounding strap when handling electrostatic-sensitive components, except when working on an energized generator. Handle circuit boards by their nonconductive edges. Use an antistatic container for transport of electrostatic-sensitive components and circuit boards.

### Notice

Calibrate the generator after you install a new battery. Calibration values are lost when the battery is replaced. Refer to *Calibrating the Generator* on page 5-26, for instructions.

1. Turn off the generator. Disconnect the power cord from the wall receptacle.
2. Remove the five screws that secure the cover to the chassis. Lift the cover off the chassis.
3. Remove the Control board.
  - a. Unlock the connector on the Control board and disconnect the Display board ribbon cable from the Control board.
  - b. Carefully slide the Control board straight up through the slots in the heat sinks to disconnect it from the Power Supply/RF board.

### Important

All data stored in internal memory (refer to *Internal Memory Audio Volume* on page 3-4) is lost when the battery is removed.

4. Replace the battery.
  - a. Grasp the battery and slide it up and out of the socket.
  - b. Position the new 3 V button-cell battery above the socket so that the positive side of the battery is facing out (visible).
  - c. Slide the new battery down into the socket.

5. Install the Control board.
  - a. Position the Control board over the Power Supply/RF board with the components facing the rear panel. Fit the edges of the board into the slots on the heat sinks. Slide the board down, carefully fitting the edge connector into the matching connector on the Power Supply/RF board.
  - b. Connect the Display board ribbon cable to the Control board and lock the connector.
6. Calibrate the generator. Refer to *Calibrating the Generator* on page 5-26, for instructions. If the calibration is successful, install the cover (refer to step 9).
7. If the alarm number reappears, replace the Control board.
  - a. Turn off the generator.
  - b. Remove the Control board (refer to step 3).
  - c. Install the new Control board (refer to step 6).
8. Recalibrate the generator. If the alarm number reappears, record the number and call the Covidien Service Center.
9. To install the cover, position the cover above the chassis and slide it down. Install the five screws that secure the cover to the chassis.



# Chapter 7

## Replacement Procedures

Follow the procedures in this section when you need to replace the parts listed below:

- Battery for battery-backed RAM
- Control board
- Display board and seven-segment LEDs
- Fan
- Footswitch board
- Front panel
- Front panel components, including the REM module and power switch
- Fuses, including two in the fuse drawer and one on the Power Supply/RF board
- Heat sinks (left front, left rear, and right heat sinks) and associated heat sink components
- Low voltage power supply
- Power entry module
- Power Supply/RF board.

For your reference, this section also includes an electrical cable interconnect diagram that illustrates all cable connections.

The parts used in these procedures are illustrated in Chapter 9, *Service Parts*.

# Interconnect Diagram

*A block diagram of generator interconnections*

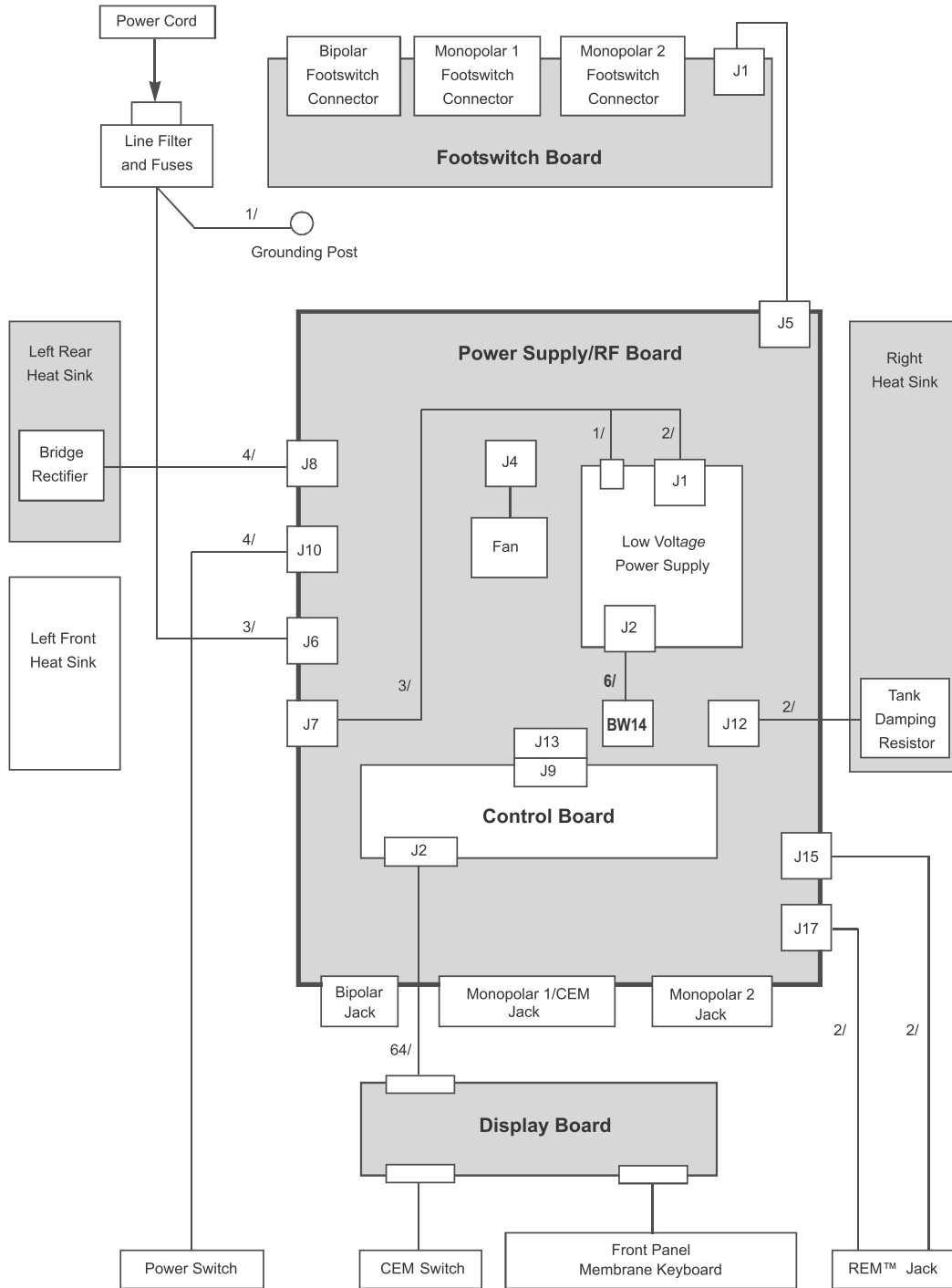

## Battery Replacement

### Equipment required

- Phillips screwdriver

#### Warning

**Electric Shock Hazard** To allow stored energy to dissipate after power is disconnected, wait at least five minutes before replacing parts.

#### Precaution

The generator contains electrostatic-sensitive components. When repairing the generator, work at a static-control workstation. Wear a grounding strap when handling electrostatic-sensitive components, except when working on an energized generator. Handle circuit boards by their nonconductive edges. Use an antistatic container for transport of electrostatic-sensitive components and circuit boards.

#### Notice

Calibrate the generator after you install a new battery. Calibration values are lost when the battery is replaced. Refer to *Calibrating the Generator* on page 5-26, for instructions.

#### Important

All data stored in internal memory (refer to *Internal Memory Audio Volume* on page 3-4) is lost when the battery is removed.

1. Turn off the generator. Disconnect the power cord from the wall receptacle.
2. Remove the five screws that secure the cover to the chassis. Lift the cover off the chassis. Set the cover and screws aside for reinstallation.
3. Locate the battery at the upper left corner of the Control board.
4. Grasp the battery and slide it up and out of the socket.
5. Install the new 3 V button-cell battery (CR2450 or equivalent).
  - a. Position the battery above the socket so that the positive side of the battery is facing out (visible).
  - b. Slide the battery down into the socket until it is firmly seated.
6. Position the cover above the chassis and slide it down. Install the five screws that secure the cover to the chassis.

## Control Board Replacement

### Equipment required

- Phillips screwdriver

### Warning

**Electric Shock Hazard** To allow stored energy to dissipate after power is disconnected, wait at least five minutes before replacing parts.

### Precaution

The generator contains electrostatic-sensitive components. When repairing the generator, work at a static-control workstation. Wear a grounding strap when handling electrostatic-sensitive components, except when working on an energized generator. Handle circuit boards by their nonconductive edges. Use an antistatic container for transport of electrostatic-sensitive components and circuit boards.

### Notice

Calibrate the generator after you install a new Control board. Otherwise, the default calibration values are used. Refer to *Calibrating the Generator* on page 5-26, for instructions.

1. Turn off the generator. Disconnect the power cord from the wall receptacle.
2. Remove the five screws that secure the cover to the chassis. Lift the cover off the chassis. Set the cover and screws aside for reinstallation.
3. Unlock the connector on the Control board and disconnect the Display board ribbon cable from the Control board.
4. Carefully slide the Control board straight up through the slots on the heat sinks to disconnect it from the Power Supply/RF board.
5. Verify that the packaging for the new Control board contains the part number for the Force FX Electrosurgical Generator C Control board. Do not install any other Control board.
6. Install the battery in the battery socket (positive side facing up).
7. Position the new Control board over the Power Supply/RF board with the Control board components facing the rear panel. Fit the edges of the board into the slots on the heat sinks. Slide the board down, carefully fitting the edge connector into the matching connector on the Power Supply/RF board.
8. Connect the Display board ribbon cable to the Control board and lock the connector.
9. Position the cover above the chassis and slide it down. Install the five screws that secure the cover to the chassis.

# Display Board Replacement

## Equipment required

- Phillips screwdriver

## Remove the Display Board

### Warning

**Electric Shock Hazard** To allow stored energy to dissipate after power is disconnected, wait at least five minutes before replacing parts.

### Precaution

The generator contains electrostatic-sensitive components. When repairing the generator, work at a static-control workstation. Wear a grounding strap when handling electrostatic-sensitive components, except when working on an energized generator. Handle circuit boards by their nonconductive edges. Use an antistatic container for transport of electrostatic-sensitive components and circuit boards.

1. Turn off the generator. Disconnect the power cord from the wall receptacle.
2. Remove the five screws that secure the cover to the chassis. Lift the cover off the chassis. Set the cover and screws aside for reinstallation.
3. Remove the Control board.
  - a. Unlock the connector on the Control board and disconnect the Display board ribbon cable from the Control board.
  - b. Carefully slide the Control board straight up through the slots on the heat sinks to disconnect it from the Power Supply/RF board. Set the board aside in an antistatic container for reinstallation.
4. Disconnect and remove the front panel assembly.
  - a. Disconnect the power switch from the Power Supply/RF board.
  - b. Disconnect the two REM connectors from the Power Supply/RF board.
  - c. Remove the four screws that secure the front panel to the chassis. Save the screws for reinstallation.
  - d. Slide the front panel assembly forward, carefully disengaging it from the electrical contacts on the Power Supply/RF board.
5. Detach and disconnect the Display board from the front panel.
  - a. Remove the four screws that secure the Display board to the front panel. Save the screws for reinstallation.
  - b. Disconnect the CEM switch cable from the Display board.
  - c. Disconnect the membrane keyboard ribbon cable from the Display board.

- d. Disconnect the grounding clips from each side of the bezel by sliding the clips away from the bezel until they are loose and held only by the Display board.

## Install the Display Board

1. Connect and attach the Display board to the front panel.
  - a. Connect the membrane keyboard ribbon cable to the Display board.
  - b. Connect the CEM switch cable to the Display board.
  - c. Connect the grounding clips to each side of the bezel by sliding the clips toward the bezel until they are snug.
  - d. Position the Display board over the front panel posts and install the four screws that secure the board to the front panel.
2. Install the front panel assembly.
  - a. Position the front panel assembly in front of the chassis and carefully slide it into the electrical contacts on the Power Supply/RF board.
  - b. Install the four screws that secure the front panel to the chassis.
  - c. Connect the power switch cable to J10 on the Power Supply/RF board.
3. Connect the REM wires to the Power Supply/RF board.
  - a. Connect the white wires with the 2-pin nonlocking connector to J15.
  - b. Connect the red wires with the 2-pin locking connector to J17.
4. Install the Control board.
  - a. Position the Control board over the Power Supply/RF board with the Control board components facing the rear panel. Fit the edges of the board into the slots on the heat sinks. Slide the board down, carefully fitting the edge connector into the matching connector on the Power Supply/RF board.
  - b. Connect the Display board ribbon cable to the Control board and lock the connector.
5. Position the cover above the chassis and slide it down. Install the five screws that secure the cover to the chassis.

## Display Board Seven-Segment LED Replacement

1. Remove the Display board (observe all warnings and cautions). Refer to *Display Board Replacement* on page 7-5.
2. Grasp the seven-segment LED and pull it out of the Display board, taking care not to bend the pins. Note the orientation of pin 1 (the corner with the small 45° chamfer).
3. Verify that the replacement LED is the correct color (green).
4. Install the new seven-segment LED, making sure that the orientation of pin 1 (designated by the small 45° chamfer) is the same as that of the LED you removed.
5. Reinstall the Display board. Refer to *Display Board Replacement* on page 7-5.

## Fan Replacement

1. Remove the Power Supply/RF board and attached heat sinks (observe all warnings and cautions). Refer to *Power Supply/RF Board Replacement* on page 7-26.
2. Disconnect the fan connector from the Power Supply/RF board.
3. Turn the Power Supply/RF board over, and remove the four screws and nuts that secure the fan to the board.
4. Position the new fan on top of the Power Supply/RF board and install the four nuts and screws that secure it to the board.
5. Connect the fan connector to J4 on the Power Supply/RF board.
6. Reinstall the Power Supply/RF board and attached heat sinks. Refer to *Power Supply/RF Board Replacement* on page 7-26.

## Footswitch Board Replacement

1. Remove the Power Supply/RF board and attached heat sinks (observe all warnings and cautions). Refer to *Power Supply/RF Board Replacement* on page 7-26.
2. Remove the Footswitch board assembly.
  - a. On the rear panel, remove the six screws that secure the footswitch receptacles to the rear panel.
  - b. Inside the rear panel, remove the three screws that secure the Footswitch board assembly to the rear panel standoffs.
3. Install the new Footswitch board assembly.
  - a. Position the assembly inside the rear panel and install the three screws that secure the assembly to the rear panel.
  - b. On the rear panel, install the six screws that secure the footswitch receptacles to the rear panel.
4. Reinstall the Power Supply/RF board and attached heat sinks. Refer to *Power Supply/RF Board Replacement* on page 7-26.

## Front Panel Replacement

### Equipment required

- Phillips screwdriver

### Warning

**Electric Shock Hazard** To allow stored energy to dissipate after power is disconnected, wait at least five minutes before replacing parts.

### Precaution

The generator contains electrostatic-sensitive components. When repairing the generator, work at a static-control workstation. Wear a grounding strap when handling electrostatic-sensitive components, except when working on an energized generator. Handle circuit boards by their nonconductive edges. Use an antistatic container for transport of electrostatic-sensitive components and circuit boards.

## Remove the Front Panel Assembly

1. Turn off the generator. Disconnect the power cord from the wall receptacle.
2. Remove the five screws that secure the cover to the chassis. Lift the cover off the chassis. Set the cover and screws aside for reinstallation.
3. Unlock the connector on the Control board and disconnect the Display board ribbon cable from the Control board.
4. Disconnect the power switch cable from the Power Supply/RF board.
5. Disconnect the two REM connectors from the Power Supply/RF board.
6. Remove the four screws that secure the front panel to the chassis. Save the screws for reinstallation.
7. Slide the front panel assembly forward, carefully disengaging it from the electrical contacts on the Power Supply/RF board.

## Remove and Reinstall the Front Panel Components

If you are replacing the entire front panel assembly, go to *Install the Front Panel Assembly* on page 7-10.

or

If you are replacing only the front panel, follow these instructions to remove the components (Display board, REM module, and power switch) and install them on the new front panel.

1. Detach and disconnect the Display board from the front panel.
  - a. Remove the four screws that secure the Display board to the front panel. Save the screws for reinstallation.
  - b. Disconnect the CEM switch cable from the Display board.

- c. Disconnect the membrane display ribbon cable from the Display board.
    - d. Disconnect the grounding clips from each side of the bezel by sliding the clips away from the bezel until they are loose and held only by the Display board.
  2. Remove the REM module and reinstall it on the new front panel.
    - a. Remove the two screws that secure the REM module to the front panel. Then, remove the bracket that covers the REM module and remove the REM module.
    - b. From inside the new front panel, insert the REM module into the front panel opening.
    - c. Place the bracket over the REM module and install the two screws that secure the module to the new front panel.
  3. Remove the power switch and reinstall it on the new front panel.
    - a. Inside the front panel, press the four tabs that secure the power switch and push the switch (and connected cable) out the opening.
    - b. Outside the new front panel, route the power switch cable through the power switch opening.
    - c. Position the power switch with the On (I) switch above the Off (O) switch. Press to snap the switch into place.
  4. Install the Display board on the new front panel.
    - a. Connect the membrane keyboard ribbon cable to the Display board.
    - b. Connect the CEM switch cable to the Display board.
    - c. Connect the grounding clips to each side of the bezel by sliding the clips toward the bezel until they are snug.
    - d. Position the Display board over the front panel posts and install the four screws that secure the board to the front panel.

## Install the Front Panel Assembly

1. Position the front panel assembly in front of the chassis and carefully slide it into the electrical contacts on the Power Supply/RF board.
2. Install the four screws that secure the front panel to the chassis.
3. Connect the REM wires to the Power Supply/RF board.
  - a. Connect the white wires with the 2-pin nonlocking connector to J15.
  - b. Connect the red wires with the 2-pin locking connector to J17.
4. Connect the power switch cable to J10 on the Power Supply/RF board.
5. Connect the Display board ribbon cable to the Control board and lock the connector.
6. Position the cover above the chassis and slide it down. Install the five screws that secure the cover to the chassis.

## Front Panel REM Module Replacement

1. Remove the front panel assembly (observe all warnings and cautions). Refer to *Front Panel Replacement* on page 7-9.
2. Remove the two screws that secure the REM module to the front panel and remove the bracket that covers the REM module. Set the bracket and screws aside for reinstallation.
3. Replace the existing module with a new REM module.
4. Position the bracket over the new REM module and install the two screws that secure the module to the front panel.
5. Reinstall the front panel assembly. Refer to *Front Panel Replacement* on page 7-9.

## Front Panel Power Switch Replacement

1. Remove the front panel assembly (observe all warnings and cautions). Refer to *Front Panel Replacement* on page 7-9.
2. Inside the front panel, press the four tabs that secure the power switch and push the switch (and connected cable) out the opening.

### **Removing and disconnecting the power switch**

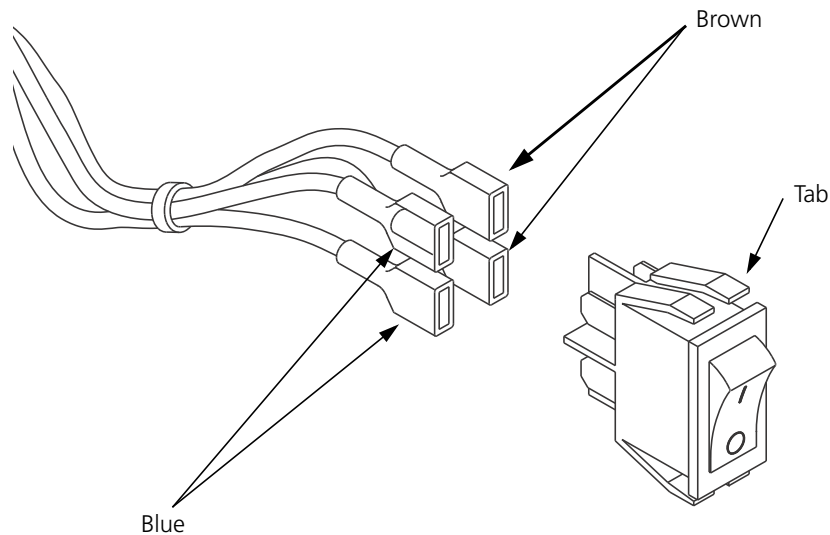

3. Remove the heat shrink from the cables and old switch.
4. Slide a piece of heat shrink tubing (1.0" [2.54 cm] wide; 2.5" [6.35 cm] long) over the wires.
5. Connect the cable to the new power switch assembly, using the illustration or the assembly you just removed as a reference.
6. Using a heat gun, shrink the tubing around the electrical connectors on the switch. Do not allow the heat shrink tubing to cover the plastic tabs on the switch.
7. Outside the front panel, route the power switch cable through the power switch opening.
8. Position the power switch with the On (I) switch above the Off (O) switch. Press to snap the switch into place.
9. Reinstall the front panel assembly. Refer to *Front Panel Replacement* on page 7-9.

## Fuse Replacement

### Replacing Fuses in the Fuse Drawer

#### Equipment required

- Small flathead screwdriver
- Fuse puller

#### Warning

**Fire Hazard** For continued protection against fire hazard, replace fuses only with fuses of the same type and rating as the original fuse.

1. Turn off the generator. Disconnect the power cord from the wall receptacle. Disconnect the power cord from the rear panel for easier access to the adjacent fuse drawer.
2. To release the fuse drawer, insert a small flathead screwdriver into the slot on the drawer below the power cord receptacle. Then, slide the drawer out.

#### Replacing fuses in the fuse drawer

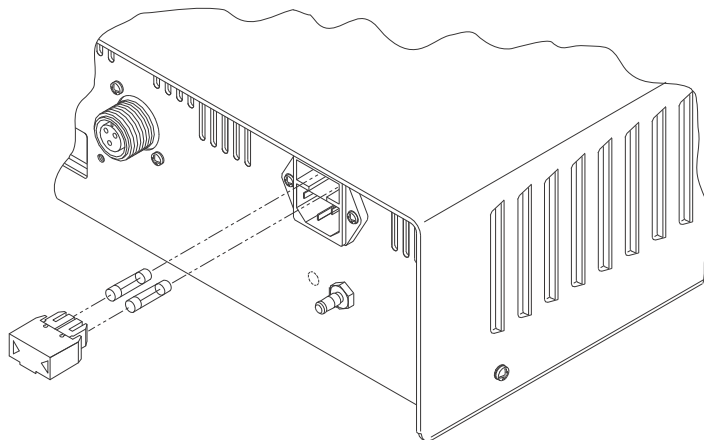

3. Use a fuse puller to remove each blown fuse from the fuse drawer.
4. Replace each blown fuse with one of the same type and rating:
  - For 120 V operation, use 8-amp fuses.
  - For 240 V operation, use 4-amp fuses.
5. Slide the fuse drawer into its slot until it snaps into place.
6. Connect the power cord to the rear panel.

## Replacing the Fuse on the Power Supply/RF Board

### Equipment required

- Phillips screwdriver
- Fuse puller

### Warning

**Fire Hazard** For continued protection against fire hazard, replace fuses only with fuses of the same type and rating as the original fuse.

**Electric Shock Hazard** To allow stored energy to dissipate after power is disconnected, wait at least five minutes before replacing parts.

### Precaution

The generator contains electrostatic-sensitive components. When repairing the generator, work at a static-control workstation. Wear a grounding strap when handling electrostatic-sensitive components, except when working on an energized generator. Handle circuit boards by their nonconductive edges. Use an antistatic container for transport of electrostatic-sensitive components and circuit boards.

1. Turn off the generator. Disconnect the power cord from the wall receptacle.
2. Remove the five screws that secure the cover to the chassis. Lift the cover off the chassis. Set the cover and screws aside for reinstallation.
3. Locate the fuse at the rear of the Power Supply/RF board, near the power entry module. Use a fuse puller to remove the blown fuse.
4. Replace the blown fuse with a 6.3-amp fuse.
5. Position the cover above the chassis and slide it down. Install the five screws that secure the cover to the chassis.

## Left Front Heat Sink and Component Replacement

### Equipment required

- Phillips screwdriver

### Warning

**Electric Shock Hazard** To allow stored energy to dissipate after power is disconnected, wait at least five minutes before replacing parts.

### Precaution

The generator contains electrostatic-sensitive components. When repairing the generator, work at a static-control workstation. Wear a grounding strap when handling electrostatic-sensitive components, except when working on an energized generator. Handle circuit boards by their nonconductive edges. Use an antistatic container for transport of electrostatic-sensitive components and circuit boards.

### Notice

Calibrate the generator after you install a new heat sink or replace components on the heat sink. Component differences may affect output waveforms. Refer to *Calibrating the Generator* on page 5-26, for instructions.

## Remove the Left Front Heat Sink

1. Turn off the generator. Disconnect the power cord from the wall receptacle.
2. Remove the five screws that secure the cover to the chassis. Lift the cover off the chassis. Save the cover and screws for reinstallation.
3. Remove the Control board.
  - a. Unlock the connector on the Control board and disconnect the Display board ribbon cable from the Control board.
  - b. Carefully slide the Control board straight up through the slots on the heat sinks to disconnect it from the Power Supply/RF board. Set the board aside in an antistatic container for reinstallation.
4. Remove the three screws (one plastic and two metal) that secure the support bracket to the heat sinks. Save the screws and bracket for reinstallation.
5. On the left side of the chassis, remove the two screws that secure the base of the left front heat sink to the rail under the Power Supply/RF board. Save the screws for reinstallation.
6. Lift the heat sink to disconnect it from the Power Supply/RF board.

If you plan to replace one or more components on the existing heat sink, go to *Replace Left Front Heat Sink Components* on page 7-16.

or

If you plan to replace the entire left front heat sink assembly, go to *Install the Left Front Heat Sink* on page 7-16.

## Replace Left Front Heat Sink Components

### Replacing left front heat sink components

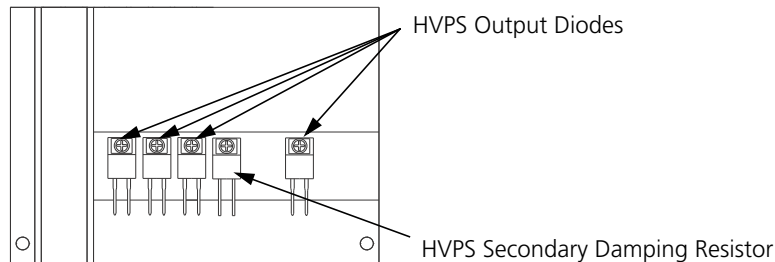

- To replace one or more HVPS (high voltage power supply) output diodes, remove the screw and shoulder washer that secure the diode to the heat sink. Position the new diode on the heat sink and reinstall the shoulder washer and screw.
- To replace the HVPS secondary damping resistor, remove the screw that secures it to the heat sink. Position the new resistor on the heat sink and reinstall the screw.

## Install the Left Front Heat Sink

1. Inspect the assembly for bent pins. On the left side of the chassis, carefully slide the heat sink down into the matching connectors on the Power Supply/RF board.
2. Install the two screws that secure the left front heat sink to the rail under the Power Supply/RF board.
3. Position the support bracket over the heat sinks and install the three screws that secure the bracket to the left rear heat sink (plastic screw) and to the left front and right heat sinks (two metal screws).
4. Install the Control board.
  - a. Position the Control board over the Power Supply/RF board with the Control board components facing the rear panel. Fit the edges of the board into the slots on the heat sinks. Slide the board down, carefully fitting the edge connector into the matching connector on the Power Supply/RF board.
  - b. Connect the Display board ribbon cable to the Control board and lock the connector.
5. Position the cover above the chassis and slide it down. Install the five screws that secure the cover to the chassis.

## Left Rear Heat Sink and Component Replacement

### Equipment required

- Phillips screwdriver

### Warning

**Electric Shock Hazard** To allow stored energy to dissipate after power is disconnected, wait at least five minutes before replacing parts.

### Precaution

The generator contains electrostatic-sensitive components. When repairing the generator, work at a static-control workstation. Wear a grounding strap when handling electrostatic-sensitive components, except when working on an energized generator. Handle circuit boards by their nonconductive edges. Use an antistatic container for transport of electrostatic-sensitive components and circuit boards.

### Notice

Calibrate the generator after you install a new heat sink or replace components on the heat sink. Component differences may affect output waveforms. Refer to *Calibrating the Generator* on page 5-26, for instructions.

## Remove the Left Rear Heat Sink

1. Turn off the generator. Disconnect the power cord from the wall receptacle.
2. Remove the five screws that secure the cover to the chassis. Lift the cover off the chassis. Set the cover and screws aside for reinstallation.
3. Remove the three screws (one plastic and two metal) that secure the support bracket to the heat sinks. Save the screws and bracket for reinstallation.
4. Disconnect the 4-wire heat sink (bridge rectifier) cable from the Power Supply/RF board.
5. Loosen but do not remove the screw securing the component clip below the bridge rectifier.
6. On the left side of the chassis, remove the two screws that secure the base of the left rear heat sink to the rail under the Power Supply/RF board. Save the screws for reinstallation.
7. Lift the left rear heat sink to disconnect it from the Power Supply/RF board.

If you plan to replace one or more components on the existing heat sink, go to *Replace Left Rear Heat Sink Components* on page 7-18.

or

If you plan to replace the entire left rear heat sink assembly, go to *Install the Left Rear Heat Sink* on page 7-18.

## Replace Left Rear Heat Sink Components

### Components of the left rear heat sink

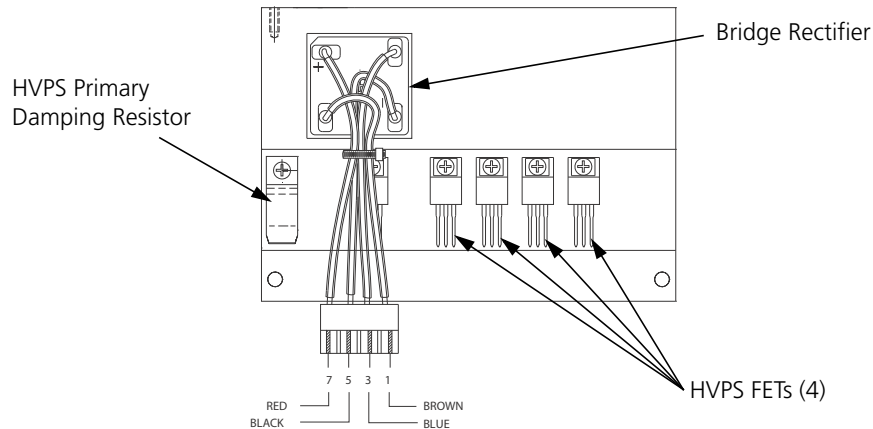

- To replace the HVPS (high voltage power supply) primary damping resistor, remove the screw and shoulder washer that secure it to the heat sink. Position the new resistor on the heat sink and reinstall the washer and screw.
- To replace one or more of the four HVPS FETs, remove the screw and shoulder washer that secure the FET to the heat sink. Position the new FET on the heat sink and reinstall the washer and screw.
- To replace the bridge rectifier, note the orientation of the four wires. Mark them for reinstallation. Then, detach them from the rectifier.

Remove the screw that secures the rectifier to the heat sink. Position the new bridge rectifier on the heat sink and reinstall the screw.

Connect the four wires to the appropriate terminal on the rectifier.

## Install the Left Rear Heat Sink

1. Position the left rear heat sink over the matching connectors on the Power Supply/RF board. Slide the components into the connectors.
2. Install the two screws that secure the left rear heat sink to the rail.
3. Connect the 4-wire heat sink (bridge rectifier) cable to J8 on the Power Supply/RF board.
4. Tighten the screw securing the component clip over the Triac Thermister.
5. Position the support bracket over the heat sinks and install the three screws that secure the bracket to the left rear heat sink (plastic screw) and to the left front and right heat sinks (two metal screws).
6. Position the cover above the chassis and slide it down. Install the five screws that secure the cover to the chassis.

## Right Heat Sink and Component Replacement

### Equipment required

- Phillips screwdriver

### Warning

**Electric Shock Hazard** To allow stored energy to dissipate after power is disconnected, wait at least five minutes before replacing parts.

### Precaution

The generator contains electrostatic-sensitive components. When repairing the generator, work at a static-control workstation. Wear a grounding strap when handling electrostatic-sensitive components, except when working on an energized generator. Handle circuit boards by their nonconductive edges. Use an antistatic container for transport of electrostatic-sensitive components and circuit boards.

### Notice

Calibrate the generator after you install a new heat sink or replace components on the heat sink. Component differences may affect output waveforms. Refer to *Calibrating the Generator* on page 5-26, for instructions.

## Remove the Right Heat Sink

1. Turn off the generator. Disconnect the power cord from the wall receptacle.
2. Remove the five screws that secure the cover to the chassis. Lift the cover off the chassis. Set the cover and screws aside for reinstallation.
3. Remove the Control board.
  - a. Unlock the connector on the Control board and disconnect the Display board ribbon cable from the Control board.
  - b. Carefully slide the Control board straight up through the slots on the heat sinks to disconnect it from the Power Supply/RF board. Set the board aside in an antistatic container for reinstallation.
4. Remove the three screws (one plastic and two metal) that secure the support bracket to the heat sinks. Save the screws and bracket for reinstallation.
5. Disconnect the cable from the tank damping resistor on the right heat sink from J12 on the Power Supply/RF board.
6. On the right side of the chassis, remove the two screws that secure the base of the right heat sink to the rail under the Power Supply/RF board. Save the screws for reinstallation.
7. Lift the heat sink to disconnect it from the Power Supply/RF board.

If you plan to replace one or more components on the existing heat sink, go to *Replace Right Heat Sink Components* on page 7-20.

or

If you plan to replace the entire right heat sink assembly, go to *Install the Right Heat Sink* on page 7-21.

## Replace Right Heat Sink Components

### Components of the right heat sink

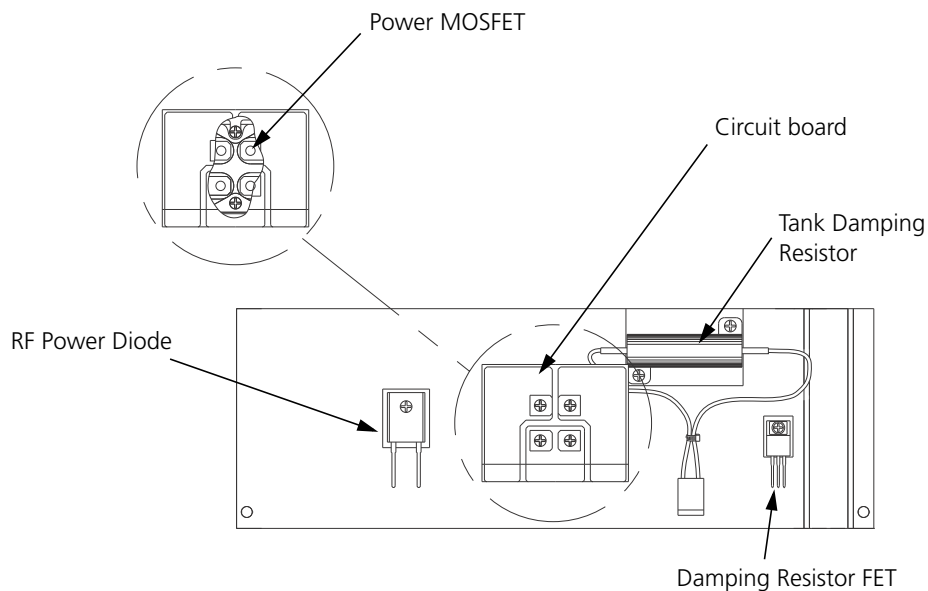

- To replace the damping resistor FET, remove the screw and shoulder washer that secure it to the heat sink. Position the new damping resistor FET on the heat sink and reinstall the washer and screw.
- To replace the RF power diode, remove the screw and shoulder washer that secure the diode to the heat sink. Position the new RF power diode on the heat sink and reinstall the washer and screw.
- To replace the tank damping resistor, remove the two screws that secure the top and bottom of the resistor to the heat sink. Position the new tank damping resistor on the heat sink and reinstall the screws.
- To replace the power MOSFET (under the small circuit board), remove the four screws that secure the small circuit board to the heat sink. Set the board and screws aside for reinstallation.

Note the orientation of the power MOSFET. Then, remove the two screws that secure it to the heat sink. Position the new power MOSFET on the heat sink and reinstall the two screws.

Position the small circuit board over the power MOSFET and reinstall the four screws that secure the board to the heat sink.

## Install the Right Heat Sink

1. On the right side of the chassis, slide the heat sink components down into the matching connectors on the Power Supply/RF board.
2. Install the two screws that secure the right heat sink to the rail under the Power Supply/RF board.
3. Connect the right heat sink tank damping resistor cable to J12 on the Power Supply/RF board.
4. Position the support bracket over the heat sinks and install the three screws that secure the bracket to the left rear heat sink (plastic screw) and to the left front and right heat sinks (two metal screws).
5. Install the Control board.
  - a. Position the Control board over the Power Supply/RF board with the Control board components facing the rear panel. Fit the edges of the board into the slots on the heat sinks. Slide the board down, carefully fitting the edge connector into the matching connector on the Power Supply/RF board.
  - b. Connect the Display board ribbon cable to the Control board and lock the connector.
6. Position the cover above the chassis and slide it down. Install the five screws that secure the cover to the chassis.

## Low Voltage Power Supply Replacement

### Equipment required

- Phillips screwdriver

### Warning

**Electric Shock Hazard** To allow stored energy to dissipate after power is disconnected, wait at least five minutes before replacing parts.

### Precaution

The generator contains electrostatic-sensitive components. When repairing the generator, work at a static-control workstation. Wear a grounding strap when handling electrostatic-sensitive components, except when working on an energized generator. Handle circuit boards by their nonconductive edges. Use an antistatic container for transport of electrostatic-sensitive components and circuit boards.

## Remove the Low Voltage Power Supply

1. Turn off the generator. Disconnect the power cord from the wall receptacle.
2. Remove the five screws that secure the cover to the chassis. Lift the cover off the chassis. Set the cover and screws aside for reinstallation.
3. Remove the three screws (one plastic and two metal) that secure the support bracket to the heat sinks. Save the screws and bracket for reinstallation.
4. Disconnect and remove the low voltage power supply.
  - a. Disconnect the Power Supply/RF board cables from the low voltage power supply (red spade lug and 3-pin connector at the rear; 6-pin connector at the front). Mark the cables for reinstallation.
  - b. Remove the four screws that secure the low voltage power supply to the Power Supply/RF board. Save them for reinstallation.
  - c. Lift the low voltage power supply off the Power Supply/RF board.

## Install the Low Voltage Power Supply

1. Place the new low voltage power supply on the Power Supply/RF board and install the four screws that secure it to the board.
2. Facing the front of the unit, connect the cables from the Power Supply/RF board to the new low voltage power supply.

**Low voltage power supply**

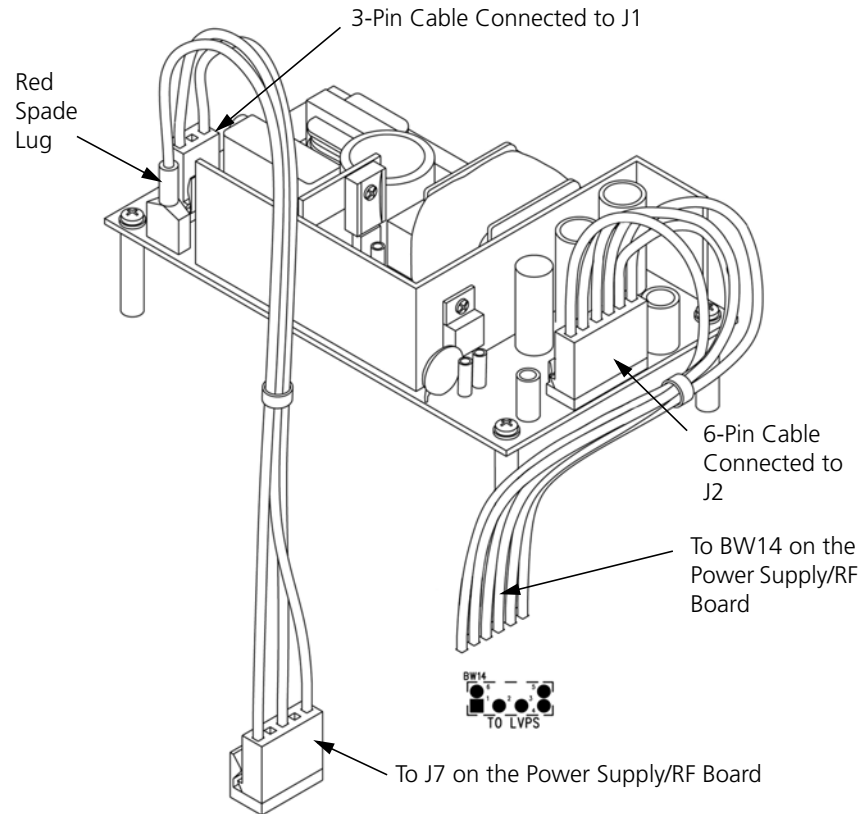

- a. Connect the 3-pin cable to J1 at the rear of the low voltage power supply. Verify that this cable is connected to J7 on the Power Supply/RF board.
- b. Connect the red spade lug with the green and yellow ground wire to the ground lug on the left rear corner of the low voltage power supply.
- c. Connect the 6-pin cable to J2 at the front of the low voltage power supply. Solder the six wires from the opposing end of this cable to the Power Supply/RF board as follows:
  - J2 pin 1 (orange wire) to location BW14 pin 3 on Power Supply/RF board
  - J2 pin 2 (red wire) to location BW14 pin 1 on Power Supply/RF board
  - J2 pin 3 (red wire) to location BW14 pin 6 on Power Supply/RF board
  - J2 pin 4 (black wire) to location BW14 pin 4 on Power Supply/RF board
  - J2 pin 5 (black wire) to location BW14 pin 5 on Power Supply/RF board
  - J2 pin 6 (blue wire) to location BW14 pin 2 on Power Supply/RF board

3. Position the support bracket over the heat sinks and install the three screws that secure the bracket to the left rear heat sink (plastic screw) and to the left front and right heat sinks (two metal screws).
4. Position the cover above the chassis and slide it down. Install the five screws that secure the cover to the chassis.

## Power Entry Module Replacement

### Equipment required

- Phillips screwdriver

#### Warning

**Electric Shock Hazard** To allow stored energy to dissipate after power is disconnected, wait at least five minutes before replacing parts.

#### Precaution

The generator contains electrostatic-sensitive components. When repairing the generator, work at a static-control workstation. Wear a grounding strap when handling electrostatic-sensitive components, except when working on an energized generator. Handle circuit boards by their nonconductive edges. Use an antistatic container for transport of electrostatic-sensitive components and circuit boards.

## Remove the Power Entry Module

1. Turn off the generator. Disconnect the power cord from the wall receptacle.
2. Disconnect the power cord from the power entry module.
3. Remove the five screws that secure the cover to the chassis. Lift the cover off the chassis. Set the cover and screws aside for reinstallation.
4. Disconnect the power entry module cable from J6 on the Power Supply/RF board.
5. Remove the two screws that secure the power entry module to the rear panel. Save the screws for reinstallation.
6. Slide the module out the rear panel until you can access the grounding lug post inside the rear panel. Then, remove the nut and washer that secure the ground wire ring terminal to the grounding lug. Save the nut and washer for reinstallation.
7. Slide the ring terminal off the post and remove the power entry module assembly from the unit.

## Install the Power Entry Module

1. Check the cable connections on the new power entry module, using the illustration or the module you just removed as a reference.
2. Position the new power entry module near the rear panel opening, routing the cable/ ring terminal through the opening.

### **Cable connections on the power entry module**

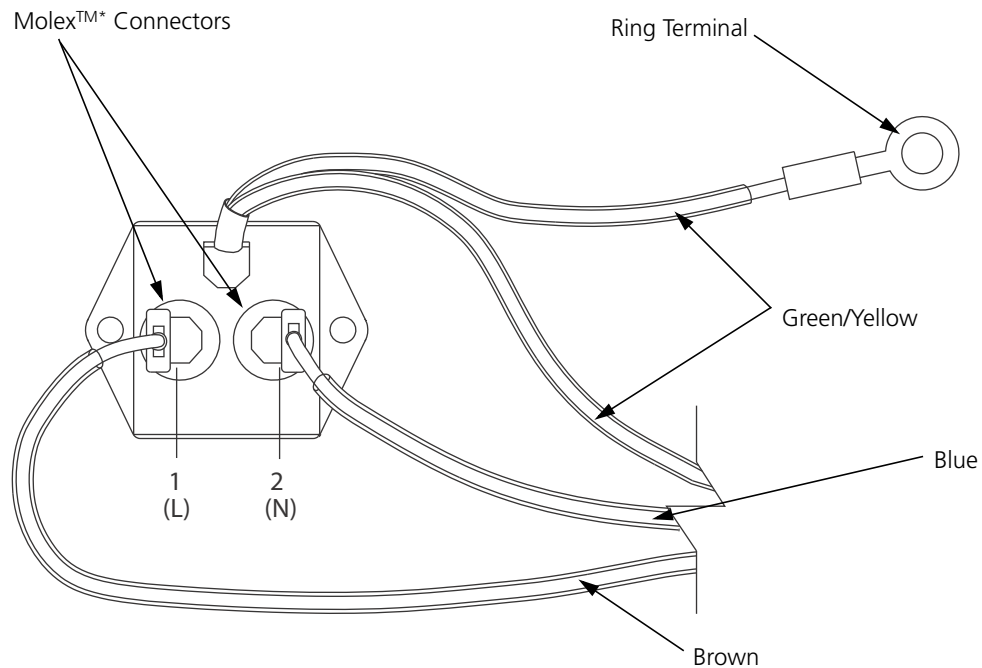

3. Slide the ground wire ring terminal onto the grounding lug post on the rear panel. Then, install the washer and nut that secure the ring terminal to the post.
4. Press firmly to snap the power entry module in place. Install the two screws that secure it to the rear panel.
5. Connect the power entry module cable to J6 on the Power Supply/RF board.
6. Position the cover above the chassis and slide it down. Install the five screws that secure the cover to the chassis.
7. Reconnect the power cord to the rear panel.

## Power Supply/RF Board Replacement

### Equipment required

- Phillips screwdriver

### Warning

**Electric Shock Hazard** To allow stored energy to dissipate after power is disconnected, wait at least five minutes before replacing parts.

### Precaution

The generator contains electrostatic-sensitive components. When repairing the generator, work at a static-control workstation. Wear a grounding strap when handling electrostatic-sensitive components, except when working on an energized generator. Handle circuit boards by their nonconductive edges. Use an antistatic container for transport of electrostatic-sensitive components and circuit boards.

### Notice

Calibrate the generator after you install a new Power Supply/RF board. Component differences may affect output waveforms. Refer to *Calibrating the Generator* on page 5-26.

## Remove the Power Supply/RF Board Assembly

1. Turn off the generator. Disconnect the power cord from the wall receptacle.
2. Remove the five screws that secure the cover to the chassis. Lift the cover off the chassis. Set the cover and screws aside for reinstallation.
3. Disconnect and remove the front panel assembly.
  - a. Unlock the connector on the Control board and disconnect the Display board ribbon cable from the Control board.
  - b. Disconnect the power switch cable from the Power Supply/RF board.
  - c. Disconnect the two REM connectors from the Power Supply/RF board.
  - d. Remove the four screws that secure the front panel to the chassis. Save the screws for reinstallation.
  - e. Slide the front panel assembly forward, carefully disengaging it from the electrical contacts on the Power Supply/RF board.
4. Disconnect the Footswitch Board ribbon cable from the Power Supply/RF board.
5. Disconnect the power entry module from the Power Supply/RF board.
6. Remove the four screws that secure the rail to the chassis. Also remove the screw in the center of the Power Supply/RF board (behind the Control board). Save the screws for reinstallation.
7. Remove the assembly (Power Supply/RF board, heat sinks, Control board, low voltage power supply, fan) from the chassis.

## Remove Components from the Old Board

### Important

Save all parts, screws, brackets, etc. for reinstallation.

1. To remove the Control board, carefully slide the Control board straight up to disconnect it from the Power Supply/RF board. Set the board aside in an antistatic container for reinstallation.
2. To remove the support bracket, remove the three screws that secure the bracket to the top of the heat sinks.
3. To remove the left front heat sink, remove the two screws that secure the base of the heat sink to the rail under the Power Supply/RF board. Lift the heat sink to disconnect it from the Power Supply/RF board.
4. Remove the left rear heat sink.
  - a. Disconnect the 4-wire heat sink (bridge rectifier) cable from the Power Supply/RF board.
  - b. On the left side of the chassis, remove the two screws that secure the base of the left rear heat sink to the rail under the Power Supply/RF board. Lift the heat sink to disconnect it from the Power Supply/RF board.
  - c. Loosen but do not remove the screw securing the component clip below the bridge rectifier.
5. Remove the right heat sink.
  - a. Disconnect the right heat sink cable from the Power Supply/RF board.
  - b. On the right side of the chassis, remove the two screws that secure the base of the heat sink to the rail under the Power Supply/RF board. Save the screws for reinstallation. Lift the heat sink to disconnect it from the Power Supply/RF board.
6. Remove the low voltage power supply.
  - a. Disconnect the low voltage power supply cables from the Power Supply/RF board at J7.
  - b. Disconnect the 6-pin cable that is connected to J2 on the low voltage power supply.
  - c. Remove the four screws that secure the low voltage power supply to the Power Supply/RF board. Remove the low voltage power supply.
7. Remove the fan.
  - a. Disconnect the fan control connector from the Power Supply/RF board.
  - b. Remove the four screws and nuts that secure the fan to the underside of the Power Supply/RF board.

## Install Components on the New Board

Follow these steps to reinstall the components you removed from the existing board onto the new Power Supply/RF board.

1. Install the fan on the new Power Supply/RF board.
  - a. Position the fan on the underside of the Power Supply/RF board and install the four nuts and screws that secure it to the board.
  - b. Connect the fan control connector to J4 on the Power Supply/RF board.
2. Install the low voltage power supply on the new board.
  - a. Place the low voltage power supply on the Power Supply/RF board and install the four screws that secure it to the board.
  - b. Connect the 6-pin low voltage power supply cable to J7 on the Power Supply/RF board.
  - c. Connect the 6-pin low voltage power supply cable located at BW14 on the Power Supply/RF board to J2 on the low voltage power supply.
3. Install the right heat sink.
  - a. On the right side of the Power Supply/RF board, slide the right heat sink components into the matching connectors.
  - b. Install the two screws that secure the heat sink to the rail under the board.
  - c. Connect the right heat sink cable to J12 on the Power Supply/RF board.
4. Install the left rear heat sink.
  - a. Slide the left rear heat sink components into the matching connectors on the left rear of the Power Supply/RF Board.
  - b. Install the two screws that secure the heat sink to the rail under the board.
  - c. Tighten the screw securing the component clip over the Triac Thermister.
  - d. Connect the 4-wire heat sink (bridge rectifier) cable to J8 on the Power Supply/RF board.
5. Install the left front heat sink on the new board.
  - a. Slide the left front heat sink into the matching connectors on the left front of the Power Supply/RF board.
  - b. Install the two screws that secure the heat sink to the rail under the board.
6. Position the support bracket over the heat sinks and install the three screws that secure the bracket to the left rear heat sink (plastic screw) and to the left front and right heat sinks (two metal screws).
7. To install the Control board, position the board over the Power Supply/RF board with the Control board components facing the rear panel. Fit the edges of the board into the slots on the heat sinks. Slide the board down, carefully fitting the edge connector into the matching connector on the Power Supply/RF board.

## Install the Power Supply/RF Board Assembly

1. Position the Power Supply/RF board assembly on the floor of the chassis and install the four screws that secure the rail to the chassis. Install the screw in the center of the board (behind the Control board).
2. Connect the power entry module cable to J6 on the Power Supply/RF board.
3. Connect the Footswitch board ribbon cable to J5 on the Power Supply/RF board.
4. Install the front panel assembly.
  - a. Position the front panel assembly in front of the chassis and carefully slide it into the electrical contacts on the Power Supply/RF board.
  - b. Install the four screws that secure the front panel to the chassis.
  - c. Connect the REM wires to the Power Supply/RF board.
  - d. Connect the white wires with the 2-pin nonlocking connector to J15.
  - e. Connect the red wires with the 2-pin locking connector to J17.
  - f. Connect the power switch cable to J10 on the Power Supply/RF board.
  - g. Connect the Display board ribbon cable to the Control board and lock the connector.
5. Position the cover above the chassis and slide it down. Install the five screws that secure the cover to the chassis.



# Chapter 8

## Repair Policy and Procedures

This section contains the following information:

- The manufacturer's responsibility
- Returning the Force FX Electrosurgical Generator C for service
- Returning circuit boards
- Service centers

## Responsibility of the Manufacturer

Covidien is responsible for the safety, reliability, and performance of the generator only under the following circumstances:

- Installation and setup procedures in this manual are followed.
- Assembly operation, readjustments, modifications, or repairs are carried out by persons authorized by Covidien.
- The electrical installation of the relevant room complies with local codes and regulatory requirements, such as the IEC and BSI.
- The equipment is used in accordance with the Covidien instructions for use.

For warranty information, refer to the *Limited Warranty* in this manual.

## Returning the Generator for Service

Before you return the generator, call your Covidien Representative for assistance. If you are instructed to send the generator to Covidien, first obtain a Return Authorization Number. Then, clean the generator and ship it to Covidien for service.

## Obtain a Return Authorization Number

Call the Covidien Customer Service Center for your area to obtain a Return Authorization Number. Have the following information ready when you call:

- Hospital/clinic name/customer number
- Telephone number
- Department/address, city, state, and zip code
- Model number
- Serial number
- Description of the problem
- Type of repair to be done

## Clean the Generator

### Warning

**Electric Shock Hazard** Always turn off and unplug the generator before cleaning.

### Notice

Do not clean the generator with abrasive cleaning or disinfectant compounds, solvents, or other materials that could scratch the panels or damage the generator.

1. Turn off the generator, and unplug the power cord from the wall outlet.
2. Thoroughly wipe all surfaces of the generator and power cord with a mild cleaning solution or disinfectant and a damp cloth. Follow the procedures approved by your institution or use a validated infection control procedure. Do not allow fluids to enter the chassis. The generator cannot be sterilized.

## Ship the Generator

1. Attach a tag to the generator that includes the Return Authorization Number and the information (hospital, phone number, etc.) listed in *Obtain a Return Authorization Number* on page 8-2.
2. Be sure the generator is completely dry before you pack it for shipment. Package it in its original shipping container, if available.
3. Ship the generator, prepaid, to the Covidien Service Center.

## Returning Circuit Boards

Package circuit boards for shipment as follows:

1. Place each circuit board in an electrostatic discharge (ESD) bag or container.
2. Provide a separate packing container for each circuit board.
3. Attach a tag to the container that includes the Return Authorization Number and the information (hospital, phone number, etc.) listed previously in *Obtain a Return Authorization Number* on page 8-2.
4. Ship the circuit board prepaid to the Covidien Service Center.

## Service Centers

For a complete list of service centers worldwide, please refer to the Covidien web site:

<http://surgical.covidien.com/international-service-centers>

## **Training/Education**

For clinical professionals and service training options, please refer to the Covidien web site: <http://www.covidien.com/education>

# Chapter 9

## Service Parts

Replacement parts for the Force FX Electrosurgical Generator C are listed in this section. If the part number is not listed for a specific item, a replacement for that item is not available.

All components must be replaced with parts of identical construction and value. Replacement ratings and tolerances must be equal to or better than the original.

### **Warning**

No modification of this equipment is allowed.

## **Ordering Replacement Parts**

You can order parts for the Force FX Electrosurgical Generator C from the Covidien Service Center for your location.

When ordering replacement parts, include this information:

- Model number (located on the rear panel of the generator)
- Serial number (located on the rear panel of the generator)
- Part number (for the part you are ordering)
- Modification number, if applicable.

If you do not know the part number or if you wish to order spare parts, call the Covidien Service Center for assistance.

# Generator Assembly

## Generator assembly

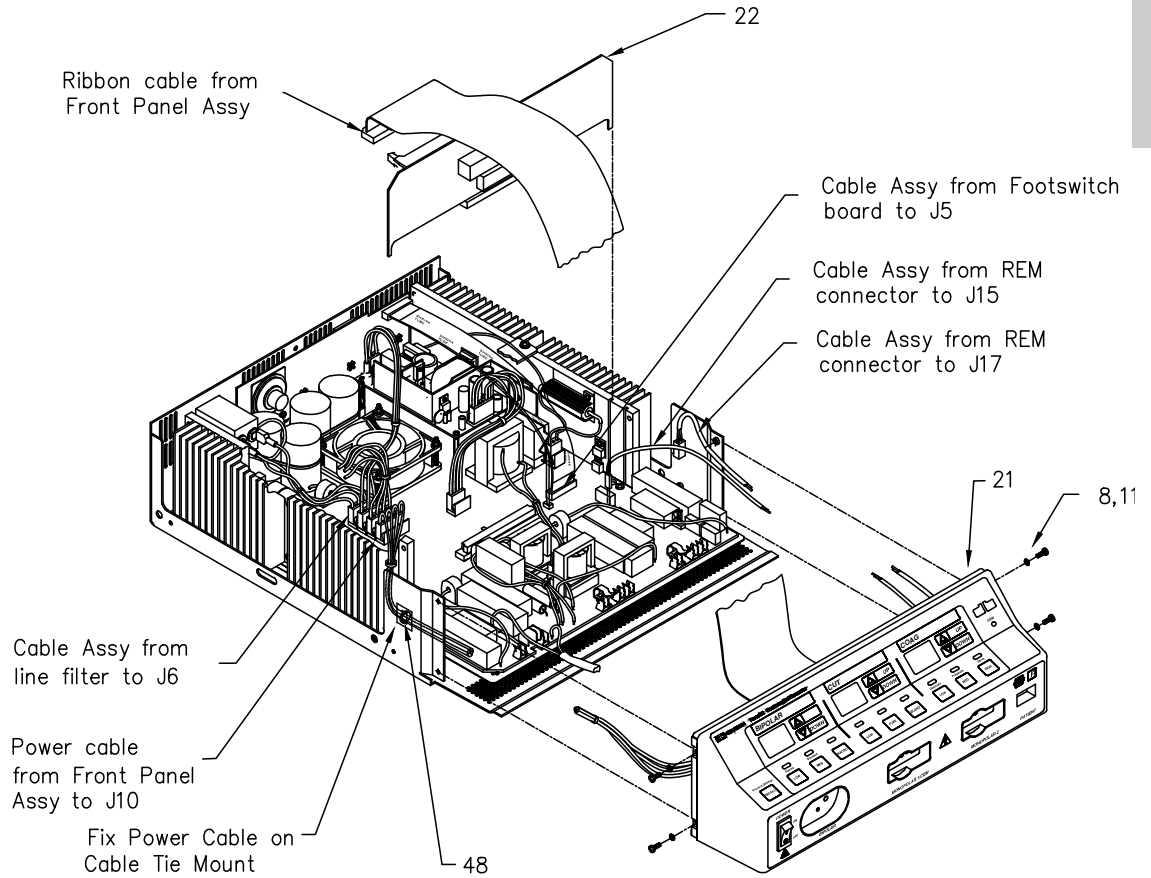

**Generator assembly—continued**

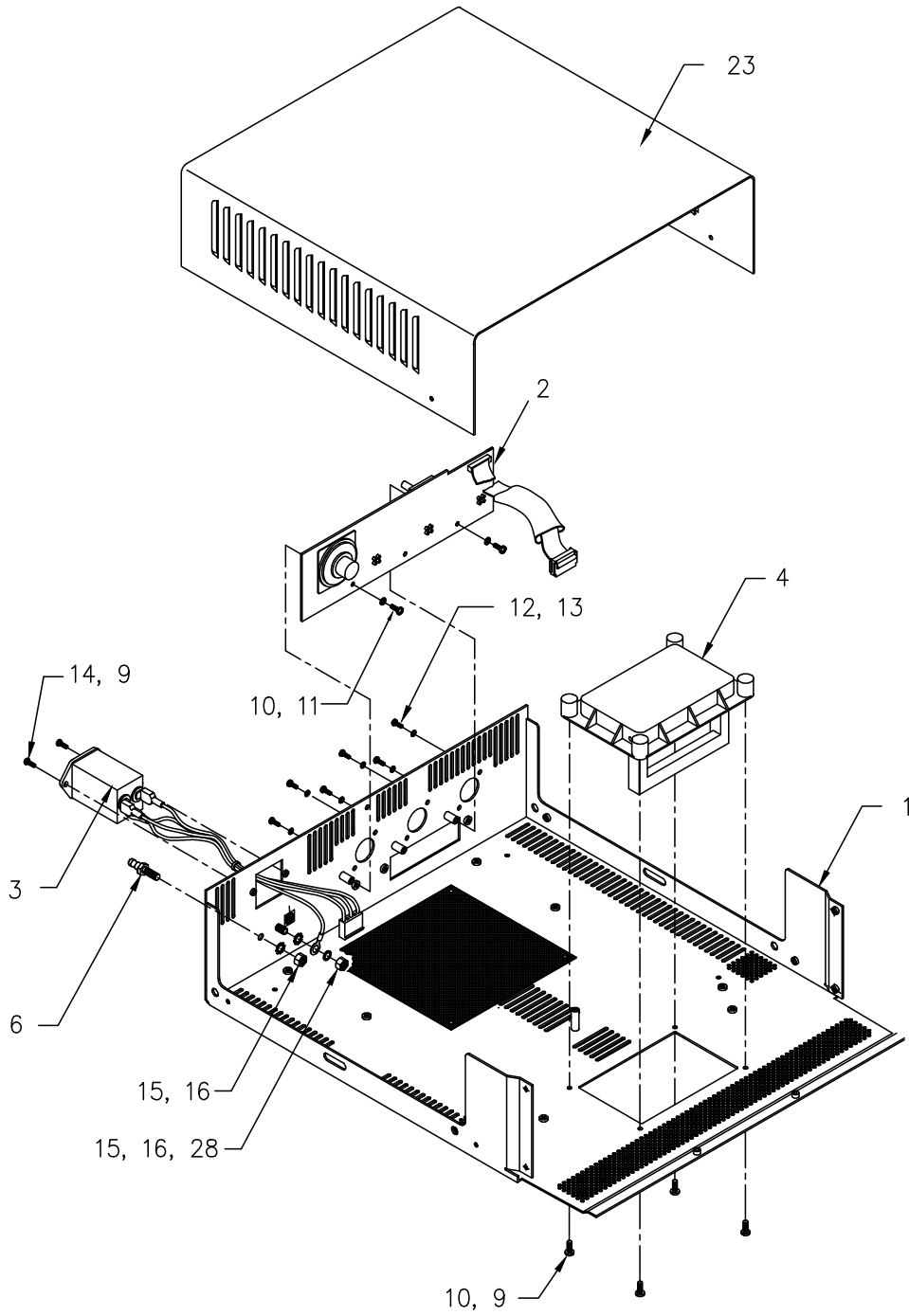

## Parts List

Item	Description	Part Number
1	Chassis, lower	1081476
2	Assembly, Footswitch board <i>See Footswitch Board Components in this section.</i>	1052932
3	Cable assembly, line filter <i>Includes</i> Cable, filter line ground Cable, filter line Tubing, heatshrink black 1/4 ID Line filter, 10 amp Fuse, 8A, 5x20 mm Slow Blow	202 701 890 207 500 723 207 500 543 249 001 002 251 400 007 215 100 070
4	Handle, collapsible tray	223 300 054
6	Equipotential ground lug	208 200 141
8	Screw, Phillips M4 x 0.7 x 10	237 050 139
9	Sealant, loctite #222	232 301 148
10	Screw, panhead Phillips M4 x 0.7 x 8 mm	237 050 113
11	Washer, lock internal metric M4	253 300 045
12	Screw, panhead Phillips M3 x 0.5 x 12 zinc	237 050 135
13	Washer, lock internal metric M3	253 300 044
14	Screw, panhead M3 x 0.5 x 8 zinc	237 050 149
15	Lockwasher, M6 ext tooth	253 300 000
16	Nut, hex M6 x 10 brass nickel plated	224 300 000
21	Assembly, front panel <i>See Front Panel Assembly on page 9-7.</i>	1081734 / 1080592 BCMA / SHMA
22	Assembly, Programmed control board <i>See Control Board Components on page 9-10.</i>	1081721
23	Cover, upper	1012587 / 1032764 BCMA / SHMA

<b>Item</b>	<b>Description</b>	<b>Part Number</b>
28	Washer, metric M6	253 300 046
48	Cable tie	555 049 001 / F150022
<b>Not shown</b>		
	Insulator handle	214 100 104
	Assembly, Power Supply/RF board <i>See Power Supply/RF Board Assembly on page 9-16 and Supply/RF Board Components on page 9-21.</i>	1052930
	Cover plate	223 301 139
	Power cord, right angle molded, 110V	207 002 060
	Fuse, 8A, 5x20 mm Slow Blow (2)	215 100 070
	Washer, flat M4	253 300 005
	Tag, receptacle notice	216 151 414
	Rubber foot	1005706
	Battery 3V	1053105

# Front Panel Assembly

*Front panel assembly*

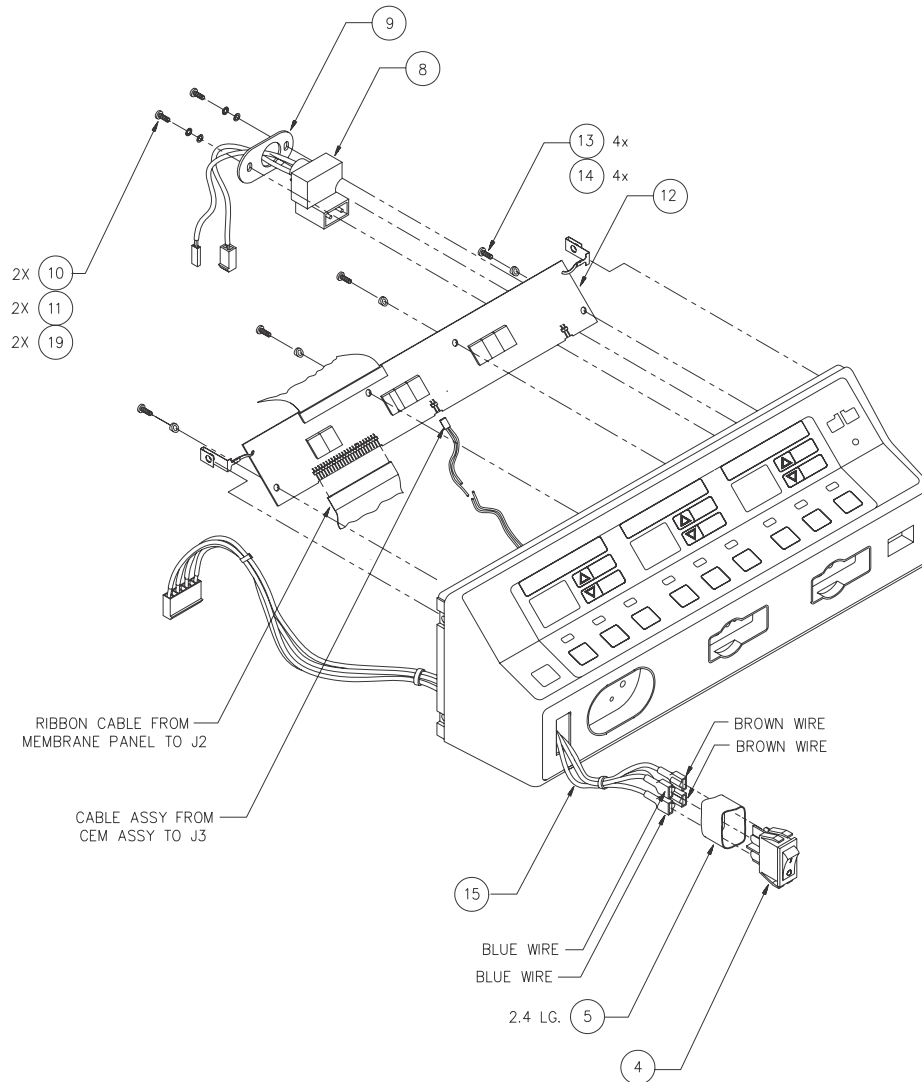

**Front panel assembly—continue**

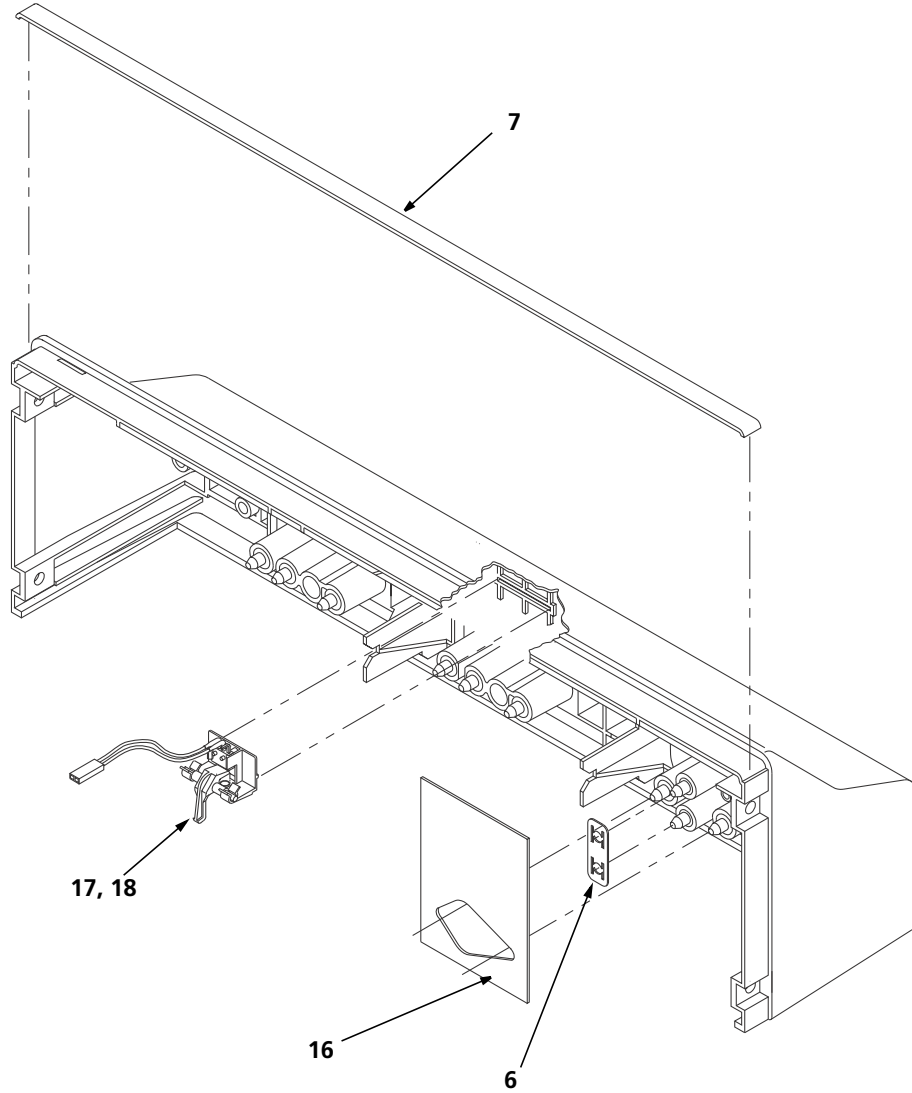

## Parts List

Item	Description	Part Number
4	Switch	243 025 037
5	Tubing, heatshrink 1 inch ID	249 001 010
6	Bipolar bracket	223 500 077
7	Tape, foam one-sided 1/16 x 1/4	232 301 185
8	Cable assembly, REM	1049479
9	REM retaining plate	1049490 / 1076223
10	Screw, panhead Phillips M3 x 0.5 x 12 zinc	237 050 135
11	Washer, lock internal metric M3	253 300 044
12	Assembly, Display board <i>See Display Board Components on page 9-10.</i>	1058979
13	Screw, thread forming #4-20 0.625	237 050 147
14	Display board spacer	223 400 626
15	Cable assembly, power switch	207 500 213
16	Shroud, bipolar	223 100 998
17	Assembly, CEM switch	S1052008
18	Adhesive, prism 411	232 301 004
19	Washer, flat M3	253 300 004
<b>Not shown</b>		
	Overlay jack	1049875
	Keyboard front	1012634
	Control panel	223 200 667

## Control Board Components

Reference Designator	Description	Part Number
1	Effect mode controller PCB	1052935

## Display Board Components

Reference Designator	Description	Part Number
<b>Capacitors</b>		
C1, C2	CAP CER 0.01 $\mu$ F 50 V 10% X7R SMD 0603	1078153
C3, C4, C5, C6, C10	CAP CER 0.1 $\mu$ F 50 V 10% X7R SMD 0603	1078164
C7, C8, C9	CAP TANT 47 $\mu$ F 20 V 20% SMD D CASE	1078170
C11, C12, C13, C14, C15, C16, C17, C18, C19, C20, C21, C43, C44, C45, C46, C47, C48, C49, C50, C51, C52, C53	CAP MICA 30 PF 100 V 5% SMD 0805	1078179
C22, C23, C24, C25, C26, C27, C31, C32, C35, C36, C37, C38, C39, C40, C41, C42	CAP CER 240PF 50 V 5% NPO SMD 0603	1078168
C28, C29, C30, C33, C34	CAP CER 0.01 $\mu$ F 100 V 10% X7R SMD 0603	1078154
<b>LEDs and Lamps</b>		
D1	LED GRN 0.2 DIA	1041644
LP1, LP2, LP3, LP4, LP5, LP6, LP7, LP8, LP9, LP10, LP11, LP12	Lamp	1041648
<b>Transistors</b>		
Q1, Q2, Q3	XSTR FET N-CHAN 100 V 1A	1042942

Reference Designator	Description	Part Number
<b>Resistors</b>		
R1, R2, R3, R4	RES THICK FILM 2010 16 $\Omega$ 5% SMD	1078167
R5, R6, R7, R8, R9, R10, R11, R12	RES THICK FILM 1206 0 $\Omega$ SMD	1078165
R13, R16	RES NTWK 8 PIN SIP	1041650
R14, R15	RES THICK FILM 1206 100 $\Omega$ 5% SMD	1078152
R17, R18	RES NTWK SIP 0.12 W 2% 1k $\Omega$	1041651
R19, R20, R21	RES THICK FILM 1206 270K $\Omega$ 5% SMD	1078169
R33, R34, R35, R36, R37, R38, R39, R40, R41, R42, R43	RES THICK FILM 0603 100 $\Omega$ 1% SMD	1078166
R22, R23, R24, R25, R26, R27, R28, R29, R30, R31, R32, R44, R45, R46, R47, R48, R49, R50, R51, R52, R53, R54	VARISTOR 24V 0603	1078180
<b>Integrated Circuits</b>		
U1	IC DRVR DSPL 18 PIN SOIC ULN2803A	1078181
U2, U3	BICOLOR DSPL	1042943
U6, U10	IC LED DRVR 64 SEG 5V 28-PIN SOIC W	1078177
U4, U5, U7, U8, U9, U11, U12, U13	LED DSPL 7 SEG GRN HDSP561	1041646
U16, U17	IC 6 CHANNEL ESD PROTECTION	1078176
<b>Miscellaneous</b>		
L1, L2, L3, L4, L5, L6, L7, L8, L9, L10, L11, L12, L13, L14, L15, L16, L17, L18, L19, L20, L21, L22	FERRITE 3A 100 $\Omega$ 1206 SMD	1078178
J1	ASSY CABLE DISPLAY FORCEFXC	1043508
J3	CONN PC MALE 2-PINS	1041643

<b>Reference Designator</b>	<b>Description</b>	<b>Part Number</b>
J2	CONN 25 PIN R ANG	1041645
<b>Miscellaneous (not shown)</b>		
	SKT DIP 30 PIN GLD	1042945
	SKT IC 16 PIN	1042944
	CLIP DISPLAY BOARD	1043507

## Footswitch Board Components

Reference Designator	Description	Part Number
<b>Capacitors</b>		
C38, C47, C48, C49	CAP CER 1000 PF 100 V 10% X7R SMD 0603	1078188
C2, C14, C16, C18	CAP CER 0.01 $\mu$ F 100 V 10% X7R SMD 0603	1078154
C3, C4, C5, C6, C7, C12, C13, C15, C17, C20, C21, C22, C24, C26, C28, C29, C30, C31, C32, C33, C36, C45, C50	CAP CER 0.1 $\mu$ F 100 V 10% X7S SMD 0603	1078183
C1	CAP CER 4.7 $\mu$ F 25 V 10% X5R SMD 0805	1078182
C39, C40, C41, C42, C43, C51	CAP MICA 30 PF 100 V 5% SMD 0805	1078179
C8, C19, C23, C25, C34, C37	CAP CER 0.1 $\mu$ F 100 V 10% X7R SMD 0805	1078184
C44	CAP CER 2200 PF 100 V 10% X7R SMD 0805	1078189
C46	CAP CER 1 $\mu$ F 25 V 10% X5R SMD 0805	1078190
C52	CAP CER 0.1 $\mu$ F 50 V 10% X7R SMD 0805	1078191
C9, C10, C27	CAP TANT 22 $\mu$ F 25 V 20% SMD D CASE	1078185
C11	CAP CER 1 $\mu$ F 50 V 20% X7R SMD 0805	1078186
C35	P CER 0.022 $\mu$ F 100 V 10% X7R SMD 0805	1078187
<b>Diodes</b>		
D1, D2	DIODE SWITCH 100 V 0.15 A SOD 123	1078289
D3, D4, D5	TVS DIODE 5.5 VWM SOT 143	1078192
D6	DIODE ZENER 15 V 500 MW SOD 123	1078193
<b>Transistors</b>		

Reference Designator	Description	Part Number
Q1	TTL MOSFET N-CHANNEL 240 VDS TN2404KL	1042981
<b>Resistors</b>		
R1, R2, R3, R4, R7, R9	RES THICK FILM 1206 10 K $\Omega$ 5% SMD	1078196
R5, R31	RES THICK FILM 1210 10.0 K $\Omega$ 1% SMD	1078197
R6	RES THICK FILM 1206 6.8 K $\Omega$ 5% SMD	1078198
R8, R15, R22, R23, R26, R29	RES THICK FILM 1206 2 K $\Omega$ 5% SMD	1078199
R10	RES THICK FILM 1210 33.2 K $\Omega$ 1% SMD	1078200
R11	RES THICK FILM 1210 432 $\Omega$ 1% SMD	1078201
R12	Pot, 5 k $\Omega$	1042215
R13, R16, R20, R24, R27	RES THICK FILM 1210 1.40 K $\Omega$ 1% SMD	1078202
R14, R17, R18, R19, R21, R25, R28, R56	RES THICK FILM 1210 2.15 K $\Omega$ 1% SMD	1078203
R30	RES THICK FILM 1210 19.6 K $\Omega$ 1% SMD	1078204
R32	RES THICK FILM 1210 200 K $\Omega$ 1%	1078268
R33	RES THICK FILM 1210 5.11 K $\Omega$ 1% SMD	1078269
R34	RES THICK FILM 1206 56 K $\Omega$ 5% SMD	1078270
R35	RES THICK FILM 1206 100 K $\Omega$ 5% SMD	1078271
R37, R38, R39, R40, R41, R43, R48, R53	VARISTOR 24 V 0603	1078180
R36	RES THICK FILM 1206 1.20 K $\Omega$ 1% SMD	1078272
R42	RES 0805 1.00 K 1% $\Omega$ SMD	1078273
R44, R46, R49, R51, R54	RES THICK FILM 0603 7.50 K $\Omega$ 1% SMD	1078274

<b>Reference Designator</b>	<b>Description</b>	<b>Part Number</b>
R45, R47, R50, R52, R55	RES THICK FILM 0603 4.99 K $\Omega$ 1% SMD	1078275
R57	RES THICK FILM 0603 10.0 $\Omega$ 1% SMD	1078276
<b>Integrated Circuits</b>		
U1	IC COMPARATOR QUAD 15 V / 30 V 14-PIN SOIC	1078277
U2	CNVTR DC/DC HPR107	1047294
U3, U4, U5	IC COMPARATOR DUAL 18 V / 36 V 8-PIN SOIC	1078278
U6	IC OP AMP DUAL GP 16 V / 32 V 8-PIN SOIC	1078279
U7	IC AUDIO AMP SPEAKER 8-PIN SOIC	1078287
<b>Miscellaneous</b>		
ISO1, ISO2, ISO3, ISO4, ISO5	IC OPTOCOUPLER TRANSISTOR	1078288
SP1	SPKR 8 $\Omega$	1047286
<b>Not shown</b>		
	SPCR FTSW FORCE X	1047287
	CABLE 10-IN TWISTED PAIR 20-WIRE RIBBON	1078514
	SCR PNH M3 10 MM	1047291
	WSHR FLAT M3.01	1045722
	WSHR E.T. M3 STL	1047292
	NUT HEX STL ZINC PLD M3X0.5	1047290
	W TEF 24 AWG WHT	1047293

# Power Supply/RF Board Assembly

*Power Supply/RF board assembly*

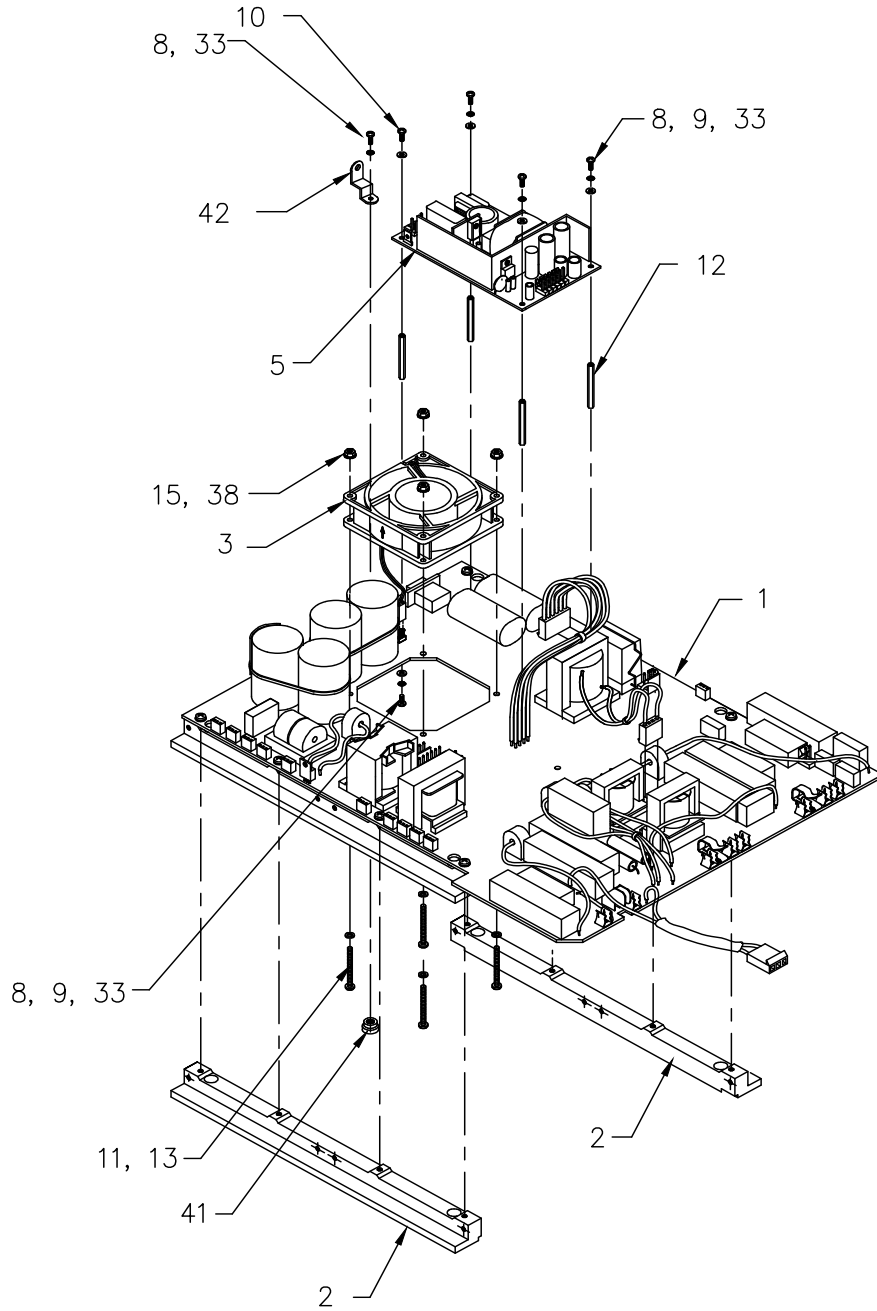

**Power Supply/RF board assembly—continued**

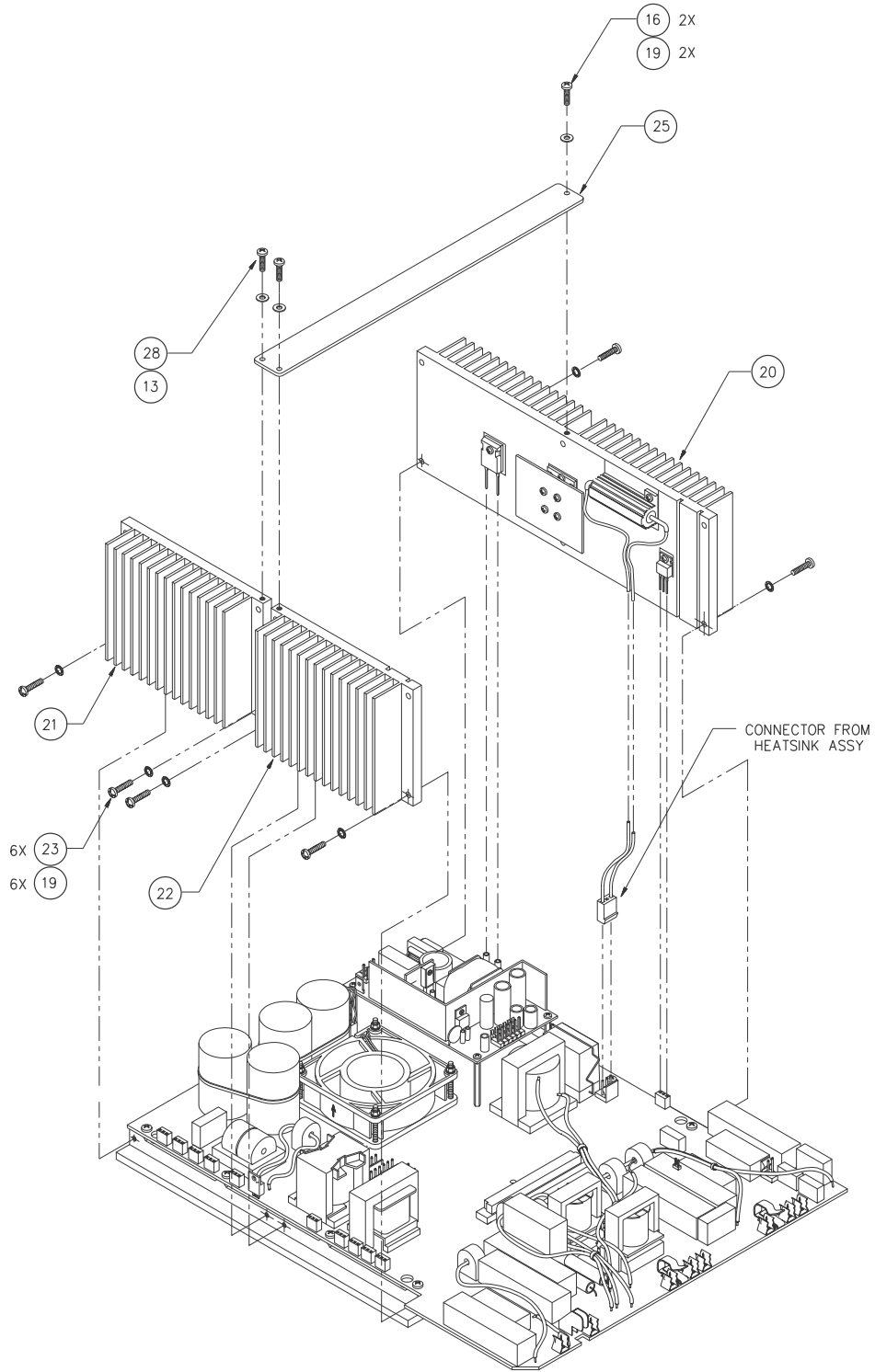

## Parts List

Item	Description	Part Number
1	PSRF BOARD	1078157
2	RAIL, MOUNT	1052545
3	ASSEMBLY, FAN	1049728
	<i>Includes</i>	
	FAN	1050021
	TERMINAL	1050022
	HOUSING	1050023
4	SOCKET, TRANSISTOR	1049715
5	POWER SUPPLY, LOW VOLTAGE	1049718
6	SOCKET (for pins with large lead diameter)	1049714
7	SOCKET RELAY	1049735
8	SCREW, PANHEAD M3 x 0.5 x 8 ZINC	1049775
9	WASHER, M3 NYLON	1049723
10	SCREW, PHILLIPS M3 x 0.5 x 8 NYLON	1049721
11	SCREW, PANHEAD PHILLIPS M4 x 0.7 x 35 ZINC	1049717
12	STANDOFF, HEX NYLON M3 x 37 F-F	1049720
13	WASHER, M4 NYLON	1049723
15	NUT, M4 x 0.7	1049719
16	SCREW, PANHEAD PHH M4 x 0.7 x 8 mm	1049730
18	SCREW, PANHEAD PHILLIPS M4 x 0.7 x 12 ZINC	1049729
19	LKWASH INTERNAL METRIC m 4.0	1049779

Item	Description	Part Number
20	ASSEMBLY, HEAT SINK, OUTPUT (right)	1078630
	<i>Includes</i>	
	CABLE ASSEMBLY, RESISTOR	1045737
	WASHER, SHOULDER	1045743
	RIGHT HEAT SINK	1078633
	PCB FET	1052506
	SCREW, PNH PHH M4 x 0.7 x 8 mm	1049780
	SCREW, PNH PHILLIPS M3 x 0.5 x 12 ZINC	1049782
	TRANSISTOR FET BUZ80A	1042978
	TRANSISTOR FET HI-V N-CH	1045740
	DIODE, ULTRA FAST 30 A, 1000 V	1042335
	WASHER, LOCK INTERNAL METRIC M4	1049779
21	ASSEMBLY, HEAT SINK, HIGH VOLTAGE (left rear)	1078311
	<i>Includes</i>	
	CABLE ASSEMBLY, RECTIFIER	1045723
	WASHER, SHOULDER	1045724
	LEFT REAR HEAT SINK	1078313
	RESISTOR, MF 150 $\Omega \pm 5\%$ , 20 W	1042270
	SCREW, PANHEAD PHILLIPS M3 x 0.5 x 12 ZINC	1049782
	TRANSISTOR FET N-CH 8 A, 500 V	1042350
	DIODE BRIDE 35 A, 400 V	1045714
	WASHER, FLATM3.0	1045722
	WASHER, LOCK INTERNAL M3	1049776
22	ASSEMBLY, HEAT SINK, RECTIFIER (left front)	1078315
	<i>Includes</i>	
	WASHER, SHOULDER	1045724
	LEFT FRONT HEAT SINK	1078316
	RESISTOR, MF 150 $\Omega \pm 5\%$ , 20 W	1042270
	SCREW, PANHEAD PHILLIPS M2.5 x 04.5 x 10 mm ZINC	1045720
	DIODE, FAST RECOVERY	1045748
23	PANHEAD PHILLIPS M4 x 0.7 x 20 mm	1049726
24	FUSE HOLDER	1049706
25	BRACKET, HEAT SINK SUPPORT	1052548
28	SCREW, PANHEAD PHILLIPS M4 x 0.7 x 8 NYLON	1049727
30	WIRE, TS, 20 AWG, YELLOW	1049731
31	SLEEVING, PVC CLEAR 11 AWG	1049733
32	WIRE, TS, 20 AWG, RED	1049732
33	WASHER, LOCK INTERNAL M3	1049776

<b>Item</b>	<b>Description</b>	<b>Part Number</b>
34	Tie wire	1049738
39	CABLE PSRF INTERNAL SERIAL FORCE FX	1078933
40	CLIP PSRF CABLE RETENTION	1078517
41	FASTNERS SMTSO-MR-2ET	1078305
42	BRKT PSRF GRND	1076217
<b>Not Shown</b>		
	SOCKET, TRANSISTOR	1049715
	SOCKET, PIN LG LEAD DIA.	1049714
	SOCKET RELAY	1049714
	SCREW, PANHEAD PHILLIPS M4 x 0.7 x 12 ZINC	1049729
	FUSE HOLDER	1049706
	CLIP, RELAY, 6-POLE	1049739
	ASSY, CABLE, AUTO BIPOLAR	1049741
	TUBING, HEAT SHRINK 3/8 ID	1049734
	CABLE ASSEMBLY, 6-WIRE POWER	1049742
	CABLE ASSEMBLY, 3-WIRE POWER	1049725

## Supply/RF Board Components

Reference Designator	Description	Part Number
<b>Capacitors</b>		
C1, C90	100 pF $\pm$ 5%, 100 V	1042261
C2, C43, C46, C48, C52, C65, C71, C82, C84, C86, C117, C118, C156, C170, C172	.01 $\mu$ F $\pm$ 20%, 50 V	1041635
C3, C10, C11, C22	680 $\mu$ F, 400 V	1042328
C4, C12, C13, C44, C50, C91, C93, C94, C96, C97, C102, C132, C134, C137, C139, C140, C141, C144, C145, C146, C148	.01 $\mu$ F $\pm$ 10%, 100 V	1047297
C5, C6, C7, C14, C15, C16, C17, C18, C19, C20, C21, C23, C181	CAP CER 1000 PF 100 V 10% X7R SMD 0603	1078188
C8	.22 $\mu$ F $\pm$ 20%, 250 V	1042249
C9	33 $\mu$ F $\pm$ 10%, 35 V	1042308
C58, C98, C99	CAP CER 0.01 $\mu$ F 100 V 10% X7R SMD 0603	1078283

Reference Designator	Description	Part Number
C24, C25, C26, C39, C61, C70, C113, C120, C122, C124, C127, C130, C136, C142, C147, C149, C160, C161, C162, C163, C164, C165, C166, C167, C168	1 $\mu\text{F} \pm 20\%$ , 50 V	1042288
C27, C49	680 pF $\pm 5\%$ , 500 V	1042327
C28, C36, C37, C38, C45, C47, C51, C53, C55, C56, C57, C62, C64, C72, C74, C78, C80, C83, C88, C89, C92, C95, C103, C106, C109, C110, C114, C115, C116, C121, C123, C125, C128, C131, C133, C135, C138, C143, C153, C173	.1 $\mu\text{F} \pm 20\%$ , 50 V	1041634
C29	2 $\mu\text{F} \pm 10\%$ , 400 V	1042300
C30	180 pF $\pm 5\%$ , 100 V	1042277
C31, C87	22 $\mu\text{F} \pm 20\%$ , 25 V	1042294
C32	1 $\mu\text{F} \pm 10\%$ , 250 V	1042287
C33, C35	15 $\mu\text{F} \pm 10\%$ , 200 V	1042275
C34	7500 pF $\pm 5\%$ , 500 V	1042269

Reference Designator	Description	Part Number
C40	18000 pF $\pm$ 5%, 500 V	1042271
C41, C60	15000 pF $\pm$ 5%, 500 V	1042272
C42	1500 pF $\pm$ 5%, 100 V	1042273
C54, C81, C104	.47 $\mu$ F $\pm$ 20%, 50 V	1042250
C63	22 pF $\pm$ 5%, 100 V	1042293
C59, C66, C67, C69, C76, C77, C85, C100, C101	CAP CER 0.1 $\mu$ F 100 V 10% X7S SMD 0603	1078183
C73	33 pF $\pm$ 5%, 100 V	1042307
C107	1000 pF $\pm$ 5%, 100 V	1042257
C105, C108	.047 $\mu$ F $\pm$ 20%, 50 V	1042247
C119, C126, C129	6800 pF $\pm$ 5%, 100 V	1042326
C150, C151, C158, C159	3900 pF $\pm$ 5%, 500 V	1042309
C152	3300 pF $\pm$ 5%, 500 V	1042306
C154, C157	.0047 $\mu$ F $\pm$ 10%, 2000 V	1042244
C155, C169	.68 $\mu$ F, 100 V	1042251
C171	10 $\mu$ F $\pm$ 20%, 25 V	1042266
C174	470 pF $\pm$ 5%, 100 V	1042314
C111, C112, C175, C176, C177, C178, C179, C180, C185	CAP MICA 30 PF 100 V 5% SMD 0805	1078179
C68	CAP CER 22 PF 100 V 5% COG SMD 0603	1078284
C75	CAP CER 33 PF 100 V 5% NPO SMD 0603	1078285

<b>Reference Designator</b>	<b>Description</b>	<b>Part Number</b>
C79	CAP CER 1000 PF 100 V 5% COG 0603	1078286
<b>Diodes</b>		
CR1	1N4007	1042283
CR3, CR4, CR5, CR6, CR7, CR8, CR12, CR15, CR25, CR26, CR27, CR28, CR34, CR37, CR39, CR41	1N4148	1042284
CR9	LED, GREEN, 2 DIA.	1041644
CR14, CR16, CR29	SCHOTTKY 0.6 A, 40 V	1042365
CR20, CR21, CR22, CR24, CR32, CR36, CR38, CR40, CR51	ZENER 1N5240B, 10 V	1042286
CR33, CR42, CR44, CR45, CR46, CR52	ZENER 1N5233B	1042285
CR17, CR18, CR47, CR48, CR49, CR50	DIODE SWITCH 100 V 0.15 A SOD 123	1078289
<b>Fuses</b>		
F1, F2, F3	FUSE, SUB-MINI 1/2 A	1049716
F4	FUSE, 5 x 20 mm, 6.3 A	1042348
<b>Relays</b>		
K1, K3, K4, K5, K6, K8, K9, K10, K11	12 V	1042361
K2	6-POLE	1042362

Reference Designator	Description	Part Number
K7	RELAY	1042364
K12, K13, K14, K15, K16, K17	COTO-9442	1042363
<b>Transistors</b>		
Q2	FET N-CH 14 A, 60 V	1042979
Q6, Q8, Q9, Q10	FET TN2404KL	1042981
<b>Resistors</b>		
R1, R2	9.1 K $\Omega$ , 1 W	1042332
R3, R38, R69	1 M $\Omega$ $\pm$ 5%, 1/4 W	1042282
R4	18.2 K $\Omega$ $\pm$ 1%, 1/8 W	1042276
R5, R6	30 K $\Omega$ $\pm$ 5%, 3 W	1042305
R7	91 K $\Omega$ $\pm$ 5%, 1/4 W	1042333
R8, R169	390 $\Omega$ $\pm$ 5%, 1/4 W	1042235
R9	10 $\Omega$ $\pm$ 5%, 1 W	1042255
R10	63.4 K $\Omega$ $\pm$ 1%, 1/4 W	1042325
R11, R17, R20, R25, R39, R75, R79, R92, R101, R106, R170	1 K $\Omega$ $\pm$ 5%, 1/4 W	1042278
R12, R18, R21, R26, R131, R136, R140	51 $\Omega$ $\pm$ 5%, 1/4 W	1042233
R74, R81, R87, R180, R181	RES 0603 1.00 K $\Omega$ 1% SMD	1078294

Reference Designator	Description	Part Number
R13, R14, R15, R45, R48, R67, R86, R91, R93, R99, R100, R107, R108, R111, R112, R122, R130, R132, R133, R134, R137, R142, R143, R173	10 K $\Omega \pm 5\%$ , 1/4 W	1042262
R16	4.75 K $\Omega \pm 1\%$ , 1/8 W	1042312
R19, R109	Thermistor, 10 K $\Omega$ , 25 C	1042265
R22, R23	10 $\Omega \pm 5\%$ , 1/2 W	1042254
R24, R34, R102, R117, R135	100 $\Omega \pm 5\%$ , 1/4 W	1041640
R27	267 $\Omega \pm 1\%$ , 1/8 W	1042296
R28, R54, R118, R119, R171	4.7 K $\Omega \pm 5\%$ , 1/4 W	1042313
R29, R127	3.32 K $\Omega \pm 1\%$ , 1/4 W	1042301
R30	1.3 K $\Omega \pm 5\%$ , 1/4 W	1042252
R32, R33	Thermistor	1042367
R35, R52	100 K $\Omega \pm 1\%$ , 1/8 W	1042259
R36	12.4 K $\Omega \pm 1\%$ , 1/8 W	1042268
R37	10 $\Omega \pm 5\%$ , 1/4 W	1042231
R40	7.5 $\Omega \pm 5\%$ , 1/2 W	1042330

Reference Designator	Description	Part Number
R121, R182, R183, R184, R185, R187, R188, R189, R190, R191, R192, R193, R194, R195, R196	RES THICK FILM 0603 100 $\Omega$ 1% SMD	1078166
R70, R125, R126, R128	RES 0603 4.70 K $\Omega$ 1% SMD	1078292
R41	649 $\Omega \pm 1\%$ , 1/8 W	1042279
R42, R55, R151, R156, R158, R162, R163, R165	10 K $\Omega \pm 1\%$ , 1/4 W	1042263
R95	RES 0603 10.0 K $\Omega$ 1% SMD	1078300
R43, R104	68 K $\Omega \pm 5\%$ , 1/4 W	1042329
R44	5.6 M $\Omega \pm 5\%$ , 1/4 W	1042319
R46	330 $\Omega \pm 5\%$ , 1/4 W	1042234
R47	1.6 K $\Omega \pm 5\%$ , 1/4 W	1042253
R49, R53	2.67 K $\Omega \pm 1\%$ , 1/8 W	1042290
R50	511 $\Omega \pm 1\%$ , 1/2 W	1042321
R56	200 K $\Omega \pm 5\%$ , 1/4 W	1042291
R57, R66	110 K $\Omega \pm 5\%$ , 1/4 W	1042267
R58	39 K $\Omega \pm 5\%$ , 1/2 W	1042310
R59, R60, R63, R65	2 K $\Omega \pm 1\%$ , 1/8 W	1042298
R61, R64	1 K $\Omega \pm 1\%$ , 1/8 W	1042280
R62	499 $\Omega \pm 1\%$ , 1/8 W	1042315
R68	510 $\Omega \pm 5\%$ , 1/4 W	1042236

Reference Designator	Description	Part Number
R76	100 $\Omega$ $\pm$ 1%, 2 W	1042256
R77	221 $\Omega$ $\pm$ 1%, 1/8 W	1042292
R78	280 $\Omega$ $\pm$ 1%, 1/4 W	1042297
R71, R72, R73, R85	RES 0603 2.00 $\Omega$ 1% SMD	1078293
R82	RES 0603 499 $\Omega$ 1% SMD	1078295
R80	62 K $\Omega$ $\pm$ 5%, 1/4 W	1042324
R83, R84	RES 0603 249 $\Omega$ 1% SMD	1078296
R88	RES 0603 6.80 K $\Omega$ 1% SMD	1078297
R89	RES 0603 5.10 K $\Omega$ 1% SMD	1078298
R90	RES 0603 3.92 K $\Omega$ 1% SMD	1078299
R94	56.2 K $\Omega$ $\pm$ 1%, 1/8 W	1042322
R96	TRIMPOT, 5 K $\Omega$	1042299
R97	RES 0603 301 $\Omega$ 1% SMD	1078302
R98	THERMISTOR, 1 K /25C 5%	1042281
R103	47 $\Omega$ $\pm$ 5%, 1/4 W	1042232
R105, R141	100 K $\Omega$ $\pm$ 5%, 1/4 W	1042258
R110	2.15 K $\Omega$ $\pm$ 1%, 1/8 W	1042289
R113, R114, R115,	820 $\Omega$ $\pm$ 5%, 1/4 W	1042238
R120	3.40 K $\Omega$ $\pm$ 1%, 1/8 W	1042303
R123	270 K $\Omega$ $\pm$ 5%, 1/4 W	1041641
R124, R144, R146, R147, R152, R155	750 $\Omega$ $\pm$ 5%, 1/4 W	1042237
R139	93.1 K $\Omega$ $\pm$ 1%, 1/4 W	1063247

Reference Designator	Description	Part Number
R138	15.0 K $\Omega$ $\pm$ 1%, 1/4 W	1042274
R145, R154, R157, R161, R167	5.11 K $\Omega$ $\pm$ 1%, 1/8 W	1042317
R148, R149	10 K $\Omega$ $\pm$ 1%, 10 W	1042264
R186	RES 0603 10.0 $\Omega$ 1% SMD	1078303
R116, R129, R172, R174, R175, R176, R177, R178, R179	VARISTOR 24 V 0603	1078180
R150, R153, R159, R166, R168	4.32 K $\Omega$ $\pm$ 1%, 1/8 W	1042311
R160, R164	5.6 M $\Omega$ $\pm$ 10%, 2 W	1042320
<b>Transformers</b>		
T1	PULSE, DUAL	1049710
T2, T6, T8, T16, T17	INDUCTOR, CURRENT SENSE	1042984
T3	POWER SWITCHING	1049709
T4	RF, MOLDED 3F3 CORE	1049713
T7, T10, T11, T12	SQUARE CORE, REM	1051726
T13	VOLTAGE SENSE	1049711
T14, T15	RF CHOKE	1049704
<b>Integrated Circuits</b>		
U32-U34	DIFF COMPARATOR QUAD 14 SOIC	1049744
U1	AVS1AC	1042976
U2, U9, U20, U26	LM 393 N	1042353

<b>Reference Designator</b>	<b>Description</b>	<b>Part Number</b>
U3, U13, U19	MOSFET DRIVER TSC1427	1042239
U4	MOSFET DRIVER	1042355
U5	PWM CONTROLLER, HIGH SPEED	1049749
U6	QUAD 2 INPUT 4093B	1042241
U7	OP-AMP MAX 492CPA	1042354
U8, U10, U11, U12, U23	DUAL OP-AMP AD827	1042334
U14	MULTIVIBRATOR 74LS221	1042242
U15, U16	2803A	1041652
U18, U21	OP-AMP LF412	1042351
U24	LM319	1042352
U25, U31	OP-AMP TL052A	1042368
U28	QUAD ANALOG SWITCH	1049743
U29	4081	1042240
U30	IC HEX INV 74 HC14	1042331
U22	IC ANALOG MUX W/DIODES	1042346
<b>Miscellaneous</b>		
D1	THERMISTOR TRIAC AVS 12 CB	1042974
J1	PHONE JACK	1042360
J2	CONNECTOR 15 PIN R/A	1042343
J3	CONNECTOR 90 DEG PCB 9 PIN	1042344
J5	CONNECTOR HEADER VERT 20 POS .100 GOLD	1078290
J6	CONNECTOR PCB 5 CKT	1042357
J7	CONNECTOR PCB 6 CKT	1042358
J8	CONNECTOR PCB 7 CKT	1042366
J9	CONNECTOR PC EDGE	1042340

Reference Designator	Description	Part Number
J10	CONNECTOR PCB 8 CKT	1042359
J16	CONNECTOR PCB 4 CKT	1042338
J12	CONNECTOR PCB 3 CKT	1042356
J13	CONNECTOR 96 PIN	1042339
J15, J4	CONN-PC MALE	1042336
J17	CONNECTOR PCB 2 CKT	1042337
J18, J19	CONTACT MONOPOLAR	1051136
J20	BIPOLAR CONTACT SPRING	1049707
J21, J22, J23, J24, J25, J26, J27, J28	FUSE CLIP	1042983
J29, J30	CONN HEADER VERT 4 POS .100 TIN	1078291
FB1, FB2, FB3, FB4, FB5, FB6, FB7, FB8, FB9, FB10, FB11, FB12, FB13, FB14, FB15, FB16, FB17, FB18, FB19, FB20, FB21	FERRITE 3A 100 $\Omega$ 1206 SMD	1078178
L1	INDUCTOR, 0.75 MH	1049708
OPT1, OPT2, OPT3, OPT4, OPT5	OPTOISOLATOR, SINGLE	1049745
TP1, TP2, TP3, TP4, TP5, TP6, TP7, TP8, TP9, TP10, TP11, TP12, TP13, TP15, TP16, TP17, TP18, TP19	TEST POINT	1049705
U17	OSCILLATOR, PRECISION	1049736



Part No. 1082255

COVIDIEN, COVIDIEN with logo, and Covidien logo and Positive Results for Life are U.S. and internationally registered trademarks of Covidien AG. Other brands are trademarks of a Covidien company, <sup>TM\*</sup> brands are trademarks of their respective owner.

U.S. Patents 5,599,344; 5,628,745; 6,203,541.

© 2013 Covidien.

Made in USA. Printed in USA.

 Covidien llc, 15 Hampshire Street, Mansfield, MA 02048 USA.

 Covidien Ireland Limited,  
IDA Business & Technology Park, Tullamore.

[www.covidien.com](http://www.covidien.com)

1-303-530-2300 [T]

1-800-255-8522 [T]

REV 09/2014

**Rx**  
ONLY



**PCF**  
ME20

**CE**  
0086



**COVIDIEN**



Schematics Supplement

Force FX™

Electrosurgical Generator C



# Schematics Supplement

This supplement contains the assembly drawings and schematics for the printed circuit board assemblies listed below:

- Control Board
- Display Board
- Footswitch Board
- Power Supply/RF Board



# Control Board Layout

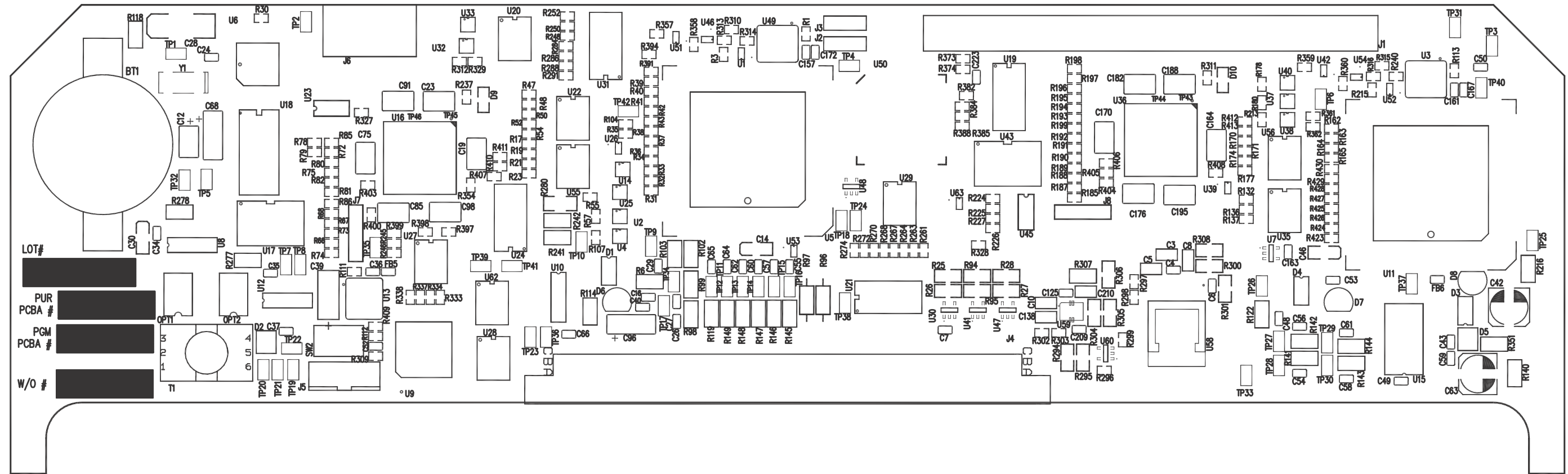

# Control Board Schematic - Sheet 1 of 4

SIGNAL CROSS-REFERENCE CHART					
SIGNAL	PRODUCT	FEZ	FX-C/FX-8C	FX-8CA	LIGASURE
M_P4_0 (U5)		REMPOT_INC\	SAME	SAME	SAME
M_P4_1 (U5)		REMPOT_U\D			▽
M_P4_2 (U5)		REMPOT_CSI\			
413_PA0 (U3)		CUT_LMP			MACRO_LMP
413_PA1 (U3)		COAG_LMP			SAME
413_PA2 (U3)		BIP_LMP			VS_LMP
413_PA3 (U3)		REM_GREEN			REGRASP
413_PA5 (U3)		BANK1			SMT_CNT1
413_PA6 (U3)		BANK2			SMT_CNT2
413_PA7 (U3)		REM_RED			UNUSED2
413_PB1 (U3)		_DPYB_WR			SAME
413_PB2 (U3)		_DPYC_WR			▽
413_PE2 (U3)		_UPTONE			_EMC_TONE
413_PE3 (U3)		_LGTONE			UNUSED1
413_PE4 (U3)		ALARM		▽	ALARM
413_PE5 (U3)		REM_EN		ABP_OFF	REGRASP0
413_PE6 (U3 & U11)		DOS_ERR\		SAME	HV_ENABLE
413_PE7 (U3)		ISO_TST			ISO_TST
412_PA0 (U6)		MON_RLY			SAME
412_PA1 (U6)		BIP_RLY			
412_PA2 (U6)		MONO2_RLY			
412_PA3 (U6)		MONO1_RLY			
412_PA4 (U6)		CUT_RLY			
412_PA5 (U6)		EKG_RLY			
412_PB0 (U6)		V_RLY_0			
412_PB1 (U6)		V_RLY_1			
412_PB2 (U6)		V_RLY_2			
412_PB3 (U6)		V_RLY_3			
412_PB4 (U6)		I_RLY_0			
412_PB5 (U6)		I_RLY_1			
412_PB6 (U6)		I_RLY_2			
412_PB7 (U6)		I_RLY_3			
412_PE3 (U6)		CAP_RLY	▽	▽	▽

# Control Board Schematic - Sheet 2 of 4

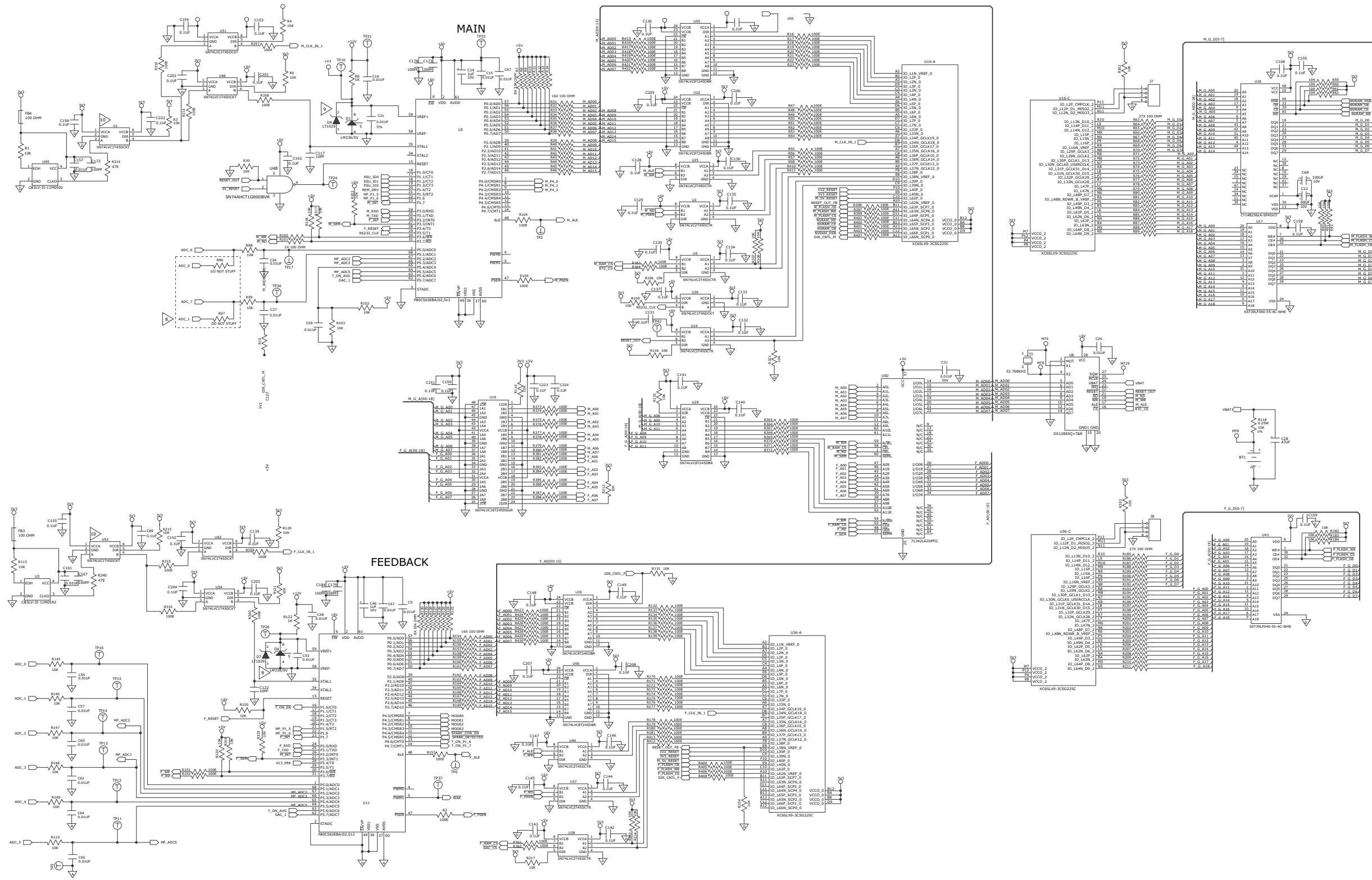



# Control Board Schematic - Sheet 4 of 4

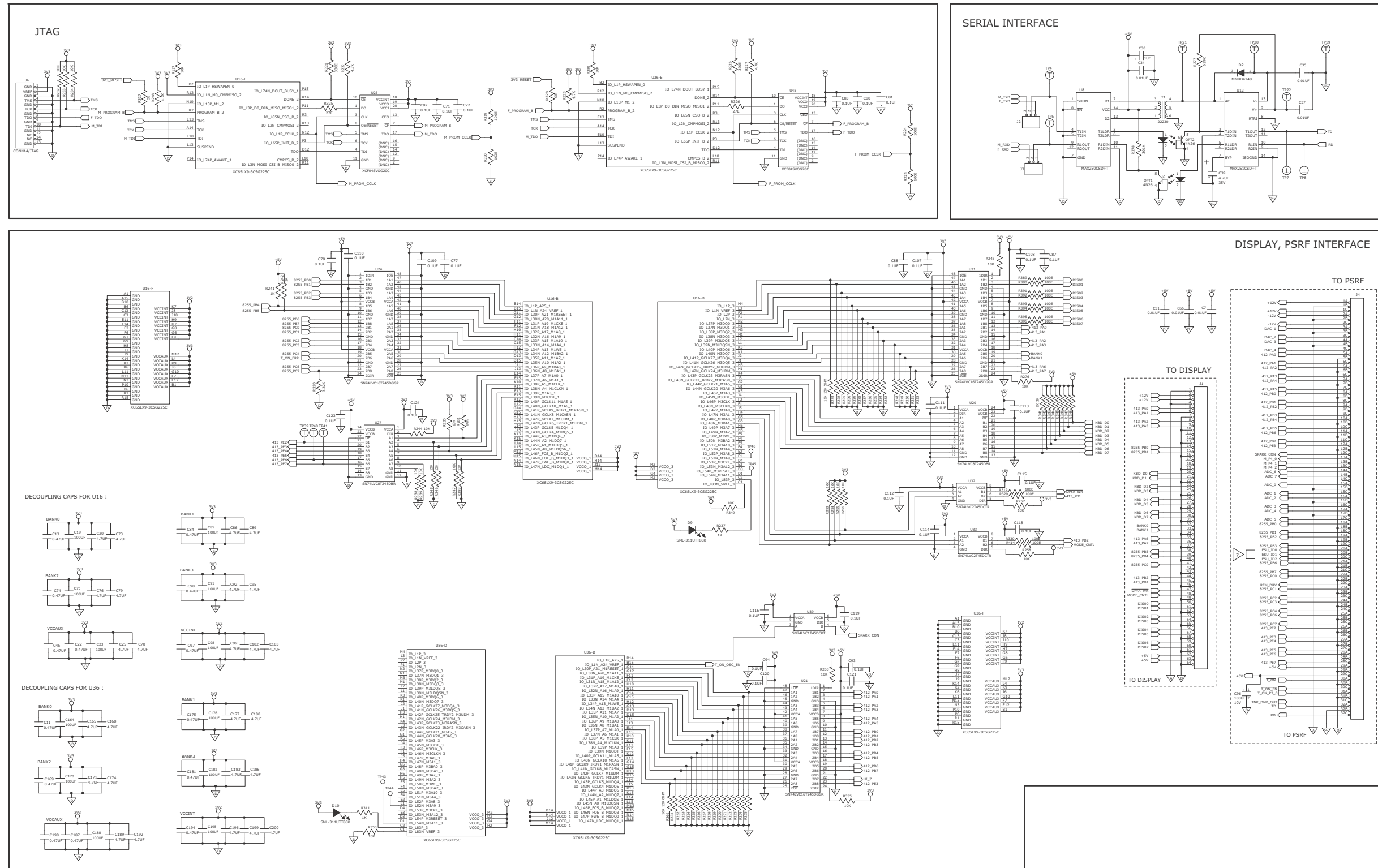

# Display Board Layout

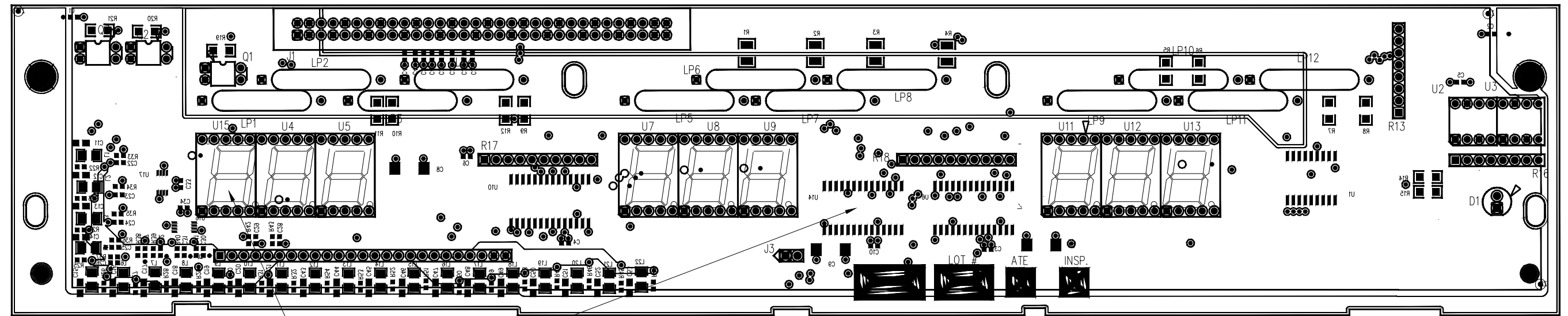

DON'T POPULATE U14 AND U15

# Display Board Schematic

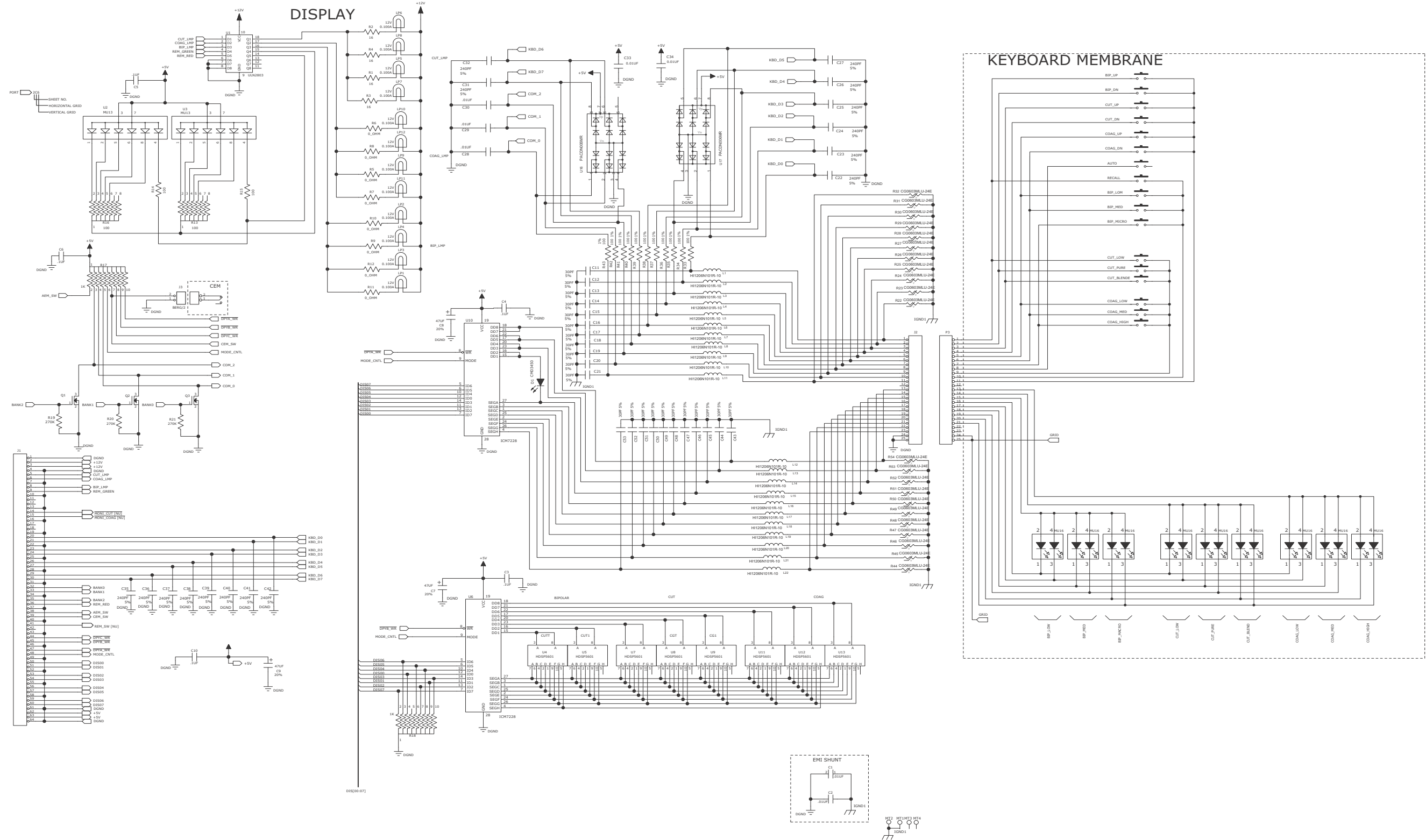

# Footswitch Board Layout

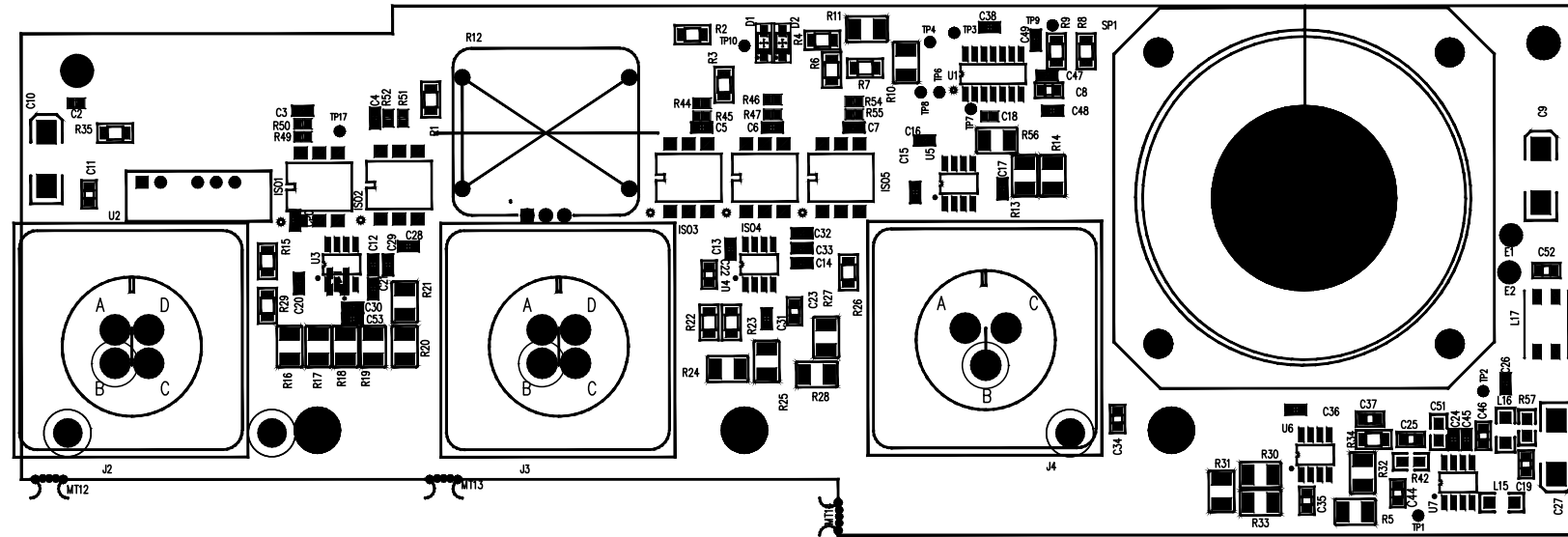

COMPONENT SIDE

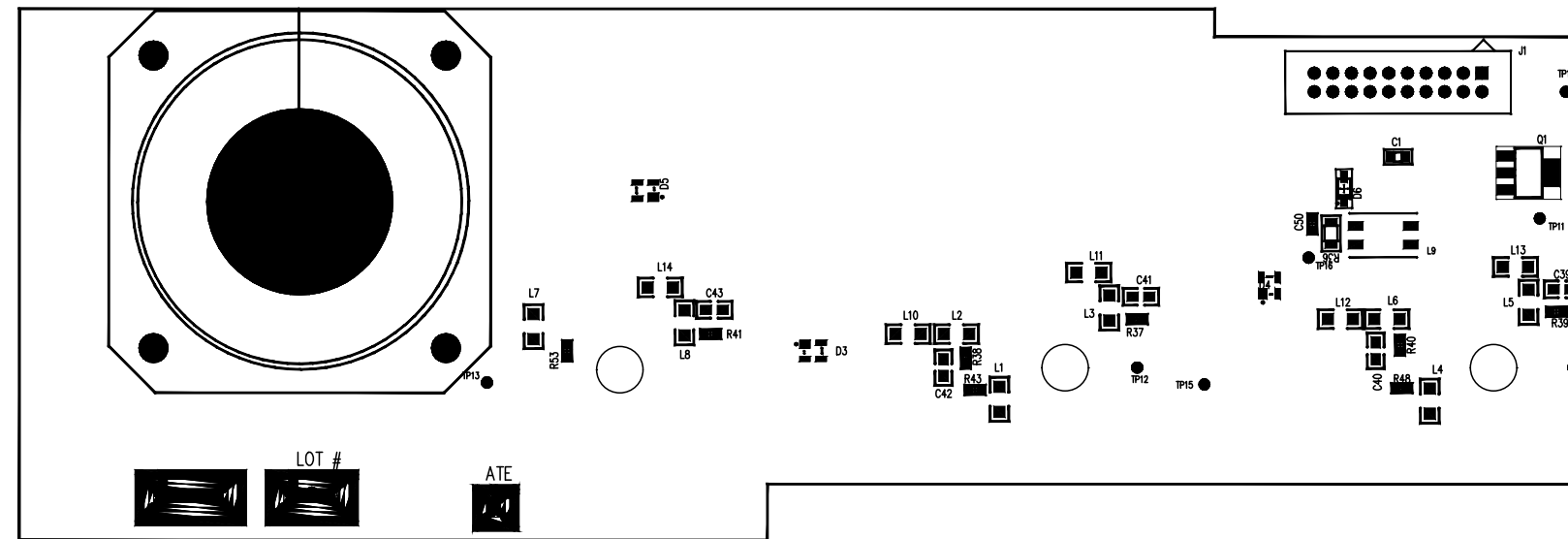

CIRCUIT SIDE

# Footswitch Board Schematic - Sheet 1 of 2

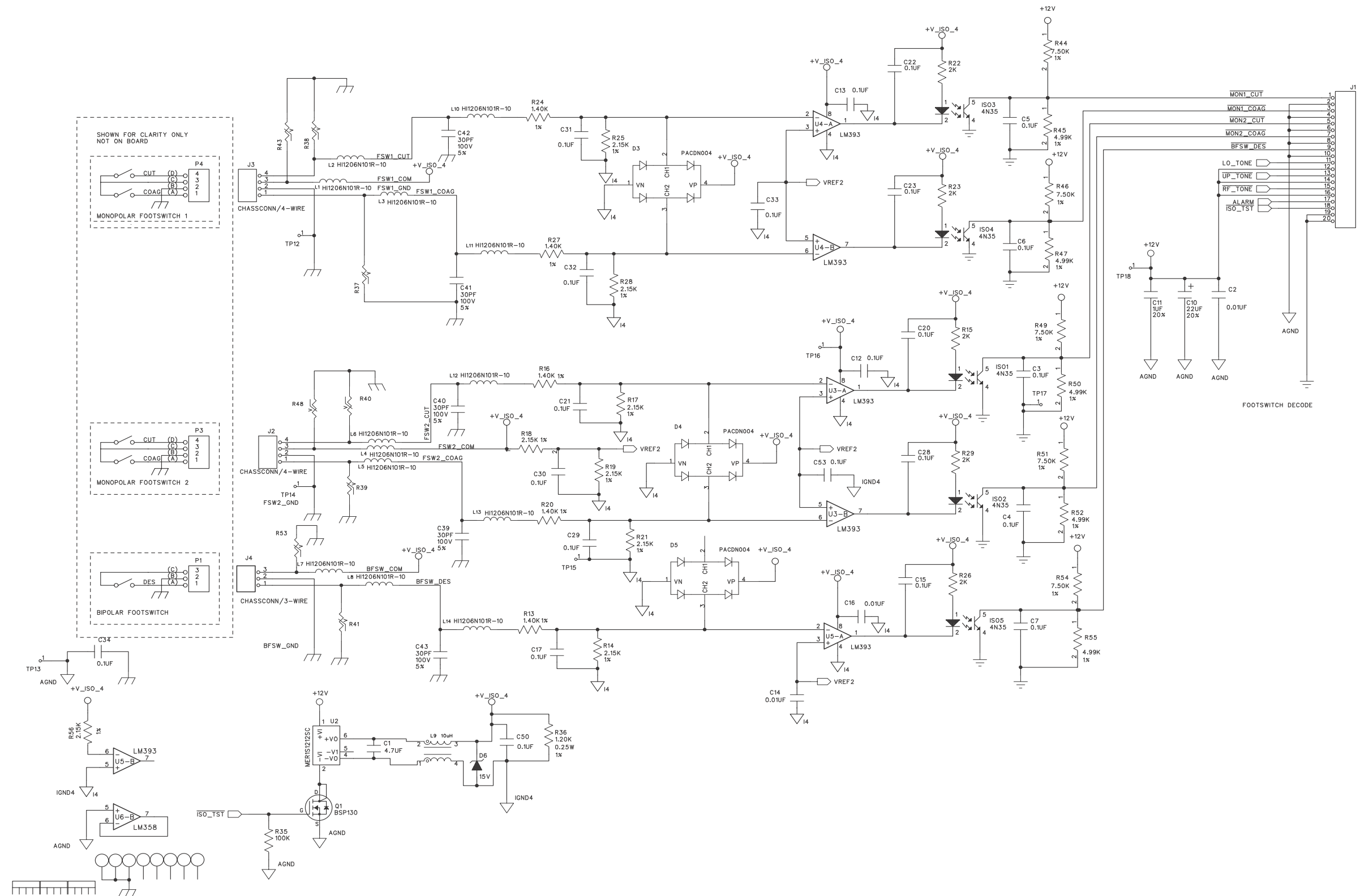

# Footswitch Board Schematic - Sheet 2 of 2

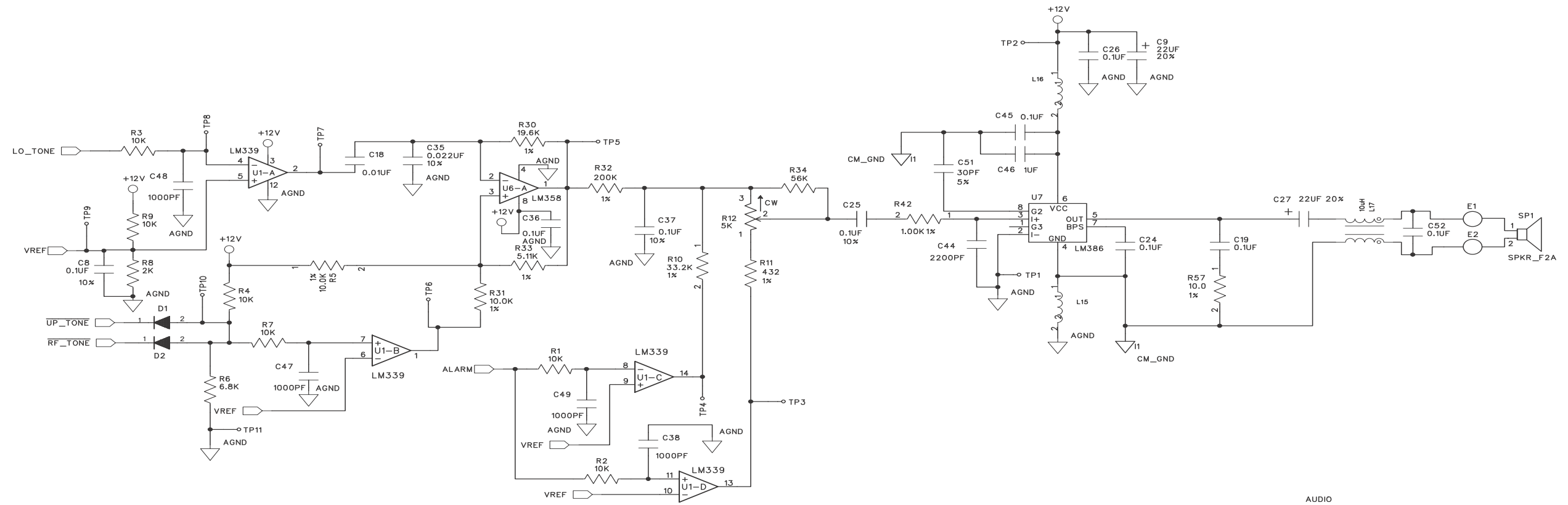

AUDIO

# Power Supply/RF Board Assembly

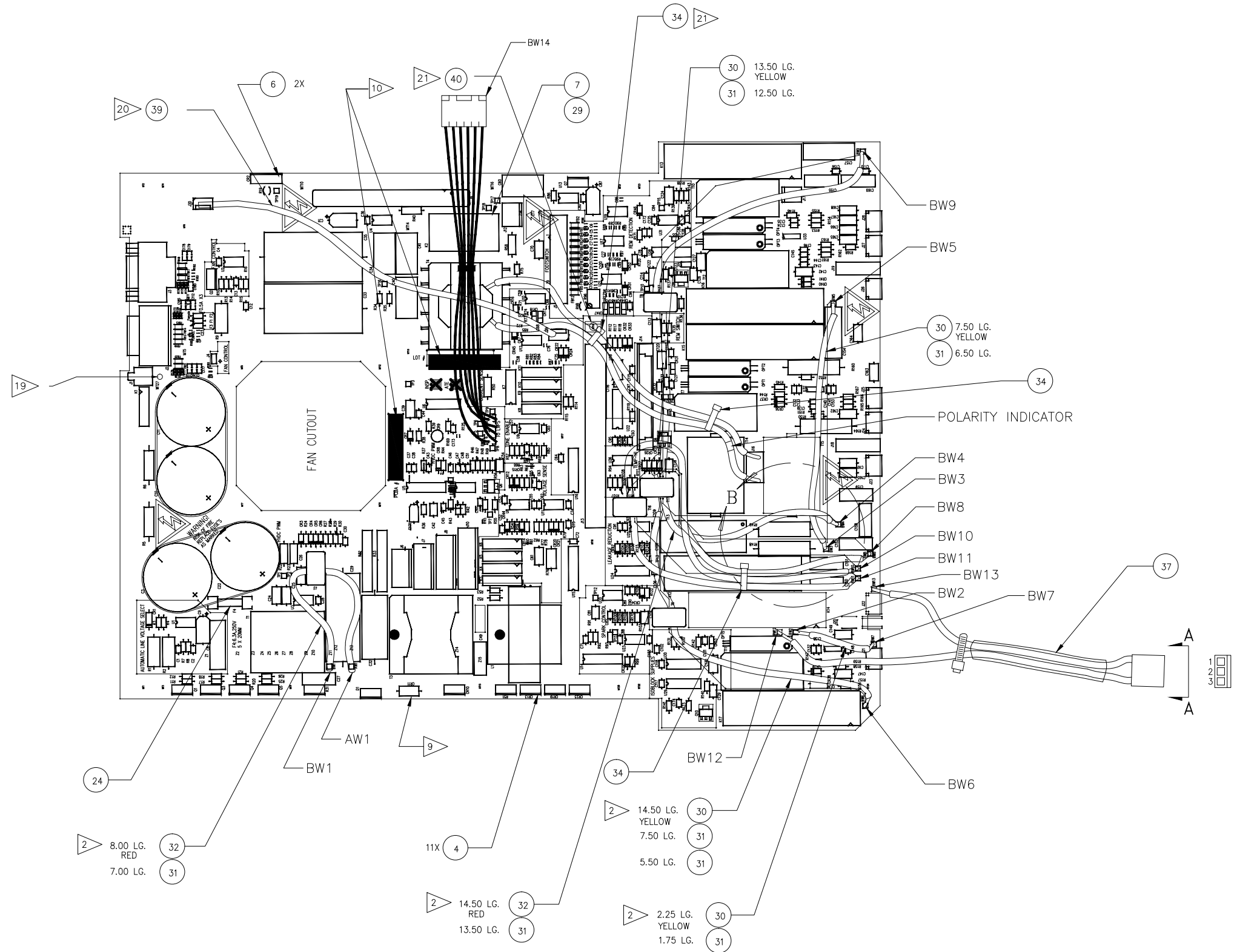

# Power Supply/RF Board Schematic - Sheet 1 of 2

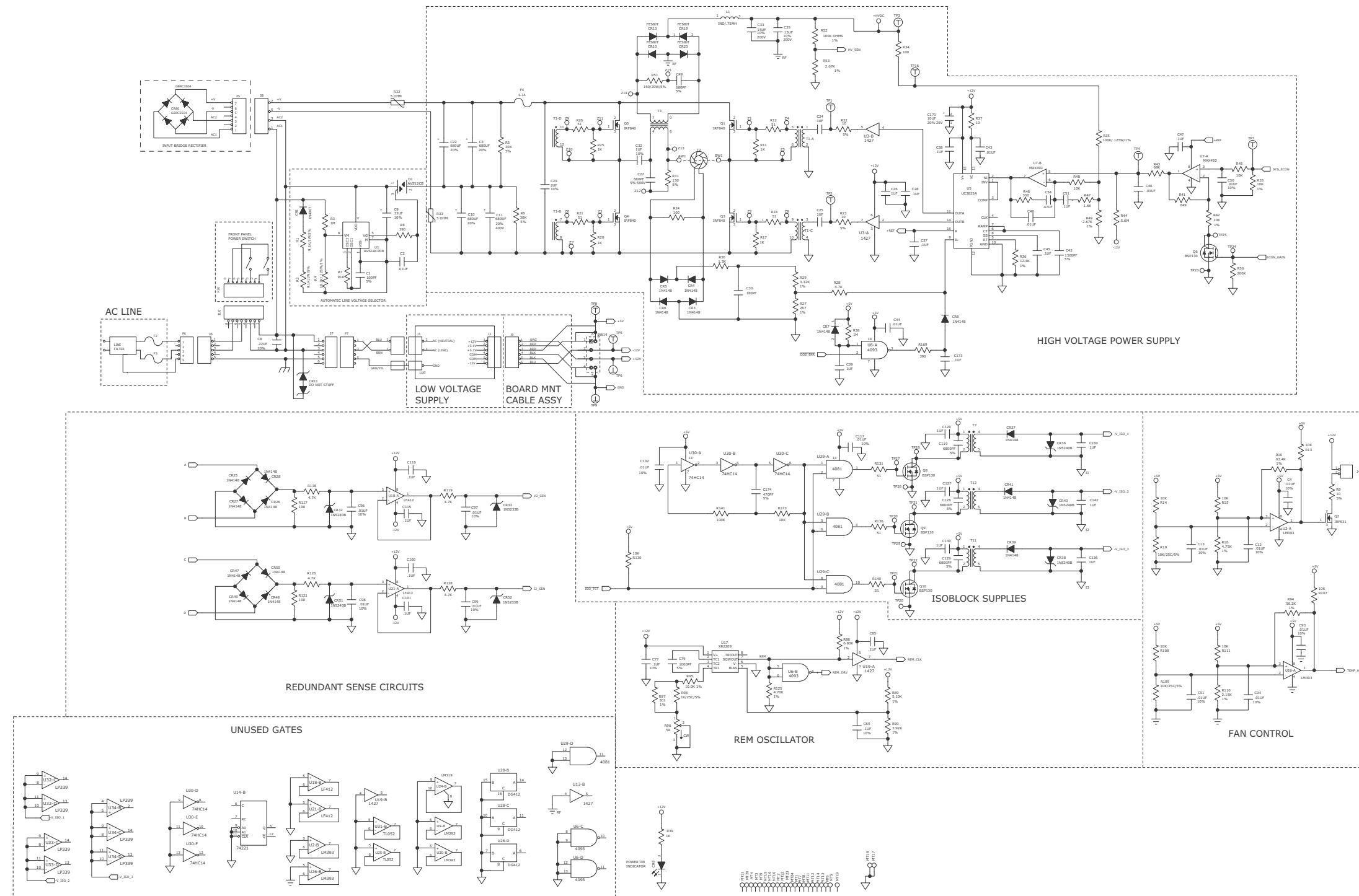

# Power Supply/RF Board Schematic - Sheet 2 of 2

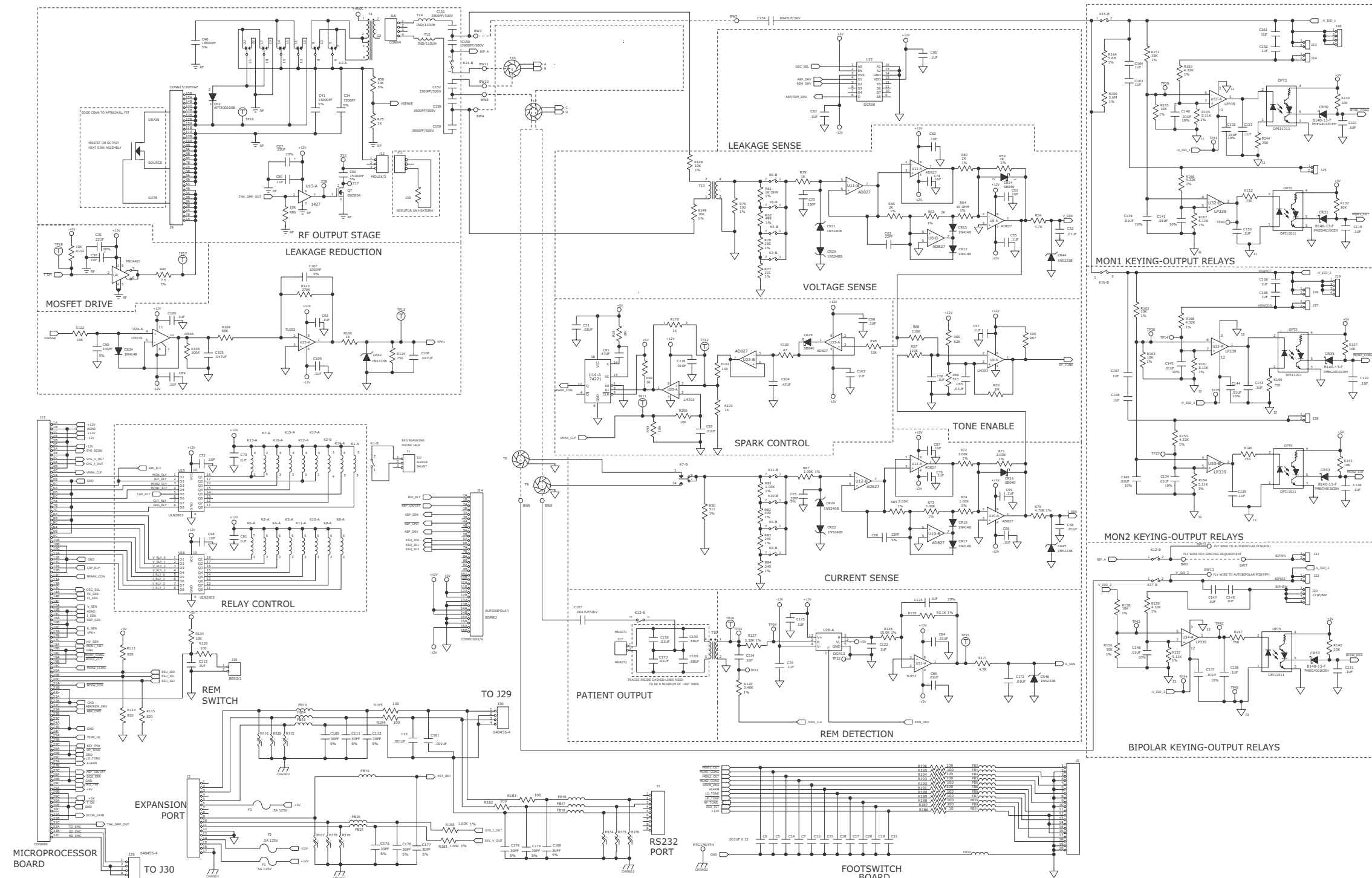

# Autobipolar Board Layout

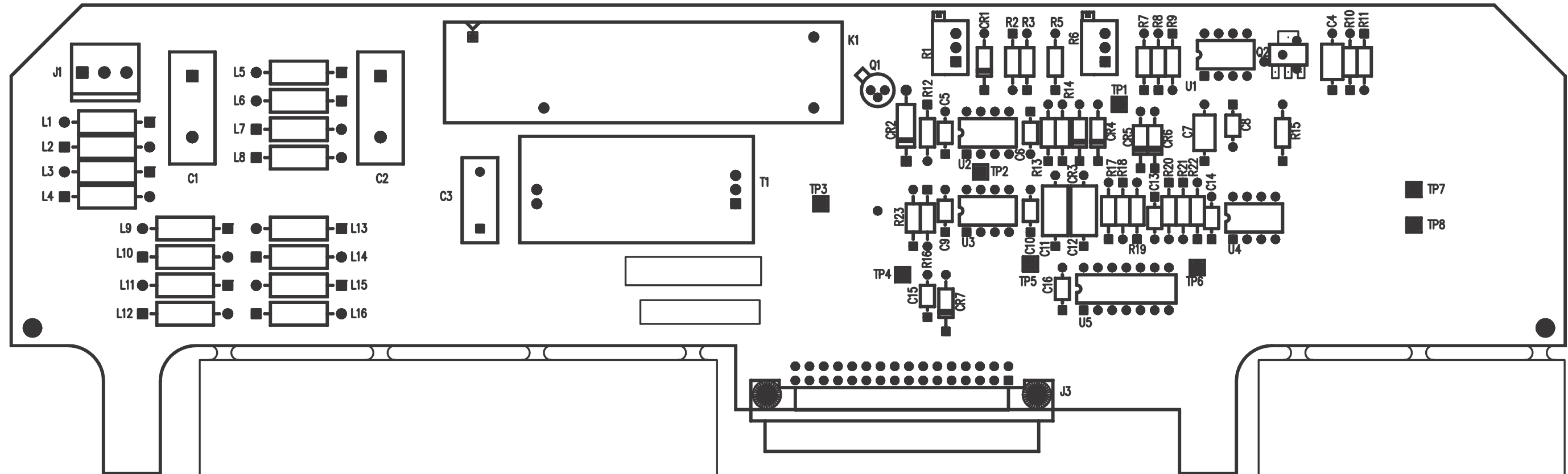

# Autobipolar Board Schematic - Sheet 1 of 2

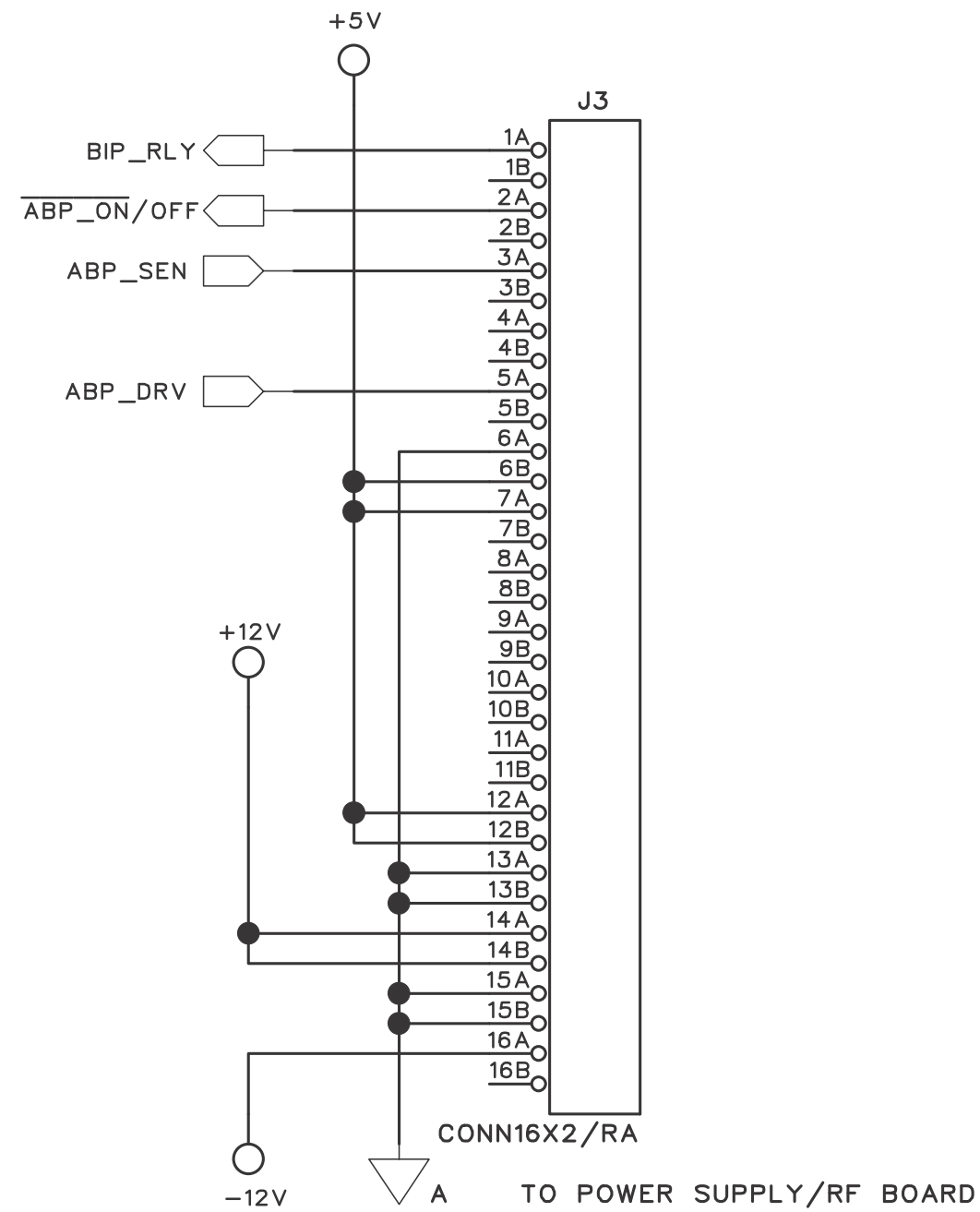

# Autobipolar Board Schematic - Sheet 2 of 2

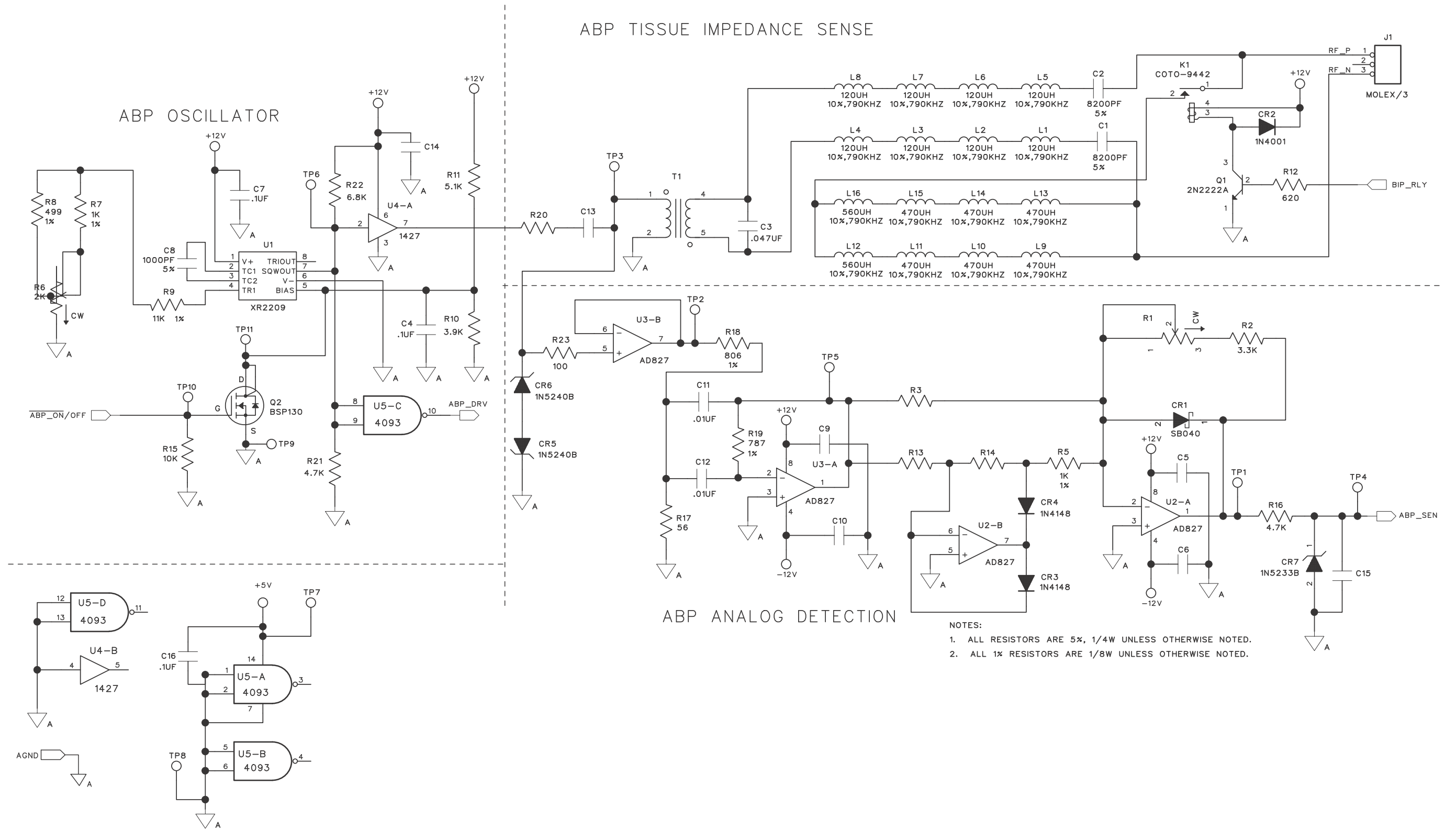



Part No. 1082255

COVIDIEN, COVIDIEN with logo, and Covidien logo and Positive Results for Life are U.S. and internationally registered trademarks of Covidien AG. Other brands are trademarks of a Covidien company, <sup>TM\*</sup> brands are trademarks of their respective owner.

U.S. Patents 5,599,344; 5,628,745; 6,203,541.

© 2013 Covidien.

Made in USA. Printed in USA.

 Covidien llc, 15 Hampshire Street, Mansfield, MA 02048 USA.

 Covidien Ireland Limited,  
IDA Business & Technology Park, Tullamore.

[www.covidien.com](http://www.covidien.com)

1-303-530-2300 [T]

1-800-255-8522 [T]

REV 09/2014

**Rx**  
ONLY



**PCF**  
ME20

**CE**  
0086



**COVIDIEN**