

Color Video Printer

Instructions for Use

CE

UP-55MD

Owner's Record

The model and serial numbers are located at the rear. Record these numbers in the space provided below. Refer to these numbers whenever you call upon your Sony dealer regarding this product.

Model No. _____

Serial No. _____

WARNING

To reduce the risk of fire or electric shock, do not expose this apparatus to rain or moisture.

To avoid electrical shock, do not open the cabinet. Refer servicing to qualified personnel only.

No modification of this equipment is allowed.

THIS APPARATUS MUST BE EARTHED.

To disconnect the main power, unplug the power plug.

When installing the unit, incorporate a readily accessible disconnect device in the fixed wiring, or connect the power plug to an easily accessible socket-outlet near the unit.

Do not position the ME equipment where it is difficult to unplug the power plug.

If a fault should occur during operation of the unit, operate the disconnect device to switch the power supply off, or unplug the power plug.

Symbols on the products



This symbol indicates the equipotential terminal which brings the various parts of a system to the same potential.



This symbol indicates the manufacturer, and appears next to the manufacturer's name and address.



Refer to the operating instructions

Follow the directions in the operating instructions for parts of the unit on which this mark appears.

For the customers in the U.S.A.

This equipment has been tested and found to comply with the limits for a Class A digital device, pursuant to Part 15 of the FCC Rules. These limits are designed to provide reasonable protection against harmful

interference when the equipment is operated in a commercial environment. This equipment generates, uses, and can radiate radio frequency energy and, if not installed and used in accordance with the instruction manual, may cause harmful interference to radio communications. Operation of this equipment in a residential area is likely to cause harmful interference in which case the user will be required to correct the interference at his own expense.

You are cautioned that any changes or modifications not expressly approved in this manual could void your authority to operate this equipment.

All interface cables used to connect peripherals must be shielded in order to comply with the limits for a digital device pursuant to Subpart B of Part 15 of FCC Rules.

For the State of California, USA only

Perchlorate Material - special handling may apply. See www.dtsc.ca.gov/hazardouswaste/perchlorate
Perchlorate Material : Lithium battery contains perchlorate.

For the customers in Canada

This unit has been certified according to Standard CAN/CSA-C22.2 No.60601-1.

For the customers in the U.S.A and Canada

When you use this product connected to 240 V single phase, be sure to connect this product to a center tapped circuit.

Important safeguards/notices for use in the medical environments

1. All the equipments connected to this unit shall be certified according to Standard IEC60601-1, IEC60950-1, IEC60065 or other IEC/ISO Standards applicable to the equipments.
2. Furthermore all configurations shall comply with the system standard IEC60601-1-1. Everybody who connects additional equipment to the signal input part or signal output part configures a medical system, and is therefore, responsible that the system complies with the requirements of the system standard IEC60601-1-1. If in doubt, consult the qualified service personnel.
3. The leakage current could increase when connected to other equipment.
4. For this particular equipment, all accessory equipment connected as noted above, must be connected to mains via an additional isolation

transformer conforming with the construction requirements of IEC60601-1 and providing at least Basic Insulation.

- 5. This equipment generates, uses, and can radiate radio frequency energy. If it is not installed and used in accordance with the instruction manual, it may cause interference to other equipment. If this unit causes

interference (which can be determined by unplugging the power cord from the unit), try these measures: Relocate the unit with respect to the susceptible equipment. Plug this unit and the susceptible equipment into different branch circuit.

Consult your dealer. (According to standard IEC60601-1-2 and CISPR11, Class B, Group 1)

Important EMC notices for use in the medical environments

- The UP-55MD needs special precautions regarding EMC and needs to be installed and put into service according to the EMC information provided in this instructions for use.
- The portable and mobile RF communications equipment such as cellular phones can affect the UP-55MD.

Warning

The use of accessories and cables other than those specified, with the exception of replacement parts sold by Sony Corporation, may result in increased emissions or decreased immunity of the UP-55MD.

Guidance and manufacturer's declaration-electromagnetic emissions		
The UP-55MD is intended for use in the electromagnetic environment specified below. The customer or the user of the UP-55MD should assure that it is used in such an environment.		
Emission test	Compliance	Electromagnetic environment-guidance
RF emissions CISPR 11	Group 1	The UP-55MD uses RF energy only for its internal function. Therefore, its RF emissions are very low and are not likely to cause any interference in nearby electronic equipment. The UP-55MD is suitable for use in all establishments, including domestic establishments and those directly connected to the public low-voltage power supply network that supplies buildings used for domestic purposes.
RF emissions CISPR 11	Class B	
Harmonic emissions IEC 61000-3-2	Class A	
Voltage fluctuations/ flicker emissions IEC 61000-3-3	Complies	

Warning

If the UP-55MD should be used adjacent to or stacked with other equipment, it should be observed to verify normal operation in the configuration in which it will be used.

Guidance and manufacturer's declaration - electromagnetic immunity

The UP-55MD is intended for use in the electromagnetic environment specified below. The customer or the user of the UP-55MD should assure that it is used in such as environment.

Immunity test	IEC 60601 test level	Compliance level	Electromagnetic environment-guidance
Electrostatic discharge (ESD) IEC 61000-4-2	±6 kV contact ±8 kV air	±6 kV contact ±8 kV air	Floors should be wood, concrete or ceramic tile. If floors are covered with synthetic material, the relative humidity should be at least 30%.
Electrical fast transient/burst IEC 61000-4-4	±2 kV for power supply lines ±1 kV for input/output lines	±2 kV for power supply lines ±1 kV for input/output lines	Mains power quality should be that of a typical commercial or hospital environment.
Surge IEC 61000-4-5	±1 kV differential mode ±2 kV common mode	±1 kV differential mode ±2 kV common mode	Mains power quality should be that of a typical commercial or hospital environment.
Voltage dips, short interruptions and voltage variations on power supply input lines IEC 61000-4-11	< 5% U_T (> 95% dip in U_T) for 0.5 cycle 40% U_T (60% dip in U_T) for 5 cycles 70% U_T (30% dip in U_T) for 25 cycles < 5% U_T (> 95% dip in U_T) for 5 sec	< 5% U_T (> 95% dip in U_T) for 0.5 cycle 40% U_T (60% dip in U_T) for 5 cycles 70% U_T (30% dip in U_T) for 25 cycles < 5% U_T (> 95% dip in U_T) for 5 sec	Mains power quality should be that of a typical commercial or hospital environment. If the user of the UP-55MD requires continued operation during power mains interruptions, it is recommended that the UP-55MD be powered from an uninterruptible power supply or a battery.
Power frequency (50/60 Hz) magnetic field IEC 61000-4-8	3 A/m	3 A/m	Power frequency magnetic fields should be at least characteristic of a typical location in a typical commercial or hospital environment.

NOTE: U_T is the a.c. mains voltage prior to application of the test level.

Guidance and manufacturer's declaration - electromagnetic immunity

The UP-55MD is intended for use in the electromagnetic environment specified below. The customer or the user of the UP-55MD should assure that it is used in such as environment.

Immunity test	IEC 60601 test level	Compliance level	Electromagnetic environment-guidance
Conducted RF IEC 61000-4-6	3 Vrms 150 kHz to 80 MHz	3 Vrms	<p>Portable and mobile RF communications equipment should be used no closer to any part of the UP-55MD, including cables, than the recommended separation distance calculated from the equation appliance to the frequency of the transmitter.</p> <p>Recommended separation distance</p> $d = 1.2 \sqrt{P}$
Radiated RF IEC 61000-4-3	3 V/m 80 MHz to 2.5 GHz	3 V/m	$d = 1.2 \sqrt{P} \quad 80 \text{ MHz to } 800 \text{ MHz}$ $d = 2.3 \sqrt{P} \quad 800 \text{ MHz to } 2.5 \text{ GHz}$ <p>Where P is the maximum output power rating of the transmitter in watts (W) according to the transmitter manufacturer and d is the recommended separation distance in meters (m).</p> <p>Field strengths from fixed RF transmitters, as determined by an electromagnetic site survey, ^a should be less than the compliance level in each frequency range. ^b</p> <p>Interference may occur in the vicinity of equipment marked with following symbol:</p> 

NOTE 1: At 80 MHz and 800 MHz, the higher frequency range applies.

NOTE 2: These guidelines may not apply in all situations. Electromagnetic propagation is affected by absorption and reflection from structures, objects and people.

a Field strengths from fixed transmitters, such as base stations for radio (cellular/cordless) telephones and land mobile radios, amateur radio, AM and FM radio broadcast and TV broadcast cannot be predicted theoretically with accuracy. To assess the electromagnetic environment due to fixed RF transmitters, an electromagnetic site survey should be considered. If the measured field strength in the location in which the UP-55MD is used exceeds the applicable RF compliance level above, the UP-55MD should be observed to verify normal operation. If abnormal performance is observed, additional measures may be necessary, such as reorienting or relocating the UP-55MD.

b Over the frequency range 150 kHz to 80 MHz, field strengths should be less than 3 V/m.

Recommended separation distances between portable and mobile RF communications equipment and the UP-55MD

The UP-55MD is intended for use in an electromagnetic environment in which radiated RF disturbances are controlled. The customer or the user of the UP-55MD can help prevent electromagnetic interference by maintaining a minimum distance between portable and mobile RF communications equipment (Transmitters) and the UP-55MD as recommended below, according to the maximum output power of the communications equipment.

Rated maximum output power of transmitter W	Separation distance according to frequency of transmitter m		
	150 kHz to 80 MHz $d = 1.2 \sqrt{P}$	80 MHz to 800 MHz $d = 1.2 \sqrt{P}$	800 MHz to 2.5 GHz $d = 2.3 \sqrt{P}$
0.01	0.12	0.12	0.23
0.1	0.38	0.38	0.73
1	1.2	1.2	2.3
10	3.8	3.8	7.3
100	12	12	23

For transmitters rated a maximum output power not listed above, the recommended separation distance d in meters (m) can be estimated using the equation applicable to the frequency of the transmitter, where P is the maximum output power rating of the transmitter in watts (W) according to the transmitter manufacturer.

NOTE 1: At 80 MHz and 800 MHz, the separation distance for the higher frequency range applies.

NOTE 2: These guidelines may not apply in all situations. Electromagnetic propagation is affected by absorption and reflection from structures, objects and people.

Caution

When you dispose of the unit or accessories, you must obey the law in the relative area or country and the regulation in the relative hospital.

Warning on power connection

- Use a proper power cord for your local power supply.
1. Use the approved Power Cord (3-core mains lead) / Appliance Connector / Plug with earthing-contacts that conforms to the safety regulations of each country if applicable.
 2. Use the Power Cord (3-core mains lead) / Appliance Connector / Plug conforming to the proper ratings (Voltage, Ampere).

If you have questions on the use of the above Power Cord / Appliance Connector / Plug, please consult a qualified service personnel.

Warning on power connection for medical use

Please use the following power supply cord. With connectors (plug or female) and cord types other than those indicated in this table, use the power supply cord that is approved for use in your area.

	United States and Canada
Plug Type	HOSPITAL GRADE*
Cord Type	Min.Type SJT Min.18 AWG
Minimum Rating for Plug and Appliance Couplers	10 A/125 V
Safety Approval	UL Listed and CSA

*Note: Grounding reliability can only be achieved when the equipment is connected to an equivalent receptacle marked 'Hospital Only' or 'Hospital Grade'.

For the customers in Europe

This product has been manufactured by or on behalf of Sony Corporation, 1-7-1 Konan Minato-ku Tokyo, 108-0075 Japan. Inquiries related to product compliance based on European Union legislation shall be addressed to the authorized representative, Sony Deutschland GmbH, Hedelfinger Strasse 61, 70327 Stuttgart, Germany.

For any service or guarantee matters, please refer to the addresses provided in the separate service or guarantee documents.

For the customers in Taiwan only



廢電池請回收

Table of Contents

Introduction

System Overview	8
Location and Function of Parts and Controls	8
Front Panel	8
Rear Panel	10
Monitor Display	10

Preparation

Supplied Accessories	12
Connections	12
Connecting Video Equipment	12
Connecting the Video Monitor	13
Making Connections to Enable Remote Control	14
Before Printing	14
Loading an Ink Ribbon Cartridge	14
Inserting the Paper Tray/Loading Paper	17
Selecting the Input Signal	19
Setting Date and Time	20

Operation

Making Full-Size Image Printouts	22
Making Printouts with the Desired User Set Number	24
Making Multiple Copies of Identical Printouts	26
Capturing Another Image While Printing	28
Making Variations of Printouts	29
Selecting the Memory Mode	29
Selecting a Memory Page	30
Making a Printout of Multiple Different Reduced Images	31
Making Printouts With Date or a Caption	36
Making Printouts With a Caption	36
Entering a Caption	37
Making Printouts with a Date	40
Deleting Images Stored in Memory	41
Setting the Function of the CLEAR Button	41
Deleting Images Stored in Memory	41
Erasing the Screen Display on the Video Monitor	43
Storing Image Data on a USB Flash Memory Device	44
Storing Image Data on a USB Flash Memory Device	44
Selecting the Printer Operation When the USB Flash Memory Device Becomes Full	45
Making Printouts with File Names	46

Adjustment

Functions That Can be Set on Menus	47
Menu Tree	48
Basic Menu Operations	49
Adjusting the Color and Picture Quality	52
Compensating for the Input Signals	52
Matching the Video Monitor Color to the Printer Color	52
Adjusting the Printout Color	53
When a Black Frame or Lines Show up on the Printouts	56
Fitting the Printout to the Paper	57
Adjusting the Color Balance	57
Making Various Settings	60
Assigning Functions to the Remote Control Unit	60
Adjusting the Brightness of the Printer Window Display	62
Selecting Whether the Operation and Error Tones Sound	62
Setting the Baud Rate	62
Displaying the Remaining Amount of the Ink Ribbon	62
Registering a User Set	62

Miscellaneous

Precaution	64
Safety	64
Installation	64
Before Transporting the Printer	64
Cleaning	64
Ink Ribbon and Paper	65
Specifications	65
Error/Warning Messages	67
Error Messages	67
Warning Messages	68
Troubleshooting	69
If Damage is Suspected	69
If the Paper Jams	70
Index	73

System Overview

The UP-55MD is a color video printer that quickly and easily reproduces images from video equipment such as a VTR.

The UP-55MD has the following features:

- High picture quality and high print resolution
The printer allows you to print out high resolution images in full color (with 256 shades per color, a total of more than 16,700,000 colors in all) in high resolution print mode (approximately 379 dpi).
- Menu settings to meet your printer's specifications
By changing the menu settings for the printer, you can make various types of printouts. You can also add a caption to the printout. You can carry out ordinary printer operations using the buttons on your printer and you can set up the printer interactively by choosing settings from displayed menus.
- USB host port
The printer is equipped with a USB host port so that you can store image data captured in the printer in the USB flash memory in the JPEG (Joint Photographic Experts Group) format. You can see the image data captured using a personal computer.







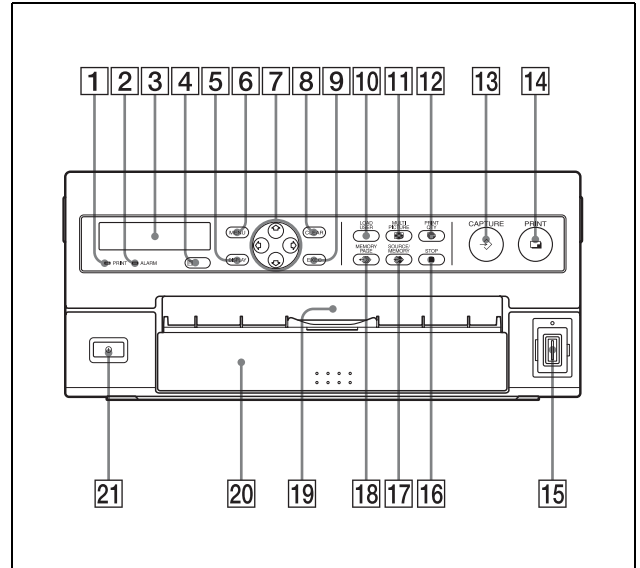

Location and Function of Parts and Controls

For details, refer to the pages given in parentheses.

Front Panel



- 1 PRINT indicator**
Lights while the printer is printing.
- 2 ALARM indicator (67)**
Lights in orange when the ink ribbon or paper is exhausted, the paper jams, or another problem occurs.
- 3 Printer window display**
Displays messages that also appear along the bottom edge of the monitor screen. The printer window display has a narrower display range and shows only a limited number of characters. Also displays the menu screen line at which the cursor is positioned. If an error occurs, a corresponding error message is displayed.
The contrast of the printer window display can be adjusted on the SYSTEM SETUP menu. (“Adjusting the Brightness of the Printer Window Display” on page 62.)
- 4 Remote sensor (14)**
Aim the head of the remote control unit toward this sensor.
- 5 DISPLAY button (24, 43)**
When the regular screen is displayed, pressing this button toggles the screen display of messages such as Q1, A, etc., on and off regardless of the setting of

- the DISPLAY item in the OUTPUT SETUP menu. The setting of DISPLAY in the OUTPUT SETUP menu changes linked with the press of this button. When the menu is displayed, pressing this button temporarily clears the menu display. While this button is held down, the menu display disappears.
- 6 MENU button**
Press this button to display or clear the menus.
- 7**  **(Cursor) keys**
Use to select a desired item from the menu. Also, these keys are used to position the cursor (green pointer) on the regular screen when capturing multiple reduced images.
- 8 CLEAR button (41, 42)**
Press this button to clear the images captured in the memory pages. Which images can be cleared with the CLEAR button depends on the setting made with the FUNCTION SETUP menu. When the clear function of this button is set to OFF, the buzzer sounds if you press the CLEAR button.
- 9 EXEC button**
Press this button to execute the values set with the COLOR ADJUST menu or to load a user set in the PRINTER SETUP menu and to register the user set in the SYSTEM SETUP menu. Also, this button is used to enter the characters of a caption in the CAPTION menu.
- 10 LOAD USER button**
Press this button to recall a registered user set.
- 11**  **MULTI PICTURE button (31)**
Press this button to select the desired printout type on the regular screen. When you press this button, the currently selected printout type is displayed for a few seconds. Each time you press this button, the type is switched in the following sequence: 1, 2, 4, 8, 1.... The setting of MULTI PIX on the LAYOUT SETUP menu changes linked with the press of this button.
- 12**  **PRINT QTY (quantity) button (26)**
Press this button to set the number of copies on the regular screen. You can set any number up to 10. When you press this button, the currently selected number is displayed for a few seconds. The setting of PRINT QTY on the PRINTER SETUP menu changes linked with the press of this button. You can change the number of copies currently printed even when the printer is printing.
- 13**  **CAPTURE button**
Press this button to capture an image in a memory page.
- 14**  **PRINT button**
Press this button to make a printout.
- 15 USB host port**
Insert the USB flash memory into this port.
- Note**
Be sure not to insert a USB flash memory manufactured by other manufactures other than Sony Corporation.
- 16**  **STOP button (23)**
Press this button to stop continuous printing. The printer stops printing after finishing the printing item currently being printed.
- 17**  **SOURCE/MEMORY button**
Press this button to select which signal is to be output to the monitor. The memory image and source image are toggled each time you press this button.
- 18**  **MEMORY PAGE button (28, 31, 42)**
Press to select the memory page.
- 19 Paper output slot**
Printed pages (printouts) are ejected here. Depending on the curled condition of printouts, the printer may stop printing and display the message "REMOVE PRINTS." In such a case, remove the printouts accumulated on the paper tray. The printer will start to print the remaining copies automatically.
- 20 Paper tray (12, 17)**
Load paper into this tray.
- 21**  **POWER switch**
Press this switch to turn the printer on or off.

Rear Panel

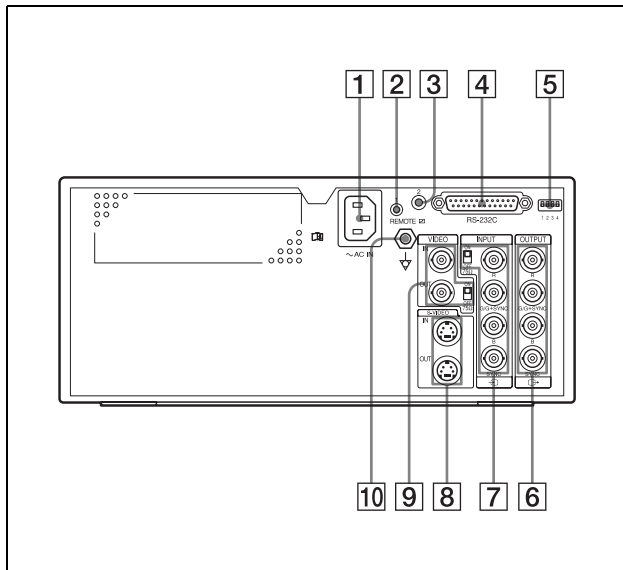

- 1** **~ AC IN connector (12, 13, 14)**
Use a proper power cord for your local power supply (not supplied).
Refer to “Warning on power connection” on page 6 and “Warning on power connection for medical use” on page 6.
- 2** **☑ REMOTE 1 connector (special mini jack) (14)**
Used to connect an RM-5500 Remote Control Unit (not supplied) to be used as a wired remote control unit.
- 3** **☑ REMOTE 2 connector (stereo mini jack) (14)**
Used to connect an RM-91 Remote Control Unit (not supplied) or an FS-24 Foot Switch (not supplied).
- 4** **RS-232C connector (14)**
Used to connect a computer to control the printer.
For details, contact your nearest Sony dealer.
- 5** **Dip switches**
Used to set the video signal system to select either NTSC or PAL video system.
When the dip switch 1 is set to the lower position, the NTSC video system is selected.
When the dip switch 1 is set to the upper position, the PAL video system is selected.

Note

To set the dip switch, turn the power off once, then change the setting. If you change the setting with the power on, this mode will not be switched.
- 6** **↔ OUTPUT (RGB/YCbCr/SYNC) connectors (12)**
Used to connect the video equipment with RGB/YCbCr input connectors.
- 7** **↔ INPUT (RGB/YCbCr/SYNC) connectors/75Ω termination ON/OFF switch (12)**
INPUT connector: Used to connect the video equipment with RGB/YCbCr output connectors.
75Ω ON/OFF switch: Normally set this switch to ON. Set it to OFF if the input signal should drop when you connect additional equipment to the video equipment.
- 8** **S-VIDEO IN/S-VIDEO OUT (S-video signal input/S-video signal output) connectors (12, 13)**
S-VIDEO IN connector: Used to connect to the video equipment with Y/C separated output connector.
S-VIDEO OUT connector: Used to connect to the video equipment with Y/C separated INPUT connector.
- 9** **VIDEO IN/VIDEO OUT connectors (Composite video signal input/composite video signal output)//75Ω termination ON/OFF switch (12, 13)**
VIDEO IN connector: Used to connect to the video equipment with a composite video signal output connector.
VIDEO OUT connector: Used to connect to the video equipment with a composite video signal input connector.
75Ω ON/OFF switch: Normally set this switch to ON. Set it to OFF if the input signal should drop when you connect additional equipment to the video equipment.
- 10** **⚡ Equipotential ground terminal connector**
Used to connect to the equipotential plug to bring the various parts of a system to the same potential.
Refer to “Important safeguards/notices for use in the medical environments” on page 2.

Monitor Display

When the printer is connected to the video monitor and you first turn on the printer, the following regular screen message appears.
When the MENU button is pressed, the menu screen displayed.

For detailed information on the menu screen, see “Menu Tree” on page 48.

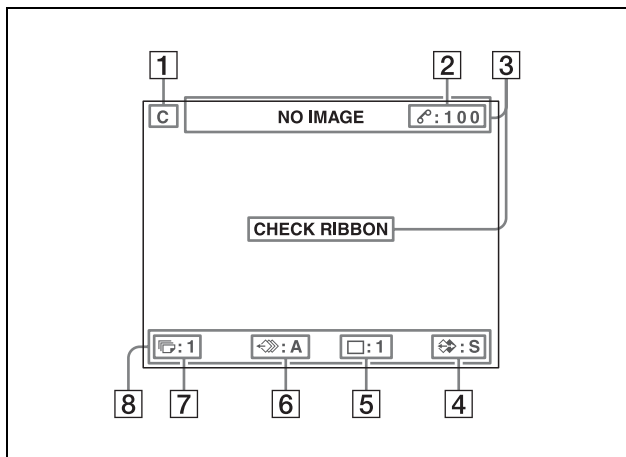

- 1 C (caption)/F (file name) display section**
C is displayed when the printer is set to print a caption.
F is displayed when the printer is set to print a file name.
- 2 Remaining amount of ink ribbon display section**
Displays the remaining amount of ribbon (indicates the number of printouts that can still be made with the ribbon).
- 3 Message display section**
Messages are displayed.
Usually messages are displayed on the top line of the screen.
Urgent messages are displayed on the center of the screen.
- 4 S or M (image type) display section**
Indicates the type of image being displayed on the monitor screen.
S (Source): The image from the input signal source is displayed on the screen.
M (Memory): The image captured in memory is displayed on the screen.
- 5 Printer operation mode display section**
Indicates the printer operation mode (type of printouts such as multiple reduced images).

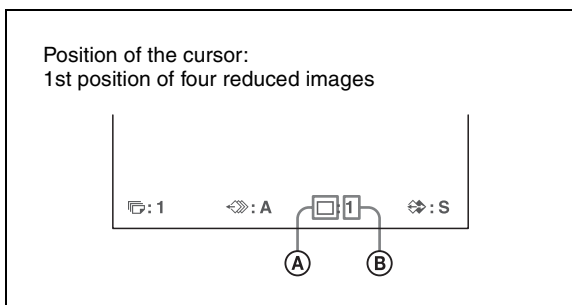

- A Type of printout**
Indicates the type of printout.

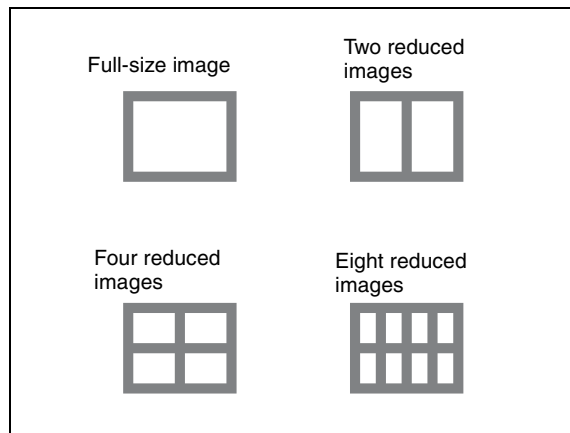

When SEPARATE (image with white borders) is set to ON on the LAYOUT SETUP menu, the borders are displayed on the screen.

- B Position of the cursor**
Indicates the position where the cursor is currently placed and where an image will be captured.
- 6 Memory page display section**
Indicates the currently selected memory page.
While the image in the memory page is being printed, the memory page indication blinks. The memory page whose memory image is queued to be printed blinks.
- 7 Q (print quantity) display**
Indicates the number of copies to be printed. This item blinks while the printer is busy.
- 8 Printer setting status display section**
The corresponding currently selected status is displayed when either MULTI PICTURE or PRINT QTY button is pressed.

Supplied Accessories

The printer is packed together with the following accessories. Check that nothing is missing from your package.

Paper tray (1)



Ink ribbon holder (1)

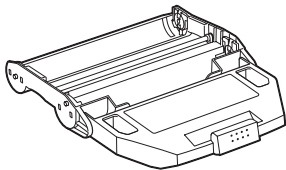

CD-ROM (1)
Before Using this Printer (1)
Instructions for Use (1)
Service Contact List (1)

Notes

- Retain the original carton and packing materials in case you have to transport the unit in the future.
- Remove the ink ribbon cartridge and paper tray when transporting the printer.

Connections

To enable printing, video equipment to act as an input signal source, and a video monitor to display images or menus must be connected.

The following diagrams illustrate how to make the input, output and remote control connections. Use this as a guide when connecting the cables required to transmit signals to and from the equipment to be used for printing.

Notes

- Turn off the power of each device before attempting to make any connections.
- Connect the AC power cord last.

Connecting Video Equipment

Connect the video equipment providing the video images to be printed.

Connect the video equipment which will be used in actual printing, using the following diagram as a guide. Before connecting the video equipment, see “Important safeguards/notices for use in the medical environments” on page 2.

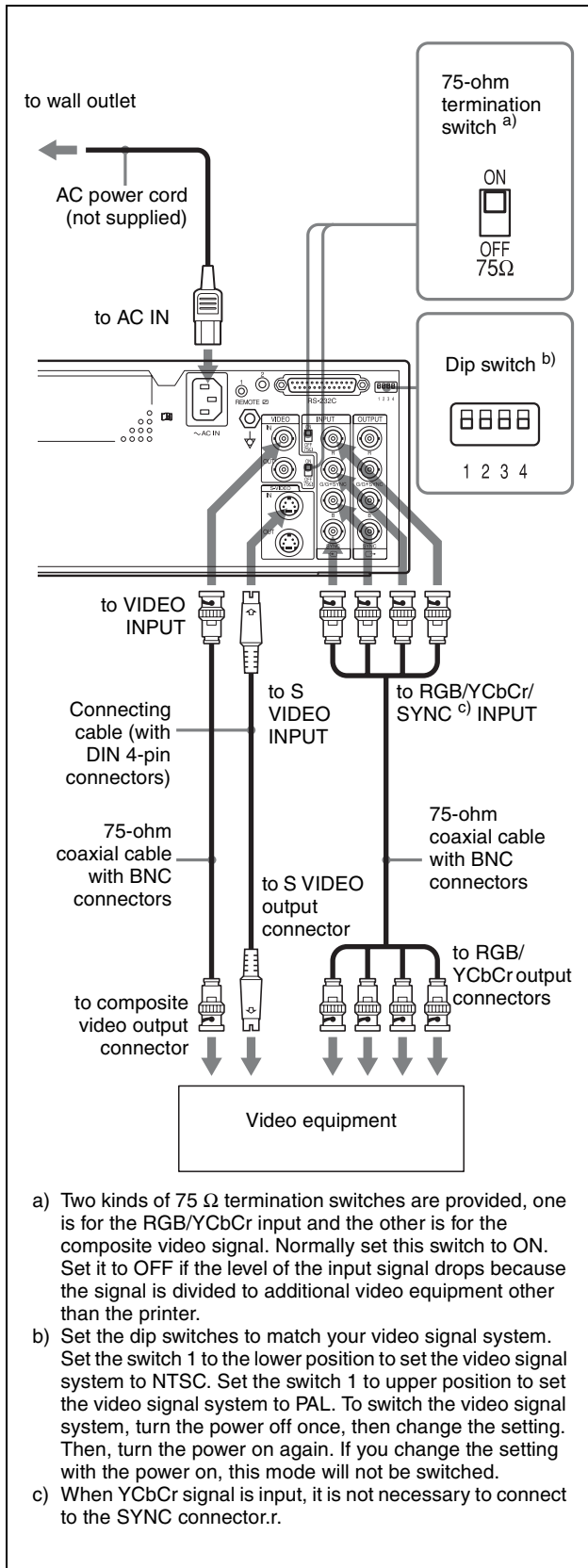

Connecting the Video Monitor

Connect a video monitor to view captured images and to check those to be printed. Connect a suitable video

monitor which will be used in actual printing, using the following diagram as a guide.

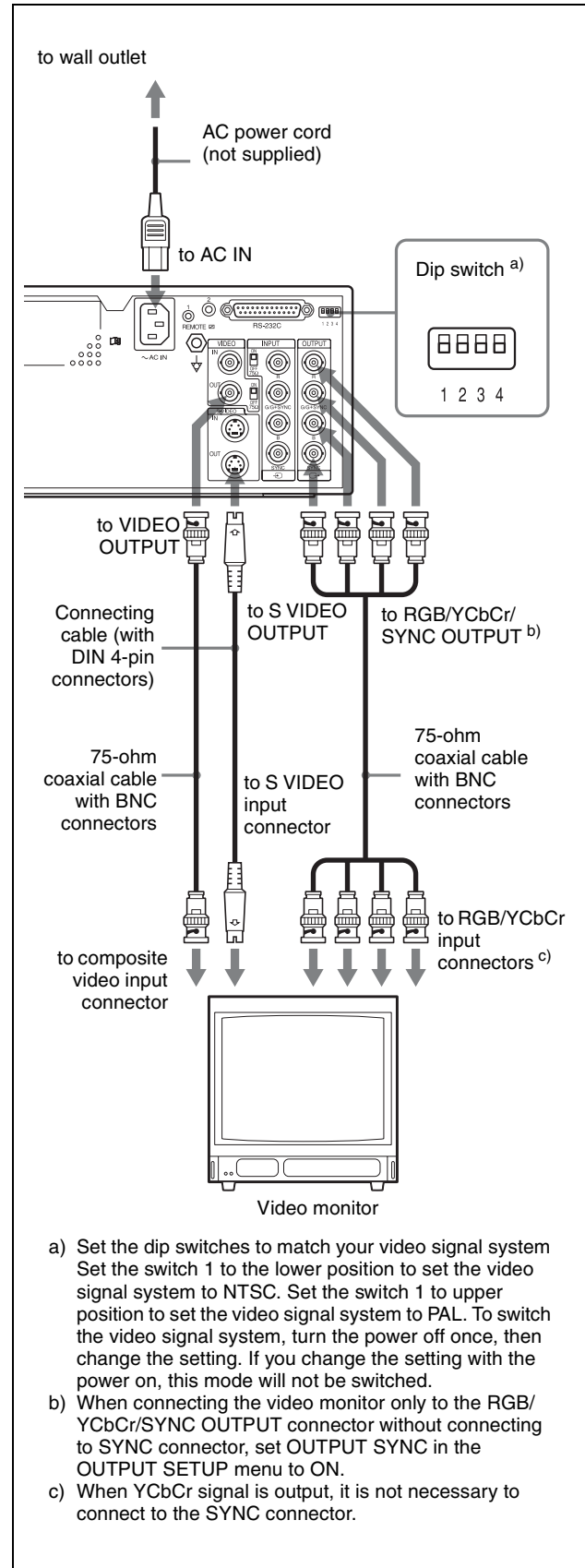

Making Connections to Enable Remote Control

The printer can be controlled remotely by connecting an RM-5500 Remote Control Unit (not supplied), an RM-91 Remote Control Unit (not supplied), an FS-24 Foot Switch (not supplied), or a personal computer.

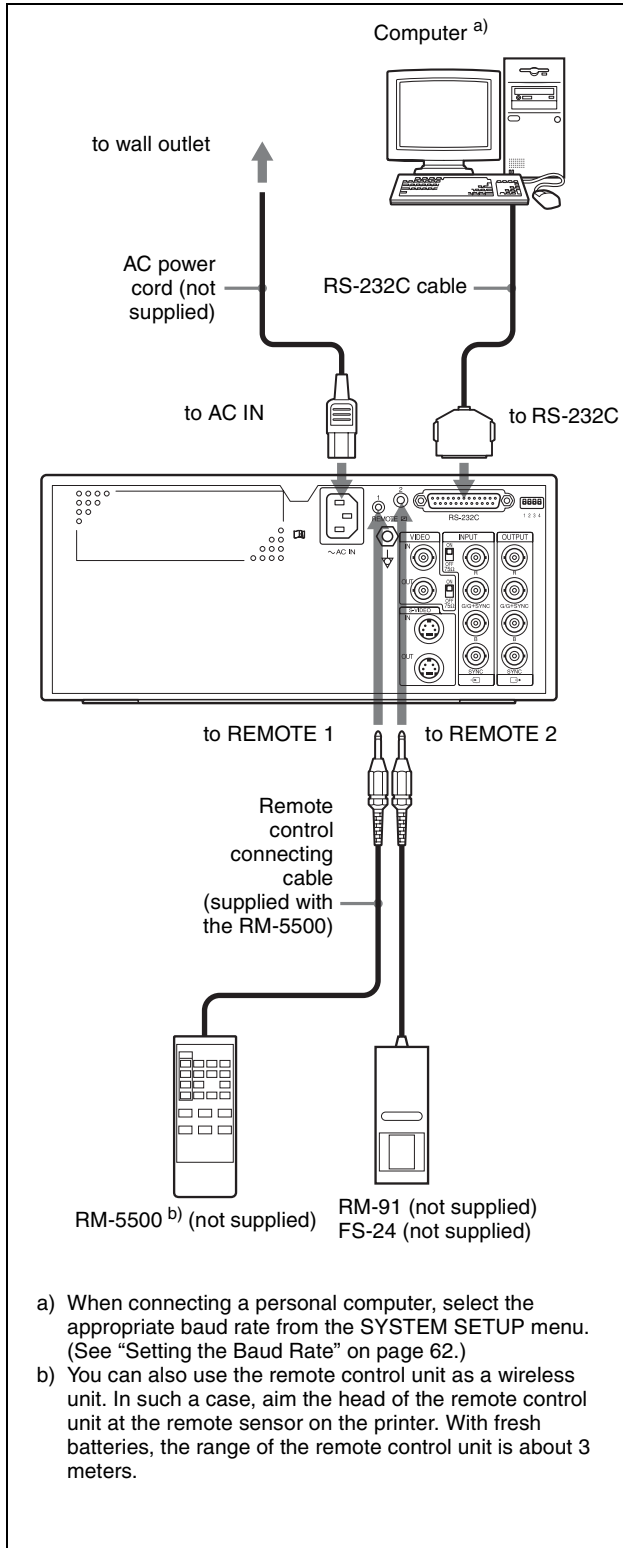

Before Printing

Before printing, but after mounting the paper tray on the printer and making the necessary connections (see "Connections" on page 12), perform the following as preparation.

- Loading an ink ribbon (See below.)
- Loading paper (See page 17.)
- Selecting the input signal (See page 19.)
- Setting the date and time (See page 20.)

Notes

- Use the ink ribbon and paper contained in the same package as a pair. Before attempting to load an ink ribbon or paper, make sure that the combination of the ink ribbon and paper is compatible.
- When either an ink ribbon or paper has been exhausted, replace both the ink ribbon and paper at the same time.
- Use only ink ribbon and paper designed for use with this printer. Failing to do so is likely to result in malfunctions. (See "Ink Ribbon and Paper" on page 65.)

Loading an Ink Ribbon Cartridge

To make printouts, an ink ribbon cartridge (an ink ribbon holder which has been loaded with an ink ribbon) and paper must be loaded. This section describes how to set the ink ribbon into the supplied ink ribbon holder and to load the ink ribbon cartridge in the printer.

When you use the printer for the first time, start the operation to load the ink ribbon cartridge from step 4.

Notes

- **When you use the printer for the first time, the thermal head may be out of position. Before attempting to load the ink ribbon cartridge, turn on the power under the condition where the front door is closed so that the thermal head is placed at the correct position.**
- If a blank sheet of paper is ejected, and the message "RIBBON END" appears, the ink ribbon has been exhausted. Replace the paper together with the ink ribbon. Do not reuse the ejected blank paper.
- Once an ink ribbon has been completely used up, replace it. An ink ribbon is not reusable.
- Do not rewind the ink ribbon for reuse.
- Do not touch the ink ribbon or place it in a dusty location. Finger prints or dust on the ink ribbon will result in imperfect printing or malfunction of the head.

- 1** Open the front door by pulling the front door toward you.

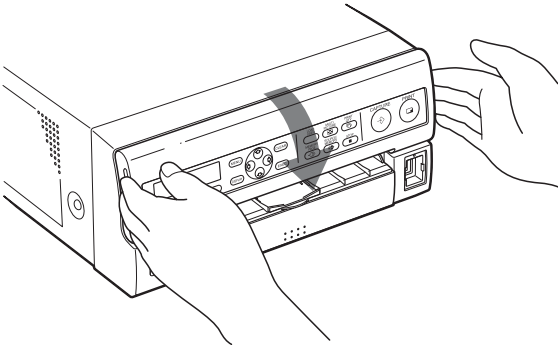

- 2** Remove the ink ribbon cartridge.

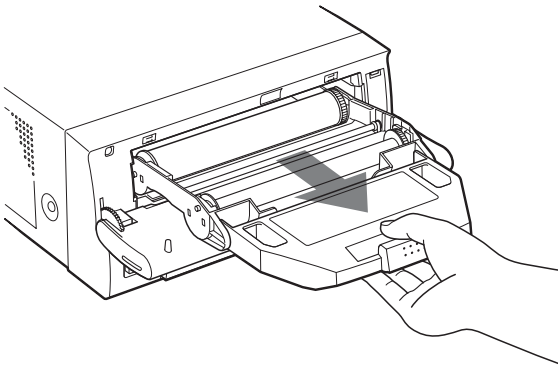

If you can not remove the ink ribbon cartridge

The thermal head may be out of position. In such a case, close the front door, and turn the power off, then back on again. After a while, start the operation from step 1 again.

- 3** Detach the spent ink ribbon from the ink ribbon holder.

Pushing the ink ribbon spool that takes up the ink ribbon in the direction of the arrow, remove the spool from the side with the gray gear.

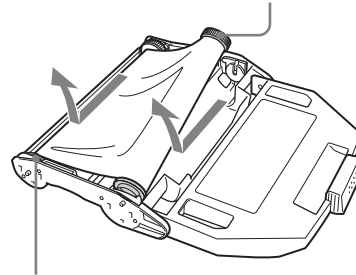

Pushing the ink ribbon spool that sends the ink ribbon in the direction of the arrow, remove the spool from the side with the white gear.

- 4** Load the new ink ribbon into the ink ribbon holder.

- ① Holding the ink ribbon firmly, remove the gear cover.

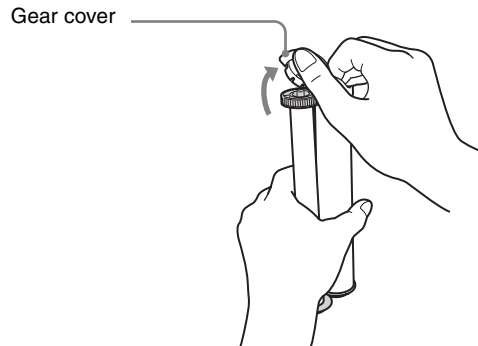

To avoid dropping the ink ribbon, make sure that you hold it firmly.

- ② Place the ink ribbon with the white gear as illustrated.

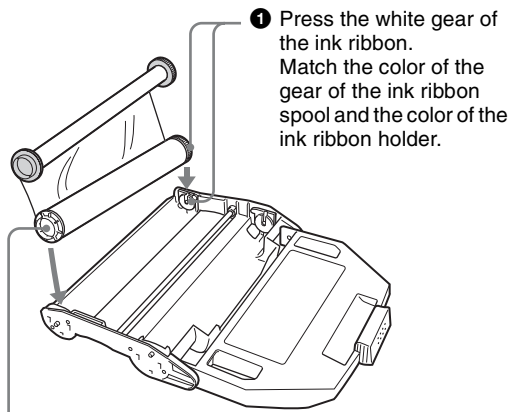

- ② Press the other side of the ink ribbon until you hear it click into place.

- ③ Place the ink ribbon with the gray gear in the same way as explained in step ②.

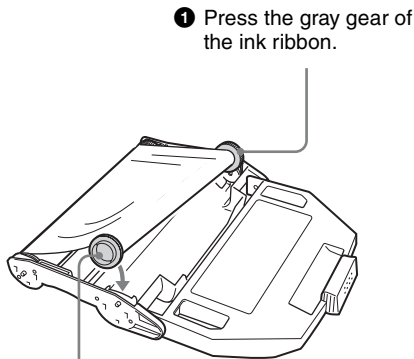

- ② Press the other side of the ink ribbon until you hear it click into place.

- ④ Eliminate any slack in the ribbon by turning the gears.

If the ribbon is left slack, it may be damaged when the ink ribbon cartridge is inserted into the printer.

Turn the gears in the direction of the arrows until any slack is eliminated and the magenta section of the ink ribbon appears.

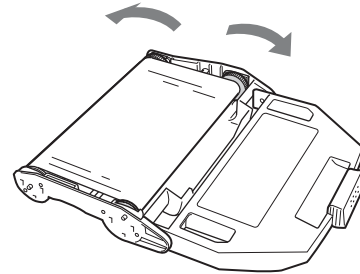

- 5 Insert the ink ribbon cartridge until it stops.

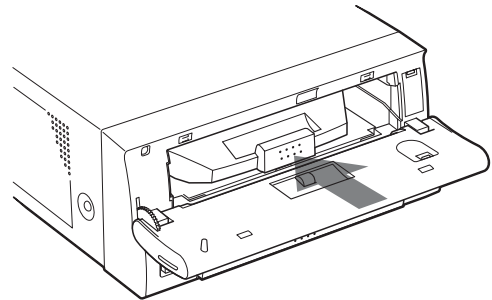

If the ink ribbon cartridge cannot be inserted

In such a case, close the front door, and turn the power off, then back on again. Insert the ink ribbon cartridge again.

6 Close the front door.

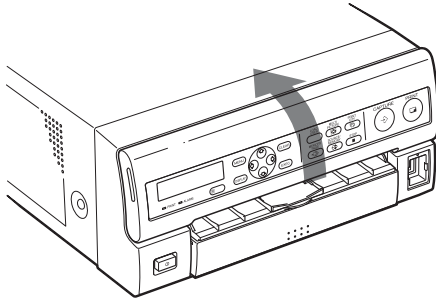

Notes

When handling the ink ribbon:

- Do not rewind the ink ribbon for reuse.
- When handling the ink ribbon, be careful not to touch the surface of the ink ribbon. Dust or finger prints are likely to cause unsatisfactory printing or malfunction of the head.

When storing ink ribbon:

- Avoid placing the ink ribbon in a location subject to:
 - high temperatures
 - high humidity
 - excessive dust
 - direct sunlight
- Store a partially used ink ribbon in its original packaging.

If your ink ribbon should tear

Repair the tear with transparent tape. There should be no problem with using the remaining portion of the ribbon.

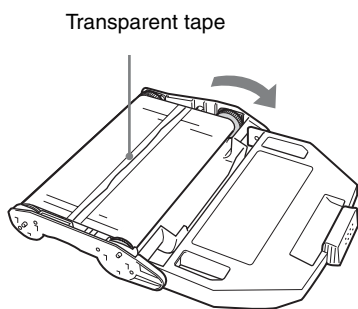

Turn the gray gear of the spool that takes up the ink ribbon in the direction of the arrow to remove any slack until the transparent tape cannot be seen.

Inserting the Paper Tray/Loading Paper

To load paper in the paper tray and insert the paper tray into the printer, follow the procedure below. Be careful not to touch the printing surface of the paper. When you use the printer for the first time, start the operation to insert the paper tray from step 2.

Notes

- Use only the paper recommended. Failing to do so is likely to result in malfunctions such as paper jams. (See “Ink Ribbon and Paper” on page 65.)
- When a blank sheet of paper is ejected and the message “RIBBON END” appears, the ink ribbon has been exhausted. Replace the paper together with the ink ribbon. Do not use the ejected blank paper.
- Be careful when removing and inserting the paper tray. If you are not careful, you may drop the printer.

- 1 Push the paper tray to remove it.

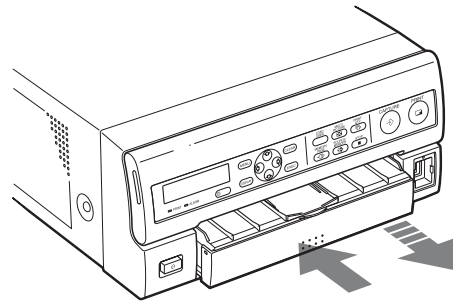

- 2 Place the paper in the paper tray so that the printing surface faces up with the protection sheet on top.

Notes

- Do not add only the paper. When the paper supply has been exhausted, replace both the ink ribbon and paper at the same time. If you add paper while printing, this may cause the paper jam.
- When handling the paper, do not touch the printing surface. Dust or finger prints are likely to cause unsatisfactory printing or malfunction of the head. Grasp the paper by the printing surface protection sheet.
- Load the paper so that it lays flat in the paper tray. If the paper is curled, it will overflow from the paper tray and paper may not be fed properly. **Be sure to ruffle the paper along with the**

protection sheets before placing the paper in the paper tray.

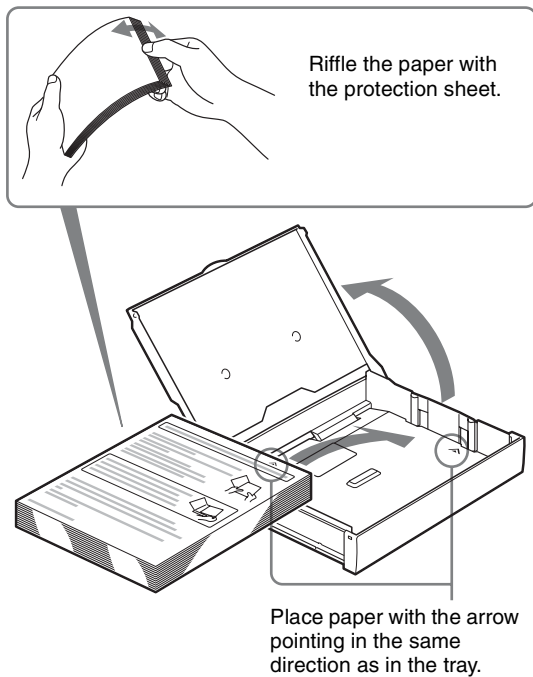

3 Remove the protection sheet placed on the top of the paper.

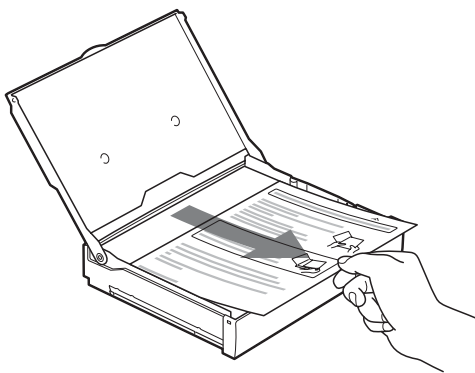

4 Slide the paper tray back into the printer until it clicks into place.

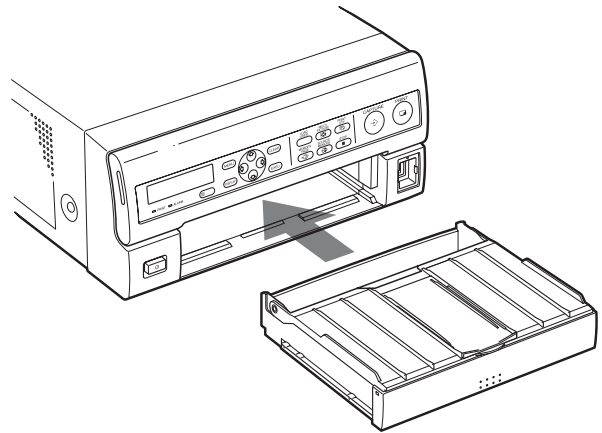

Note

If you cannot insert the paper tray completely, check whether any paper is left inside the printer. If you find a left sheet, slowly pull it straight out.

How to use the paper eject stopper

To keep ejected printouts on the paper tray, pull the paper eject stopper on the paper tray out until it clicks.

Note

Do not leave more than 10 sheets of ejected printouts. Doing so may cause a paper jam.

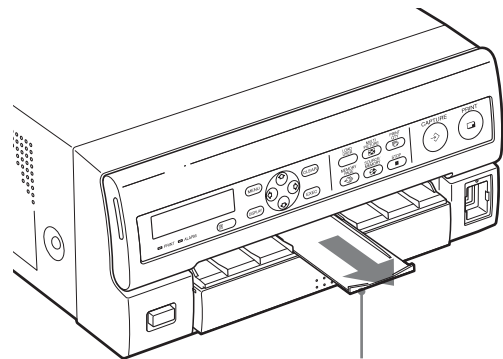

Pull the paper eject stopper on the paper tray out until it clicks.

When storing the paper

- Avoid storing the paper in a location subject to:
 - high temperatures
 - high humidity
 - excessive dust
 - direct sunlight
- Use the original package for storing unused paper.

Selecting the Input Signal

Before printing, select the appropriate input signal (the input connector to which the signal to be printed is being input) VIDEO, S VIDEO, or COMP.

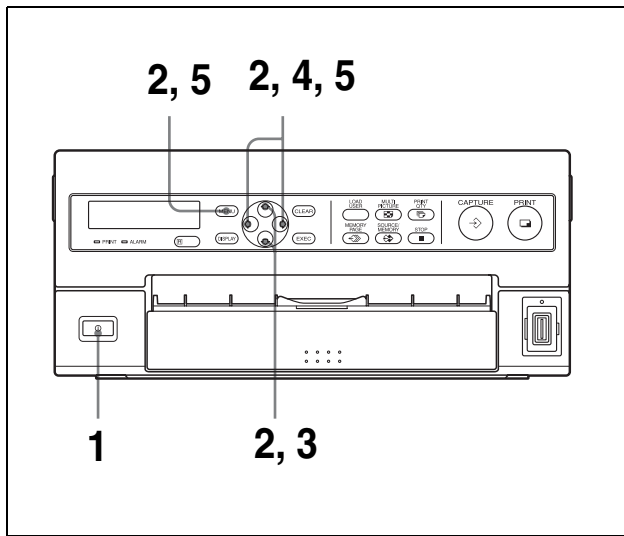

- 1 Turn on the video monitor and the printer.
- 2 Press the MENU button and display the INPUT SETUP menu by pressing the \uparrow , \downarrow , \leftarrow or \rightarrow button.

Highlight IN in green by pressing the \uparrow , \downarrow , \leftarrow or \rightarrow button, then the INPUT SETUP menu appears.

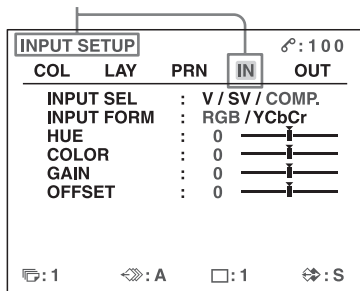

- 3 Select INPUT SEL by pressing the \uparrow or \downarrow button.

Highlight INPUT SEL in green by pressing the \uparrow or \downarrow button.

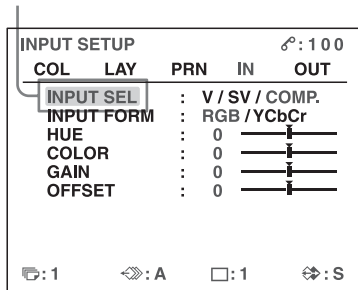

- 4 Select the desired input signal by pressing the \leftarrow or \rightarrow button.

Highlight the desired input signal in green by pressing the \leftarrow or \rightarrow button. The selected input signal turns green and is spelled out.

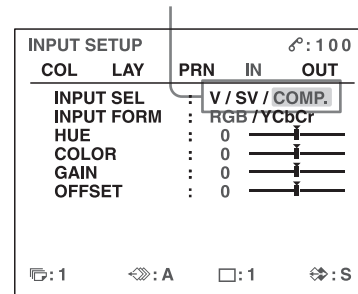

Source signal of the image to be printed	Video monitor and printer window display (the selected input signal is spelled out)
Signal from video equipment connected to the VIDEO IN connector	V → VIDEO
Signal from video equipment connected to the S VIDEO IN connector	SV → S-VIDEO
Signal from video equipment connected to the RGB/YCbCr/SYNC INPUT connectors	C → COMP.

When you select COMP.

When you use the RGB/YCbCr INPUT connectors to input the image data, select the appropriate type of the input signal.

- ① Select INPUT FORM by pressing the \downarrow button.

Highlight INPUT FORM in green by pressing the \downarrow button.

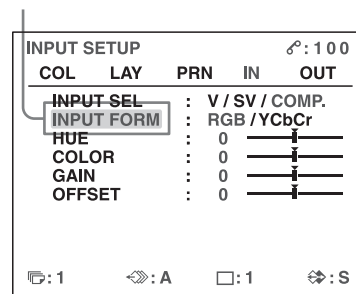

- ② Select the type of the input signal.

Highlight the desired input signal in green by pressing the \uparrow or \downarrow button.

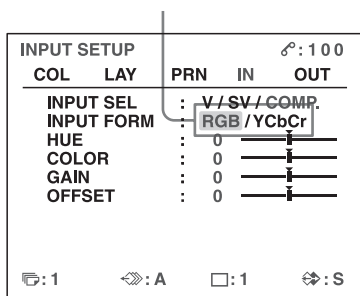

Signal input to the RGB/YCbCr/SYNC INPUT connectors	Select
RGB input signal	RGB
YCbCr input signal	YCbCr

The format of the component signal output from the RGB/YCbCr/SYNC OUTPUT connector depends on the component signal selected here.

- 5 Press the MENU button.
The normal screen appears.

Setting Date and Time

The printer adds a time stamp when the captured image data is stored on an external USB flash memory device. Also, you can make a printout with the date when the image was printed. To put the correct time stamp or to print the correct printing date on printouts, you have to set the correct date and time.

Note

The factory-installed battery is for monitoring. If date and time display lags, the battery may be drained. Please contact your Sony service facility or your Sony dealer.

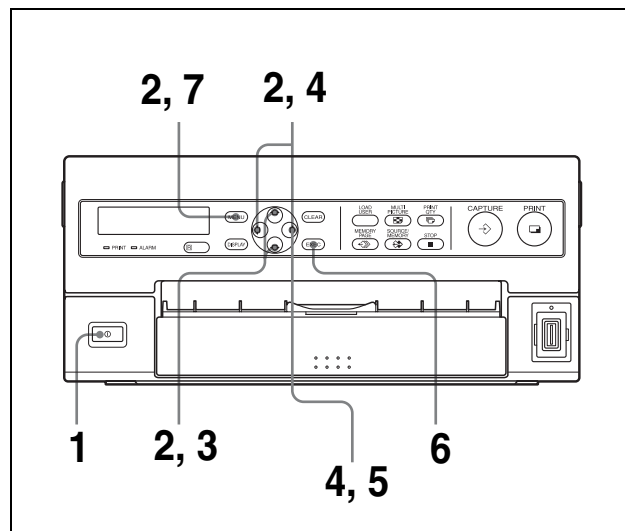

- 1 Turn on the video monitor and the printer.
- 2 Press the MENU button and display the LAYOUT SETUP menu by pressing the \uparrow , \downarrow , \leftarrow or \rightarrow button.

Switch LAY to green by pressing the \uparrow , \downarrow , \leftarrow or \rightarrow button, then the LAYOUT SETUP menu appears.

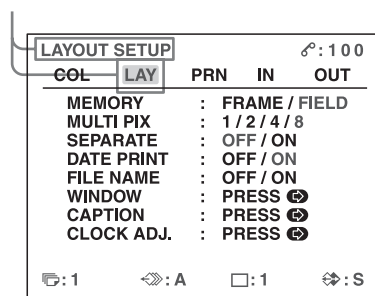

- 3 Select CLOCK ADJUST by pressing the \uparrow or \downarrow button.

Highlight CLOCK ADJUST in green by pressing the \uparrow or \downarrow button.

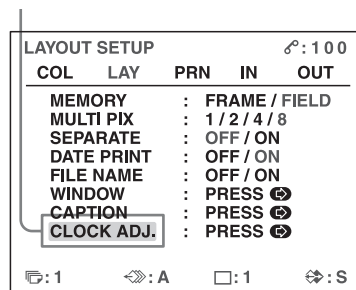

CLOCK ADJUST menu appears.

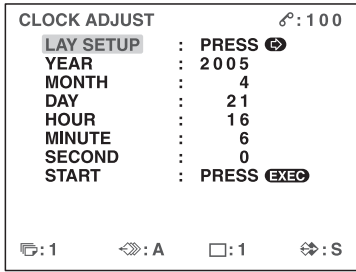

- 4 Set the year, month, day, hour, minute and second respectively.

To set year

- ① Press the \leftarrow button.
The YEAR column is highlighted in green.

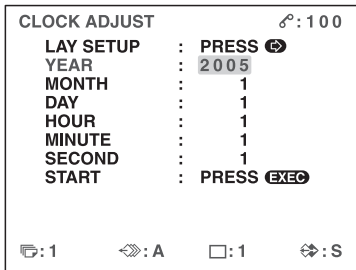

- ② Display the desired year by pressing the \leftarrow or \rightarrow button.

Press the \leftarrow or \rightarrow button until the desired year appears.

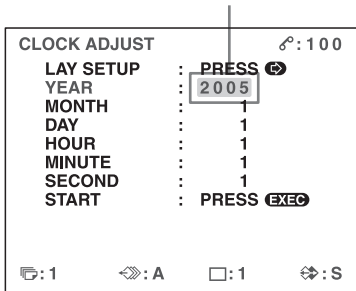

- ③ Highlight MONTH by pressing the \downarrow button.
④ Set MONTH, by repeating step ②.
⑤ Set from DAY to SECOND, by repeating steps ① and ②.
HOUR is a 24-hour display.

- 5 Highlight START by pressing the \downarrow button.

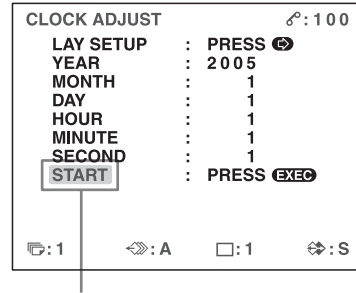

Switch START to green.

- 6 Press the EXEC button.
The internal clock starts.
7 Press the MENU button.
The normal screen appears.

Making Full-Size Image Printouts

This section explains how to make a full-size image printout. The operations described here constitute the basic procedure for making a printout.

Before making a full-size image printout

- All connections should have already been made. (See page 12.)
- Ensure that the appropriate ink ribbon/paper set is being used and that they are correctly loaded. (See pages 14, 17 and 65.)
- Select the input signal to be used to make a printout. (See page 19.)
- Set the printer to capture one full-size image into memory. (See page 32.)
- Select the appropriate memory page. (See page 30.)
- Confirm the printout color quality (using, for example, the LOAD COLOR number). (See page 53.)

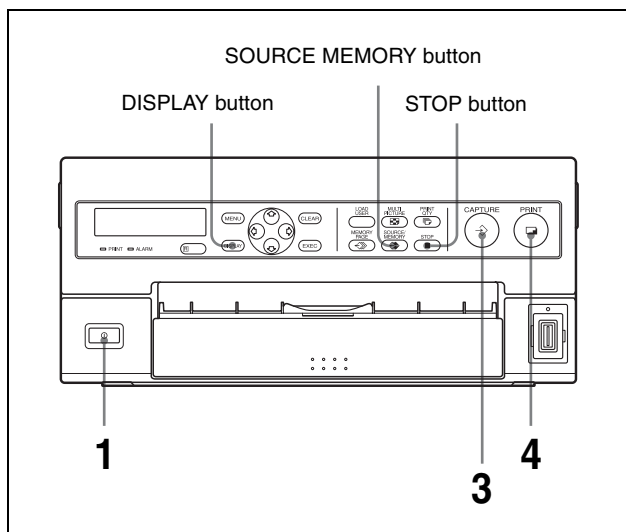

1 Turn on the video monitor and the printer.

2 Start the video source to display the source image on the video monitor. This operation is done using the controls of the video equipment acting as the source.



Shows that an image from the source equipment is currently displayed on the screen.

3 Press the CAPTURE button at the instant the image you want to print appears on the screen. The image is captured into memory. The memory image is displayed on the screen. Which image appears after this, the source image or the memory image, depends on the setting made with the FUNCTION SETUP facility of the printer. (See page 33.)



Shows that an image captured in memory is displayed on the monitor.

If the captured image is blurred

A quickly moving image may be blurred when captured. Should this occur, change the memory mode setting to FIELD, then print it again. Although the blur should be eliminated, the ultimate print quality will be slightly degraded. Select the FIELD mode on the LAYOUT SETUP menu. (See “Selecting the memory mode” on page 30.)

Note

Usually, it is recommended that you make printouts in FRAME mode.

You can confirm the memory mode setting on the bottom part of the video monitor screen.



When FRAME mode is selected:



When FIELD mode is selected:

To change the image captured in memory

- ① To display the source image when the memory image is displayed on the screen, press the SOURCE/MEMORY button.
- ② Press the CAPTURE button at the instant the image you want to print appears.
The previous image is replaced with the new one.

- 4 Press the PRINT button.
The printout pops out on the paper tray.

The printing time depends on the print speed settings.

On the video monitor, Q display blinks in the color which is being printed.

The color changes as follows during printing:
Start → yellow → magenta → cyan → finish

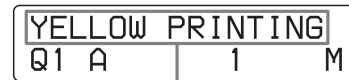
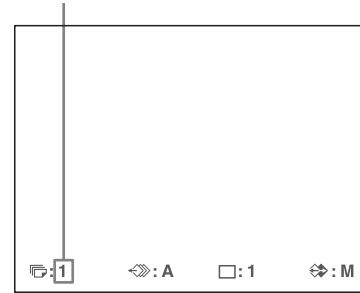

On the printer window display, the color indication changes as the color printing precedes:
Start → YELLOW → MAGENTA → CYAN → finish

Notes

- Do not turn off the power during printing.
If you do so, paper may not be ejected and may jam in the printer.
- Do not open the front door or not to remove the paper tray during printing. Doing so may cause the paper jamming because paper is not ejected correctly.
- Do not leave more than 10 sheets of printouts on the paper tray. Doing so may cause a paper jam. Even if fewer than 10 sheets of printouts have been accumulated on the paper tray, the printer may stop printing for various reasons and the message “REMOVE PRINTS” appears. In such a case, remove printouts accumulated on the paper tray. The printer will start to print automatically.
- You can not change the printer application mode or settings using the WINDOW SETUP menu during printing.

To stop printing

- When you make one printout, you can not stop printing midway. Wait until a printout pops out on the paper tray.
- When you make multiple copies, press the STOP button. (For detailed information on setting the print quantity, see “Making Multiple Copies of Identical Printouts” on page 26.) The printer stops printing when the page currently printing is completed. Also, any printing job queued are cancelled.

If the printer does not print

While an error message is displayed on the video monitor screen and printer window display. Proceed as described in “Error/Warning Messages” on page 67.

To make a printout at high speed

You can select the speed using the PRN SPEED item on the PRINTER SETUP menu.

When you want to	PRN SPEED
Make a printout at normal speed.	NORMAL
Make a printout at high speed.	HIGH

For detailed information on how to operate the menu, see “Basic Menu Operations” on page 49.

When you want to see an image that is hidden below a screen message

You can erase screen messages (such as Q1, A and so on) from the video monitor screen by pressing the DISPLAY button. The screen message disappears. To display a screen message, press the DISPLAY button again. (See “Erasing the Screen Display on the Video Monitor” on page 43.) You can also erase the information about ink ribbon and paper. (See “Displaying the Remaining Amount of the Ink Ribbon” on page 62.)

If a black line appears on the printout

Sometimes, a black line appears on the printout, although it does not appear on the video monitor. This black line can be eliminated from the printout. (See “When a Black Frame or Lines Show up on the Printouts” on page 56.)

If the color quality of the printouts is not satisfactory

You can obtain satisfactory color quality of the printouts by compensating for the input signal and/or adjusting the color quality of the printouts. (See “Compensating for the Input Signals” on page 52 and “Adjusting the Printout Color” on page 53.)

When you load a new ink ribbon and paper, the color balance may change due to differences caused by the new pair of ink ribbon and paper in the new printing pack. It is recommended that you adjust the color balance each time you load a new ink ribbon and paper. (“Adjusting the Color Balance” on page 57.)

When storing your printouts:

- Avoid storing the printout in a location subject to high temperatures, high humidity, excessive dust or direct sunlight.
- Do not stick tape on a printout. Also, avoid leaving a plastic eraser on a printout or placing a printout in contact with materials which contain plasticizer (under a desk mat, for example).

- Do not allow alcohol or other volatile organic solvents to come into contact with the printouts.

Making Printouts with the Desired User Set Number

You can register all the printer settings as a user settings. The printer allows you to register three sets of settings as User Set 1, 2 and 3. (See “Registering a User Set” on page 62.) By selecting a desired user set number, the printer functions according to the corresponding settings. You can change a part of the selected user settings and make printouts.

The following two methods are available to select the desired user set number:

- Using the LOAD USER button
- Using the menu

To select the desired user set number by using the LOAD USER button

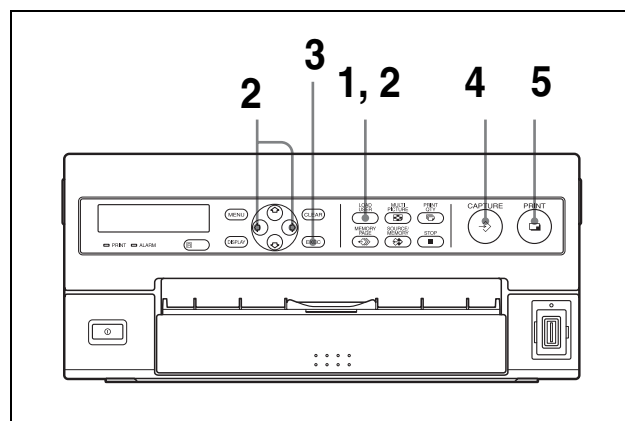

- 1 Press the LOAD USER button. The currently selected user set number appears.

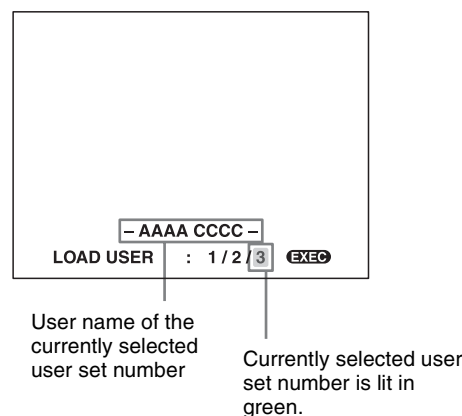

- 2 Select desired user set number by pressing the LOAD USER button, or \leftarrow or \rightarrow button. Each time you press the LOAD USER button, the user set number changes. The selected user set number will disappear within about three seconds.

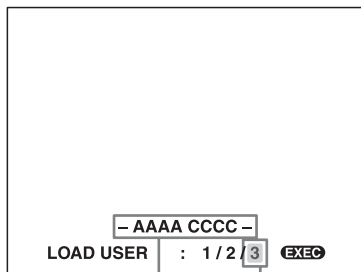

User name of the user set number selected

Highlight the desired user set number in green.

- 3 Press the EXEC button. The printer functions according to the settings selected in step 2.
- 4 Press the CAPTURE button at the instant the image you want to print appears on the screen. The image is captured into memory according to the user set selected in step 3.
- 5 Press the PRINT button. The printer makes printouts according to the user set selected in step 3.

To select the desired user set number by using the menu

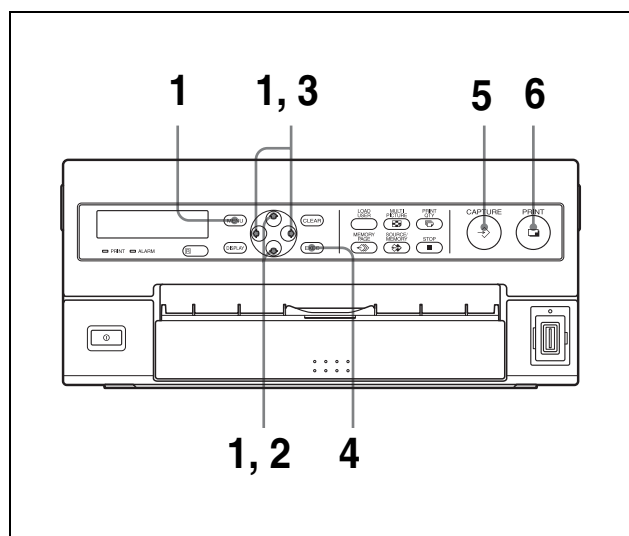

- 1 Press the MENU button, and display the PRINTER SETUP menu by pressing the \uparrow , \downarrow , \leftarrow or \rightarrow button.

Highlight PRN in green by pressing the \uparrow , \downarrow , \leftarrow or \rightarrow button, then the PRINTER SETUP menu appears.

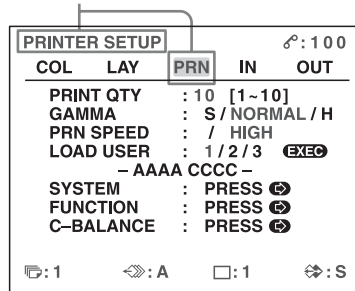

- 2 Select LOAD USER by pressing the \uparrow or \downarrow button.

Highlight LOAD USER in green by pressing the \uparrow or \downarrow button. The currently selected load user number is lit in green.

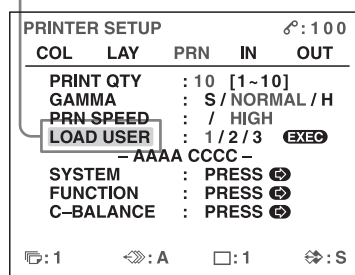

- 3 Select the desired user number by pressing the \leftarrow or \rightarrow button. The user name of the selected user set number appears.

Highlight the desired user number in green by pressing the \leftarrow or \rightarrow button. The user name of the selected user number appears below.

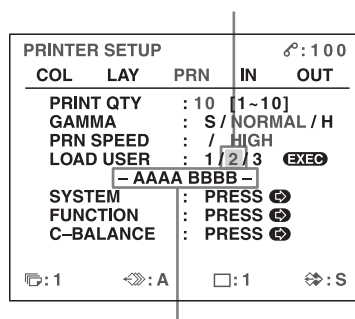

User name of the user set number selected

- 4 Press the EXEC button. The printer functions according to the settings selected in step 3.

- 5 Press the CAPTURE button at the instant the image you want to print appears on the screen.
The image is captured into memory according to the user set selected in step 3.
- 6 Press the PRINT button.
The printer makes printouts according to the user set selected in step 3.

Making Multiple Copies of Identical Printouts

You can make up to 10 copies of identical printouts.

Setting the printout quantity

The following two methods are available to set the number of printouts.

- Using the PRINT QTY button
However, you cannot use this button to decrease the number of printouts.
- Using the menu

You can change the designated number of copies before printing or any time during printing.

Note

When you change the designated number of copies during printing, only the number of copies of printouts which are being currently printed is changed. When printing is completed, the number of copies is reset to the one set before starting printing.

To set the printout quantity by using the PRINT QTY button

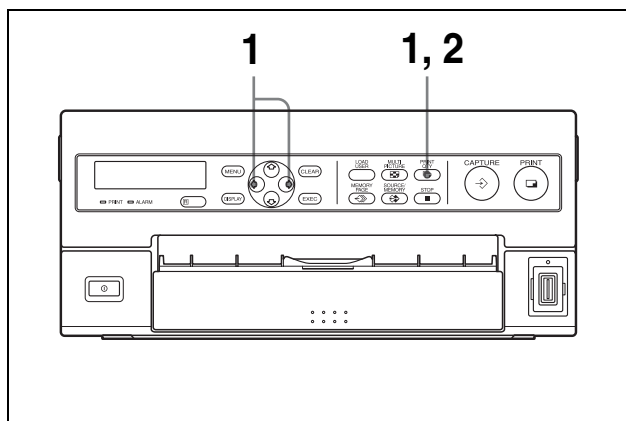

- 1 Press the PRINT QTY button.
The following screen appears.
If you do not perform any operation after you press the PRINT QTY button, the currently set number of

copies appears for a few seconds, after which it disappears.

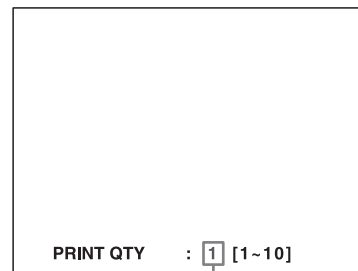

Currently selected number of copies

- 2 Press the PRINT QTY button until the desired number appears, while the screen shown in step 1 is displayed.
Repeatedly pressing the PRINT QTY button increases the number up to a maximum of 10. When the number reaches 10, if the button is pressed again, it goes back to 1. Or repeatedly pressing the ⇨ button also increases the number up to a maximum of 10. When the number reaches 10, if the ⇨ button is pressed again, it goes back to 1.

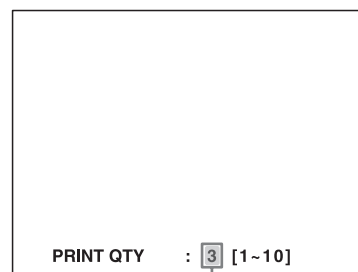

Press the PRINT QTY button or ⇨ button until the desired number appears.

To decrease the number of copies

While the screen which appears in step 1 is displayed, press the ⇨ button. Each time you press the ⇨ button, the number decreases. When the number reaches 1, if the ⇨ button is pressed again, it goes up to 10.

Setting the printout quantity using the menu

- 1 Display the PRINTER SETUP menu according to the operations of step 1 described in “To select the desired user set number by using the menu” on page 25.

2 Select PRINT QTY by pressing the \uparrow or \downarrow button.

Highlight PRINT QTY in green by pressing the \uparrow or \downarrow button.

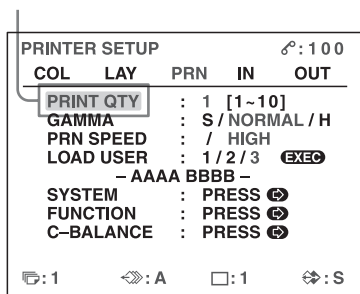

3 Select the desired number of copies by pressing the \leftarrow or \rightarrow button.

When you want to	Button
Increase the quantity.	\rightarrow
Decrease the quantity.	\leftarrow

Display the desired number of copies by pressing the \leftarrow or \rightarrow button.

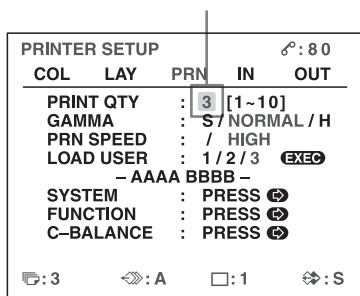

4 Press the MENU button. The normal screen appears.

Note

Do not leave more than 10 sheets of printouts on the paper tray. Doing so may cause a paper jam. Even if fewer than 10 sheets of printouts have been accumulated on the paper tray, the printer may stop printing for various reasons and the message "REMOVE PRINTS" appears. In such a case, remove printouts accumulated on the paper tray. The printer will start to print remaining copies automatically.

If the paper runs out during printing

The printer stops the printing operation. Load the paper into the paper tray and press the PRINT button.

However, the printout quantity is reset to the original quantity requested before printing was stopped. For example, if the printout quantity is set to 5, and the paper runs out when three copies are printed, the

printout quantity is reset to 5. If you want to print only the remaining copies, set the printout quantity to 2 after loading the paper. (See "Inserting the Paper Tray/Loading Paper" on page 17.)

Capturing Another Image While Printing

While the printer is printing, you can queue printing jobs by capturing another image into another memory page to be printed once the printer becomes free. The number of usable memory pages depend on the type of printouts and settings. (See “Memory page” on page 30.)

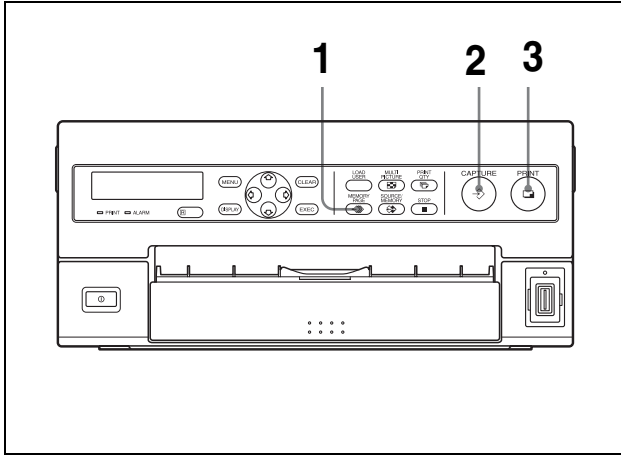

- 1 Select the desired memory page by pressing the MEMORY PAGE button. Pressing the MEMORY PAGE button switches the memory page.

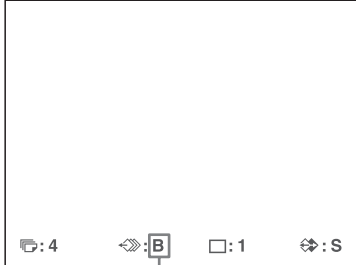

The available memory pages do not blink. They are lit.

- 2 Press the CAPTURE button at the instant the image you want to print appears on the screen.

- 3 Press the PRINT button. The image captured in step 2 is queued. The image is printed as soon as all previous printing jobs have been completed.

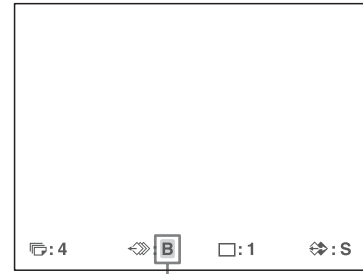

Memory page whose image has been queued for printing (blinks on the video monitor)
The memory page display stop blinking and lights up on the video monitor once printing has been completed.

Note

Another image cannot be stored in a memory page in which an image has already been queued for printing (memory page indication blinks). In such a case, the “PLEASE WAIT PRINTING MEMORY” message also appears.

- 4 To queue another memory page, repeat steps 1, 2 and 3.

Making Variations of Printouts

You can capture various kinds of images in memory and make variations of printouts using the images captured in memory.

Printout of a full-size image



Printout of two reduced images

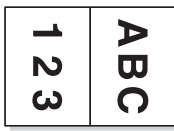

Printout of four reduced images

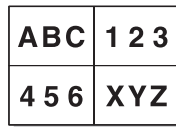

Printout of eight reduced images

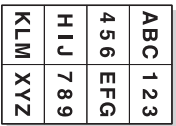

You can also make printouts of multiple reduced images with white borders. (See “Making a printout with white borders” on page 35.)

Selecting the Memory Mode

Frame mode/field mode

To make printouts, it is first necessary to capture the image in memory.

When capturing an image, there are two ways to use the memory, one is called frame mode and the other is called field mode.

Frame mode: An image is captured in a memory area. Printouts with high resolution can be obtained.

Video monitor

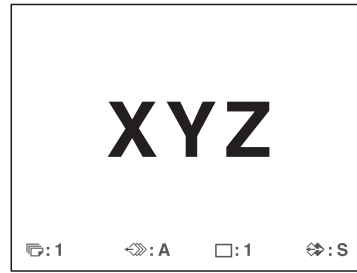

The image displayed on the video monitor is captured in memory page A.

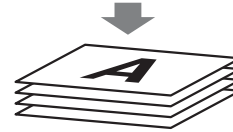

Printout



A still subject can be printed with high resolution.

Field mode: A memory area is divided into two, and images can be captured in each. In this way a quickly moving subject can be printed with less blurring.

Video monitor

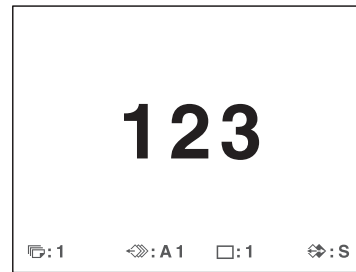

The image displayed on the video monitor is captured in memory page A1.

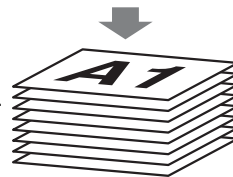

Printout



A quickly moving subject can be printed with less blurring.

Selecting the memory mode

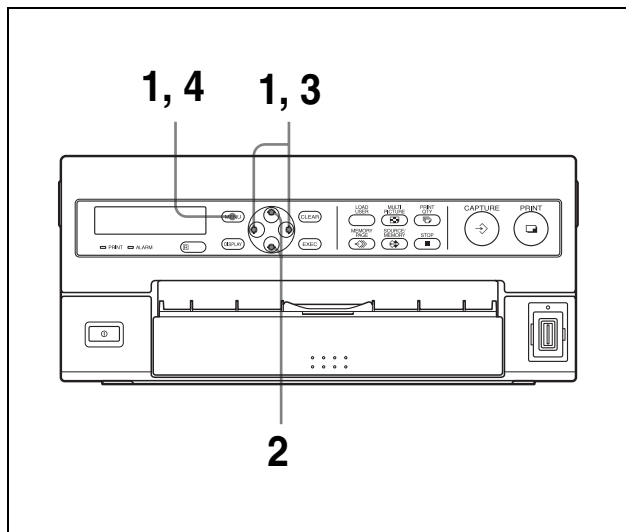

- 1 Press the MENU button and display the LAYOUT SETUP menu by pressing the \leftarrow or \rightarrow button.

Highlight LAY in green by pressing the \leftarrow or \rightarrow button, then the LAYOUT SETUP menu appears.

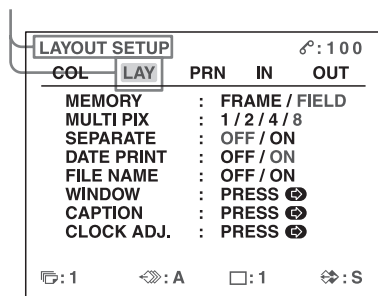

- 2 Select MEMORY by pressing the \uparrow or \downarrow button.

Highlight MEMORY in green by pressing the \uparrow or \downarrow button.

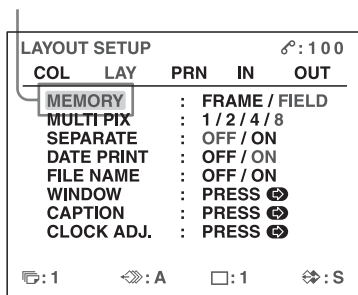

- 3 Select the desired memory mode by pressing the \leftarrow or \rightarrow button.

Highlight the desired memory mode in green by pressing the \leftarrow or \rightarrow button.

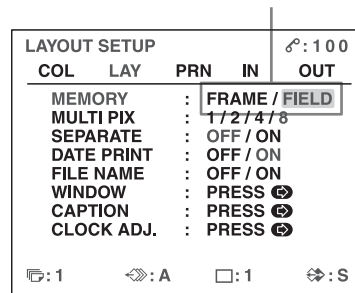

Mode	Contents
FRAME	We recommend that, whenever possible, you print in this mode.
FIELD	Select this mode to reduce blurring when you print a quickly moving image.

- 4 Press the MENU button. The normal screen appears.

Selecting a Memory Page

Memory page

A memory area in which an image is captured is called a memory page in this manual.

The number of usable memory pages depends on the type of the reduced images selected and on the memory mode.

Usable memory page	Type of reduced images to be captured in memory
FRAME	FIELD
A, B, C, D, E, F, G, H	A1, A2, B1, B2, C1, C2, D1, D2, E1, E2, F1, F2, G1, G2, H1, H2
A, B, C, D	A1, A2, B1, B2, C1, C2, D1, D2
A, B	A1, A2, B1, B2
A	A1, A2

Selecting a memory page

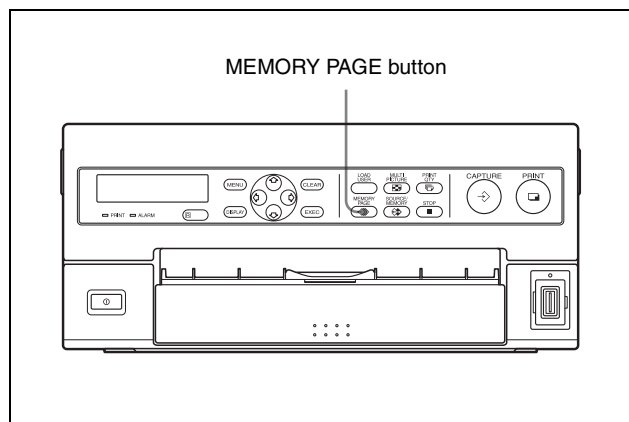

Press the MEMORY PAGE button repeatedly until the desired memory page appears.



Currently selected memory page

Making a Printout of Multiple Different Reduced Images

You can capture multiple images in a memory page and make a printout with those reduced images. This section explains how to make a printout with multiple reduced images.

A printout having multiple reduced images is made using the procedure below.

- Determining the number of reduced images (See below.)
- Selecting the memory page (See page 31.)

Selecting the number of reduced images to be captured in memory

The following two methods are available to select the number of reduced images:

- Using the MULTI PICTURE button
- Using the menu

To select the desired type of reduced images to be captured in memory using the MULTI PICTURE button

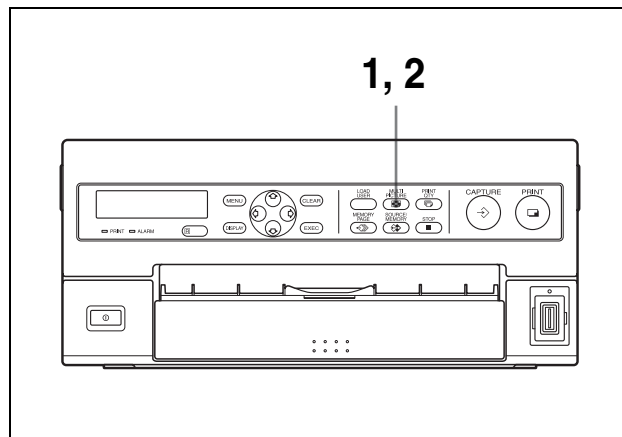

- 1 Press the MULTI PICTURE button.
The following screen appears.

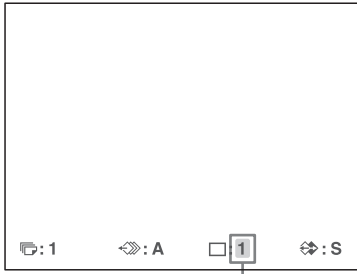

The currently selected type of reduced images to be captured in memory is lit in green.

If you do not perform any operation after you press the MULTI PICTURE button, the current setting appears for a few seconds, after which it disappears.

- 2 Select the type of reduced images to be captured in memory by pressing the MULTI PICTURE button, while the screen which appears in step 1 is displayed.
Press the MULTI PICTURE button repeatedly until the color of the type of reduced images to be captured in memory turns green on the video monitor, or until the type of reduced images to be captured in the memory is displayed on the printer window display.
Each time you press the MULTI PICTURE button, the type of reduced-image printout changes in the following sequence: 1, 2, 4, 8, 1....

Type	Number of reduced images
1	1 (Full-size image)
2	2 (Two reduced images)
4	4 (Four reduced images)
8	8 (Eight reduced images)

The screen is reset to the regular screen after a few seconds.

To select the type of reduced images to be captured in the memory using the menu

- 1 Display the LAYOUT SETUP menu according to the operations of step 1 described in “Selecting the memory mode” on page 30.

- 2 Select MULTI PIX by pressing the ⬆ or ⬇ button.

Highlight MULTI PIX in green by pressing the ⬆ or ⬇ button.

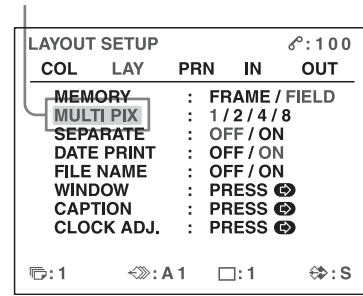

- 3 Select the type of reduced images to be captured in memory by pressing the ⬅ or ➡ button.

Highlight the type of reduced images to be captured in memory in green by pressing the ⬅ or ➡ button.

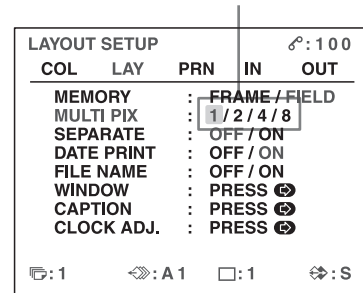

- 4 Press the MENU button.
The normal screen appears.

Deciding which image is displayed on the video monitor screen after capturing an image

You can switch image displayed on the video monitor screen after capturing an image, a memory image or a source image.

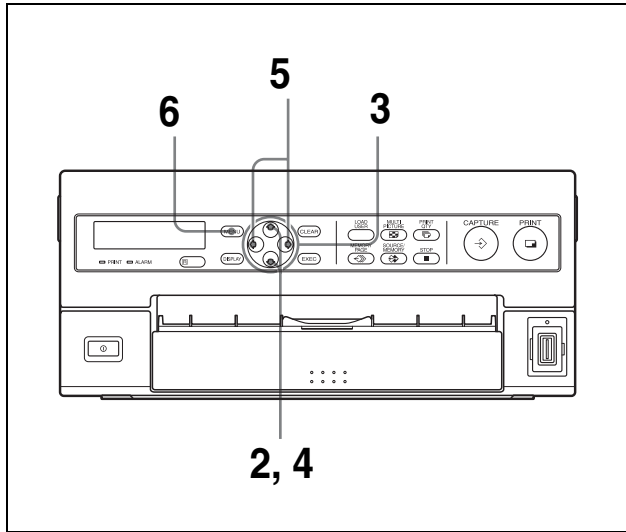

- 1 Display the PRINTER SETUP menu according to the operations of step 1 described in “To select the desired user set number by using the LOAD USER button” on page 24.
- 2 Select FUNCTION by pressing the \uparrow or \downarrow button.

Highlight FUNCTION in green by pressing the \uparrow or \downarrow button.

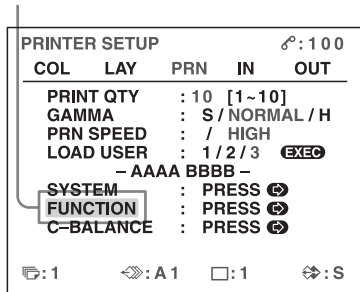

- 3 Press the \rightarrow button.
The FUNCTION SETUP menu appears.

- 4 Select AUTO LIVE by pressing the \uparrow or \downarrow button.

Highlight AUTO LIVE in green by pressing the \uparrow or \downarrow button.

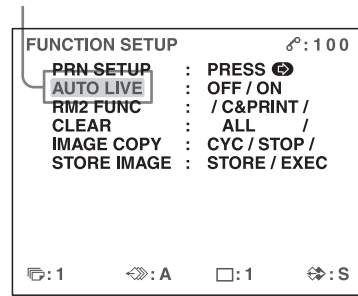

- 5 Select which image appears on the video monitor after the image is captured, by pressing the \leftarrow or \rightarrow button.

When	Setting
The image captured in memory appears just after the printer captures the image, and the memory image remains on the video monitor screen.	OFF
The image captured in memory appears just after the printer captures the image, then after a few seconds, the source memory appears, whenever you press the CAPTURE button.	ON

- 6 Press the MENU button.
The regular screen appears.

To return to the PRINTER SETUP menu

In step 6, position the cursor at PRN SETUP and press the \rightarrow button.

The PRINTER SETUP menu appears again.

Making a printout with multiple reduced images

This subsection explains how to make printouts of multiple reduced images taking, as an example, the making of a printout of four reduced images.

Before making the printout of four reduced images

- Confirm the printout color quality (using, for example, the LOAD COLOR number). (See page 53.)
- Select the type of four-reduced image to be captured in memory. (See page 31.)
- Select the appropriate memory page. (See page 31.)
- Select which image will appear after the image has been captured into memory, the memory image or the source image. (See page 33.)
- Select whether the white borders are to be added. (See page 35.)

You can select whether white borders are added before or after capturing the four reduced images in the memory.

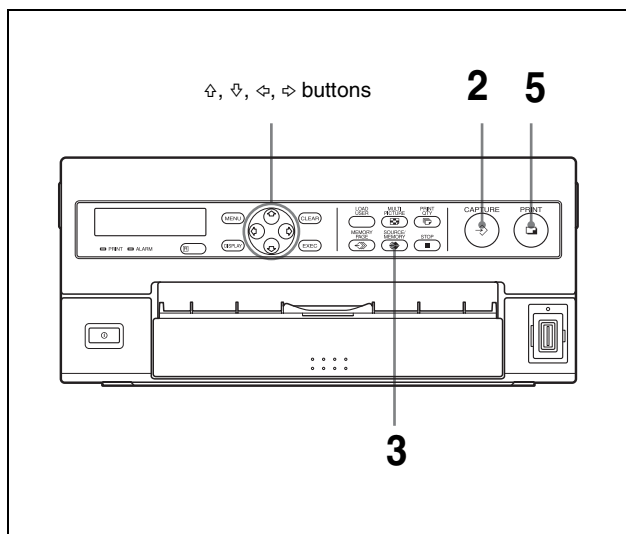

- 1** Start the video source.
This operation is done using the controls of the video equipment acting as the source.

In the mode where white borders are to be attached around the images, the white borders appears on the screen.

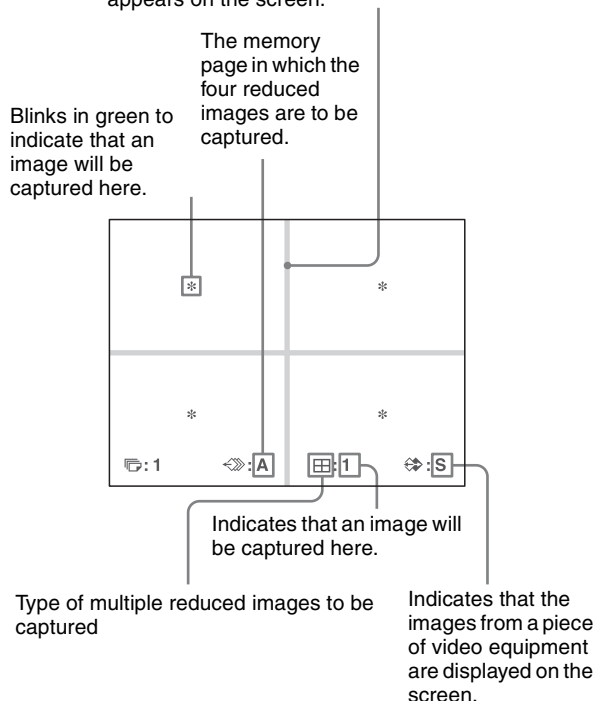

- 2** Press the CAPTURE button at the instant the image you want to print appears on the screen. The image is captured in the location indicated by the green blinking star on the video monitor screen or the position number displayed on the printer window display in step 1. The green blinking star (referred to as the cursor) on the video monitor moves to the next position and the number on the printer window display advances by 1.

The blinking cursor moves to the next position.

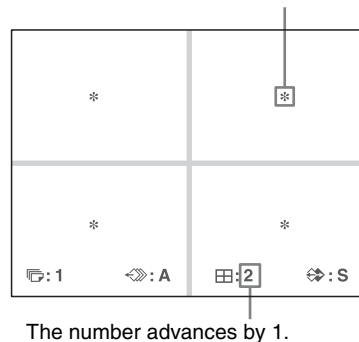

At this time, the image captured in memory is displayed on the video monitor screen. However, the image to be displayed after a few seconds depends on the setting of AUTO LIVE in the FUNCTION SETUP menu. (See page 33.)

When the image captured in memory is kept being displayed, go to step 3.

When the source image is displayed, go to step 4.

3 Press the SOURCE/MEMORY button.
The source image appears on the video monitor screen.

4 Repeat steps 2 and 3 until you have captured four images when the memory image remains on the video monitor screen.
Repeat step 2 until you have captured four images when the source image appears on the video monitor screen.

To replace a captured image

Example: When you want to change the image captured in the third position.

- 1 Select the third position where the image which you want to replace is located by pressing the \uparrow , \downarrow , \leftarrow or \rightarrow button.
Pressing the \uparrow , \downarrow , \leftarrow or \rightarrow button moves the cursor one position by one position vertically or horizontally.

Press the \uparrow , \downarrow , \leftarrow or \rightarrow button until the third cursor blinks green.

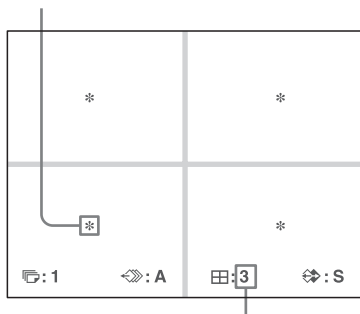

Press the \leftarrow , \downarrow , \rightarrow or \rightarrow button until a 3 appears.

- 2 Display the source image on the video monitor.
For detailed information on how to display the source image, see step 3.
- 3 Press the CAPTURE button at the instant the image you want to print appears.
The previously captured image is replaced with the newly captured image.

To keep a previously captured image

Skip images that you want to keep by pressing the \uparrow , \downarrow , \leftarrow or \rightarrow button.

5 Press the PRINT button.
The four reduced images are printed on one sheet of paper.

Whether white borders are attached depends on the setting of SEPARATE in the LAYOUT SETUP menu. (See page 35.)

If the printout is blurred

When you make a printout of a full image, or two or four reduced images captured in memory in FRAME mode, the images on a printout may be blurred. Should this occur, change the memory mode setting to FIELD on LAYOUT SETUP menu (“Selecting the memory mode” on page 30), then print it again. Although the blur should be eliminated, the ultimate print quality will be slightly degraded.

Note

Usually, it is recommended that you make printouts in FRAME mode. Check the setting on the LAYOUT SETUP menu.

Making a printout with white borders

The unit allows you to decide whether or not the images are printed with white borders.

Note

This setting is also effective for the images which have been captured.

- 1 Display the LAYOUT SETUP menu according to the operations of step 1 described in “Selecting the memory mode” on page 30.
- 2 Select SEPARATE by pressing the \uparrow or \downarrow button.

Highlight SEPARATE in green by pressing the \uparrow or \downarrow button.

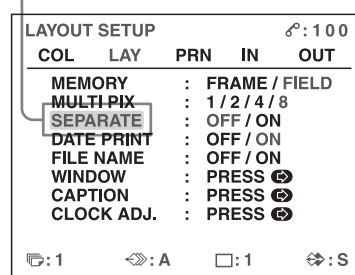

- 3 Select whether the images are printed with or without white borders by pressing the \leftarrow or \rightarrow button.

Switch the desired setting to green by pressing the \leftarrow or \rightarrow button.

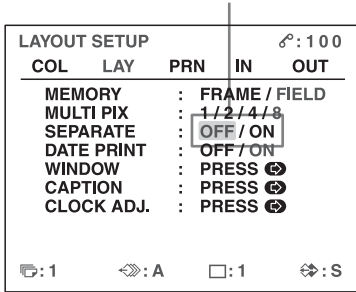

When you want to	Setting
Print the images without white borders.	OFF
Print the images with white borders.	ON ^{a)}

- a) F is attached to the type of printout at the printer operation mode display section in the printer window display.
Example: 4F

- 4 Press the MENU button.
The regular screen appears.

Making Printouts With Date or a Caption

Making Printouts With a Caption

A caption, such as comments, can be added to a printout below the image.

You can input up to 80 characters on one lines.

About the CAPTION menu

A caption is entered from the CAPTION menu.

A brief explanation of each item of the CAPTION menu is given below.

Symbols and words can be used to enter a caption.

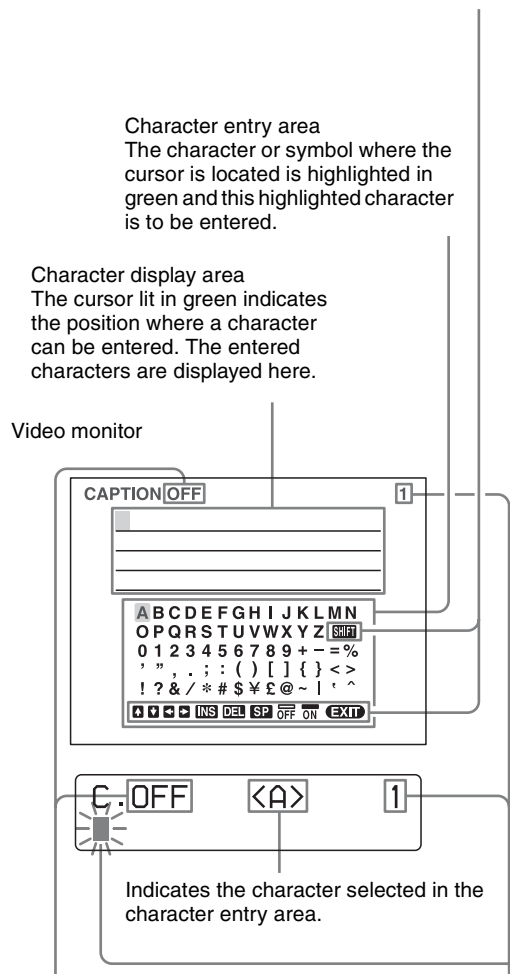

Character entry area
The character or symbol where the cursor is located is highlighted in green and this highlighted character is to be entered.

Character display area
The cursor lit in green indicates the position where a character can be entered. The entered characters are displayed here.

Video monitor

Indicates the character selected in the character entry area.

ON: displayed when printing with a caption.
OFF: displayed when printing without a caption.

Indicates the position where the character is to be input in the character display area.

Symbols and words can be used to enter a caption

Display in the CAPTION menu	Function
INS	Inserts one character without erasing the highlighted character.
DEL	Deletes a highlighted character and characters shift back by one.
SP	Puts one space at the position of the highlighted character by erasing that character. One space is left.
OFF	Selects printing without a caption.
ON	Selects printing with a caption.
EXIT	Returns from the CAPTION menu to the LAYOUT SETUP menu.
SHIFT	Selects either capital letters or small letters.

Entering a Caption

Enter a caption as follows.
The setting remains effective until you enter a new setting – even if you turn the power off.

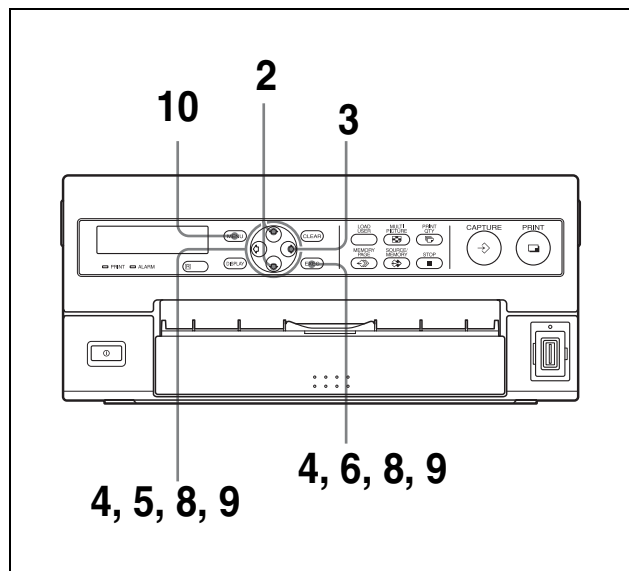

- 1 Display the LAYOUT SETUP menu according to the operations of step 1 described in “Selecting the memory mode” on page 30.

- 2 Select CAPTION by pressing the \uparrow or \downarrow button.

Highlight CAPTION in green by pressing the \uparrow or \downarrow button.

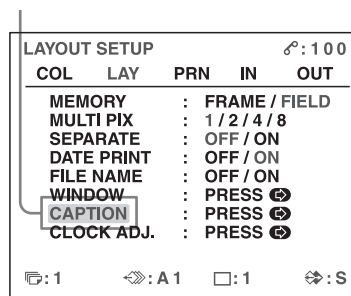

- 3 Press the \rightarrow button.
The CAPTION menu appears.
- 4 Position the cursor (the line lit in green) at the point where you want to enter the character in the character display area.

To move the cursor

- 1 Select the arrow corresponding to the direction in which you want to move the green cursor in the character display area, by pressing the \uparrow , \downarrow , \leftarrow or \rightarrow button.
- 2 Press the EXEC button.
Each time you press the EXEC button, the cursor moves one position in the designated direction.

Example: Move the cursor to the left by two.

- 1 Highlight the ⇐ button in green. The cursor is currently positioned here (lit in green).

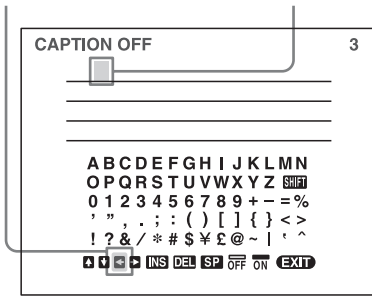

- 2 Press the EXEC button twice. The blinking cursor moves to this position.

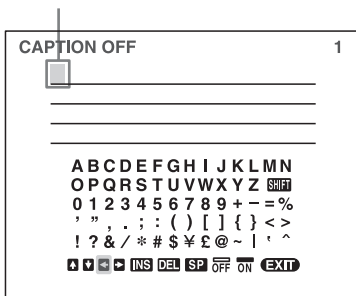

- 5 Select the character you want to enter by pressing the ⇕, ⇓, ⇐ or ⇨ button.

Example: Enter S.

Highlight S in green by pressing the ⇕, ⇓, ⇐ or ⇨ button. S blinks in green.

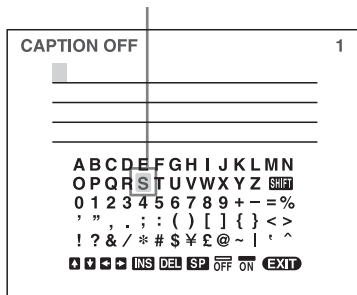

When you enter characters on the printer window display:

It is recommended that you display the characters to be entered on the printer window display by pressing either ⇐ or ⇨ button.

When the cursor is positioned at the right end:

The cursor moves to the left end on the next line when you press the ⇨ button.

For example, when the cursor is positioned at N, pressing the ⇨ button results in the cursor moving to O at the left end on the next line.

When the cursor is positioned at EXIT:

Only the ⇐ and ⇨ buttons are effective. If you press the ⇨ button, the cursor moves to the top on the first line, that is A.

To select either capital letters or small letters

You can change the characters in the character entry area from capital letters to small letters or vice versa.

- 1 Highlight SHIFT in green by pressing the ⇕, ⇓, ⇐ or ⇨ button on the video monitor. Or display SHIFT or shift on the printer window display. When characters are displayed in capital letters in the character entry area, shift is displayed in the printer window display. When displayed in small letters, SHIFT is displayed.
- 2 Press the EXEC button. Capital letters are changed to small letters, or small letters are changed to capital letters in the character entry area.

Note

Characters already entered (displayed in the character display area) are not changed even if letters are changed in the character entry area.

- 6 Press the EXEC button. The character selected in step 5 appears at the point where the green cursor is positioned in the character display area, after which the cursor moves to the next position.

The cursor moves to this position.

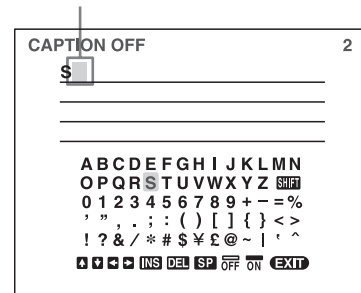

When you enter the wrong character in the above example

- 1 Select ✖ by pressing the ⇕, ⇓, ⇐ or ⇨ button, then press the EXEC button.

The cursor moves back by one and the character entered in step 5 is highlighted in green.

- ② Select DEL by pressing the ⬆, ⬇, ⬅ or ➡ button.

Lit in green Highlight DEL in green by pressing the ⬆, ⬇, ⬅ or ➡ button. DEL blinks in green.

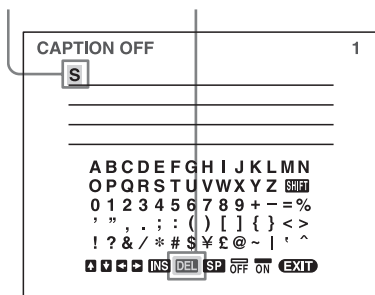

- ③ Press the EXEC button.
The character selected in ① is deleted. When the character to be deleted is located among previously entered characters, the characters after the deleted one shift back by one.

7 Repeat steps 4, 5 and 6 to enter the remaining characters of the caption.

To enter a space

- ① Position the green cursor at the point where you want to enter a space.
- ② Select SP by pressing the ⬆, ⬇, ⬅ or ➡ button.
- ③ Press the EXEC button.
A single space is entered and the green cursor moves to the next position. If there is a character at the position where the space is entered, that character is deleted and a single space is left.

To replace a previously entered character without changing the number of characters

You can replace a previously entered character with a new one.

- ① Position the green cursor at the character to be replaced by performing the operations explained in step 4.
- ② Overwrite the invalid character with the correct character by performing the operations explained in steps 5 and 6. The previously entered character is replaced with the new one.

To add characters midway

- ① Position the cursor at the position where a character is to be added by performing the operations explained in step 4.
- ② Select INS by pressing the ⬆, ⬇, ⬅ or ➡ button. Then press the EXEC button. A single space is inserted between characters and the cursor is positioned at the space.
- ③ Enter the character to be added. When it is necessary to change the CAPTION ON/OFF setting, go to step 8. If not, go to step 9.

Example: Add a character between A and B.

- ① Move the cursor to B. (B is highlighted in green.)

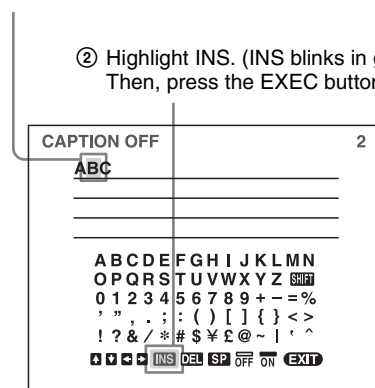

- ② Highlight INS. (INS blinks in green). Then, press the EXEC button.

A single space is inserted between A and B and the green cursor is positioned at the space.

Cursor (lit in green)

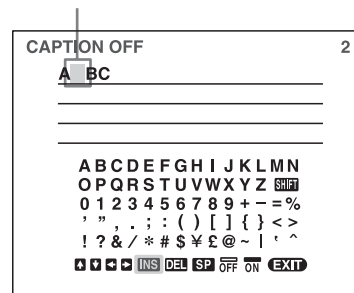

- 8** Set the CAPTION ON/OFF function to ON.

- 1 Select ON by pressing the \uparrow , \downarrow , \leftarrow or \rightarrow button.

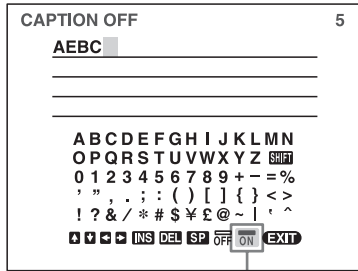

Highlight ON by pressing the \uparrow , \downarrow , \leftarrow or \rightarrow button. ON blinks in green.

Select OFF to make printouts without a caption.

- 2 Press the EXEC button.
The display changes from OFF to ON.

The display changes from OFF to ON.



- 9 After entering the caption, highlight EXIT by pressing the \uparrow , \downarrow , \leftarrow or \rightarrow button, then press the EXEC button.
The entered characters are stored in memory.
The LAYOUT SETUP menu appears.

- 10 Press the MENU button.

Note

Characters entered in steps 4 to 7 are stored after completing the operation of step 7. These characters remain even after you turn off the printer.

Making Printouts with a Date

- 1 Display the LAYOUT SETUP menu according to the operation in step 1 described in “Selecting the memory mode” on page 30.

- 2 Select DATE PRINT by pressing the \uparrow or \downarrow button.

Highlight DATE PRINT in green by pressing the \uparrow or \downarrow button.

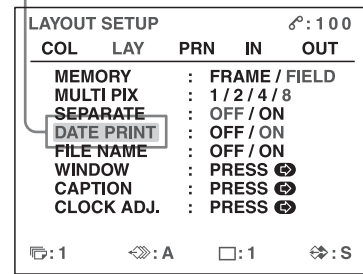

- 3 Decide whether or not printouts will be printed with a date by pressing \leftarrow or \rightarrow button.

Highlight desired setting in green by pressing the \leftarrow or \rightarrow button.

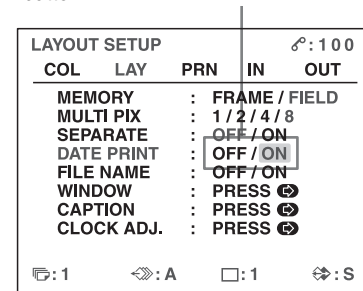

When you want to	Setting
To make printouts without a date.	OFF
To make printouts with date	ON ^{a)}

- a) To make printouts with the correct date, see the following “To make printouts with the correct date”.

- 4 Press the MENU button.
The normal screen appears.

Note

The date is printed on the bottom right of the printout. If the date and any printed comments overlap, the comment is printed with priority over the date.

To make printouts with the correct date

The day and time setting is necessary.
For detailed information, see “Setting Date and Time” on page 20.

Deleting Images Stored in Memory

You can delete images captured to memory pages, from either all of the memory pages or a single memory page, by using the CLEAR button.

Whether the images of all memory pages or only a single memory page are deleted depends on the setting of CLEAR in the FUNCTION SETUP menu.

Setting the Function of the CLEAR Button

- 1 Display the FUNCTION SETUP menu according to the operations of steps 1 to 3 described in “Deciding which image is displayed on the video monitor screen after capturing an image” on page 33.
- 2 Select CLEAR by pressing the \uparrow or \downarrow button.

Highlight CLEAR in green by pressing the \uparrow or \downarrow button.

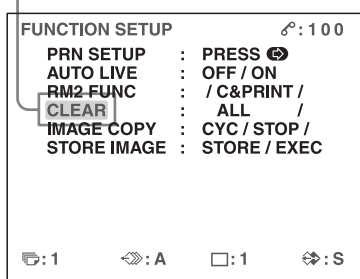

- 3 Select the function of the CLEAR button by pressing the \leftarrow or \rightarrow button.

Highlight the desired function in green by pressing the \leftarrow or \rightarrow button.

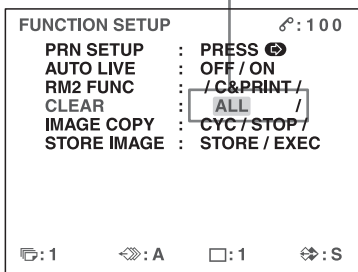

When you want to	Settings
Delete images of all memory pages.	ALL
Delete images of a single memory page.	PAGE
Delete the reduced image.	PART
Deactivate the CLEAR button.	OFF

- 4 Select PRN SETUP by pressing the \uparrow or \downarrow button. Then, press the \rightarrow button. The PRINTER SETUP menu appears. Once you set the function of the CLEAR button, the CLEAR button functions according to the setting until the function setting is changed.

To return to the regular screen

Press the MENU button.

Deleting Images Stored in Memory

Note

You cannot restore images once they have been deleted.

Deleting images in all memory pages simultaneously

Before deleting images in all memory pages

Set CLEAR to ALL in the FUNCTION SETUP menu.

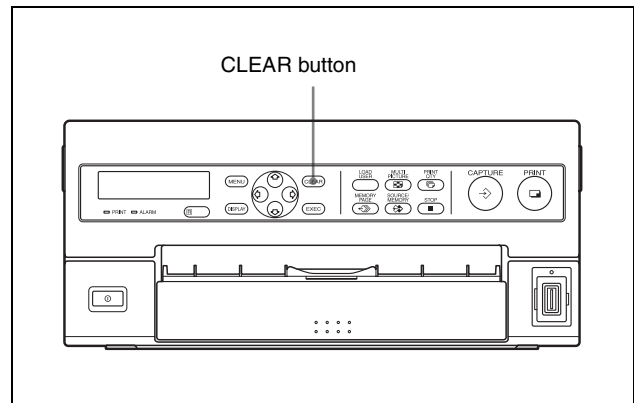

Press the CLEAR button.

All images captured in the printer are cleared.

Notes

- Even if you press the CLEAR button when the source image is displayed on the video monitor, the memory image appears without deleting images in the memory pages. In this case, press the CLEAR button again. All images stored in the printer are cleared.
- An image which is being printed and the images queued in the memories cannot be cleared.

Deleting images in a certain memory page

Before deleting images

Set CLEAR to PAGE in the FUNCTION SETUP menu.

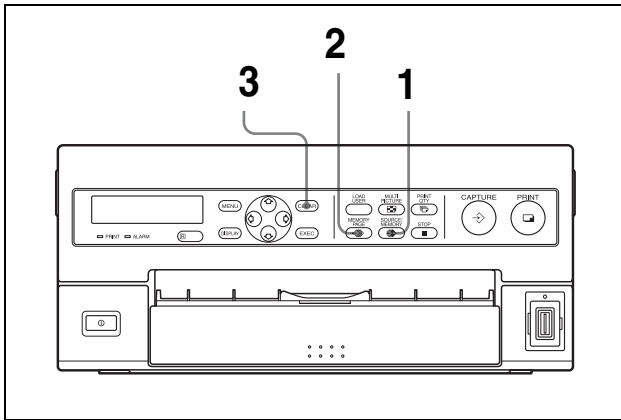

- 1** Press the SOURCE/MEMORY button when the source image is displayed on the video monitor screen.
The image captured in memory is displayed on the screen.
- 2** Select the memory page from which images are to be deleted by pressing the MEMORY PAGE button.
- 3** Press the CLEAR button.
The image in the memory page selected in step 2 is deleted.

Deleting a certain reduced image

Before deleting images

Set CLEAR to PART in the FUNCTION SETUP menu.

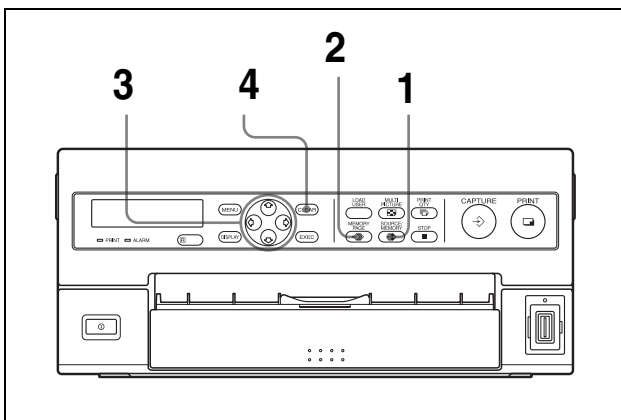

- 1** Press the SOURCE/MEMORY button when the source image is displayed on the video monitor screen.
The image captured in memory is displayed on the screen.

- 2** Select the memory page from which the reduced image is to be deleted by pressing the MEMORY PAGE button.
- 3** Select the reduced image that you want to delete by pressing the \uparrow , \downarrow , \leftarrow or \rightarrow button.

Make the cursor at the reduced image to be deleted bling in green.

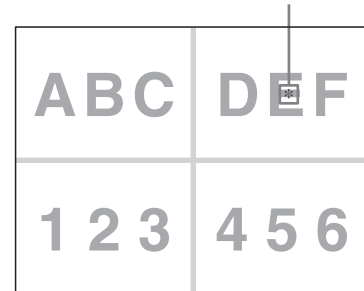

- 4** Press the CLEAR button.
The reduced image in the memory page selected in step 3 is deleted.

Erasing the Screen Display on the Video Monitor

You can erase characters displayed on the video monitor (Q1, A and so on) when, for example, it is hard to see the image that is hidden behind the screen display. The printer operation is the same, regardless of whether those characters are displayed on the video monitor. Since the same characters are displayed in the printer window display, perform operations watching them in the printer window display.

For detailed information on displaying remaining amount of the ink ribbon, see “Displaying the Remaining Amount of the Ink Ribbon” on page 62.

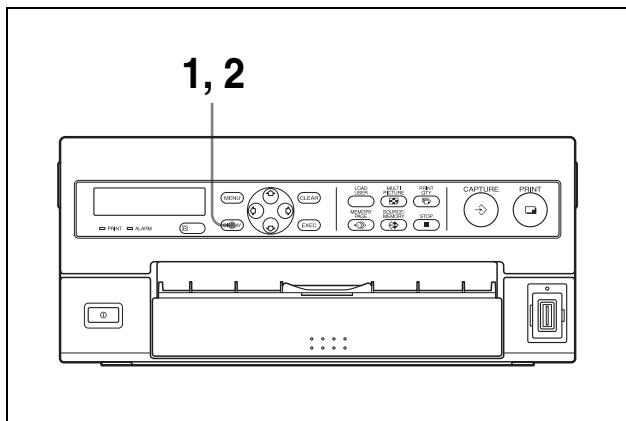

- 1 Press the DISPLAY button. The current setting appears. The video monitor screen is reset to the regular screen after a few seconds.

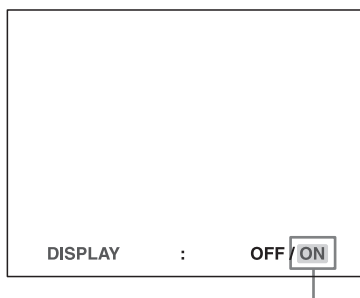

The currently selected setting is lit in green.

- 2 Select OFF. While the screen which appears in step 1 is displayed, press the DISPLAY button repeatedly until the color of OFF turns green on the video monitor, or until OFF is displayed in capital letters in the printer window display.

Each time you press the DISPLAY button, the setting changes in the following sequence: ON → OFF → ON...

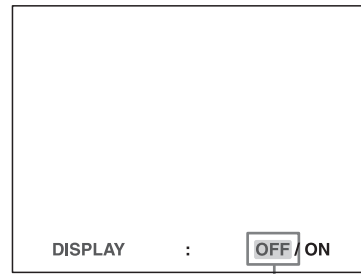

Highlight OFF in green.

To display characters on the video monitor
Select ON.

To perform the setting for the monitor display on the menu

You can also set whether characters are displayed on the video monitor by changing DISPLAY to ON or OFF in the OUTPUT SETUP menu. The setting of the DISPLAY button also changes according to the setting of DISPLAY in the OUTPUT SETUP menu, and vice versa.

When you want to see an image that is hidden below a menu

You can erase the menu temporarily while holding the DISPLAY button down.

Note

The error messages are always displayed regardless of the setting of the monitor display.

Storing Image Data on a USB Flash Memory Device

When a USB flash memory device is inserted into the USB host port on the front of the printer, on-screen image data (which was captured) is stored as JPEG (Joint Photographic Experts Group) image data on the USB flash memory device when you print this captured image data for the first time.

You can see the image data stored in the USB flash memory via a personal data computer equipped with a USB port.

File name of the image

Each time you print image data captured by pressing the PRINT button, the image data is stored as JPEG image data, with a name assigned, in order, from UP_0001 to UP_9999. In the case of reduced images, each reduced image is stored as one file. However, the image data is stored only when it is printed for the first time. Image data printed once is not stored again.

Also, the time stamp is added to the file.

To make printouts with the correct date

The day and time setting is necessary.

For detailed information, see “Setting Date and Time” on page 20.

Storing Image Data on a USB Flash Memory Device

Note

Be sure not to use a USB flash memory device other than a USB flash memory device manufactured by Sony Corporation.

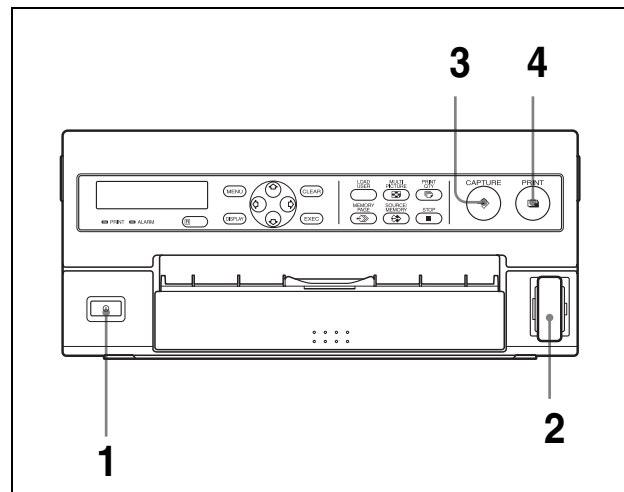

- 1 Turn on the power of the monitor and printer.
- 2 Insert the USB flash memory device into the USB host port.
The access lamp lights. When it goes off, you can start to store image data in the USB flash memory.
- 3 Press the CAPTURE button to capture the image to be printed.
- 4 Press the PRINT button.
The printer starts printing.
At the same time, the image data is stored in the USB flash memory. While it is being written in the USB flash memory, the access lamp is lit. When writing is completed, the access lamp goes off.

To remove the USB flash memory

Whenever the access lamp is lit, the printer is writing data on the USB flash memory device.

If you remove the USB flash memory device while the access lamp is lit, the image data will not be written correctly.

When the message USB MEMORYFULL or USB MEMORY FILE NAME FULL appears

The USB memory is full or the maximum number of images have already been stored, and no further image data cannot be stored on this device.

In this case, delete unnecessary files from the USB flash memory device using a personal computer or use a new USB flash memory.

You can select the printer operation when the USB flash memory device becomes full.

Selecting the Printer Operation When the USB Flash Memory Device Becomes Full

- 1 Display the FUNCTION SETUP menu according to the operation in steps 1 to 3 described in “Deciding which image is displayed on the video monitor screen after capturing an image” on page 33.
- 2 Select IMAGE COPY by pressing \uparrow or \downarrow button.

Highlight IMAGE COPY in green by pressing the \uparrow or \downarrow button

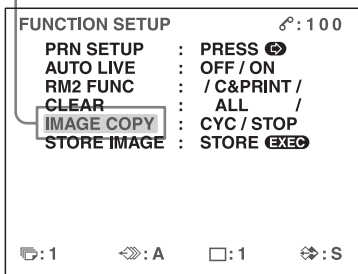

- 3 Select the desired mode by pressing \leftarrow or \rightarrow button.

Highlight desired mode in green by pressing the \leftarrow or \rightarrow button

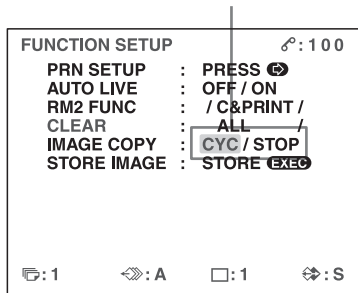

When you want to	Mode
Overwrite data from images with the oldest time stamp when the USB flash memory becomes full or the file number of the most recent image data reaches UP_9999. There is a case where several old files are deleted.	CYC
Stop storing images when the USB flash memory becomes full or the file number of the most recent image data reaches UP_9999. In this case, the error message “USB MEMORY IS FULL” or “The USB Memory File Name End” appears.	STOP

To return to the PRINTER SETUP menu

Select PRN SETUP by pressing the \uparrow or \downarrow button, and then press the \rightarrow button.

To return to the normal screen

Press the MENU button.

Folder in which image data is stored

Image data is stored in the following folder in the printer.

\\SONY\PRINTER\IMAGES

Notes on using the USB host port

- The USB host port supports the USB mass storage class. (However not all types of USB flash memory device are guaranteed with this port.)
- Connecting a USB flash memory device and this port via a hub is not guaranteed.
- The port is USB Full-Speed compliant.
- The file system is FAT 12, 16 and 32.
- When your USB flash memory device has a lock function, unlock it before using it.
- Do not use a USB flash memory device with two or more drives.

When printing reduced images

All reduced images printed are stored as separate image data files.

Notes

- The size of the JPEG file depends on the image data and the type of input signal.
The size of the image data of RGB signals is larger than that of VIDEO or S-VIDEO signals. The sampling rate of the image data is set to a high value because the image data of RGB input signals is a high quality picture. Thus, the image size is larger.
- You cannot make a printout of image data stored in the flash memory by loading it from the USB flash memory device.

- The printer can write image data in the USB flash memory. But the printer is not allowed to load or to delete data from the USB flash memory device.

Making Printouts with File Names

You can make printouts of image data with file names printed on the bottom left side of the printout. File names of all of reduced images are printed. When the printer is set to print make printouts with file names, F is displayed on the left top.

Note

When the printer is set to make printouts with a caption, the comment is printed with priority over the file name. When you want to make printouts with file names, set the function for printing a caption to OFF on the CAPTION menu. For details, see “Making Printouts With a Caption” on page 36.

- 1 Display the LAYOUT SETUP menu according to the operation described in step 1 in “Selecting the memory mode” on page 30.
- 2 Select FILE NAME by pressing the \uparrow or \downarrow button.

Highlight FILE NAME in green by pressing the \uparrow or \downarrow button.

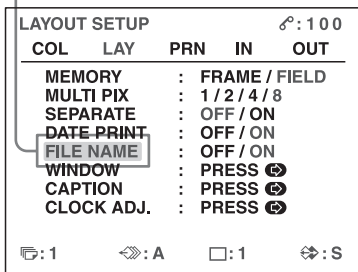

- 3 Decide whether or not printouts will be printed with file names by pressing the \leftarrow or \rightarrow button.

Highlight the desired setting in green by pressing the \leftarrow or \rightarrow button.

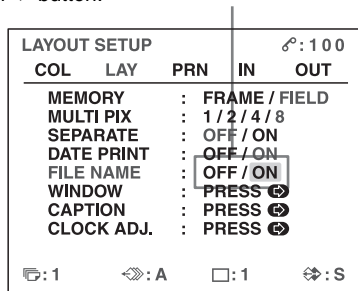

When you want to	Setting
Make printouts without file names.	OFF
Make printouts with file names	ON

- 4 Press the MENU button. The normal screen appears.

File names printed

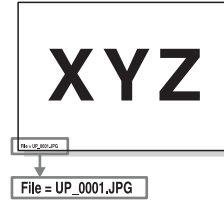

File Name of the printout of a full-size image

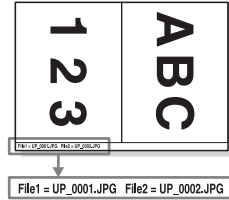

File name of the printout of two reduced images

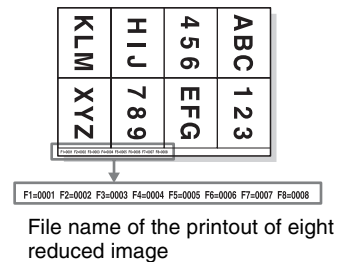
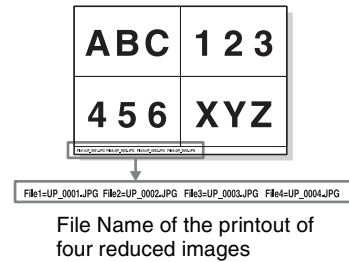

Note

When the message “USB MEMORY FULL. SET NEW STORAGE.” or “USB MEMORY WRITE ERROR” appears, the file printed when these messages appeared may not be written in the USB flash memory device.

Functions That Can be Set on Menus

You can set up the printer to meet various specifications. Once you have adjusted and stored the settings, the printer operates according to those settings until their values are modified. You can set up the printer according to its intended purpose, connected equipment, or your individual preferences.

You can store up to three settings as a set of user settings, called user set 1, 2 and 3.

Functions that can be set on those menus are as follows:

Menu	Functions to be set	Reference pages
COLOR ADJUST	Adjusting the printout color (color intensity and contrast) and sharpness	53
LAYOUT SETUP	Selecting the memory mode	30
	Selecting the type of printout	31
	Selecting whether or not white borders are added to multiple reduced images	35
	Selecting whether or not date is printed together	40
	Selecting whether or not a file name is printed together	46
WINDOW SETUP	Eliminating the black lines produced on the printout	56
CAPTION	Entering a caption	36
CLOCK ADJUST	Setting date and time	20
PRINTER SETUP	Setting the print quantity	26
	Adjusting the tone of the printout	56
	Selecting the print speed	24
SYSTEM SETUP	Adjusting the brightness of the printer window display	62
	Setting the baud rate for computer communication	62
	Selecting whether or not the operation and error tones sound	62
	Compensating for the level of the input signal	52
	Registering user settings	62
USER NAME	Editing the user name	62

Menu	Functions to be set	Reference pages
FUNCTION SETUP	Selecting the image which appears after storing the image into memory, the source image or the memory image	33
	Assigning the function to remote control units connected to the REMOTE 2 connector	60
	Setting the function of the CLEAR button	41
	Selecting printer operation when the USB flash memory device becomes full	45
	Storing or loading image data and all of menu settings to or from a built in memory stick	72
COLOR BALANCE	Adjusting the color balance	57
INPUT SETUP	Selecting the input signal	19
	Compensating for the input signals	52
OUTPUT SETUP	Erasing the screen display	43
	Selecting whether or not information about the ink ribbon is displayed	62
	Selecting the output signal from the printer	52
	Selecting whether the printer synchronizes with the internal sync signal included in channel G of the RGB signals	13
	Matching the video monitor color to the printout color	52

Menu Tree

Normal screen



Press the MENU button.

For reference pages of each menu, see the table on "Functions That Can be Set on Menus" on page 47.

COLOR ADJUST menu

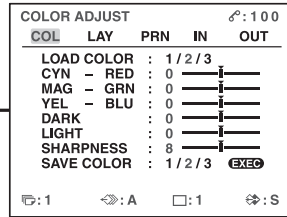

WINDOW SETUP menu

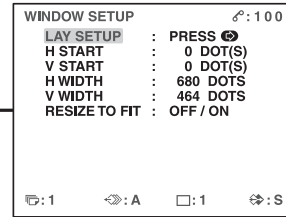

LAYOUT SETUP menu

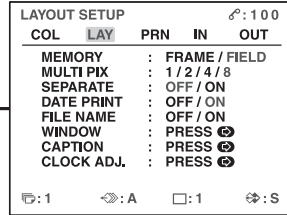

CAPTION menu

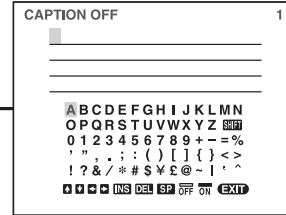

PRINTER SETUP menu

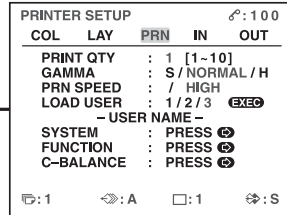

SYSTEM SETUP menu

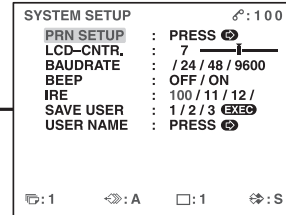

USER NAME menu

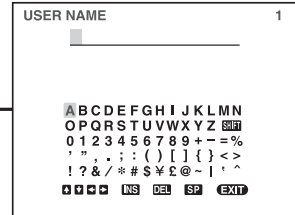

INPUT SETUP menu

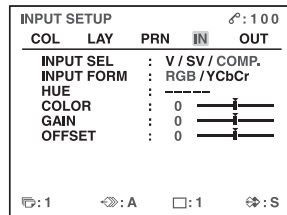

FUNCTION SETUP menu

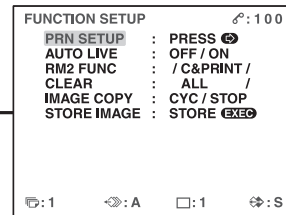

OUTPUT SETUP menu

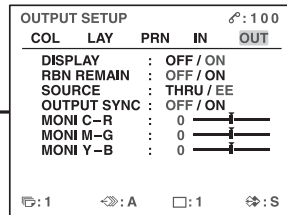

COLOR BALANCE menu

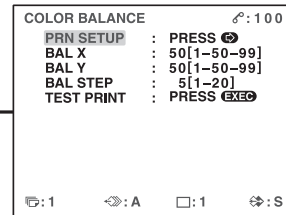

Adjustment

Basic Menu Operations

In this section, in addition to the video monitor display, the printer window display is also introduced.

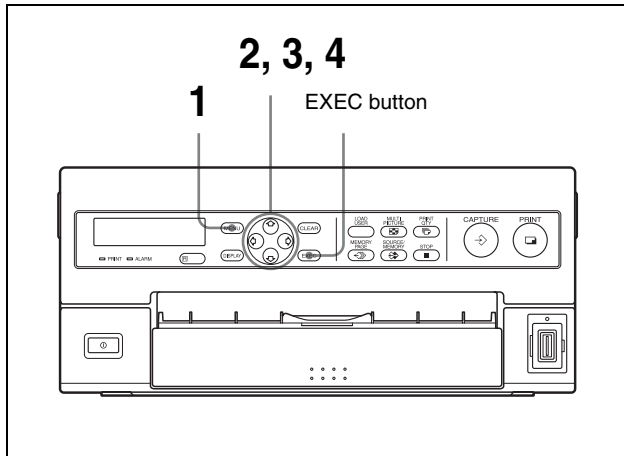

- 1 Press the MENU button.
The previously selected menu appears.

The menu currently displayed on the screen is lit in green.

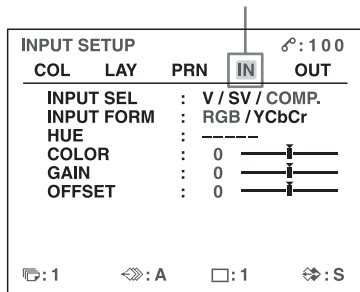

The name of the menu currently displayed appears in capital letters.

When the cursor (that is highlighted in green) is not positioned on the top line: Move the cursor to the top line by pressing the \leftarrow or \rightarrow button.

The cursor is not positioned on the top line.

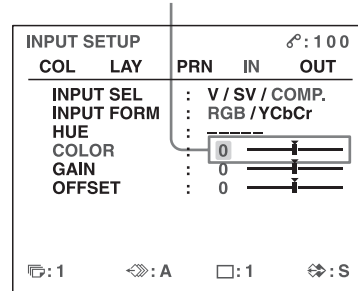

- 2 Display the desired menu by pressing the \leftarrow or \rightarrow button.

Example: To display the PRINTER SETUP menu

Highlight PRN in green by pressing the \leftarrow or \rightarrow button, then the PRINTER SETUP menu appears.

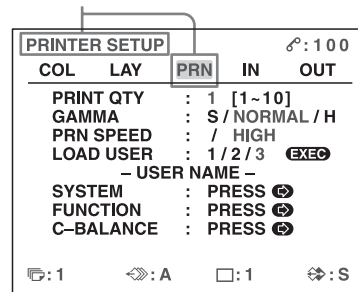

Display PRN in capital letters by pressing the \leftarrow or \rightarrow button. The PRINTER SETUP appears.

- 3 Select the desired item by pressing the \leftarrow or \rightarrow button.

Example: To select PRN SPEED on the PRINTER SETUP menu

Highlight PRN SPEED in green by pressing the \leftarrow or \rightarrow button.

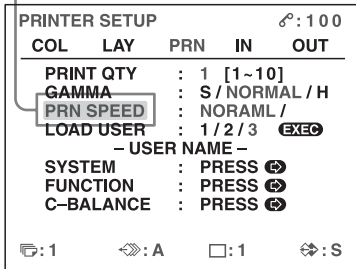

Press the \leftarrow or \rightarrow button until PRN SPEED appears.

Example: To select HIGH of the PRN SPEED item on the PRINTER SETUP menu

Highlight HIGH in to green by pressing the \leftarrow or \rightarrow button.

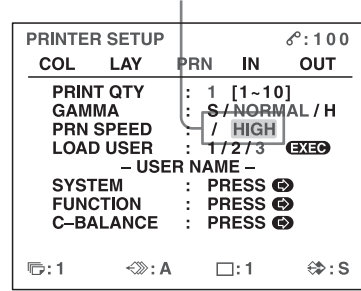

Display HIGH in capital letters by pressing the \leftarrow or \rightarrow button.

- 4 Change the setting by pressing the \leftarrow or \rightarrow button.

To change the selection:

Switch the desired selection to green by pressing the \leftarrow or \rightarrow button.

Note

When / is displayed at both ends of a selection or at either the right or left end, there are more selections in this direction. Press the \leftarrow or \rightarrow button to display more selections.

When - - - - is displayed at the selection:
 - - - - is displayed when changing the selection is ineffective. The following table lists the case where the selection is ineffective.

Selected item	Item can not to be changed (when - - - - is displayed at the selection)
1 is selected for MULTI PIX on the LAYOUT SETUP menu.	SEPARATE (LAYOUT SETUP menu)
COMP is selected for INPUT SEL on the INPUT SETUP menu.	HUE (INPUT SETUP menu)
S-VIDEO or VIDEO is selected for INPUT SEL on the INPUT SETUP menu.	INPUT FORM (INPUT SETUP menu)

To change the setting values:

Press the \leftarrow or \rightarrow button to decrease or increase the setting values.

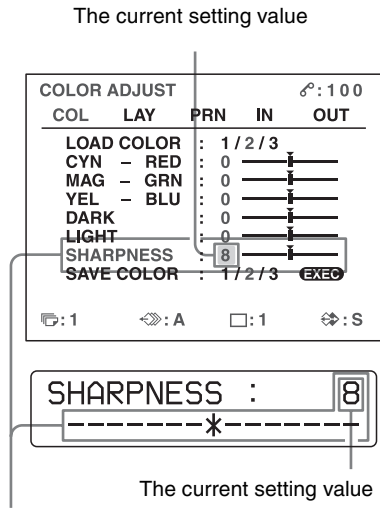

The setting value increases every time you press \rightarrow button.
 The setting value decreases every time you press the \leftarrow button.

To reset the values to factory setting:

Position the cursor at the item to be reset to defaults, then press the \leftarrow and \rightarrow buttons simultaneously.

When there are sub menus:

When there are sub menus, PRESS [>] is displayed on the selection part of the menu. Select the desired sub menu by pressing the \uparrow or \downarrow button, then press the \rightarrow button.

Example: On the PRINTER SETUP menu

To display the SYSTEM SETUP sub menu:
 Select SYSTEM by pressing the \uparrow or \downarrow button, then press the \rightarrow button.

The SYSTEM SETUP menu appears.

Highlight SYSTEM in green by pressing the \uparrow or \downarrow button, then press the \rightarrow button.

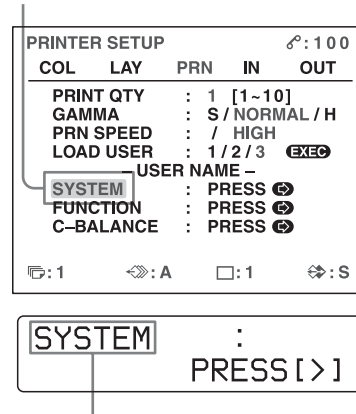

Press the \uparrow or \downarrow button until SYSTEM appears, then press the \rightarrow button.

To return from the sub menu:

Select the menu on the top line, then press the \rightarrow button.

Highlight PRN SETUP in green by pressing the \uparrow button, then press the \rightarrow button.

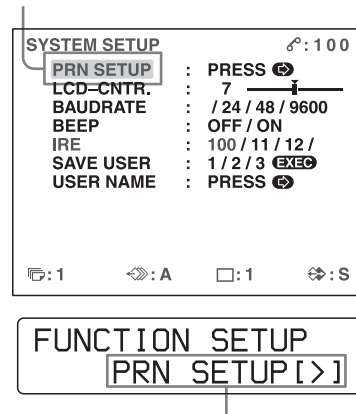

Press the \uparrow button until PRN SETUP appears, then press the \rightarrow button.

Adjusting the Color and Picture Quality

Compensating for the Input Signals

A video image recorded under poor conditions may be of poor color quality. If the signal is an NTSC or PAL composite video signal or separate luminance (Y) and chrominance (C) signals, you can correct the color and level of the input signal to a certain extent.

Note

You cannot adjust an image once it has been captured in memory. If you want to make adjustments, capture that image again, after making the adjustment.

Confirmation

When the memory image is displayed on the video monitor, press the SOURCE/MEMORY button to display the image from the video source.

Items to be used for compensating for the input signals

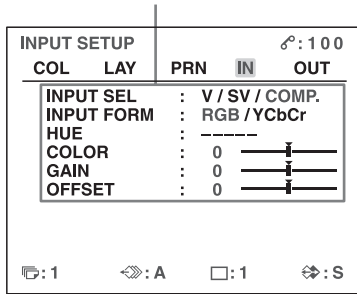

of an NTSC and PAL composite video signal or a separated luminance (Y) and chrominance (C) signal.

- b) On a setting of step -14, OFF appears and the image, displayed on the video monitor, becomes black and white.
- c) When a component (RGB or YCbCr signal) signal is input, you cannot adjust OFFSET below 0.

Adjusting the contrast of printouts

When you want to change the contrast of printouts without changing the contrast of the video monitor, compensate for the level of the input signal using the IRE item in the SYSTEM SETUP menu.

Items to be used when adjusting the contrast of printouts

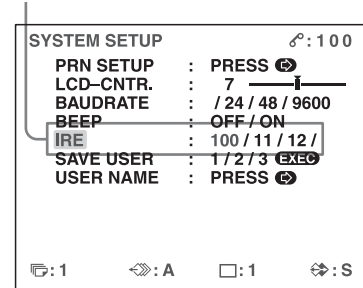

The selected IRE is displayed in three digits.

When	IRE value (the selected IRE is displayed in 4 digits.)
Resetting to the standard adjustment	10 → 100
The printout is a little whitish.	11 → 110
The printout is whitish.	12 → 120
The printout is very whitish.	13 → 130

To adjust the color intensity, hue, contrast and brightness

Adjustment	Menu adjustment item	Button to be pressed and result of the operation	
		↵ button	⇒ button
Hue	HUE ^{a)}	The hue becomes purplish.	The hue becomes greenish.
Color intensity	COLOR ^{b)}	The color intensity weakens.	The color intensity strengthens.
Contrast	GAIN	The contrast weakens.	The contrast strengthens.
Brightness	OFFSET ^{c)}	Becomes darker.	Becomes brighter.

a) Adjust the color such that skin tones appear natural. For the HUE adjustment, you can correct the color intensity and hue

Notes

- Do not compensate for the input signal too much. Doing so results in the whole of the printout becoming dark.
- To have the adjustment result reflected in the printout, you need to capture a new image.

Matching the Video Monitor Color to the Printer Color

To match the color of the monitor image to that of the printout, adjust the monitor and printer colors such that the monitor color is the same as that of the printout. The printer outputs either of two kinds of video signals based on the printer settings.

- EE (E to E): Signals are output to the monitor after being processed by the printer's circuitry.
- THRU (THROUGH): Signals are output to the monitor as is.

Adjustment on the video monitor

The monitor color may not be adjusted correctly even if the printer color is correctly adjusted. Check the color of the video monitor before adjusting the printout color. In such a case, use the THRU signal by setting SOURCE to THRU on the OUTPUT SETUP menu or turning off the power of the printer to send out the through signal from the video equipment to the video monitor.

After adjusting the color of the video monitor using video monitor controls, adjust the color of the printer's output signal.

Adjustment on the printer

Note

This adjustment is performed to adjust the color of the printer output signal when the monitor color is unsatisfactory. This adjustment does not affect the printout itself. To adjust the color of the printout, see "Adjusting the Printout Color" on page 53.

- 1 Display the OUTPUT SETUP menu.

OUTPUT SETUP menu

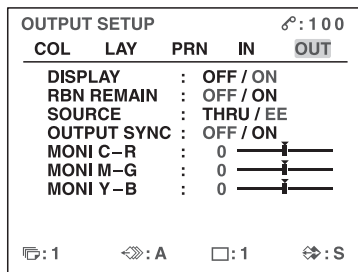

- 2 Select SOURCE by pressing the \uparrow or \downarrow button.
- 3 Select EE by pressing the \leftarrow or \rightarrow button.
- 4 Press the MENU button.
The regular screen appears.
- 5 Capture a new image in memory and make a printout.
Adjust the settings on the printer side by comparing the printout with the image on the monitor, as follows.
- 6 Display the OUTPUT SETUP menu again.
- 7 Adjust the monitor while comparing the printout with the image on the monitor.

Menu adjustment item	When you want to	Button to be pressed	Adjustment direction on the menu
MONI C-R	Make the screen more reddish.	\rightarrow button	Toward R (red)
	Make the screen become cyan (blue).	\leftarrow button	Toward C (cyan)
MONI M-G	Make the screen more greenish.	\rightarrow button	Toward G (green)
	Make the screen become magenta (pink).	\leftarrow button	Toward M (magenta)
MONI Y-B	Make the screen more bluish.	\rightarrow button	Toward B (blue)
	Make the screen more yellowish.	\leftarrow button	Toward Y (yellow)

Select the desired item, then perform the adjustment.

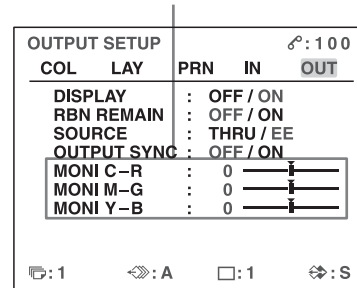

Adjusting the Printout Color

You can adjust the printout quality by adjusting the color intensity, printout contrast and sharpness and tone (GAMMA) of the printout.

Adjusting the color intensity, contrast and sharpness

You can store up to three types of settings and manage these settings using the LOAD COLOR numbers 1, 2 and 3. The color intensity, picture contrast and sharpness of a printout are determined by recalling one of the three settings according to their LOAD COLOR numbers. This is useful when you are using more than one item of video equipment, each having different characteristics, when you want to print images having different color qualities and picture contrast, or when multiple users access a single printer.

Also, you can make a printout using temporarily set values, without clearing the stored adjustment values. Perform the adjustments while viewing the images captured in memory.

1 Display the COLOR ADJUST menu.

COLOR ADJUST menu

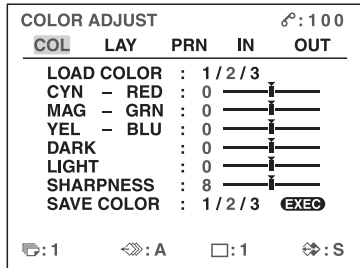

2 Select the LOAD COLOR number of the values to be adjusted or to be modified by pressing the ⇐ or ⇒ button.
When modifying, you can preserve the original settings. (See “To retain the originally set value” on page 55.)

3 Adjust the printout color.

Items to be used for adjusting the color intensity

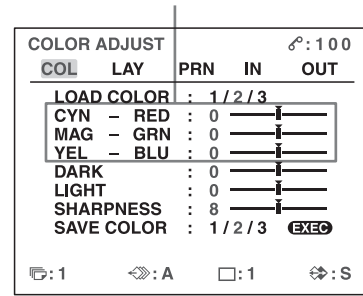

Items to be used for adjusting the contrast

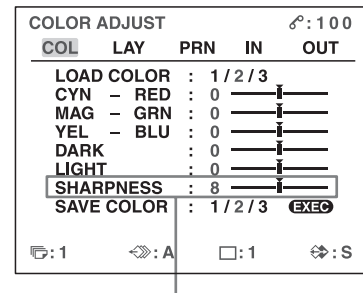
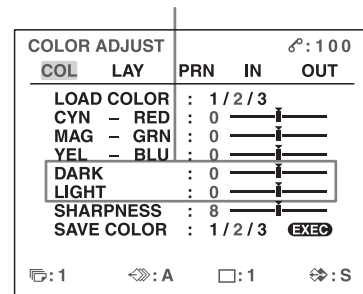

Items to be used for adjusting the sharpness/interpolation

To adjust the color intensity (RED/GREEN/BLUE)

The RED, GREEN and BLUE color component settings are divided into 15 steps, from -7 to +7, indicated by a value and graph. The center of the graph (0) corresponds to the standard setting.

Menu Adjustment item	When you want to	Button to be pressed	Adjustment direction on the menu
CYN-RED	Make the image reddish.	⇒ button	Toward RED
	Make the image cyan.	⇐ button	Toward CYN (cyan)

Menu Adjustment item	When you want to	Button to be pressed	Adjustment direction on the menu
MAG-GRN	Make the image greenish.	⇒ button	Toward GRN (green)
	Make the image magenta (pink).	⇔ button	Toward MAG (magenta)
YEL-BLU	Make the image bluish.	⇒ button	Toward BLU (blue)
	Make the image yellowish.	⇔ button	Toward YEL (yellow)

To adjust the contrast (DARK/LIGHT)

The contrast settings are divided into 15 steps, from -7 to +7, indicated by a value and graph. The center of the graph (0) corresponds to the standard setting.

Adjustment item	When you want to
DARK	Adjust the dark area of an image.
LIGHT	Adjust the light area of an image.

To adjust the sharpness

You can set the sharpness to any of 15 steps from 1 to 15. A setting of step 8 corresponds to the standard sharpness (default setting).

When you want to	Content of settings
Make a soft outline.	To the left (toward step 1)
Make a normal outline.	Centered (step 8)
Make a sharp outline.	To the right (toward step 15)

Once you have changed the value

Once you have changed the value, TEMP (TEMPORARY) appears on the menu screen. TEMP indicates that the settings are temporary and have not yet been stored. If you turn off the power of the printer while TEMP is displayed, the adjusted values are not stored.

- 4 Select the SAVE COLOR number to which new settings are to be stored using the SAVE COLOR item.

To retain the originally set value

Select a SAVE COLOR number which is different from the LOAD COLOR number selected in step 2.

- 5 Press the EXEC button. The settings are registered in the SAVE COLOR number selected in step 4.

TEMP disappears from the menu.

To continue settings for another LOAD COLOR number: Repeat steps 2 to 5.

To finish the setting: Press the MENU button. The regular screen appears.

To copy the settings made for one LOAD COLOR number to another LOAD COLOR number

- 1 Select the source LOAD COLOR number for which the settings to be copied are stored on the COLOR ADJUST menu.
- 2 Select the target SAVE COLOR number to which data is to be copied.
- 3 Press the EXEC button. Settings stored for the LOAD COLOR number selected in step 1 are copied to the SAVE COLOR number selected in step 2.

To recall the LOAD COLOR number in which printout color settings (color intensity, contrast and sharpness) are stored

Switch the desired LOAD COLOR number to green on the COLOR ADJUST menu. On the printer window display, display the desired LOAD COLOR number. The settings of the currently selected LOAD COLOR number are displayed. The printout is made according to the setting of the selected LOAD COLOR number as long as you do not modify those settings.

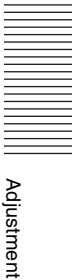

Adjusting the tone of the printout

You can adjust the tone so that the details in the white or black part are clearly printed.

- 1 Display the PRINTER SETUP menu.

PRINTER SETUP menu

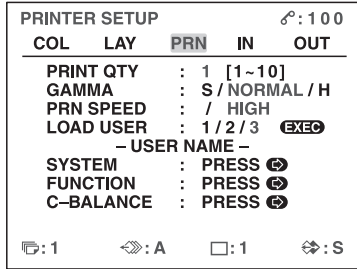

- 2 Select GAMMA, and then the desired tone. The selected tone is spelled out.

When you want to	Setting
Make a printout of an image where there are a lot of white or light-colored areas.	S → SOFT
Make a printout of a normal image.	N → NORMAL
Make a printout of an image where there are a lot of black or dark-colored areas.	H → HARD

When a Black Frame or Lines Show up on the Printouts

When you print an image that is narrower or wider than the standard screen size, a black frame may be printed or the image may be partially cut. Or, a black line may show up on the printout even though it does not appear on the video monitor. Any portion for which there is no video signal is printed in black. This may occur when you make printouts after connecting a different video source or play back using different video software. In such a case, you can adjust the printout area by moving the screen either horizontally or vertically.

- 1 Display the WINDOW SETUP menu from the LAYOUT SETUP menu.

- 2 Perform adjustments according to the printout obtained by using the V START, V WIDTH, H START and H WIDTH items.

Item to be used for eliminating the vertical line at the right side

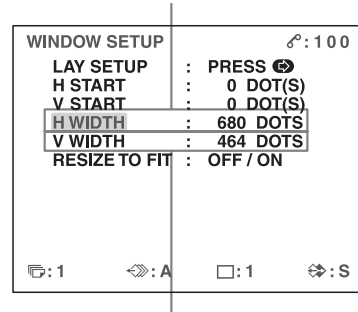

Item to be used for eliminating the horizontal line on the bottom

Item to be used for eliminating the vertical line at the left side

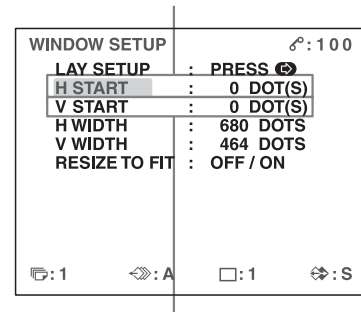

Item to be used for eliminating the horizontal line at the top

When a horizontal black line is produced on the printout

To eliminate a horizontal black line produced at the top:

Adjust the top position of the image to be printed using the V START item.

Note

It is alright if a black line appears at the bottom while you adjusting the top. You can eliminate it using the V WIDTH item.

To eliminate a horizontal black line produced at the bottom:

Adjust the bottom position of the image to be printed using the V WIDTH item.

When a vertical black line is produced on the printout

To eliminate a vertical black line produced on the left side:

Adjust the left position of the image to be printed using the H START item.

Note

It is alright if a black line appears on the right side while you adjusting on the left side. You can eliminate it using the H WIDTH item.

To eliminate a vertical black line produced on the right side:

Adjust the right position of the image to be printed using the H WIDTH item.

To reset the values to defaults

For H START, H WIDTH, V START and V WIDTH items, you can reset the values to defaults in pairs.

To reset the values for vertical settings, position the cursor at either V START or V WIDTH, and then press the ← and → buttons simultaneously.

To reset the values for horizontal settings, position the cursor at either H START or H WIDTH, and then press the ← and → buttons simultaneously.

	H WIDTH	H START	V WIDTH	V START
Defaults	NTSC/PAL: 680	NTSC/PAL: 0	NTSC:464, PAL: 560	NTSC/PAL: 0

To check the adjustment result

Print to check that no black frame appears on the printout, that the image is not partially cut, and that no black line appears.

Fitting the Printout to the Paper

- 1 Display the WINDOW SETUP menu from the LAYOUT SETUP menu.

- 2 Select RESIZE TO FIT.

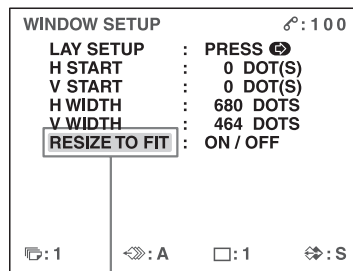

Highlight RESIZE TO FIT in green.

When you want to	Setting
Print the image with the printout area adjusted on the WINDOW SETUP menu	OFF
Print the adjusted image to fit to the paper	ON

Adjusting the Color Balance

You should use the ink ribbon and paper that are contained in the same package as a pair. The color balance may differ depending on each pair. It is recommended that you adjust the color balance each time you load a new set of ink ribbon and paper.

Before adjusting the color balance

Reset all items on the COLOR ADJUST menu to defaults. (See “Adjusting the Printout Color” on page 53.)

- 1 Display the COLOR BALANCE menu from the PRINTER SETUP menu.

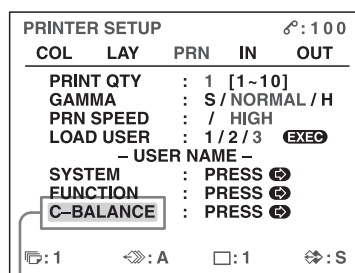

Select C-BALANCE, then press the → button.

The highlighted area on the COLOR BALANCE menu will be printed to be used for adjusting the color balance.
You can move this area to any place on the video monitor.

The area that will be captured in memory.
(This area is highlighted and is two third the size of the whole screen.)

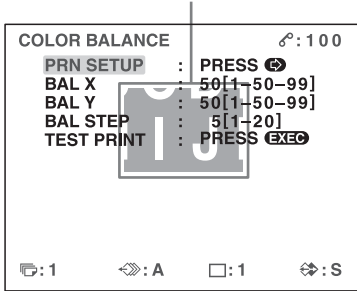

When you adjust the color balance for the first time after you purchase the printer, the values of BAL X, BAL Y and BAL STEP are set to 50, 50 and 05 at the factory setting.

When you have adjusted the color balance already, the values adjusted previously are displayed on the COLOR BALANCE menu.

The currently adjusted values of BAL X, BAL Y and BAL STEP
On this COLOR BALANCE menu, the default values (factory settings) are displayed.

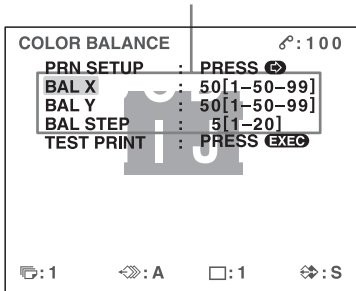

To reset the values to the factory setting (50/50/05)

Select each item by pressing the or button, then press the and buttons at the same time. The currently selected item is reset to the default.

2 Decide the position of the source image to be used for adjusting the color balance.

To decide the position of the source image, move the highlighted area by pressing the , , or button while holding down the DISPLAY button.

Move the highlighted part to the desired image position by pressing the , , or button while holding down the DISPLAY button. (The COLOR BALANCE menu disappears temporarily.)

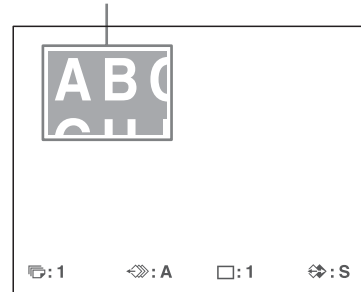

3 Press the CAPTURE button. The image captured in memory appears.

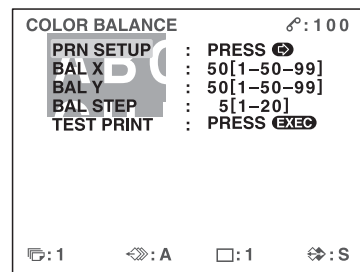

4 Select TEST PRINT by pressing the or button, then press the EXEC button. Nine identical images of the position selected in step 2 are printed on a sheet of paper as a test print. Each image has a different color balance.

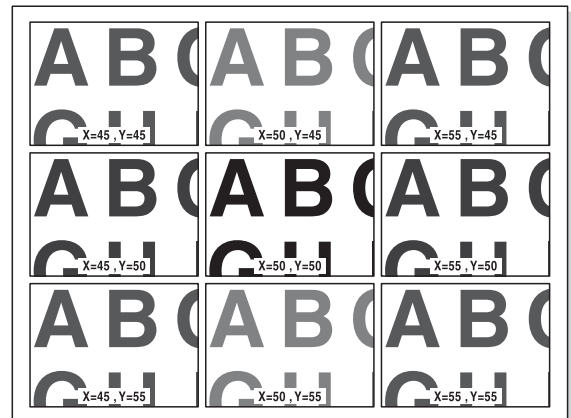

Example of the actual color change in the test print

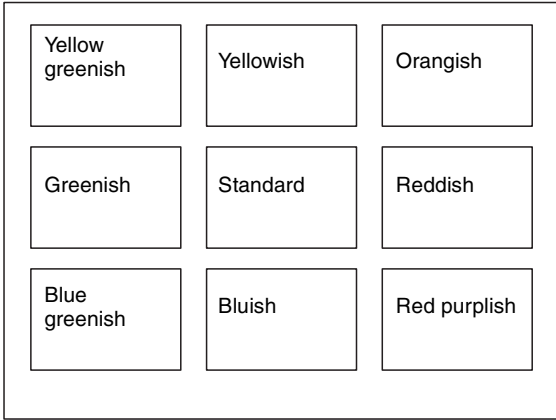

- 5 Select the image which has the best color balance among the nine images. If you want to change the color balance after you see the printout, adjust the color balance again, referring to “To readjust the color balance” on page 59.
- 6 Display the values of BAL X and BAL Y corresponding to the ones of the image selected in step 5 by using the \leftarrow or \rightarrow button. Example: When the color balance (55 & 45) of the image printed on the top right is the best:

Display 55 for BAL X and 45 for BAL Y by pressing the \leftarrow or \rightarrow button.

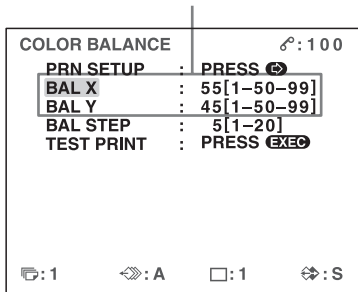

The color balance of the printed image has been adjusted to the values selected in step 5.

To readjust the color balance

When the desired color balance cannot be obtained in step 5, readjust the color balance. You can also perform fine adjustment following the same operation procedures.

- 1 Display the values of BAL X and BAL Y of the image which is the most appropriate among nine images.

In this case, you can perform either fine adjustment or a rough adjustment by changing the value of BAL STEP.

To perform fine adjustment

To perform color balance adjustment within the current color balance range, reduce the value of BAL STEP.

If you change BAL STEP from 05 to 03, the color balances of the test print are changed as illustrated.

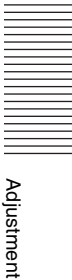
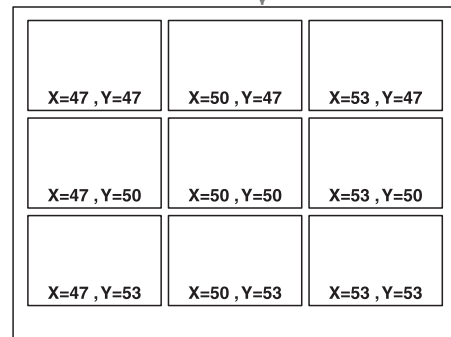
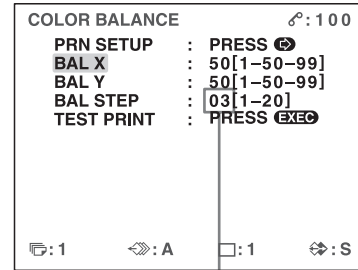

Adjustment

To perform rough adjustment

To perform color balance adjustment beyond the current color balance range, increase the value of BAL STEP.

If you change BAL STEP from 05 to 10, the color balances of the test print are changed as illustrated.

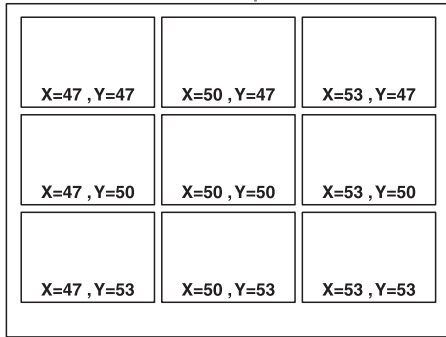
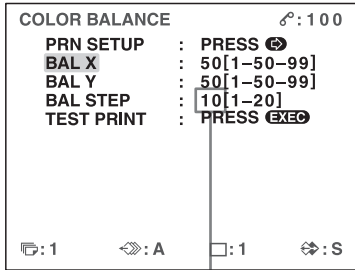

Adjustment

- 2 Make a test print by repeating steps 2, 3 and 4 in “Adjusting the Color Balance” on page 57.
- 3 Select the image with the best color balance among the 9 images, if you can decide.
If there is not the image with the best color balance, repeat steps 1 and 2 until you have obtained the best color balance.
- 4 Go back to step 6 in “Adjusting the Color Balance” on page 57.

Making Various Settings

Assigning Functions to the Remote Control Unit

You can control a printer using the RM-91 Remote Control Unit (not supplied) or FS-24 Foot Switch (not supplied) connected to the REMOTE 2 connector on the rear panel of the printer.

Using the menu, you can assign the desired functions to the remote control unit connected to the REMOTE 2 connector.

In addition, the printer can be remotely controlled by a pulse signal input to REMOTE 2. (See page 66.)

Also, you can control the printer using a personal computer.

- 1 Display the FUNCTION SETUP menu from the PRINTER SETUP menu.

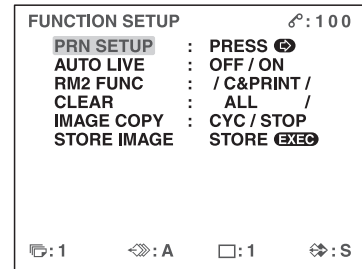

- 2 Select the desired RM 2 FUNC item, then assign a function.

Function to be selected	Operation
CAPTURE	Has the same function as the CAPTURE button on the printer.
PRINT	Has the same function as the PRINT button on the printer.
C & PRINT ^{a)} (CAPTURE & PRINT)	Captures an image to a memory page where there is not a queued image waiting to be printed and print them whenever you press the switch. If you press the switch while printing is being performed, the selected image is queued, with the queued image being printed once printing has been completed.

Function to be selected	Operation
CYCLIC-C ^{b)} (CYCLIC CAPTURE)	Captures images to memory pages where there are no queued images. It does this cyclically whenever you press the switch. The printer continues to capture images, replacing the one previously captured with a new one.
CAP-STOP ^{b)} (CAPTURE STOP)	Captures images in a memory page whenever you press the switch of the remote control unit. Once images have been captured in all the memory pages, the printer stops capturing images and the message HIT ANY KEY appears.
BACK-SP ^{a)}	The cursor (green pointer) returns to its former position whenever you press the switch when the type of multiple reduced images has been selected.
POINTER+	The cursor (green pointer) moves to the next position whenever you press the switch when the type of multiple reduced images has been selected.
STOP	Stops printing after the current printing operation is finished whenever you press the switch of the remote control unit.
CAP/SRC (CAPTURE/ SOURCE)	When the memory image is displayed, the source image appears when you press the switch. When the source image is displayed, the image is captured in memory when you press the switch of the remote control unit. However, the memory page is not changed. The previously captured image is replaced with the new one.
CAP/S PAGE ^{b)} (CAPTURE/SOURCE PAGE)	When the memory image is displayed, the source image appears when you press the switch of the remote control unit. When the source image is displayed, the image is captured in memory when you press the switch. The memory page is also changed. The captured image is not printed.

Function to be selected	Operation
PRINT & PAGE	Starts to print when you press the switch if the image has been captured in the memory, and at the same time moves to the next memory page. If the image has not been captured in the memory page, the printer does not work correctly when you press the switch of the remote control unit.
SRC & CAP (SOURCE & CAPTURE)	When you press and hold down the switch of the remote control unit, the source image appears. When you release the switch, the image showing at the instant you release the switch is captured. The memory page is not changed.
SRC & C PAGE ^{b)} (SOURCE & CAPTURE PAGE)	When you press and hold down the switch of the remote control unit, the source image appears. When you release the switch, the image showing at the instant you release the switch is captured. Then, the memory page is changed to the next memory page. The captured image is not printed.

- a) When you use the remote control unit with this function, confirm that the source image is displayed on the video monitor. If not, press the SOURCE/MEMORY button so that the source image will be displayed. When multiple reduced images are being captured, after the last image is captured, the printer prints the captured image (or queues printing), then the printer goes to the next memory page.
- b) When multiple reduced images are being captured, after the last image is captured, the printer goes to the next memory page.

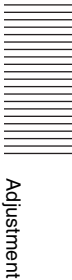

Adjustment

Adjusting the Brightness of the Printer Window Display

When it is hard to read the contents of the printer window display, adjust the brightness using the menu.

- 1 Display the SYSTEM SETUP menu from the PRINTER SETUP menu.
- 2 Select the LCD-CNTR. item, then adjust the brightness of the printer window display.

Adjust the brightness by pressing the \leftarrow or \rightarrow button.

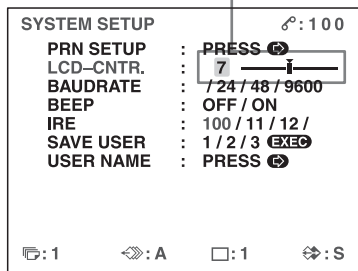

Selecting Whether the Operation and Error Tones Sound

Whenever you press a button on the front door, the operation tone sounds (one time). When an error occurs, the alarm tone sounds (three times). You can turn these tones on and off using the menu.

- 1 Display the SYSTEM SETUP menu from the PRINTER SETUP menu.
- 2 Select the BEEP item, then select whether or not the operation and error tones sound by pressing the \leftarrow or \rightarrow button.

When you want to	Selection
Sound the tones.	ON
Disable the tones.	OFF

Setting the Baud Rate

When controlling the printer with a computer connected to the printer's RS-232C connector, select the appropriate baud rate. For details, contact your nearest Sony dealer.

- 1 Display the SYSTEM SETUP menu from the PRINTER SETUP menu.

- 2 Select the BAUDRATE item, then select the desired baud rate by pressing the \leftarrow or \rightarrow button.

Baud rate (bps)	Baud rate displayed on the menu. (The display changes from first two digit indication to four digit indication.)
1200	12 → 1200
2400	24 → 2400
4800	48 → 4800
9600	96 → 9600

Displaying the Remaining Amount of the Ink Ribbon

You can always display the remaining amount on the video monitor.

Note

Use the ribbon remaining display as a criterion.

- 1 Display the OUTPUT SETUP menu.
- 2 Select the RBN REMAIN item, then select whether or not the type of ink ribbon and the remaining amount are to be displayed on the monitor.

When you want to	Setting
Display the remaining amount.	ON
Erase the information about the remaining amount of the ink ribbon.	OFF

Ink ribbon information

Icon of ink ribbon
When the ink ribbon runs out or is not loaded, the message "SET RIBBON" appears.

Number of printouts that can be made with the ribbon

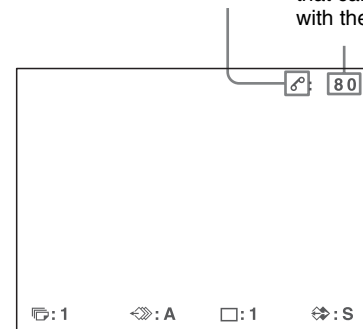

Registering a User Set

You can store up to three settings of all the printer specifications set or adjusted by using the buttons or the

menu, and store those settings as a user set. The printer retains these settings - even if you turn off the power. Thus, different operators can make printouts with different settings by recalling the appropriate user set. If the data of the recalled user set is modified, the printer operates according to the modified data. In such a case, the modified data remains effective until another user set is recalled on the PRINTER SETUP menu, even if you turn off the power. After you finish all of the required settings, proceed as follows to register them as a user set.

- 1 Display the SYSTEM SETUP menu from the PRINTER SETUP menu.
If you want to name a user set, go to step 2.
If you do not want to name a user set, go to step 4.
- 2 Select the USER NAME item, then press the ⇨ button.
The USER NAME menu appears.

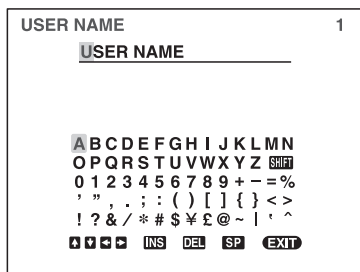

For detailed information on how to enter characters, see “Entering a Caption” on page 37. You can use up to 16 characters.

- 3 Select EXIT by pressing the ⇧, ⇩, ⇨ or ⇩ button on the USER NAME menu, then press the EXEC button.
The user name is stored, and the SYSTEM SETUP menu appears again.
- 4 Select the SAVE USER item, then select the desired user set number.
- 5 Press the EXEC button.
All data currently set and adjusted are registered in the user set number selected in step 4.
When you name a user set in step 2, the user name is also registered at the same time.

The printer operates according to this registered data unless you recall another user set. Also, if you modify the settings, the modified data remains effective until another user set is recalled, even if you turn off the power.

To make another user set

Perform all required settings and adjustments using the menus, then register them with another user set number.

To recall the user set and print

Select the desired user set by using the LOAD USER item on the PRINTER SETUP menu, then press the EXEC button to execute the selected user set. The printer operates according to the recalled user set. If you modify the set value, the printer operates according to the modified data until you recall another user set.

To retain the originally set values

Example: Modify the settings made for user set 1. Retain the original settings of user set 1 and register the modified set values as user set 2.

- 1 Select user set 1 from the LOAD USER item on the PRINTER SETUP menu.
- 2 Press the EXEC button to execute the selected user set 1.
- 3 Modify the recalled set values.
- 4 Select 2 from the SAVE USER item on the SYSTEM SETUP menu.
- 5 Press the EXEC button.
The set values, modified in step 3, are registered as user set 2.

To copy the existing user set

You can copy an existing user set to another user set number.

- 1 Select the source user set number from the LOAD USER item on the PRINTER SETUP menu.
- 2 Press the EXEC button to execute the selected user set.
- 3 Select the target user set number with SAVE USER on the SYSTEM SETUP menu.
- 4 Press the EXEC button.
The set values of the source user set, selected in step 1, are copied to the target user set number selected in step 3.

Precaution

Safety

- Operate the printer using the power source specified in “Specifications” on page 65.
- Be careful not to damage the AC power cord by placing or dropping heavy objects on it; it is dangerous to use the unit with a damaged AC power cord.
- If you do not intend to use the unit for a long time, disconnect the AC power cord.
- Unplug the AC power cord by grasping the plug, not the cable itself.
- Do not disassemble the unit.
- Do not remove the cover. There is a danger of electric shock from the internal parts.
- Be careful not to spill water or other liquids on the unit, or to allow combustible or metallic material to enter the cabinet. If used with foreign matter in the cabinet, the unit is liable to fail, or present a risk of fire or electric shock.
- Ventilation holes are provided to prevent the unit from overheating. Be careful not to obstruct them with other units or by covering the unit with a cloth, etc.
- If the unit malfunctions or if a foreign body falls into the cabinet, disconnect the AC power cord immediately and consult your Sony service facility or your Sony dealer.

Installation

- Avoid placing the unit in a location subject to:
 - mechanical vibration
 - high humidity
 - excessive dust
 - direct or excessive sunlight
 - extremely high or low temperatures
- Do not use other electronic equipment near the unit. The unit will not work properly in strong electromagnetic fields.
- Do not place a heavy object such as a monitor on the printer.

Condensation

- If the printer is subject to wide or sudden changes in temperature, such as when it is moved from a cold room to a warm room or when it is left in a room with a heater that tends to produce large amounts of moisture, condensation may form inside the printer. In such cases the printer will probably not work properly,

and may even develop a fault if you persist in using it. If condensation forms, turn off the power and leave the printer to stand for at least one hour.

- If the printing pack is subjected to wide or sudden changes in temperature, condensation may form on the ink ribbon or paper. This will cause the printer to malfunction. Also, if the printing pack is used in this state, spots are likely to appear on the printout. Therefore, avoid storing the printing pack in locations subject to wide or sudden changes of temperature.
- To store a half-used printing pack, replace it in its original packing and reseal the package. If possible, keep the sealed printing pack in a cool, dark location. To subsequently use the printing pack, place it, in its sealed package, in a warm room for several hours. Doing so prevents condensation from forming when the printing pack is removed from its package.

Location

To prevent internal heat built-up, leave enough room around the printer for air to circulate through the vents on the left hand side and top of the cabinet.

Before Transporting the Printer

Before transporting the printer, remove ink ribbon cartridge and paper tray and then put them back into their original packing. Transporting the printer with the supplied accessories still installed may cause malfunctions.

Cleaning

Note

Be sure to turn off the power of the printer and disconnect the AC power cord from the wall outlet before cleaning.

Cleaning the cabinet

Clean the cabinet, panel and controls with a soft dry cloth, or a soft cloth lightly moistened with a mild detergent solution. Do not use any type of solvent, such as alcohol or benzine, which may damage the finish.

Ink Ribbon and Paper



Do not re-use

Doing so may result in malfunction and negatively affect printing results.

Both paper and an ink ribbon are necessary for printing. Use the ink ribbon with the paper contained in the same package.

UPC-55 Color Printing Pack

Contains color ink ribbon cartridge and paper.
Color ink ribbon for 100 sheets, 2 rolls
Paper, 1 package (100 sheets) x2

Note

If the paper has been exhausted, replace the ink ribbon together with the paper.

Specifications

Power requirements

100 to 120 V AC, 50/60 Hz
(for 100 to 120 V AC users)

220 to 240 V AC, 50/60 Hz
(for 220 to 240 V AC users)

Input Current 2.8 A max. at 25 °C
(for 100 to 120 V AC users)
1.2 A max. at 25 °C
(for 220 to 240 V AC users)

Operating temperature

5 °C to 35 °C (41°F to 95°F)

Operating humidity

20% to 80% (no condensation allowed)

Operating pressure

700 hPa to 1,060 hPa

Storage and transport temperature

-20 °C to +60 °C (-4 °F to +140 °F)

Storage and transport humidity

20% to 90% (no condensation allowed)

Storage and transport pressure

700 hPa to 1,060 hPa

Dimensions Approx. 280 × 125 × 398 mm (w/h/d)
(11 1/8 × 5 × 15 3/4 inches) (excluding
the projection parts)

Mass Approx. 9 kg (19 lb 13 oz)

Printing system

Sublimation heat transfer printing

Printable pixels

When printing the full-image: 2528 ×
1920 dots

Total gradation 256 levels each for yellow, magenta,
and cyan

Printing time When the printer is set to high speed:
Approximately 20 seconds

Thermal head 14.93 dots/mm

TV system Selectable with the dip switch for
NTSC/PAL selection
In NTSC mode: NTSC/480i
In PAL mode: PAL/575i

Input connectors

RGB/Component (BNC × 3):

0.7 Vp-p

SYNC ON G

SYNC (BNC × 1)

0.3 to 4 Vp-p, sync negative

S VIDEO (4-pin mini-DIN × 1):

Y: 1 Vp-p, sync negative

C: 0.286 Vp-p (NTSC), 0.3 Vp-p
(PAL)

VIDEO (BNC × 1) :

1 Vp-p, sync negative

AC IN (for power input)

Miscellaneous

Output connectors

RGB/Component (BNC × 3):

0.7 Vp-p

SYNC ON G: ON/OFF

SYNC (BNC × 1)

1.0±0.2, sync negative

S VIDEO (4-pin mini-DIN × 1):

Y: 1 Vp-p, sync negative

C: 0.286 Vp-p (NTSC), 0.3 Vp-p (PAL)

VIDEO (BNC × 1):

1 Vp-p, sync negative

Controls connectors

REMOTE 1: special mini jack ×1

For RM-5500 Remote Control Unit (not supplied)

REMOTE 2 (automatic printing connector): Stereo mini jack: × 1

For RM-91 Remote Control Unit (not supplied) or FS-24 Foot Switch (not supplied) (See “Assigning Functions to the Remote Control Unit” on page 60.)

RS-232C (Computer control interface):

D-SUB 25-pin connector ×1

Output: 5-kilohm load

Typical ± 8 V

Input: 5-kilohm load

High level 5 to 15 V

Low level -5 to -15 V

USB host port for the USB flash memory device

Built-in clock Accurate within 180 seconds per month

Supplied accessories

Paper tray (1)

Ink ribbon holder (1)

Before Using this Printer (1)

Instructions for Use (1)

CD-ROM (1)

Service Contact List (1)

Optional accessories

UPC-55 Color Printing Pack

Medical Specifications

Protection against electric shock:

Class I

Protection against harmful ingress of water:

Ordinary

Degree of safety in the presence of a flammable anesthetic mixture with air or with oxygen or nitrous oxide: Not suitable for use in the presence of a flammable anesthetic mixture with air or with oxygen or nitrous oxide

Mode of operation:

Continuous

Using the automatic printing capabilities (REMOTE 2)

If you send remote control pulse signals as illustrated through the REMOTE 2 connector, the printer can be remotely controlled according to the remote control setting. (See “Assigning Functions to the Remote Control Unit” on page 60.)

CAPTURE timing pulse for REMOTE 2:

REMOTE 2 connector pin assignment:

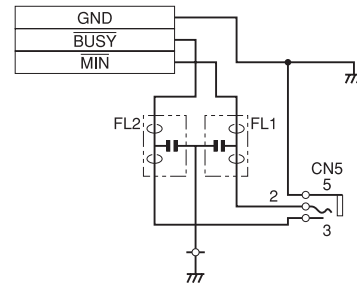
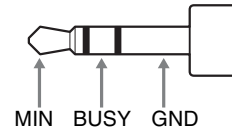

Design and specifications are subject to change without notice.



Miscellaneous

Error/Warning Messages

There are two kinds of messages: error messages and warning messages. This section lists these messages together with their possible causes and remedies. Note the messages and act accordingly.

Error Messages

If a problem occurs, the ALARM lamp lights in orange and an error message stating the problem appears on the monitor and in the printer window display.

In the error message introduced in the following tables, “nn” indicates the number or symbol displayed in the actual message.

Error message		Possible causes and remedies
On the video monitor	On the printer window display	
SET RIBBON	SET RIBBON	There is no ink ribbon loaded. →Load the ink ribbon and paper. (See pages 14 and 17.)
SET PAPER RIBBON REMAIN nn	SET PAPER RIBBON REMAIN nn	<ul style="list-style-type: none"> Paper has been exhausted. →Load the paper. (See page 17.) Also, replace the ink ribbon. There is no paper tray loaded. →Install the paper tray. (See page 17.)
SET RIBBON AND PAPER	SET RIBBON SET PAPER	There are neither ink ribbon nor paper are loaded. →Load the ink ribbon and paper. (See pages 14 and 17.)
REMOVE PRINTS	REMOVE PRINTS	The maximum number of printouts has accumulated on the paper tray. →Remove the printouts. Printing starts again.
REMOVE PAPER TRAY	REMOVE PAPER TRAY	The paper jams around the paper tray. →Remove the paper tray and pull out any jammed paper. (See page 70.)
RIBBON END	RIBBON END	The ink ribbon has been exhausted. →Replace the old one with a new ink ribbon. (See page 14.) (The ink ribbon cannot be reused.) In this case, if the white paper is ejected. Discard this paper.
CLOSE FRONT DOOR	CLOSE FRONT DOOR	The front door is open. →Close the front door.
CHECK RIBBON	CHECK RIBBON	An ink ribbon that can not be used with this printer has been loaded. →Load the appropriate ink ribbon. (See page 65.)
CHECK RIBBON nn	CHECK RIBBON nn	<ul style="list-style-type: none"> The ink ribbon has torn. →Repair the torn ink ribbon. (See page 17.) →When this message appears even though the ink ribbon is not torn, contact your Sony service facility or your Sony dealer to clear the error status.
CHECK PAPER:LOAD nn	CHECK PAPER nn LOAD	Paper has jammed inside the printer. →Remove any jammed paper from the printer. (See page 70.)
CHECK PAPER: EJECT nn	CHECK PAPER nn EJECT	
MECHA TROUBLE:HEAD nn	MECHA TROUBLE nn HEAD	Some trouble occurs in the printer. →Turn off the printer once. Then turn on the printer again and try to operate the printer.
MECHA TROUBLE: PROCESS nn	MECHA TROUBLE nn PROCESS	If the error message appears again, contact your Sony service facility or your Sony dealer to clear the error status.
MECHA TROUBLE: SENSOR nn	MECHA TROUBLE nn SENSOR	
NO MEMORY STICK	NO MEMORY STICK	There is no Memory Stick inserted. →Insert the Memory Stick.

Error message		Possible causes and remedies
On the video monitor	On the printer window display	
Read error in the Memory Stick.	MEMORY STICK READ ERROR	A problem has occurred with the "Memory Stick". → Remove the "Memory Stick" and then insert it again. If the message appears again, contact your Sony service facility or your Sony dealer to clear the error status.
Write error in the Memory Stick	MEMORY STICK WRITE ERROR	
USB MEMORY IS FULL SET NEW STORAGE	USB MEMORY FULL SET NEW STORAGE	The USB flash memory is full. → Use another USB memory flash, or delete unnecessary files from the USB memory flash using a computer.
The USB Memory File Name End	USB MEMORY FILE NAME END	→ When IMAGE COPY on the FUNCTION SETUP menu is set to CYC, these message do not appear and files are deleted in sequence, starting with the oldest.
USB MEMORY ERROR	USB MEMORY ERROR	A problem has occurred with the USB flash memory device.
Write error in the USB Memory. Set USB Memory again.	USB MEMORY WRITE ERROR	→ A USB flash memory device which the printer does not support was used. Use a USB flash memory device manufactured by Sony Corporation. → Remove the USB flash memory device and then insert it again.

Warning Messages

In case of a warning, only warning messages appear. The ALARM lamp does not light.

Warning message		Possible causes and remedies
On the video monitor	On the printer window display	
HIT ANY KEY	HIT ANY KEY	This message appears when the remote control unit is used in CAP-STOP (CAPTURE STOP) mode and when the printer stops capturing images once images have been captured to all memory pages (to the last point of the last memory page). → Press any button. Printer operation is enabled after this.
INPUT MISMATCH	INPUT MISMATCH	<ul style="list-style-type: none"> The TV system of the signal input from the source equipment (VTR, video camera and so on) is not compatible with the TV system of your printer. → Check the signal of the TV system and input the correct one. → Check the setting of the NTSC/PAL selector on the rear panel. (See page 12) A signal other than a video signal (such as an audio signal, etc.) is input. → Input the correct video signal.
NO INPUT	NO INPUT	<ul style="list-style-type: none"> The printer is not receiving an input signal from equipment corresponding to the input selected on the INPUT SETUP menu. → Check the input signal selected on the INPUT SETUP menu. (See page 19.) → Check whether the video equipment is outputting a video signal in playback mode. → Check that the connections between the signal source equipment and the printer are secure. (See page 12.)
NO IMAGE	NO IMAGE	The image is not captured in memory. → Capture the image in memory then start printing. (See page 22.)
PLEASE WAIT PRINTING MEMORY	PLEASE WAIT PRINTING MEMORY	In the selected memory page, the captured image is being printed or queued. → Retry the operation once the printer finishes printing.
PLEASE WAIT ADJUSTING HEAD TEMP	PLEASE WAIT ADJUSTING TEMP	The temperature of the thermal head is being adjusted. → Leave the printer until this message disappears. The printer starts printing automatically.

Troubleshooting

If Damage is Suspected

The following troubleshooting checks will help you correct the most common problems you may encounter with your unit. Before proceeding with these trouble checks, first check that the power cord is firmly connected. Should the problem persist after you have applied the remedy, unplug the unit and contact your Sony dealer or local authorized Sony service facility.

Symptoms	Possible causes and remedies
Nothing appears on the video monitor even if you press any of the operation buttons.	<ul style="list-style-type: none"> The POWER switch of the printer is not set to ON. →Set the POWER switch of the printer to ON. The POWER switch of the video monitor is not set to ON. →Set the POWER switch of the monitor to ON. Connections may not be correct. →Check connections and rectify, if necessary. (See page 13.)
No message appears on the regular screen.	An incorrect signal is input. →Select another input signal on the INPUT SETUP menu. (See page 19.) Or, set the connected video equipment to playback mode, if it is currently set to another modes such as stop mode.
No message or image appears on the regular screen.	<ul style="list-style-type: none"> If an image captured in memory appears when the SOURCE/MEMORY button is pressed, SOURCE on the OUTPUT SETUP menu is set to THRU. →Change the SOURCE setting to EE. (See page 53.) When the menu is displayed by pressing the MENU button, the DISPLAY setting of the video monitor is set to OFF. →Set the DISPLAY setting to ON by pressing the DISPLAY button. (See page 43.)
No message appears on the printer window display.	The contrast of the printer display window is not set correctly. →Adjust the brightness of the printer window display using the LCD-CNTR. item on the SYSTEM SETUP menu. (See page 62.)

Symptoms	Possible causes and remedies
The printer does not print.	<ul style="list-style-type: none"> An error message appears on the display. →Perform the steps described in “Error/Warning Messages” on page 67. Paper that cannot be used with this printer has been loaded. →Load the correct paper. Use only ink ribbons and paper for this printer. (See page 65.) The paper is not loaded correctly. →Check which side of the paper is the printing side, then load the paper again. (See page 17.)
A black line appears on the printout.	Any portion for which there is no signal is printed in black. →Adjust the image area to be printed. (See page 56.) Then, capture a new image and print it.
The printed image is partially cut out.	Only part of the video signal has been stored. →Adjust the image area to be printed. (See page 56.) Then, capture a new image and print it.
The printout is blurred.	A quickly moving image has been stored. →Set the memory mode to FIELD by using the MEMORY FAME/FIELD item on the LAYOUT SETUP menu, then print it. (See page 30.)
The printout color is very pale.	The paper is not loaded correctly. →Check which side of the paper is the printing side, then load the paper again. (See page 17.)
The blank paper is ejected even if you press the PRINT button and RIBBON END message appears.	The ink ribbon has been exhausted. Do not reuse the ejected blank paper. →Replace the ink ribbon. (See page 14.)

If the Paper Jams

If paper jamming has occurred after the PRINT button has been pressed, the message “SAVING IMAGES...” appears and all of the images captured in the printer and all of the menu settings are stored. When this message disappears, remove the jammed paper as follows.

Note

Be sure not to turn the power off while the message “SAVING IMAGES...” is displayed. Doing so results in image data that is not stored correctly.

- 1 Push in the paper tray to remove it.
If any printouts have been ejected onto the paper tray and have accumulated on the paper tray, remove them before removing the paper tray.

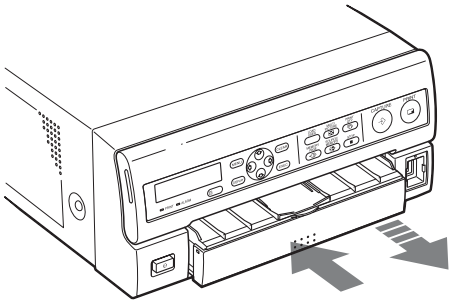

- 2 Check whether any paper is jammed inside the printer. If you find a jammed sheet, slowly pull it straight out.

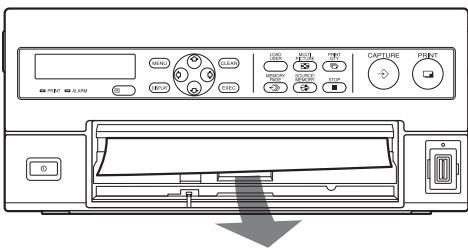

If you cannot remove the jammed paper even if you perform the operation in step 2, remove the jammed paper according to instructions described in the following “If you can not remove the jammed paper yet”.

- 3 Load the paper into the paper tray correctly.

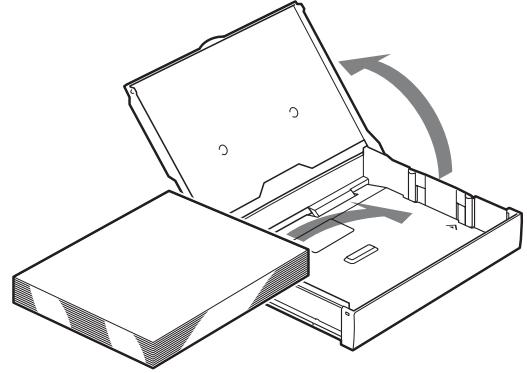

Notes

- Do not reuse the jammed paper. Discard that paper.
- Use only paper recommended in this manual.

- 4 Re-insert the removed paper tray.

If you can not remove the jammed paper yet
Proceed as follows to remove the jammed paper.

Precautions

- Turn the printer power off and remove the AC power cord from the printer.
 - When you turn the printer over, remove any connecting cables. If cables are broken or bent, this may cause fire or electrical shock.
 - When you remove the jammed paper, be careful not to injure your fingers when touching the parts inside the printer.
- 1 Be sure to set the power switch of the printer to off and remove the AC power cord and other connecting cables.
 - 2 Remove the ink ribbon cartridge and the paper tray from the printer.
 - 3 Turn the printer over.

- 4** Remove the one screw with which the back cover plate is secured, using a coin.

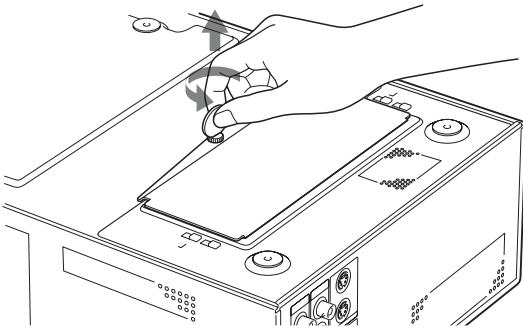

- 5** Pull the back cover plate up and remove it from the printer.

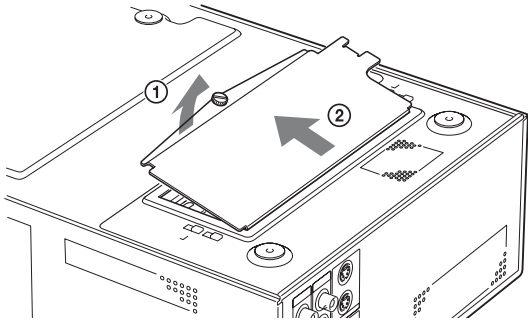

- 6** Remove the jammed paper slowly.

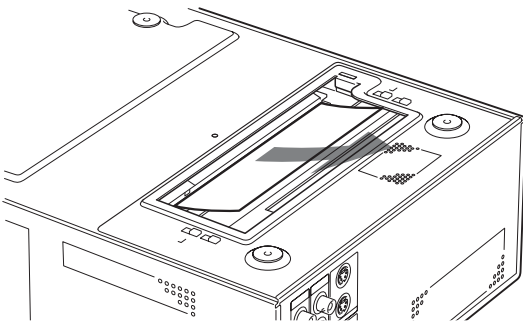

If you still cannot remove the paper

Do not try to remove it forcibly. Contact your nearest Sony dealer.

- 7** Replace the back cover plate.

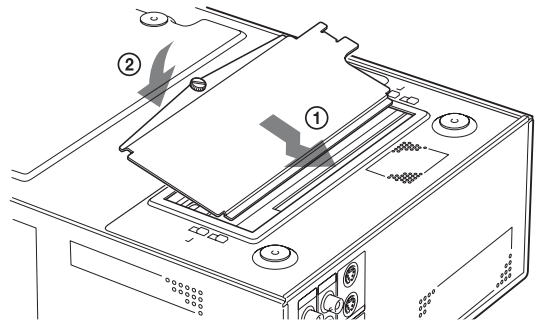

Note

When you put the back cover plate on, be careful not to catch your fingers or any other object.

- 8** Secure the back cover plate using the screw removed in step 4.

Confirm that the screw holes of the back side of the printer and the back cover plate match before securing them.

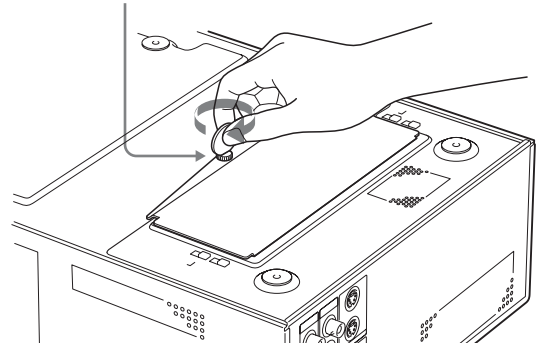

When using the printer again

Confirm the following before using the printer again.

- Confirm that any connecting cables and the AC power cord are securely connected.
- Reset the paper tray in the printer.
- When the power is turned on, a message appears. Use the printer following the instructions given in the message. For details, see the following.

To turn on the power

When you turn on the power for first time after you have turned off the power with the message “SAVING IMAGES” displayed, proceed as follows.

- 1** Press the POWER switch.

The following message appears.

RESTORE MEMORY IMAGES? YES/NO

This message appears when you turn on the power for the first time after you have turned off the power with the message “SAVING IMAGES” displayed. This message asks you whether or not image data and all of menu settings stored in the on-board “Memory Stick” are to be loaded into the printer.

- 2 To load image data into the printer memory, select YES.
If you don’t want to load image data in to the printer memory at this time, select NO.
Even if you select NO, you can load the data into the printer memory later.
For detailed information, see “Loading all of the image data and menu settings from the on-board “Memory Stick” into the printer manually” on page 72.
- 3 Press the EXEC button.
When you select YES in step 2: the message “READING IMAGES...” appears, and then another message “RESTORE FINISHED” appears.
The normal screen appears.
When you select NO in step 2: the normal screen appears.

Note

When the message “SAVING IMAGES” appears, all of current menu settings are stored in a on-board “Memory Stick”, in addition to image data. When image data are loaded from the on-board “Memory Stick” into the printer, all of the menu settings are also loaded.

Storing all of the image data and menu settings currently set in the printer in the on-board “Memory Stick” manually

- 1 Display FUNCTION SETUP menu from the PRINTER SETUP menu.
- 2 Select STORE IMAGE by pressing the ⬆ or ⬇ button.
- 3 Select STORE by pressing the ⬅ or ➡ button.
- 4 Press the EXEC button.
The message “SAVING IMAGES...” appears.
When this message disappears, the normal screen appears. Go to the next operation.

Note

In this case, image data and menu settings stored in the “Memory Stick” are overwritten.

Loading all of the image data and menu settings from the on-board “Memory Stick” into the printer manually

- 1 Display the FUNCTION SETUP menu from the PRINTER SETUP menu.
- 2 Select STORE IMAGE by pressing the ⬆ or ⬇ button.
- 3 Select RESTORE by pressing the ⬅ or ➡ button.
- 4 Press the EXEC button.
Loading starts and the message “READING IMAGES...” appears. Then another message “RESTORE FINISHED” appears.
When this message disappears, the normal screen appears. Go to the next operation.

Note

When the message “READING IMAGES” appears, all of the current menu settings stored in the on-board “Memory Stick”, in addition to stored image data are loaded from the on-board “Memory Stick”. The image data and menu settings currently set in the printer are overwritten.

Notes on “Memory Stick”

- A “Memory Stick” slot is built in the right side inside the front door. If a “Memory Stick” is not inserted here, the printer cannot save image data or load data. Do not remove the “Memory Stick”.
- The “Memory Stick” is provided to store the image data of the printer. You cannot make printouts of image data stored via a digital camera or computer.
- If you lost a “Memory Stick”, prepare a “Memory Stick” that exceeds 32 MB in capacity.
- The printer does not support “Memory Stick PRO” and “Memory Stick PRO Duo”.

Index

- A**
 - Accessories
 - ink ribbon holder 12
 - paper tray 12
 - Adjusting the color and picture quality
 - adjusting the color balance 57
 - adjusting the printout color 53
 - compensating for the input signals 52
 - eliminating the black lines
 - produced on printouts 56
 - matching the video monitor color to the printer color 52
- B**
 - Blur
 - eliminating the blur 22
- C**
 - Caption
 - CAPTION menu 36
 - entering 37
 - Cleaning
 - cabinet 64
 - COLOR ADJUST menu 54
 - COLOR BALANCE menu 57
 - Connections
 - connecting the video monitor 13
 - connecting video equipment 12
 - for enabling remote control 14
- D**
 - Deleting the images stored in memory pages
 - deleting a certain reduced image 42
 - deleting all images stored in the memory 41
 - deleting images in a certain memory page 42
 - setting the function of the CLEAR button 41
 - Display
 - erasing the screen display on the video monitor 43
 - type and remaining amount of the ink ribbon 62
- E**
 - Eliminating the blur 22
- Error messages 67
- F**
 - Full-size image printout
 - making 22
 - setting 31
 - FUNCTION SETUP menu 33, 41, 60
- I**
 - Ink ribbon
 - handling 17
 - notes on storing 17
 - Ink ribbon cartridge
 - if you cannot remove 15
 - loading 14
 - removing 15
 - INPUT SETUP menu 19, 52
 - Input signal 19
 - Introduction 8
- L**
 - LAYOUT SETUP menu 30, 32, 40, 46
 - LOAD COLOR number
 - recalling 55
 - selecting 54
 - storing 55
 - Location and function of parts and controls
 - front panel 8
 - monitor display 10
 - rear panel 10
- M**
 - Memory mode
 - field mode 29
 - frame mode 29
 - selecting 30
 - Memory page
 - about the memory page 30
 - selecting 31
 - “Memory Stick”
 - loading all of the image data and menu settings 72
 - notes 72
 - storing all of the image data and menu settings 72
 - Menu
 - basic menu operation 49
 - CAPTION menu 36
 - COLOR ADJUST menu 54
 - COLOR BALANCE menu 57
 - FUNCTION SETUP menu 33, 41, 60
 - INPUT SETUP menu 19, 52
 - LAYOUT SETUP menu 20, 30, 32
 - menu tree 48
 - OUTPUT SETUP menu 13, 53, 62
 - PRINTER SETUP menu 25, 26, 33, 56
 - sub menus 51
 - SYSTEM SETUP menu 52, 62, 63
 - WINDOW SETUP menu 56
- Menu tree 48
- Messages
 - error messages 67
 - warning messages 68
- O**
 - Operation 22
 - OUTPUT SETUP menu 13, 53, 62
- P**
 - Paper
 - notes on storing 18
 - Paper jams 70
 - Paper tray
 - inserting 18
 - Precaution
 - before transporting the printer 64
 - condensation 64
 - installation 64
 - safety 64
 - Preparation 12
 - PRINTER SETUP menu 25, 26, 33, 56
 - Printing
 - capturing another image while printing 28
 - fitting the printout to the paper 57
 - if a black line appears on the printout 24, 56
 - if the captured image is blurred 22
 - if the color quality of the printouts is not satisfactory 24
 - if the paper runs out during printing 27
 - if the printer does not print 24
 - if the printout is blurred 35
 - making a printout with multiple reduced images 34
 - making a printout with white borders 35
 - making full-size image printouts 22
 - making multiple copies of identical printouts 26
 - making printouts at high speed 24

making printouts with a caption 36
making printouts with a date 40
making printouts with file names 46
making printouts with the desired user set number 24
selecting the printout type 31
Printing pack
adjusting the color balance 57
available printing pack 65
Printout quality
adjusting the printout color 53
compensating for the input signal 52
eliminating the blur 22
Printout quantity setting 26
Printouts
note on storing 24
variations 29

R

Remote control
using the automatic printing capabilities 66
Remote control unit
using as a wired unit 14
using as a wireless unit 14

S

Setting up the printer on the menu
adjusting the brightness of the printer window display 62
assigning the function to the remote control unit 60
displaying the remaining amount of the ink ribbon 62
functions that can be set on menu 47
selecting whether the operation tone and error tones sound 62
setting the baud rate for the computer communication 62
Specification 65
System overview 8
SYSTEM SETUP menu 52, 62, 63

T

Troubleshooting 69

U

USB flash memory device
file name 44
removing 44
storing image data 44

when becoming full 45
User set
recalling 24, 63
registering 62

W

Warning messages 68
WINDOW SETUP menu 56

