



# KAYAT PTF-28

WRAP AROUND TRAY/CASE PACKERS

F&T

FLEXIBLES  
& TRAYS

# Kayat PTF-28

## WRAP AROUND TRAY/CASE PACKERS

### Kayat PTF-28 Wrap Around Tray/Case Packers

The Kayat PTF-28 is an intermittent motion wrap around tray/case packer for the beverage, food, and non-food industries.

The Kayat PTF-28 is designed to handle a wide range of products, it packs up to 30 cases per minute, depending on the application.

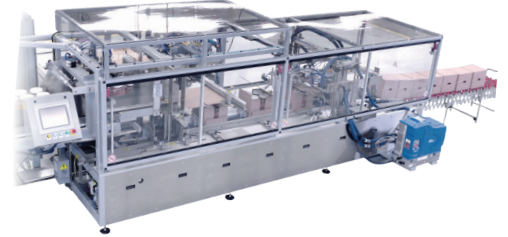

*The Kayat PTF-28 wrap around case/tray packer is a stand-alone machine that can be integrated into new production lines or added to existing lines.*

#### PRODUCT APPLICATIONS

- Beverages in plastic or glass bottles, cans and jugs
- Canned food
- Household and personal care in bottles, cans, jars and jugs



#### FEATURES & BENEFITS

- Ability to handle a wide variety of products and case sizes
- Heavy-duty rugged construction
- Long-wear contact parts
- Interlocked guarding
- Cluster block lubrication system
- Low pressure infeed section
- Fallen container detection

#### OPTIONS

- Spare parts kit
- Servo driven lift and cycle chain indexing
- Transfer conveyor
- Adhesive phenolic tags
- Individual guard door enunciation
- Lane divider
- Printer integration
- Top plexi-glass cover for top frame portion of the machine
- Special elevation parts
- NEMA 4X control panel, junction boxes
- Siemens controls

## CONFIGURATION

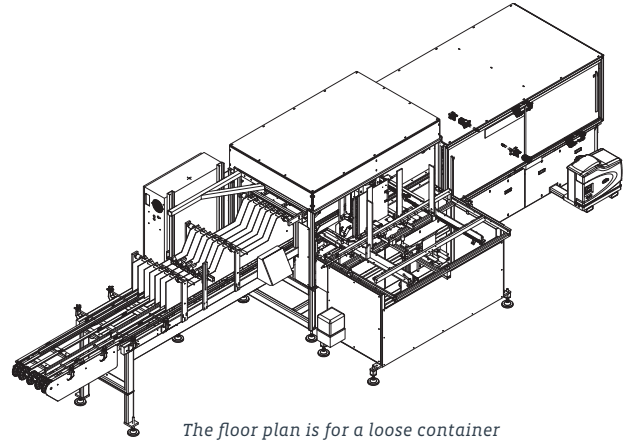
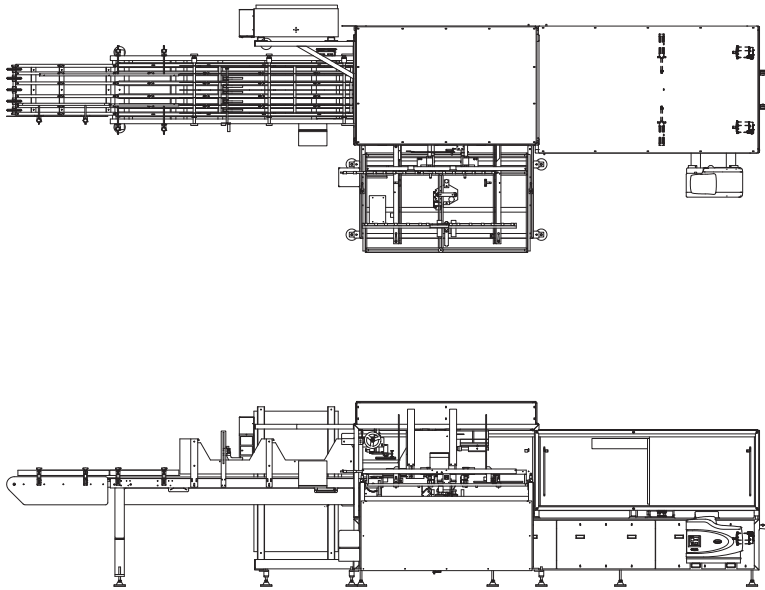

*The floor plan is for a loose container option with the 45" extension.*

Contact Bartelt to inquire about packaging machinery to fit your unique requirements.

(941) 359-4000

### AIR/ELECTRICAL SPECIFICATIONS

<b>Power</b>	460V, 60Hz, 3-phase Controls: 24VDC
<b>Control Panel</b>	Standard - Rockwell electric design

<b>Pressure</b>	80 PSI / 5.5 Bar
<b>Flow</b>	5 SCFM

### MACHINE DIMENSIONS

<b>Width</b>	103" (2,619 mm)
<b>Length</b>	283" (7,188 mm)

<b>Conveyor Height</b>	Infeed: 45" (1,143 mm) Discharge: 24" (609 mm)
------------------------	---

### PACK SIZES (WIDTH X LENGTH X HEIGHT)

<b>Minimum</b>	7" x 6.5" x 1.75" (178 mm x 165 mm x 44 mm)
----------------	---

<b>Maximum</b>	21" x 20" x 13" (533 mm x 508 mm x 330 mm)
----------------	--



Bartelt is a trusted manufacturer of pouching, cartoning, shrink wrapping, over wrapping, and case and tray packing systems, providing dependable and long-lasting solutions to food and non-food industries. Bartelt also operates as the master distributor for FLtècnics' rollstock and pre-made pouch machines. As the world's first developer of intermittent motion horizontal form fill seal pouching machines, Bartelt is a true pioneer in automated packaging. From simple to advanced applications spanning primary and secondary packaging, quality components and a durable design are incorporated into every solution.

Bartelt is a product brand of ProMach, a global leader in packaging line solutions. As part of the ProMach Flexibles & Trays business line, Bartelt helps our packaging customers protect their products and earn the trust of their consumers.

ProMach is performance, and the proof is in every package. Learn more about Bartelt at [www.BarteltPackaging.com](http://www.BarteltPackaging.com) and more about ProMach at [www.ProMachBuilt.com](http://www.ProMachBuilt.com)

BARTELT PACKAGING, LLC  
5501 N. Washington Blvd.  
Sarasota, FL 34243

P: 941-359-4000  
E: [Bartelt.Sales@ProMachBuilt.com](mailto:Bartelt.Sales@ProMachBuilt.com)  
[BarteltPackaging.com](http://BarteltPackaging.com)