

JAN. 1992

**PRESS BRAKE  
FBD1025, 1030 NC9EX**

**PARTS LIST**



1992/1/30

# CONTENTS (1)

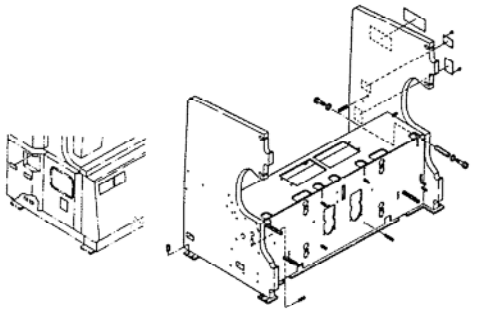
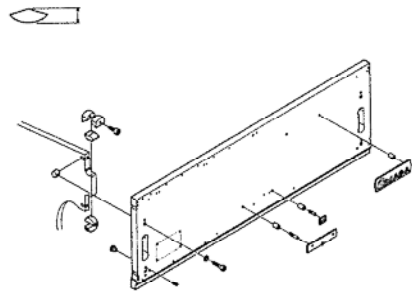
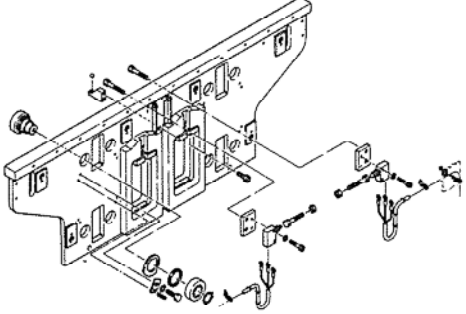
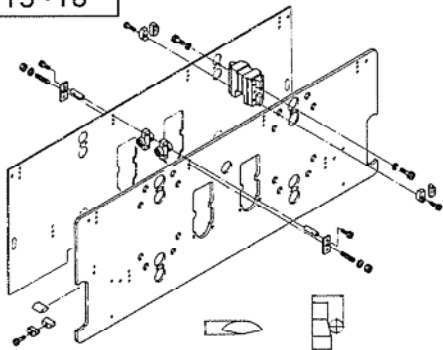
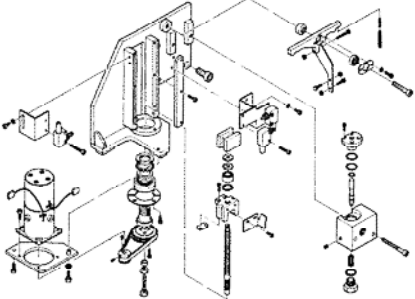
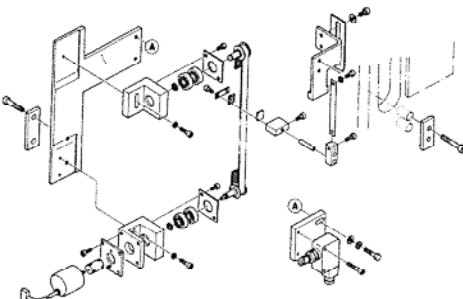
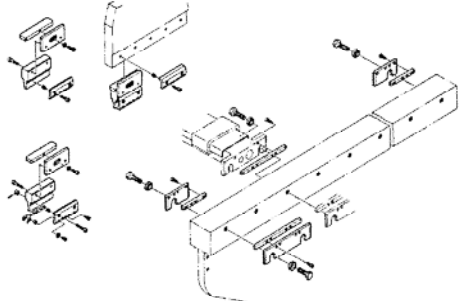
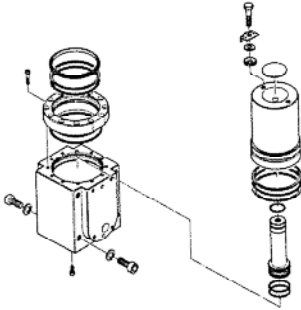
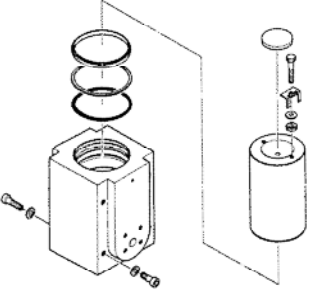
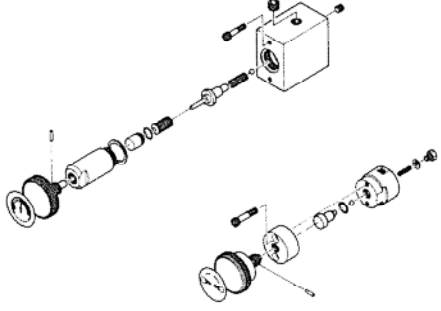
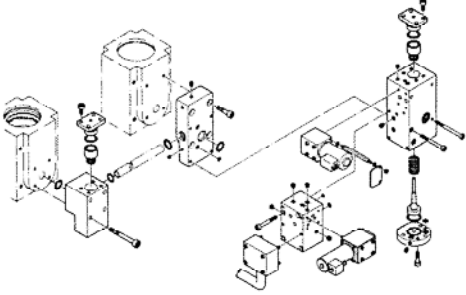
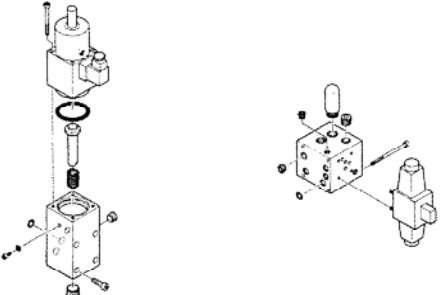
01   Frame	02   Upper beam	03   Lower beam	04   Support plate
1~6	7~10	11~14	15~18
			
05   Upper limit setting device	06   Lower limit setting device	07   Tool holder	08   Main cylinder
19~28	29~36	37~42	43~46
			
09   Sub cylinder	10   Cut-off, Regulator valve	11   Check valve	12   Solenoid, Unload valve
47~48	49~52	53~60	61~64
			

# CONTENTS (2)

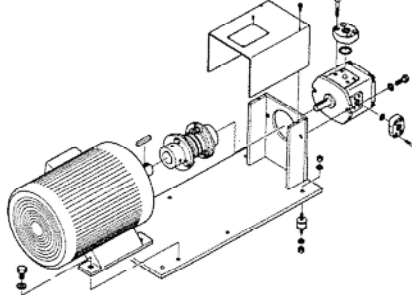
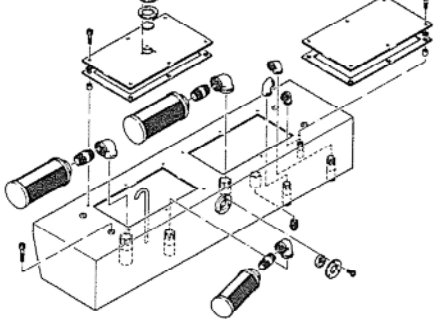
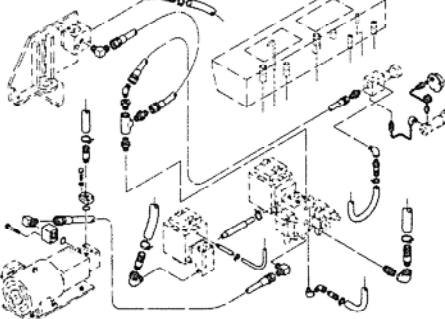
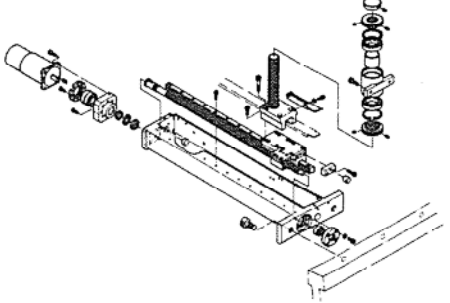
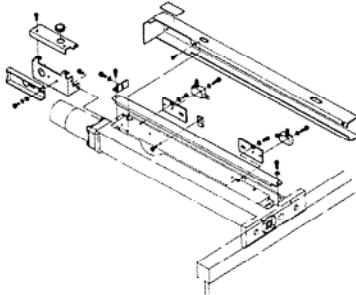
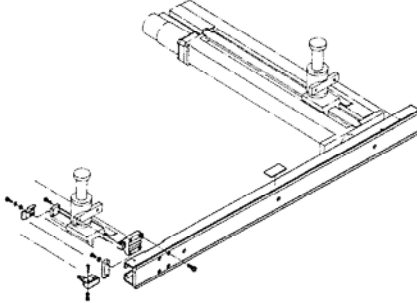
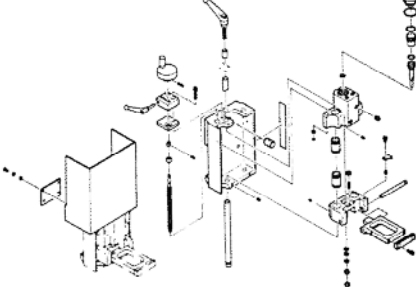
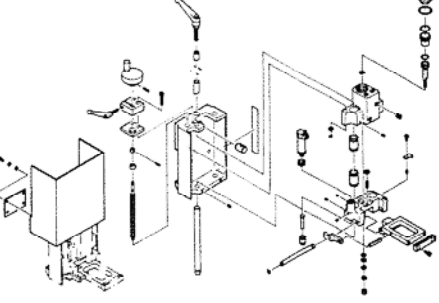
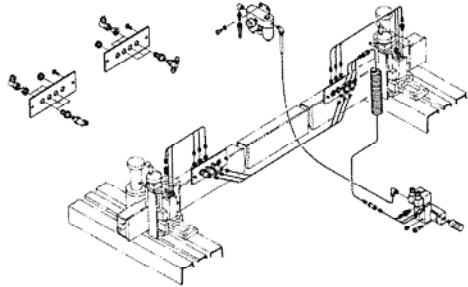
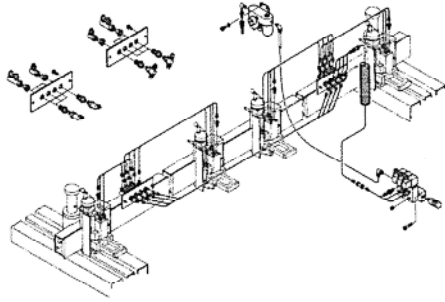
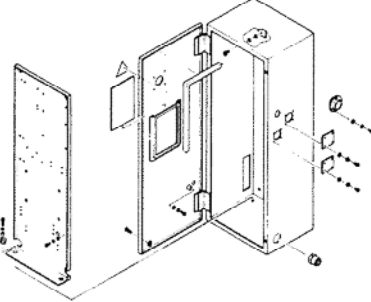
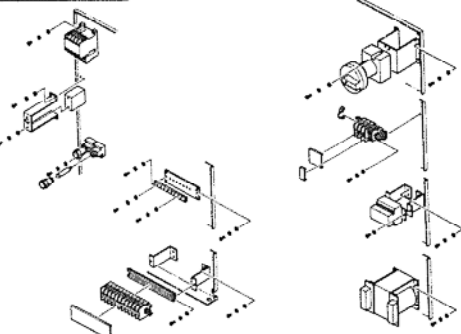
<b>13</b> Hydraulic pump	<b>14</b> Hydraulic tank	<b>15</b> Hydraulic piping	<b>16</b> Support (1)
65~66	67~70	71~78	79~84
			
<b>17</b> Support (2)	<b>18</b> Stretch	<b>19</b> Work stopper	<b>20</b> Flip-up work stopper – EUR
85~88	89~92	93~100	101~108
			
<b>21</b> Pneumatic piping (1) – USA	<b>22</b> Pneumatic piping (2) – EUR	<b>23</b> Electric (1) – EUR	<b>24</b> Electric (2) – EUR
109~114	115~120	121~126	127~132
			

# CONTENTS (3)

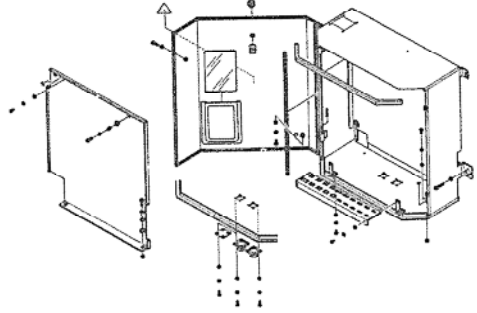
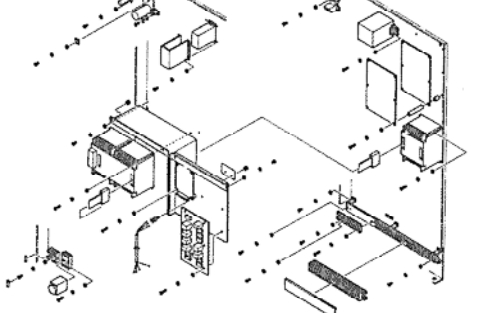
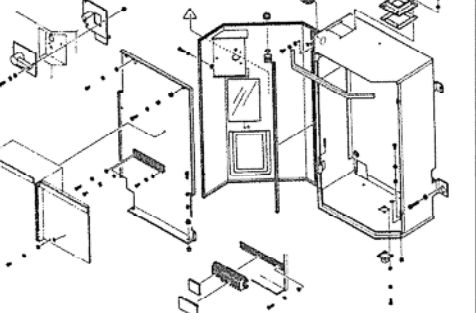
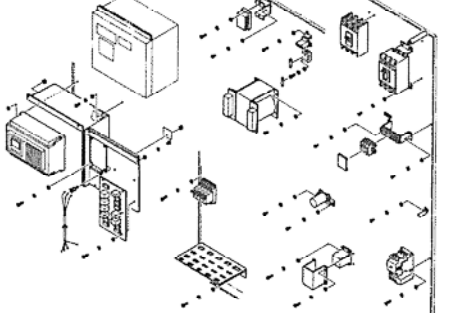
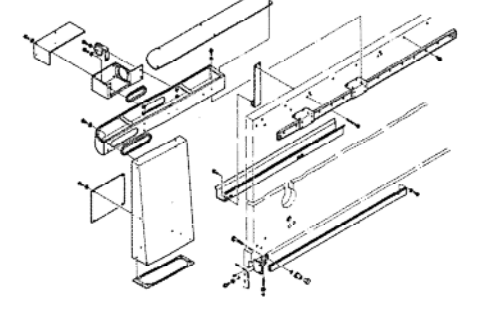
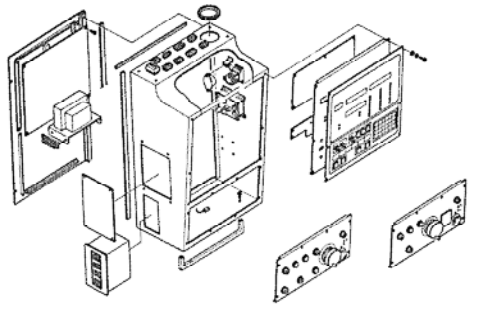
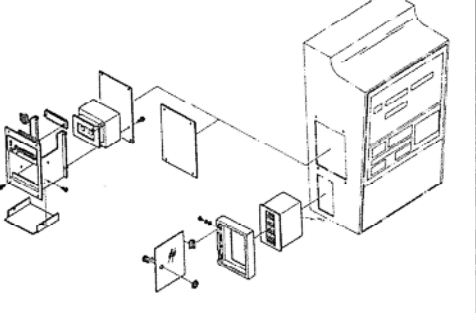
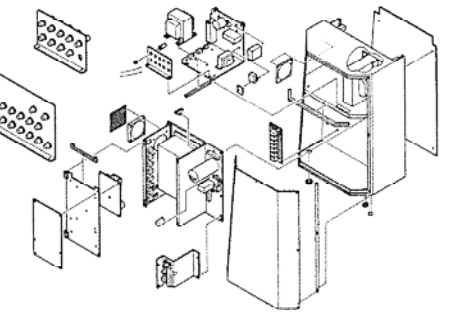
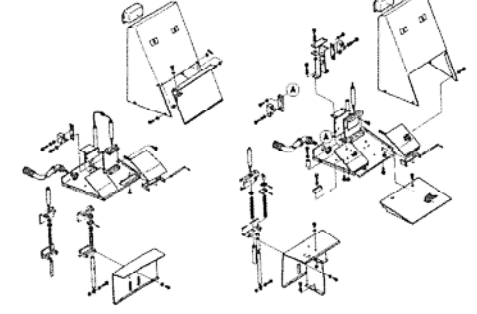
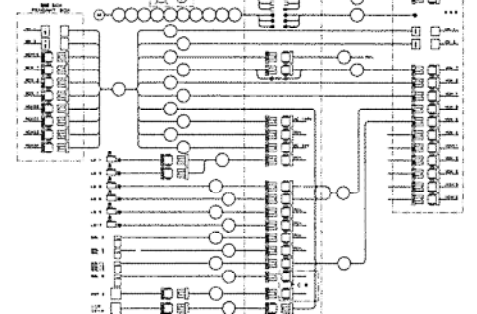
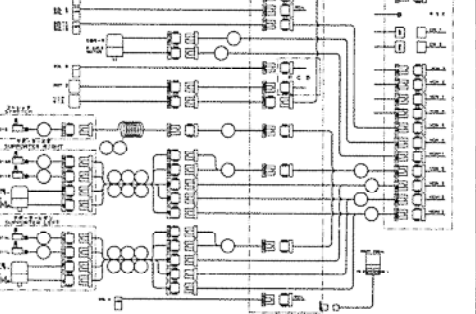
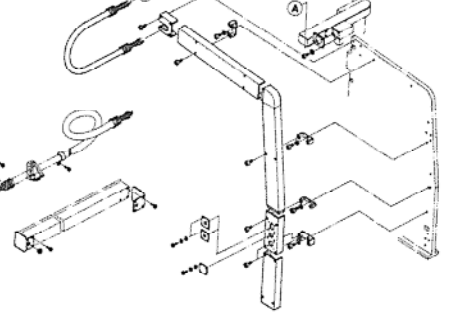
<b>25</b> Electric (3) – EUR	<b>26</b> Electric (4) – EUR	<b>27</b> Electric (5) – USA	<b>28</b> Electric (6) – USA
133~138	139~146	147~152	153~162
			
<b>29</b> Rail – 8025	<b>30</b> Operation box (1)	<b>31</b> Operation box (2)	<b>32</b> Control box
163~170	171~178	179~182	183~192
			
<b>33</b> Foot pedal	<b>34</b> Electric wiring (1)	<b>35</b> Electric wiring (2)	<b>36</b> Electric wiring (3)
193~204	205~212	213~222	223~228
			

# CONTENTS (4)

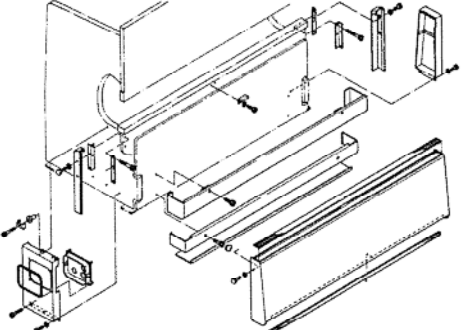
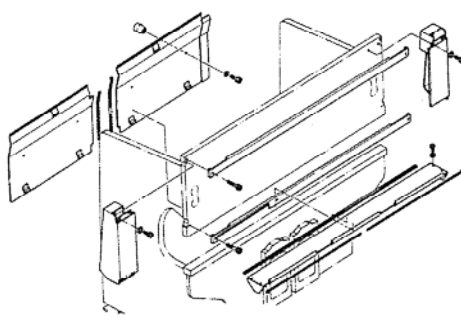
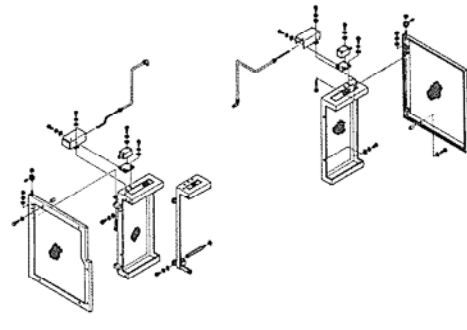
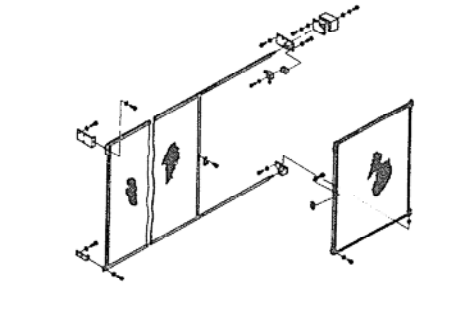
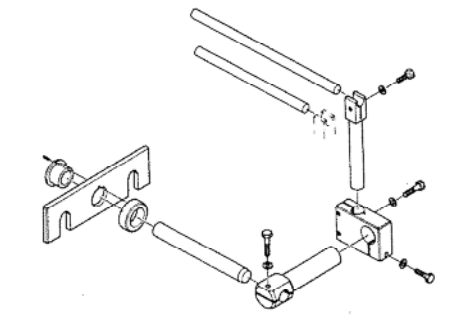
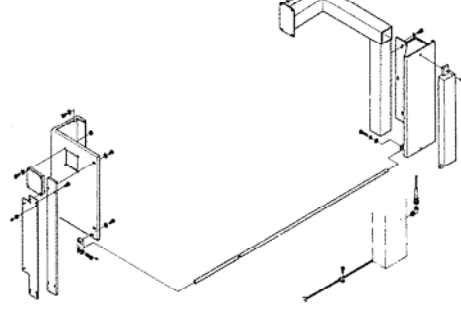
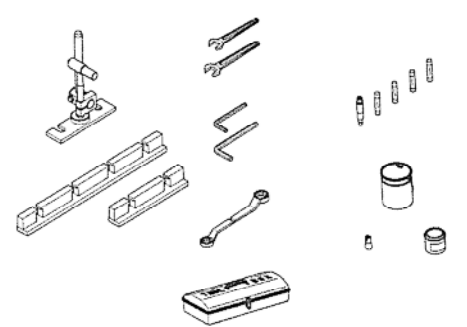
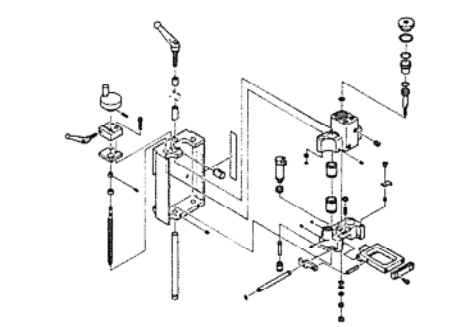
<b>37</b> Cover (1)	<b>38</b> Cover (2)	<b>39</b> Side guard – EUR	<b>40</b> Rear guard – EUR
229~234	235~240	241~246	247~252
			
<b>41</b> Front support – EUR	<b>42</b> Photo-electric safety device – UK	<b>43</b> Standard accessories	<b>44</b> Flip-up work stopper – USA
253~256	257~262	263~264	265~272
			
<b>45</b> Pneumatic piping (3) – USA			
273~278			
