

KOLBUS → Perfect binding

RATIOBINDER

Ratiobinder KM 470

6,000 cycles/h

ZU 804

Gathering machine ZU 804

6,000 cycles/h

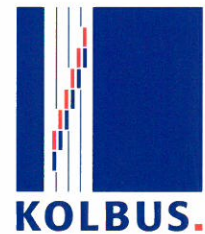

Ratiobinder KM 470

Economic

Professional

Proven in practice

Ratiobinder **KM 470**

→ For the low-cost introduction into high quality perfect binding

→ For economic perfect binding production

Utilize the many **KOLBUS** advantages for your success

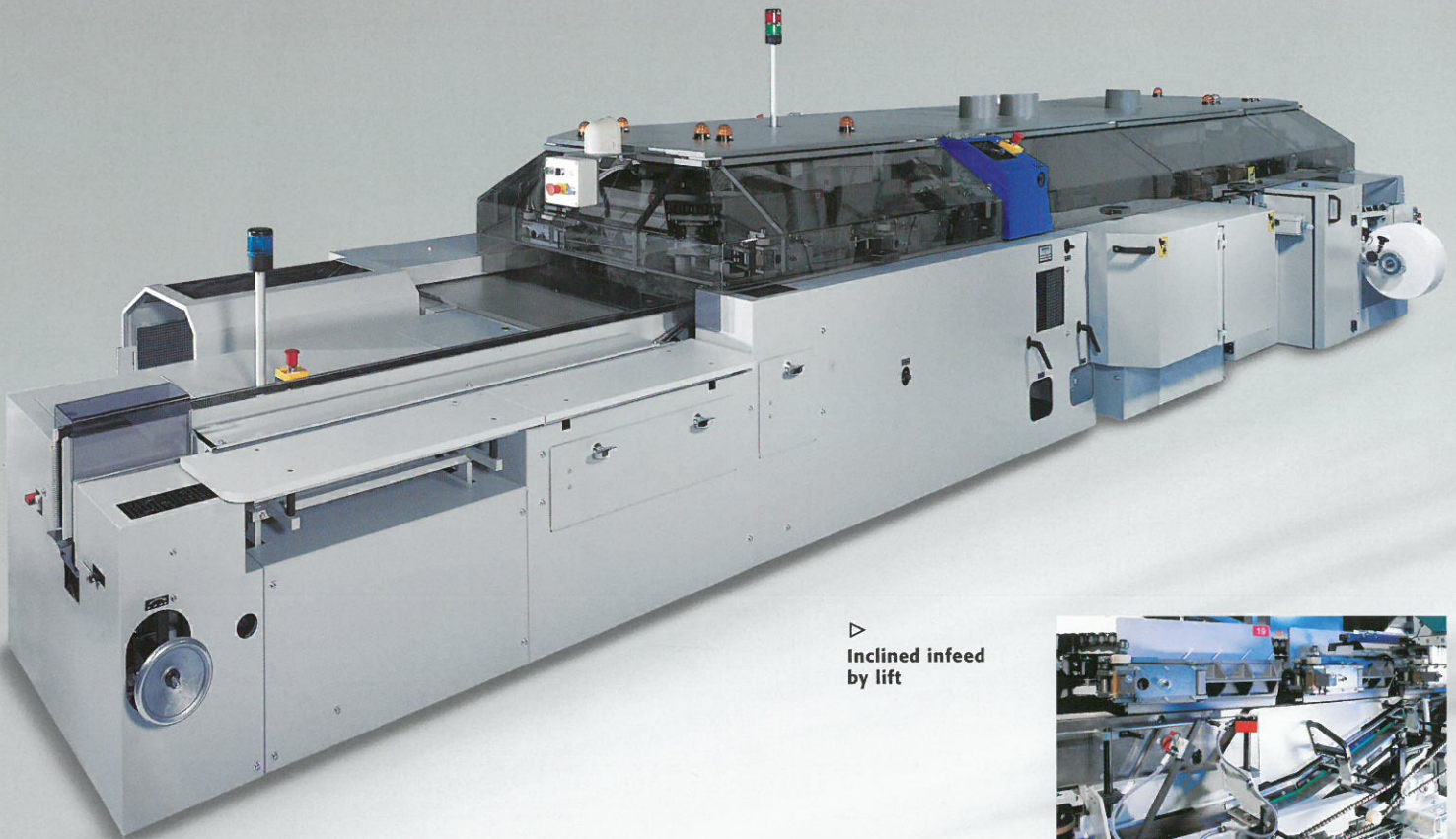

▷
Inclined infeed
by lift



▷
Cover station –
here with stream
cover feeder



KOLBUS assists your entry into perfect binding with a manageable investment: The KM 470 is economic, easy to operate and proven in practice as a result of more than 400 machine lines sold world wide.

This 21 clamp perfect binder developed for the medium performance range is rated at 6,000 cycles/h, and, mechanically, is almost identical to the more powerful KM 472.A. It operates without the **KOLBUS** Copilot system as an economic alternative.

The equipment versions are extensive. All types of brochures, even layflat products can be produced. In addition, the Ratiobinder enables the production of thread-sewn or thread-sealed book blocks. The Ratiobinder is a proven all-purpose machine used in daily practice.

Quality features of this highly practical binder are, amongst others, the inclined infeed by lift (patented) as well as the sturdy clamp system which is also patented. Up to three spine processing stations prepare the block for gluing. Hotmelt, dispersion and PUR glues can be used depending on the requirement profile of the product.

Optional equipment includes also a lining station. Either a rotary or a stream cover feeder are available.

The best processing quality is guaranteed by the highly effective pressing stations in conjunction with accurate cover aligning. The most difficult cover materials can be processed without a problem.

The KM 470 can also be equipped with an HF dryer and a subsequent second pressing station. The production of layflat products is possible using special equipment.

- 1 Manual feeding station with jogging unit
- 2 Infeed with jogging unit
- 3 Carriage lift
- 4 Precentering of the joint
- 5 Spine processing stations
- 6 Gluing stations
- 7 Lining station
- 8 Intermediate heating zone
- 9 Cover station
 - Feeder
 - Scoring station
- 10 Cover aligning and pressing station
- 11 2nd pressing station
- 12 Gripper carriage delivery

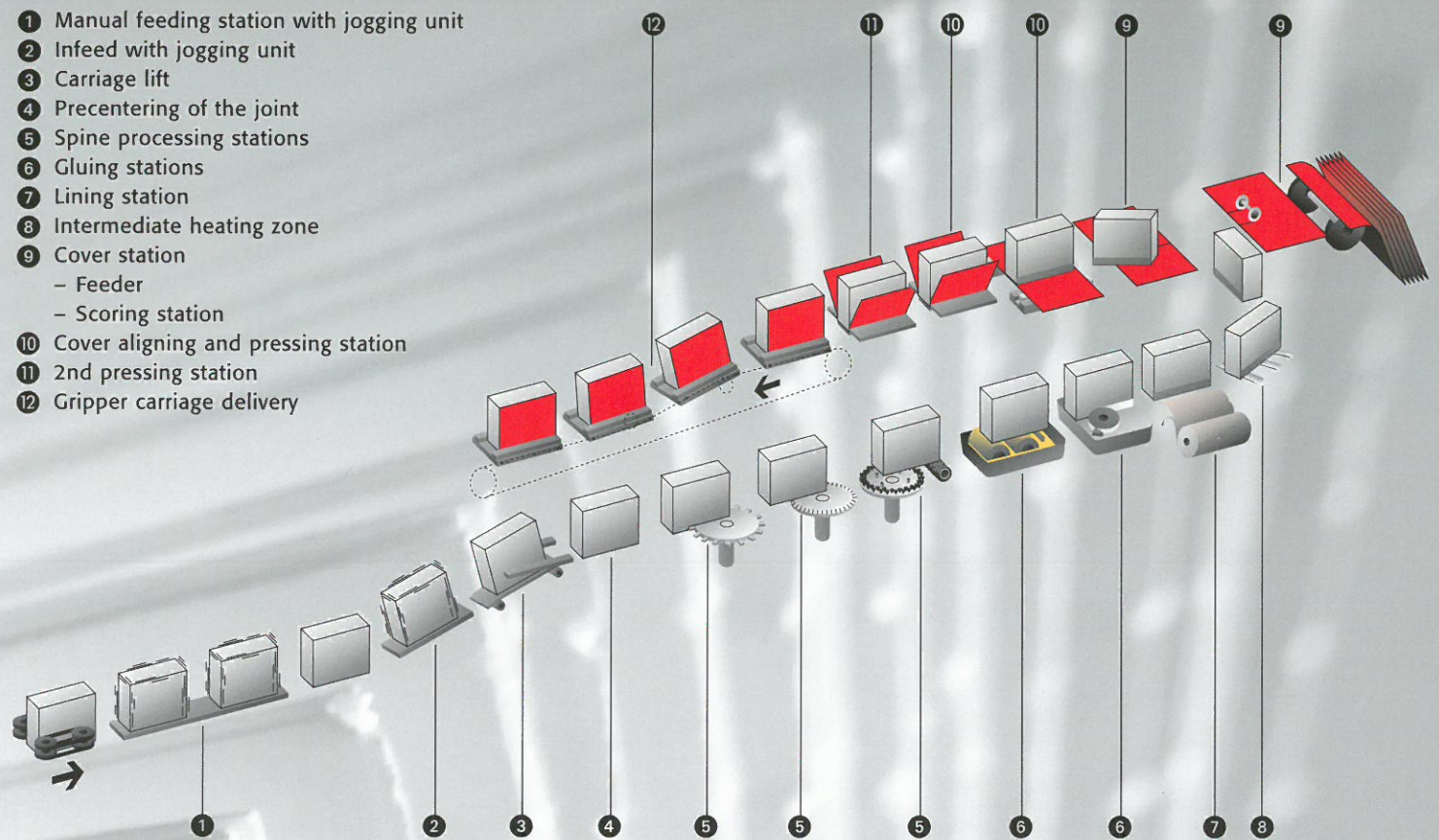

△ Rotary cover feeder

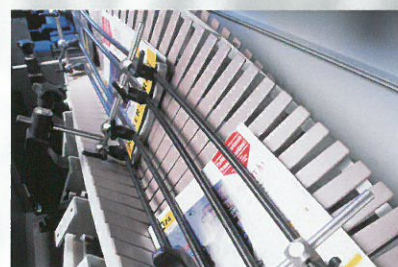
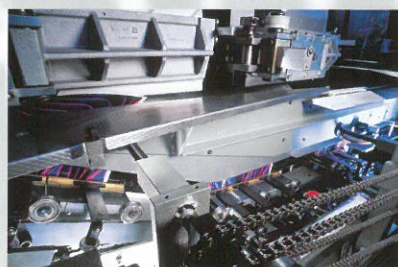

△△ Gripper carriage delivery

△ Lay-down device

The products leave the binder either in the patented **KOLBUS** gripper carriage delivery or on a belt delivery. They are then transferred to a stack delivery or a lay-down device (plate chain) for ongoing transport.



▷ Spine processing stations



▷ Gluing stations

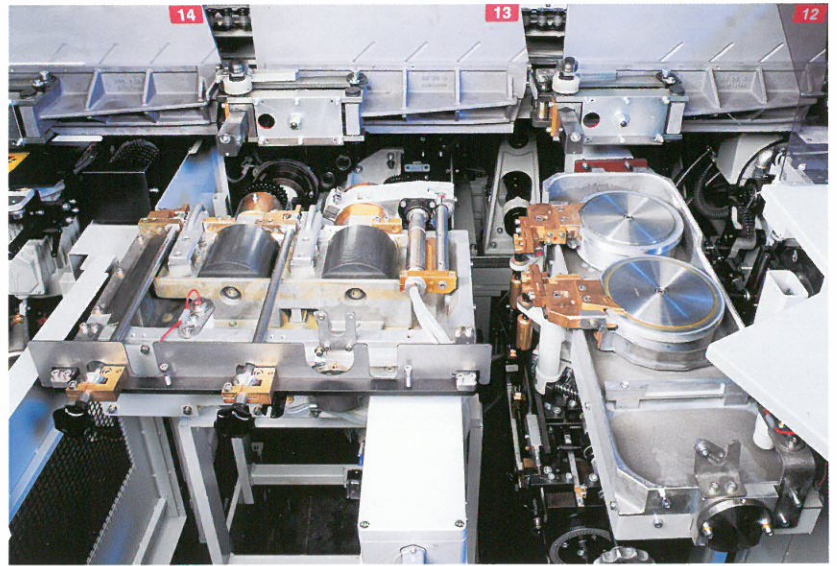

△ Pressing station

Example for the inline production of perfect bound brochures

- ① KOLBUS Gathering machine ZU 804
- ② KOLBUS Ratiobinder KM 470
- ③ KOLBUS Three knife trimmer HD 150.B
- ④ Compensating stacker

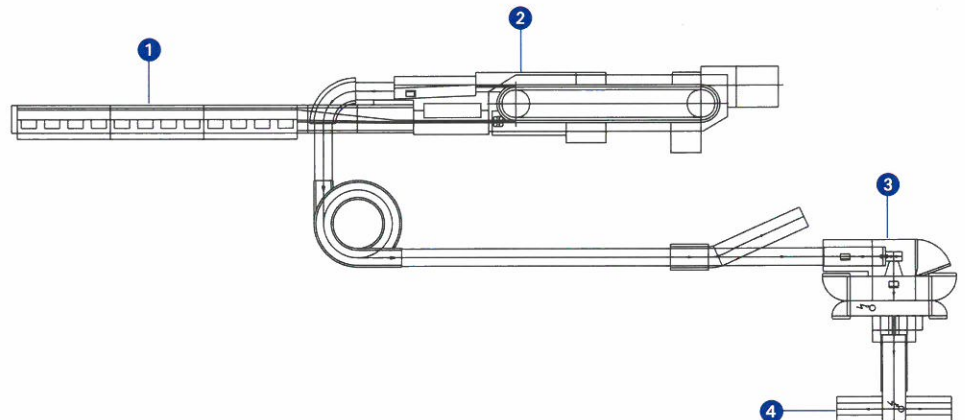

Gathering machine **ZU 804**

KOLBUS offers the ZU 804 as the gathering machine suitable for the Ratiobinder KM 470.

State of the art control technology and intelligent monitoring systems ensure smooth production. The ZU 804 is equipped with the opto-electronic section detection system and ATC automatic section thickness control.

In addition to automatic loading and unloading of the machine, the cascade control also enables a reject discharge to be used.

Separation is performed using the drum principle. All operating elements are easily accessible in the gantry frame.

Choose the professionals for whom discussing and offering customers the best tailored solution is the top priority.



△
**Gathering machine
ZU 804**



△
**Section detection
system SC**

KOLBUS GmbH & Co. KG
Osnabrücker Straße 77
D-32369 Rahden
Tel. +49 (0) 5771 · 71-0
Fax +49 (0) 5771 · 71333
www.kolbus.com

