

SBT Series Technical Details

SBT Series	Cutting Length	Cutting Capacity		Throat Depth	Stroke per min.	Cutting Angle	Holddowns	Holddown Force	Back Gauge Range	Back Gauge Force
		MS (450 N/mm ²)	SS (700 N/mm ²)							
	inch	inch	inch	inch	1/min.	°	lbf	inch	kW	
	A			D						
3006	122	0,25	0,15	2	15	1° 30'	16	31500	39	0,75
3010	122	0,40	0,25	2	13	1° 30'	16	5000	1000	0,75
3013	122	0,50	0,30	2	13	1° 45'	16	83200	1000	0,75
3016	122	0,60	0,40	14	10	2°	14	137200	1000	0,75
3020	122	0,80	0,50	14	6	2°	14	173200	1000	0,75
4006	161	0,25	0,15	2	12	1° 30'	20	38500	1000	0,75
4013	161	0,50	0,25	14	8	1° 45'	18	14000	1000	0,75

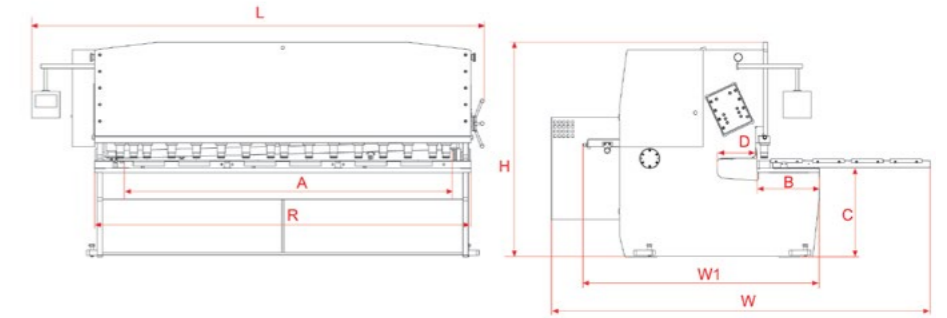

Back Gauge Speed	Motor Power	Oil Capacity	Front Arms	Tabla Height	Table Width	Table Length	Length	Width	Total Width	Height	Weight
mm/sec.	kW	gallon	Unit	inch	inch	inch	inch	inch	inch	inch	~pound
				C	B	R	L	W1	W	H	
8	15	53	2	34,1	19,7	138,4	161,8	86,6	145,7	82,7	16000
8	22	53	2	34,1	22,8	138,4	165,4	88,6	141,7	82,7	20000
8	30	87	2	33,3	23,6	139,8	168,5	90,6	141,7	92,5	26000
8	37	108	2	32,2	21,7	140,9	179,1	88,6	150,6	88,6	32000
8	45	120	2	34,9	22,4	144,5	175,2	89,0	133,9	96,5	45500
8	15	53	3	34,1	22,8	177,6	205,9	90,6	141,7	84,6	25500
8	30	87	3	32,2	21,7	178,0	210,6	88,6	151,6	88,6	36000

Standard & Optional Equipment

Standard Equipment

- Heavy duty St 44 steel construction & stress relieved frame
- User friendly CNC Touch screen control unit D-Touch 7
- Easy blade gap adjustment
- Ball integrated front tables
- Ballscrew back gauge, 1000 mm & automatic swing-up
- Squaring arm with scale & T-Slot & tilting stop
- Support arms T-Slot & Tilting stop
- Illumination & shadow line 1 mt flip-up finger guards
- Automatically pressure adjusted solid holddowns
- Top blades with 2 sides and Bottom blades with 4 sides
- Foot pedal
- High performance hydraulics & electronics components
- Automatic Swing-up back gauge
- CE-Norm

Optional equipment

- Motorized blade gap adjustment
- Laser cutting line
- Light curtains for finger protection
- Pneumatic thin sheet support DURMA I
- Pneumatic thin sheet support DURMA IV
- Special throat depth
- Backgauge 1250 mm.
- Add. support arms
- Special blades
- Oil coolant
- Oil Heater
- Adjustable angle stop 0-180°
- Control panel on opposite position
- Temperature measurement
- Overseas special packaging