

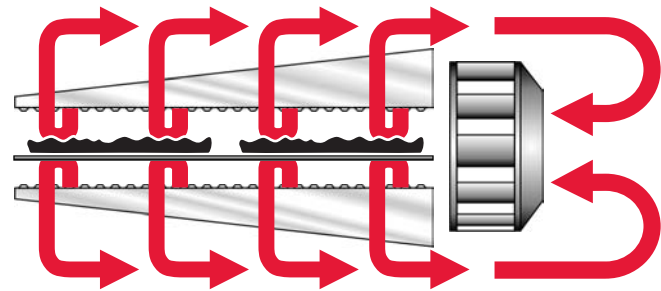

Principle

Middleby Marshall PS Series conveyor ovens bake both faster and at a lower temperature than other ovens. Vertical columns of hot air move heat aerodynamically instead of using high temperatures. The streams of hot air remove the boundary layers of cool heavy air which tend to insulate the product. All Middleby ovens are designed to cook a multitude of products including pizza, seafood, sandwiches, bagels, ethnic foods and more.



General Information

The PS536ES conveyor oven is ideally suited for Kiosk and express-style locations where smaller ovens are required.

Standard Features

- **Impingement PLUS!** low oven profile and dual air return
- **Patented EMS Energy Management System*** reduces energy consumption and increases cooking efficiency
- 36"/914mm long cooking chamber
- 18"/457mm-wide, 60"/1524mm long conveyor belt
- Stackable up to three units high
- Patented "Jet Sweep" impingement process that delivers constant heat to the chamber
- Microprocessor-controlled bake time/conveyor speed
- Customer-specific adjustable jet fingers that allow control of heating zones in 8"/203mm zones
- Stainless steel front, sides, top and interior
- Front-loading window with cool handle
- Reversible conveyor direction
- Stainless steel lower shelf (single and double ovens)

Optional Features

- Split belt - two 9"/229mm belts with individually adjustable speed settings
- High speed conveyor (Range of 1:00 - 10:00)
- 76"/1930mm-long conveyor
- Stainless steel lower shelf (triple ovens)

Conserves Energy

Unit incorporates a patented Energy Management System - EMS. Middleby ovens provide very efficient heat transfer to product. Energy is conserved as air is recycled from heater to product, with minimum loss. Oven is cool to the touch.

Cleanability

PS536ES Ovens are designed for easy cleaning. Removable parts include: crumb pans, end panels, air fingers, exit tray, and a removable conveyor belt assembly.

Easily Services

Control compartment is designed for quick and easy access.

Warranty

All PS536ES models have a one year parts and labor warranty. Oven start-up is included at no additional charge (USA only).

Ventilation

Use of a ventilation hood is strongly recommended.



Form 4803E Rev 1 11/08



1401 Toastmaster Drive
Elgin, IL 60120 USA
(847) 741-3300 Fax: (847) 741-0015
www.middleby.com

NOTE: Height dimensions are shown for standard leg extensions. Customer-specific leg extensions will affect these dimensions.

NOTE: All units are shown with casters. CE-approved ovens use 6"/152mm adjustable feet instead of casters.

PS536ES-1

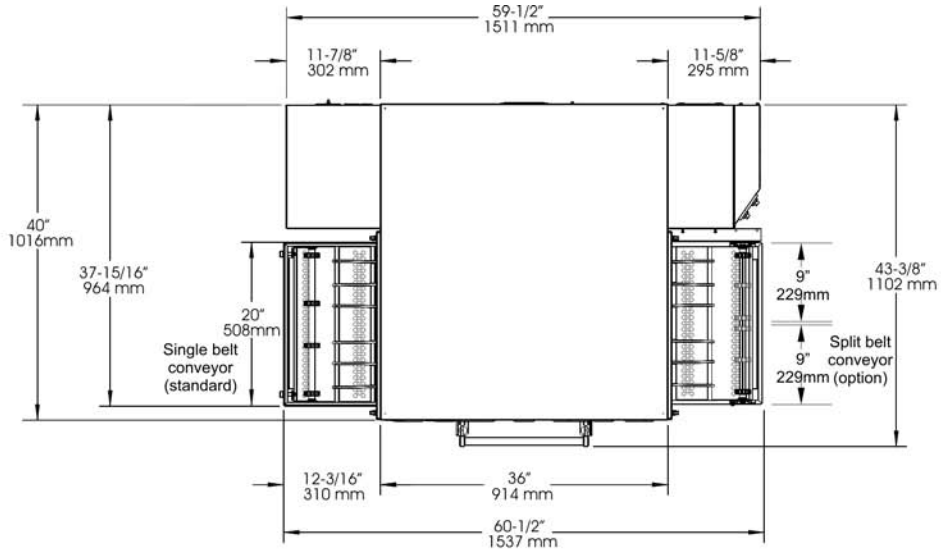

TOP VIEW

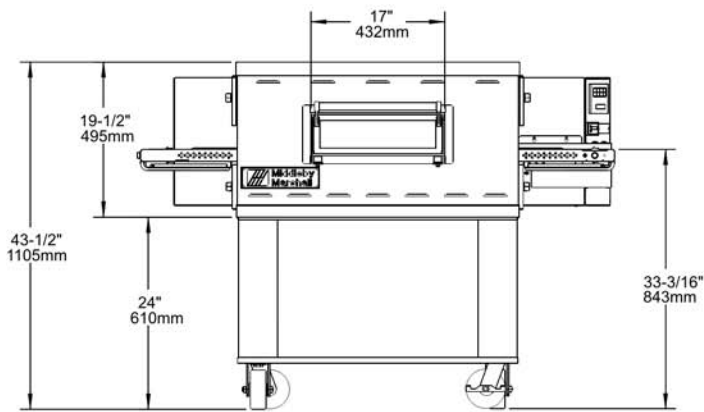

FRONT VIEW

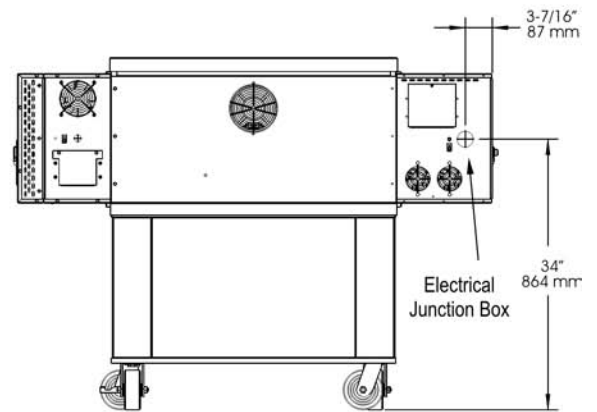

BACK VIEW

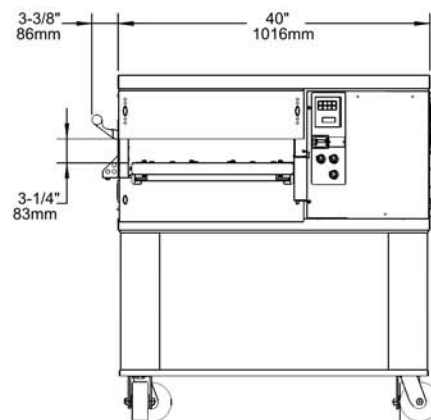

SIDE VIEW

NOTE: Height dimensions are shown for standard leg extensions. Customer-specific leg extensions will affect these dimensions.

NOTE: All units are shown with casters. CE-approved ovens use 6"/152mm adjustable feet instead of casters.

PS536ES-2

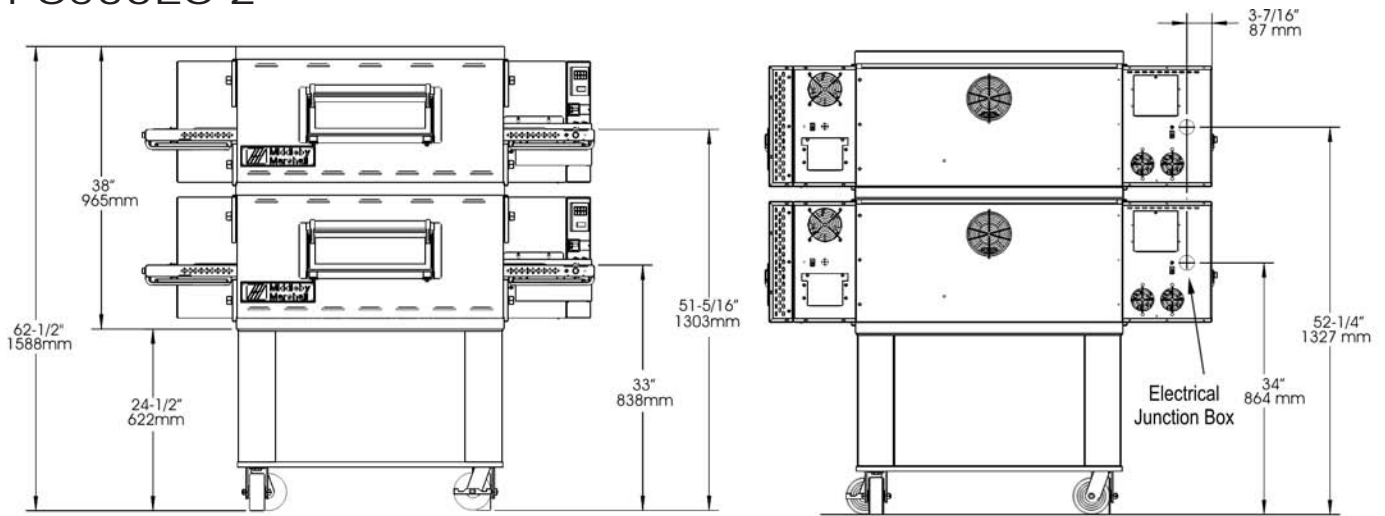

FRONT VIEW

BACK VIEW

PS536ES-3

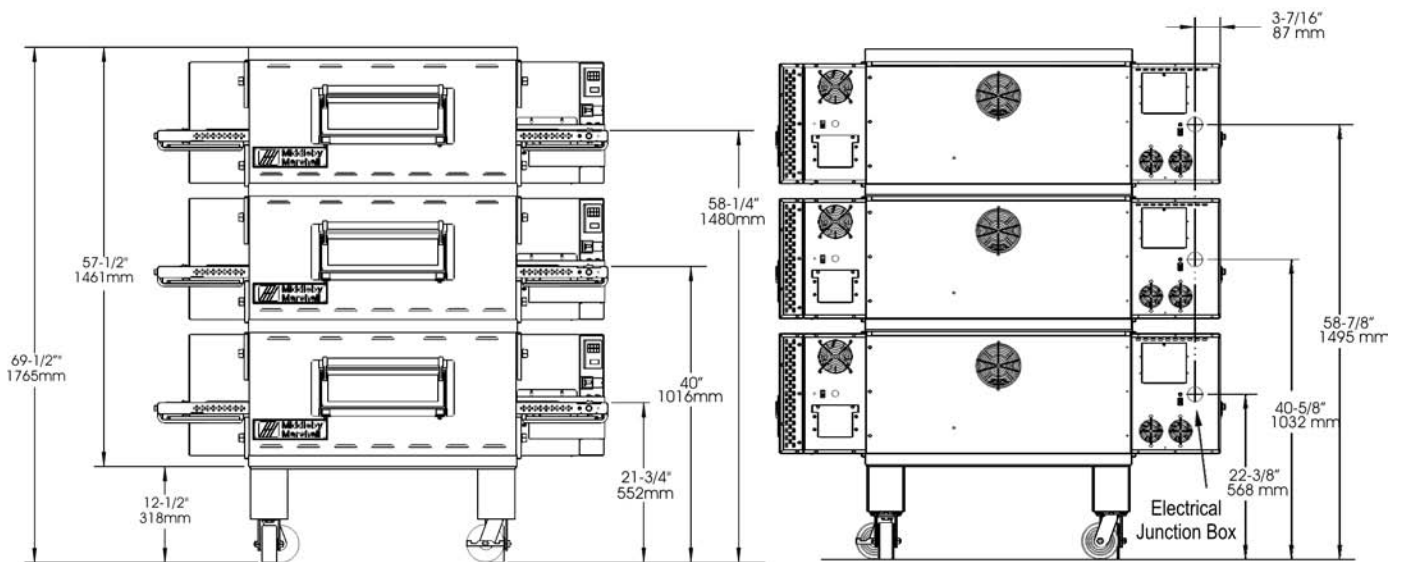

FRONT VIEW

BACK VIEW









RECOMMENDED MINIMUM CLEARANCES

Rear of Oven to Wall	Control end of conveyor to wall	Non-control end of conveyor to wall
3" (76mm)	1" (25.4mm)	1" (25.4mm)

GENERAL SPECIFICATIONS

	Heating Zone	Baking Area	Belt Length	Belt Width	Overall Length (exit trays installed)	Height	Depth	Maximum Operating Temp	Bake Time Range	Ship Wt	Ship Cube
PS536-1 with 17.5" (446mm) leg extensions	36" 914mm	5 ft ² 0.465 m ²	60" 1524mm or 76" 1930mm	18" 457mm or 2x9" 229mm	60" 1524mm or 76" 1930mm	43-1/2" * 1105mm	43-3/8" 1102mm	550°F 288°C	3-30 min or 1-10 min	699lbs 317kg	75.1ft ³ 2.13m ³
PS536-2 with 17.5" (446mm) leg extensions	72" 1828mm	10 ft ² 0.930m ²	60" 1524mm or 76" 1930mm	18" 457mm or 2x9" 229mm	60" 1524mm or 76" 1930mm	62-1/2" * 1588mm	43-3/8" 1102mm	550°F 288°C	3-30 min or 1-10 min	1398 lbs 634 kg	150.2 ft ³ 4.25m ³
PS536-3 with 6" (152mm) leg extensions	108" 2743mm	15 ft ² 1.395 m ²	60" 1524mm or 76" 1930mm	18" 457mm or 2x9" 229mm	60" 1524mm or 76" 1930mm	69-1/2" * 1765mm	43-3/8" 1102mm	550°F 288°C	3-30 min or 1-10 min	2097 lbs 951 kg	225.3 ft ³ 6.38m ³

ELECTRICAL SPECIFICATIONS

Version	Voltage	Phase	Freq	Max Amperage*	Rated Heat Input	Supply	Breakers
 	208v	3	50/60 Hz	54A	17.0 kW	3 pole, 4 wire (3 hot, 1 ground)	As per local codes
 	240v	3	50/60 Hz	47A	17.0 kW	3 pole, 4 wire (3 hot, 1 ground)	As per local codes
 	380v 480v	3 3	50/60 Hz 50/60 Hz	32A 27A	17.0 kW 17.0 kW	4 pole, 5 wire (3 hot, 1 neutral 1 ground)	As per local codes
  	380v	3	50/60 Hz	32A	17.0kW	4 pole, 5 wire (3 hot, 1 neutral 1 ground)	As per local codes

* The current draw rating shown above are maximum values for normal operation, amperage draw will be less than the listed value.

ALL SPECIFICATIONS SUBJECT TO CHANGE WITHOUT NOTICE.