

OPERATION, MAINTENANCE MANUAL



Doosan Infracore
Portable Power

G10WMI-2D-T2 (B63)

G25WMI-2A-T2 (B54)

G40WMI-2A-T2 (B50)

G60WJD-2A-T2 (B55)

G70WJD-2A-T3 (D63)

G80

G90WJD-2A-T3 (C24)

G125

G145WJD-2A-T3 (C27)

G185WJD-2A-T3 (C28)

G240WJD-2B-T3 (C31)

G240WCU-2C-T3 (D97)

G290WCU-3B-T3 (C38)

G290WCU-3C-T3 (D77)

G450WCU-2B-T2 (C34)

G450WCU-2C-T2 (D96)

G570WCU-2B-T2 (C37)

G570WCU-2C-T2 (D78)

GENERATOR MODELS



This manual contains important safety information.

Do not destroy this manual.

This manual must be available to the personnel who operate and maintain this machine.

Doosan Infracore Portable Power
1293 Glenway Drive
Statesville, N.C. 28625
www.doosanportablepower.com

Book: 22637300 (8-2-2010) Rev H



TABLE OF CONTENTS
Operation & Maintenance Manual

TITLE	PAGE
DRAWBAR NOTICE	5
SAFETY SYMBOLS	7
SAFETY	13
HAZARDOUS SUBSTANCE PRECAUTION	20
GENERAL DATA	21
Unit Model:	22
Unit Model:	23
Unit Model:	24
Consumables Service Parts:	25
Consumable Service Parts:	26
Expendable Service Parts:	27
OPERATING INSTRUCTIONS	29
BEFORE TOWING	30
TOWING	31
SETTING UP	31
DISCONNECT	31
BEFORE STARTING	32
STARTING (AUTOSTART MODELS)	33
STOPPING (AUTOSTART MODELS)	34
REMOTE STARTING AND STOPPING	34
DIAGNOSTICS/AUTO SHUTDOWN (AUTOSTART MODELS)	35
ENGINE CONTROLS and INSTRUMENTS (AUTOSTART MODELS)	35
CUSTOMER - DIAGNOSTIC GAUGE OPERATION	37
STARTING (KEY START MODELS)	38
STOPPING (KEYSTART MODELS)	40
DIAGNOSTICS and AUTO SHUTDOWN (KEYSTART MODELS)	40
ENGINE CONTROLS and INSTRUMENTS (Keystart Models)	41
GENERATOR SYSTEM	42
MONITOR SWITCHES	42
CIRCUIT BREAKERS - Flip to Reset (if equipped)	43
RECEPTACLES (if equipped)	43
PROTECTION/REGULATION	43
VOLTAGE SELECTION/ADJUSTMENTS G25 thru G185	44
SWITCH POSITION - 120/208V 3 Phase	45
SWITCH POSITION - 277/480V 3 Phase	45
SWITCH POSITION - 120/240 1Phase	46
VOLTAGE SELECTION/ADJUSTMENTS G240 thru G570	47
120/208V 3 Phase	49
277/480V 3 Phase	49
BASIC DIGITAL CONTROLS OPERATION	50

TABLE OF CONTENTS
Operation & Maintenance Manual

TITLE	PAGE
MAINTENANCE	65
General	66
Scheduled Maintenance	66
ADJUSTMENT INSTRUCTIONS and TESTING PROCEDURES	71
ACCESSING COMPARTMENT	71
VOLTAGE REGULATOR ADJUSTMENT	71
OVERCURRENT RELAY ADJUSTMENT (Set Dial on the OCR Relay)	72
POWER BYPASS SWITCH FOR ENGINE ECU SERVICE	73
PACKAGE PREVENTIVE MAINTENANCE SCHEDULE	74
ALTERNATOR INSTALLATION AND MAINTENANCE	75
SAFETY MEASURES	76
INSTALLATION - COMMISSIONING	83
SERVICING-MAINTENANCE	88
TECHNICAL CHARACTERISTICS	94



Drawbar Notice

Drawbar Notice

This machine may have been shipped from the factory with the drawbar positioned upright. To convert from shipping position to towing position, the following tools are required:

Tool Required:
Ratchet, 24mm socket and an 18mm socket to fit ratchet
Torque wrench set to 166 ft-lbs (226 Nm) and 67 ft-lbs. (91 Nm)
24mm socket and an 18mm socket to fit torque wrench
Hardware included: (1) 16mm nut, (2) Washers, (2) Safety Chains
1. Remove hardware box from generator.
2. Open box and remove the bag containing hardware, safety chains and assembly instructions.
3. Using the jack, raise the front of the unit so that the end of the drawbar is approximately 1 inch above the ground.
4. While holding the drawbar, carefully remove the temporary retaining bolt that holds the drawbar to the top of the enclosure (See Fig. 1).
5. Carefully lower drawbar to the Level Position.
6. Install the bolt (that was removed in Step 4) with the washers and nut from the included hardware to secure the end of the drawbar underneath the unit and torque to 166 ft-lbs (226 Nm). Also torque the drawbar pivot bolt to 166 ft-lbs. (226 Nm). See Figure 2).
7. Install safety chains by first removing the longest bolt used to attach the hitch then insert the last link of one chain onto the bolt. Slide one spacer back on the bolt and put the assembly back into the hitch. Slide the other spacer onto the bolt, then the last link of the other safety chain washer. Tighten the nut to 67 ft-lbs (91 Nm).

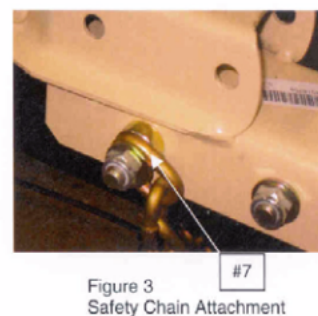
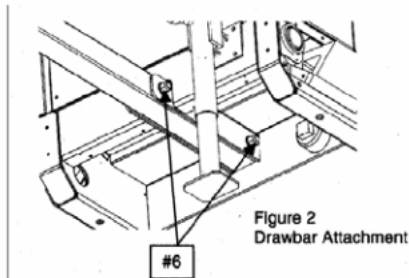
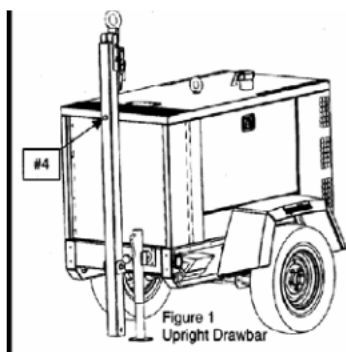







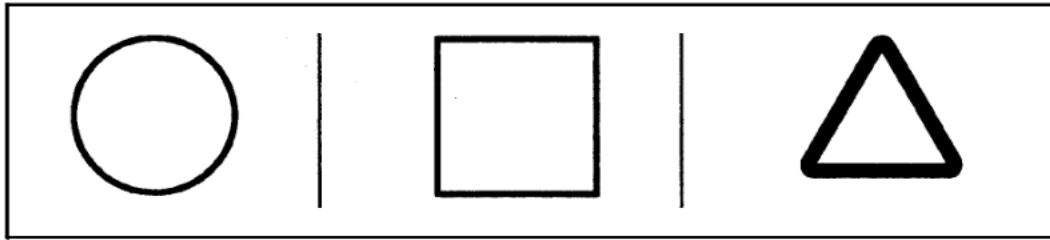

Safety Symbols

Symbols below point out potential safety hazards and provide important information about this machine. Read and understand. Heed warnings and follow instructions. If you do not understand, inform your supervisor.



Prohibition/ Mandatory	Information/Instructions	WARNING
------------------------	--------------------------	---------

<p>WARNING - Read the operator's manual before operating this machine.</p>	<p>WARNING - Do not open radiator until radiator is cool and pressure is relieved.</p>	<p>WARNING - Read the operator's manual before towing machine.</p>

 <p>22688550 REV. A</p>	 <p>22688566 REV. A</p>	 <p>22688564 REV. A</p>
<p>WARNING - Diesel fuel is flammable. No open flames or sparks.</p>	<p>WARNING - Battery contains acid. Gases are flammable. No open flames or sparks.</p>	<p>WARNING - Do not perform maintenance until all electrical power has been disconnected.</p>
 <p> 22688600 REV. A</p>	 <p>22688618 REV. A</p>	
<p>WARNING - Rotating fan.</p>	<p>65 MPH maximum towing speed.</p>	

Safety Symbols

Look for these signs on machines manufactured in North America, which point out potential hazards to the safety of you and others. Read and understand thoroughly. Heed warnings and follow instructions. If you do not understand, inform your supervisor.

Safety Decals area available free of charge.

Safety decals are identified by the decal heading:

DANGER, WARNING or CAUTION

Decal part numbers are on the bottom of each decal and are listed in the parts manual. Help promote product safety! Assure that decals are present on the machines. Replace decals that are not legible.



Always use genuine replacement parts!



Safety

Safety

DANGER

This machine is not designed for operating life-sustaining equipment. It is equipped with a safety shutdown system that will cause the machine to stop operating whenever a shutdown condition is present.

DANGER

Never operate the engine of this machine inside a building without adequate ventilation. Avoid breathing exhaust fumes when working on or near the machine.

WARNING

A battery contains sulfuric acid and can give off gases which are corrosive and potentially explosive. Avoid contact with skin, eyes, and clothing. In case of contact, flush area immediately with water.

WARNING

Improper operation of this equipment can cause severe injury or death. Read Operator's Manual supplied with this machine before operation or service.

Modification or alteration of this machine **CAN** result in severe injury or death. Do not alter or modify this machine without the express written consent of the manufacturer.

 **CAUTION**

Exercise extreme caution when using booster battery. To jump battery, connect ends of one booster cable to the positive (+) terminal of each battery. Connect one end of other cable to the negative (-) terminal of the booster battery and other end to a ground connection away from dead battery (to avoid a spark occurring near any explosive gases that may be present). After starting unit, always disconnect cables in reverse order.

 **WARNING**

Never inspect or service unit without first disconnecting battery cable(s) to prevent accidental starting.

Wear eye protection while cleaning unit with compressed air, to prevent debris from injuring eyes.

 **WARNING**

HOT PRESSURIZED FLUID - Remove cap slowly to relieve **PRESSURE** from **HOT** radiator. Protect skin and eyes. **HOT** water or steam and chemical additives can cause serious personal injury.

 **WARNING**

Flammable Fuels - Do not fill tank when engine is running.

Do not smoke or use an open flame in the vicinity of the generator set or fuel tank.

Do not permit smoking, open flame, or sparks to occur near the battery, fuel, cleaning solvents or other flammable substances and explosive gases.

Do not operate Genset if fuel has been spilled inside or near the unit.

 **WARNING**

Electrical Shock -

Do not operate electrical equipment while standing in water, on wet ground or with wet hands or shoes.

Use extreme caution when working on electrical components. Battery voltage (12V/24V DC) is present unless the battery cables have been disconnected. Higher voltage (potentially 480V) is possibly present at all times.

 **WARNING**

Always treat electrical circuits as if they were energized.

Disable Start Control before attempting any repair service, disconnect all leads to electrical power requirements and disconnect battery to prevent start up.

GROUNDING

Depending upon your application, it may be MANDATORY to ground this unit to earth or to NOT ground this unit to earth. Comply with local electrical codes and Operation Manual.

**WARNING**

The Generator Set can produce high voltages, which can cause severe injury or death to personnel and damage to equipment. The Generator Set should have proper internal and external ground when required by the National Electric Code.

The Generator Set is internally grounded neutral to the frame of the Generator Set. This internal ground connection is essential for proper Generator Set performance and personal protection.

External grounding consists of connecting the generator neutral to a solid earth ground, and is the responsibility of the operator, when grounding is required by National Electrical Code, Article 250, and other local codes as applicable. Several methods are employed to externally ground portable generator sets, depending on the intended use and code requirements. In all cases, a continuous length of splice-free copper cable, no smaller than AWG#8, shall be used for the external ground conductor, when grounding is required.

A qualified, licensed electrical contractor, knowledgeable in local codes, should be consulted.

The Generator Set has two main applications:

(1) If the Generator Set is supplying electrical power to portable equipment, the vehicle frame shall NOT be grounded to earth per National Electrical Code, Article 250-34(b). All other provisions of the Article shall be complied with.

(2) If the Generator Set is connected to a temporary or fixed distribution system (such as a building), grounding of the vehicle frame is required at the service entrance to the building, per National Electrical Code, Article 250-20 (b).

If the Generator Set is supplying power to more than one temporary or fixed wiring system, a separate ground cable must be connected from the generator neutral to each distribution systems ground as detailed above.

**WARNING**

Failure to properly ground the Generator Set can result in severe injury or death.

IF USED AS ALTERNATE POWER SUPPLY

Connect only after the main service entrance switch has been DISCONNECTED and LOCKED OPEN. In addition, circuit overload protection must be provided in accordance with National Electrical Codes and local regulations.

 **WARNING****TOWING -**

Do not tow this unit in excess of 65 mph (104 km/hr).

Do not tow this unit with a vehicle whose towing capacity is less than the gross vehicle weight.

Steps for determining correct load limit -

1. Locate the statement “The weight of cargo should never exceed xxx kg or xxx lbs” on your vehicle’s placard.
2. This figure equals the available amount of cargo and luggage load capacity.
3. Determine the combined weight of luggage and cargo being loaded on the vehicle. That weight may not safely exceed the available cargo and luggage load capacity.

Always make sure the wheels, tires and towbar connectors are in safe operating condition and tow bar is properly connected before towing.

Check the wheels of the unit when it is not connected to the tow vehicle.

Do not store or transport material or equipment in or on the unit.

 **WARNING****Drawbar/Hitch Hookup -**

Safety chains must be crossed under drawbar and attached to towing vehicle to prevent drawbar from dropping to ground in event of coupling failure.

⚠ WARNING

If the drawbar is removed from this machine, use new OEM fasteners, thread locking compound and torque per the tables included in this manual, when re-installing the drawbar.

⚠ WARNING

Voltage Selection - Do not turn Voltage Selector Switch while engine is running. Voltage selection, adjustment and electrical connections shall be performed only by qualified personnel.

⚠ CAUTION

Welding -

Prior to any welding, disconnect alternator relays, diagnostic circuit board, voltage regulator circuit board, meters, circuit breakers and battery cables. Open all circuit breakers, and remove any external connections (except grounding rod). Connect the welding ground as close as possible to the area being welded.

⚠ WARNING

Electrical Loading -

Never make electrical connections with the unit running.

Before placing the unit in operation, verify the electrical rating of the Generator Set and do not exceed generator set ratings.

**CAUTION**

Use extreme care to avoid contacting hot surfaces (engine exhaust manifold and piping).

HAZARDOUS SUBSTANCE PRECAUTION

Ensure that adequate ventilation of the cooling system and exhaust gases is maintained at all times.

The following substances are used in the manufacture of this machine and may be hazardous to health if used incorrectly.

Avoid ingestion, skin contact and breathing fumes for the following substances: Antifreeze, Engine Lubricating Oil, Preservative Grease, Rust Preventative, Diesel Fuel and Battery Electrolyte.

The following substances may be produced during the operation of this machine and may be hazardous to health:

- Avoid build-up of engine exhaust fumes in confined spaces.
- Avoid breathing exhaust fumes.
- Avoid breathing brake lining dust during maintenance.
- Always operate in a well ventilated area.



General Data

General Data

Unit Model:

UNIT MODEL	G10A	G25B, G25C	G40B, G40C	G60
Engine Speed - RPM	1800	1800	1800	1800
ENGINE	Diesel	Diesel	Diesel	Diesel
Manufacturer	IR	IR	IR	JD
Model	3IRL2N	4IRQ2N	4IRS2N	5030TF270
FLUID CAPACITIES				
Engine Crankcase Lubricant	.98	1.7 gal	2.64 gal	2.96 gal
Fuel Tank	21	36 gal	47 gal	103 gal
Radiator & Engine Coolant	2.0	4 gal	5 gal	6 gal
Electrical System	12VDC	12VDC	12VDC	12VDC
RUNNING GEAR				
Tire Size	ST175/80D13	ST205/75D15	ST205/75D15	ST205/75D15
Inflation Pressure (Cold)	50 psi	50 psi	50 psi	50 psi
Towing Speed (Maximum)	65 mph	65 mph	65 mph	65 mph
UNIT MEASUREMENTS/ WEIGHTS (w/running gear)				
Overall length (inches)	121	131	143	156
Overall width (inches)	56	60	66	69
Overall height (inches)	43	67	72	85
Track width (inches)	48	50	56	60
Weight (with fuel)	1708 lbs	2588 lbs	3508 lbs	4658 lbs
Weight (less fuel)	1529 lbs	2420 lbs	3078 lbs	3895 lbs

Unit Model:

UNIT MODEL	G70A	G80A	G90A	G125	G145B	G185
Engine Speed - RPM	1800	1800	1800	1800	1800	1800
ENGINE	Diesel	Diesel	Diesel	Diesel	Diesel	Diesel
Manufacturer	JD	JD	JD	JD	JD	JD
Model	4045 TF285E	4045 TF275	4045 HF285	6068 TF275-123	4045 HF485	6068 HF285
FLUID CAPACITIES						
Engine Crankcase Lubricant	3.57 gal	3.57 gal	3.57 gal	3.57 gal	3.57 gal	8.59 gal
Fuel Tank	103 gal	103 gal	190 gal	145 gal	190 gal	255.3 gal
Engine Coolant Only	6 gal	6 gal	3.1 gal	5.3 gal	3.1 gal	3.1 gal
Electrical System	12VDC	12VDC	12VDC	12VDC	12VDC	12VDC
RUNNING GEAR						
Tire Size	ST205/ 75D15	ST205/ 75D15	ST205/ 75D15	ST205 75D15	ST205 75D15	9.50-16.5 LT/E
Inflation Pressure (Cold)	50 PSI	50 PSI	50 PSI	50 psi	50 psi	50 psi
Towing Speed (Maximum)	65 mph	65 mph	65 mph	65 mph	65 mph	65 mph
UNIT MEASUREMENTS/ WEIGHTS (w/running gear)						
Overall length (inches)	156	156	165	166	166	204
Overall width (inches)	69	69	71	72	72	76
Overall height (inches)	85	85	84	80	84	95
Track width (inches)	60	60	63	64	63	61.7
Weight (with fuel)	5105 lbs	5174 lbs	6466 lbs	5632 lbs	7220 lbs	9166 lbs
Weight (less fuel)	4435 lbs	4478 lbs	5004 lbs	4518 lbs	5758 lbs	7205 lbs

Unit Model:

UNIT MODEL	G240	G290	G450	G570
Engine Speed - RPM	1800	1800	1800	1800
ENGINE	Diesel	Diesel		
Manufacturer	JD	Cummins	Cummins	Cummins
Model	6068HF485	QSL9G3	QSX15	QSX15
FLUID CAPACITIES				
Engine Crankcase Lubricant (gal)	8.59 gal	7 gal	24	24
Fuel Tank (gal)	255.3 gal	389.5 gal	652	652
Engine Coolant Only (gal)	3.1 gal	2.91 gal	15	15
Electrical System VDC	12VDC	24VDC	24VDC	24VDC
RUNNING GEAR				
Tire Size	9.50-16.5 LT/E	9.50-16.5 LT/E	9.50 -16.5 LT/E	9.50 -16.5 LT/E
Inflation Pressure (Cold) psi	50 PSI	50 PSI	75	75
Towing Speed (Maximum)	65 mph	65 mph	65 mph	65 mph
UNIT MEASUREMENTS/ WEIGHTS				
Overall length (in/mm)	204	221	261/6626	261/6626
Overall width (in/mm)	76	78	86/2181	86/2181
Overall height (in/mm)	95	111	120/3042	120/3042
Track width (in/mm)	65	68.5	74/	74/
Weight (with fuel) lbs	9678 lbs	11,957 lbs	18271	18573
Weight (less fuel) lbs	7717 lbs	8989 lbs	13868	14170

Consumables Service Parts:

For Models:	G10A	G25B	G40B	G60	G70A	G80A	G125
Air Cleaner Element (Engine) primary	36890135	35393685	35393685	54471834	54471834	54471834	54717145
Air Cleaner Element (Engine) secondary - optional	NA	NA	NA	NA	54471842	NA	54717152
Engine Oil Filter Element	85426849	85426856	22712467	22545867	22206148	22206148	22206148
Fuel Water Separator Element	54525530	54525530	54525530	54525530	22969265	54525530	54468178
Engine Fuel Element	85426815	85426823	22712475	22556138	22969257	22206197	22206197
Inline Fuel Filter	NA	NA	NA	NA	NA	NA	NA
MAINTENANCE KITS							
250 hour Maintenance Kit (without fluids)	44003929	44003945	44000404	44003960	44029098	44003986	44003986
250 hour Maintenance Kit (& engine fluids)	44003648	44003663	44000388	44003705	44029072	44003721	44003747
500 hour Maintenance Kit (without fluids)	44003937	44003952	44000412	44003978	44029106	44003994	44004000
500 hour Maintenance Kit (& Engine fluids fluids)	44003655	44003671	44000396	44003713	44029080	44003739	44003754
Protec Eng Fluid - 5 gal	54480918	54480918	54480918	54480918	54480918	54480918	54480918
Protec Eng Fluid -1 gal	36875938	36875938	36875938	36875938	36875938	36875938	36875938

Consumable Service Parts:

For Models:	G450	G570				
Air Cleaner Element (Engine) primary	36864361	36864361				
Air Cleaner Element (Engine) secondary - optional	36864379	36864379				
Engine Oil Filter Element	54662028	54662028				
Fuel Water Separator Element	22201396	22201396				
Engine Fuel Element	54662036	54662036				
MAINTENANCE KITS						
250 hour Maintenance Kit (without fluids)	44020279	44020295				
250 hour Maintenance Kit (& engine fluids)	44020212	44020238				
500 hour Maintenance Kit (without fluids)	44020287	44020303				
500 hour Maintenance Kit (& Engine fluids fluids)	44020220	44020246				
Protec Eng Fluid - 5 gal	54480918	54480918				
Protec Eng Fluid -1 gal	36875938	36875938				

Expendable Service Parts:

For Models:	G90A	G145B	G185	G240	G290
Air Cleaner Element (Engine) primary	54471834	54717145	54717145	22119168	89288971
Air Cleaner Element (Engine) secondary - optional	NA	54717152	54717152	22119176	89288989
Engine Oil Filter Element	22206148	22206148	22206148	22206148	22177737
Fuel Water Separator Element	54525530	22969265	22969265	22969265	22637904
Engine Fuel Element	22206197	22969257	22969257	22969257	22765325
MAINTENANCE KITS					
250 hour Maintenance Kit (without fluids)	TBD	44016038	44016038	44016038	44020253
250 hour Maintenance Kit (& engine fluids)	TBD	44016004	44016004	44016004	44020196
500 hour Maintenance Kit (without fluids)	TBD	44016046	44016046	44016020	44020261
500 hour Maintenance Kit (& Engine fluids fluids)	TBD	44016012	44016012	44016053	44020204
Protec Eng Fluid - 5 gal	TBD	54480918	54480918	54480918	54480918
Protec Eng Fluid -1 gal	TBD	36875938	36875938	36875938	36875938





Operating Instructions

Operating Instructions

Never operate unit without first observing all safety warnings and carefully reading the operation and maintenance manual shipped from the factory with this machine.

BEFORE TOWING

WARNING

Failure to follow these instructions can cause severe injury or death.

CAUTION

- Position the tow vehicle to align its hitch with the pintle eye or coupler.
- Engage the parking brake and chock the wheels of the tow vehicle.
- Stand to the side and ensure pin is **FULLY** inserted (secure) in tube of jack.
- Crank jack to lower pintle eye coupler onto the hitch and to raise foot off the ground. Pull pin from tube of jack. Fold jack handle down and forward. Swing up jack tube and **FULLY** insert pin in tube.
- Connect machine towing lights to tow vehicle.
- Remove chocks from tow vehicle wheels.

Steps for determining correct load limit -

1. Locate the statement "The weight of cargo should never exceed xxx kg or xxx lbs" on your vehicle's placard.
2. This figure equals the available amount of cargo and luggage load capacity.
3. Determine the combined weight of luggage and cargo being loaded on the vehicle. That weight may not safely exceed the available cargo and luggage load capacity.

TOWING

WARNING

Failure to follow these instructions can cause severe injury or death.

- Ensure that tires, wheels and running gear are in good condition and secure.
- Ensure that tires are inflated to 50 psi.
- Do not tow this unit in excess of 65 mph (104 km/hr).
- Use a tow vehicle whose towing capacity is greater than the gross weight of this unit.
- Adjust hitch to assure machine is level for towing.

SETTING UP

Place the unit in an open, well ventilated area. Position as level as possible. The design of these units permits a 15 degree limit on out-of-level operation.

When the unit is to be operated out-of-level, it is important to keep the engine crankcase oil level near the high level mark (with the unit level).

DISCONNECT

- Set the vehicle parking brake. Chock wheels of unit.
- Disconnect machine towing lights from tow vehicle.
- Standing to the side, remove pin from tube of jack. As jack tube swings down, FULLY insert pin in the tube.
- Disconnect safety chains. Crank jack to raise eye or coupler from hitch. Tow vehicle can be moved.

BEFORE STARTING

1. Ensure load wiring connections are tight.
2. Check for fluid leaks.
3. Check for fluid level in container base.
4. Check engine oil and coolant level.
5. Check proper grounding circuit. Refer to Safety-Grounding.
6. Check for frayed or loose fan belts, hoses or wiring insulation.
7. Check for leaves, paper, debris in air vents.
8. Check Fuel Level. Add CLEAN diesel fuel.

 **WARNING**

Do not remove the cap from a HOT engine radiator. The sudden release of pressure from a heated cooling system can cause severe injury or death.

STARTING (AUTOSTART MODELS) **CAUTION**

Use the **EMERGENCY STOP** button **ONLY** in the event of an emergency. **NEVER** use it for normal shut-down.

Verify the following:

1. All external electrical power loads are turned "OFF".
2. Main Breaker is "OFF".
3. Battery Disconnect Switch is "ON".
4. Ensure that both the VOLTAGE SELECTOR (if equipped) and DIRECT HOOK-UP Doors are closed:
5. Reset (pull to unlatch) Emergency Stop Button.
6. Push the Engine "START" Button.
7. Wait for preheating if enabled.

 **CAUTION**

Do **NOT** use engine starting fluids.

 **DANGER**

POWER is present upon cranking the engine.

 **CAUTION**

Allow starter to cool for one minute between start attempts. If engine does not start after a few attempts, refer to Trouble Shooting Section.

If engine shuts down, diagnostic lamps will indicate the problem. Correct the problem before continuing.

8. Allow the engine to warm-up for 3 to 5 minutes. If the engine stops unexpectedly, refer to Trouble Shooting Section.
9. Check the CONTROL Panel for proper voltages. No RED diagnostic lamps should be glowing. Otherwise, shut down the unit and refer to Trouble Shooting.
10. With main breaker "ON" power is present and available for use.
11. Close side doors for optimum cooling of the unit while running.

STOPPING (AUTOSTART MODELS)

1. Turn off all external electrical power loads.
2. Turn Main Breaker "OFF".
3. Allow 5 minute cool down.
4. Push Engine "STOP" Button.
5. Wait at least 15 seconds before restarting.
6. Fill fuel tank at end of working day to prevent condensate.

REMOTE STARTING AND STOPPING

1. Connect the remote start contacts (located in the Generator System direct hookup compartment) to a customer-supplied contact that closes to initiate a genset start.
2. Push the Autostart Mode Switch to illuminate the Autostart Mode LED on control panel.
3. When the customer contact closes, a 10-second alarm will sound prior to each crank cycle until the engine starts. Preheating will also occur if enabled.
4. The engine will stop when the customer-supplied contact opens, and the controller will return to the Auto Start Mode.

DIAGNOSTICS/AUTO SHUTDOWN (AUTOSTART MODELS)

The operating controls and instruments are arranged on the control panel as shown. A description of each panel device is as follows:

1. **High Engine Temperature** - Indicates engine shutdown due to high coolant temperature or low coolant level.
2. **Low Engine Oil Pressure** - Indicates engine shutdown due to low engine oil pressure.
3. **Low Fuel Level** - Indicates engine shutdown due to low fuel level.
4. **High Containment Fluid Level** - Indicates high level of fluids in the containment base.
5. **Over Crank** - Indicates engine did not start after 3 cranks.
6. **Battery Not Charging** - Indicates battery voltage is low or not being charged.
7. **Engine Speed** - Indicates engine overspeed.
8. **Engine Operating** - Indicates engine is cranking or operating.
9. **Preheat** - Indicates preheating is on.
10. **Engine Communication** - Indicates the controller has communication with the engine ECU. (N/A for G20-G40).
11. **Engine Fault** - Indicates that engine service is required. (N/A for G25-G40).

ENGINE CONTROLS and INSTRUMENTS (AUTOSTART MODELS)

12. **Engine Start Switch**
13. **Engine Stop/Reset Switch** - Stops engine and resets diagnostics. Also, awakens controller from sleep mode. Wait 15 seconds for reset to complete before attempting start.
14. **Autostart Mode Switch** - Puts engine in Autostart Mode.
15. **Autostart Mode** - Indicates genset is in Autostart Mode. Note: the controller will enter low power sleep mode after a short time and all other LED's will go off.
16. **Emergency Stop Switch** - Disables running, cranking, and trips main breaker.
17. **Alarm Horn** - Sounds prior to a start when in Auto Start Mode (not visible)
18. **Diagnostic Trouble Code (DTC) Display** - Displays engine shutdown and warning codes, and text messages on electronic ECU engines.
19. **Autostart/Stop Controller**
20. **Hourmeter** - Indicates engine run hours.
21. **Battery Volts**
22. **Fuel Level**

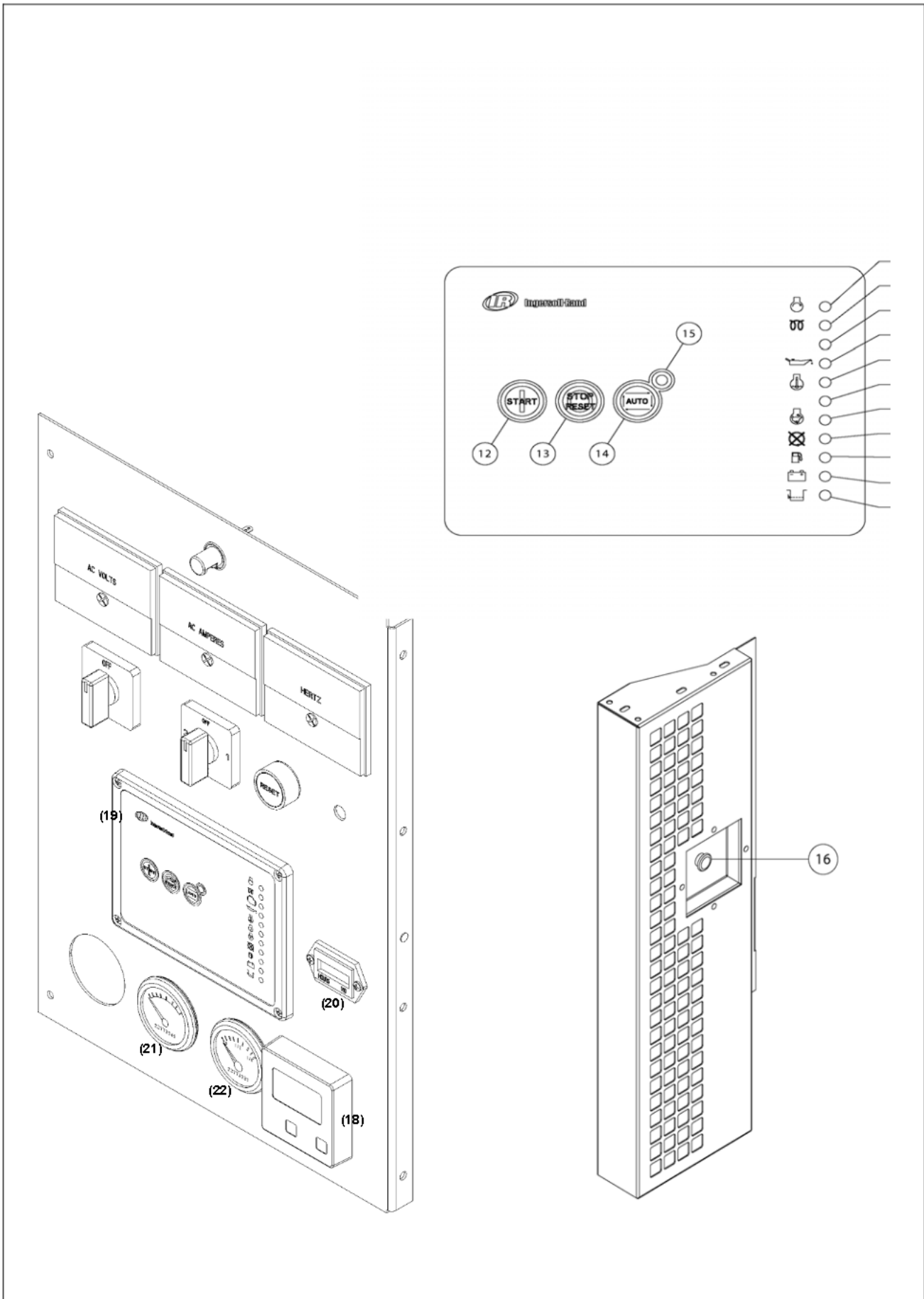

CUSTOMER - DIAGNOSTIC GAUGE OPERATION

AUTO Mode	Any active engine SPN codes are automatically deployed for 3 seconds each.
	Auto mode is default on power up.
	Press "SPN" for 3 seconds to return to AUTO mode from MANUAL mode.
	"MEM" indicator is on if engine ECU contains stored codes - Go to "MAN" mode to see codes.

MANUAL Mode	Used to see both active and stored engine codes, and to see additional SPN data (FMI, OC, SRC).
	Press "i" or "SPN" for MANUAL mode if in AUTO.
	Press "SPN" to advance to the next SPN code.
	Press "i" to get additional data on any displayed SPN.
	If the "MEM" indicator is lit, then the displayed SPN is a stored (not active) code.
	Unit will return to AUTO mode in 30 seconds.

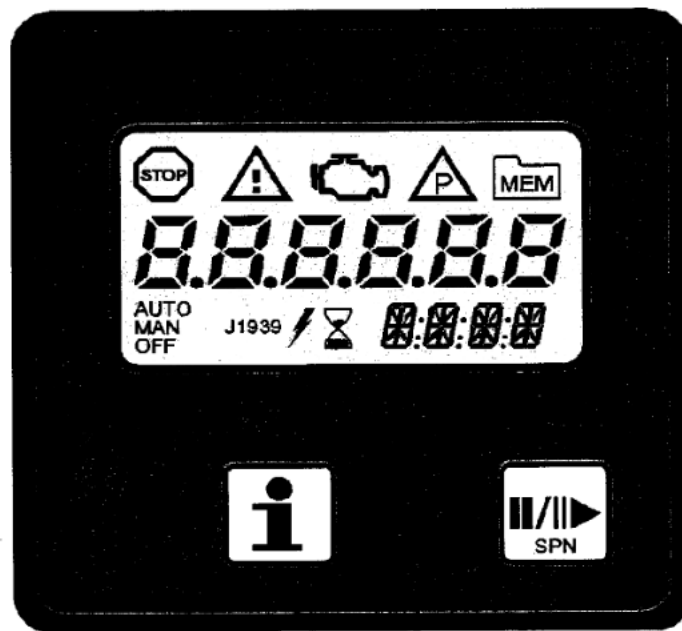

STARTING (KEY START MODELS) **CAUTION**

Use the **EMERGENCY STOP** button **ONLY** in the event of an emergency. **NEVER** use it for normal shut-down.

Verify the following:

1. All external electrical power requirements are turned "OFF".
2. Main Breaker is "OFF".
3. Battery Disconnect Switch "ON"
4. Ensure both the VOLTAGE SELECTOR (if equipped) and DIRECT HOOK-UP terminal doors are closed.
5. Reset (pull to unlatch) Emergency Stop Button.
6. Turn the ENGINE START SWITCH to "PREHEAT" for maximum of 10 seconds for cold weather starts.
7. Turn ENGINE START switch to "START". Release after engine starts.

 **CAUTION**

Do **NOT** use engine starting fluids.

 **DANGER**

POWER is present upon cranking the engine.

⚠ CAUTION

Allow starter to cool for one minute between start attempts. If engine does not start after a few attempts, refer to Trouble Shooting Section.

If engine shuts down when ENGINE START switch in in the “ON” position, diagnostic lamps will indicate the problem. Correct the problem before continuing.

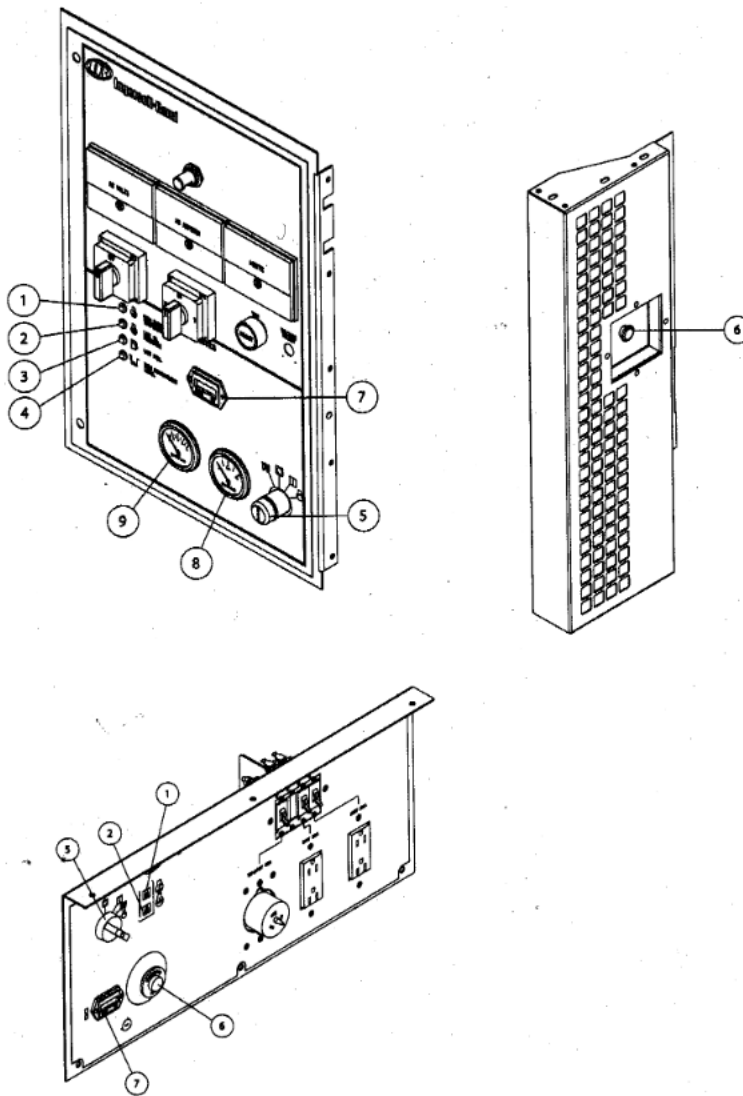

1. Allow the engine to warm-up for 3 to 5 minutes. If the engine stops unexpectedly, refer to Trouble Shooting Section.
2. Check the CONTROL Panel for proper voltages. No RED diagnostic lamps should be glowing. Otherwise, shut down the unit and refer to Trouble Shooting Section.
3. With main breaker "ON" power is present and available for use.
4. Close side doors for optimum cooling of the unit while running.

STOPPING (KEYSTART MODELS)

1. Turn off all external electrical power loads.
2. Turn Main Breaker "OFF".
3. Allow 5 minute cool down.
4. Turn the Engine Start Switch to "OFF".
5. Fill fuel tank at end of working day to prevent condensate.

DIAGNOSTICS and AUTO SHUTDOWN (KEYSTART MODELS)

On some models, the operating controls and instruments are arranged on the control panel as shown. A description of each panel device is as follows:

1. **High Engine Temperature** - Indicates engine shutdown due to high engine coolant temperature.
2. **Low Engine Oil Pressure** - Indicates engine shutdown due to low engine oil pressure.
3. **Low Fuel Level** - Indicates engine shutdown due to low fuel level.
4. **High Containment Fluid Level** - Indicates high fluid level in the containment base.

ENGINE CONTROLS and INSTRUMENTS (Keystart Models)

5. **Engine Start Switch Positions** - PREHEAT, OFF, RUN, START.
6. **Emergency Stop**- Disables running, cranking, and trips main breaker.
7. **Hourmeter** - Records operating time.
8. **Fuel Level** - Indicates fuel level in fuel tank.
9. **Voltmeter** - Indicates battery charging voltage.

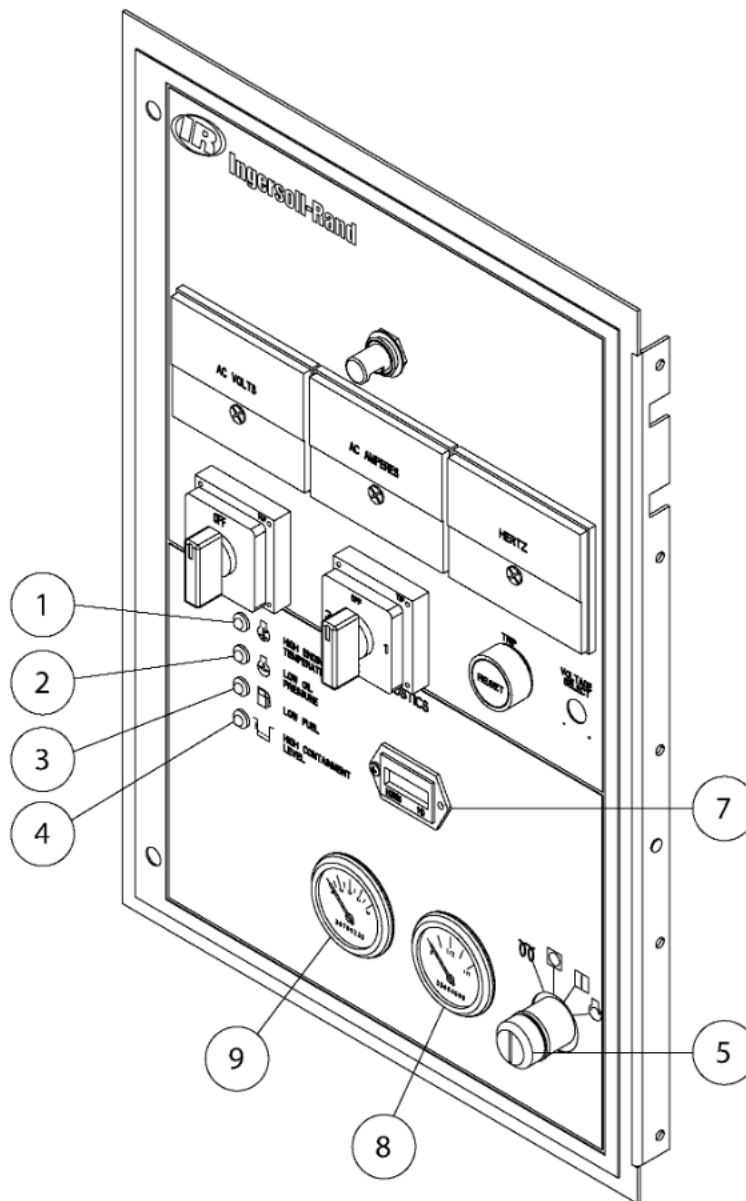

GENERATOR SYSTEM

METERS

1. **AC Volts** - Indicates the generator output voltage corresponding to VOLTAGE OUTPUT MONITOR switch position.
2. **AC Amperes** - Indicates the generator load in amperes corresponding to AMPERAGE OUTPUT MONITOR switch position.
3. **Hertz** - Indicates frequency of generator output.
4. **Panel Lamp** - Illumination Only.

MONITOR SWITCHES

5. **Voltage Output** - Selects the line to line (phase) or line to neutral (phase to neutral) generator voltage to be displayed on the AC Voltmeter.
6. **Amperage Output** - Selects the line (phase) amperage to be displayed on the AC Ammeter.
7. **Voltage Adjust Rheostat (VAR)** - Turn to adjust generator output voltage.
8. **Trip Reset Button** - Push to reset the overcurrent relay that trips the main breaker.

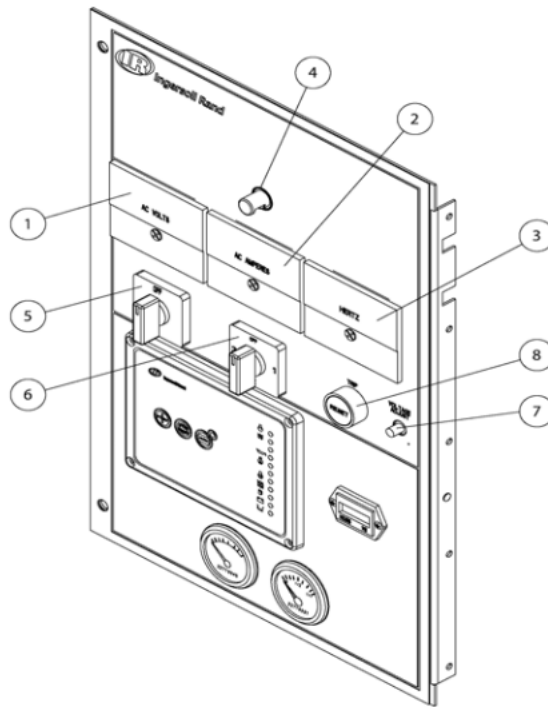

CIRCUIT BREAKERS - Flip to Reset (if equipped)

- 9. 20 AMP/120 Volt - (two)
- 10. 50 AMP/120V/240 Volt (one, two or three)

RECEPTACLES (if equipped)

- 11. 125 Volt 1 Phase - GFI, straight blade, duplex.
- 12. 125/250 VOLT 1 Phase - Special "Tempower" Twist Lock, CS-6369.

PROTECTION/REGULATION

- 13. 3 Phase Direct Hookup Connections - L₀, L₁, L₂, L₃,
- 14. Fuse Holders- Fuses for voltage output selector switch and meter. (not shown)
- 15. Overcurrent Protection Relay - (not shown) but is located behind reset button,8.
- 16. Main Circuit Breaker
- 17. Alarm Horn - (not shown) but is located on back of control box.

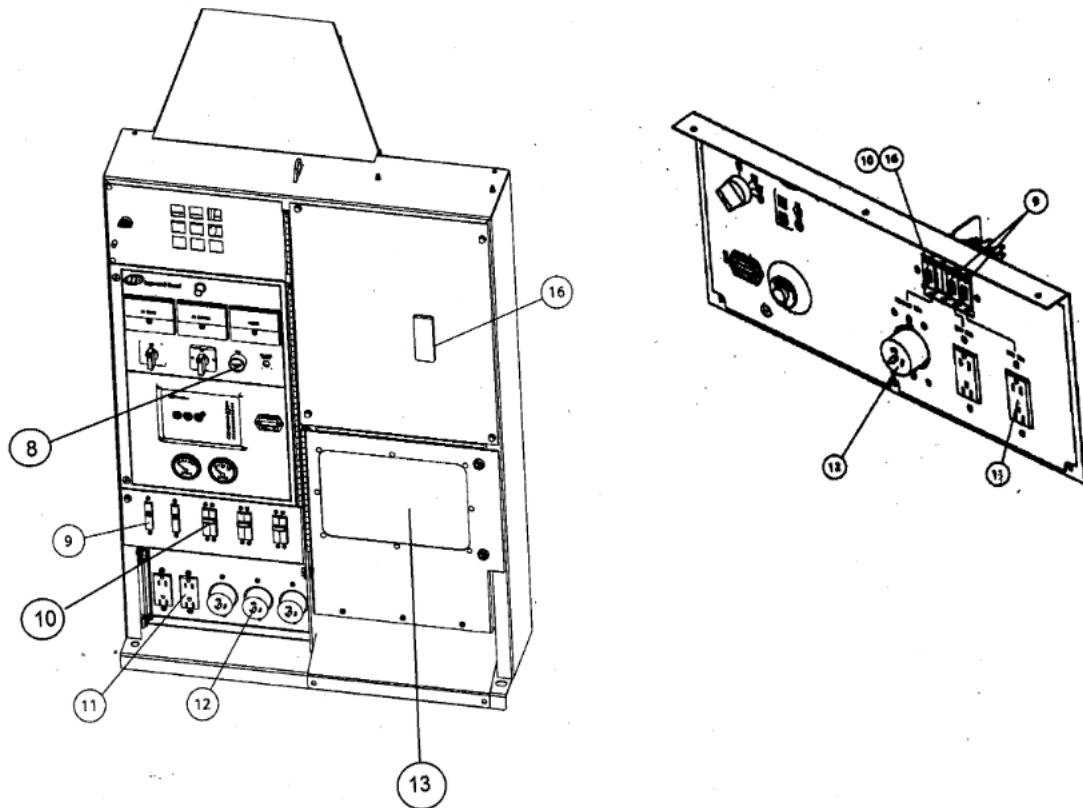

VOLTAGE SELECTION/ADJUSTMENTS G25 thru G185

DANGER

This set up procedure shall be performed only by knowledgeable qualified persons. Ensure all external electrical connections are disconnected. Use extreme CAUTION when working on electrical components. Battery voltage (12V or 24V) is present unless the battery cables are disconnected. Higher voltage (potentially 480V) is present at all times when the engine is running.

This Generator Set may be equipped with both panel convenience receptacles (120 and 240 volts, 1-phase) and direct wiring hook-ups. Any of the voltages listed below are obtainable by connection to the direct hook-up terminal block.

NOTICE

Do not hook-up electrical loads until following adjustments have been completed, otherwise damage to the equipment may result.

SET-UP PROCEDURE

Before starting and making electrical connections:

1. Open the VOLTAGE SELECTOR switch door.
2. Position the VOLTAGE SELECTOR switch to the desired voltage.
3. Close and latch the VOLTAGE SELECTOR switch door.
4. Start the unit per the Operating Section instructions.

DANGER

Electric power is present at all times when the Generator Set Engine is running.

5. Fine tuning of the VOLTAGE ADJUSTMENTS are as follows:

SWITCH POSITION - 120/208V 3 Phase

1. Turn Voltage Output Monitor to L₁-L₂ position.
2. Turn Voltage Adjust Rheostat (VAR) Shaft to read 208V on AC Voltmeter.
3. Turn Voltage Output Monitor to L₂-L₃ position and verify 208V \pm 5%.
4. Turn Voltage Output Monitor to L₃-L₁ position and verify 208V \pm 5%.
5. Power is available on all panel receptacles.
6. Turn Voltage Output Monitor to L₁-L₀ position and verify 120V \pm 5%.
7. Shutdown unit.
8. Make 120/208V connections at the direct hook-up terminal blocks.
9. At start-up, 120/208V will be present.

SWITCH POSITION - 277/480V 3 Phase

1. Turn Voltage Output Monitor to L₁-L₀ position.
2. Turn Voltage Adjust Rheostat (VAR) Shaft to read 277V on AC Voltmeter.
3. Turn Voltage Output Monitor to L₂-L₀ position and verify 277V \pm 5%.
4. Turn Voltage Output Monitor to L₃-L₀ position and verify 277V \pm 5%.
5. One of the 120V 15A or 20A panel receptacles now has power. The right duplex receptacle is "not active in 480V mode."
6. Turn Voltage Output Monitor to L₁-L₂ position and verify 480V \pm 5%.
7. Shutdown unit.
8. Make 277/480V connections at the direct hook-up terminal blocks.
9. At start-up, 277/480V will be available at the direct hook-up terminal blocks.

NOTICE

Applying single-phase loads or receptacle loads when in 3-phase switch positions can cause unbalanced loading of windings in excess of the maximum recommended, which may shorten alternator life.

SWITCH POSITION - 120/240 1Phase

1. Turn Voltage Output Monitor to L₁-L₂ position.
2. Turn Voltage Adjust Shaft to read 240V on AC Voltmeter.



Do not use L₃-L₀ due to the likelihood of equipment damage.

3. Turn Voltage Output Monitor to L₁-L₀ position and verify 120V ± 5%.
4. Turn Voltage Output Monitor to L₂-L₀ position and verify 120V ± 5%.
5. Power is available on all panel receptacles.
6. Shut down unit.
7. Make 120/240V connections at either the panel receptacles or the direct hook-up terminal blocks.
8. At start-up, 120/240V will be present.

It may be necessary to check the voltage at the end of long drop cord and increase the voltage to compensate for losses.

Voltages required other than those specified above may be adjustable within the following ranges. Follow the National Electrical Code and Local Codes. DO NOT exceed recommended voltages output to equipment.

Selector Switch Position	Voltage Adjustment Range	
	Line-Neutral	Line - Line
	L ₁ -L ₀	L ₁ -L ₂
120/208	110V-140V	190V-240V
277/480	220V-290V	380V-500V
120/240	100V-120V	190V-240V

VOLTAGE SELECTION/ADJUSTMENTS G240 thru G570** DANGER**

This set up procedure shall be performed only by knowledgeable qualified persons. Ensure all external electrical connections are disconnected. Use extreme CAUTION when working on electrical components. Battery voltage (12V or 24V) is present unless the battery cables are disconnected. Higher voltage (potentially 480V) is present at all times when the engine is running.

This Generator Set is equipped with direct wiring hook-ups. Any of the voltages listed below are obtainable by connection to the direct hook-up terminal block.

NOTICE

Do not hook-up electrical loads until following adjustments have been completed, otherwise damage to the equipment may result.

SET-UP PROCEDURE

Before starting and making electrical connections:

1. Remove the top cover on junction box (located on the AC Alternator).
2. Remove all nuts and washers from all the studs in the junction box and position the copper bars on the studs as seen in figure A for 120/208V AC or figure B for 277/480V AC.
3. Once bars are in position for the voltage you will need, reinstall nuts and washers and tighten to 50 ft lbs. and replace cover. Note: When the busbar is properly installed for either 480V or 208V, it automatically activates the control circuit Automatic Reconnect Switch located under the busbar.
4. Start the unit per the Operating Section instructions.

Figure A: Connection Chart

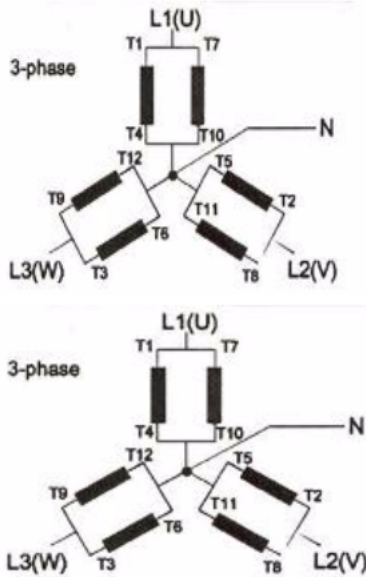

Desired Output Voltage 208/240 Output

Busbar Links
 T1-T7, T2-T8, T3-T9, T4 to T10, T5 to T11, T6 to T12
 T10 to T11 to T12

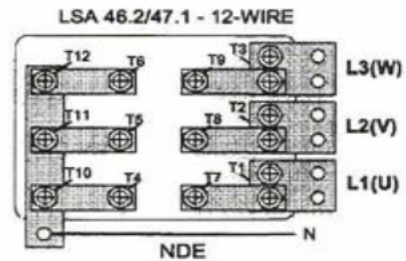
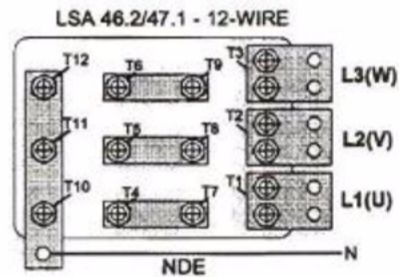
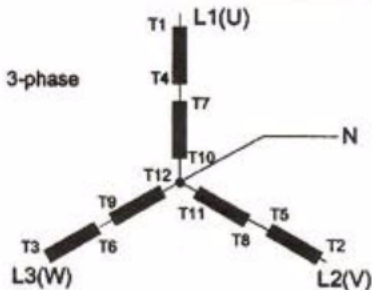

Figure B: Connection Chart

Desired Output Voltage	Busbar Links			
480V output	T4 to T7	T5 to T8	T6 to T9	T10 to T11 to T12



⚠ DANGER

Electric power is present at all times when the Generator Set Engine is running.

5. Fine tuning of the VOLTAGE ADJUSTMENTS are as follows:

120/208V 3 Phase

1. Turn Voltage Output Monitor to L₁-L₂ position.
2. Turn Voltage Adjust Rheostat (VAR) Shaft to read 208V on AC Voltmeter.
3. Turn Voltage Output Monitor to L₂-L₃ position and verify 208V ± 5%.
4. Turn Voltage Output Monitor to L₃-L₁ position and verify 208V ± 5%.
5. Turn Voltage Output Monitor to L₁-L₀ position and verify 120V ± 5%.
6. Shutdown unit.
7. Make 120/208V connections at the direct hook-up terminal blocks.
8. At start-up, 120/208V will be present.

277/480V 3 Phase

1. Turn Voltage Output Monitor to L₁-L₀ position.
2. Turn Voltage Adjust Rheostat (VAR) Shaft to read 277V on AC Voltmeter.
3. Turn Voltage Output Monitor to L₂-L₀ position and verify 277V ± 5%.
4. Turn Voltage Output Monitor to L₃-L₀ position and verify 277V ± 5%.
5. Turn Voltage Output Monitor to L₁-L₂ position and verify 480V ± 5%.
6. Shutdown unit.
7. Make 277/480V connections at the direct hook-up terminal blocks.
8. At start-up, 277/480V will be available at the direct hook-up terminal blocks.

BASIC DIGITAL CONTROLS OPERATION

Overview

Ingersoll Rand's Digital Controller is a comprehensive generator set controller that is used as the primary interface between the operator and the generator set. It provides a high degree of engine and generator protection. Multiple real-time parameters can also be viewed. The parameters include, but are not limited to kW, KVA, kVAr, power factor, oil pressure, coolant temperature, engine speed, and diagnostic history.

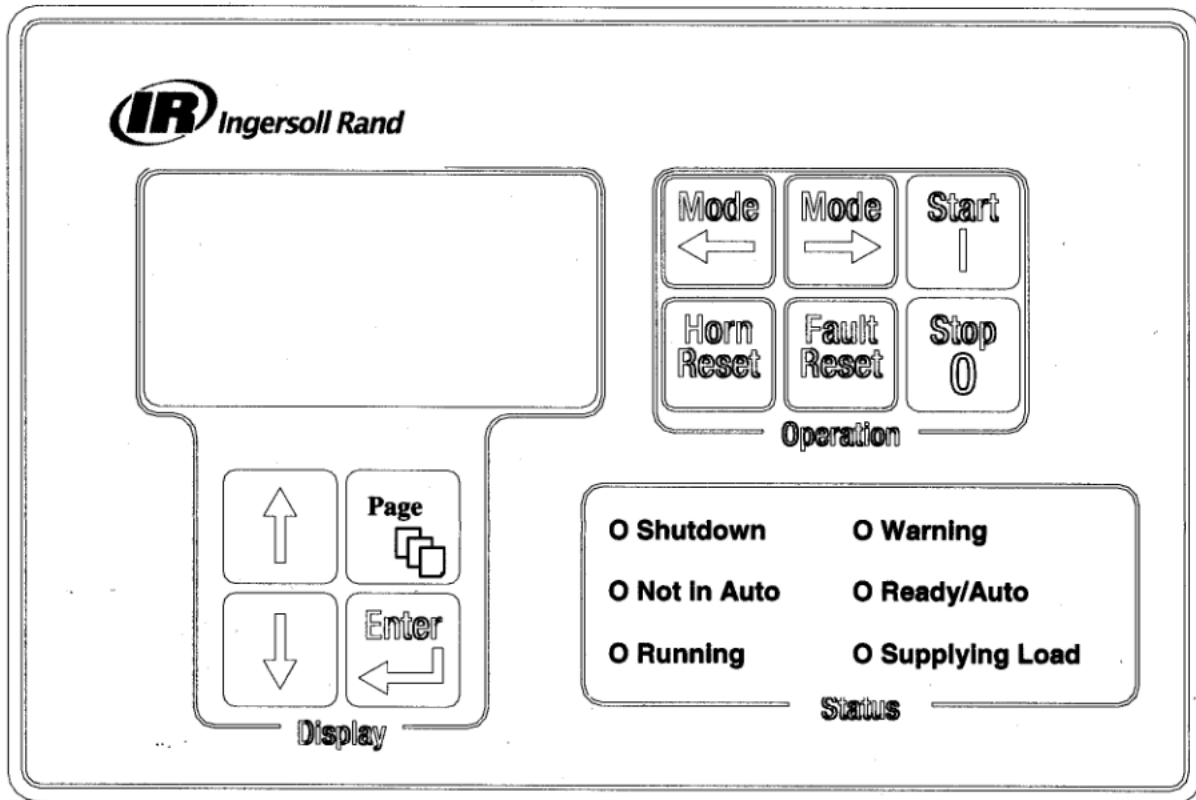

Front View of the Digital Controller

IDENTIFYING KEYPAD BUTTONS AND INDICATORS

OPERATION BUTTONS



Press this button to START the generator set.



Press this button to STOP the generator set.



Press this button to deactivate the horn.



Press this button to clear inactive faults.



Use this button to scroll the generator operation mode from OFF-MAN-AUT.



Use this button to scroll the generator operation mode from AUT-MAN-OFF.

DISPLAY BUTTONS



Use this button to scroll the display between the measurement screen, adjustment screen, and the fault screen. Use it also to back out of screens.



Use this button to select an adjustment parameter and to confirm proper adjustment.



Use this button to INCREASE setpoint values and to scroll up the adjustment menu.

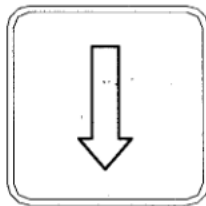

Use this button to DECREASE setpoint values and to scroll down the adjustment menu.

Status LED's

Shutdown - Indicates the generator set has shutdown due to a fault.

Not in Auto - Indicates that the generator set operation mode is not in the automatic position.

Running - Indicates that the generator set is running.

Warning - Indicates that the generator set is operating in a condition outside its normal operational parameters.

Ready/Auto - Indicates the generator set is ready and is in automatic mode.

Supplying Load - Indicates that the generator set is under load.

VIEWING REAL-TIME DATA - ACCESSING THE SCREENS

Press the  button until you reach the primary operational screen.

Use the   to scroll between screens.

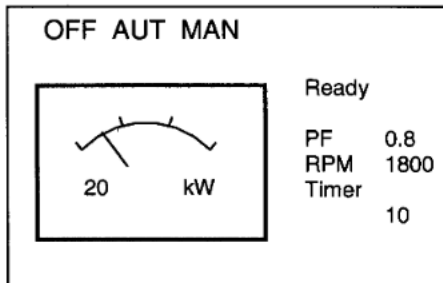

This is the primary optional screen which identifies the status of the generator set along with the generator kW, power factor, and engine RPM.

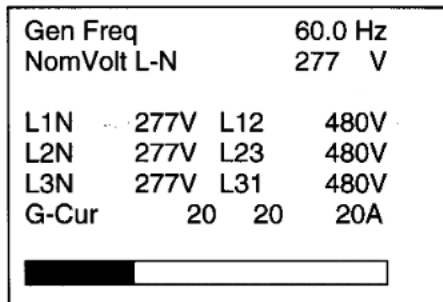

This screen displays electrical values of the generator set. These values include frequency, line voltages, phase voltages, and current per phase.

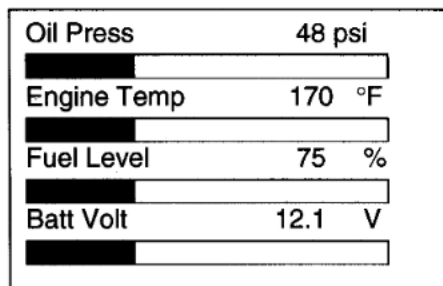

This screen displays the engine operational data of the generator set.

BIN	I000000
Rem Start/Stop	I
Low Coolant	0
Emergency Stop	0
Low Fuel	0
Full Basin	0
Voltage Select	0
VSS Door	0

This screen displays the status of the binary inputs of the controller. "I" indicates that an input has changed state and "0" indicates no change of state.

BOUT	0000I00
Starter	0
Fuel Solenoid	0
Fuel Pull Coil	0
Glow Plugs	0
IL Power	I
Horn	0
GCB Trip	0

This screen displays the status of the outputs of the controller. "I" indicates that an output has changed state and "0" indicates no change of state.

ECU State	000
ECU Yellow Lamp	0
ECU Red Lamp	0
Wait to Start	0

This screen is ONLY shown on Engines utilizing J1939 engine communications. Indication of faults/shutdowns from the engine control unit is shown here. The ECU Yellow Lamp indicates an engine warning and the ECU Red Lamp indicates an engine shutdown.

ECU Values	
Oil Pressure	xxxxx
Water Temp	xxxxx
Perc Load ATCS	xxx
Boost Pressure	xxx
Manifold Temp	xxxxx
Fuel Rate	xxxxx

This screen is ONLY shown on engines utilizing J1939 engine communications. The data is sent from the engine ECU.

Act Power			0kW
0	0		0
Pwr factor		0.00	
0.00	0.00		0.00
React pwr			0kVAr
0	0		0
Appar Pwr			0kVA
0	0		0

This screen displays the load parameters of the generator set in terms of active power, power factor, reactive power, and apparent power. These values are indicated in total and per phase.

Run Hours	0	h
NumStarts	0	
E-Stop	0	
Shutdown	0	
KW hours	0	
KVAr hours	0	
Next Srv Time	250	h

This screen displays operational information of the generator set in terms of run hours, number of starts, number of e-stops, and shutdowns, kW hours, kVAr hours. Also shown is a definable parameter for service intervals.

ECU Alarm List					
>					
...					
FC	0	OC	0	FMI	0

This screen is ONLY shown on engines utilizing J1939 Communications. The SPN and FMI diagnostic codes are shown here as sent from the engine ECU. These Faults are non latching and are not present when the Fault is not present. A full listing of Fault Codes is shown at the end of this manual.

Alarm List	2
Not in Auto	
Wrn Coolant Level	

This screen displays the alarm/shutdown list of the generator set. Inactive faults can be cleared by pressing the "Fault Reset" button. Up to eight faults can be displayed on this screen and are "first-in-first out".

CHECKING SOFTWARE VERSION/LAMP TEST

To check the software version and to test the operation of the LED's on the control panel, simultaneously press

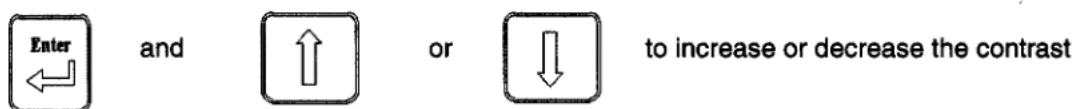

**ADJUSTING THE CONTRAST ON THE LCD**

To adjust the contrast on the LCD display, simultaneously press





PARAMETER ADJUSTMENTS VIA KEYPAD

Press the  button until you reach the parameter adjustment menu.



Use the   to scroll through the parameter menus.

```
Parameters Adjust Menu
>Password
Basic settings
Engine params
Engine protect
Gener protect
Date/Time
Sensors spec
I/O Module
```

Press  to select the desired parameter menu.

Use the   to scroll to the parameter to be adjusted.

Press  to select parameter to be adjusted. Note: Parameters preceded by an asterisk * require password access.

Use the   to increase or decrease the setpoint value.

When the desired setpoint is reached, press 

Press the  button once to get back to the parameter menu and twice more to go back to the measurement screen.

SETPOINTS DESCRIPTIONS**BASIC SETTINGS****Gen-Set Name**

User defined name, used for the CONTROLLER identification at remote phone or mobile connection. The Gen-set name is max 14 characters long and has to be entered using Lite Edit software.

Nomin Power (3ph)

Nominal power of the generator in three phase HI-WYE series connection.

Nomin Current

Nominal current of the generator in three phase LOW-WYE parallel connection.

CT Ratio

The generator set current transformer ratio.

PT Ratio

The generator set potential transformers ratio. PT's are not needed on 480 Volt systems and below.

Nominal Voltage 1

Line to neutral voltage in LOW-WYE, Parallel connection.

Nominal Voltage 2

Line to neutral voltage in HI-WYE, series connection.

Gear Teeth

Number of teeth on the engine gear for the pick-up. Set to zero, if no pick-up is used. Engine speed is counted from the generator frequency. Electronic engines get the speed signal from the engine controller.

Alternator Frequency

Frequency of the battery alternator when the controller stops cranking.

Nominal RPM

The nominal engine speed of the generator set.

Mode [OFF, MAN, AUT]

This is the equivalent of controller "Mode" buttons.

Fault Reset Go to Manual

Enables or Disables return to MAN mode when reset is pushed.

Display Backlight Timeout

The time limit in minutes for the backlight to go off.

IL Power OFF

The time limit in minutes for the controller to go to Sleep Mode. The control power is restored by pushing the Control Power Button for 5 seconds.

Controller ADDR

The setting of the controller address.

RS232 Mode

The communication protocol selection.

- Standard = Lite Edit
- Modbus = Modbus Protocol
- Cummins MB = Cummins Modbus Protocol

ENGINE PARAMETERS

Start RPM

"Firing" speed when controller stops cranking (starter goes OFF).

Starting POil

When reached, controller stops cranking (starter goes OFF). There are three conditions for stop cranking: Starting RPM, Starting POil and D+ (when enabled). The starter goes off when any of these conditions are valid.

PreHeat Time

The time delay for preheating after the unit gets the start command. The unit begins to start after preheating. Select No Preheat with a setting = 0. Factory default setting = 10 seconds.

MaxCrank time

Maximum time limit of cranking.

Crank Fail Pause

Pause time between crank attempts.

Crank Attempts

Maximum number of crank attempts.

Idle Time

Idle time delay starts when RPM exceeds Start RPM. Start fail is detected when during idle state RPM decrease below 2.

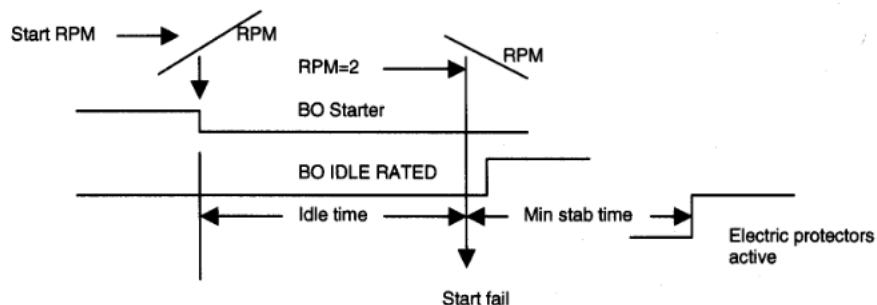

Min Stability Time

Generator nominal voltage starts being detected after starter is switched off, idle time elapses, and this time has elapsed.

Max Stability Time

If generator nominal voltage is not stable within the time after starter is OFF and idle time elapses, then the genset will shutdown. Stability means that voltage and frequency are within warning setting limits.

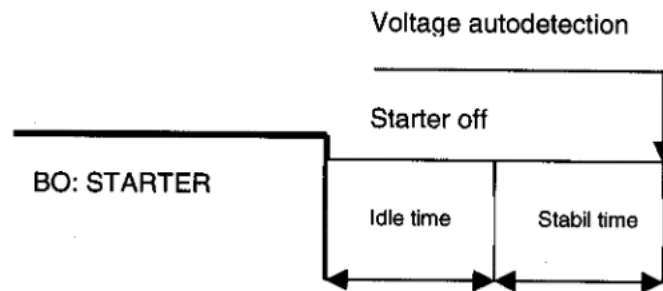

Cooling Speed

This function is not used. Reserved for future applications. Factory default setting = NOMINAL.

Cooling Time

Runtime of the unloaded generator set to cool the engine before stop.

After Cool Time

This function is not used. Factory default setting = 0.

Stop Time

When genset stop sequence is initiated, fuel solenoid output cannot activate during this time.

Fuel Solenoid

Determines behavior of the Binary output FUEL SOLENOID.

DIESEL: Output closes together with Binary output STARTER.

The output opens if Emergency stop comes or Cooled generator set is stopped or in pause between repeated starts.

GAS: Output closes together with Binary output IGNITION if RPM is over the 30 RPM (Fix value). Output opens after stop command or in pause between repeated start.

Fuel Pull Coil

Time duration that output Fuel Pull Coil is active. This output is used for momentary activation of a fuel solenoid pull coil.

D+ Function

ENABLED: The D+ terminal is used for both functions - "running engine" detection and charge fail detection.

CHRGFAIL: The D+ terminal is used for charge fail detection only.

DISABLED: The D+ terminal is not used, but still provides flash voltage to battery alternator.

ECU Freq Select

This function is not used. Factory Setting = DEFAULT.

ECU Speed Adjust

This function is not used. Factory Default Setting = 0

ENGINE PROTECTION**Eng prot del [s]**

During the start of the generator set, some engine protections have to be blocked (e.g. Oil Pressure). The protections are unblocked after the protection del time. The time starts after reaching START RPM.

Alarm Horn

Three selections possible:

NONE = Horn only sounds for 10 seconds prior to a start in Auto Mode.

SHUTDOWN = Horn sounds for any shutdown and also for an Autostart.

SD+ WARNING = Horn sounds for any alarm or shutdown and also for an Autostart.

Overspeed

Threshold for overspeed protection.

Wrn Oil Press

Warning threshold for low oil pressure.

Sd Oil Press

Shutdown threshold level low oil pressure.

Oil Press Del

Delay for oil pressure warning/shutdown.

Sd Engine Temp

Shutdown threshold level for high engine coolant temperature.

Wrn Engine Temp

Warning threshold level for high engine coolant temperature.

Wrn Eng Temp Low

Warning threshold level for low engine coolant temperature.

Engine Temp Del

Delay for high/low engine coolant temperatures.

Wrn Fuel Level

Warning threshold level for low fuel level.

Sd Fuel Level

Shutdown threshold level for low fuel level.

Fuel Level Del

Delay for low fuel level.

Batt Overvolt

Warning threshold for high battery voltage.

Batt Undervolt

Warning threshold for low battery voltage.

Battvolt del

Delay for low battery voltage alarm.

NextServTime [h]

Counts down when engine running. If reaches zero, an alarm appears.

ALTERNATOR PROTECTION

Overload

Threshold for generator overload (in % of nominal power)

Overload Wrn

Threshold for generator overload warning (in % of nominal power)

Overload del

Delay for generator overload alarm.

Ishort

Shutdown occurs when Ishort circuit limit is reached.

Ishort del

Delay for Ishort Alarm.

2Inom del

IDMT is "very inverse" generator over current protection. 2Inom del is Reaction time of IDMT protection for 200% overcurrent $I_{gen} = 2 * \text{Nominal current}$.

Curr unbal del

Delay for generator current asymmetry.

Gen >V Sd

Shutdown level for generator over voltage. All three phases are checked. Maximum out of three is used.

Gen >V Wrn

Warning level for generator over voltage. All three phases are checked. Maximum out of three is used.

Gen <V Sd

Shutdown level for generator under voltage. All three phases are checked. Minimum out of three is used.

Gen <V Wrn

Warning level for generator under voltage. All three phases are checked. Minimum out of three is used.

Gen V del

Delay for generator under voltage and over voltage alarm.

Volt unbal

Threshold for generator voltage unbalance alarm.

Volt unbal del

Delay for generator voltage unbalance alarm.

Gen >f SD

Shutdown level for generator over frequency.

Gen>f Wrn

Warning level for generator over frequency.

Gen <f Wrn

Warning level for generator under frequency.

Gen <f SD

Shutdown level for generator under frequency.

Gen f del

Delay for generator under frequency and over frequency alarm.

DATE/TIME**Time Stamp Per**

Fixed time interval when history of all parameters is recorded. Factory Default Setting = 0.

Summer Time Mod

Automatic time adjustment for daylight savings time.

Time

Time of day setting.

Date

Date setting

Timer 1 Repeat

Selection of day/days when exercise Timer 1 will run.

Timer 1 on Time

Selection of time of day when Timer 1 will start the genset.

Timer 1 Duration

Selection of length of run time.

Timer 2 Repeat

Selection of day/days when exercise Timer 2 will run.

Timer 2 on Time

Selection of time of day when Timer 2 will start the genset.

Timer 2 Duration

Selection of length of run time.



Maintenance

Maintenance

CAUTION

Any unauthorized modification or failure to maintain this equipment may make it unsafe and out of factory warranty.

WARNING

Before attempting any repair service, disconnect engine battery cables and all leads to electrical power requirements. Failure to do so can result in severe personal injury, death or damage to the equipment.

General

In addition to periodic inspections, many of the components in this unit requires periodic servicing to provide maximum output and performance. Servicing may consist of pre-operation and post-operation procedures to be performed by the operating or maintenance personnel. The primary function of preventive maintenance is to prevent failure and consequently, the need for repair. Preventive maintenance is the easiest and the least expensive type of maintenance. Maintaining your unit and keeping it clean at all times will facilitate servicing.

Scheduled Maintenance

The maintenance schedule is based on normal operation of the unit. In the event unusual environmental operating conditions exist, the schedule should be adjusted accordingly.

Wiring Routing Clamps

Daily check for loose wire routing clamps. Clamps must be secure and properly mounted. Also check wiring for wear, deterioration and vibration abrasion.

Electrical Terminals

Check daily for evidence of arcing around electrical terminals.

Grounding Circuit

Daily check that the grounding circuit is in accordance with the National Electrical Code Article 250-122 and the local code requirements. As a minimum, the copper wire size should be American Wire Gauge 8 (AWG#8) from the grounding terminal, frame, generator and engine block.

Hoses

Each month it is recommended that the intake hoses from the air cleaner and all flexible hoses used for water and fuel be inspected for the following:

1. All rubber hose joints and the screw type hose clamps must be tight and the hoses showing no signs of wear, abrasion or deterioration.
2. All flexible hoses must be free of wear, deterioration and vibration abrasion. Routing clamps must be secure and properly mounted.

Wiring Insulation

Daily check for loose, or frayed wiring insulation or sleeving.

Fuel/Water Separator

Daily check for water in the fuel filter/water separator unit. Some engines have a translucent bowl for visual indication, and others have a drain valve below the primary element.

Every six months or 500 hours, or less if fuel is of poor quality or contaminated, replace the bowl elements(s).

Air Vents

Daily clean the air vents of any obstruction or debris.

Air Cleaner

Proper maintenance of the air cleaner provides maximum protection against airborne dust. Squeeze the rubber valve (precleaner dirt dump periodically to ensure that it is not clogged).

To service the air cleaners, proceed as follows:

1. Remove filter element.
2. Inspect air cleaner housing for any condition that might cause a leak and correct as necessary.
3. Wipe inside of air cleaner housing with a clean, damp cloth to remove any dirt accumulation. This will permit better seal for gasket on filter element.
4. Install element.

The air cleaner assembly (housing) should be inspected every 3 months or 500 hours for any leakage paths.

Note: Make sure the inlet is free from obstruction.

Make sure the air cleaner mounting bolts and clamps are tight and the air cleaner is mounted securely. Check the air cleaner housing for dents or damage to the cleaner, which could lead to a leak.

Fasteners

(See following inch torque chart, metric torque chart and wheel torque chart). All fasteners should be torqued in accordance to size and grade.

Torque Chart

TABLE 2 METRIC FASTENERS

CAPSCREW OR NUT THREAD SIZE AND PITCH	NOMINAL DESIGN TORQUE					
	PROPERTY GRADE 8.8 (HEAD MARKING)		PROPERTY GRADE 10.9 (HEAD MARKING)		PROPERTY GRADE 12.9 (HEAD MARKING)	
	(Nm.)	(FT-LBF)	(Nm.)	(FT-LBF)	(Nm.)	(FT-LBF)
M6 X 1.0	11	8	15	11	18	13
M8 X 1.25	26	19	36	27	43	31
M10 X 1.5	52	38	72	53	84	62
M12 X 1.75	91	67	126	93	147	109
M14 X 2	145	107	200	148	234	173
M16 X 2	226	166	313	231	365	270
M20 X 2.5	441	325	610	450	713	526



TYPICAL RECTANGULAR TORQUE PATTERN

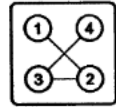

TYPICAL SQUARE TORQUE PATTERN

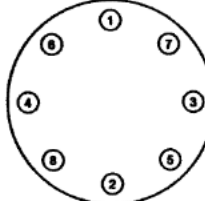

TYPICAL CIRCULAR TORQUE PATTERN

TABLE 1 INCH FASTENERS

CAPSCREW OR NUT THREAD SIZE AND PITCH	NOMINAL DESIGN TORQUE			
	SAE J249 GRADE 5 (HEAD MARKING)		SAE J249 GRADE 8 (HEAD MARKING)	
	(Nm.)	(FT-LBF)	(Nm.)	(FT-LBF)
1/4 - 20	11	8	16	12
5/16 - 18	24	17	33	25
3/8 - 16	42	31	59	44
7/16 - 14	67	49	95	70
1/2 - 13	102	75	144	106
9/16 - 12	148	109	208	154
5/8 - 11	203	150	287	212
3/4 - 10	361	266	509	376

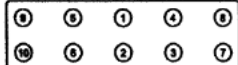

TYPICAL RECTANGULAR TORQUE PATTERN

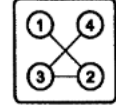

TYPICAL SQUARE TORQUE PATTERN

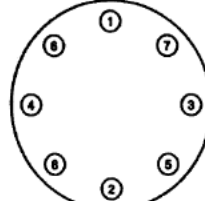

TYPICAL CIRCULAR TORQUE PATTERN

Wheel Torque Chart	
M12 Bolts	Torque (Ft-Lbs)
13" wheel	60-70
1/2" lug nuts	
13" wheel	80-90
15" wheel	105-115
16" wheel	105-115
16.5 wheel	105-115
5/8" lug nuts	
16" wheel	190-210
17.5 wheel	190-210

Tires

Weekly check the condition of the tires, and gauge the air pressure. Tires that have cuts or cracks or little tread should be repaired or replaced.

Engine Radiator

Check the coolant level in the radiator. The coolant must cover the tubes in the top tank (approximately 1 inch high on a clean measuring rod, stuck down filler neck).

WARNING

Remove cap slowly to relieve pressure from HOT radiator. Protect skin and eyes. Hot water or steam and chemical additives can cause serious personal injury.

The engine coolant system is normally filled with a 50/50 mixture of water and ethylene glycol. This permanent type anti-freeze contains rust inhibitors and provides protection to -35°F (-37°C). The use of such a mixture is recommended for both summer and winter operation. When using water alone, be sure to add a reputable brand of rust inhibitor to prevent internal corrosion.

It is recommended to test the freezing protection of the coolant every six months or prior to freezing temperatures. Replenish with a fresh mixture every twelve months.

Each month, inspect the radiator exterior for obstructions, dirt and debris. If present, blow water or compressed air containing a non-flammable solvent between the fins in a direction opposite the normal air flow. Should the radiator be clogged internally, reverse flushing, using a commercial product and the supplier's recommended procedure, may correct the problem.

Diagnostic Lamps

On Keystart models, each month the diagnostic lamps should be tested. With unit shutdown and emergency stop pushed, turn the Engine Start Switch to "START", or pull the ESTOP to apply power to the controller. All diagnostic lamps should glow; if not, refer to troubleshooting.

Diagnostic Trouble Code (DTC) Display

On models with Electronic (ECU) engines, each month, the DTC display should be tested. When unit is started, the DTC Display should show dashes (----) or a trouble code if there is a fault condition.

Emergency Stop Switch

Each month, check the operation of the emergency stop switch. Running with no electrical loads and the main breaker "ON", press the EMERGENCY STOP SWITCH. The unit should shutdown immediately and the main breaker should trip with cranking disabled. Emergency Stop Switch must be reset (pull to unlatch) for operation.

Voltage Selector Door Interlock Switch

Every three months or 250 operating hours, the interlock switch should be checked. Running with no electric load, open the VOLTAGE SELECTOR door. This will shutdown the engine and trip the main breaker. To reset, close the door.

Engine Protection Shutdown System

The operation of the engine protection shutdown system should be checked, whenever it appears not to be operating properly. The three devices involved in this protective shutdown system are the engine coolant high temperature switch/sensor, the engine oil pressure switch/sensor and the low fuel switch.

The engine oil pressure switch/sensor prevents the engine from operating with low oil pressure. Once a month, remove a wire from the engine oil pressure switch/sensor to check the shutdown system for proper operation. Do the same for the wire on the engine temperature switch/sensor.

High Containment Fluid Alarm System

The operation of the high containment fluid alarm system should be checked every 3 months or whenever it appears not to be operating properly.

The level switch is located at the lower end of a pipe at the bottom of the containment tank.

Test the switch by unfastening the u-bolts holding the pipe, and then inverting the pipe to allow the switch float to fall.

The "High Containment Level" LED should illuminate. Replace any defective switch.

Drain the containment area using the drain plug at either end of the containment basin.

ADJUSTMENT INSTRUCTIONS and TESTING PROCEDURES

ACCESSING COMPARTMENT

1. Disconnect all electrical loads to the unit.



High Voltage is present in alternator and control compartments when engine is running. Battery voltage is present whenever battery is connected.

2. With engine stopped, remove the plate on the left side or front of the alternator junction box.

VOLTAGE REGULATOR ADJUSTMENT

Refer to ACCESSING COMPARTMENT Section and Figure 8-1 for locations.

1. With all electric loads disconnected, engine stopped and main breaker turned on, turn VOLTAGE SELECTOR Switch to 277/480V position, and close and latch the VSS door.
2. Adjust "Voltage" POT(P2) on regulator to full counterclockwise position.
3. Adjust "Voltage" POT on control panel to full clockwise position.
4. Start unit.
5. Verify generator frequency to 62-63 Hz at no load on G10 - G40, 60-60.5 Hz on G60 - G570.
6. Set the VOLTAGE OUTPUT MONITOR switch on the control panel to L₁-L₂ position.
7. Adjust "VOLTAGE" POT(P2) on the regulator to read 500V on AC voltmeter.
8. Adjust "Stability" POT(P3) counter clockwise until the AC volts within ± 1 volt. Then turn the adjusting "Stability" POT (P3) some 5-10 degrees clockwise.
9. Adjust "Voltage" POT on control panel to read 480V on AC voltmeter.
10. Stop Generator Set.
11. Check the range in each VOLTAGE SELECTOR switch position (120/208, 120/240 and 277/480).

OVERCURRENT RELAY ADJUSTMENT (Set Dial on the OCR Relay)

Overcurrent Relay Adjustment		
KVa	Setting \pm 0.1	AMPS
25	2.1	34
40	2.3	47
60	1.9	77
70	1.9	96
80	2.2	109
90	2.4	124
125	2.1	165
145	2.4	190
185	2.0	242
240	2.0	314
290	1.9	384
315	2.1	415
450	2.0	603
570	2.4	754

POWER BYPASS SWITCH FOR ENGINE ECU SERVICE

Push the Power Bypass Switch to temporarily apply power to the engine ECU during engine computer diagnostics on a stopped engine. The switch is located on the side of the engine next to the Can Bus diagnostic connector.

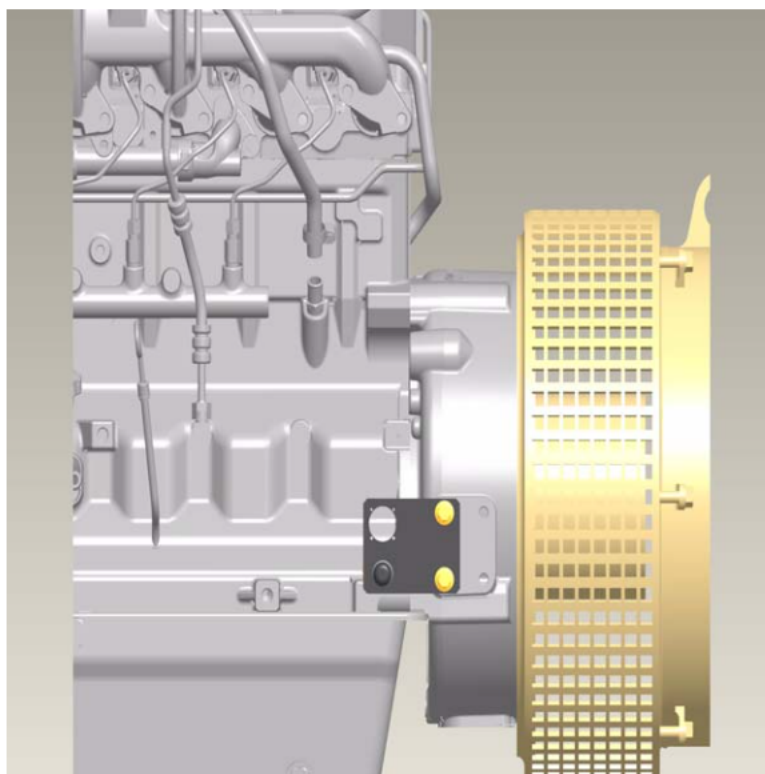

PACKAGE PREVENTIVE MAINTENANCE SCHEDULE

	Daily	Weekly	Mon.	3 Mon. 250 hrs	6 Mon. 500 hrs	12 Mon. 1000 hrs
Evidence of Arcing around electrical terminals	C					
Loose Wire Routing Clamps	C					
Engine Oil and Coolant Level	C					
Proper Grounding Circuit	C					
Instruments	C					
Frayed/Loose Fan belts, hoses, wiring insulation	C					
Fuel/Water Separator	drain					
Precleaner Dumps		C				
Tires		C				
Battery Connections		C				
Engine Radiator (exterior)			C			
Air Intake Hoses and Flexible Hoses			C			
Fasteners (tighten)			C			
Emergency Stop Switch Operation			C			
Engine Protection Shutdown System			C			
Diagnostic Lamps			C			
Voltage Selector/Interlock Switches				C		
High Containment Fluid Alarm System				C		
Air Cleaner Housing				C		
Control Compartment (Interior)					C	
Fuel Tank (fill at end of each day)					drain	
Fuel/Water Separator Element					R	
Wheel Bearings & Grease Seals					repack	
Engine Shutdown System Switches (setting)						C
Exterior Finish	As needed					
Engine	Refer to Engine Operation Section					
Decals	Replace decals if removed, damaged or missing					
C = Check (and adjust or replace if necessary)						
WI = OR when indicated						
R = Replace						
Unit:	Hours:					
Date:	Serviceman:					



Alternator Installation and Maintenance

Leroy Somer Alternator LSA 42.2/43.2/44.2/46.2/47.2 - 4 POLE

This section concerns the alternator used in the generator set, which you have just purchased.

We wish to draw your attention to the contents of this maintenance section. By following certain important points during installation, use and servicing of your alternator, you can look forward to many years of trouble-free operation.

Our alternators comply with most international standards and are compatible with:

- The recommendations of the International Electrotechnical Commission IEC 34-1, (EN60034).
- The recommendation of the International Standards Organization ISO 8528.
- The European Community directive on Electromagnetic Compatibility (EMC) 89/336/EEC).
- The European Community directives 73/23/EEC and 93/68/EEC (Low Voltage Directive).

The are CE marked with regard to the LVD (Low Voltage Directive) in their role as a machine component. A declaration of incorporation can be supplied on request.

SAFETY MEASURES

Before using your machine for the first time, it is important to read the whole of this installation and maintenance manual.

All necessary operations and interventions on this machine must be performed by a qualified technician.

Our technical support service will be pleased to provide any additional information you may require.

The various operations described in this manual are accompanied by recommendations or symbols to alert the user to potential risk of accident. It is vital that you understand and take notice of the different warning symbols used.



Warning symbol for an operation capable of damaging or destroying the machine or surrounding equipment.

 **WARNING**

Safety symbol for an operation capable of damaging or destroying the machine or surrounding equipment or danger to personnel.



Safety symbol for electrical danger to personnel.



Identification

The alternator is identified by means of a nameplate glued to the frame. Make sure that the nameplate on the machine conforms to your order. The machine name is defined according to various criteria (see below).

Example of description: LSA 43.2 M45 J6/4

- LSA: Name used in the PARTNER range
- M: Marine
- C: Cogeneration
- T: Telecommunications
- 43.2: Machine Type
- M45: Model
- J: Excitation System (C: AREP/J: SHUNT or PMG/E: COMPOUND)
- 6/4: Winding number/number of poles

Nameplate

So that you can identify your machine quickly and accurately, we suggest you fill in its specifications on the nameplate below.

ALTERNATEURS PARTNER ALTERNATORS																																																				
<table border="1" style="width: 100%;"> <tr> <td>LSA</td> <td>Date</td> </tr> <tr> <td>N°</td> <td>Hz</td> </tr> <tr> <td>Min-1/R.P.M.</td> <td>Protection</td> </tr> <tr> <td>Cos φ / P.F.</td> <td>Cl. ther. / Th. class</td> </tr> <tr> <td>Régulateur/A.V.R.</td> <td></td> </tr> <tr> <td>Altit. ≤</td> <td>Masse / Weight</td> </tr> <tr> <td>Rit AV/D.E bearing</td> <td></td> </tr> <tr> <td>Rit AR/N.D.E bearing</td> <td></td> </tr> <tr> <td>Graisse / Grease</td> <td></td> </tr> <tr> <td>Valeurs excit / Excit. values</td> <td></td> </tr> <tr> <td>en charge / full load</td> <td></td> </tr> <tr> <td>à vide / at no load</td> <td></td> </tr> </table>	LSA	Date	N°	Hz	Min-1/R.P.M.	Protection	Cos φ / P.F.	Cl. ther. / Th. class	Régulateur/A.V.R.		Altit. ≤	Masse / Weight	Rit AV/D.E bearing		Rit AR/N.D.E bearing		Graisse / Grease		Valeurs excit / Excit. values		en charge / full load		à vide / at no load		<table border="1" style="width: 100%;"> <tr> <th colspan="3">PUISSANCE / RATING</th> </tr> <tr> <td>Tension Voltage</td> <td></td> <td>V</td> </tr> <tr> <td>Connex.</td> <td></td> <td>Ph.</td> </tr> <tr> <td>Continue</td> <td></td> <td>kVA</td> </tr> <tr> <td>Continuous 40°C</td> <td></td> <td>kW</td> </tr> <tr> <td></td> <td></td> <td>A</td> </tr> <tr> <td>Secours</td> <td></td> <td>kVA</td> </tr> <tr> <td>Std by</td> <td></td> <td>kW</td> </tr> <tr> <td>27°C</td> <td></td> <td>A</td> </tr> </table>	PUISSANCE / RATING			Tension Voltage		V	Connex.		Ph.	Continue		kVA	Continuous 40°C		kW			A	Secours		kVA	Std by		kW	27°C		A
LSA	Date																																																			
N°	Hz																																																			
Min-1/R.P.M.	Protection																																																			
Cos φ / P.F.	Cl. ther. / Th. class																																																			
Régulateur/A.V.R.																																																				
Altit. ≤	Masse / Weight																																																			
Rit AV/D.E bearing																																																				
Rit AR/N.D.E bearing																																																				
Graisse / Grease																																																				
Valeurs excit / Excit. values																																																				
en charge / full load																																																				
à vide / at no load																																																				
PUISSANCE / RATING																																																				
Tension Voltage		V																																																		
Connex.		Ph.																																																		
Continue		kVA																																																		
Continuous 40°C		kW																																																		
		A																																																		
Secours		kVA																																																		
Std by		kW																																																		
27°C		A																																																		
LR 0021 Conforme à C.E.I 34-1 (1994). According to I.E.C 34-1 (1994).																																																				
Made by Leroy Somer - 1 024 930/b																																																				

Voltage Regulation - AREP System with R438 AVR (42.2, 43.2, 44.2), R448 (46.2, 47.2)

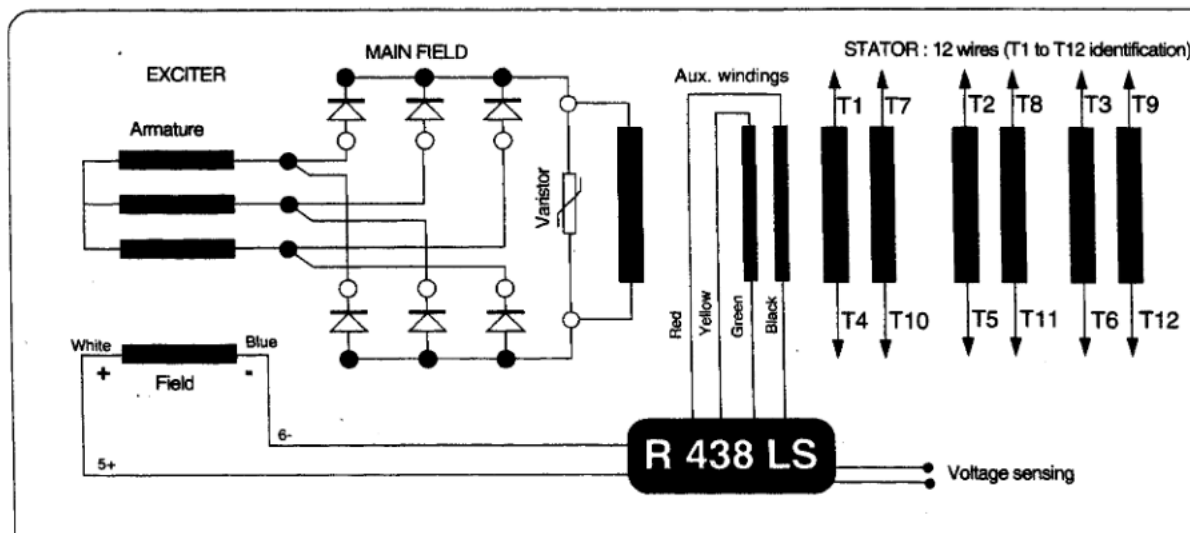

AREP Excitation System

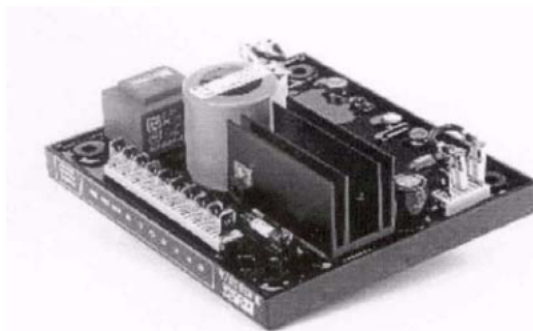

With AREP excitation, the R438 electronic AVR is powered by two auxiliary windings which are independent of the voltage sensing circuit. The first winding has a voltage in proportion to that of the alternator (shunt characteristic), the second has a voltage in proportion to the stator current (compound characteristic: booster effect). The power supply voltage is rectified and filtered before being used by the AVR monitoring transistor. This principle ensures that regulation is not affected by distortions generated by the load.

R 438 or R448 Regulator

- Short-circuit current = 3 x I_N for 10 seconds
- Standard power supply; 2 auxiliary windings
- Shunt power supply; max 150V -50/60 Hz
- Rated overload current: 8A-10S (R448: 10A-10S)
- Electronic protection (overload, short-circuit opening on voltage detection): excitation ceiling current for 10 seconds then return to approx. 1A

The alternator must be stopped (or the power switched off) in order to reset the protection.

- Fuse F1 on input side (X1, X2)
- Voltage detection: 5 VA isolated via transformer. 0-110V terminals = 95 to 140V, 0-220V terminals = 170 to 260V, 0-380V terminals = 340 to 520V
- Voltage regulation ± 1% (R448: ± 0.5%)
- Rapid or normal response time via strap ST2
- Voltage adjustment via potentiometer P2. Other voltages via step down transformer.
- Current detection: (parallel operation): C.T. 2.5VA cl1, secondary 1A (Option)
- Quadrature droop adjustment via potentiometer P1
- Underspeed protection (U/f) and LAM. Frequency threshold adjustable via potentiometer P4 on older models. Strap ST5 is connected for LAM operation. 25% or 13% voltage drop via strap ST10.
- Potentiometer P5, Max. excitation current adjustment via P5: 4.5 to 10A
- 50/60 Hz selection via strap ST3.

R438 A.V.R Options

- **Current transformer** for parallel operation.
- Remote voltage adjustment potentiometer: 470 OHMS, 0.5 W min: adjustment range + -5% (range limited via internal voltage potentiometer P2).
- Remove ST4 to connect the potentiometer. (A 1k potentiometer can also be used to extend the adjustment range).

R438 and R448

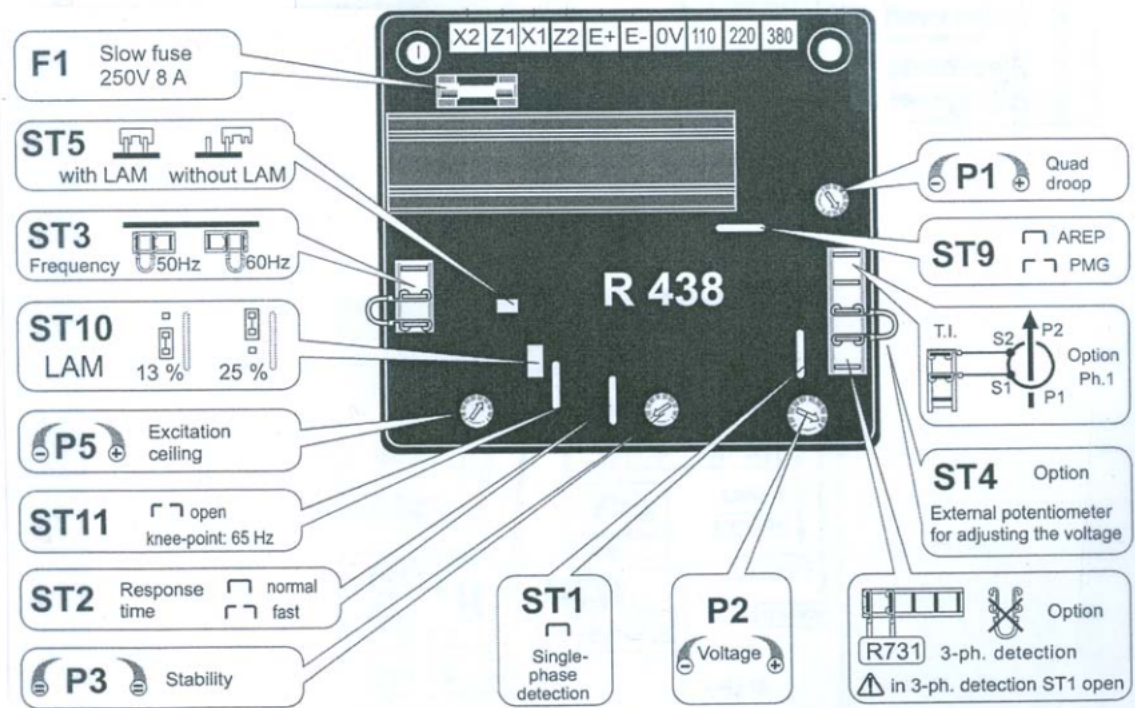

LAM Characteristics

The LAM system is integrated as standard in the R438 and R448 LS regulators.

Role of the "LAM" (Load Adjustment Module):

- On load impact, the rotation speed of the generator set decreases. When it passes below the preset frequency threshold, the "LAM" causes the voltage to drop by approximately 13% or 25% and consequently the amount of active load applied is reduced by approximately 25% to 50%, until the speed reaches its rated value again. Hence the "LAM" can be used either to reduce the speed variation (frequency) and its duration for a given applied load, or to increase the applied load possible for one speed variation (turbo-charged engine). To avoid voltage oscillations, the trip threshold for the "LAM" function should be set approximately 2 Hz below the lowest frequency in steady state.
- LAM: action eliminated by cutting strap ST5.

Older Model AVR

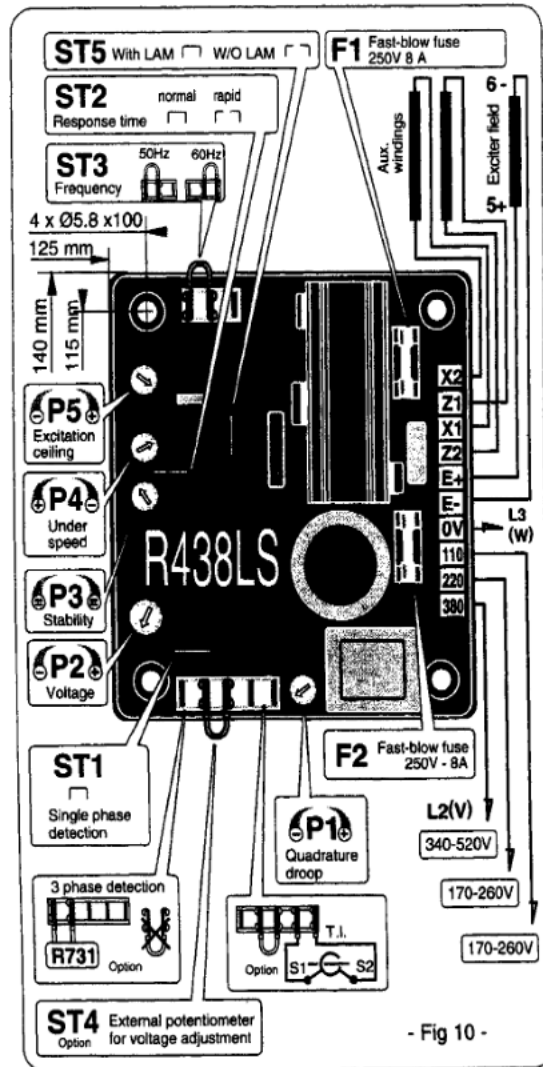

Older Model AVR

Typical effects of the "LAM" with a diesel engine (Figure 12).

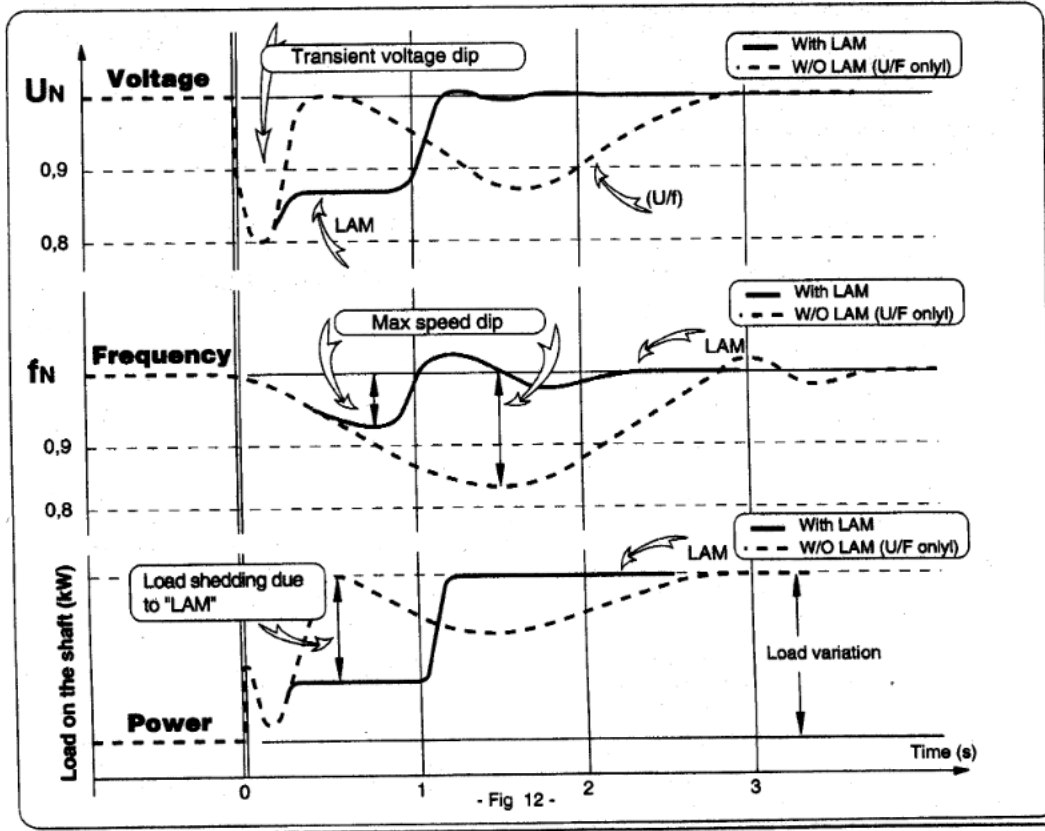

- Fig 12 -

INSTALLATION - COMMISSIONING

Assembly

All mechanical handing operations must be undertaken using approved equipment.

While being handled, the machine should remain horizontal (when travelling bar removed).

Handling

The generously sized lifting rings are for handling the alternator alone. They must not be used to lift the alternator alone. They must not be used to lift the genset. Choose a lifting system which respects the positioning of the rings (See Fig.13).

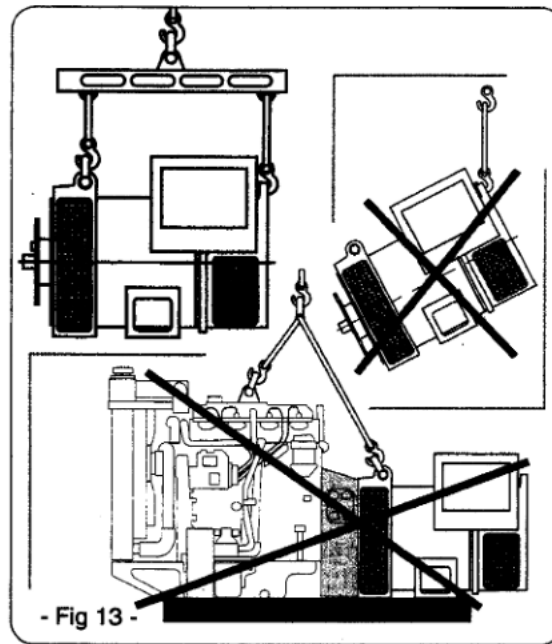

Coupling (Single Bearing Alternator)

Before coupling to the prime mover, check that both are compatible by:

- Undertaking a torsional analysis of the transmission.
- Checking the dimensions of the flywheel and its housing, the flange, coupling discs and offset.

⚠ WARNING

When coupling the alternator to the prime mover, the holes of the coupling discs should be aligned with the flywheel holes by cranking the engine.

Do not use the alternator fan to turn the rotor.

Tighten the coupling discs screws to the recommended torque and check that there is lateral play on the crankshaft.

Inspection Prior to First Use

Electrical checks



Under no circumstances should an alternator, new or otherwise, be operated if the isolation is less than 1 megohm for the stator and 100,000 ohms for the other windings.

There are three possible methods for restoring the above minimum values.

a) Dry out the machine for 24 hours in a drying oven at a temperature of approximately 110°C.
b) Blow hot air into the air input, having made sure that the machine is rotating with the exciter field disconnected.

c) Run in short-circuit mode (disconnect the AVR).

- Short-circuit the output phases using connections capable of supporting the rated current (try not to exceed 6 A/mm²).
- Insert a clamp ammeter to monitor the current passing through the short-circuit connections.
- Connect a 48 Volt battery in series with a rheostat of approximately 10 ohms (50 Watts), to the exciter field terminals, respecting the polarity.
- Connect a 48 Volt battery in series with a rheostat of approximately 10 ohms (50 Watts), to the exciter field terminals, respecting the polarity.
- Open fully all the alternator orifices.
- Run the alternator at rated speed. Adjust the exciter field current using the rheostat to obtain the rated output current in the short-circuit connections.

Note: Prolonged standstill: In order to avoid these problems, we recommend the use of space heaters, as well as turning over the machine from time to time.



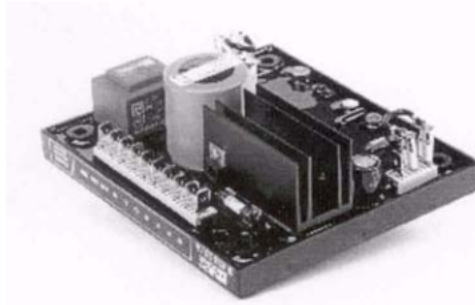

Space heaters are only really effective if they are working continuously while the machine is stopped.

R438 Adjustments (AREP System)

- a) Initial potentiometer settings (see table on following page).
 - remote voltage adjustment potentiometer: centre (ST4 strap removed)
- b) Install a D.C. analogue voltmeter (needle dial) cal. 50V on terminals E+, E- and an A.C. voltmeter cal. 300 - 500 or 1000V on the alternator output terminals.
- c) Make sure that the ST3 strap is positioned on the desired frequency (50 or 60 Hz).
- d) Voltage potentiometer P2 at minimum, fully to anti-clockwise (CCW).
- e) Turn the V/Hz potentiometer P4, fully to clockwise (if equipped with P4).
- f) Stability potentiometer P3 approximately 1/3 of travel anti-clockwise (CCW).
- g) Start the engine and set its speed to a frequency of 48 Hz for 50 Hz, or 58 for 60 Hz.
- h) Adjust the output voltage to the desired value using P2.
 - rated voltage UN for solo operation (eg. 400 V)
 - or UN + 2 to 4% for parallel operation with C.T. (eg. 410V -)

If the voltage oscillates, use P3 to make adjustments (try both directions) observing the voltage between E+ and E- (approx. 10V D.C.). The best response times are obtained at the limit of the instability. If no stable position can be obtained, try disconnecting or replacing the ST2 strap (normal/rapid).
- i) Check LAM operation: ST5 closed
- j) If AVR has P4, turn potentiometer P4 slowly anti-clockwise until there is a significant voltage drop (approx. 15 %).
- k) Vary the frequency (speed) of both parts between 48 or 58 Hz according to the operating frequency, and check the change in voltage previously observed (-15%).

I) Readjust the speed of the unit to its rated no-load value.

Action	Factory adjust.	Pot.
Voltage minimum fully CCW	400V - 50 Hz (0 - 380 V)	
Stability	Not adjusted (middle)	
Threshold/LAM or U/F Threshold for underspeed protection U/f and LAM function	ST3 on 50 Hz (factory=48 Hz) ST3 on 60 Hz (factory=58 Hz)	
Quadrature voltage droop (Parallel operation with C.T.) - No droop fully CCW	Not adjusted (fully CCW)	
 ceiling excitation current Excitation current and short circuit current limitation, minimum fully CCW	10 A maximum	

	ADJUSTMENT	SETTING
G25, G40, G60, G70, G80, G90, G125, G145, G185-R438 AREP		
1	ST 1 (Sensing jumper - single phase)	Not cut
2	ST2 (response Time jumper - normal)	Not cut
3	ST3 (Frequency - 60 Hz)	60 Hz Installed
4	ST4 (External potentiometer)	Ext pot wired per wiring diagram
5	ST5 (LAM jumper - with LAM)	Installed
7	ST9 (AREP)	Not cut
8	ST10 (Voltage drop amplitude jumper)	13% position (lower)
9	ST11 (Underfrequency knee point jumper - 58 Hz)	Not cut
10	P1 (Droop - 0%)	Fully counter-clockwise
11	P2 (Voltage)	Set to limit remote pot to 504V max output
12	P3 (Stability)	Center position
13	P5 (Excitation current - 10A maximum)	Fully clockwise
G240, G290, G450, G570 - R448 AREP		
1	ST 1 (Sensing jumper - single phase)	Not cut
2	ST2 (response Time jumper - normal)	Not cut
3	ST3 (Frequency - 60 Hz)	60 Hz Installed
4	ST4 (External potentiometer)	Ext pot wired per wiring diagram

5	ST5 (LAM jumper - with LAM)	Installed
6	ST6 (Alternator jumper - LSA 46.2.47.2)	Not cut
7	ST9 (AREP)	Not cut
8	ST10 (Voltage drop amplitude jumper)	13% position (lower)
9	ST11 (Underfrequency knee point jumper - 58 Hz)	Not cut
10	P1 (Droop - 0%)	Fully counter-clockwise
11	P2 (Voltage)	Set to limit remote pot to 504V max output (for 600V units set to 610V max output)
12	P3 (Stability)	Center position
13	P5 (Excitation current - 10A maximum)	Fully clockwise
G10 - R438 AREP		
G10 is same as G25-G185, except ST4 is with jumper (has no external potentiometer)		

SERVICING-MAINTENANCE

Safety Measures



Servicing or troubleshooting must be carried out strictly in accordance with instructions so as to avoid the risk of accidents and to maintain the machine in its original state.



All such operations performed on the alternator should be undertaken by personnel with training of electrical and mechanical components.

Before any intervention on the machine, ensure that it cannot be started by a manual or automatic system and that you have understood the operating principles of the system.

Checks after startup

After approximately 20 hours of operation, check that all fixing screws on the machine are still tight, plus the general state of the machine and the various electrical connections in the installation.

Cooling circuit

It is advisable to check that circulation of air is not reduced by partial blocking of the suction and discharge louvres: mud, fibre, grease, etc.

Bearings

The bearings are greased for life: approximate life of the grease (depending on use) = 20,000 hours or 3 years. Monitor the temperature rise in the bearings, which should not exceed 60°C above the ambient temperature. Should this value be exceeded, the machine must be stopped and checks carried out.

Electrical servicing

Cleaning product for the windings

WARNING

Do not use: Trichlorethylene, perchlorethylene, trichloroethane and any alkaline products.

Certain strictly defined pure volatile degreasing products can be used, such as:

- Normal petrol (without additives)
- Toluene (slightly toxic); flammable
- Benzene (or benzine, toxic); flammable
- Ciclohexane (non toxic); flammable

Cleaning the stator, rotor, exciter and diode bridge

The isolating components and the impregnation system are not at risk of damage from solvents (see the list of authorized products above).

Avoid letting the cleaning product run into the slots.

Apply the product with a brush, sponging frequently to avoid accumulation in the housing. Dry the winding with a dry cloth. Let any traces evaporate before reassembling the machine.

After cleaning the alternator it is essential to check the isolation of the windings.

Fault detection

If, when first commissioned, the alternator does not work normally, the source of the malfunction must be identified.

To do this, check that:

- the protective devices are fitted correctly
- all connections comply with the diagrams in the manuals supplied with the machine
- the speed of the unit is correct. Repeat the operations instructions.

Mechanical Servicing **CAUTION**

Cleaning the machine using a water spray or a high-pressure washer is strictly prohibited. Any problems arising from such treatment are not covered by our warranty.

The machine should be cleaned with a degreasing agent, applied using a brush. Check that the degreasing agent will not affect the paint. Compressed air should be used to remove any dust. If filters have been added to the machine after manufacturer and do not have thermal protection, the service personnel should clean the air filters periodically and systematically, as often as necessary (everyday in very dusty atmospheres). Cleaning can be performed using water for dry dust or in a bath containing soap or detergent in the case of greasy dust. Petrol or chloroethylene can also be used. After cleaning the alternator, it is essential to check the winding insulation.

Mechanical Defects

Mechanical defects	
Bearing Defect	Action
Excessive overheating of one or both bearings (temp of bearings over 80°C) (With or without abnormal bearing noise)	If the bearing has turned blue or if the grease has turned black, change the bearing.
	Bearing race badly locked (moving in its housing)
Overheating	Action
Excessive overheating of alternator frame (temperature rise of more than 40°C above ambient)	Air flow (inlet-outlet) partially clogged or hot air is being recycled either from alternator or prime mover.
	Alternator is functioning at too high a voltage (over 105% of rated voltage on load).
	Alternator overloaded
Vibration Problem	Action
Too much vibration	Misalignment (coupling)
	Defective mounting or play in coupling
	Incorrect balancing of shaft (Engine-Alternator)
Excessive vibration and humming noise coming from the alternator	Three phase alternator is single phase loaded in excess of acceptable level.
	Short circuit in the alternator stator
Abnormal Noises	Action
Alternator damaged by a significant impact which is followed by humming and vibration	System short circuit
	MIS paralleling
	Possible consequences (according to the seriousness of the above faults):
	Broken or damaged coupling
	Broken or bent shaft end
	Shifting and short circuit of main field rotor
	Fractured fan or coming loose on shaft
Blown rotating diodes, or and A.V.R	

Electrical Faults

Fault	Action	Symptoms	Cause
No voltage at no load or startup	Connect a battery of 4 to 12 volts to terminals E+ or E- respecting the polarity on the A.V.R. for 2 to 3 seconds	- The alternator builds up and voltage is correct when the battery is removed.	- Lack of residual magnetism
		The alternator builds up but voltage does not reach nominal value when the battery is removed.	- Check the connections of the sending leads to the A.V.R. - Faulty rotating diode - Short-circuit on rotor windings
		The alternator builds up but voltage collapses when the battery is removed.	- Faulty A.V.R. - Exciter field short-circuited or open circuit (check windings) - Main field winding open circuit (check resistance).
Voltage too low	Check the prime mover speed	Correct speed	- Check A.V.R. connections (possible AVR failure) - Exciter field short-circuited - Rotating diode(s) burnt out. - Main field rotor short-circuited - Check the resistance.
		Speed too low	Increase the speed of primer mover. (Do not touch the AVR voltage pot. (P2) before running at the correct speed).
Voltage too high	Adjust potentiometer voltage	No adjustment of voltage, measure voltage E +/E- on AVR	Voltage between E+ and E- > 12V or AVR faulty
Voltage oscillations	Adjust the stability potentiometer on A.V.R	If no effect: change recovery mode normal/rapid (ST2) R438 or R448 only	Check speed for possible cyclic irregularity Loose connections Faulty A.V.R. Speed below nominal on load (or LAM set too high)
Voltage correct on no load too low on load (*)	Run on no-load and check voltage between E+ and E-	Voltage between E+ and E- <6V (DC) Voltage between E+ and E- >10V (DC)	Check speed (or LAM on R438 set too high) Faulty rotating diodes faulty Short circuit in the main field. Check resistance. Faulty exciter armature. Check resistance.
Voltage collapses during normal operation (**)	Check the AVR, the surge suppressor, the rotating diodes and replace any defective part	The output voltage does not return the rated value	Exciter winding open circuit Faulty exciter armature Faulty AVR Main field rotor winding open circuit or short circuit

 **WARNING**

***During single-phase operation, check that the sensing wires from the AVR are connected to the correct output terminals.**

 **WARNING**

**** The AVR internal protection may cut in (overload lost connection, short circuit).**

Checking the winding

You can check the winding insulation by performing a high voltage test. In this case you must disconnect all AVR wires.

During this procedure, make sure that the alternator is disconnected from any external load and inspect the terminal box to check that the connections are fully tightened.

- Stop the unit, disconnect and disconnect the leads E+ (5+) and E- (6-) from the terminals located on the side of the voltage regulator (AVR).
- Using jumper wires and a momentary normally open switch, connect the E+ (5+) lead to one side of the switch and connect the other side of the switch to the positive (+) terminal of a 6 VDC dry cell battery. Then take the E- (6-) lead and ground it to the frame of the unit, and ground the negative (-) terminal of the battery to the unit.
- Run the unit at its rated speed.
- Connect a voltmeter to the direct hookups and shut the output breaker and the momentarily shut switch connected to the E+ (5+) lead and check the output voltage on the voltmeter. If the output voltage of the alternator is greater than its normal value then the machine is in good working order. The fault therefore comes from the AVR or its associated wiring(i.e. sensing, auxiliary windings).

Checking the diode bridge



Damage caused to the AVR in such conditions is not covered by our warranty.

LSA 42.2 diode bridge

Anode **A**  **C** Cathode

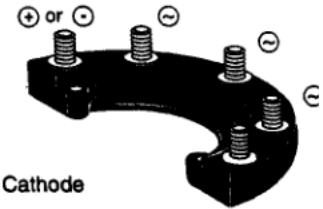
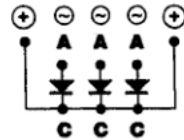
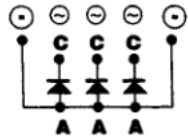

A diode in good condition enables the current to flow in only one direction from Anode to Cathode

- Fig21 -

LSA 43.2 / 44.2 Diode bridge

Anode **A**  **C** Cathode

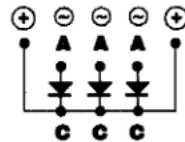
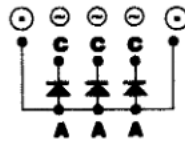

A diode in good working condition allows the current to flow in only one direction, from anode to cathode.

A diode in good working condition allows the current to flow in only one direction, from anode to cathode.

TECHNICAL CHARACTERISTICS

Electrical Characteristics

The PARTNER alternator is a machine without slip rings and revolving field brushes, wound as "2/3 pitch"; 12-wire, with class H insulation and a field excitation system available in either "SHUNT" or 'AREP" version. Interference suppression conforms with standard EN 55011, group 1, Class B.

Options: Stator temperature detection probes, space heaters.

Mechanical Characteristics

- Steel Frame
- End shields in cast iron or aluminium
- Ball bearings greased for life
- Mounting arrangement
- MD 35 STANDARD: single bearing, with standard feet and SAE coupling discs
- B 34 STANDARD: two bearing feet mounted with standard bare shaft key wayed
- Drip-proof machine, self-cooled
- Degree of protection: IP 23

Options-Air input filter, air output labyrinth cowling

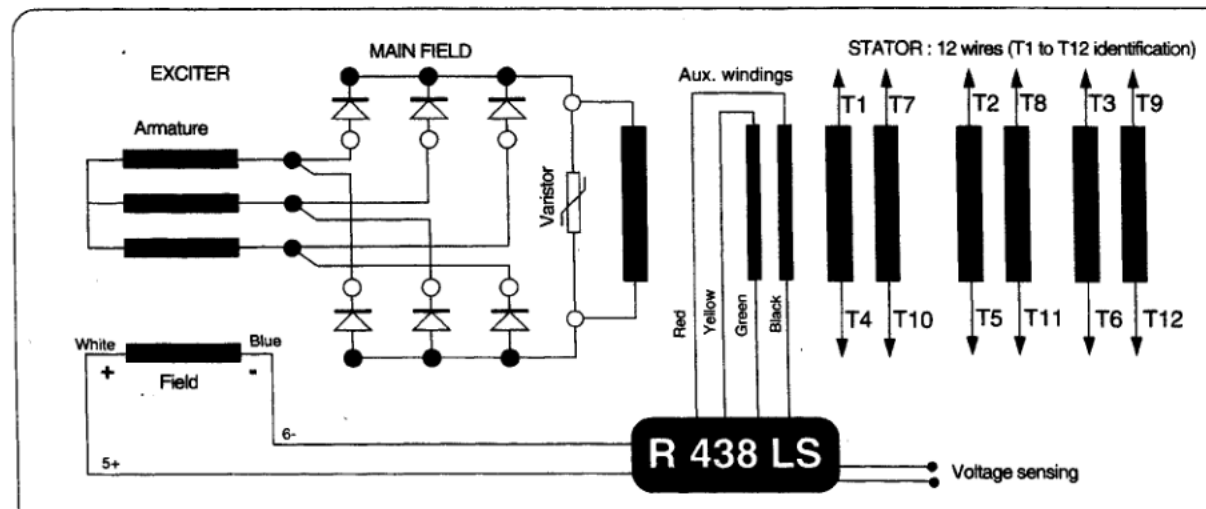

AREP Field Excitation System

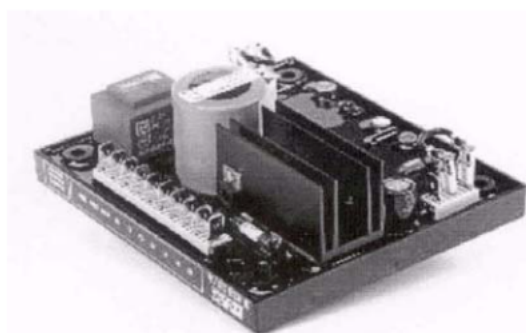

With AREP excitation, the R438/448 electronic AVR is powered by two auxiliary windings which are independent of the voltage sensing circuit. The first winding has a voltage in proportion to that of the alternator (shunt characteristic), the second has a voltage in proportion to the stator current (compound characteristic: booster effect). The power supply voltage is rectified and filtered before being used by the AVR monitoring transistor. This principle ensures that regulation is not affected by distortions generated by the load.

R 438/448 LS Regulator

- Short-circuit current = 3 x I_N for 10 seconds
- Standard power supply; 2 auxiliary windings
- Shunt power supply; max 150V -50/60 Hz
- Rated overload current: 8A-10S (R448: 10A - 10S)
- Electronic protection (overload, short-circuit opening on voltage detection): excitation ceiling current for 10 seconds then return to approx. 1A

The alternator must be stopped (or the power switched off) in order to reset the protection.

- Fuse F1 on input side (X1, X2)
- Voltage detection: 5 VA isolated via transformer. 0-110V terminals = 95 to 140V, 0-220V terminals = 170 to 260V, 0-380V terminals = 340 to 520V
- Voltage regulation $\pm 1\%$ (R448: $\pm 0.5\%$)
- Rapid or normal response time via strap ST2
- Voltage adjustment via potentiometer P2. Other voltages via step down transformer.
- Current detection: (parallel operation): C.T. 2.5VA cl1, secondary 1A (Option)
- Quadrature droop adjustment via potentiometer P1
- Underspeed protection (U/f) and LAM. Frequency threshold adjustable via potentiometer P4 on older models. Strap ST5 is connected for LAM operation, 25% or 13% voltage drop via strap ST10.
- Max. excitation current adjustment via P5: 4.5 to 10A
- 50/60 Hz selection via strap ST3.

R438 A.V.R Options

- Current transformer for parallel operation.
- Remote voltage adjustment potentiometer: 470 Q, 0.5 W min: adjustment range :t 5% (range limited via internal voltage potentiometer P2). Remove ST4 to connect the potentiometer. (A 1 k potentiometer can also be used to extend the adjustment range.)

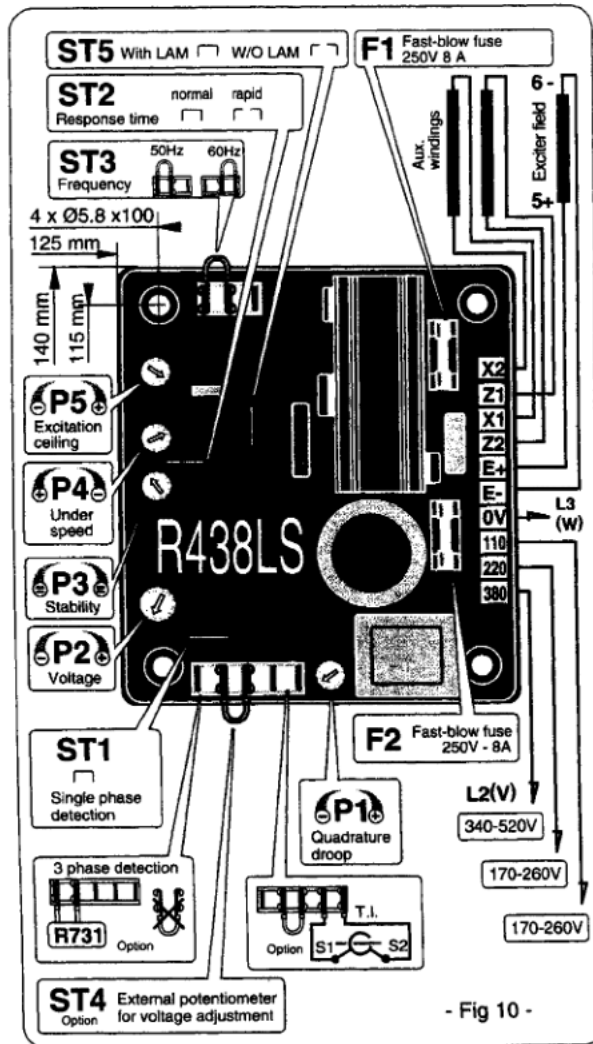

LAM Characteristics

The LAM system is integrated as standard in the R438/448 LS regulator.

Role of the "LAM" (Load Adjustment Module):

- On load impact, the rotation speed of the generator set decreases. When it passes below the preset frequency threshold, the "LAM" causes the voltage to drop by approximately 13% or 25% and consequently the amount of active load applied is reduced by approximately 25% to 50%, until the speed reaches its rated value again. Hence the "LAM" can be used either to reduce the speed variation (frequency) and its duration for a given applied load, or to increase the applied load possible for one speed variation (turbo-charged engine). To avoid voltage oscillations, the trip threshold for the "LAM" function should be set approximately 2 Hz below the lowest frequency in steady state.
- LAM: action eliminated by cutting strap ST5.

Typical effects of the "LAM" with a diesel engine (Figure 12).

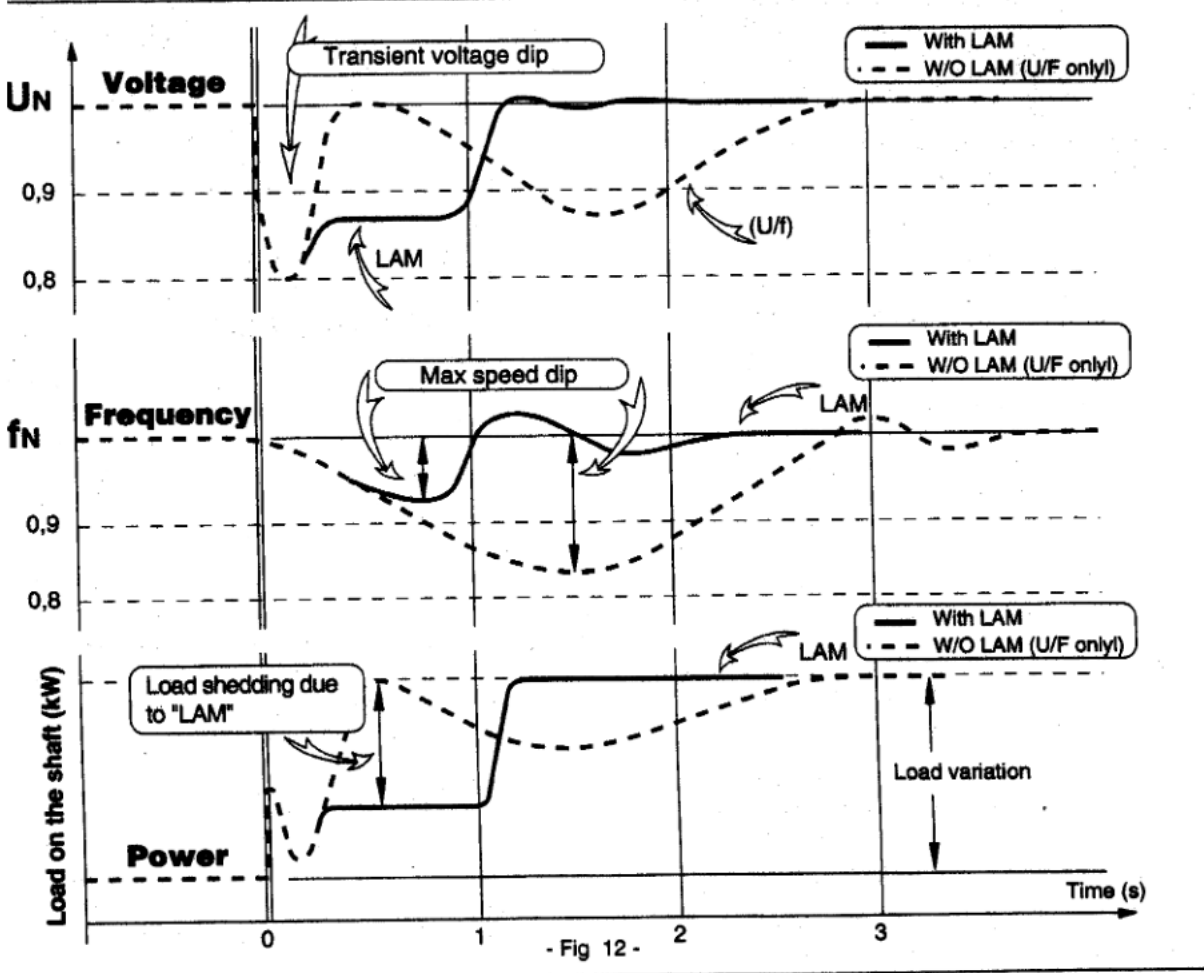

Dismantling reassembly



During the warranty period, this operation should only be carried out in a LEROY SOMER approved workshop or in our factory, otherwise the warranty may be invalidated.

The machine must be horizontal when handled (when travelling bar removed). See fig 23.

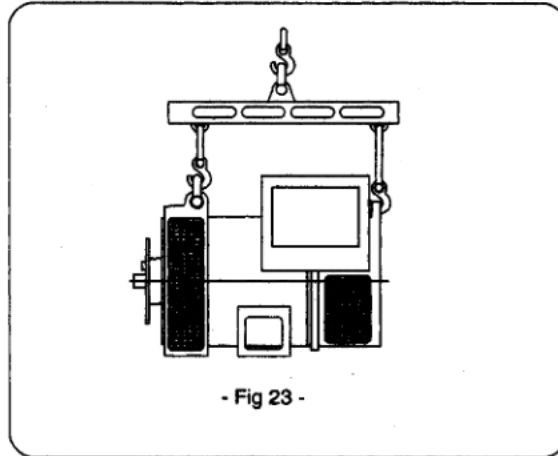

Tools Required

To fully dismantle the machine, we recommend you have the tools listed below:

1. Ratchet spanner + extension
2. Torque wrench
3. 7 mm flat spanner
4. 8 mm flat spanner
5. 10 mm flat spanner
6. 12 mm flat spanner
7. 8 mm socket
8. 10 mm socket
9. 13 mm socket
10. 15 mm Allen key (eg. Facom: ET5)
11. 16 mm Allen key (ego Facom: ET6)
12. TORX T20 bit
13. TORX T30 bit
14. Puller (eg. Facom: U35)
15. Puller (eg. Facom: U32/350)

Screw tightening torque

Identification	Screw Ø	Torque N•m
Field term. block screw	M4	4
Field screw	M6	10
Diode bridge screw	M6	5
Diode nut	M5	4
Assembly rod	M8	20
Earthing screw	M6	5
Balancing bolt	M5	4
Disc/shaft screw	M10	66
Lifting screw	M8	4
Louvre screw	M6	5
Cover screw	M6	5

Accessing connections and the regulation system

The terminals are accessed by removing the terminal box lid.

To access the adjustment potentiometers on the AVR, the side plate should be removed.

Accessing, checking and replacing diodes

Dismantling

- Remove the terminal box lid].
- Remove the air intake louvre.
- Unscrew the fixing clamps on the power output cables, disconnect E+ . E- on the exciter and R 791 module.
- Remove the 4 nuts on the tie rods.
- Remove the NDE bracket using an extractor: eg. U.32 -350 (FACOM).
- Remove the surge suppressor.
- Remove the 4 fixing screws from the diode bridges on the armature.
- Disconnect the diodes.
- Check the 6 diodes using either an ohmmeter or a battery lamp.

Reassembly

- Replace the diodes, respecting the polarity.
- Replace the surge suppressor.
- Insert a new O ring in the bearing housing.
- Refit the NDE bracket (see fig 24) and pass the bundle of wires between the top bars of the flange.
- Replace the fixing clamps on the cables and the R791 module.
- Refit the air intake louvre.
- Replace the terminal box lid.

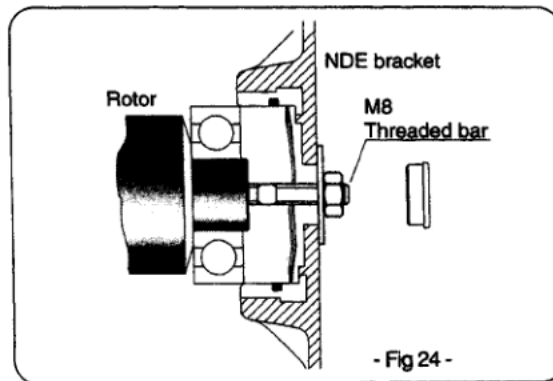
**Replacing the NDE bearing on a single-bearing machine****Dismantling**

Dismantle the NDE bracket and remove the bearing using a puller. (See Fig 25).

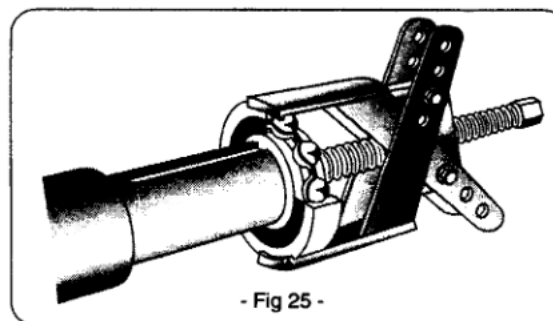
**Reassembly**

- Heat the inner slipping of a new bearing by induction or in a drying oven at 80 °C (do not use an oil bath) and fit it to the machine.
- Place the preloading wavy washer in the flange and fit a new O ring seal.
- Replace the NDE bracket.
- Rest the rotor on one of its poles, then slide it out. Use the tube as a lever arm to assist dismantling.

-After extraction, be careful with the fan. It is necessary to replace the fan in case of disassembling.

NOTE: If intervention is required on the main field (rewinding, replacement of components), the rotor assembly must be rebalanced.

Reassembly

-Follow the dismantling procedure in reverse order. Take care not to knock the windings when refitting the rotor in the stator.

-If you replace the fan, respect the assembly guide (fig 27). Use a tube and a screw.

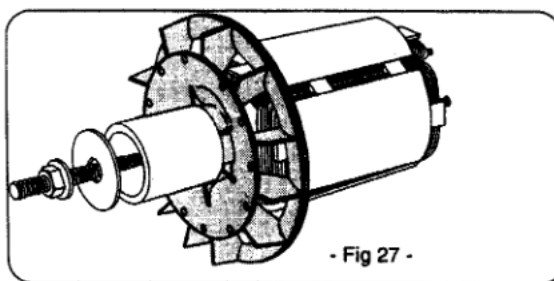

Follow the procedure for reassembling the bearings.



After final adjustments, the access panels or cover should be refitted.

Electrical characteristics table

Alternator - 2/4 - pole - 50/60 Hz - No. 6 standard winding. (400V for the excitation values).

The voltage and current values are given for no-load operation and operation at rated load with separate field excitation. All values are given at ± 10% (for exact values, consult the test report) and are subject to change without prior warning.

Alternator 4 pole with AREP excitation Resistances at 20°C () -50/60 Hz

Type 42.2	VS2*	S4	S5	M6	M7	L9
L/N stator	0,76	0,34	0,34	0,22	0,22	0,2
Rotor	2,1	2,7	2,7	3,3	3,3	3,7
Auxil.wind. X1, X2	0,5	0,3	0,3	0,26	0,26	0,23
Auxil.wind Z1,Z2	0,6	0,5	0,5	0,44	0,44	0,41
Field	6	6	6	6	6	6
Armature	0,5	0,51	0,51	0,51	0,51	0,51

Alternator 4 pole with AREP excitation

Field excitation current (i exc (A) -400V -50Hz)

Symbols: "i exc". excitation current of the exciter field.

Type 42.2	VS2*	S4	S5	M6	M7	L9
No-load	0,9	0,9	0,9	0,8	0,8	0,7
At rated load	2,4	2,1	2,3	2	2,3	2,3

(* Lister type machine

For 60Hz machines the "i exc" values are approximately 5 to 10% less.

Resistances at 20 °C (Ω)

LSA 43.2	Stator L/N	Rotor	Wind. X1,X2	Widing. Z1,Z2	Field	Armat.
S1	0,155	1,35	0,32	0,52	4,6	0,23
S15	0,155	1,35	0,32	0,52	4,6	0,23
S25	0,155	1,35	0,32	0,52	4,6	0,23
S35	0,128	1,41	0,29	0,5	4,6	0,23
M45	0,105	1,57	0,26	0,51	4,6	0,23
L65	0,083	1,76	0,26	0,44	4,6	0,23
L8	0,063	1,96	0,21	0,4	4,6	0,23

Field excitation current *i* exc (A) -400 V -50 Hz

"i exc": excitation current of the exciter field

LSA 43.2	no load	on load
S1	1	2,6
S15	1	3
S25	1	3,2
S35	1	3,6
M45	0,8	3,2
L65	0,8	3,2
L8	0,8	3,2

Resistances at 20 °C (Ω)

LSA 44.2	Stator L/N	Rotor	Wind. X1,X2	Wind. Z1,Z2	Field	Armat.
VS3	0,046	2,51	0,3	0,5	4,9	0,5
VS45	0,046	2,51	0,3	0,5	4,9	0,5
S7	0,036	2,91	0,21	0,32	4,9	0,5
S75	0,036	2,91	0,21	0,32	4,9	0,5
M95	0,024	3,32	0,17	0,28	4,9	0,5
L12	0,019	3,66	0,16	0,21	4,9	0,5

Field excitation current *i* exc (A) -400 V -50 Hz

"i exc": excitation current of the exciter field

LSA 44.2	no load	on load
VS3	1	3,6
VS45	1	4,2
S7	1	3,8
S75	1	4,2
M95	1,2	4
L12	1	3,8

Revision History

Rev Level	EC Number	Comments
A		Original Release
B		Revisions
C		Revisions
D		Revisions
E		Revisions
F		Revisions
G		12-09 Revisions
H	SVC31253	8-2-2010 Revisions



Doosan Infracore
Portable Power

Doosan Infracore Portable Power
1293 Glenway Drive
Statesville, N.C. 28625
www.doosanportablepower.com

