



INSTALLATION AND SERVICE MANUAL



ShuttleTrack

Agency Approvals

Medical Electrical Equipment

With respect to electric shock, fire
and mechanical hazards only

In accordance with

AAMI ES60601-1: Issued 2005 +A1

CSA C22.2.60601-1: Issued 2014 Ed: 3

EN60601-1: Issued 2006 +C1; A11; A1

IEC60601-1-6: Issued 2010 Ed: 3 + A

IEC62366: Issued 2007 Ed: 1 + A1

IEC60601-2-41: Issued 2009 Ed: 2 + A1

Electromagnetic compatibility for immunity
and emissions in accordance with

EN60601-1-2(2001) Class B and CISPR 11 Ed: 5.1 (with a1:2010) Class A

Classifications:

1. Protection against electrical shock (5.1, 5.2). Class I permanently connected,
2. Protection against harmful ingress of water (5.3). None.
3. Degree of safety in the presence of flammable anesthetics or oxygen (5.5). Not suitable for use in the presence of flammable anesthetics or oxygen.
4. Mode of operation (5.6). Continuous

Intended use: The ShuttleTrack System facilitates up to 69” of horizontal travel for Procedural Medical Lighting for Hospital, Clinic, Veterinary, Minor Surgery, Examination or Diagnosis, within suitable facilities designated for such purposes.

User interface: The ShuttleTrack system is for minor surgery, procedural and examination lights and is intended to be used by medical professionals.

Misuses: For any purpose or use at any facility other than stated above. Caution shall be exercised when positioning the light head and avoid contact or collision with the patient, other medical professionals or other lights/equipment.

TABLE OF CONTENTS

Section 1: General Information	5
Definition of Terms	5
List of Symbols	5
Limited Warranty	Error! Bookmark not defined.
Disposal of Waste	7
Section 2: Light Specifications	8
Section 3: Installation/Assembly	9
Ceiling Calculation for the ShuttleTrack	9
Ceiling Mount Pre-Installation Guidelines	10
Ceiling Structure Construction and Mounting	11
Disassembly of the Track Mount Before Installation	13
Track Mount Installation Procedure	18
Installing the Arm Assembly	21
Section 4: Operating Instructions	22
Power Failures	22
Positioning the Light Head	22
Section 5: Safety and Maintenance Instructions	23
Safety Tips	23
Maintenance	24
Fuse Replacement	24
LED Maintenance	24
Spring Tension Adjustment Tool	25
Adjusting the Articulating Arm	26
Cleaning Instructions	27
Maintenance Schedule	28
Component/Assembly Part Numbers	28
Section 6: Troubleshooting	29
General Troubleshooting	29

Table of Figures

Figure 1: Single Trolley ShuttleTrack.....	9
Figure 2: Mounting Methods for the ShuttleTrack.....	11
Figure 2: Mounting Hole Pattern for the ShuttleTrack.....	12
Figure 4: Removing the End Plate	13
Figure 5: Removing the Side Panels	14
Figure 6: Removing the Dress Covers.....	15
Figure 7: Removing the Stop Pins	16
Figure 8: Removing the Trolley.....	17
Figure 9: The Trolley Assembly	19
Figure 10: The Carrier Chain	20
Figure 11: Installing the Light Head	21
Figure 12: Spring Tension Adjustment Tool.....	25
Figure 13: Adjusting the Articulating Arm.....	26

Section 1: General Information

Definition of Terms

I.E.C. International Electrotechnical Commission

Medical Electrical Equipment

Electrical equipment intended to diagnose, treat the patient under medical supervision.

Arm Assembly – Extension/Articulating Arm

The Extension Arm is the horizontal positioning arm with a pivot that increases the area covered by the Articulating Arm and yoke/light head assembly. The Articulating Arm allows for vertical positioning of the light head.

Head/Yoke Assembly

This assembly includes the light head (light source) and provides for the light head rotation (positioning).

Sterilizable Handle

An easily removable device that when properly sterilized maintains a sterile area in order to handle it under aseptic conditions when attached to the equipment.

Off Center Moment

The unit of measurement for torque which is caused by an off-center load. This is measured in foot-pounds.

Protective earth ground

The conductor used to connect the non-current-carrying metal parts of equipment, raceways, and other enclosures to the system grounded conductor, the grounding electrode conductor, or both, of the circuit at the service equipment or at the source of a separately derived system.





Neutral Conductor (common)

In an AC circuit, the return line for current.

Means of Isolation

The Means of Isolation, disconnects (Isolates) the light from the source of power. This isolation makes it safe to work on the light. In the case of a ceiling mounted light, the means of isolation is the circuit breaker that supplies the power to the circuit. In the case of the Wall, floor or Floor UPS, the means of isolation is the cord. Unplugging the cord isolates the light from power.

List of Symbols

	Read accompanying documents		Neutral conductor
	Fuse marking		Caution
	Electric shock hazard		

**Medical Illumination International, Inc.
Limited Warranty**

This document comprises the general terms of your product's Limited Warranty. This Limited Warranty is applicable to products sold by Medical Illumination International, Inc. or one of its subsidiaries or divisions (collectively, "MI") through one of MI's authorized dealers, distributors or sales representatives (an "Authorized Dealer"). This Limited Warranty is not applicable to any MI product not purchased from an Authorized Dealer. This Limited Warranty extends only to the first retail purchaser of a product and is not transferable or assignable.

Your product is warranted against defective material and/or workmanship, excluding normal replacement parts, for a period of three (3) years from the date of shipment. Normal replacement parts include, but are not limited to, bulbs, sterilizable handles, filters and glass items. This Limited Warranty applies exclusively to the repair or replacement of parts recognized as defective by MI that are in normal use and have not been modified or repaired by unauthorized personnel.

This Limited Warranty is in lieu of all other warranties, expressed or implied, including any implied warranty of fitness for a particular purpose and all other obligations or liabilities, including liability for incidental, special or consequential damages or labor.

In the event of a defect or failure covered under this Limited Warranty, please contact MI immediately by phone (818/838-3025), fax (818/838-3725), email (info@medillum.com) or through our website (<http://www.medillum.com>). Be prepared to give the model number, serial number and full description of the issue. This Limited Warranty will not apply if the MI serial number affixed to the product has been removed, obliterated or defaced.

Our Customer Service department will attempt to solve the problem over the phone. If it becomes necessary, we will determine, in our sole discretion, the best way to address the issue. We may require that the product be sent to our factory for repair. In limited instances, we may dispatch an authorized service technician. No product serviced by other than our authorized service technician will be covered by this Limited Warranty.

In the event we determine that your product needs to be repaired, either onsite or by return to our factory, please do not continue to use your product. MI is not responsible for any costs, expenses, losses or damage resulting from your continued use of the product prior to its authorized repair. MI is not responsible for costs or expenses incurred for loss of use of the product.

If we require the return of the product to our factory, you will be provided with a Return Authorization number. Products sent to the factory without a Return Authorization number will not be accepted. It is your obligation to arrange for return shipment of your product to the factory for warranty service, which shall be at your expense. Your Product must be returned to our factory within thirty (30) days of the date of the Return Authorization. Carefully package the product and return it, freight prepaid and insured, with the Return Authorization number clearly marked on the outside of the box, to Medical Illumination International, Inc., 19749 Dearborn Street, Chatsworth, CA 91311, RA# _____.

Damage resulting from inadequate packing is not covered by this warranty, and shipping insurance does not cover damage due to inadequate packing. MI cannot be held responsible for in-transit loss or damage. In the event that freight-related damage should occur, we will notify you immediately so that you can file a damage claim with the freight carrier.

Within the warranty period, MI will evaluate your returned product, repair as appropriate, and ship the product back to you with freight costs prepaid by MI. In the event that damage or failure is discovered that is not covered by this Limited Warranty, we will contact you for your approval of all costs that may be incurred prior to commencing any repairs.

This Limited Warranty does not cover the following:

- Any field labor or outside services, including, but not limited to, electricians, contractors, installation services, routine maintenance or other repair services.

- Damage to the product resulting from tampering, accident, abuse, negligence, alteration or other causes unrelated to problems with material and/or workmanship.
- Damage due to improper installation, use, cleaning or maintenance, as outlined in the Installation and Service Manual.
- Labor costs associated with removing, re-packaging for shipment or reinstalling product

Limited Warranty, Rev 8-23

Disposal of Waste

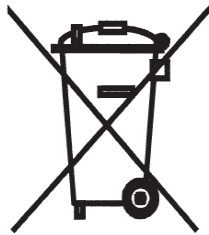

This product must not be disposed of with your other waste. Instead, it is your responsibility to dispose of your waste equipment by handing it over to a designated collection point for the recycling of waste electrical and electronic equipment, or by returning it to Medical Illumination International, Inc for reprocessing. The separate collection and recycling of your waste equipment at the time of disposal will help to conserve natural resources and ensure that it is recycled in a manner that protects human health and the environment. For more information about where you can drop off your waste equipment for recycling, please contact your local city office, your waste disposal service, or your product distributor or retailer.

Section 2: Light Specifications

Optical Specification			
Parameter	MI-1000	MI-750	MI-550
# of LED's	36	18	8
Output	100,000 Lux @ 39.4" (1m)	75,000 Lux @ 39.4" (1m)	55,000 Lux @ 24" (0.6m)
CCT	4,300°K		
CRI	97		
Focal Length	39.4" (1m)		24" (0.6m)
Dimming Levels	5	3	2
Dimming Percentages	100%, 87%, 75%, 62%, 50%	100%, 75%, 50%	100%, 50%
Endo Mode	Yes	No	No
Light Field (d10)	≈Ø8.3" (Ø209mm)	≈Ø7.7" (Ø196mm)	≈Ø6.0" (Ø152mm)
Light Field (d50)	≈Ø4.9" (Ø124mm)	≈Ø4.3" (Ø110mm)	≈Ø3.5" (Ø 89mm)
Depth of Illumination	24.0" (610mm)	26.5" (673mm)	-
Irradiance	295 W/m ²	196 W/m ²	71 W/m ²
Electrical Specifications			
Supply Circuit	100 - 240 VAC, 50/60Hz		
Fuse Rating	2.5 Amp/250VAC	1.5 Amp/250VAC	1.5 Amp/250VAC
Power Supply power handling capacity	100W	65W	65W
Light Head power consumption	54W @24VDC	27W @24VDC	16W @24VDC
Mechanical Specifications			
Track Length	70" (1,778)		
Track Width	7.75" (197)		
Light Head Weight	14.6 lbs (6.6 kg)	9.0 lbs (4.1 kg)	6.9 lbs (3.1 kg)
Light Head Dimensions	Ø18" (Ø457mm) 4" H (102mm)	Ø14.5" (368mm) 3.25" H (83mm)	Ø9.2" (234mm) 2.6" (66mm)
Arm Assembly Weight	Single: 48.3 lbs (21.9 kg)		
Articulating Arm Vertical Movement	+20° Up, -60° Down		
Articulating Arm Horizontal Movement	≈540°		
Articulating Arm/Yoke Interface	≈540°		
Yoke/Light Head Interface	≈300°		
Environmental Specifications			
Ambient/Operating temperature	41°F to 104°F (5°C to 40°C)		
Storage temperature	-4°F to 122°F (-20°C to 50°C)		
Humidity	10 - 90% Relative Humidity		
Pressure	100kPA (@<2k meters)		

Section 3: Installation/Assembly

Ceiling Calculation for the ShuttleTrack

Use the following table to select the correct length Down-Tube for your application

Ceiling Mounting Height "Y"-Value	Down-Tube Length	"X"-Value	Head room to bottom of Extension Arm (Y-Value - X-Value)
8'0" – 9'0" [2438 – 2743]	9" [229] P/N: 1001461-9ST	24.25" [616]	71.75" – 83.75" [1822 – 2127]
9'1" – 10'0" [2768 – 3048]	20" [508] P/N: 1001461-20ST	35.25" [895]	72.75" – 84.75" [1848 – 2153]

[xx] denotes millimeters

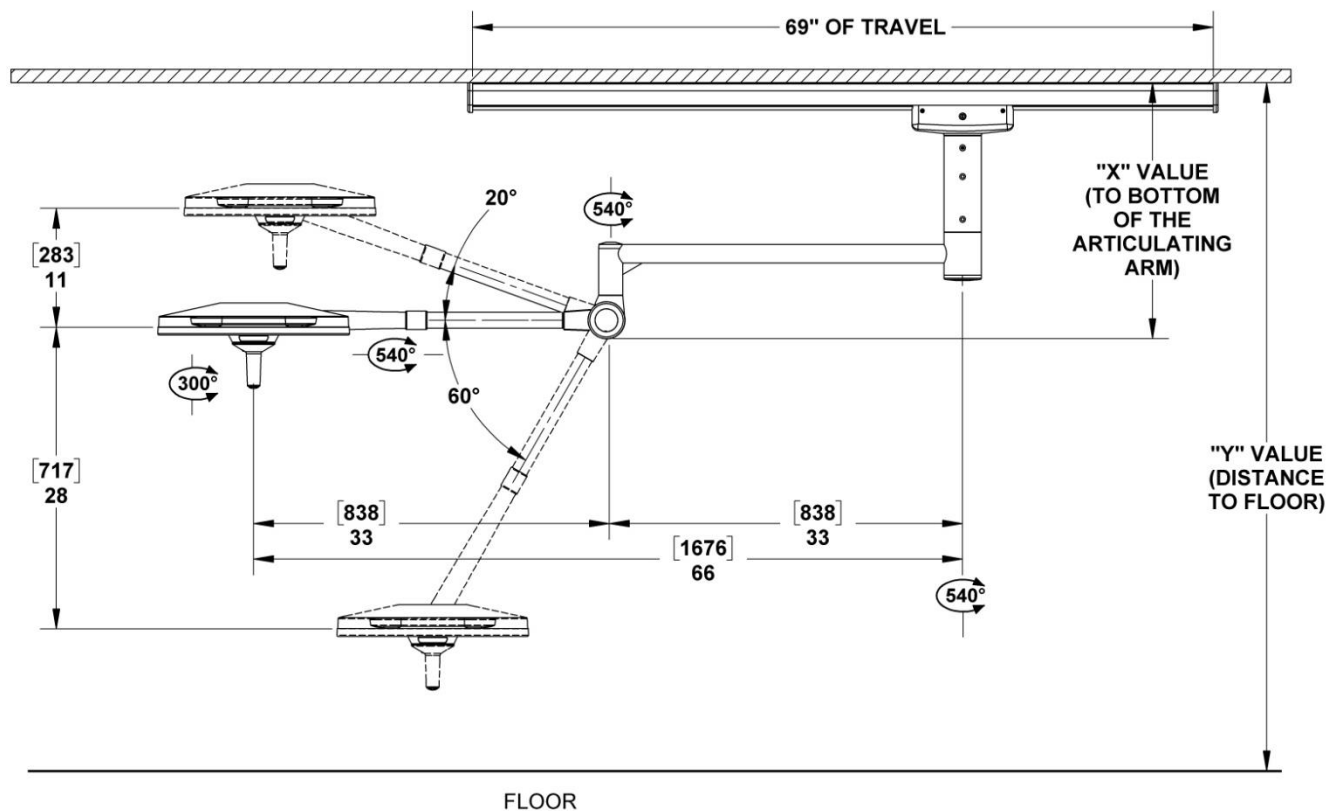

Figure 1: Single Trolley ShuttleTrack

Ceiling Mount Pre-Installation Guidelines

SPECIAL NOTE: Installation and repair of this equipment should be performed by qualified persons only. Medical Illumination International, Inc. does not warranty any damage occurring as a result of improper installation. It is recommended that this installation manual be completely reviewed prior to installation.

Before installation, check to ensure the following minimum conditions are provided:

Type	Weight: Lb	Moment: Ft Lb
Single Trolley	145	326
Dual Trolley	231	626

← recommended

Medical Illumination strongly recommends that the ceiling structure be designed to the weights and moments for the worst case (Dual Trolley). Designing for the heaviest model with the highest load/torque will ensure adequate support for all models.



A structural mount that does not meet these minimum conditions can cause serious injury and/or property damage.



A sloped or vaulted ceiling will require a level mounting surface be constructed that meets the above listed requirements.

- The ceiling structure must be strong enough to support the weight and rigid enough to constrain rotation to less than 0.1° at the track base.
- The equipment may be mounted directly over a 4-0 junction box. Input power supply lines should be wired in accordance with all applicable building codes.
- The supply circuit line must be as follows:
100-240VAC, 50/60 Hz, single phase, three wire, capable of supplying 200 Watts.
- The equipment is not deemed compatible with any sort of electrical dimming device. Use line voltage only.
- The power supply circuit line must be routed and wired to the wire harness in compliance with all applicable building codes.



Failure to provide a circuit meeting these minimum standards or complying with local building codes can cause a shock hazard.

Check the length of the Down-Tube to make sure that it is the proper length to install and operate the light without interference or over reach.



Means of Isolation

The Means of Isolation disconnects (Isolates) the light from the source of power. This isolation makes it safe to work on the light. In the case of a ceiling mounted light, the means of isolation is the circuit breaker that supplies the power to the circuit.

Ceiling Structure Construction and Mounting

The Ceiling Mount system will experience various levels of dynamic off center moment during regular use. Therefore, it is crucial that the ceiling structure be strong enough to uphold the weight of the system and support the positioning arms and light head without deflection. The owner and/or owner's contractor has the final responsibility for the strength and rigidity of the ceiling structure. An inadequate ceiling structure may result in serious injury, unintended drift, and/or equipment damage.

Because the ceiling structure is the owner's responsibility, the design and construction recommendation shown below covers only a few of the many possible alternatives that can be used. Medical Illumination highly recommends that the owner consult a structural engineer prior to designing and installing the ceiling structure.

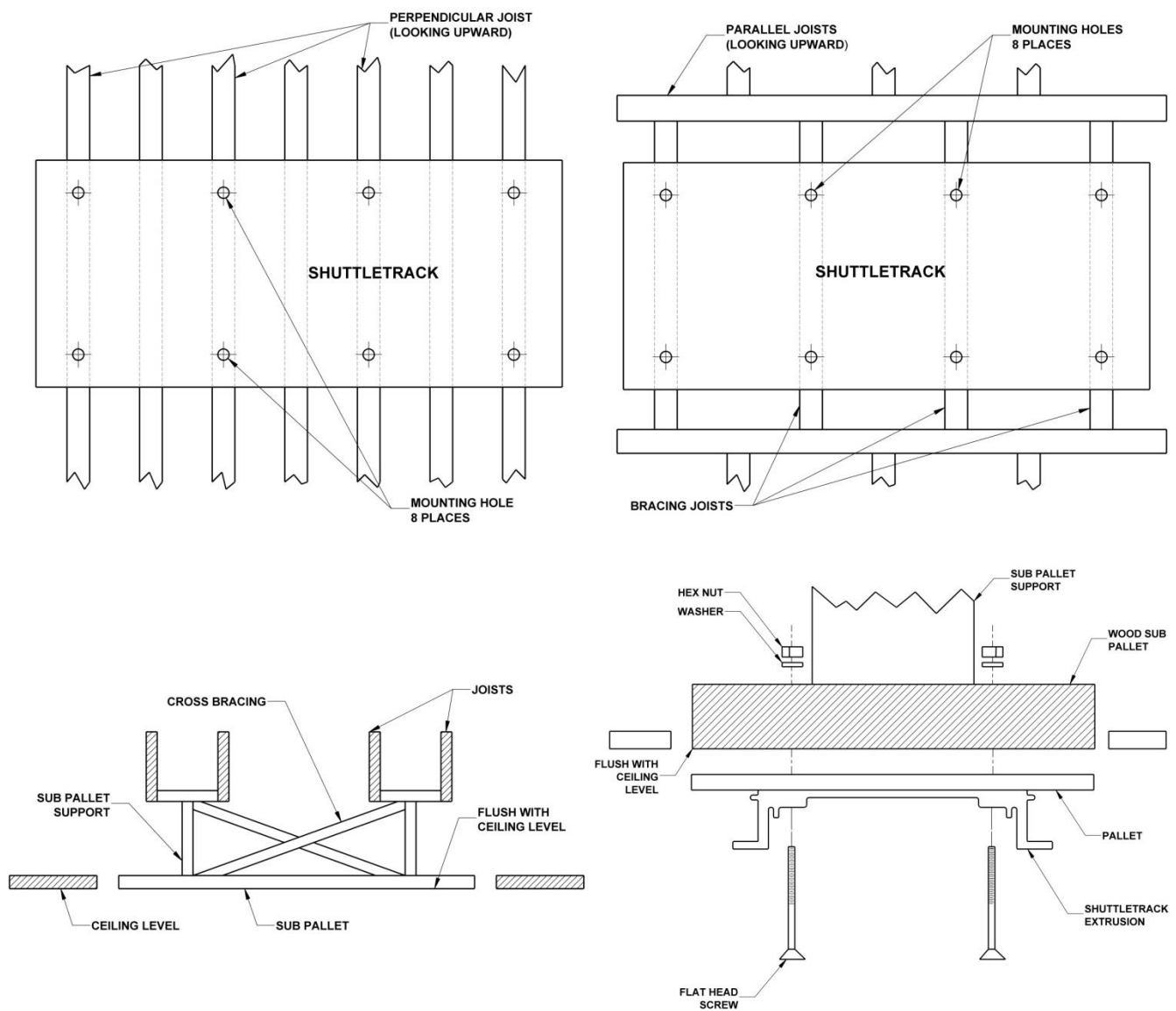
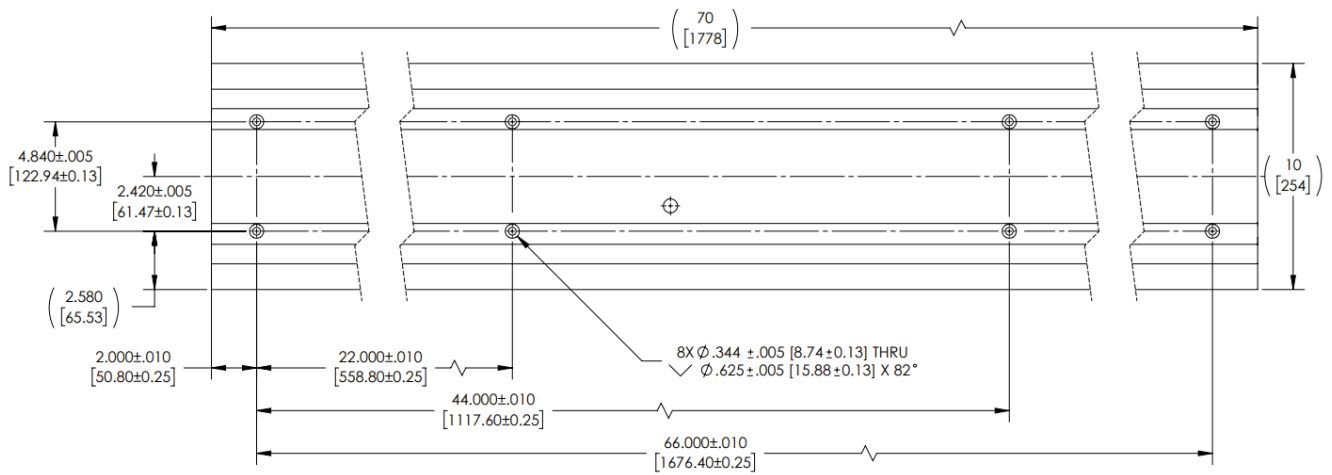

Figure 2: Mounting Methods for the ShuttleTrack



UNLESS OTHERWISE SPECIFIED: DIMENSIONS ARE IN INCHES. DIMENSIONS IN [] ARE IN MILLIMETERS.

Figure 3: Mounting Hole Pattern

Disassembly of the Track Mount Before Installation

⚠ When performing this procedure **DO NOT** disassemble the components of the trolley assembly or remove the track extrusion channel from the plywood pallet.

- Remove the two (2) #6 wood screws from the end plate on the track end with the cable carrier and then remove the end plate.
- For dual Trolley models, remove both end plates.

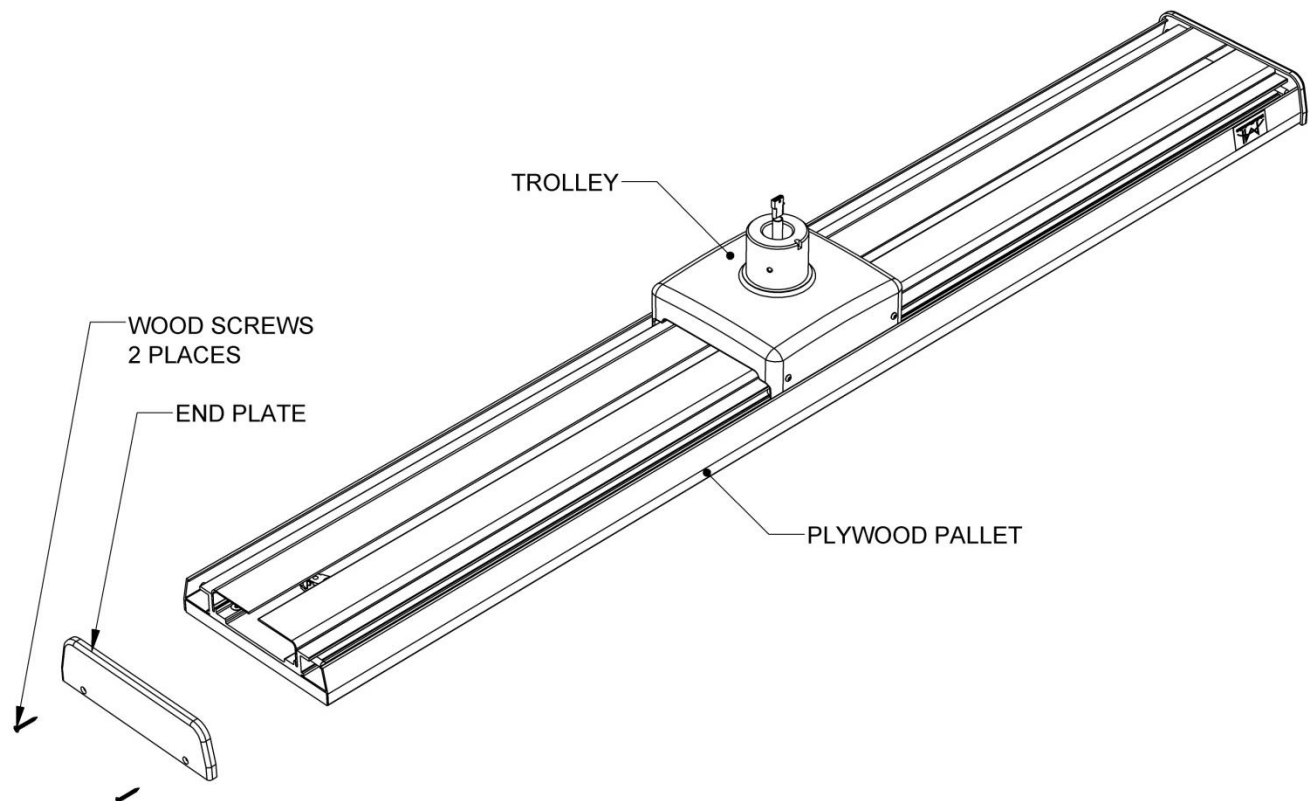

Figure 4: Removing the End Plate

Disassembly of the Track Mount Before Installation - (cont'd)

Take off the two side panels P/N 1001516 by removing the three (3) #10 wood screws on each Side Panel.

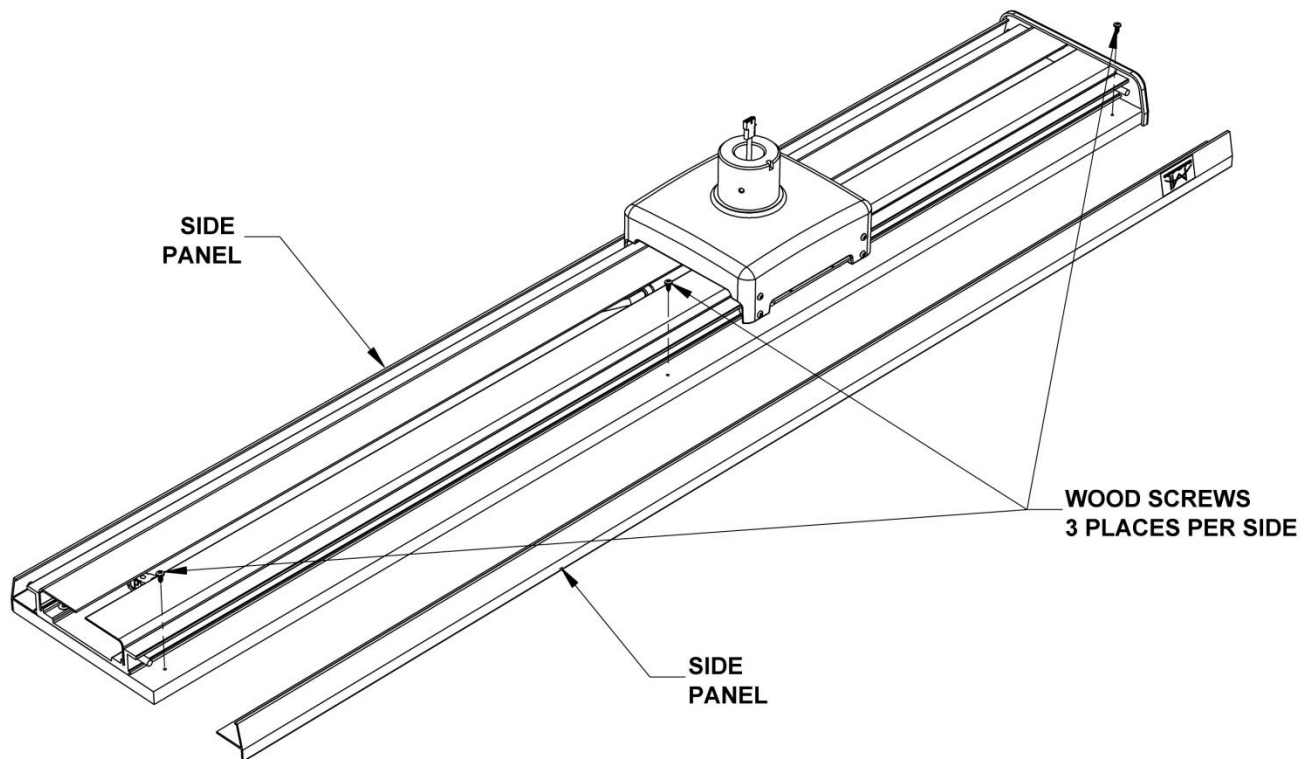

Figure 5: Removing the Side Panels

Disassembly of the Track Mount Before Installation (cont'd)

Loosen the three #8 set screws along each side of the track channel extrusion P/N 1001500 with the provided hex Allen wrench. Remove both dress covers P/N 1001515 by sliding forward. Avoid scratching the covers through the Trolley.

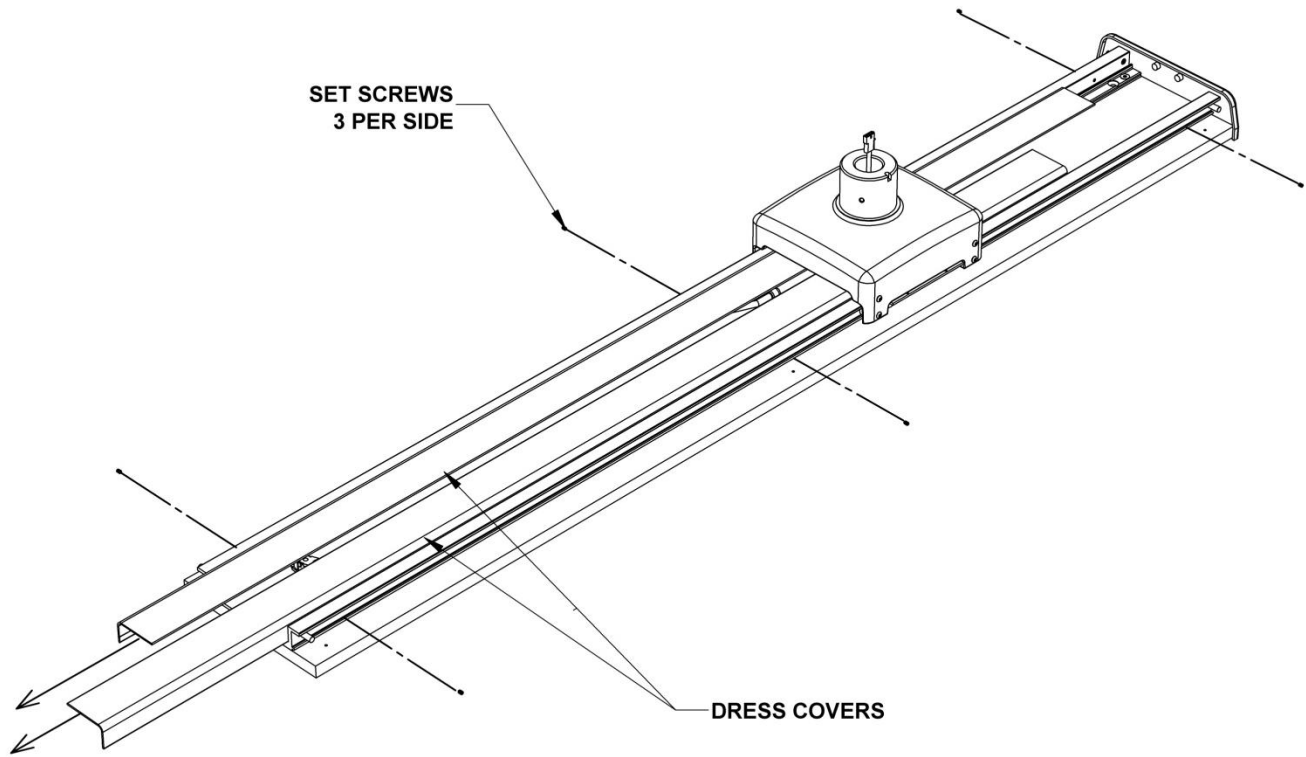

Figure 6: Removing the Dress Covers

Disassembly of the Track Mount Before Installation (cont'd)



Keep the side panels and dress covers in a safe place to prevent damage.

- Remove the two stop pins P/N 1001076 and the #8 flat head screws P/N 0001165 holding the pins in place from the track end with the end plate already removed.
- For dual Trolley models, remove the Stop Pins from both ends of the track.

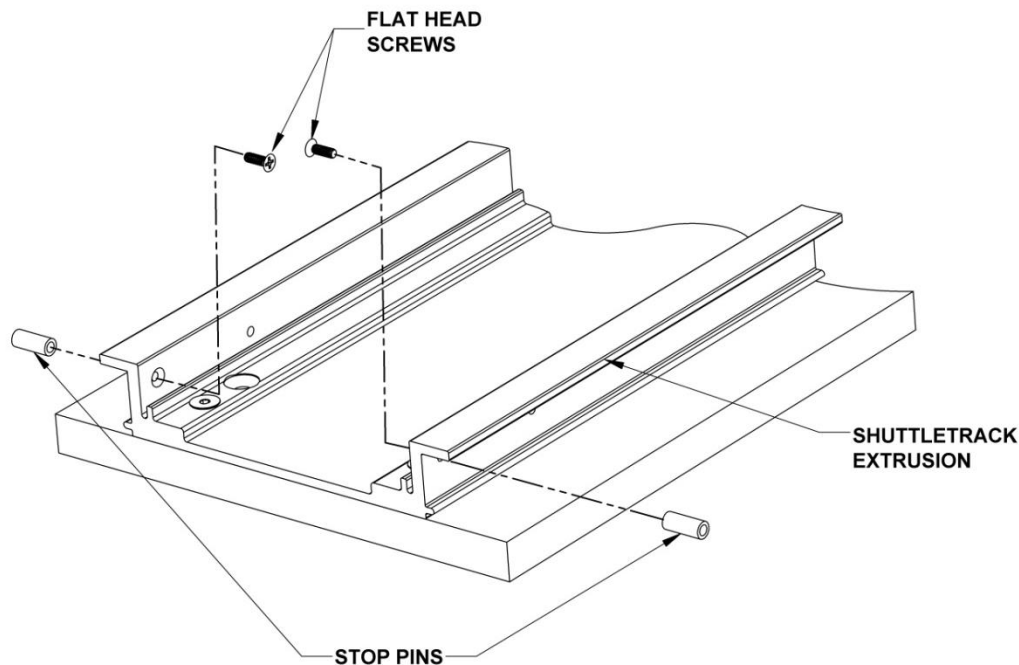

Figure 7: Removing the Stop Pins



Secure all screws and hardware until it is time for reassembly.



Disconnect the Molex connector attached to the Trolley first.

Disassembly of the Track Mount Before Installation (cont'd)

- Slide the Trolley assembly (P/N 1000825) to the edge of the track and then disconnect the cable.
Note: It may be helpful to use tape to temporarily hold the cable carrier in place while mounting the track.
- For dual Trolley models, repeat to remove the second Trolley.

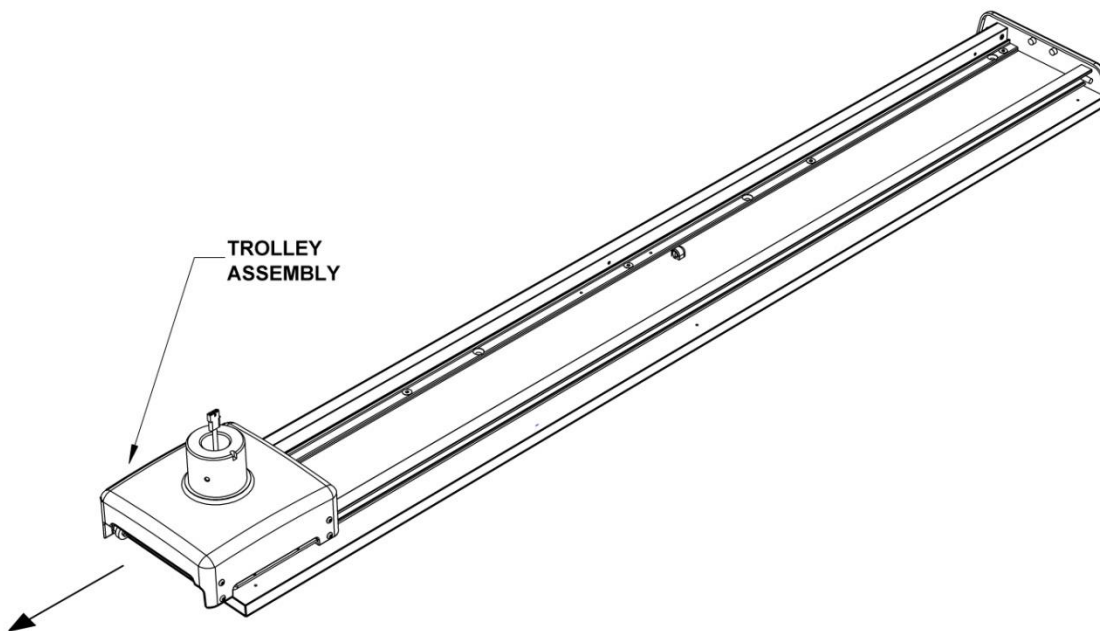



Figure 8: Removing the Trolley

Track Mount Installation Procedure

 **Warning: Improper fastening of the track mount can cause serious injury and/or property damage. Ensure the installation is capable of supporting a weight of at least 231 pounds and an off center load of 626 ft-lbs.**

- Drill the proper sized pilot or clearance holes in the ceiling structure depending on the type of fastener that has been chosen.

 **Note: The next step requires two people to mount the track base. One person is needed to support the ShuttleTrack at the ceiling while the other person fastens the bolts.**

 **Failure to use two people could result in equipment damage and/or personal injury.**

 **Proper movement of the trolley requires the track to be mounted to a level ceiling structure. Check the ceiling with a leveling device in the length and width directions before mounting the base.**

- Install the base to the desired location with eight (8) 5/16" Flat Head Bolt x 4" (minimum length) bolts with flat washers or hex lag screws with washers and nuts. If shimming is required (1/4" or less), flat washers can be placed between the track pallet and the ceiling surface to achieve a level installation.
- An electrical junction box is provided if one is not available in the ceiling. Fasten the box as close as possible to the power cable exiting the back of the track. Route the cable from the track to the junction box then connect the power source to the cable (figure not shown).

 **Note: A ground wire is provided and must be fastened to an earth ground to insure proper grounding reliability for the lighting fixture(s). Wire routing and connections must be done in accordance to local and national electrical codes.**

Track Mount Installation Procedure (cont'd)

- Familiarize yourself with the Trolley and the associated components.

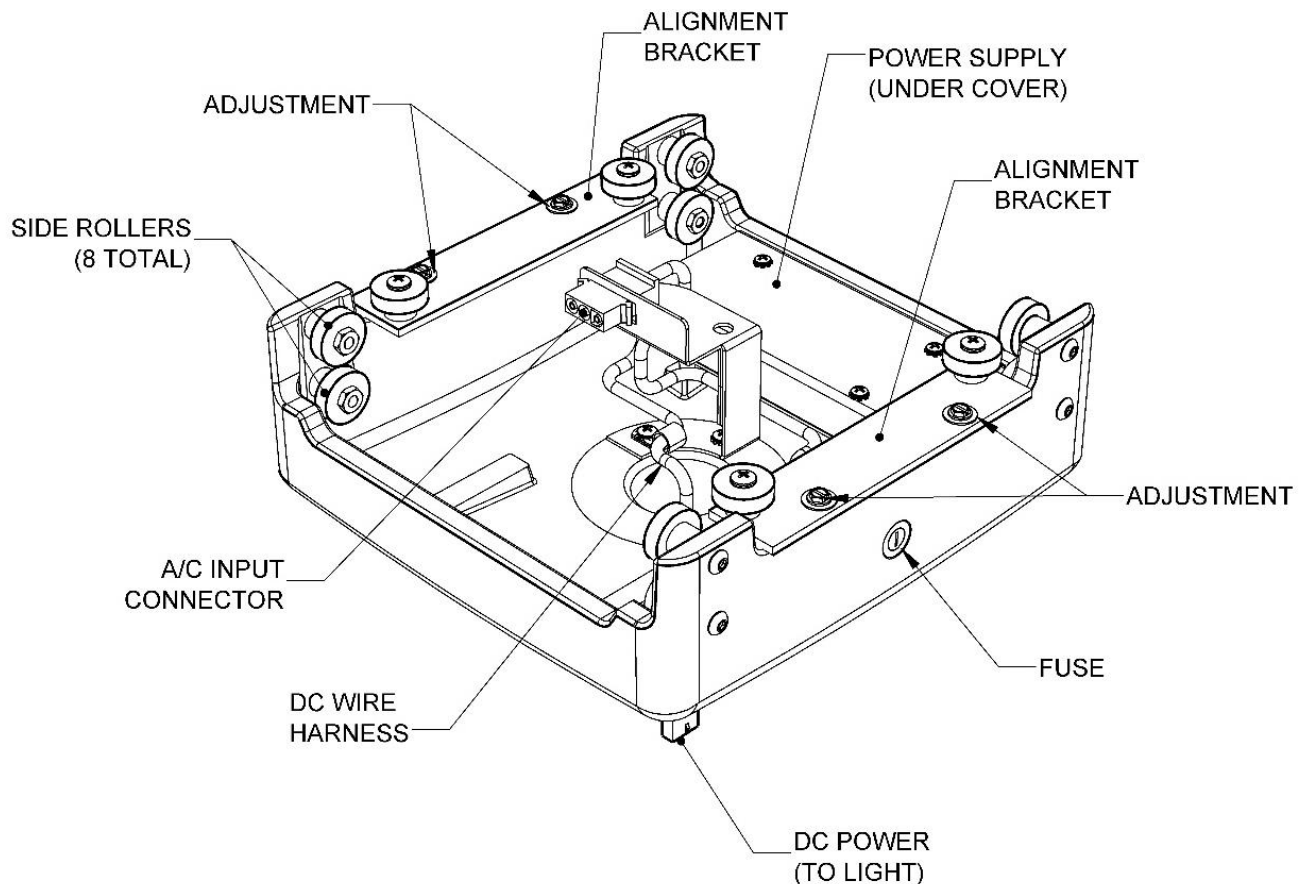

Figure 9: The Trolley Assembly

- Slide the trolley onto the track. The A/C Input Connector in the trolley should be positioned so it is next to the mating Molex connector on the power cord. Ensure that the trolley rolls freely along the track. If adjustment is necessary loosen the adjustment screws and position the side rollers against the base track extrusion.

⚠️ Ensure the power cord does not get twisted when attaching it to the cord bracket on the next step. Do not proceed with the installation before correcting the problem.

Track Mount Installation Procedure (cont'd)

- Ensure the cable carrier chain lays flat within the track. Attach the Molex connector to the mating connector on the trolley assembly.
- For dual Trolley models, slide the second Trolley onto the track and connect the Molex connector.

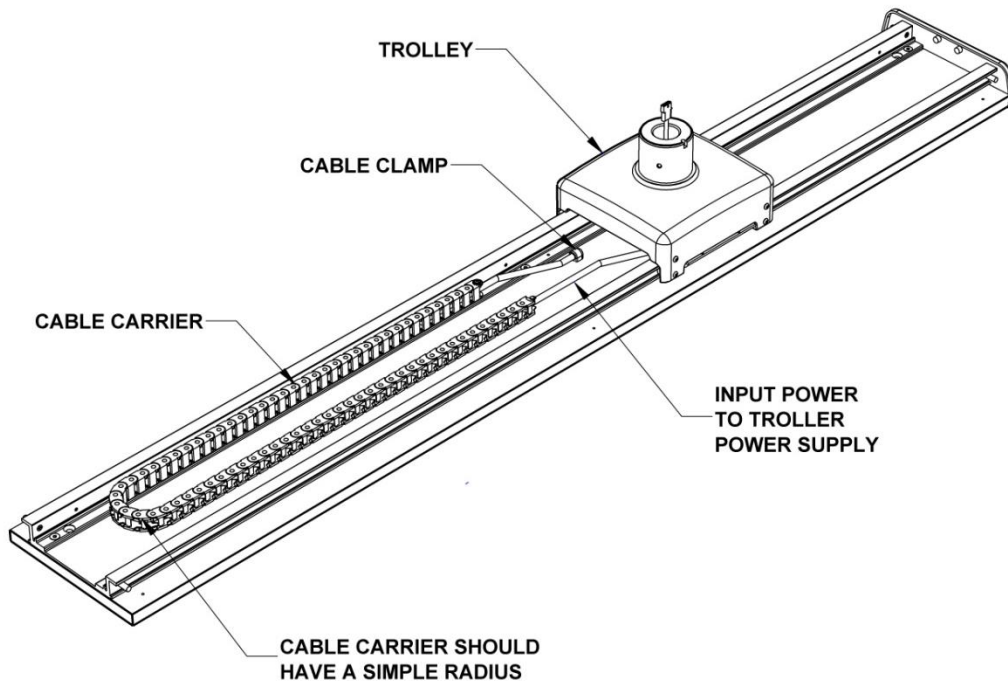

Figure 10: The Carrier Chain

If the cable carrier and trolley move properly along the track, replace the stop pins and screws at the open track end. Carefully slide the center dress covers through the trolley. Be careful not to damage the trolley components, wire connections, or the covers when installing these back. Tighten the three set screws along each side of the track to secure the covers in place.

- Reinstall the side panels and secure in place with the wood screws. Ensure the holes in the pallet are aligned with the holes in the side panel before fastening.
- Reinstall the End Plate(s).
- Install the Down-Tube using the three (3) of the ¼-20 Flat Head Screws provided.
- For the 20" Down-Tube, add the extension cable to the DC Power Cable.

Unpacking the Light System

To begin the installation, remove the Upper Light Head Foam Pads and move the Light Head to a safe place for mounting after the Arm Assembly is securely installed. Use the Light Head Pads to protect the Light Head until it is installed.

With the Arm Assembly still in the Foam Packaging, carefully lift the Foam Packaging and Arm Assembly out of the Carton and place the Foam/Arm Assembly near the light installation. The Carton can also be cut away to access the Foam Packaging from the Carton.

Installing the Arm Assembly

It is recommended that a scissor-lift be used to lift and mount the Arm Assembly. If a scissor-lift is not available the installation can be performed by two people. In either case, carefully lift the Foam Packaging up to the Down Tube. Connect the Light Head Power Connector(s) and then Slide the Arm Shaft up into the Down Tube on the Trolley. Align the holes on the Down Tube to the Arm Shaft and install the six (6) ¼-20 Flat Head Screws

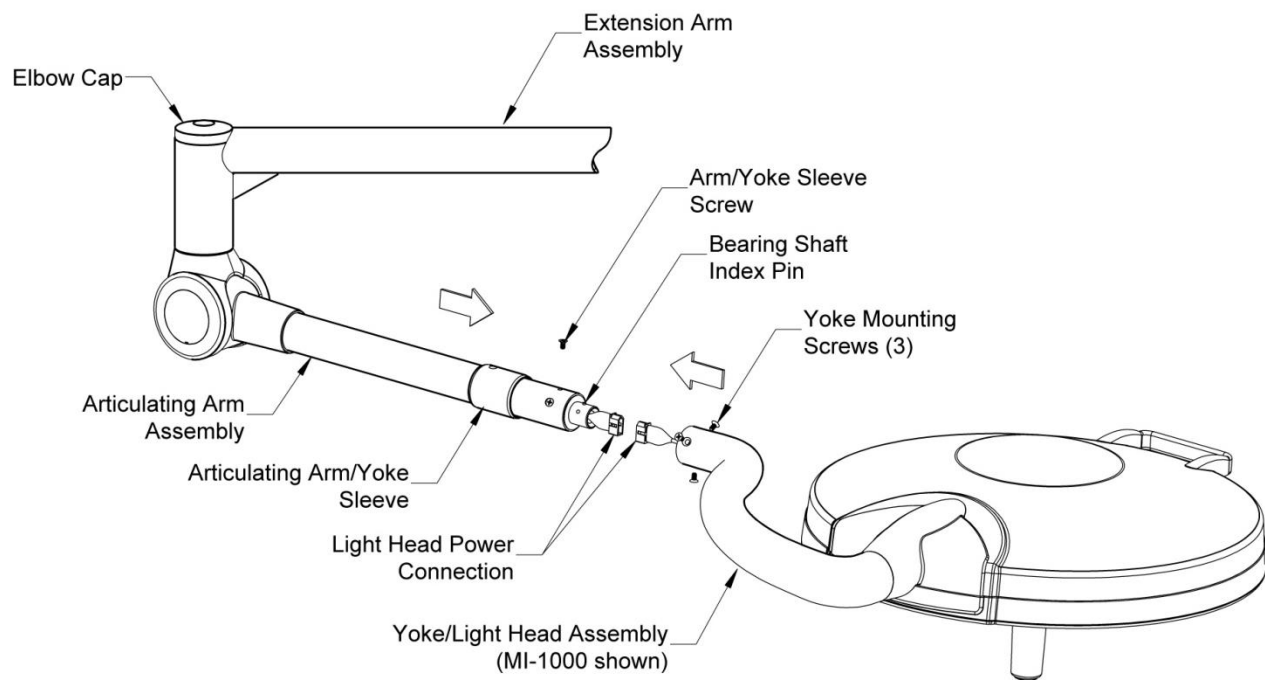

Figure 11: Installing the Light Head

With the Arm Assembly installed and the Extension and Articulating Arms rotate freely without binding, the Light Head is now ready to install. Using two people lower the Articulating Arm to the horizontal position and slide the Articulating Arm/Yoke Sleeve with the screw hole positioned away from the light head onto the arm as shown. Use caution in holding the Articulating Arm in place in that it is spring loaded to accommodate the weight of the Light Head. Next, pre-align the indexing pin on the Bearing Shaft extending out of the Articulating Arm to match the position of the channel located on the inner diameter of the Yoke neck. While supporting the light head, securely connect the Light Head Power Connection. Carefully slide the Yoke onto the Arm Bushing with the indexing pin in the channel on the yoke, ensuring the power-connectors do not bind or disconnect. Attach the three (3) Flat Head Yoke Mounting Screws to secure the Yoke to the Articulating Arm. Slide the Articulating Arm/Yoke Sleeve of the Arm/Yoke Joint and install the Flat Head Screw holding the Sleeve in place.

Section 4: Operating Instructions

 **Ensure that the Light is properly installed before attempting to operate the light and arm mechanism.**

On/Off: To turn the light on or off, depress the on/off intensity button at the end of the sterilizable handle. The light starts at the highest intensity. To dim the light intensity, depress the dimming button on the sterilizable handle. To dim further depress the button again. The intensity levels vary per model. See the Specification Table on page 8 for available dimming levels. The light head will automatically reset to full mode (highest intensity) if the dimming button is depressed with the light on its lowest setting. To turn off the light, depress and hold the button so the light goes into Endo Mode (MI-1000 models only), then depress the button one more time.

Power Failures

If the light experiences a power interruption for any reason, the light is programmed to return to the dimming level that was applied before the power failure. This feature is intended to maintain the same lighting intensity when the power is restored and is applicable to the intensity level, the Endo Mode and the off position.

Positioning the Light Head













 **Ensure that the Light is properly installed before attempting to operate the light and arm mechanism.**

To position the light head and arm over the work area, firmly grasp the Sterilizable Handle and bring the light head or arm to the desired location. Adjust the tilt of the light head by holding the Sterilizable Handle and rotating forward or backward. The light head can revolve around the Yoke/Arm connector by tilting the light head and rotating the head using the sterilizable handle. The arm should move smoothly and remain at the desired position.

Each rotational joint in the arm assemblies allows 540° of rotation before the internal stop mechanism engages. The light head can rotate 300° on the yoke before the internal stop engages.

Section 5: Safety and Maintenance Instructions

Safety Tips

-  Only facility authorized maintenance personnel should troubleshoot the unit. Troubleshooting by unauthorized personnel could result in personal injury and/or property damage.
-  Only facility authorized personnel should repair the unit. Repair by unauthorized personnel could result in personal injury and/or property damage and could void warranty.
-  After completing a repair of the unit, ensure the unit is in proper working order. Failure to do so could result in personal injury and/or property damage
-  Do not touch the LED's or lenses directly. Body oils may significantly lower the optical performance of these parts and may cause equipment damage.
-  Follow the product manufacturer's instructions. Failure to do so could result in personal injury and/or property damage.
-  If the unit fails any part of the preventive maintenance functional checks, repair the unit before use on any patient. Failure to do so could result in personal injury and/or property damage.
-  Do not use harsh cleaners, solvents, or detergents. Failure to do so could result in equipment damage.
-  Do not use silicone-based lubricants. Equipment damage could occur.
-  Turn the power off or unplug the power cord before any repairs are started. Failure to do so could result in personal injury and/or property damage.
-  Do not pinch any wires during installation or during any repair. Pinched wires can cause an electrical shock hazard, resulting in personal injury and/or property damage.
-  Do not expose the unit to excessive moisture. Failure to do so could result in personal injury and/or property damage.
-  Do not rest articles or liquids on top of the Light Head. Spilled liquids will damage the light head and arm assemblies causing an electric shock hazard.

Maintenance

Fuse Replacement

IMPORTANT: Make sure that the power supply disconnected to the light before replacing the fuse(s).

Lights that are connected directly to supply mains require 1 fuse per light head

Lights that are plugged into wall outlets require 2 fuses per light head

Locate the fuse holder locations:



Use only Medical Illumination fuses. See the following table to identify the correct fuse for your model. All fuses must be 250VAC, Slow-Blow. Failure to do so could result in personal injury and/or property damage.

Model	Fuse	MI Part Number
MI-1000	2.5A/250VAC SLO-BLO	0003410
MI-750	1.5A/250VAC SLO-BLO	0001314
MI-550	1.5A/250VAC SLO-BLO	0001314

LED Maintenance



If one or more LED(s) are off and/or generate noticeably dim light output, contact our customer service department at (818) 838-3025. The LED's are not readily replaceable by end users and should only be serviced by Medical Illumination or facility authorized maintenance personnel.

Spring Tension Adjustment Tool

⚠️ ENSURE THAT THE ARM/LIGHT HEAD IS IN ITS HIGHEST VERTICAL POSITION BEFORE ATTEMPTING TO ADJUST THE ARM TENSION. DO NOT OVERTIGHTEN.

The Spring Tension Adjustment Tool (1000736) is required to adjust the spring tension on all MI Spring Arms. This wrench is included in the hardware kit and combines the “Lock” hex drive and the “Adjustment” hex drive into a single wrench. A 5/16” combination wrench (not supplied) is required to Lock and Unlock the Spring Tension Adjustment mechanism.

For safety, it is recommended that the box end of the combination wrench be used when locking the adjustment screw (see illustration).

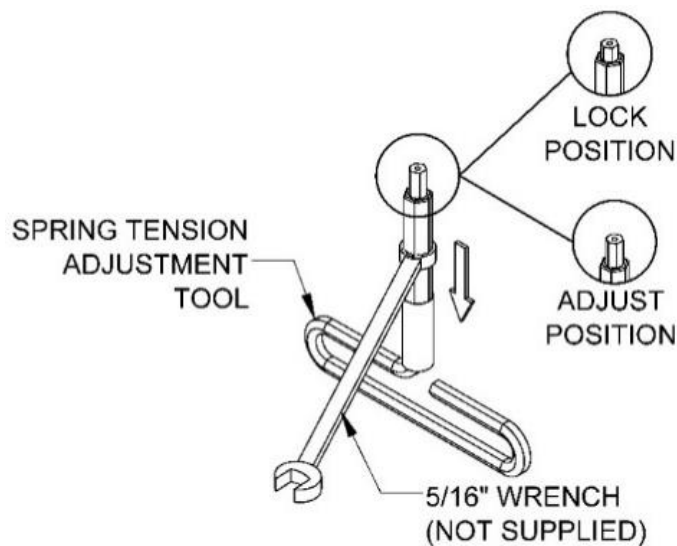

Figure 12: Spring Tension Adjustment Tool

⚠️ DO NOT ATTEMPT SPRING TENSION ADJUSTMENTS WITHOUT THIS WRENCH.

Adjusting the Spring Arm

*****IMPORTANT***** The Spring Arm MUST be rotated up as far as it will go in order to access the spring-tension ADJUSTMENT SCREW and LOCK NUT.

To adjust the spring-tension of the Spring Arm the adjustment screw must first be “unlocked”. To do this, carefully insert the Spring Tension Adjustment Wrench (P/N: 1000736) through the split-rubber receptacle until the smaller hex seats in the ADJUSTMENT SCREW socket and then slide the LOCK (outer) hex upwards until it seats in the LOCK NUT socket. While holding the Wrench stationary, use the 5/16” combination wrench (not supplied) to turn the outer Hex counter-clockwise a quarter of a turn. The ADJUSTMENT SCREW is now unlocked and the spring tension can be adjusted.

To adjust the spring tension, pull the outer hex back so only the ADJUSTMENT SCREW socket is engaged and rotate the wrench handle counter-clockwise to increase tension and clockwise to reduce the tension.

*****IMPORTANT***** The wrench MUST be removed before rotating the Spring Arm vertically to check the adjusted arm tension. Once the spring tension has been set and the Light Head balances, reinsert the Wrench until the small hex seats in the ADJUSTMENT SCREW Socket then slide the outer Hex upwards until it seats in the LOCK NUT socket then while holding the wrench stationary, use the 5/16” combination wrench to lock the LOCK NUT clockwise and the ADJUSTMENT SCREW into place.

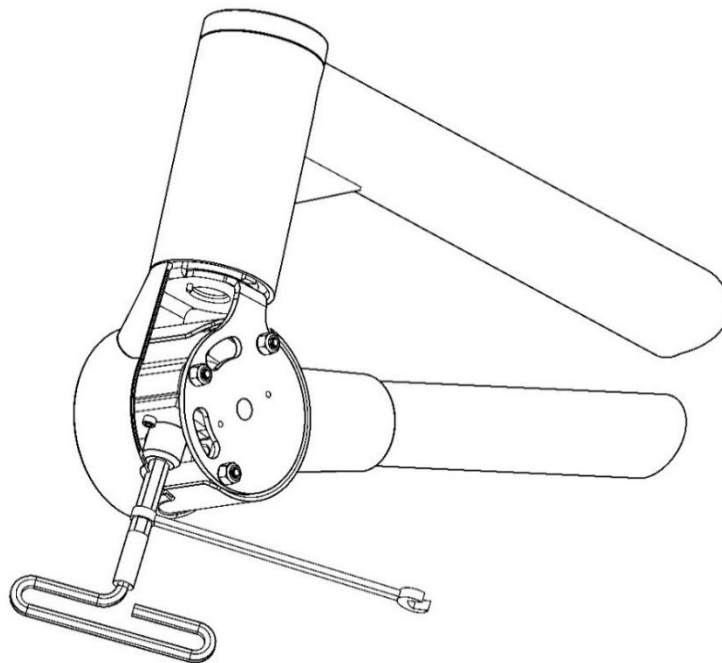



Figure 13: Adjusting Spring Tension

(SHOWN WITH SIDE COVER REMOVED FOR CLARITY)

Cleaning Instructions

- Clean the light housing and arm using mild soap and water mixture. Apply this mixture to a clean cloth and wipe down the light head and arm. Never spray the cleaning fluid directly onto the light head or arm.

 **Do not use harsh cleaners, solvents, or detergents. Failure to do so could result in equipment damage.**

 **The front lens is supplied with a protective hard coat to resist scratching. Never use abrasive cleaners on front lens. Failure to do so could result in equipment damage.**

 **Do not expose the unit to excessive moisture. Failure to do so could result in personal injury and/or property damage.**

Table 1: Preventative Maintenance Schedule

Function	Procedure
Bolts and Nuts	Check to see that all mounting and attachment bolts, set screws, pins, etc. are in place and securely tightened. Replace any missing bolts and re-tighten as required.
Moving Joints & Adjustments	Check to make sure that all moving joints function properly along the mounting system, head and arm assemblies. If the Articulating Arm does not hold position (drifts from original position) refer to arm adjustment section. If the light head drifts, refer to the light head friction adjustment section. If this does not resolve the problem, contact the Customer Service Department in that the unit may require factory repair.
Overall Appearance	Check the general aesthetics of the light system. The unit should be kept clean and dust free. Clean and dust as necessary.

Note: Maintenance schedules vary for each light depending on usage and operating instructions. An annual inspection of the equipment is recommended.

Note: It is highly recommended that the maintenance records for this equipment be kept on file at the health care facility.

Maintenance Schedule

Function	Procedure
Front lens/Optics	Check front lens and optics to assure there are no chips, cracks, or other damage. Do not use equipment if parts are damaged. Replace damaged parts immediately.
Bolts and nuts	Check to see that all mounting and attachment screws, washers, etc. are in place and securely tightened. Replace any missing screws and re-tighten as required.
Moving joints/Adjustments	Check to make sure all moving joints function properly along the mounting system and head and arm system. If the Articulating Arm does not maintain its position properly (drifts from original position) check the mounting plate levelness. If the vertical position fails to maintain its position, use the spring tension adjustment screw. If this does not solve the problem contact customer service as the unit may require factory repair.
Overall appearance	Check the general aesthetics. Units should be kept clean and dust free. Clean and dust as necessary.



Note: Medical Illumination International Inc. recommends that an annual inspection of the equipment and that the maintenance records for this equipment be kept on file at the health care facility.

Component/Assembly Part Numbers

In the event that you require product support, the following part numbers are for reference when calling for support.

Power Supply:0001606-3
 Down Tube:9" - 1001461-9ST
 20" – 1001461-20ST
 Trolley Assembly: 1000825
 Hardware Kit: 1000869

Section 6: Troubleshooting

General Troubleshooting



Warning: Disconnect the light from the power supply before attempting any of the electrical checks mentioned below.

Problem	Possible Cause	Remedy
Light will not turn on or stay on	<ol style="list-style-type: none"> 1. Power to unit is off (not plugged in) 2. Blown (open) fuse 3. Exposed wires are cut or damage 4. Wire not connected correctly during installation. 5. Wire connections made during installation have been disconnected 6. No input power to light unit 7. Disconnected wires at switch or PSU 8. No power output from PSU when input power to PSU is measured 9. Wire connections made during installation have been reversed 10. Sterilizable handle button not engaging power push button switch properly 	<ol style="list-style-type: none"> 1. Turn on power (plug in unit) 2. Replace fuse 3. Replace wire assembly 4. Check all wiring connections 5. Reconnect wires per the instructions. 6. Check power input connections and circuit breakers 7. Reconnect wires 8. Replace PSU 9. Connect proper wires together: black-black and red-red 10. Take off sterilizable handle and inspect handle post assembly with switch. Make sure handle post is tightly assembled. Make sure the button in the sterilizable handle can move freely
Light does not maintain its position vertically	<p>Spring tension is incorrect</p> <p>Additional equipment was added to unit</p>	<p>Adjust spring tension</p> <p>Remove any additional equipment from arm</p>
Light does not maintain its position horizontally	<p>Ceiling Mount Assembly is not level</p> <p>Ceiling Mounting screws are loose</p> <p>Arm/Head needs friction adjustment.</p>	<p>Level Ceiling Mount by shimming</p> <p>Tighten ceiling Mount fasteners.</p> <p>Adjust the friction adjustment</p>

We Want Your Feedback!

Scan the QR code below to tell us about your product experience (est. 5 min).

