



Operating Instructions [EN]

Navigator Lift™ 150 Single, Navigator Lift™ 150 Dual,
Navigator Lift™ 150 Friction Single, Navigator Lift™ 150 Friction Dual,
Navigator Lift™ 250 Friction Single, Navigator Lift™ 150 AirPlus Single,
Navigator Lift™ 150 AirPlus Dual, Navigator Lift™ 250 Single,
Navigator Lift™ 250 AirPlus Single, Navigator Lift™ XL 250 Dual



A member of the
Medical Illumination International Group

Figure 1: Pendant system Navigator Lift™ 150 / 250, Single

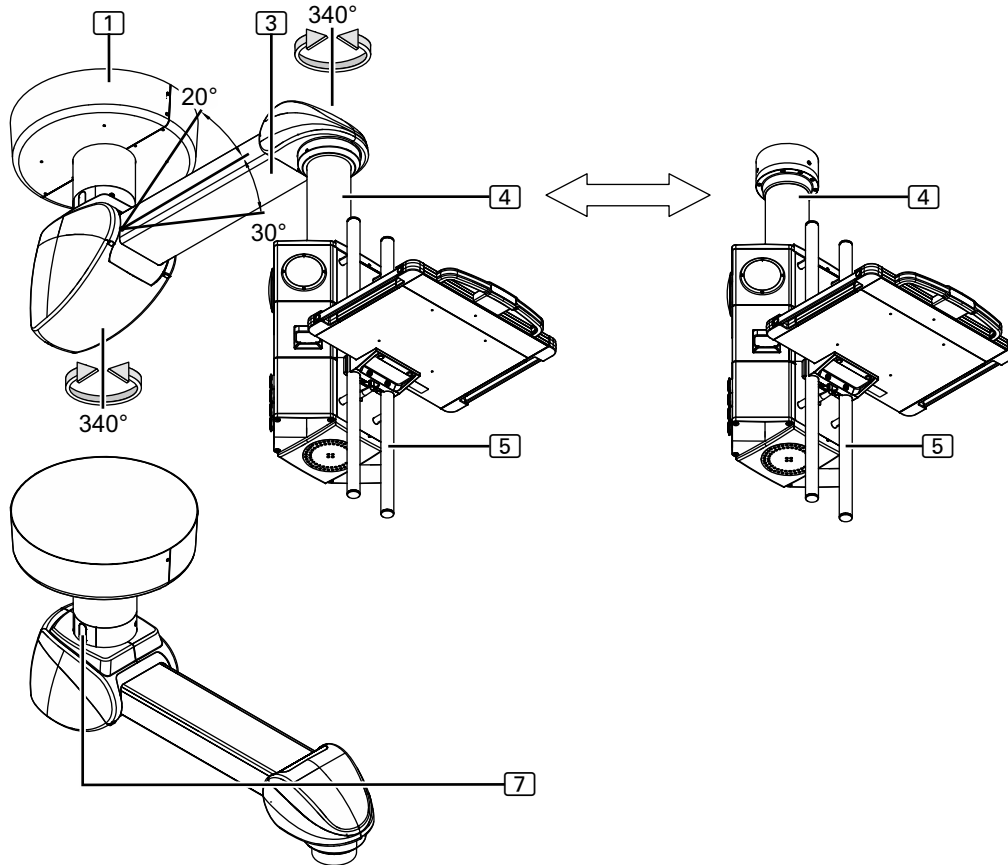
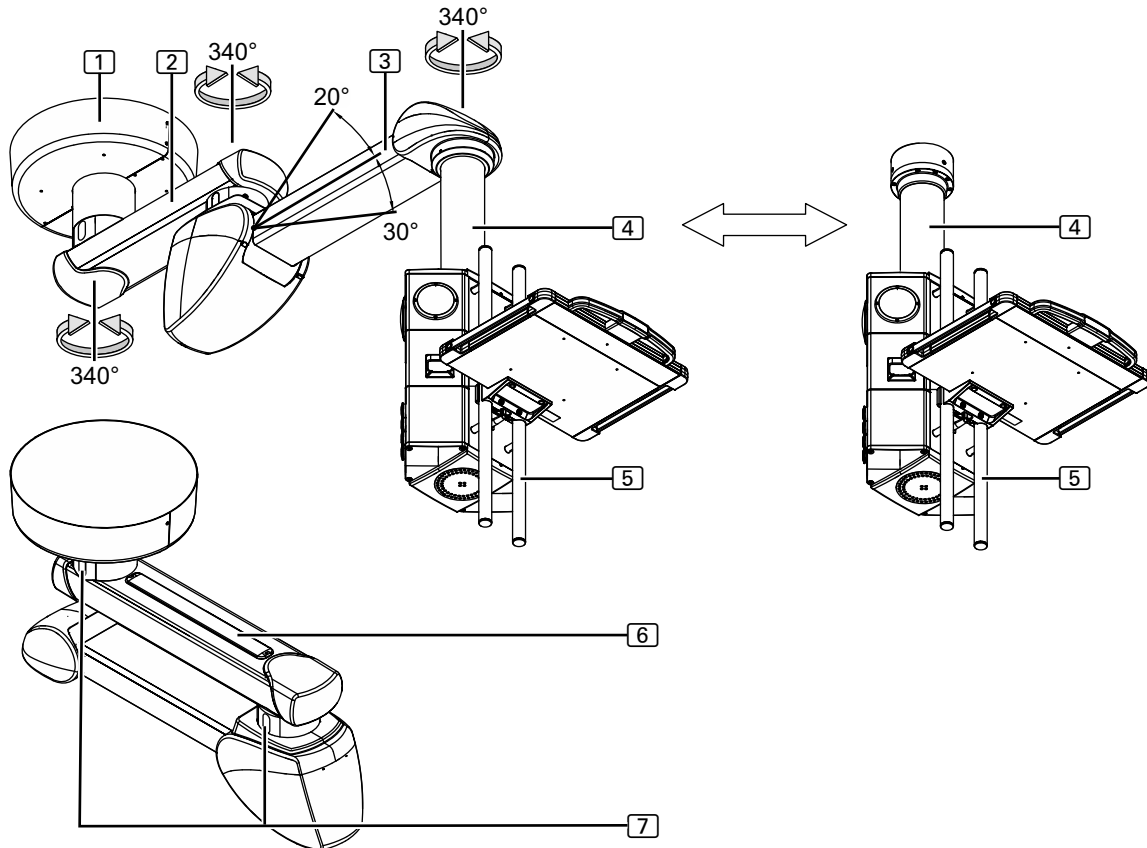
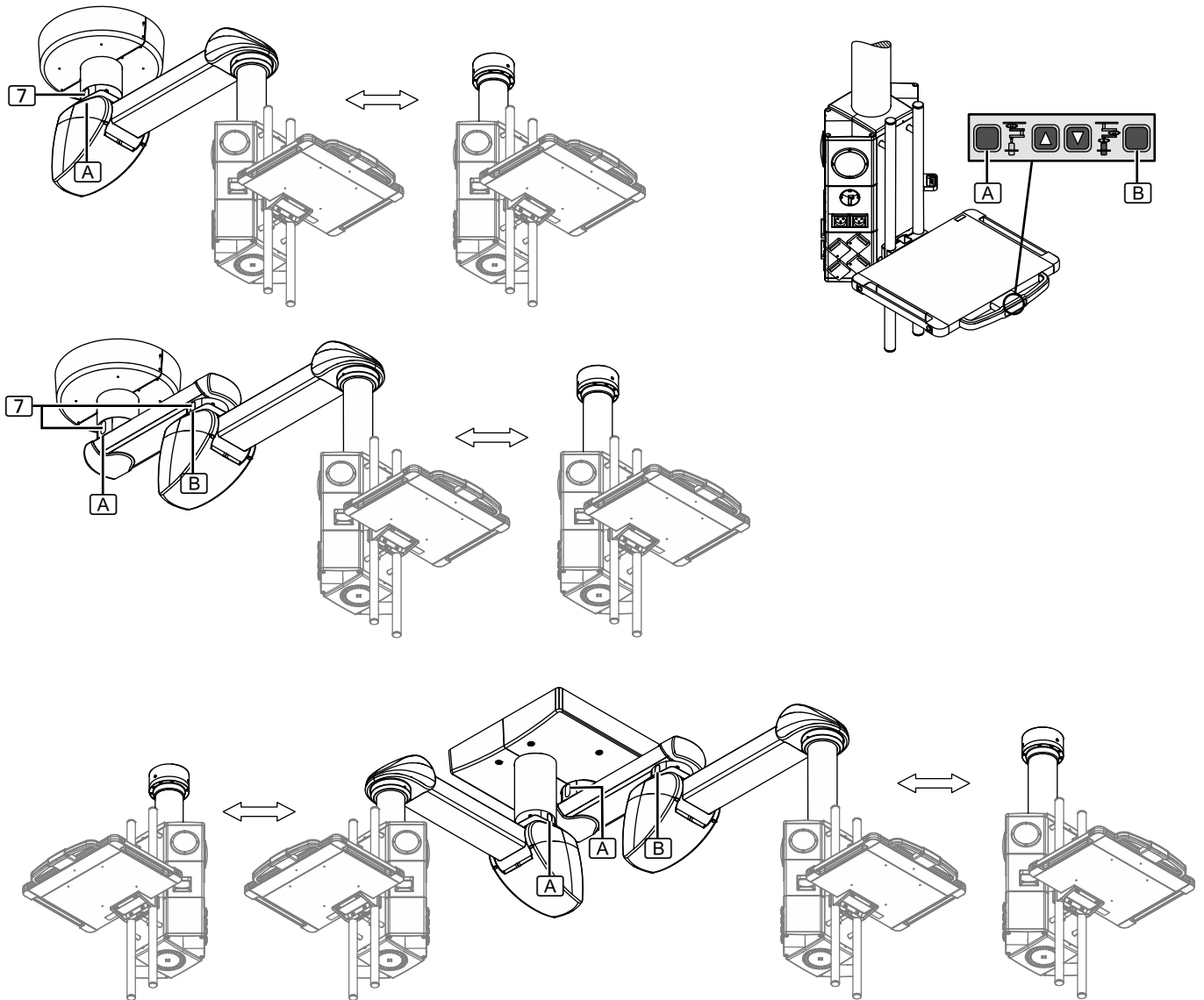

Figure 2: Pendant system Navigator Lift™ 150 / 250, Dual



The two Figures illustrate examples of the pendant systems Navigator Lift™ 150 / 250, Single and Navigator Lift™ 150 / 250, Dual. Please note that your individual pendant system can differ from these illustrations.

Figure 3: Brakes on the pendant system Navigator Lift™ 150 / 250, Single / Dual



For more detailed information on the various brake designs refer to Chapter 2.4.

The example illustrated in the Figure shows the Navigator Lift™ 150 / 250 with extension arm and motor arm.

- ① Canopy
- ② Extension arm or XL extension arm
 - Only for the Dual arm version in different lengths
- ③ Motor arm
 - The motor arm ③ is adjustable in height
- ④ Drop tube
 - The Drop tube ④ has a variable length for compensating different ceiling heights.
- ⑤ Navigator M6
 - For more detailed information on the service head Navigator M6 refer to the Operating Instructions included in the scope of delivery of the Navigator M6.

Optional equipment of the pendant system – Dual arm type

- ⑥ Indirect extension arm lighting (SurroundLED basic C) on the extension arm
 - Auslegerbeleuchtung ⑥ with on/off switch on the Navigator M6 ⑤

Optional equipment of the pendant system – Single and Dual arm type
(only Navigator Lift™ 150 / 250 and Navigator Lift™ XL 250 Dual)

- ⑦ BrakeGuide on the pivot point of the extension arm or XL extension and motor arm
 - When releasing the brake ①, ② via the corresponding brake button ①, ② on the Navigator M6 ⑤, the associated BrakeGuide ⑦ lights up:
 - Pendant system – Dual arm type
 - The upper BrakeGuide ⑦ lights up green
 - The lower BrakeGuide ⑦ lights up blue
 - Pendant system – Single arm type
 - The BrakeGuide ⑦ lights up green

If no BrakeGuide ⑦ is available, plastic parts in different colours are attached to the swivel point on the extension arm or XL extension arm and motor arm in order to be able to locate the brake ①, ② on the corresponding brake button ①, ②:

- Pendant system – Dual arm type
 - The upper plastic part is green
 - The lower plastic part is blue
- Pendant system – Single arm type
 - The plastic part is green

Thank you very much for purchasing this Nuvo product. Please read these Operating Instructions very carefully, abide by the safety notices and observe all operating and cleaning requirements.

For which appliances do these Operating Instructions apply?

- Pendant systems Navigator Lift™ 150 Single, Navigator Lift™ 150 AirPlus Single, Navigator Lift™ 250 Single, Navigator Lift™ 250 AirPlus Single, Navigator Lift™ 150 Dual, Navigator Lift™ 150 AirPlus Dual, Navigator Lift™ XL 250 Dual, Navigator Lift™ 150 Friction Single, Navigator Lift™ 150 Friction Dual, Navigator Lift™ 250 Friction Single
 - Single type – single-arm and dual-arm
 - Duo type and combinations – single-arm and dual-arm

Please do not hesitate to contact our Customer Service team

if you have any questions about the Gerät and its installation, and also in service or warranty cases.

Manufacturer and marketer

Nuvo Surgical • 1565 West 12th Street • Erie, PA 16501 • USA
Phone: +1 (800) 663-1152 (USA and CANADA)
Phone: +1 (814) 899-4220 (INTERNATIONAL)
© Nuvo Surgical, 2019
1568914, Edition 2019-05, Version 0

Visit us on the Internet
E-mail address

www.nuvosurgical.com
sales@nuvosurgical.com

Supplier's address

Space for supplier's stamp or labelNotes on these Operating Instructions

Copyright

- All rights reserved. These Operating Instructions are protected by copyright law.
- Any other use than that regulated by law must be approved in writing by Nuvo Surgical, hereinafter referred to as Nuvo.
- Nuvo does not take any liability for or in relation to the misuse of this information in the prohibited manner by any person or company.

Modifications to the Gerät

Modifications and translations

- Nuvo products are subject to continuous further development. Nuvo reserves the right to modify the form, equipment and technology of the scope of supply without prior notice.

Modifications to the Operating Instructions

- The contents of these Operating Instructions are subject to change without prior notice.

Translations

- In case of translations into foreign languages, the German version of these Operating Instructions shall take precedence.

Trademarks

- All trademarks mentioned in these Operating Instructions are the sole and exclusive property of the corresponding manufacturer.

1	Important Information for Safe Use	10
1.1	Information for identification of the appliance	10
1.2	How to identify the Operating Instructions	10
1.3	Identification of target groups	10
1.3.1	Operator	10
1.3.2	User	10
1.3.3	Qualified personnel	10
1.4	Notes for the operator	11
1.4.1	Initial commissioning	11
1.4.2	Availability of these Operating Instructions	11
1.4.3	Warranty	11
1.5	Notes for the user	12
1.5.1	Instruction on the appliance	12
1.5.2	User's duty to inform and inspect	12
1.5.3	Marking	12
1.5.4	Standards and directives	12
1.6	Intended purpose	13
1.6.1	Incorrect use	13
1.6.2	Contraindications	13
1.7	Ambient conditions	14
1.7.1	Ambient conditions for storage and transport	14
1.7.2	Ambient conditions for operation	14
1.8	Approved Nuvo Products	14
1.9	Combination with products of other manufacturers	14
1.10	Patient environment	15
2	Safety Instructions	16
2.1	Structure of the safety instructions	16
2.1.1	Warnings of risk of injury	16
2.1.2	Warnings of damage to property	16
2.1.3	Indication of additional information	16
2.2	Supplementary symbols used in the safety instructions	16
2.3	Description of graphic symbols possibly used on the appliance and the package	17
2.4	Information on the rating plate	18
2.5	Overview of the most important safety instructions	19
2.5.1	Operation	19
2.5.2	Mounting / dismantling	19
2.5.3	Cleaning and disinfection	20
2.5.4	Maintenance work	20
2.6	Warranty	21
2.7	Proper use of oxygen	21
2.8	Disposal	21
3	Further Applicable Operating Instructions	22
4	Device and Functional Description	23
4.1	Device description	23
4.2	Functional description	23
5	What Are the Max. Load Bearing Capacity and the Max. Loading (Payload)?	25
5.1	What is the maximum load bearing capacity?	25
5.2	What is the maximum loading capacity (payload)?	25
5.3	Structural alterations to the pendant system	25
6	Initial and Repeated Commissioning and Handover	26

7 Adjustments	26
7.1 General safety instructions	26
7.2 Adjusting the mechanical brakes for the extension arm and motor arm	27
7.2.1 Adjusting the brake on the bearing unit (only Navigator Lift™ 150 / 250 AirPlus)	27
7.2.2 Adjusting the brake on the Bearing Unit Friction (only Navigator Lift™ 150 / 250 Friction)	27
7.3 Adjusting the brake on the Drop tube Friction (slide bearing)	28
7.4 Adjusting the brake on the Drop tube Friction (roller bearing)	28
7.5 Adjusting the vertical lift on the motor arm	29
7.5.1 Functioning of the vertical lift	29
7.5.2 Opening the bottom rear cover	29
7.5.3 Adjusting the vertical lift	30
7.5.4 Closing the bottom rear cover	30
7.6 Correcting the vertical alignment of the Navigator M6	31
7.6.1 Opening the bottom rear cover	31
7.6.2 Correcting the vertical alignment	31
7.6.3 Closing the bottom rear cover	31
7.7 Adjusting the swivel stop on the extension arm, motor arm and Drop tube	32
7.7.1 Versions	32
7.7.2 Tool to be used	32
7.7.3 Changing or dismantling the swivel stop	33
7.7.4 Stop recommendation: Dual-arm pendant system with Bearing Unit Friction (roller bearing)	34
7.7.5 Mounting the swivel stop	35
8 Cleaning and Disinfection	36
8.1 General safety instructions	36
8.2 Cleaning	36
8.3 Disinfection	37
9 Maintenance	38
9.1 General safety instructions	38
9.2 Built-in components from third-party manufacturers	38
9.3 Repeated inspection	38
10 Disposal of the Pendant System	38
10.1 Disposal	38
10.2 List of the materials used for the pendant system Technical	38
11 Technical Description	39
12 Technical Data	42
13 Electromagnetic Compatibility (EMC) Information	45
13.1 Guidelines and manufacturer's declarations	45
13.1.1 Electromagnetic emissions	45
13.1.2 Electromagnetic immunity	46
13.1.3 Test specifications	48
14 Approved Nuvo Products	50
15 Optional Accessories	50
16 Possible Combination with Third-Party Products	50
17 Inspection plan	51
Notes	52



Device identification

1.1 Information for identification of the appliance

- These Operating Instructions are intended solely for appliances with the manufacturer's rating plate bearing the following information:
 - Type designation: pendant systems Navigator Lift™ 150 Single, Navigator Lift™ 150 AirPlus Single, Navigator Lift™ 250 Single, Navigator Lift™ 250 AirPlus Single, Navigator Lift™ 150 Dual, Navigator Lift™ 150 AirPlus Dual, Navigator Lift™ XL 250 Dual, Navigator Lift™ 150 Friction Single, Navigator Lift™ 150 Friction Dual, Navigator Lift™ 250 Friction Single



Make sure you are using the latest version

Identification of these Operating Instructions

1.2 How to identify the Operating Instructions

- To ensure that you always have the latest version of these Operating Instructions, every page bears a 7-digit identity number including the date of issue and the version number:
 - Edition:2019-03
- This identification is binding for the validity of the Operating Instructions and must not be removed, regardless of the type of publication (printed form, electronic form or excerpts).



1.3 Identification of target groups

The groups of persons described below are mentioned in these Operating Instructions.

1.3.1 Operator

The following natural persons or legal entities shall be considered as operators:

- all persons who use the appliance in a medical practice, hospital, etc. or hand over the appliance to third parties for use/application, and who have actual physical authority over the appliance during operation.
- The operator shall be liable for handing over a safe appliance and for instructing the user in the proper operation and normal use of the appliance.

1.3.2 User

The following persons shall be considered as users:

- persons who, due to their professional qualification and instruction by the persons designated by the operator, are authorised to operate the appliance and to work with it.
- Users shall be fully responsible for the safe operation of the appliance in accordance with its intended purpose.

1.3.3 Qualified personnel

The following persons shall be considered as qualified personnel:

- persons who underwent special professional training in the field of medicine or medical engineering,
- persons who can assess their work and recognise the potential hazards involved on the basis of their professional experience and instruction in safety-relevant regulations.
- In states where the performance of tasks in the medical or medical engineering sector is subject to certification, qualified personnel must have obtained the corresponding certificate.



1.4 Notes for the operator

- Even though the appliance has been designed according to the state of the art and is safe to operate, it must be considered a potential source of danger, in particular when operated by insufficiently trained personnel or used improperly and not as prescribed.
- The appliance may only be operated, cleaned and disinfected by trained qualified personnel.
- All the mounting, dismantling and adjustment work described in these Operating Instructions may only be carried out by qualified personnel who have been authorised and instructed by the operator.
- For safety reasons, any operator actions or interventions exceeding this scope may only be carried out by Nuvo or companies authorised by Nuvo. As a prerequisite for the authorisation of a company, its service technicians must have successfully participated in technical training organised by Nuvo. This authorisation is granted for a limited period.
- All lengths (mm) and angles (degrees) are approximate values and subject to production-related tolerances.

1.4.1 Initial commissioning

Validity

- These Operating Instructions only apply after initial commissioning has been properly carried out.
- Prior to initial use, the appliance must be thoroughly cleaned and disinfected.
- The instruction for the proper installation of the appliance is included in the Installation Instructions applicable for the appliance.

1.4.2 Availability of these Operating Instructions

Duty to inform

- Since these Operating Instructions are an integral part of the appliance, they must always be kept near the appliance in order to be able to look up safety instructions and important information on use at any time.
- Do not pass on the appliance to any third party without valid Operating Instructions. Based on the ID and version numbers, make sure you hand over an up-to-date and valid version of the Operating Instructions together with the appliance.

1.4.3 Warranty

The warranty of Nuvo for the safety and operational reliability of the appliance is subject to the following conditions:

- The appliance is used exclusively as prescribed and operated as stipulated in these Operating Instructions.
- Only genuine spare parts or accessories and those defined and approved by Nuvo are used. The use of other parts may involve unknown risks and must be avoided in all cases.
- No structural alterations are made to the appliance. Unauthorised modifications or conversions to appliance are not permitted for safety reasons.
- Inspections and maintenance are carried out at the specified time intervals.
- Initial commissioning has been carried out and the appliance has been released for operation by means of a declaration of acceptance.



1.5 Notes for the user

- All the steps described in these Operating Instructions may only be carried out by qualified personnel who have been authorised and instructed by the operator.

1.5.1 Instruction on the appliance

Instruction

- The instruction must be carried out on the appliance immediately by Nuvo, by a company authorised by Nuvo or by a person designated by the operator.
- On completion of the instruction, a certificate must be created and signed in order to document that the user has understood the special operator control actions required for normal use.

1.5.2 User's duty to inform and inspect

Duty to inform and inspect

- Read these Operating Instructions carefully prior to installation of the appliance. This ensures that you benefit from all the advantages of the appliance and prevents any risk of injury or damage.
- Prior to any use or transfer for use, the functional reliability and proper condition of the appliance must be inspected by the user.
- In case of special problems which are not sufficiently described in detail in these Operating Instructions, contact your supplier for your own safety.

Troubleshooting

1.5.3 Marking

CE mark: Nuvo declares that the products comply with the relevant regulations set forth in the applicable European Directives.

CE mark with the ID number of the conformity assessment body indicated: Nuvo declares that the assessment of conformity in accordance with 93/42 EEC (Medical Device Directive) has been performed by the body indicated.

This symbol marks the product as a component approved by a "Nationally Recognized Testing Laboratory" which complies with both Canadian and US deviations from applicable standards.

1.5.4 Standards and directives

The appliance complies with the safety requirements of the following standards, laws and directives:

- Medical Devices Act (MPG)
- 93/42 EEC (Medical Device Directive)
- IEC 60601-1 – Medical Electrical Equipment – Part 1: General Requirements for Basic Safety and Essential Performance

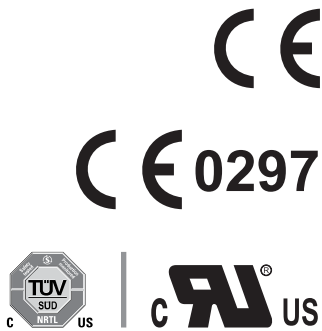



1.6 Intended purpose

- The pendant system is individually equipped; depending on the version and equipment, it serves for:
 - carrying and positioning medical end devices in OR or intensive care rooms and medical environments.
- The conveying and extraction of fluids including:
 - medical gases, vacuum and compressed air (only Navigator M6),
 - electricity and data.
- The pendant system is suitable for continuous operation.

Qualified personnel

- The pendant system may only be operated by instructed, qualified medical personnel.
- The pendant system may only be cleaned and disinfected by instructed hygiene specialists.
- Maintenance work on the pendant system must be carried out by the operator's technical specialist personnel in accordance with the applicable instruction document.

1.6.1 Incorrect use

Duty cycle of the height adjustment mechanism

- The maximum load bearing capacity of the pendant system and its components as specified in Kapitel 12, "Technical Data", Seite 42 must not be exceeded.
- The maximum duty cycle of the height adjustment mechanism on the motor arm must not exceed 3 minutes.
 - If the height adjustment mechanism is actuated over a longer period of time, the electric motor of the motor arm may switch off automatically as a protection measure against overheating.
 - In order to prevent an overload of the electric motor, make sure you wait at least 30 minutes after actuating the height adjustment mechanism before putting the height adjustment mechanism into operation. Afterwards the height adjustment mechanism can be operated once again for 3 minutes.

Duty cycle of the electromagnetic brakes

- The maximum duty cycle of the electromagnetic brakes of the pendant system must not exceed 1 minute.
 - If the electromagnetic brakes are actuated over a longer period of time, the power pack may switch off automatically as a protection measure against overheating.
 - Once the power pack has switched off, it must cool down for 10 minutes and then be disconnected from the mains for 10 seconds before being switched back on again. Normal system operation can only be resumed afterwards. To prevent safety cutoffs, the maximum duty cycle should not be exceeded.

1.6.2 Contraindications

- The pendant system must not be used close to strong magnetic fields.
- No BF or CF application parts in accordance with IEC 60601-1 may be directly connected to the pendant system.



1.7 Ambient conditions

1.7.1 Ambient conditions for storage and transport

The following conditions apply to storage:

- Ambient temperature: -25 °C to 70 °C
- Relative humidity: 10 % to 75 %
- Atmospheric pressure: 500 hPa to 1,060 hPa

1.7.2 Ambient conditions for operation

- Ambient temperature: 10 °C to 40 °C
- Relative humidity: 30 % to 75 %
- Atmospheric pressure: 700 hPa to 1,060 hPa
(This corresponds to a maximum operating altitude of 3,000 m).



1.8 Approved Nuvo Products

The following Nuvo products are approved for use on the pendant system:

- Nuvo products in accordance with Kapitel 14, "Approved Nuvo Products", Seite 50:
 - The components have been adapted to each other and are safe to operate. Any other type of installation, and in particular the use of components from third-party manufacturers, is strictly prohibited because these components can be potential sources of danger.
 - The combination of any other Nuvo product with the pendant system must be approved by Nuvo. If applicable, the conformity assessment must be repeated.



1.9 Combination with products of other manufacturers

Read the Operating Instructions for combined medical products

- The pendant system is combined with the Navigator M6. To prevent dangerous overload, which can lead to a failure or collapse of the pendant system, the maximum load bearing capacity specified in Kapitel 12, "Technical Data", Seite 42 must be adhered to.
 - The party placing the appliance into operation is responsible for the validation of the overall system. A conformity assessment procedure shall be executed if required and a declaration in accordance with Article 12 of 93/42/EEC (Medical Device Directive, MDD) shall be provided.
 - Read the Operating Instructions provided by the third-party manufacturer to obtain the information required for the operation of the end device (e.g. medical device, etc.).
- Power packs intended for the supply of end devices must ensure electrical isolation and provide two protective measures in accordance with IEC 60601-1.



Figure 4: Patient environment, illustration A.9 from IEC 60601

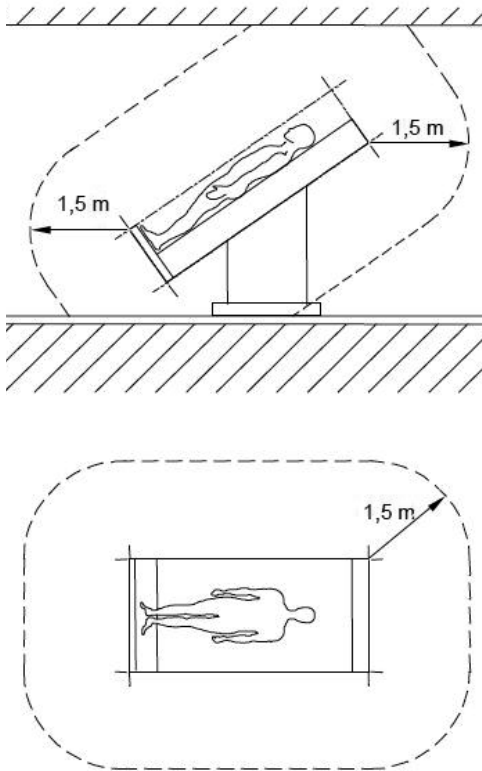

1.10 Patient environment

(See Figure 4)

- If medical electrical appliances with tangible parts are attached to the pendant system and if these are positioned within the patient environment, they must provide two patient protection measures (MOPP) in accordance with IEC 60601-1.
- If tangible parts are positioned outside the patient environment, two Means Of Operator Protection (MOOP) in accordance with IEC 60601-1 must be provided.
- The dimensions in the Figure illustrate the minimum extension of the patient environment in an unrestricted area.

 **DANGER**
 **WARNING**
 **CAUTION**
NOTICE**NOTE**

2.1 Structure of the safety instructions

2.1.1 Warnings of risk of injury

Important notes in this document are marked with graphic symbols and signal words. Signal words such as DANGER, WARNING or CAUTION describe the degree of risk of injury. The triangle symbols visually emphasise the degree of hazard.

DANGER refers to a potential hazard with a high degree of risk which, if not avoided, will lead to death or severe injury.

WARNING refers to a potential hazard with a medium degree of risk which, if not avoided, can lead to death or severe injury.

CAUTION refers to a potential hazard with a low degree of risk which, if not avoided, can lead to minor or moderate injury.

2.1.2 Warnings of damage to property

NOTICE refers to a potential hazard, which, if not avoided, will lead to damage to property.

2.1.3 Indication of additional information

A NOTE provides additional information and useful tips for the safe and efficient use of the appliance.

2.2 Supplementary symbols used in the safety instructions

Explosion hazard: warns of the improper use of oxygen (see Kapitel 2.7, "Proper use of oxygen", Seite 21).

Danger of fire: warns of the improper use of oxygen (see Kapitel 2.7, "Proper use of oxygen", Seite 21).

Electric shock hazard: warns of electric shock which can lead to severe injury or even death.

Risk of parts falling off: warns of parts falling off while carrying out mounting or dismantling work underneath the pendant system.

Tightening torque: warns of the pendant system suddenly dropping because the fixing screws have not been sufficiently tightened or not tightened at all.

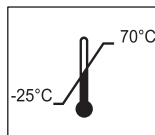
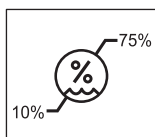
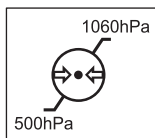

2.3 Description of graphic symbols possibly used on the appliance and the package

Observe the Operating Instructions: Read the Operating Instructions carefully prior to installation of the pendant system. This ensures that you benefit from all the advantages of the pendant system and prevents any risk of injury or damage.

Observe the maximum load bearing capacity or maximum loading capacity (payload): warns of the risk of the appliance suddenly dropping because the maximum load bearing capacity or maximum loading capacity (payload) has been exceeded. The maximum value is indicated in kg or Nm.

General note reminding the user to handle the pendant system with care.

Environmentally friendly disposal: warns of damage to the environment caused by improper disposal of the pendant system (must not be disposed of as normal household waste).

Non-ionising electromagnetic radiation: warns that the high-frequency electromagnetic radiation generated by base transceiver stations and radio transmitters interferes with medical devices and electronic implants.

CE mark: Nuvo declares that the products comply with the relevant regulations set forth in the applicable European Directives.

CE mark with the ID number of the conformity assessment body indicated: Nuvo declares that the assessment of conformity in accordance with 93/42 EEC (Medical Device Directive) has been performed by the body indicated.

This symbol marks the product as a component approved by a "Nationally Recognized Testing Laboratory" which complies with both Canadian and US deviations from applicable standards.

Atmospheric pressure: indicates the permissible atmospheric pressure values in a range from 500hPa to 1060hPa for transport and storage.

Relative humidity: indicates the permissible humidity values in a range from 10% to 75% for transport and storage.

Ambient temperature: indicates the permissible ambient temperature values in a range from -25°C to 70°C for transport and storage.

Figure 5: Information on the rating plate

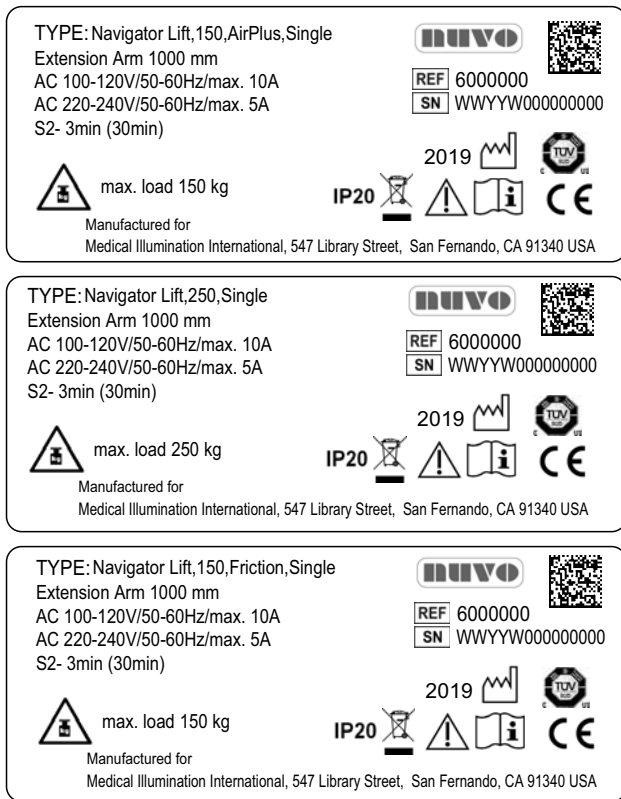

2.4 Information on the rating plate

(See Figure 5)

- The rating plates are attached to the top side of the extension arm or XL extension arm and under the front cover of the motor arm.
- Navigator Lift™ 150 / 250 is the version equipped with electromagnetic brakes.
- Navigator Lift™ 150 / 250 AirPlus is the version equipped with pneumatic (compressed air operated) brakes.
- Navigator Lift™ XL 250 Dual is the version equipped with the XL extension arm.
- Navigator Lift™ 150 Friction is the version equipped with a mechanical brake.

Serial number

- The rating plate indicates the serial number (SN) of the pendant system.

Power supply

- The rating plate provides information on the power supply of the pendant system.

S2-3min (30min) Duty cycle of the height adjustment mechanism

- See Kapitel 12, "Technical Data", Seite 42.

Load bearing capacity

- The value of up to 150kg or 250kg indicates the maximum permissible load bearing capacity of the motor arm.

Date of manufacture

- The digits 1 to 4 of the serial number (SN) indicate the date of manufacture of the pendant system.
- The first two digits indicate the week of manufacture, e.g. 14 = calendar week 14.
- The following two digits indicate the year of manufacture, e.g. 15 = 2015.
- The letter in the 5th position indicates the factory, e.g. H = Hünfeld.
- The digits following the letter indicate the serial number.
- The information and illustrations serve as examples.
- The information and illustrations on the rating plate can vary.

2.5 Overview of the most important safety instructions

The safety instructions in the following chapters must be adhered to.

2.5.1 Operation

WARNING



Risk of the pendant system dropping because the maximum load bearing capacity has been exceeded

If the maximum load bearing capacity has been exceeded, there is a risk that the pendant system or components of the pendant system may disengage from the fastening device and drop:

- The maximum load bearing capacity of the pendant system and components thereof must not be exceeded (see Kapitel 12, "Technical Data", Seite 42)!
- Do not attach or mount additional loads to the pendant system, or the Navigator M6 and end devices.

Collision damage

In case of collision with other devices, walls or ceilings, the pendant system or the Navigator M6 can be damaged and important patient care systems can fail:

- After a collision, the Navigator M6 and the pendant system must be inspected for damage.
- In case of doubt, contact your supplier.

2.5.2 Mounting / dismantling

WARNING



Electric shock hazard

To prevent the risk of electric shock, the pendant system may only be connected to a power supply network equipped with a protective conductor:

- The pendant system must be connected in such a way that it can be disconnected from the mains at all poles and at the same time.

Electric shock hazard

Power supply cables are laid in the pendant system and in the Navigator M6. Contact with energised components presents a danger to life from electric shock. Prior to any installation/dismantling and setting up work, the pendant system must be disconnected from the mains:

- Disconnect all the poles from the mains and prevent the appliance from being switched back on again.
- Make sure that all the appliances connected via the Navigator M6 are de-energised.

WARNING



Risk of parts falling off

During all dismantling and installation work, it must be ensured that no person is in the area underneath the pendant system.

2.5.3 Cleaning and disinfection

Cleaning

WARNING

Risk of contamination and infection of the patient

Parts of the pendant system and the adaptations are made of plastic. Solvents can dissolve plastic materials. Strong acids, bases and agents with an alcoholic strength of more than 60 % can lead to the plastic materials becoming brittle. Detached particles can fall into open wounds. If liquid cleaning agents are allowed to penetrate the pendant system and the adaptations, excess cleaning liquid may drip into open wounds.

Disinfection

CAUTION

Health hazard

Disinfectants can contain substances hazardous to health which, when in contact with the skin and eyes, can cause injuries or affect the respiratory organs when inhaled. Observe the protective measures:

- Observe the hygiene regulations.
- Adhere to the disinfectant manufacturer's instructions.
- Perform surface disinfection every working day and in case of contamination.

2.5.4 Maintenance work

WARNING



Electric shock hazard

Power supply cables are laid in the pendant system and in the Navigator M6. Contact with energised components presents a danger to life from electric shock. Disconnect the pendant system from the mains before any maintenance work:

- Disconnect all the poles from the mains and prevent the appliance from being switched back on again.
- Make sure that all the appliances connected via the Navigator M6 are de-energised.

CAUTION

Maintenance work

- The pendant system must be inspected as specified in Chapter 17, "Inspection plan", on page 89.
- In case of failure or damage, please contact your supplier.

2.6 Warranty

⚠ WARNING



Pendant system dropping

The pendant system and the Navigator M6 are an adapted system with regard to the maximum load bearing capacity. Alterations to the pendant system can result in exceeding the permissible, total or maximum load bearing capacity of the individual components. In this case, there is a risk of the pendant system or components of the pendant system disengaging from the fastening device and dropping.

Nuvo warrants the functional reliability of the pendant system only under the condition that:

- no structural alterations are made to the pendant system. Unauthorised modifications or conversions to the pendant system are not permitted for safety reasons.
- only genuine spare parts or accessories and those defined and approved by Nuvo are used. The use of other parts may involve unknown risks and must be avoided in all cases.
- inspections and maintenance are carried out at the specified time intervals.
- Related documents for dismantling, mounting and adjustment work to be carried out on the adaptations and the motor arms are available from Nuvo on request.
- The party placing the appliance into operation is responsible for the validation of the overall system. A conformity assessment procedure shall be executed if required, and a declaration in accordance with Article 12 of 93/42/EEC (Medical Device Directive, MDD) shall be provided.

2.7 Proper use of oxygen

⚠ DANGER



Oxygen explosion

Oxygen becomes explosive when in contact with oils, greases and lubricants. Compressed oxygen presents an explosion hazard:

- Make sure that the oxygen and gas outlet points are free from oily, greasy and lubricating materials!
- Do not use any cleaning agents containing oil, grease or lubricants.



Danger of fire

Escaping oxygen is combustible:

- Open fire, red hot objects and naked flames not permitted when working with oxygen!
- Do not smoke!

2.8 Disposal

RoHS conformity

- The pendant system complies with the requirements of the 2011/65/EC RoHS Directive (on the restricted use of certain hazardous substances in electrical and electronic equipment).
- To prevent environmental damage and personal injury, we request you to contact us or your authorised service partner if you intend to take the pendant system out of operation for the purpose of disposal.
- The pendant system must be disposed of at a suitable collection point for recyclable waste in accordance with country-specific regulations.

Figure 6: Overview of the structure of the Operating Instructions

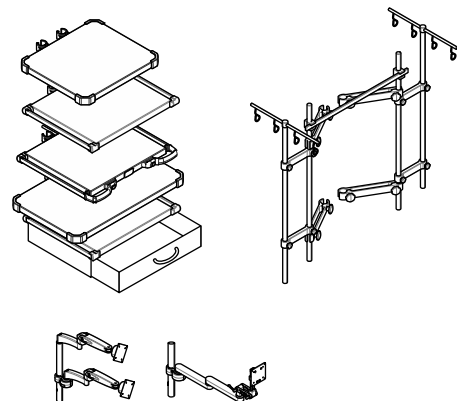
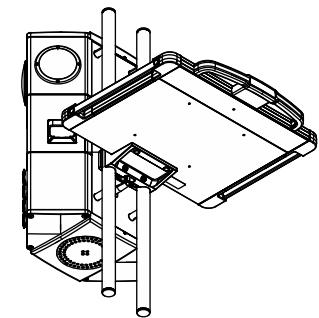
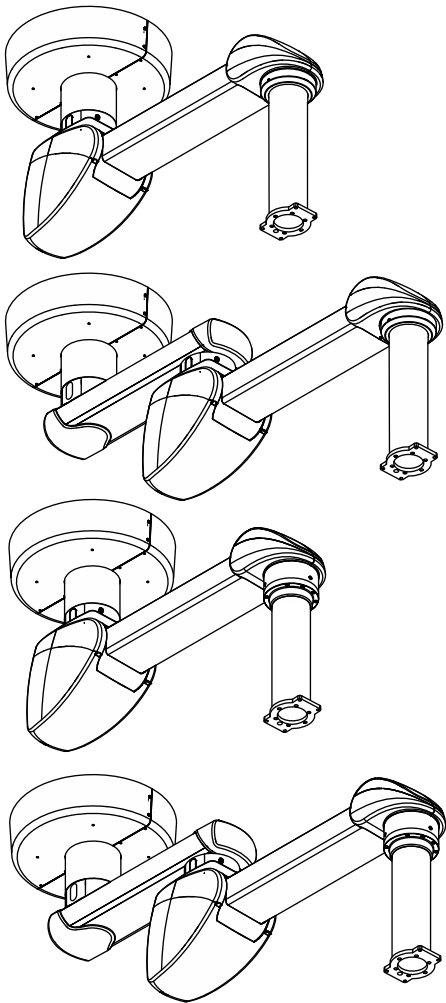

The Operating Instructions of the entire pendant system consist of separate documents. For this reason these Operating Instructions are only valid and complete if all the documents are available at the place of installation.

The following parts must be available:

Part 01: Pendant system

Part 02: Navigator M6

(Observe the Operating Instructions of the gas outlets installed – these Operating Instructions are included in the scope of delivery)

Part 03: Accessories approved for the Navigator M6, see accessories catalogue

4.1 Device description

Canopy	Since the points for connecting the electrical cables of the pendant system are located under the canopy [1], the canopy [1] may only be removed by specialist personnel authorised by the operator.
Extension arm (Dual arm type only)	The extension arm [2] or the XL extension arm [2] can be rotated up to 340 degrees horizontally.
Motor arm (Single and Dual arm type)	The motor arm [3] can be rotated up to 340 degrees horizontally and can be vertically adjusted +20 degrees upwards and -30 degrees downwards.
Drop tube	The length of the Drop tube [4] compensates different ceiling heights in order to ensure that the Navigator M6 [5] is positioned at the working height desired.
Navigator M6	The Navigator M6 [5] can be rotated up to 340 degrees horizontally. For more detailed information on the Navigator M6 [5] refer to the Operating Instructions included in the scope of delivery of the Navigator M6 [5].

4.2 Functional description

Extension arm (Dual arm type only)	The extension arm [2] or XL extension arm [2] serves for the horizontal positioning of the Navigator M6 [5].
Motor arm	The motor arm [3] serves for the horizontal and vertical positioning of the Navigator M6 [5].
End stops on the extension arm, motor arm and Drop tube	In order to prevent collisions with other components or walls, the swivel range of the extension arm [2], extension arm XL [2], motor arm [3] and the Drop tube with roller bearing [4] can be restricted by means of internal end stops. The end stops of the extension arm [2], motor arm [3] and the Drop tube with roller bearing [4] are pre-adjusted at the factory. They can be re-adjusted as described in Kapitel 7.7, Seite 32.
Brake on the extension arm and motor arm	<p>Pendant system Navigator Lift™ 150 / 250: The extension arm [2] and the motor arm [3] are equipped with an electropneumatic brake [A], [B] which keeps the extension arm [2] and the motor arm [3] stable in any adjusted position.</p> <p>Pendant system Navigator Lift™ 150 / 250 Friction: The extension arm [2] and the motor arm [3] are equipped with a mechanical brake which keeps the extension arm [2] and the motor arm [3] stable in any adjusted position. The mechanical brake can be adjusted as described in Kapitel 7.2.2, Seite 27.</p> <p>Pendant system Navigator Lift™ XL 250 Dual: The extension arm XL [2] and the motor arm [3] are equipped with an electropneumatic brake [A], [B] which keeps the extension arm XL [2] and the motor arm [3] stable in any adjusted position.</p> <p>Pendant system MNavigator Lift™ 150 / 250 AirPlus: The extension arm [2] and the motor arm [3] are equipped with a pneumatic (compressed air operated) brake [A], [B] which keeps the extension arm [2] and the motor arm [3] stable in any adjusted position. The additional mechanical brakes (friction brakes) ensure that the extension arm [2] and the motor arm [3] remain stable at the bearing point towards the ceiling tube and also between the extension arm and the motor arm (Dual arm type only) in the case of a failure of the pneumatic (compressed air operated)) brake [A], [B]. The mechanical brake can be adjusted as described in Kapitel 7.2.1, Seite 27.</p>
Brake on the Drop tube	The Drop tube [4] is equipped with a mechanical brake in order to keep the Navigator M6 [5] stable in any adjusted position. The braking force can be adjusted as described in Kapitel 7.2.2, Seite 27 or Kapitel 7.4, Seite 28.

























Releasing the brake	To release the brake  ,  , press the corresponding brake button  ,  on the Navigator M6  . The extension arm  or the XL extension arm  and the motor arm  can be rotated. (For more detailed information on how to correctly operate the brakes refer to the Operating Instructions of the Navigator M6  .
Vertical lift of the motor arm	In order to prevent collisions with other components or the ceiling, the vertical lift of the motor arm  can be restricted. The vertical lift is defined during installation. The vertical lift can be adjusted as described in Kapitel 7.5, Seite 29.
Extension arm lighting (optional)	Only pendant systems Navigator Lift™ 150 Dual arm, Navigator Lift™ 150 Friction Dual Arm, Navigator Lift™ 150 AirPlus Dual Arm, Navigator Lift™ XL 250 Dual Arm: Indirect Extension arm lighting  (SurroundLED basic C) on the extension arm  or XL extension arm  . The Extension arm lighting  is switched on and off via either the on/off switch or a rotary dimmer switch (SurroundLED advanced system) in the light module of the Navigator M6  .
BrakeGuide on the extension arm (optional)	<p>Only Pendant system Navigator Lift™ 150 / 250 and Navigator Lift™ XL 250 Dual – Single and Dual arm type:</p> <p>When releasing the brake ,  via the corresponding brake button ,  on the Navigator M6 , the BrakeGuide  lights up:</p> <p>Pendant system Navigator Lift™ 150 and Navigator Lift™ XL 250 Dual – Dual arm type:</p> <ul style="list-style-type: none"> • The upper BrakeGuide  lights up green • The lower BrakeGuide  lights up blue <p>Pendant system Navigator Lift™ 150 / 250 and Navigator Lift™ XL 250 Dual – Single arm type:</p> <ul style="list-style-type: none"> • The BrakeGuide  lights up green

Figure 7: What is the maximum load bearing capacity?

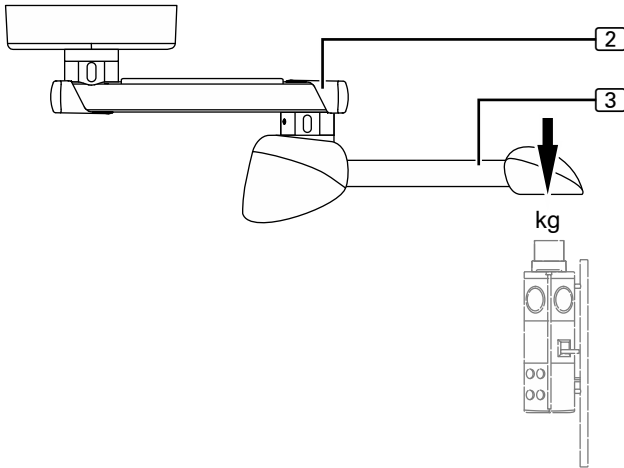
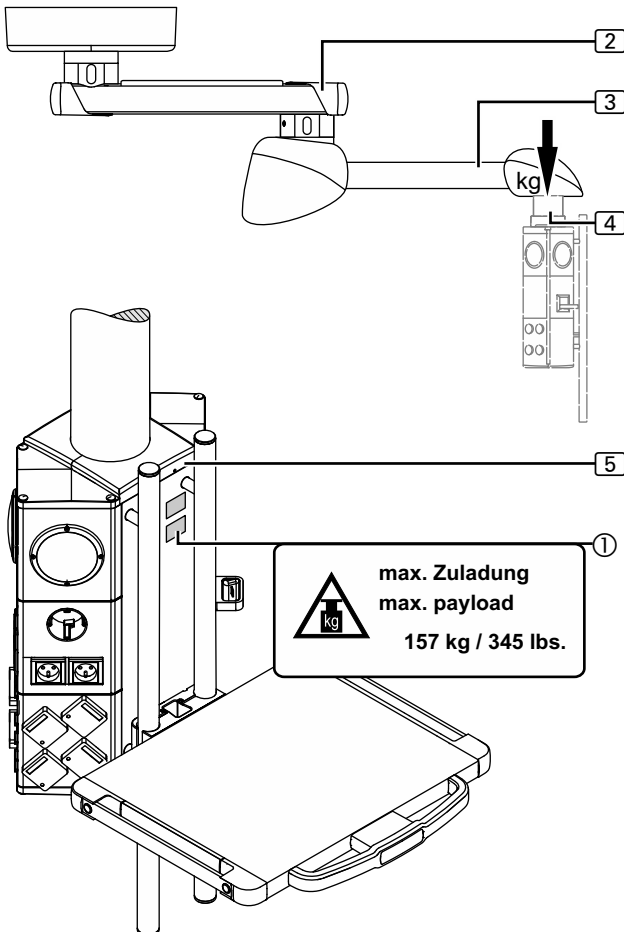

Figure 8: What is the maximum loading capacity (payload)?



5.1 What is the maximum load bearing capacity?

(See Figure 7)

The maximum load bearing capacity is the maximum weight which the extension arm (2) with the motor arm (3) can carry. Table 01 indicates the maximum permissible load bearing capacity of the Single version, Dual arm, on the motor arm (3) using the example of the pendant system Navigator Lift™ 150 – Dual arm. To look up the maximum load bearing capacity of all pendant systems refer to Kapitel 12, “Technical Data”, Seite 42.

Table 01: Maximum load bearing capacity on the pendant system Navigator Lift™ 150 – Dual arm

Dual arm versions	Load bearing capacity [kg]
Extension arm, 600mm, with motor arm	150
Extension arm, 800mm, with motor arm	150
Extension arm, 1,000mm, with motor arm	150
Extension arm, 1,200mm, with motor arm	140

5.2 What is the maximum loading capacity (payload)?

(See Figure 8)

The dead weight of the Drop tube (4) and the Navigator M6 (5) must be subtracted from the maximum load bearing capacity of the pendant system.

This value corresponds to the maximum loading capacity (payload). In the example illustrated in the Figure, the maximum payload is 157 kg / 345 lbs. It is indicated on the adhesive label (1) on the Navigator M6 (5).

If the Drop tube (4) or the Navigator M6 (5) are replaced, the maximum loading capacity (payload) must be recalculated and indicated on the label (1) on the Navigator M6 (5).

For more detailed information on the maximum loading capacity (payload) refer to the Operating Instructions of the Navigator M6 (5).

5.3 Structural alterations to the pendant system

(See Figure 8)

The pendant system is an adapted system with regard to the maximum load bearing capacity and the maximum loading capacity (payload). Alterations to the pendant system can result in exceeding the permissible, total or maximum load bearing capacity of the individual components. In this case, there is a risk of the pendant system or components of the pendant system disengaging from the fastening device and dropping:

- For this reason, structural alterations to the pendant system, including the replacement of the Navigator M6 and the end devices (e.g. HF surgical device, flat screen, etc.), may only be carried out by specialist personnel authorised by the operator whilst taking the maximum load bearing capacity of the extension arm, motor arm and the Navigator M6 into consideration.
- The pendant system may only be dismantled and mounted by the Nuvo technical service team or trained and authorised service personnel.
- Related documents for dismantling, mounting and adjustment work are available from Nuvo on request.

Initial commissioning	<ol style="list-style-type: none"> 1. The pendant system must be properly installed. Instructions for installation are included in the scope of delivery of the product. 2. For commissioning following installation, proper initial commissioning must be carried out for the entire pendant system.
Functional test	<p>Prior to using the pendant system and the Navigator M6 on a patient for the first time, a functional test must take place at the installation site. This functional test must be carried out by the operator or a person authorised by the operator, and the persons authorised by the operator must be duly instructed.</p> <p>This requirement is considered fulfilled if:</p> <ol style="list-style-type: none"> 1. The functional reliability of the pendant system and the Navigator M6 is ensured. 2. The maximum permissible loading capacity (payload) has been safely determined and is indicated on a label attached to the Navigator M6. 3. The proper functioning of the appliance has been approved by the operator during initial commissioning and documented by signing a test report in accordance with Appendix G DIN EN 62353. <p>The following points must be observed during handover to the operator:</p> <ol style="list-style-type: none"> 1. The pendant system and the Navigator M6 must not be handed over to the operator until they have been tested. 2. Handover must be documented in writing including confirmation by the operator. 3. On handover, the operator must be instructed in the functioning and effect of the maximum loading capacity (payload). 4. In addition, the operator must be instructed in the functioning, operation, cleaning and disinfection of the pendant system and the Navigator M6 during the handover procedure. 5. Furthermore, on handover, the operator must be instructed in the adjustments permitted according to the Operating Instructions included in the scope of delivery. 6. On completion of the instruction, an instruction certificate must be created and signed in order to document that the operator/user has understood the special operator control actions required for normal use.

7 Adjustments

7.1 General safety instructions

WARNING



Electric shock hazard

Electrical supply cables are laid in the pendant system. Contact with energised components presents a danger to life from electric shock. **Disconnect the appliance from the mains before any adjustment work:**

- Disconnect all poles of the pendant system from the mains and prevent it from being switched back on again.
- Make sure that all the appliances connected via the Navigator M6 are de-energised.

CAUTION

Performing adjustment work

Adjustment work may only be carried out by qualified personnel who have been authorised and instructed by the operator.

Figure 9: Adjusting the brake on the bearing unit
(only Navigator Lift™ 150 / 250 AirPlus)

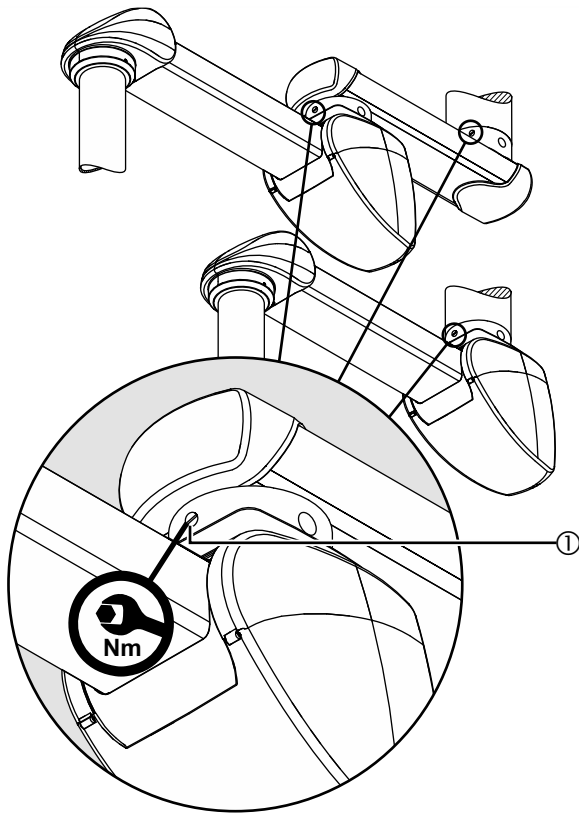
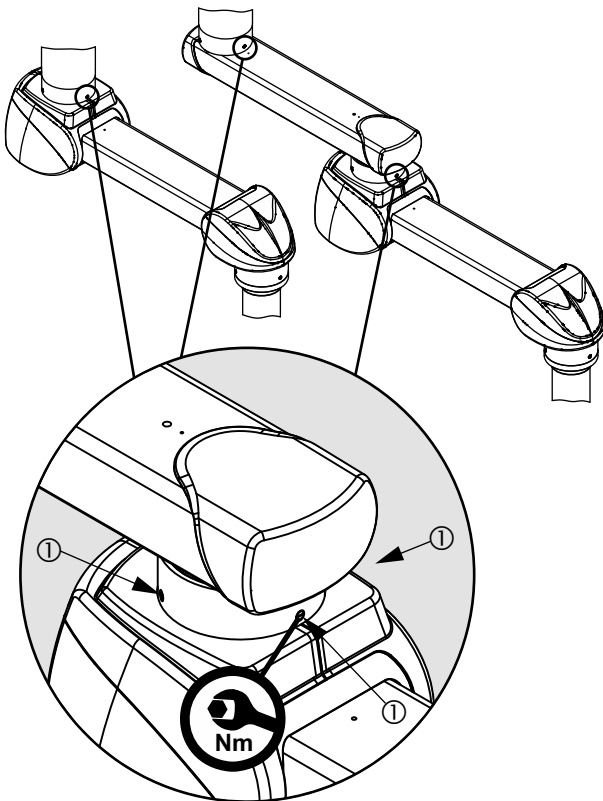

Figure 10: Adjusting the brake on the Bearing Unit Friction
(only Navigator Lift™ 150 / 250 Friction)



7.2 Adjusting the mechanical brakes for the extension arm and motor arm

7.2.1 Adjusting the brake on the bearing unit (only Navigator Lift™ 150 / 250 AirPlus)

(See Figure 9)

In case of a failure of the pneumatic (compressed air operated) brakes, the additional mechanical brakes (friction brakes) of the Navigator Lift™ 150 / 250 AirPlus versions keep the extension arm and motor arm stable in any set position. Adjust the braking force in such a way that the motor arm or extension arm remain stable in any position and can still be conveniently adjusted.

Follow the general safety instructions prescribed in Kapitel 7.1, Seite 26.

- Tool to be used
 - Use a suitable torque spanner.
- To increase the brake force
 - Screw the slotted brake screw ① by uniformly rotating it to the right (clockwise).
 - Tighten the brake screw ① to up to 1.6 Nm.
- To reduce the brake force
 - Unscrew the slotted brake screw ① by uniformly rotating it to the left (anti-clockwise).
- Performing a function test

7.2.2 Adjusting the brake on the Bearing Unit Friction (only Navigator Lift™ 150 / 250 Friction)

(See Figure 10)

For the Navigator Lift™ 150 / 250 Friction version, the mechanical brakes (friction brakes) keep the extension arm or motor arm in any adjusted position. Adjust the braking force in such a way that the motor arm or extension arm remain stable in any position and can still be conveniently adjusted. If the brakes are not adjusted correctly, the extension arm or motor arm can move automatically in an uncontrolled manner.

NOTE: Adjusting the brakes for the Navigator Lift™ 150 Friction Dual
Observe the end stop recommendation in Kapitel 7.7.4, Seite 34 and make sure that you turn the brake screws of the Bearing Unit Friction on the ceiling tube tighter than on the bearing point of the lower extension arm. This facilitates the bending of the motor arm and allows the bearing unit on the motor arm to rotate freely. Follow the general safety instructions prescribed in Kapitel 7.1, Seite 26.

- Tool to be used
 - Use a suitable torque spanner.
- To increase the brake force
 - Screw the slotted brake screws ① by uniformly rotating them to the right (clockwise).
 - All 3 brake screws must be tightened with the same tightening torque which, however, must not exceed 1.6 Nm.
- To reduce the brake force
 - Unscrew the slotted brake screws ① by uniformly rotating them the left (anti-clockwise).
- Performing a function test

Figure 11: Adjusting the brake on the Drop tube Friction (slide bearing)

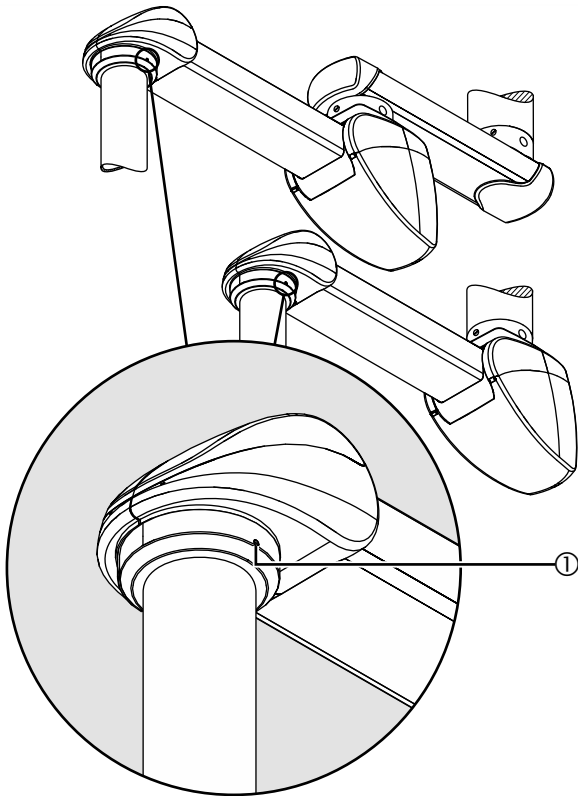
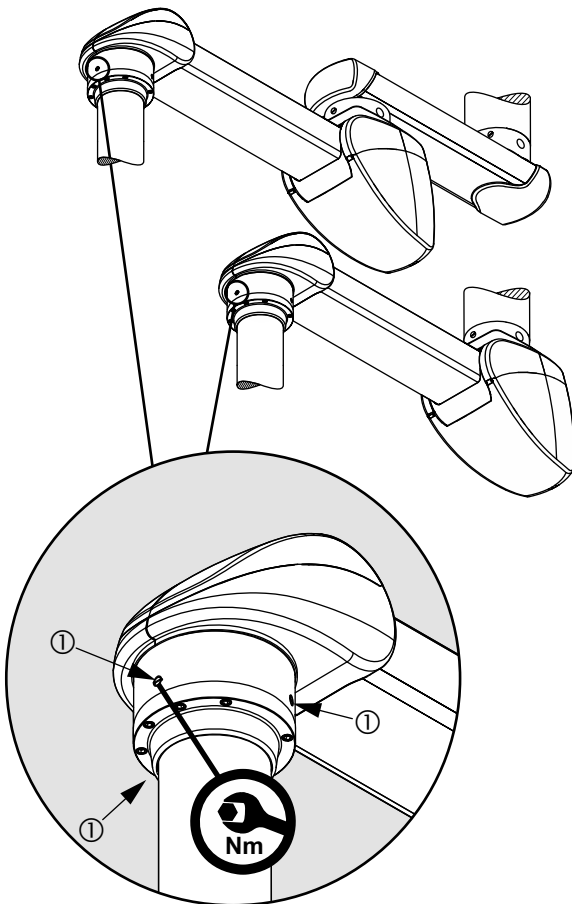

Figure 12: Adjusting the brake on the Drop tube Friction (roller bearing)



7.3 Adjusting the brake on the Drop tube Friction (slide bearing)

(See Figure 11)

For all pendant system versions the mechanical brake (friction brake) on the Drop tube keeps the adaption (e.g. Navigator M6) in the adjusted position.

Adjust the brake force of the corresponding end device (e.g. Navigator M6) such that the end device remains stable in any set position and can still be conveniently adjusted.

Follow the safety instructions

Follow the general safety instructions prescribed in Kapitel 7.1, Seite 26.

Tool to be used

Use a suitable slotted screwdriver.

To increase the brake force

- Insert the slotted screwdriver into the brake screw ① and turn in the clockwise direction.

To reduce the brake force

- Insert the slotted screwdriver into the brake screw ① and turn in the anti-clockwise direction.

- Perform a function test.

7.4 Adjusting the brake on the Drop tube Friction (roller bearing)

(See Figure 12)

The brake screws (friction brakes) are adjusted in the same way for all the different pendant system versions.

In the case of the Drop tube with friction bearing unit, the mechanical brakes ① (3 friction brakes) maintain the end device (e.g. Navigator M6) in the adjusted position.

Adjust the braking force in such a way that the corresponding end device (e.g. Navigator M6) remains stable in any set position and can still be conveniently adjusted.

Follow the safety instructions

Follow the general safety instructions prescribed in Kapitel 7.1, Seite 26.

- Tool to be used

- Use a suitable torque spanner.

- To increase the brake force

- Screw the slotted brake screws ① by uniformly rotating them to the right (clockwise).
- All 3 brake screws must be tightened with the same tightening torque which, however, must not exceed 1.6 Nm.

- To reduce the brake force

- Unscrew the slotted brake screws ① by uniformly rotating them to the left (anti-clockwise).

- Performing a function test

Figure 13: Opening the bottom rear cover

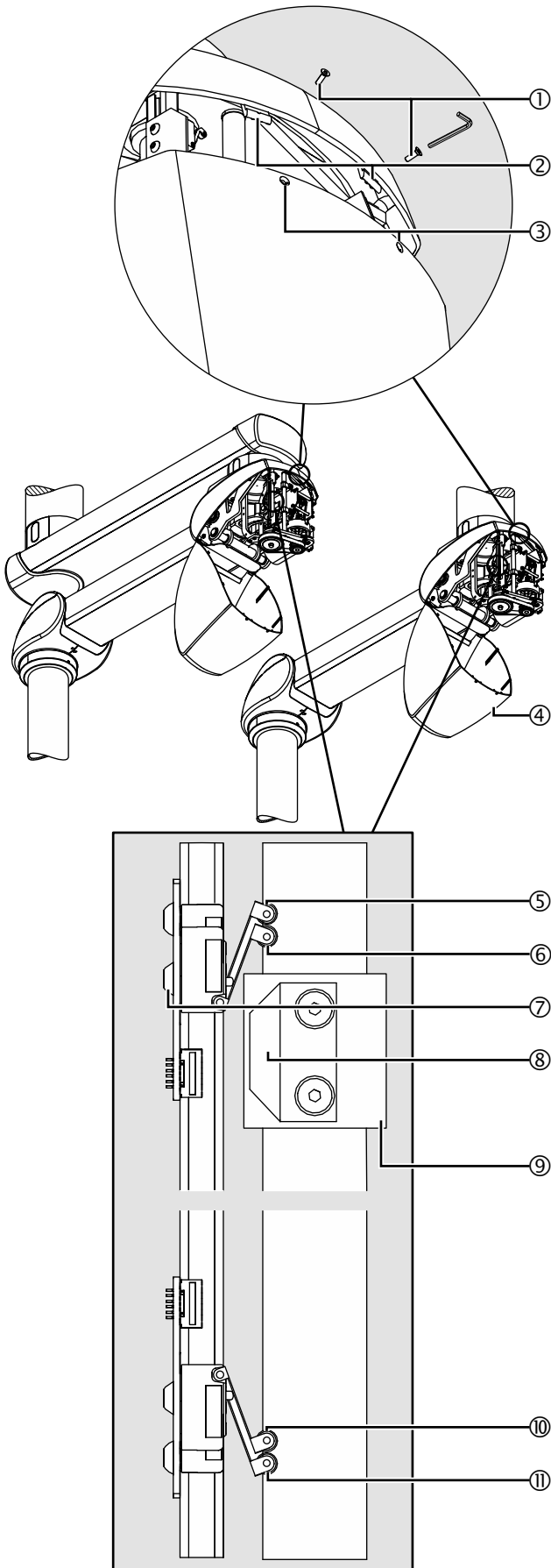

7.5 Adjusting the vertical lift on the motor arm

(See Figure 13)

The simplified representation illustrates the extension arm and motor arm without the cables mounted.

The adjustment is identical for all versions.

The motor arm has a vertical lift of + 20 degrees in the upwards direction and – 30 degrees in the downwards direction. The vertical lift can be restricted in both the upwards and the downwards direction.

7.5.1 Functioning of the vertical lift

(See Figure 13)

1. To adjust the height of the motor arm, the end stop ⑧ on the ball screw nut ⑨ is routed towards 2 upper end switches ⑤/⑥ and 2 lower end switches ⑩/⑪ which switch off the motor.
2. The end switch ⑥ or ⑩ actuated first by the end stop ⑧ ensures a decelerated starting or braking (SoftStart / SoftStop) of the motor. The second end switch ⑤ or ⑪ switches off the motor.
3. The upper and lower vertical lifts are adjusted separately from each other and one after the other. To adjust the vertical lift, move the motor arm to the desired upper or lower height position.
4. Disconnect all poles of the pendant system from the mains and prevent it from being switched back on again.

7.5.2 Opening the bottom rear cover

(See Figure 13)

Tool to be used

Use an Allen key (size 2).

5. Follow the general safety instructions prescribed in Kapitel 7.1, Seite 26.
6. Unscrew the 2 Allen countersunk screws M3 x 10mm ① from the 2 openings ③ .
7. Disengage the 2 latches ② .
8. Manually route the bottom rear cover ④ completely downwards until it points downwards in a fully vertical position.
 - To remove the cover ④ , swivel it approx. 45 degrees downwards. Make sure that this position is passed before releasing the cover ④ .

Figure 14: Adjusting the vertical lift and closing the bottom rear cover

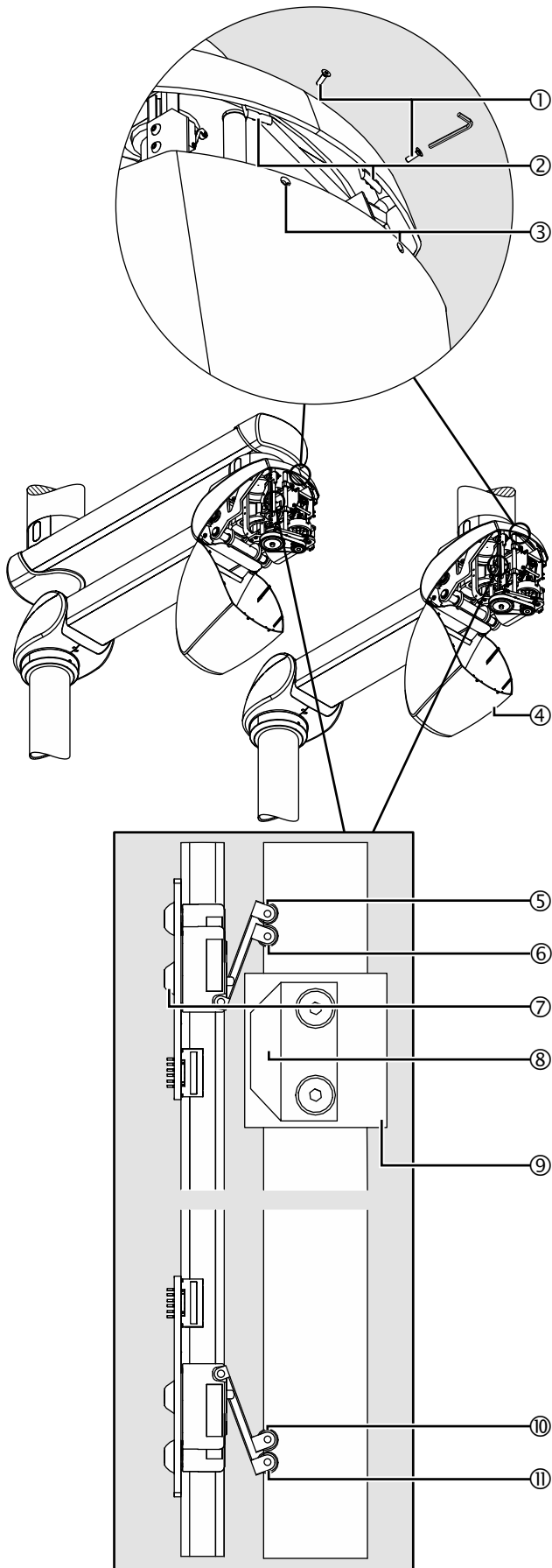

7.5.3 Adjusting the vertical lift

(See Figure 14)

Tool to be used

Use an Allen key (size 2.5).

9. Unscrew 2 Allen countersunk screws M4 x 6mm ⑦ – ISO 7380 – 10.9.
10. Push the circuit board with the end switches ⑤/⑥ towards the end stop ⑧ until the end switch ⑤ or ⑩ audibly clicks into place and then tighten the 2 Allen countersunk screws M4 x 6mm ⑦ – ISO 7380 – 10.9.

NOTICE

Risk of damaging the motor arm

If the motor arm is moved without a correctly installed end switch, the motor arm can be damaged and must be replaced:

- Never move the motor arm without a correctly installed end switch.



The vertical lift adjustment can change gradually during operation if the Allen countersunk screws M4 x 6mm ⑦ – ISO 7380 – 10.9 have not been properly tightened:

In this case there is a risk of the motor arm hitting the ceiling or another pendant system:

- Tighten the Allen countersunk screws M4 x 6mm ⑥ to 3Nm.

11. Close the bottom rear cover ④ as described in Kapitel 7.5.4, Seite 30 and perform a function test.
12. Repeat these steps for the end switches ⑩/⑪ if required.

7.5.4 Closing the bottom rear cover

(See Figure 14)

13. Fold up the bottom rear cover ④ until the 2 latches ② snap into place.
14. Check that the cover ④ is securely in place:
 - The guides (not illustrated in the Figure) of the cover ④ must sit in the side cover panels.
 - The cover ④ must sit on the side panels without gaps.
15. Insert 2 Allen countersunk screws M3 x 10mm ① into the openings ③ in the cover ④ and tighten them.

Figure 15: Correcting the vertical alignment of the Navigator M6

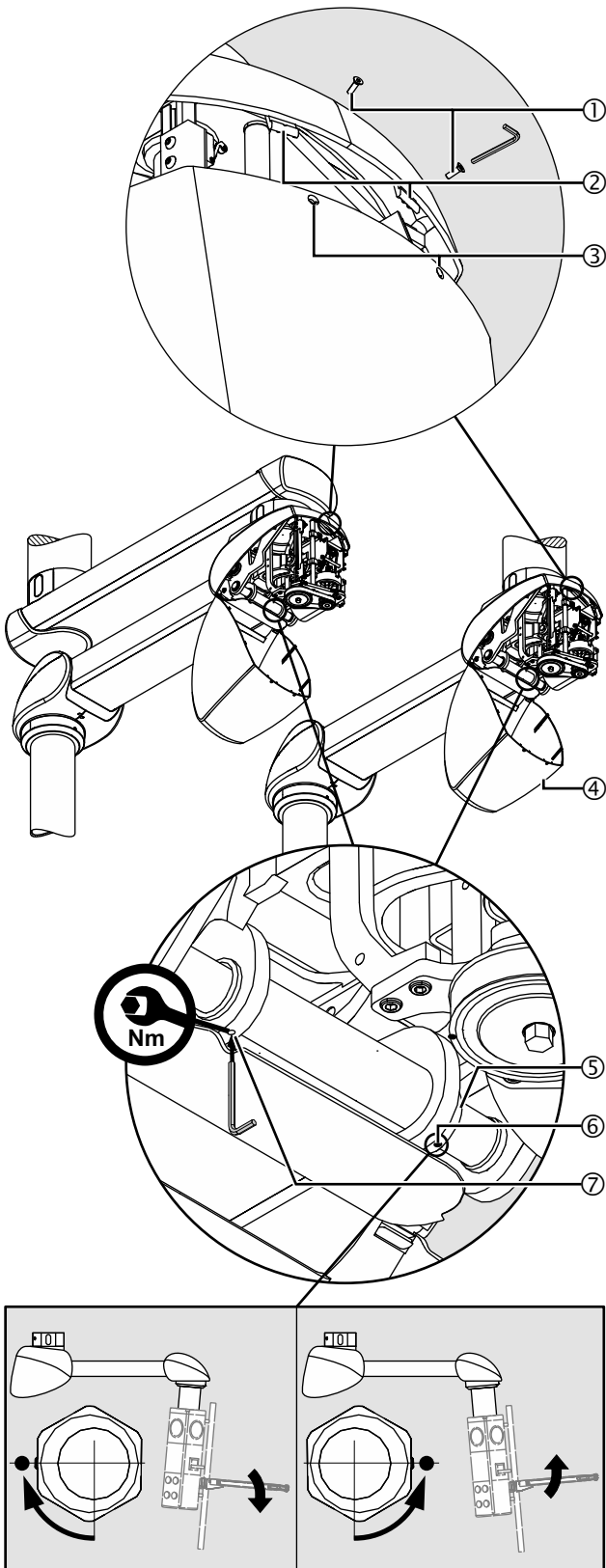

7.6 Correcting the vertical alignment of the Navigator M6

(See Figure 15)

After mounting an end device (e.g. medical device, etc.), it may be necessary to vertically align this end device.

7.6.1 Opening the bottom rear cover

(See Figure 15)

Tool to be used

Use an Allen key (size 2).

1. Follow the general safety instructions prescribed in Kapitel 7.1, Seite 26.
2. Unscrew the 2 Allen countersunk screws M3 x 10mm ① from the 2 openings ③.
3. Disengage the 2 latches ②.
4. Route the bottom rear cover ④ completely downwards until it points downwards in a fully vertical position.
 - To remove the cover ④, swivel it approx. 45 degrees downwards. Make sure that this position is passed before releasing the cover ④.

7.6.2 Correcting the vertical alignment

(See Figure 15)

Tool to be used

Use an Allen key (size 4) and a spanner wrench (size 36).

5. Loosen the setscrew M4 ⑦ – DIN 914.
6. Place the spanner wrench onto the hexagonal bolt ⑤.
 - The indicator screw ⑥ points downwards (do not loosen this screw).

To lower e.g. the shelf:

- Rotate the hexagonal bolt ⑤ such that the indicator screw ⑥ points forwards (towards you). See "Figure 15:" Detail view, bottom.

To lift e.g. the shelf:

- Turn the hexagonal bolt ⑤ such that the indicator screw ⑥ points backwards (away from you). See "Figure 15:" Detail view, bottom.

7. Perform a function test.
8. Tighten the setscrew M4 ⑦ – DIN 914.

NOTE – Vertical alignment changing



The vertical alignment can change progressively during use if the setscrew M4 ⑦ – DIN 914 has not been properly tightened:

The Navigator M6 no longer remains stable in its adjusted position:

- Tighten the setscrew M4 ⑦ – DIN 914 with a tightening torque of 2Nm.

7.6.3 Closing the bottom rear cover

(See Figure 15)

9. Close the bottom rear cover ④ as described in Kapitel 7.5.4, Seite 30.

Figure 16: Adjusting the swivel stop on the extension arm, motor arm and Drop tube

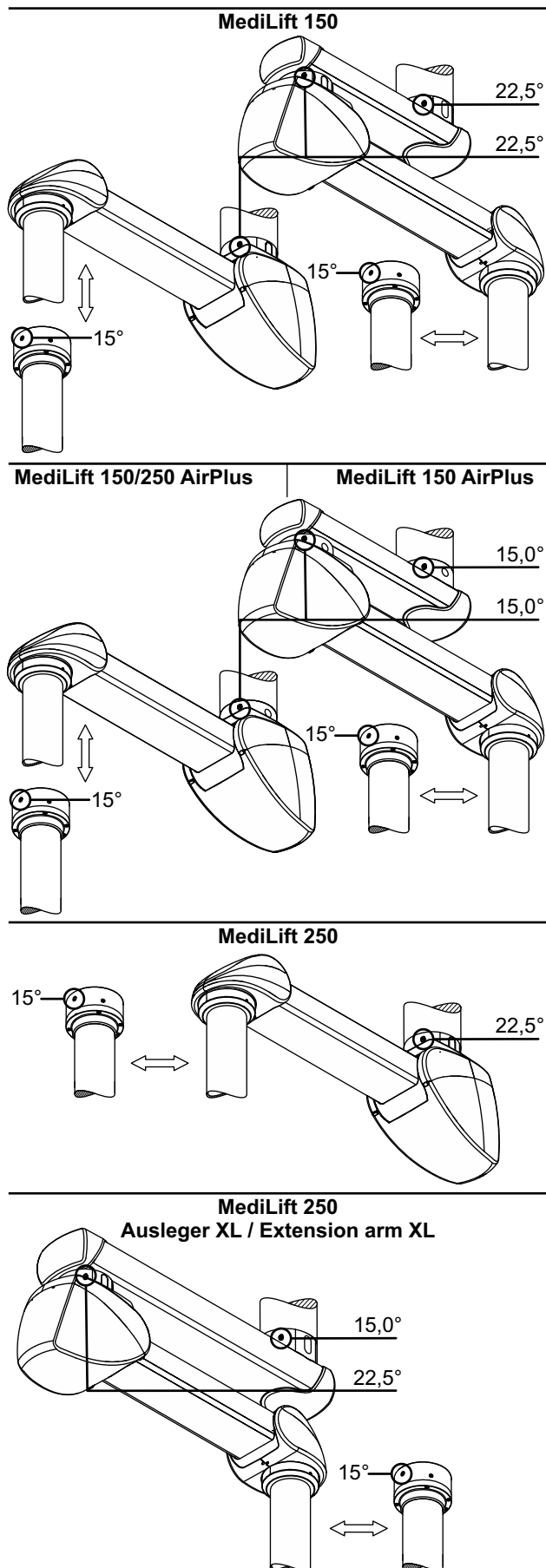

7.7 Adjusting the swivel stop on the extension arm, motor arm and Drop tube

(See Figure 16)

The extension arm, motor arm and the Drop tube are equipped with at least 1 swivel stop which prevents internal cables being destroyed. With 1 ball stop installed, the swivel range is restricted to a maximum of 340 degrees. With 2 ball stops installed, the swivel range can be restricted further.

⚠ WARNING



Electric shock hazard

In order to prevent the internal supply cables twisting off, at least 1 ball stop must be mounted. This individual ball stop serves as twist protection:

- To restrict the angle of rotation of the extension arm, motor arm or Drop tube to 340 degrees, mount at least 1 ball stop as described in Kapitel 7.7.5, Seite 35.

7.7.1 Versions

(See Figure 16)

Proceed as follows in order to adjust the swivel ranges:

Navigator Lift™ 150 / 250

- Adjust the swivel range of the extension arm and motor arm in graduations of 22.5 degrees.
- Use 1 setscrew M16 and 2 ball stops Ø 12.7 mm for each extension arm and motor arm.

Navigator Lift™ 150 / 250 AirPlus and Navigator Lift™ 150 / 250 Friction

- Adjust the swivel range of the extension arm and motor arm in graduations of 15.0 degrees.
- Use 1 setscrew M16 and 2 ball stops Ø 10 mm for each extension arm and motor arm.

Navigator Lift™ XL 250 Dual

- Adjust the swivel range of the extension arm XL in graduations of 15.0 degrees and on the motor arm in graduations of 22.5 degrees.
- For the extension arm use 1 setscrew M20 and 2 ball stops Ø 16 mm.
- For the motor arm use 1 setscrew M16 and 2 ball stops Ø 12.7 mm.

Drop tube with Bearing Unit Friction (roller bearing)

- Adjust the swivel range of the Drop tube in graduations of 15.0 degrees.
- Use 1 setscrew M16 and 2 ball stops Ø 10 mm for each Drop tube.

7.7.2 Tool to be used

A magnetic pin is required in order to offset the ball stop.

The telescopic magnet pick-up tool set is available from Nuvo.

To change a mounted ball stop, refer to Kapitel 7.7.3, "Changing or dismantling the swivel stop", Seite 33.

Figure 17: Changing or dismantling the swivel stop

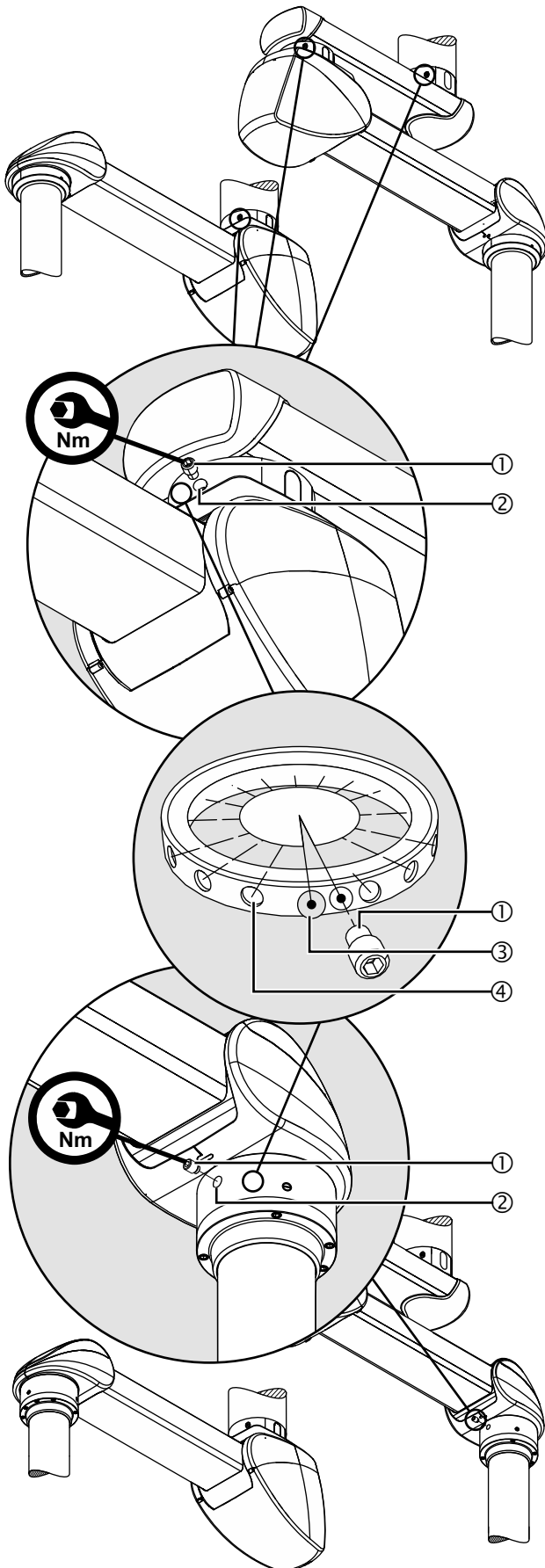

7.7.3 Changing or dismantling the swivel stop

(See Figure 17)

1. Follow the general safety instructions prescribed in Kapitel 7.1, Seite 26.
2. The assignment and size of the setscrew ① and the ball stop ③ for the different versions of the pendant system and the Drop tube are described in Kapitel 7.7.1, "Versions", Seite 32.
3. Unscrew a setscrew ① from the threaded hole ② .
4. Rotate the extension arm, extension arm XL, motor arm or Drop tube until the ball stop ③ in the threaded hole ② is visible.
5. Using a telescopic magnet pick-up tool, remove the ball stop ③ from the threaded hole ② and keep it in a safe place.

⚠ WARNING



Electric shock hazard

In order to prevent the internal supply cables twisting off, at least 1 ball stop must be mounted. This individual ball stop serves as twist protection:

- Mount the swivel stop directly afterwards.
- Mount at least 1 ball stop ③ in order to restrict the angle of rotation of the extension arm, motor arm or Drop tube to 340 degrees.

6. Mount the swivel stop as described in Kapitel 7.7.4, Seite 34 and Kapitel 7.7.5, Seite 35.

Figure 18: Stop recommendation: Dual-arm pendant system with Bearing Unit Friction (roller bearing)

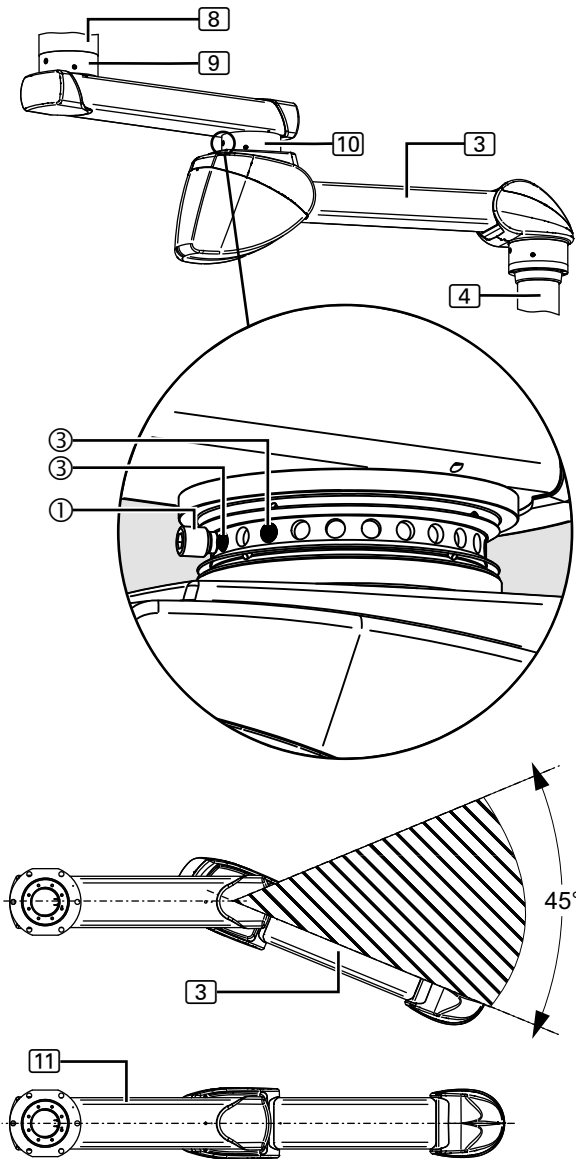

7.7.4 Stop recommendation: Dual-arm pendant system with Bearing Unit Friction (roller bearing)

(See Figure 18)

For all dual-arm pendant systems with a Bearing Unit Friction as intermediate bearing (10), Nuvo recommends that you mount 2 ball stops (3) (position illustrated in the Figure).

The detailed representation illustrates the intermediate bearing (10) (without external bearing ring) and the position of the stop screw (1) to the ball stops (3).

NOTE: Movement range of the motor arm

When adjusting the end stop as illustrated in Figure 18, the dead centre area is 45°. This means that the motor arm (3) has a maximum movement range of approx. 315°.

If the minimum adjustment on the end stop is not defined whereas the brakes on the intermediate bearing (10) and on the ceiling bearing (9), are adjusted, it is rather difficult to bend the pendant system from the stretched position (11) and rotate it on the intermediate bearing (10) of the motor arm (3).

When moving the adaption on the Drop tube (4) from the stretched position (11), there is a risk that the extension arm and the motor arm rotate around the ceiling bearing (9) even though bending in the area of the intermediate bearing (10) would be desired.

For more details on how to mount the swivel stop refer to Kapitel 7.7.5, Seite 35.

Figure 19: Mounting the swivel stop

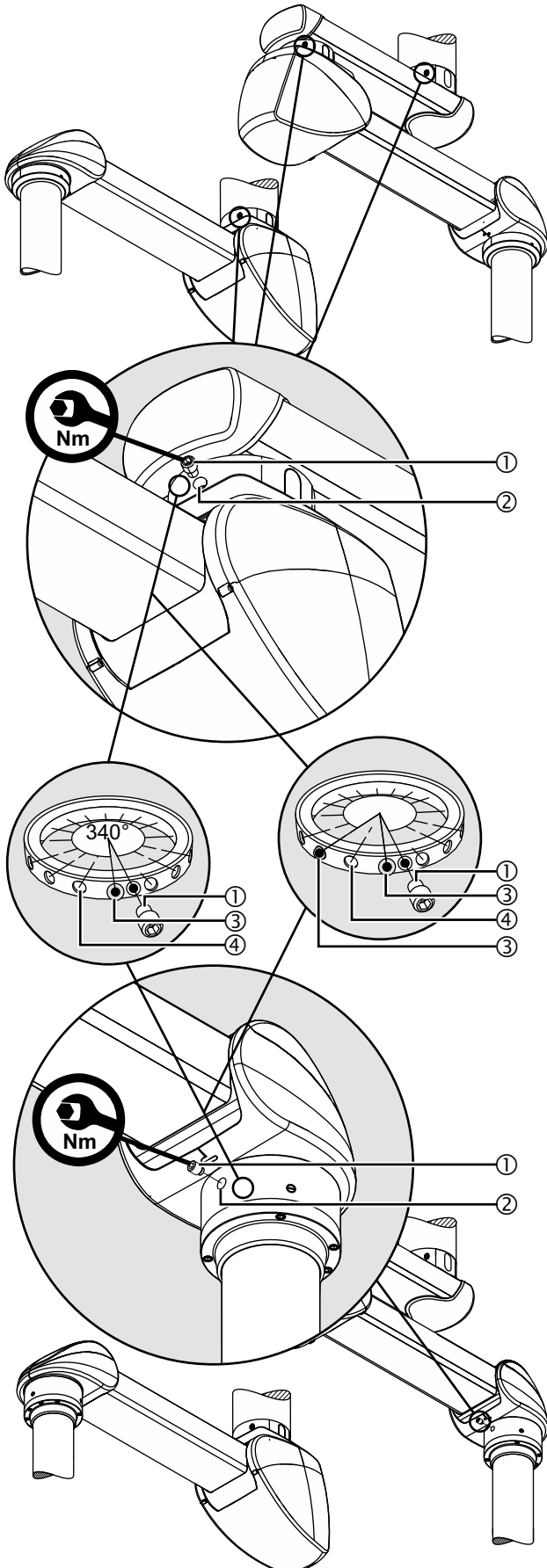

7.7.5 Mounting the swivel stop

(See Figure 19)

1. Follow the general safety instructions prescribed in Kapitel 7.1, Seite 26.
2. The assignment and size of the setscrew ① and the ball stop ③ for the different versions of the pendant system and the Drop tube are described in Kapitel 7.7.1, "Versions", Seite 32.
3. Unscrew a setscrew ① from the threaded hole ② .
4. Rotate the extension arm, extension arm XL, motor arm or Drop tube towards the desired end stop position and then insert 1 ball stop ③ into the threaded hole ② .

NOTE – Make sure that the ball stop is securely in place

The extension arm, motor arm or the Drop tube can be rotated once the ball stop ③ has been completely inserted into one of the mounting fixtures ④ . Otherwise, these are blocked and the ball stop ③ must be pushed into one of the mounting fixtures ④ whilst gently rotating the extension arm, motor arm or Drop tube using a screwdriver.

5. Rotate the extension arm, motor arm or Drop tube towards the desired second end stop position and then insert 1 additional ball stop ③ into the threaded hole ② .
6. Slightly rotate the extension arm, motor arm or Drop tube and then screw the setscrew ① into the threaded hole ② as far as it will go.
 - The setscrew ① now serves as an end stop for the ball stop ③ mounted and restricts the swivel range of the extension arm, motor arm or Drop tube.

⚠ WARNING



Risk of internal supply cables twisting off

The swivel stop can fail if the fixing elements have not been properly tightened, and the supply cables can twist off:

- Tighten the setscrew M16 ① or setscrew M20 ① to 40Nm.

7. Tighten the setscrew ① to 40 Nm.
8. To check that the swivel stop operates securely:
 - The swivel range of the extension arm, motor arm or Drop tube must be restricted to less than 360 degrees.

8.1 General safety instructions

WARNING



Electric shock hazard

The appliances can carry an electric current and must be treated with the utmost care during cleaning and disinfection:

- If a mains plug exists, pull out the mains plug.
- Do not apply spray cleaning and/or spray disinfection.
- Do not spray liquid into power sockets, gas sockets or appliance openings and prevent the penetration of liquids.

8.2 Cleaning

Follow the safety instructions

1. Follow the general safety instructions prescribed in Kapitel 8.1, "General safety instructions", Seite 36.

WARNING

Risk of contamination and infection of the patient

Parts of the pendant system and the adaptations are made of plastic. Solvents can dissolve plastic materials. Strong acids, bases and agents with an alcoholic strength of more than 60 % can lead to the plastic materials becoming brittle. Detached particles can fall into open wounds. If liquid cleaning agents are allowed to penetrate the pendant system and the adaptations, excess cleaning liquid may drip into open wounds.

Cleaning agents

Recommended cleaning agents

Use a mild soap solution or a regular dishwashing product.

2. Wipe the surfaces of the appliances with a moderately moist cloth; add a mild soap solution (dishwashing product) if required.
3. Afterwards, carefully wipe the surfaces dry with a clean cloth.

8.3 Disinfection

Follow the safety instructions

1. Follow the general safety instructions prescribed in Kapitel 8.1, "General safety instructions", Seite 36.

WARNING

The appliance is not suitable for sterilisation

Avoid damage

- Make sure that no liquid penetrates the appliance whilst cleaning it.
- To prevent damage to plastic parts, refrain from using abrasives or alkaline, acidic or corrosive cleaning agents.
- Do not use bleaching agents on stainless steel parts.

Deploy trained technical specialists only and abide by national regulations.

- Cleaning/disinfection must be carried out by trained technical specialists only. The requirements of the national hygiene and disinfection committee must be complied with.

CAUTION

Health hazard

Disinfectants can contain substances hazardous to health which, when in contact with the skin and eyes, can cause injuries or affect the respiratory organs when inhaled. Observe the protective measures:

- Observe the hygiene regulations.
- Adhere to the disinfectant manufacturer's instructions.
- Perform surface disinfection every working day and in case of contamination.

Disinfection method	<p>Wiping disinfection is the standardised disinfection method prescribed for the pendant system. Hygiene regulations and related safety instructions for the disinfection methods to be applied must be defined by the operator.</p> <ul style="list-style-type: none"> • In case of contamination with potentially infectious material (e.g. blood, body secretion or excrement) the surfaces must be immediately and specifically disinfected. • Make sure you apply the disinfectant in the correct concentration. • For surface disinfection do not spray, but wipe, the surfaces. • Wiped surfaces may only be used after the disinfectant has dried.
---------------------	---

9.1 General safety instructions

⚠ WARNING



Electric shock hazard

Power supply cables are laid in the pendant system and in the Navigator M6. Contact with energised components presents a danger to life from electric shock. Disconnect the pendant system from the mains before any maintenance work:

- Disconnect all the poles of the pendant system and the Navigator M6 from the mains and prevent them from being reconnected.
- Make sure that all the appliances connected via the Navigator M6 are de-energised.
- Wait until the end device (e.g. HF surgical device, flat screen, etc.) has cooled down.

The necessary maintenance work must be carried out as specified in Chapter 17, "Inspection plan", on page 89.

Third-party manufacturers

9.2 Built-in components from third-party manufacturers

Built-in components from third-party manufacturers must be inspected and maintained as prescribed in the applicable Operating Instructions.

9.3 Repeated inspection

The repeated inspection must be performed in accordance with DIN EN 62353 standard.

10 Disposal of the Pendant System



10.1 Disposal

- The pendant system complies with the requirements of the 2011/65/EC RoHS Directive (on the restricted use of certain hazardous substances in electrical and electronic equipment).
- To prevent environmental damage and personal injury, we request you to contact us or your authorised service partner if you intend to take the pendant system out of operation for the purpose of disposal.
- The pendant system must be disposed of at a suitable collection point for recyclable waste in accordance with country-specific regulations.

10.2 List of the materials used for the pendant system Technical

Component	Materials used
Package	Cardboard packaging, paper, wood, metal, plastics
Mechanical load-carrying parts	Metal
Cover panels	Plastics
Cables	Metal, plastics

Figure 20: Motor arm Navigator Lift™ 150 / 250, Navigator Lift™ 150 / 250 Friction – Single-arm variant with Navigator M6

The Figure illustrates the extension arm with motor arm Navigator Lift™ 150 / 250 with Navigator M6 as an example. Please note that your individual pendant system configuration can differ from the illustration. The round canopy can only be mounted with the round interface plate. The rectangular canopy 700 x 700mm can only be mounted with the rectangular interface plate.

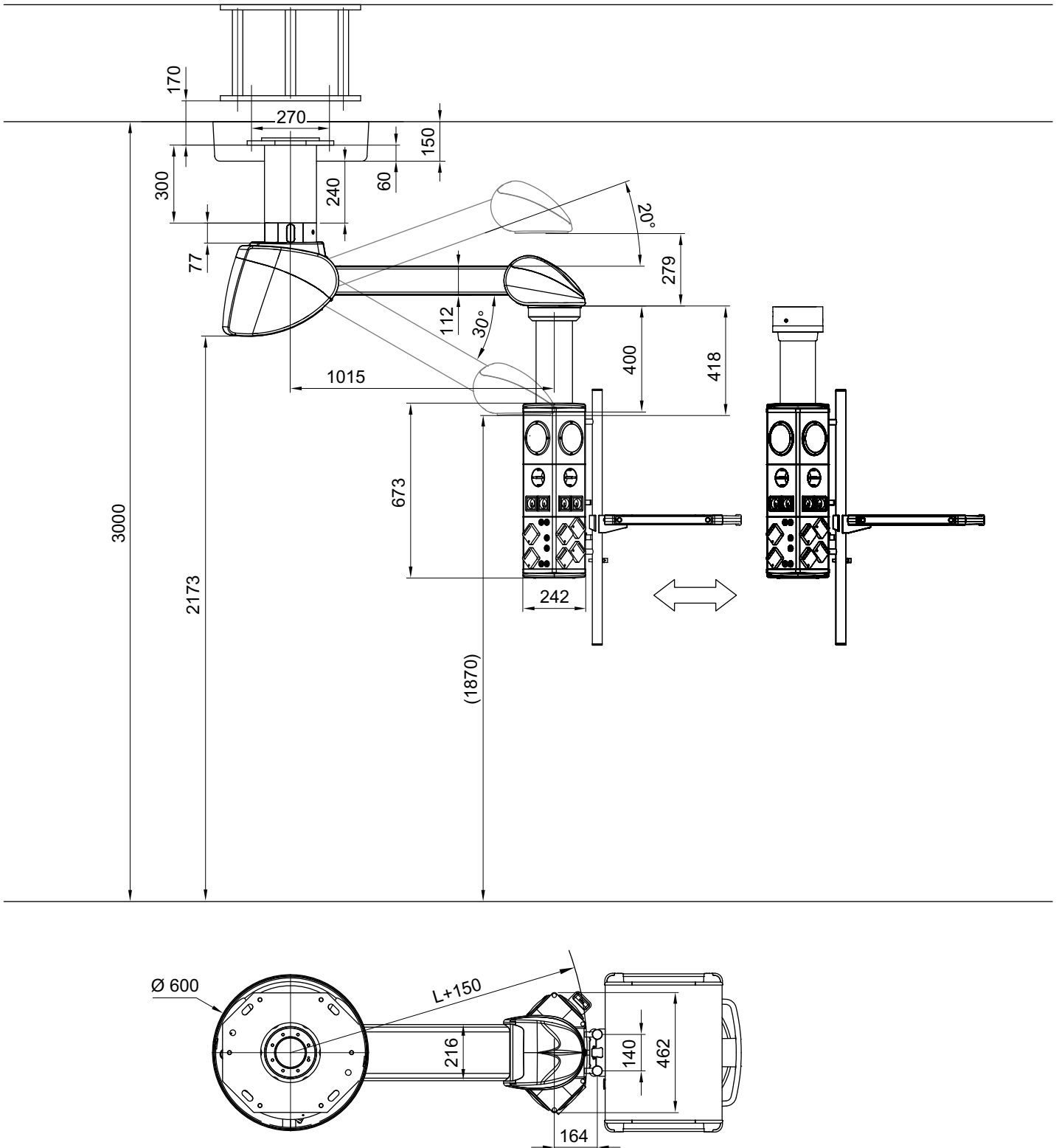

Figure 21: Extension arm with motor arm Navigator Lift™ 150, Navigator Lift™ 150 Friction - Dual-arm variant with Navigator M6

The Figure illustrates the extension arm with motor arm Navigator Lift™ 150 with Navigator M6 as an example. Please note that your individual pendant system configuration can differ from the illustration. *The maximum extension arm length of the variant: extension arm with motor arm Navigator Lift™ 150 Friction is 1000 mm. The round canopy can only be mounted with the round interface plate. The rectangular canopy 700 x 700mm can only be mounted with the rectangular interface plate.

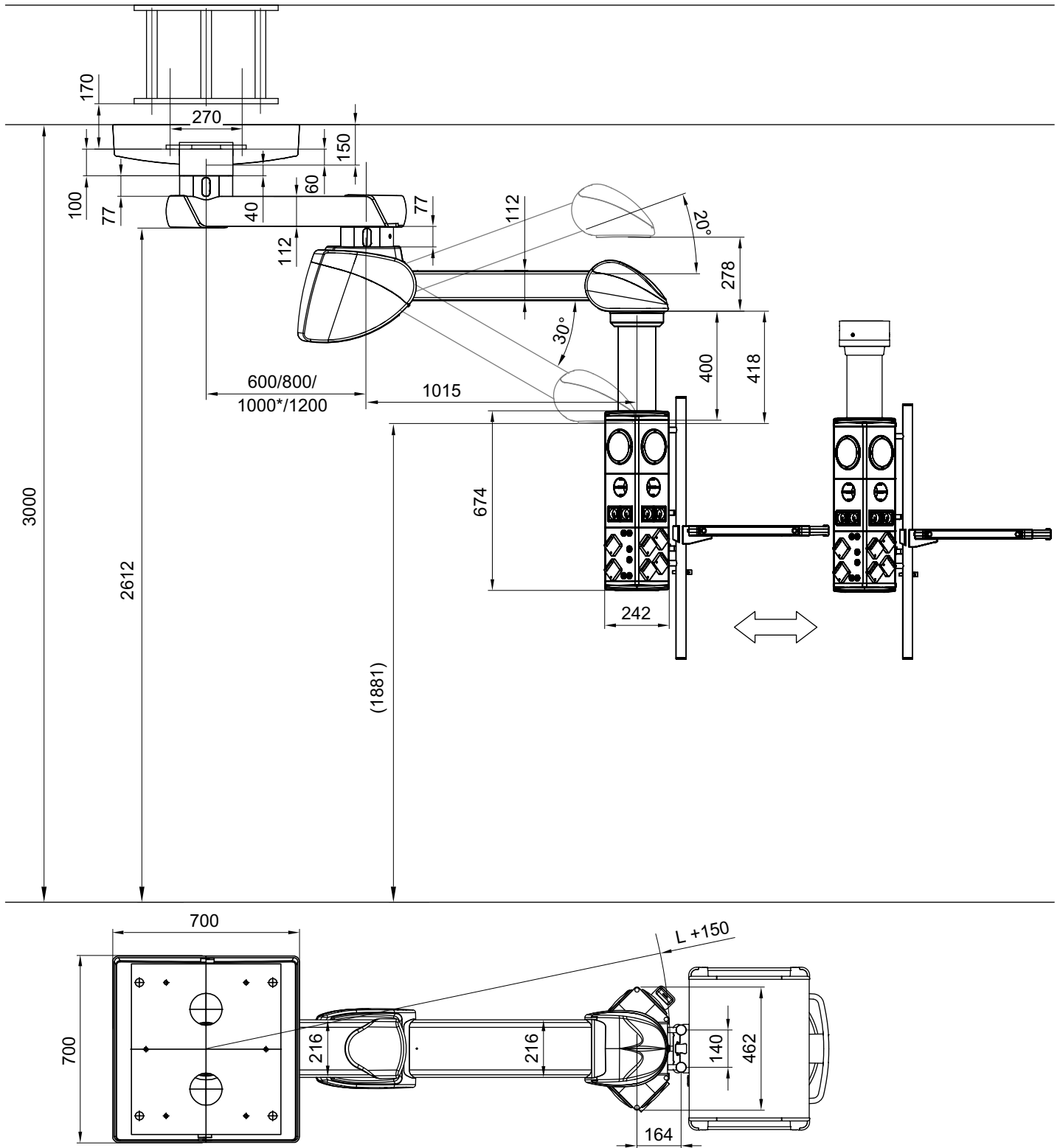
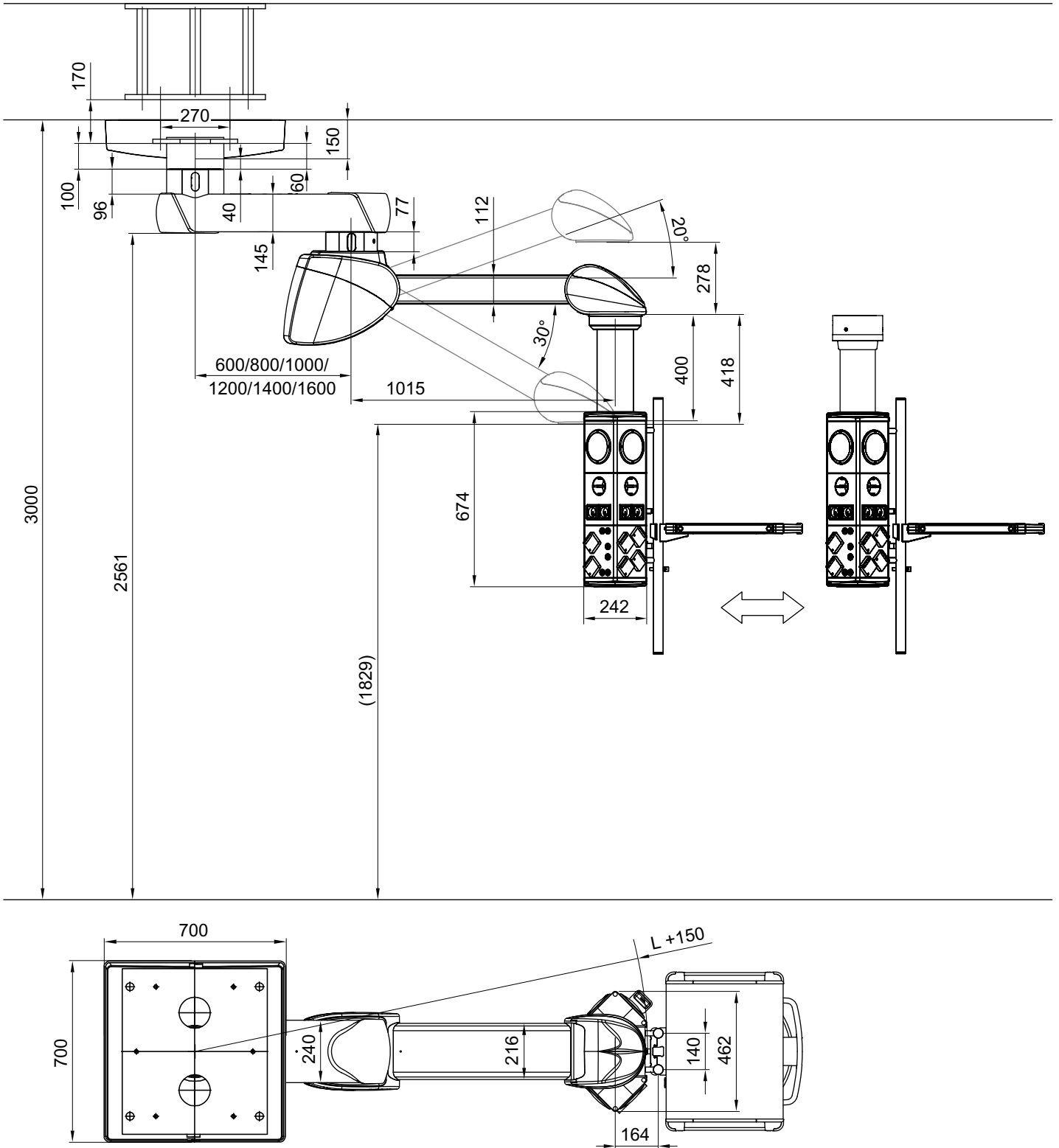

Figure 22: Extension arm XL with motor arm Navigator Lift™ XL 250 Dual - Dual-arm variant with Navigator M6

The Figure illustrates the extension arm XL with motor arm Navigator Lift™ XL 250 Dual with Navigator M6 as an example. Please note that your individual pendant system configuration can differ from these illustrations. The round canopy can only be mounted with the round interface plate. The rectangular canopy 700 x 700mm can only be mounted with the rectangular interface plate.



Modes of operation	<ul style="list-style-type: none"> • The pendant systems Navigator Lift™ 150 Single, Navigator Lift™ 150 Friction Single, Navigator Lift™ 150 Friction Dual, Navigator Lift™ 250 Friction Single, Navigator Lift™ 250 AirPlus Single, Navigator Lift™ 250 Single, Navigator Lift™ 250 AirPlus Single, Navigator Lift™ 150 Dual, Navigator Lift™ 150 AirPlus Dual, Navigator Lift™ XL 250 Dual are suitable for continuous operation. 																						
Duty cycle of the height adjustment mechanism	<ul style="list-style-type: none"> • The maximum duty cycle of the height adjustment mechanism on the motor arm must not exceed 3 minutes. – If the height adjustment mechanism is actuated over a longer period of time, the electric motor of the motor arm may switch off automatically as a protection measure against overheating. – In order to prevent an overload of the electric motor, make sure you wait at least 30 minutes after actuating the height adjustment mechanism before putting the height adjustment mechanism into operation. Afterwards the height adjustment mechanism can be operated once again for 3 minutes. 																						
Duty cycle of the electromagnetic brakes	<ul style="list-style-type: none"> • The maximum duty cycle of the electromagnetic brakes must not exceed 1 minute: – If the electromagnetic brakes are actuated over a longer period of time, the power pack may switch off automatically as a protection measure against overheating. – Once the power pack has switched off, it must cool down for 10 minutes and then be disconnected from the mains for 10 seconds before being switched back on again. Normal system operation can only be resumed afterwards. 																						
Rating plate	<ul style="list-style-type: none"> • The rating plates are attached to the top side of the extension arm or XL extension arm and under the front cover of the motor arm (see Kapitel 2.4, Seite 18). 																						
Dead weight of the pendant system*	<table border="0" style="width: 100%;"> <tr> <td>Motor arm 150 / 250 (1015 mm long).....</td> <td style="text-align: right;">58kg</td> </tr> <tr> <td>Extension arm, 600mm, with motor arm 150 (1015 mm long).....</td> <td style="text-align: right;">83kg</td> </tr> <tr> <td>Extension arm, 800mm, with motor arm 150 (1015 mm long).....</td> <td style="text-align: right;">86kg</td> </tr> <tr> <td>Extension arm, 1000mm, with motor arm 150 (1015 mm long).....</td> <td style="text-align: right;">89kg</td> </tr> <tr> <td>Extension arm, 1200mm, with motor arm 150 (1015 mm long).....</td> <td style="text-align: right;">92kg</td> </tr> <tr> <td>XL extension arm, 600mm, with motor arm 250 (1015 mm long).....</td> <td style="text-align: right;">99kg</td> </tr> <tr> <td>XL extension arm, 800mm, with motor arm 250 (1015 mm long).....</td> <td style="text-align: right;">104kg</td> </tr> <tr> <td>XL extension arm, 1000mm, with motor arm 250 (1015 mm long).....</td> <td style="text-align: right;">109kg</td> </tr> <tr> <td>XL extension arm, 1200mm, with motor arm 250 (1015 mm long).....</td> <td style="text-align: right;">114kg</td> </tr> <tr> <td>XL extension arm, 1400mm, with motor arm 250 (1015 mm long).....</td> <td style="text-align: right;">119kg</td> </tr> <tr> <td>XL extension arm, 1600mm, with motor arm 250 (1015 mm long).....</td> <td style="text-align: right;">124kg</td> </tr> </table> <p>* Without gas hoses and supply cables inserted, without ceiling or Drop tube and without optional accessories.</p>	Motor arm 150 / 250 (1015 mm long).....	58kg	Extension arm, 600mm, with motor arm 150 (1015 mm long).....	83kg	Extension arm, 800mm, with motor arm 150 (1015 mm long).....	86kg	Extension arm, 1000mm, with motor arm 150 (1015 mm long).....	89kg	Extension arm, 1200mm, with motor arm 150 (1015 mm long).....	92kg	XL extension arm, 600mm, with motor arm 250 (1015 mm long).....	99kg	XL extension arm, 800mm, with motor arm 250 (1015 mm long).....	104kg	XL extension arm, 1000mm, with motor arm 250 (1015 mm long).....	109kg	XL extension arm, 1200mm, with motor arm 250 (1015 mm long).....	114kg	XL extension arm, 1400mm, with motor arm 250 (1015 mm long).....	119kg	XL extension arm, 1600mm, with motor arm 250 (1015 mm long).....	124kg
Motor arm 150 / 250 (1015 mm long).....	58kg																						
Extension arm, 600mm, with motor arm 150 (1015 mm long).....	83kg																						
Extension arm, 800mm, with motor arm 150 (1015 mm long).....	86kg																						
Extension arm, 1000mm, with motor arm 150 (1015 mm long).....	89kg																						
Extension arm, 1200mm, with motor arm 150 (1015 mm long).....	92kg																						
XL extension arm, 600mm, with motor arm 250 (1015 mm long).....	99kg																						
XL extension arm, 800mm, with motor arm 250 (1015 mm long).....	104kg																						
XL extension arm, 1000mm, with motor arm 250 (1015 mm long).....	109kg																						
XL extension arm, 1200mm, with motor arm 250 (1015 mm long).....	114kg																						
XL extension arm, 1400mm, with motor arm 250 (1015 mm long).....	119kg																						
XL extension arm, 1600mm, with motor arm 250 (1015 mm long).....	124kg																						
Dead weight of the ceiling tube for the extension arm	<table border="0" style="width: 100%;"> <tr> <td>Flange</td> <td style="text-align: right;">6kg</td> </tr> <tr> <td>Steel tube</td> <td style="text-align: right;">24kg/m</td> </tr> </table>	Flange	6kg	Steel tube	24kg/m																		
Flange	6kg																						
Steel tube	24kg/m																						
Dead weight of the ceiling tube for the XL extension arm	<table border="0" style="width: 100%;"> <tr> <td>Flange</td> <td style="text-align: right;">7.5kg</td> </tr> <tr> <td>Steel tube</td> <td style="text-align: right;">31.7kg/m</td> </tr> </table>	Flange	7.5kg	Steel tube	31.7kg/m																		
Flange	7.5kg																						
Steel tube	31.7kg/m																						
Dead weights of the bearing units on the Drop tube	<table border="0" style="width: 100%;"> <tr> <td>Bearing Unit Friction (slide bearing).....</td> <td style="text-align: right;">5kg</td> </tr> <tr> <td>Bearing Unit Friction (roller bearing)</td> <td style="text-align: right;">13kg</td> </tr> <tr> <td>Bearing Unit E-Brake</td> <td style="text-align: right;">14kg</td> </tr> </table>	Bearing Unit Friction (slide bearing).....	5kg	Bearing Unit Friction (roller bearing)	13kg	Bearing Unit E-Brake	14kg																
Bearing Unit Friction (slide bearing).....	5kg																						
Bearing Unit Friction (roller bearing)	13kg																						
Bearing Unit E-Brake	14kg																						
Dead weight of the Drop tube	<table border="0" style="width: 100%;"> <tr> <td>Drop tube</td> <td style="text-align: right;">8kg/m</td> </tr> </table>	Drop tube	8kg/m																				
Drop tube	8kg/m																						

Maximum loading capacity on the pendant system	Motor arm 150 (1015 mm long) 150kg Motor arm 250 (1015 mm long) 250kg Extension arm, 600mm, with motor arm 150 (1015 mm long)..... 150kg Extension arm, 800mm, with motor arm 150 (1015 mm long)..... 150kg Extension arm, 1000mm, with motor arm 150 (1015 mm long)..... 150kg Extension arm, 1200mm, with motor arm 150 (1015 mm long)..... 140kg XL extension arm, 600mm, with motor arm 250 (1015 mm long)..... 250kg XL extension arm, 800mm, with motor arm 250 (1015 mm long)..... 250kg XL extension arm, 1000mm, with motor arm 250 (1015 mm long)..... 250kg XL extension arm, 1200mm, with motor arm 250 (1015 mm long)..... 250kg XL extension arm, 1400mm, with motor arm 250 (1015 mm long)..... 240kg XL extension arm, 1600mm, with motor arm 250 (1015 mm long)..... 200kg
Electrical data	Rated voltage.....AC 100V-120V and AC 220V-240V Rated frequency 60 / 50Hz Rated current at AC 100V-120V 10A Rated current at AC 220V-240V 5A Indirect extension arm lighting DC 12V 2 / 4 lighting boards (supply voltage 12V DC, 2 lighting boards each connected in series to 24V DC)
Noise level	Sound energy level65db(A) (EN ISO 3746) not exceeded
Brake torque	Brake torque with the pneumatic brake actuated approx. 50Nm Brake torque with the electromagnetic brake actuated on the motor arm ... approx. 70Nm Brake torque with the electromagnetic brake actuated on the extension arm and motor armapprox. 70Nm / approx. 70Nm Brake torque with the electromagnetic brake actuated on the XL extension arm and motor arm approx. 150Nm / approx. 70Nm
Manual forces	Dynamic torque with the electromagnetic brake released depending on the position and payload 3.5 to 40Nm
Protection class / type	Protection class in accordance with IEC 60601-1..... I IP classification in accordance with IEC 60529 IP 20
Medical Device Directive 93/42/EEC	Classification..... I
Applicable standards, laws and directives	<ul style="list-style-type: none"> • Medical Devices Act (MPG) • 93/42 EEC (Medical Device Directive) • IEC 60601-1 – Medical Electrical Equipment – Part 1: General Requirements for Basic Safety and Essential Performance.
Approvals of the standard equipment	<ul style="list-style-type: none"> • Recognised NRTL component.

Approved adaptations	<p>The following Nuvo products are approved as adaptations to the pendant system:</p> <ul style="list-style-type: none">• Kapitel 14, "Approved Nuvo Products", Seite 50,• Kapitel 15, "Optional Accessories", Seite 50,• Kapitel 16, "Possible Combination with Third-Party Products", Seite 50;– The components are adapted to each other and safe to operate. Any other type of installation, and in particular the use of components from third-party manufacturers, is strictly prohibited because these components can be potential sources of danger.– The combination of any other Nuvo product with the pendant system must be approved by Nuvo Surgical. If applicable, the conformity assessment must be repeated.
Read the Operating Instructions for combined medical products	<ul style="list-style-type: none">• The pendant system can be equipped with adaptations and end devices of third-party manufacturers. To prevent dangerous overload, which can damage or lead to a collapse of the pendant system, the maximum load bearing capacity specified in Kapitel 12, "Technical Data", Seite 42 must be adhered to:– The party placing the appliance into operation is responsible for the validation of the overall system. A conformity assessment procedure shall be executed if required and a declaration in accordance with Article 12 of 93/42/EEC (Medical Device Directive, MDD) shall be provided.– Read the Operating Instructions provided by the third-party manufacturer and in particular the relevant pages with information on the operation of the end device.

13.1 Guidelines and manufacturer's declarations

13.1.1 Electromagnetic emissions

The Navigator Lift™ 150 / 250 is intended for use in the ELECTROMAGNETIC ENVIRONMENT specified below. The customer or the user of the Navigator Lift™ 150 / 250 must ensure that it is used in such an environment.

Emission tests	Compliance	ELECTROMAGNETIC ENVIRONMENT – Guideline
RF emissions in accordance with CISPR 11	Group 1	The Navigator Lift™ 150 / 250 uses RF energy only for its internal FUNCTIONING. Therefore, its RF emissions are very low and are not likely to cause any interference with electronic equipment nearby.
RF emissions in accordance with CISPR 11	Class A	The Navigator Lift™ 150 / 250 is suitable for operation in professional healthcare facilities.
Harmonic emissions in accordance with IEC 61000-3-2	Class A	
Voltage fluctuations/flicker emissions in accordance with IEC 61000-3-3	Complies	

13.1.2 Electromagnetic immunity

The Navigator Lift™ 150 / 250 is intended for use in the ELECTROMAGNETIC environment specified below. The customer or the user of the Navigator Lift™ 150 / 250 should ensure that it is used in such an environment.

Interference immunity test	Test level in accordance with IEC 60601	Test result
Electrostatic discharge in accordance with IEC 61000-4-2	±8kV contact ±2kV, ±4kV, ±8kV, ±15kV air	passed
Electrical fast transients / bursts in accordance with IEC 61000-4-4	±2kV 100kHz repetition rate	passed
Surges Line-to-line in accordance with IEC 61000-4-5	±0.5kV, ±1kV	passed
Surges Line-to-earth in accordance with IEC 61000-4-5	±0.5kV, ±1kV, ±2kV	passed
Voltage dips in accordance with IEC 61000-4-11	0% U_T ; 1/2 period at 0, 45, 90, 135, 180, 225, 270 and 315 degrees	passed
	0% U_T ; 1 period and 70% U_T ; 25/30 periods Single phase: at 0 degrees	passed
Voltage interruptions in accordance with IEC 61000-4-11	0% U_T ; 250/300 periods	passed
Power frequency magnetic field immunity in accordance with IEC 61000-4-8	30A/m	passed
	50Hz or 60Hz	

Please note:

U_T is the a.c. mains voltage prior to application of the test level.

Cont.

The Navigator Lift™ 150 / 250 is intended for use in the ELECTROMAGNETIC environment specified below. The customer or the user of the Navigator Lift™ 150 / 250 should ensure that it is used in such an environment.

Interference immunity test	Test level in accordance with IEC 60601	Compliance level
Immunity to conducted disturbances, induced by radiofrequency fields IEC 61000-4-6	3V 0.15MHz to 80MHz 6V in ISM frequency bands from 0.15MHz to 80MHz 80% AM at 1kHz	passed
High-frequency electromagnetic fields in accordance with IEC 61000-4-3	3V/m 80MHz to 2.7GHz 80% AM at 1kHz	passed
<p>NOTE 1 At 80 MHz and 800 MHz, the higher value applies.</p> <p>NOTE 2 These guidelines may not apply in all cases. Electromagnetic propagation is affected by absorption and reflection from structures, objects and people.</p> <p>^a The field strength of stationary transmitters, including the base stations of mobile phones and mobile land mobile radios, amateur radio stations, AM and FM radio and TV broadcasting transmitters, cannot be precisely predetermined theoretically. To assess the electromagnetic environment due to stationary RF transmitters, an electromagnetic site survey should be considered. If the field strength measured in the location in which the Navigator Lift™ 150 / 250 is used exceeds the applicable RF compliance level above, the Navigator Lift™ 150 / 250 should be observed to verify normal operation. If abnormal performance is observed, additional measures may be necessary, such as re-orienting or relocating the Navigator Lift™ 150 / 250.</p> <p>^b Field strengths over the 150 kHz to 80 MHz frequency range should be less than 3 V/m.</p>		

13.1.3 Test specifications

Test specifications for the INTERFERENCE IMMUNITY of ENCLOSURES against high-frequency wireless communication facilities

Test frequency MHz	Frequency band ^a MHz	Radio service ^a	Modulation ^b	Maximum power W	Distance m	IMMUNITY TEST LEVEL V/m
385	380 to 390	TETRA 400	Pulse modulation ^b 18Hz	1.8	0.3	27
450	430 to 470	GMRS 460, FRS 460	FM ^c ± 5kHz stroke 1kHz sine	2	0.3	28
710	704 to 787	LTE Band 13, 17	Pulse modulation ^b 217Hz	0.2	0.3	9
745						
780						
810	800 to 960	GSM 800/900, TETRA 800, iDEN 820, CDMA 850, LTE Band 5	Pulse modulation ^b 18Hz	2	0.3	28
870						
930						
1720	1700 to 1998	GSM 1800; CDMA 1900; GSM 1900; DECT; LTE Band 1, 3, 4, 25; UMTS	Pulse modulation ^b 217Hz	2	0.3	28
1845						
1970						
2450	2400 to 2570	Bluetooth, WLAN 802.11 b/g/n, RFID 2450, LTE Band 7	Pulse modulation ^b 217Hz	2	0.3	28
5240	5100 to 5800	WLAN 802.11 a/n	Pulse modulation ^b 217Hz	0.2	0.3	9
5500						
5785						

NOTE

To reach the IMMUNITY TEST LEVELS, the distance between the transmitting antenna and the ME DEVICE or ME SYSTEM can be reduced to 1m if required. The 1 m test distance is permitted in accordance with IEC 61000-4-3.

^a For certain radio services only the frequencies for the radio connection from the mobile communication device to the base station (“up-link”) are indicated in the table.

^b The carrier must be modulated with a square wave signal with a 50% duty cycle.

^c As an alternative to frequency modulation (FM), pulse modulation with a 50% duty cycle at 18Hz can be used because pulse modulation would also represent the worst case (but not the actual modulation).

⚠ WARNING

Do not operate this device immediately next to or together with other devices stacked on top of each other because this could result in improper operation. If operation in the described manner is unavoidable, this device and all other devices should be monitored in order to ensure proper operation."

⚠ WARNING

The use of other ACCESSORIES, other converters and other cables than those prescribed or provided by the MANUFACTURER of this device can lead to increased ELECTROMAGNETIC INTERFERENCE EMISSIONS or reduced electromagnetic immunity of the device, and thus improper operation.

⚠ WARNING

PORTABLE RF communication devices (radio equipment, including ACCESSORIES such as antenna cables and external antennas) should not be used at a distance of less than 30cm (12inches) from the Navigator Lift™ 150 / 250 components and cables specified by the MANUFACTURER. Be aware that the performance of the device can be reduced if this safety rule is not observed.

Designation
Navigator M6 and approved end devices in accordance with the current Operating Instructions of the Navigator M6.

15 Optional Accessories

Designation	Dead weight	Maximum payload
Indirect extension arm lighting	2.0 kg	---
Brake indicator lighting board	0.1 kg	---
Adapter Acrobat Swing 3p, L360*	2,2kg	10kg / 113Nm
<p>* The accessories can only be used if the extension arm has been supplied with preparation for adapter. This option can be selected for the dual-arm variant on the upper extension arm: Navigator™ in lengths of 800mm and 1000mm Navigator™ XL in lengths of 1000mm and 1200mm</p>		

16 Possible Combination with Third-Party Products

Approved third-party products with CE mark
<p>For more detailed information on the requirements for the interface towards the pendant system please contact Nuvo customer service so as to prevent damage to persons or property: Phone: +1 (800) 663-1152 (USA and CANADA) Phone: +1 (814) 899-4220 (INTERNATIONAL)</p>
<p>The party placing the appliance into operation is responsible for the validation of the overall system. A conformity assessment procedure shall be executed if required and a declaration in accordance with Article 12 of 93/42/EEC (Medical Device Directive, MDD) shall be provided.</p>

17 Inspection plan

System Data

Supplier: _____ ART CODE: _____
 _____ Date of installation: _____
 _____ Nuvo serial no.: _____
 _____ Operator's ident no.: _____
 _____ Device location: _____

Important information

• This installation plan is only valid when combined with the Nuvo Installation and Operating Instructions which must be consulted as complementary reference documents.

The pendant system must be checked by Nuvo or a company authorised by Nuvo for the following points below:

Visual inspection (annually)	n/a	NOK	OK
• The parts of the pendant system are not deformed and are free from damage (scratches, cracks, etc.)*			
• The pendant system is free from defects in paintwork*			
• The covers are available and correctly positioned*	<input type="checkbox"/>		
• All ratings plates and labels are available and readable			
• All the plastic screws of the canopy are available and fixedly attached	<input type="checkbox"/>		
• All cables and gas hoses must be inspected for damage and replaced if required**. Nuvo recommends that you replace cables and gas hoses after 10 years.	<input type="checkbox"/>		
Functional check (annually)	n/a	NOK	OK
• The pendant system is safely positioned; adjust the swivel stops if required			
• At least 1 swivel stop is set at each centre of rotation, properly attached and effective**			
• After releasing the pneumatic brake or electromagnetic brake, the extension arms can be conveniently positioned			
• The brake valves have been vented & close properly; the brake buttons operate smoothly***			
• The mechanical brakes (friction brakes) have been adjusted properly; re-adjust them if required	<input type="checkbox"/>		
• The pendant system remains in any selected position**			
• All sockets (if existing) have been fixedly mounted and function properly**	<input type="checkbox"/>		
• Protective conductor resistance checked** (DIN EN 62353)			
• The screw type connections, with the torques specified in the Installation Instructions, are securely in place			
• The gas sockets (if existing) have been fixedly mounted and function properly**	<input type="checkbox"/>		
• Inspection of the gas hoses/sockets (if exist.) by an authorised body with regard to the gas type/gas density**			
• The motor-driven height adjustment mechanism runs smoothly along the defined travel path**	<input type="checkbox"/>		
• The upper limit stop functions and has been adjusted properly; re-adjust it if required**			
• The lower limit stop functions and has been adjusted properly; re-adjust it if required**			
• Trapez. spindle running freely, operating smoothly&sufficiently lubric.; re-lubricate if required*			
• The BrakeGuides (optional) light up when pressing the corresponding brake button*	<input type="checkbox"/>		
• The extension arm lighting (optional) lights up when actuating the switch (on the Navigator M6)**	<input type="checkbox"/>		

Remarks

Confirmation of the installation

The work mentioned above has been executed, including the adjustments required and the safety test:

Date
Name (in block letters)
Signature/Stamp

* Damaged, deformed or missing components must be replaced as a precaution. In this case, contact the supplier of the pendant system.
 ** If one of the points mentioned above is found to be non-compliant during the inspection, the pendant system must be placed out of operation immediately as a precaution in order to prevent further damage to persons and equipment. Notify the system supplier immediately.
 ***Only applies to Navigator Lift™ 150 / 250 AirPlus

The Medical Product Book which belongs to the medical product in accordance with Medical Devices Operators Ordinance (MPBetreibV) must be available on site. Service and maintenance work and security checks must be documented in this Medical Product Book. Test reports, including this report, must be filed out in the corresponding Medical Product Book.







MedicalIllumination

547 Library St
San Fernando, CA 91340 USA
(818) 838-3025

No. 1568914