

VistOR MS

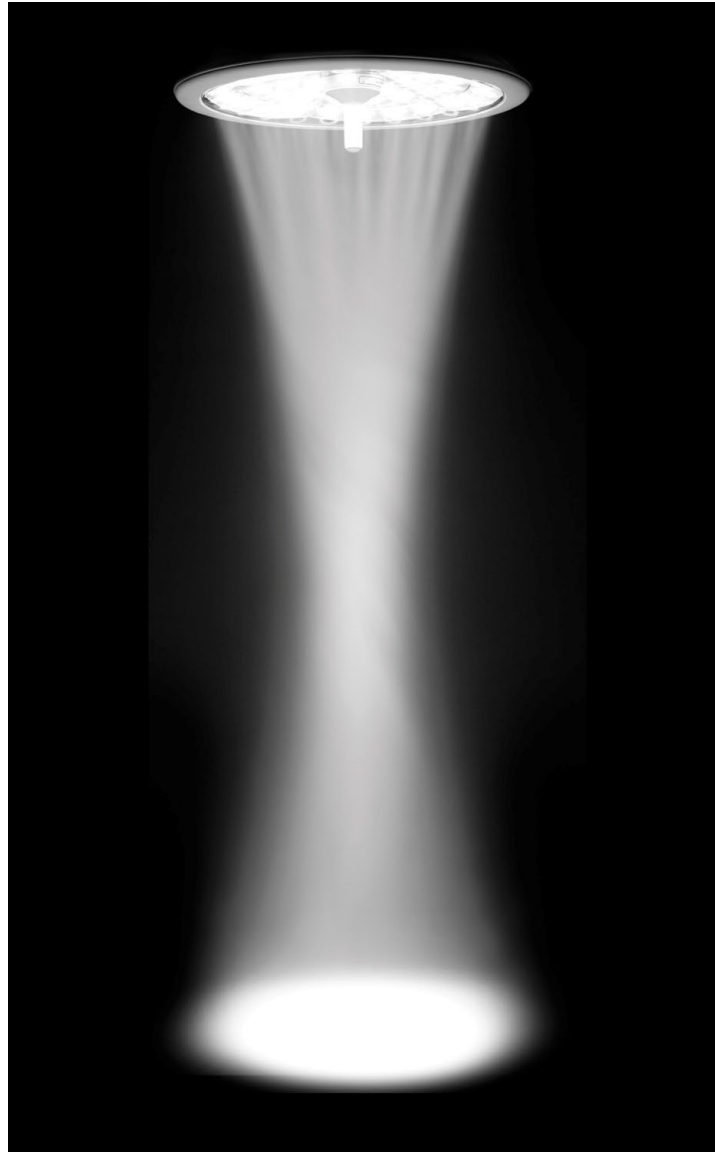

SURGICAL LIGHTING SYSTEM



**INSTALLATION AND
SERVICE MANUAL**



**VistOR MS LED
Agency Approvals**



**Intertek
4010716**

Medical Electrical Equipment
With respect to electric shock, fire
And mechanical hazards only
In accordance with IEC60601-1:2006/CAN/CSA C22.2
No.601.1-M90 with updates 1 & 2

Classifications:

1. Protection against electrical shock (5.1, 5.2). Class I permanently connected,
2. Protection against harmful ingress of water (5.3). None.
3. Degree of safety in the presence of flammable anesthetics or oxygen (5.5). Not suitable for use in the presence of flammable anesthetics or oxygen.
4. Mode of operation (5.6). Continuous
5. Surgical luminaries (IEC60601-2-41)



Electromagnetic compatibility for immunity
And emissions in accordance with
IEC/EN 60601-1-2:2007 edition 3.0 (with 1:2008+A2:2009) and
CISPR 11 Class A

Medical Electrical Equipment
Particular requirements for the safety of surgical
luminaries and luminaries for diagnosis
In accordance with IEC-60601-2-41

Intended use: Professional Medical Lighting for Hospital, Clinic, Minor Surgery, Examination or Diagnosis, within suitable facilities designated for such purposes. This light system is mounted centrally in a room such that access is available all around the operating environment.

User interface: The VistOR MS LED lighting systems are intended to be used by medical professionals in surgeries and exam rooms. The functional interfaces are 360° positioning horizontally and vertically +15° to -65°. The light head can be rotated continuously. An ON/OFF button is provided with 5 levels of dimming and Endo mode.

Misuses: For any purpose or use at any facility other than stated above. Caution shall be exercised when positioning the light head and avoid contact or collision with the patient, other medical professionals or other lights/equipment.

Cautions: Do not apply excessive force to motion range stop features.

Versions

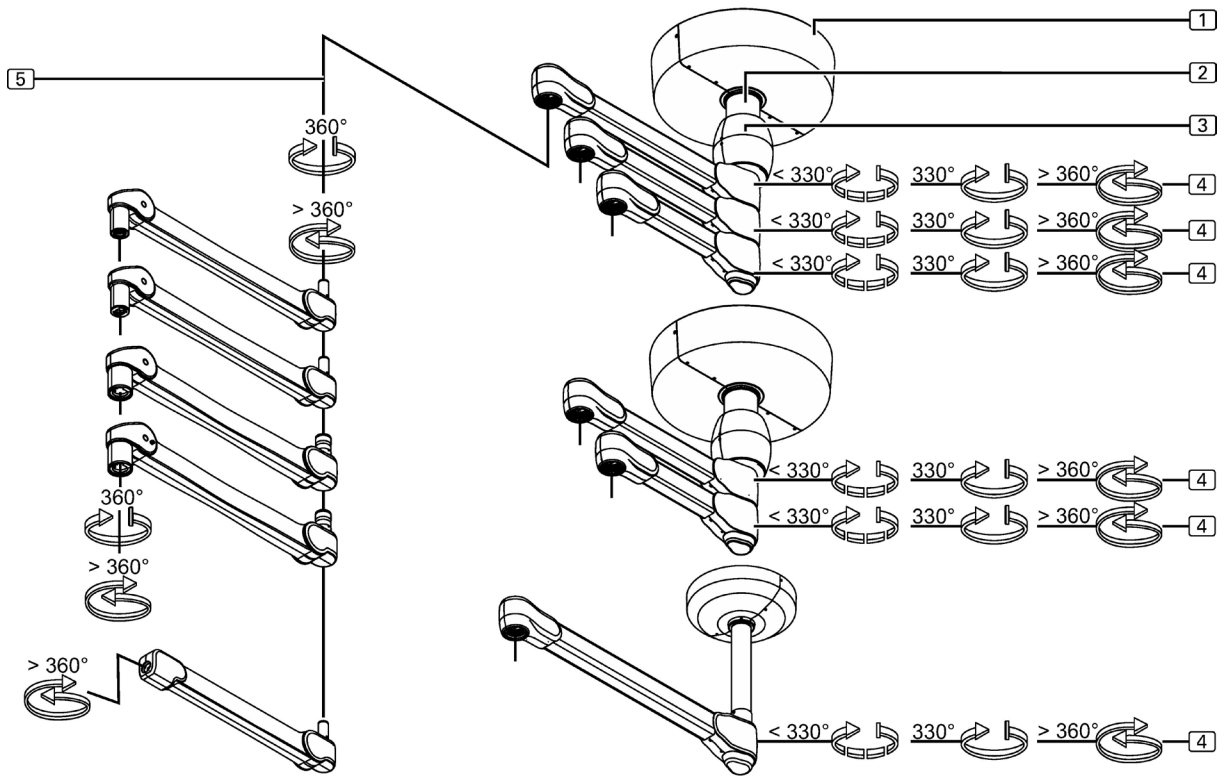

Height adjustment

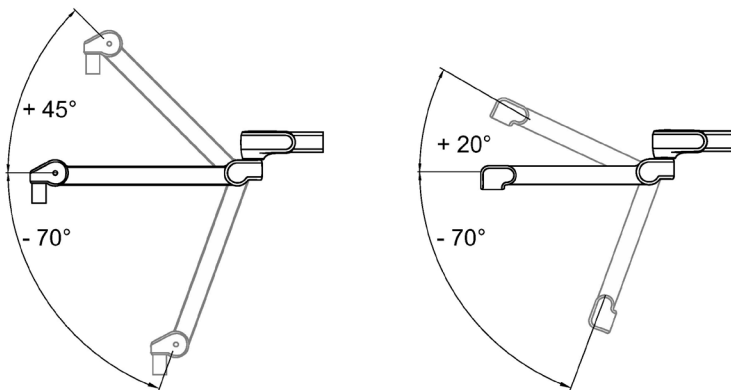

Brakes

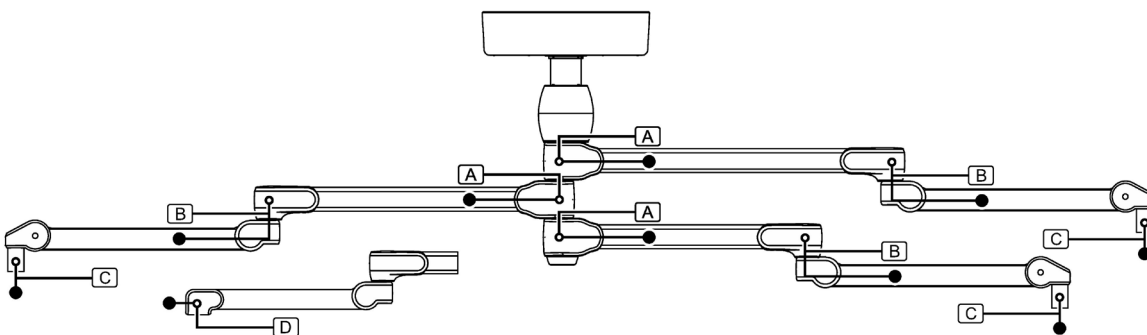

Parts and control elements

The schematic representation on page 3 illustrates the VistOR MS central axis S1, S2 and S3 versions as examples. The parts and control elements of the VistOR MS central axis C1 and C2 versions (not illustrated) are identical.

- [1] Ceiling Cover
There are two Covers available. The Standard Ceiling Cover is sufficient in most basic installations. The large Ceiling Cover should be used when needed to cover a larger area.
- [2] Ceiling tube
Variable lengths for compensating different ceiling heights
- [3] Rotating canopy
For VistOR MS LED central axis S2 and S3 versions only
- [4] Extension Arm
Different lengths depending on the version
- [5] Spring Arm
Different configurations (ie: Standard or Flat Cardanic for Light Head/Yoke assembly or & Monitor Cradle)

Thank you

Thank you for purchasing this Medical Illumination product. Please read these Operating Instructions very carefully, abide by the safety notices and observe all operating and cleaning requirements.

These Operating Instructions apply to;

VistOR MS LED Surgical Light and Central Axis S1

VistOR MS LED Surgical Light and Central Axis S2

VistOR MS LED Surgical Light and Central Axis S3

Please do not hesitate to contact our Customer Service team

if you have any questions about the appliance and its installation, and also in service or warranty cases.

Manufacturer and distributor

Medical Illumination International
19749 Dearborn Street,
Chatsworth, CA 91311
(818) 838-3025

www.medillum.com
cs@medillum.com

Visit us on the Internet
E-mail Address

Supplier's address



Space for supplier's stamp or label

Notes on these Operating Instructions

Copyright	<p>Notes on copyright and property rights</p> <ul style="list-style-type: none">• All rights reserved. These Operating Instructions are protected by copyright law.• Any other use than that regulated by law must be approved in writing by Medical Illumination International, hereinafter referred to as MI.• MI does not take any liability for or in relation to the misuse of this information in the prohibited manner by any person or company.
Modifications to the appliance	<p>Modifications and translations</p> <ul style="list-style-type: none">• MI products are subject to continuous further development. MI reserves the right to modify the form, equipment and technology of the scope of supply without prior notice.• The contents of these Operating Instructions are subject to change without prior notice.• In case of translations into foreign languages, the English version of these Operating Instructions shall take precedence
Modifications to the Operating Instructions	
Translations	<p>Trademarks</p> <ul style="list-style-type: none">• All trademarks mentioned in these Operating Instructions are the sole and exclusive property of the corresponding manufacturer.

Table of Contents

Section 1: General Information.....	9
Important Information for Safe Use.....	9
Definition of Terms	12
List of Symbols.....	13
Limited Warranty.....	14
Section 2: Product Specifications	15
Section 3: Pre-Installation Guidelines	17
Mounting Plate preparation with an Interface Plate.....	18
Ceiling Structure Construction and Mounting	19
Ceiling Cover.....	19
Power Box	20
Ceiling Rod Calculation, Single Mount	21
Ceiling Rod Calculation, Dual Mount	22
Ceiling Rod Calculation, Triple Mount	23
Ceiling Rod Calculation, Single LCH Mount	24
Ceiling Rod Calculation, Dual LCH Mount.....	25
Ceiling Rod Calculation, Triple LCH Mount.....	26
Section 4: Installing the Light System	27
Installing the Central Axis	27
Mounting the Extension Arm set to the Ceiling Tube.....	28
Mounting the Rotating Canopy.....	29
Mounting the L17 and LCH Spring Arm.....	30
Mounting the MD21/MD21+ Spring Arm.....	31
Preparing the MD21 Spring Arm.....	33
Preparing the L17 Spring Arm.....	35
Mounting the Light Head to L17 Spring Arm.....	36
Preparing the LCH Spring Arm	37
Mounting the Light Head to LCH Spring Arm	38
Mounting the LCH Spring Arm with Camera.....	39
Mounting the Light Head to the LCH Spring Arm with Camera	40
Positioning the Light.....	41
Section 5: Adjustments	42
Adjusting the Brakes for the Extension Arm	42
Adjusting the Brakes for the Spring Arm.....	45
Adjusting the Comfort Stop on the Extension Arm	47
L21/MD21 Spring Arm	49
Adjusting the Spring Tension	50
Adjusting the Vertical Lift.....	51
Adjusting the Optional Brake	52
Adjusting the Yoke Brake.....	55
Installation and Removal for the Sterilizable Handle Assembly (Camera Lights only).....	56
Installation and Removal for the HD Camera Assembly (Camera Lights only)	57
Section 6: General Maintenance.....	58
General Safety	58
Disinfection	59
Handle Sterilization and Cleaning	60
Maintenance.....	61
Mounting the securing segments.....	63
Checking the securing segment on the Spring Arm - L21/MD21	64
Dismantling and re-mounting the securing segment	65
Securing segment on the Spring Arm - LCH17	66
Dismantling and re-mounting the securing segment Spring Arm - LCH17	67
Checking the fixing screws on the Spring Arm - LCH17	68
Lubricating the brake screws	69
Installation & Service Checklist.....	70

Table of Illustrations

Figure 1: Ceiling Plate preparation with an Interface Plate	18
Figure 2: Recommended Ceiling Structure Construction	19
Figure 3: The Power Box.....	20
Figure 4: Installing the Central Axis on a 65mm Down Tube	27
Figure 5: Installing the Central Axis on a 110mm Down Tube.....	27
Figure 6: Mounting the Extension Arm set to the Ceiling Tube.....	28
Figure 7: Mounting the Rotating Canopy	29
Figure 8: Mounting the L17 and LCH Spring Arms.....	30
Figure 9: Mounting the MD21/MD21+	31
Figure 10: Mounting external cables.....	33
Figure 11: Preparing the L17 Spring Arm	35
Figure 12: Mounting the Light Head.....	36
Figure 13: Preparing the LCH Spring Arm	37
Figure 14: Mounting the Light Head to an LCH Arm	38
Figure 15: Preparing LCH Spring Arm with Camera - Screw Removal	39
Figure 16: Preparing LCH Spring Arm with Camera - Cover Removal.....	39
Figure 17: Mounting the LCH Spring Arm with Camera.....	39
Figure 18: Prepare the Light Head to Mount to the LCH Spring Arm with Camera	40
Figure 19: LCH Light Head with Camera Install.....	40
Figure 20: LCH Light Head with Camera - Install Securing Segment.....	40
Figure 21: Positioning the Arms	41
Figure 22: Dismantling the right-hand cover panels from the Extension Arm.....	42
Figure 23: Dismantling the left-hand cover panel from the Extension Arm	42
Figure 24: Adjusting the Extension Arm brakes	43
Figure 25: Mounting the right-hand cover panel to the Extension Arm.....	44
Figure 26: Mounting the left-hand cover panel to the Extension Arm	44
Figure 27: Dismantling the decorative caps and socket covers.....	45
Figure 28: Adjusting the brakes.....	45
Figure 29: Mounting the socket covers and decorative caps to the Extension Arms	46
Figure 30: Adjusting the Comfort Stop end stop on the Extension Arm	47
Figure 31: Spring Arm L21/MD21	49
Figure 32: Adjusting the spring tension	50
Figure 33: Adjusting the vertical lift	51
Figure 34: Adjusting the optional brake.....	52
Figure 35: Adjusting the vertical lift.....	53
Figure 36: Adjusting the optional brake.....	54
Figure 37: Yoke Rotational Brake - Double Yoke	55
Figure 38: Attaching the Sterilizable Handle	56
Figure 39: Camera Assembly (D2C only).....	57
Figure 40: Inserting Camera Assembly (D2C only).....	57
Figure 41: Handle Sterilization.....	60
Figure 42: Dismantling the decorative caps and socket covers from the Extension Arm	62
Figure 43: Dismantling the securing segment	62
Figure 44: Mounting the securing segment	63
Figure 45: Mounting the socket covers and decorative caps to the Extension Arm	63
Figure 46: Adjusting the L17/MD21 Spring Arm.....	64
Figure 47: Checking the securing segment	65
Figure 48: Adjusting the LCH17 Spring Arm.....	66
Figure 49: Checking the securing segment.....	67
Figure 50: Checking the fixing screws on the Spring Arm LCH17.....	68
Figure 51: Checking the securing ring on the bottom Extension Arm towards the spindle.....	68

Section 1: General Information Important Information for Safe Use

Important Information for Safe Use

- These Operating Instructions are intended solely for devices with the manufacturer's rating plate bearing the following information:
 - Type designation: S1, S2 and S3
- This identification is binding for the validity of the Operating Instructions and must not be removed, regardless of the type of publication (printed form, electronic form or excerpts).

Identification of target groups

The groups of persons described below are mentioned in these Operating Instructions.

Operator

The following natural persons or legal entities shall be considered as operators:

- All persons who use the appliance in a medical practice, hospital, etc. or hand over the appliance to third parties for use/application, and who have actual physical authority over the appliance during operation.
- The operator shall be liable for handing over a safe appliance and for instructing the user in the proper operation and normal use of the appliance.

User

The following persons shall be considered as users:

- Persons who, due to their professional qualification and instruction by the persons designated by the operator, are authorized to operate the appliance and to work with it.
- Users shall be fully responsible for the safe operation of the appliance in accordance with its intended purpose.

Qualified personnel

The following persons shall be considered as qualified personnel:

- Persons who underwent special professional training in the field of medicine or medical engineering,
- Persons who can assess their work and recognize the potential hazards involved on the basis of their professional experience and instruction in safety-relevant regulations.
- In States where the performance of tasks in the medical or medical engineering sector is subject to certification, qualified personnel must have obtained the corresponding certificate.

Important Information for Safe Use (cont)

Instruction	<p>Notes for the user</p> <ul style="list-style-type: none"> • All the steps described in these Operating Instructions may only be carried out by qualified personnel who have been authorized and instructed by the operator. <p>Instruction on the appliance</p> <ul style="list-style-type: none"> • The instruction must be carried out on the appliance immediately by Medical Illumination personnel, by a company authorized by Medical Illumination or by a person designated by the operator. • On completion of the instruction, a certificate must be created and signed in order to document that the user has understood the special operator control actions required for normal use.
Duty to inform and inspect	<p>User's duty to inform and inspect</p> <ul style="list-style-type: none"> • Read these Operating Instructions carefully prior to installation of the appliance. This ensures that you benefit from all the advantages of the appliance and prevents any risk of injury or damage. • Prior to any use or transfer for use, the functional reliability and proper condition of the appliance must be inspected by the user.
Troubleshooting	<ul style="list-style-type: none"> • In case of special problems which are not sufficiently described in detail in these Operating Instructions, contact your supplier for your own safety.

Qualified personnel

Important Information for Safe Use

- The system is suitable for continuous operation.
- The system may only be operated by instructed, qualified medical personnel.
- The system may only be cleaned and disinfected by instructed hygiene specialists.
- Maintenance work on the system must be carried out by the operator's technical specialist personnel in accordance with the applicable instruction document.

Incorrect use

- The maximum load bearing capacity of the system and its components as specified in Section 5, "Maximum Load" must not be exceeded.









Contraindications

- The system must not be used close to strong magnetic fields.

Definition of Terms

	I.E.C.	International Electrotechnical Commission
	ETL	Edison Testing Laboratories
	Medical Electrical Equipment	Electrical equipment intended to diagnose, treat the patient under medical supervision.
	Central Illuminance	Illuminance of light head measured at 1 meter from the light emitting area with no obstructions. The value is expressed in Foot-candles or Lux.
	Light Field Center	The point of maximum Illuminance in the lighted area. This is the reference point for light field size and light distribution measurements.
	Light Field Diameter	The diameter of the circle where Illuminance reaches 10% of light field center Illuminance.
	Depth of Illumination	The distance above and below 1 meter to where the central Illuminance is reduced to 20%.
	Shadow Dilution	The ability of the equipment to minimize the impact of shadows in the working area due to partial obstruction by the operator or other medical personnel.
	Correlated Color Temperature	The color temperature of the light fixture when compared to a blackbody radiator expressed in degrees Kelvin.
	Total Irradiance	The total amount of energy imparted to the patient by the lighting system expressed in Watts/meter squared.
	Color Rendering Index (CRI)	A method of how well a light source will render other colors when illuminating them based upon eight CIE chromaticity coordinates measured with a SpectroRadiometer.
	Sterilizable Handle	An easily removable device that when properly sterilized maintains a sterile area in order to handle it under aseptic conditions when attached to the equipment.
	Head/Yoke Assembly	The part of the system which includes the light source, heat removal system and light focusing system.
	Arm Assembly – Extension/Articulating Arm	The Horizontal section of the positioning arm with pivots that increase the area covered by the light head and articulating arm. The articulating arm allows for vertical positioning of the light head.
	Light Mounting	Support apparatus used to connect arm assembly/light head to a fixed surface, consisting of either a single, double or triple ceiling mount.
	Neutral Conductor (common)	In an AC circuit, the return line for current.
	Protective earth ground	The conductor used to connect the non-current-carrying metal parts of equipment, raceways, and other enclosures to the system grounded conductor, the grounding electrode conductor, or both, of the circuit at the service equipment or at the source of a separately derived system.
	Off Center Moment	The unit of measurement used for torque which is caused by an off-center load. This is measured in foot-pounds.

List of Symbols

	ETL Listing marking
	Read accompanying documents
	CE Marking
	Fuse marking
	Protective earth ground
	Neutral conductor
	Caution
	Electric shock hazard
	Separate collection for electric and electronic equipment. Do not dispose of as household waste.

Medical Illumination International, Inc. Limited Warranty

This document comprises the general terms of your product's Limited Warranty. This Limited Warranty is applicable to products sold by Medical Illumination International, Inc. or one of its subsidiaries or divisions (collectively, "MI") through one of MI's authorized dealers, distributors or sales representatives (an "Authorized Dealer"). This Limited Warranty is not applicable to any MI product not purchased from an Authorized Dealer. This Limited Warranty extends only to the first retail purchaser of a product and is not transferable or assignable.

Your product is warranted against defective material and/or workmanship, excluding normal replacement parts, for a period of three (3) years from the date of shipment. Normal replacement parts include, but are not limited to, bulbs, sterilizable handles, filters and glass items. This Limited Warranty applies exclusively to the repair or replacement of parts recognized as defective by MI that are in normal use and have not been modified or repaired by unauthorized personnel.

This Limited Warranty is in lieu of all other warranties, expressed or implied, including any implied warranty of fitness for a particular purpose and all other obligations or liabilities, including liability for incidental, special or consequential damages or labor.

In the event of a defect or failure covered under this Limited Warranty, please contact MI immediately by phone (818/838-3025), fax (818/838-3725), email (info@medillum.com) or through our website (<http://www.medillum.com>). Be prepared to give the model number, serial number and full description of the issue. This Limited Warranty will not apply if the MI serial number affixed to the product has been removed, obliterated or defaced.

Our Customer Service department will attempt to solve the problem over the phone. If it becomes necessary, we will determine, in our sole discretion, the best way to address the issue. We may require that the product be sent to our factory for repair. In limited instances, we may dispatch an authorized service technician. No product serviced by other than our authorized service technician will be covered by this Limited Warranty.

In the event we determine that your product needs to be repaired, either onsite or by return to our factory, please do not continue to use your product. MI is not responsible for any costs, expenses, losses or damage resulting from your continued use of the product prior to its authorized repair. MI is not responsible for costs or expenses incurred for loss of use of the product.

If we require the return of the product to our factory, you will be provided with a Return Authorization number. Products sent to the factory without a Return Authorization number will not be accepted. It is your obligation to arrange for return shipment of your product to the factory for warranty service, which shall be at your expense. Your Product must be returned to our factory within thirty (30) days of the date of the Return Authorization. Carefully package the product and return it, freight prepaid and insured, with the Return Authorization number clearly marked on the outside of the box, to Medical Illumination International, Inc., 19749 Dearborn Street, Chatsworth, CA 91311, RA# _____.

Damage resulting from inadequate packing is not covered by this warranty, and shipping insurance does not cover damage due to inadequate packing. MI cannot be held responsible for in-transit loss or damage. In the event that freight-related damage should occur, we will notify you immediately so that you can file a damage claim with the freight carrier.

Within the warranty period, MI will evaluate your returned product, repair as appropriate, and ship the product back to you with freight costs prepaid by MI. In the event that damage or failure is discovered that is not covered by this Limited Warranty, we will contact you for your approval of all costs that may be incurred prior to commencing any repairs.

This Limited Warranty does not cover the following:

- Any field labor or outside services, including, but not limited to, electricians, contractors, installation services, routine maintenance or other repair services.
- Damage to the product resulting from tampering, accident, abuse, negligence, alteration or other causes unrelated to problems with material and/or workmanship.

- Damage due to improper installation, use, cleaning or maintenance, as outlined in the Installation and Service Manual.
- Labor costs associated with removing, re-packaging for shipment or reinstalling product

Limited Warranty, Rev 8-23

Section 2

Section 2: Product Specifications

Mechanical Specifications

Parameter	Value
Weights:	
Ceiling Mounting Plate	Approximately 7.2 lbs (3.3kg) to 58.2 lbs (26.5kg)
Single Central Axis	Approximately 20.9 lbs (9.5kg)
Dual Central Axis	Approximately 38.3 lbs (17.4kg)
Triple Central Axis	Approximately 54.3 lbs (24.7kg)
Spring Arm – L21	Approximately 16.1 lbs (7.3kg)
Spring Arm – LCH	Approximately 14.3 lbs (6.5kg)
Spring Arm – MD21 (Monitor Spring Arm)	Approximately 16.5 lbs (7.5kg)
Light Head assembly	Approximately 28.1 lbs (12.8kg)
Power Box (Dual Light)	Approximately 8.8 lbs (4.0kg)
Dimensions:	
Ceiling Mount Plate	11.2" (290mm) Hex Mounting Plate
Available Ceiling Rod lengths	8" (200mm) 16" (400mm) 24" (600mm) 32" (800mm) 39" (1.0m) 47" (1.2m)
Central Axis Extension Arm lengths - Single	41.3" (1,050mm)
Central Axis Extension Arm lengths - Dual	41.3" (1,050mm) / 35.4" (900mm)
Central Axis Extension Arm lengths - Triple	41.3" (1,050mm) / 35.4" (900mm) / 29.5" (750mm)
Spring Arm length	36.2" (920mm)
Light head assembly	25.5" (648 mm) Dia. x 4.75" (120 mm) deep

Electrical Specifications

Voltage Input Voltage	100 - 240 VAC 50/60 Hz – Single Phase
LED life	50,000 hours (average)
Power:	
Single	180 Watts
Dual	360 Watts
Triple	540 Watts

Section 2: Specifications

Optical Specifications

Correlated Color Temperature	
D-Series	Fixed at 4,300°K ±300°K
Vu-160	Fixed at 4,300°K ±300°K
Vu-E	Variable between 3,800°K to 4,800 °K ±300°K
Irradiance	128 W/m ² (1 m)
Color Rendering Index (CRI R1-R8=RA)	95
Color Rendering Index R9	95
Focal length	39.4" (1 meter)
D-Series Central Illuminance (full intensity)	130,000 ± 5K Lux.
Dimming – 5 Intensity Levels	100% 87.5% 75% 62.5% 50%
(Indicated by 5 LED's on 2 indicator strips located 180° apart)	130,000 113,750 97,500 81,250 65,000
Vu-160/Vu-E Central Illuminance (full intensity)	160,000 +0 / -10K LUX @4,300°K
Dimming – 5 Levels	100% 87.5% 75% 62.5% 50%
(Indicated by 5 LED's on 2 indicator strips located 180° apart)	160,000 140,000 120,000 100,000 80,000
	LUX LUX LUX LUX LUX
Endo Mode	
D-Series	10% - 12 white LED's triangulated 120° apart (8,500 LUX)
Vu	7.4% - 6 green LED's located 60° apart @4300°K
Light field diameter (adjustable)	9.5" – 14" (229mm – 356mm)
Depth of illumination	32.3" (820mm)
Diameter (d50)	5.5" (127mm – 140mm)
Illuminance (one mask)	74,560 Lux (6,930 fc)
Illuminance (two masks)	62,408 Lux (5,800 fc)
Illuminance at bottom of standard tube	132,300 Lux (12,300 fc)
Illuminance at bottom of standard tube with one mask	72,630 Lux (6,750 fc)
Illuminance at bottom of standard tube with two masks	60,256 Lux (5,600 fc)

Environmental Specifications

Ambient/Operating temperature	41°F to 104°F (-10°C to 40°C)
Storage temperature range	-4°F to 122°F (-20°C to 50°C)
Humidity	10% - 75% Relative Humidity
Pressure	500 hPA to 1,060hPA (@<2K meters)

Section 3: Pre-Installation Guidelines

SPECIAL NOTE: Installation and repair of this equipment should be performed by a qualified mechanical contractor only. Medical Illumination does not warranty any damage occurring as a result of improper installation.

It is recommended that this installation manual be completely reviewed prior to installation.

Before installation, check to ensure the following minimum conditions are provided:

- The structural ceiling mount is designed to support a vertical load of 300 lbs (triple) and an off-center moment of 960 ft-lbs, the single light is significantly less. The structural mount should meet all local building codes.



A structural mount that does not meet these minimum conditions can cause serious injury and/or property damage.



Failure to use the correct mounting hardware can cause the arm/head assembly to become unstable, causing serious injury and/or property damage. If the ceiling mounting surface is not level, shim the ceiling casting to level the assembly.



Failure to level the ceiling plate may cause unwanted arm “drifting” during use.

- It is recommended that the Power Box be mounted directly over a 4-0 junction box. If this is not possible the input power supply lines should be wired in accordance with all applicable building codes.
- The supply circuit line must be as follows:
120 VAC lights- 110-120 VAC 50/60 Hz, single phase, three wire, capable of supplying 700 watts @ 6.4 amperes.
230 VAC lights- 220-240 VAC, 50/60 Hz, single phase, three wire, capable of supplying 700 watts @ 3.2 amperes.
- The power supply circuit must be in compliance with all applicable building codes.
- It is recommended that the Lighting System is connected to its own supply circuit with integral circuit breaker. The circuit breaker will act as the supply main disconnect switch.
- The MAINS ground wire, which is green and has a ring-type terminal at the end, should be securely fastened to the mounting plate with a screw and lock washer.



Failure to provide a circuit meeting these minimum standards or complying with local building codes can cause a shock hazard.

- Check the length of the ceiling rod supplied to make sure that it is the proper length to install and operate the light without interference or over reach. See the Ceiling Rod Calculations.

Mounting Plate preparation with an Interface Plate

If you choose to an Interface Plate in mounting your Light System, you should only use 5/8-11, A325 High Strength Threaded Rods, Hex Nuts and Washers. The following will illustrate the recommended hardware complement.

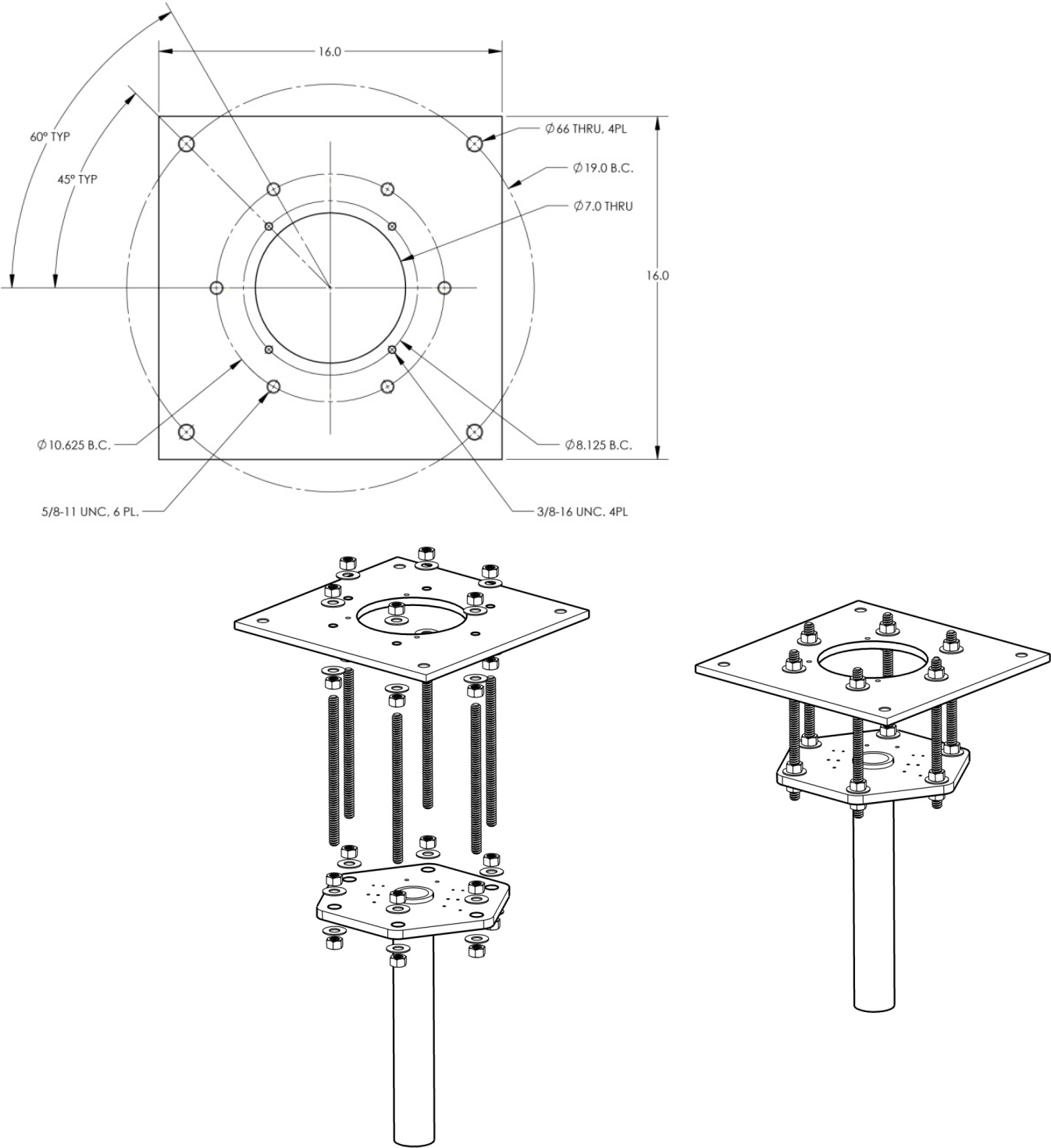

Figure 1: Ceiling Plate preparation with an Interface Plate

Ceiling Structure Construction and Mounting

The Ceiling Mount system will experience various levels of dynamic off center moment during regular use. Therefore, it is crucial that the ceiling structure be strong enough to uphold the weight of the system and support the positioning arms and light head without deflection. The owner and/or owner's contractor has the final responsibility for the strength and rigidity of the ceiling structure. An inadequate ceiling structure may result in serious injury, unintended drift, and/or equipment damage. **Because the ceiling structure is the owner's responsibility, the design and construction recommendation shown below covers only one of the many possible alternatives that can be used.** Medical Illumination highly recommends that the owner consult a structural engineer prior to designing and installing the ceiling structure.

Recommended Ceiling Structure Construction Details

The illustrations below are suggested mounting schemes per 2001 California Building Code – Section 1632A: Anchorage and Seismic. For any other mounting scheme, please consult a structural engineer and/or professional contractor for the best solution for your situation. Installation and repair of this equipment should be performed by qualified persons only. Medical Illumination does not warranty any damage occurring as a result of improper installation.

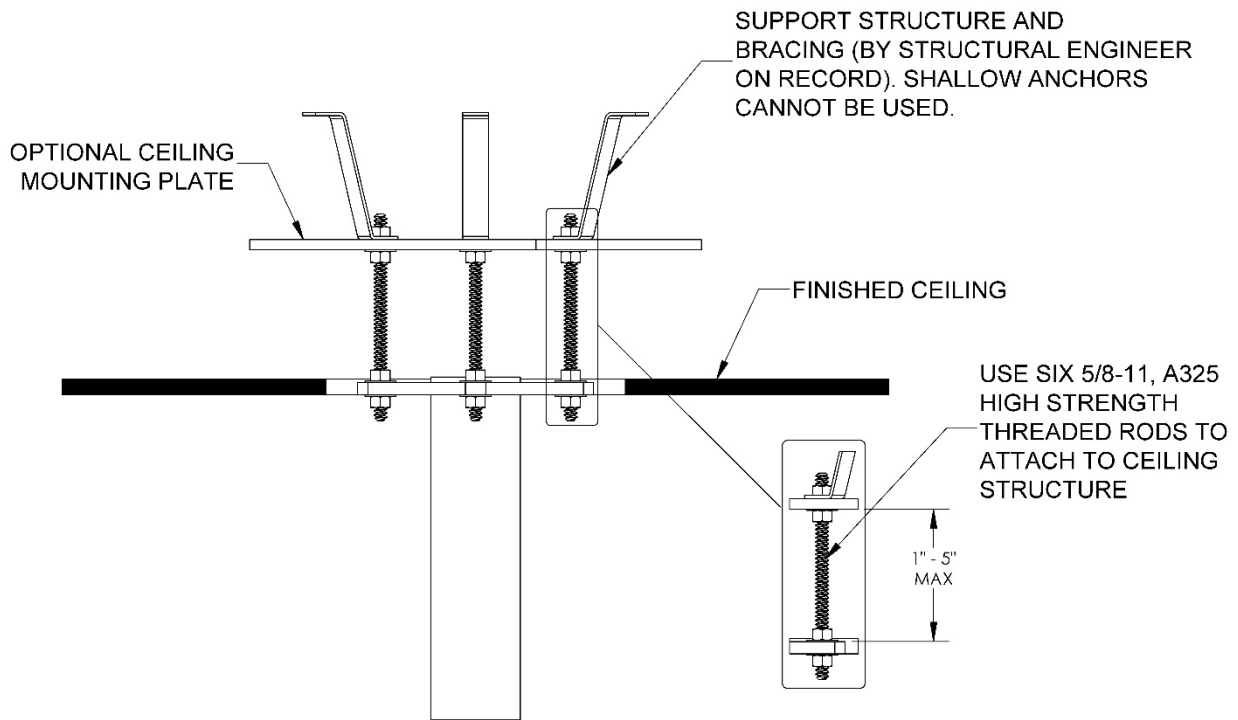
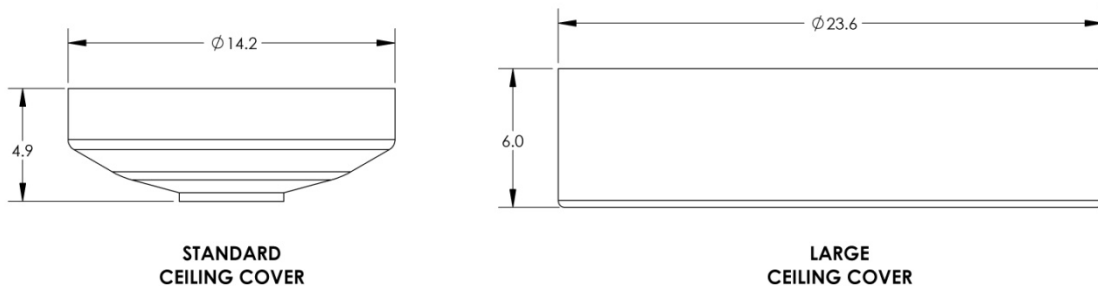

Figure 2: Recommended Ceiling Structure Construction

Ceiling Cover

The Standard Ceiling Cover is included with the system and can be used in most installations. If the finished ceiling level is above the mounting plate, or there is a larger ceiling opening, a larger Ceiling Cover is available.



Power Box

The VistOR MS LED Power Box supplies the power necessary to illuminate the VistOR MS LED surgical light systems. Remove the four screws on the top cover and lift cover off to make connections or change a fuse.

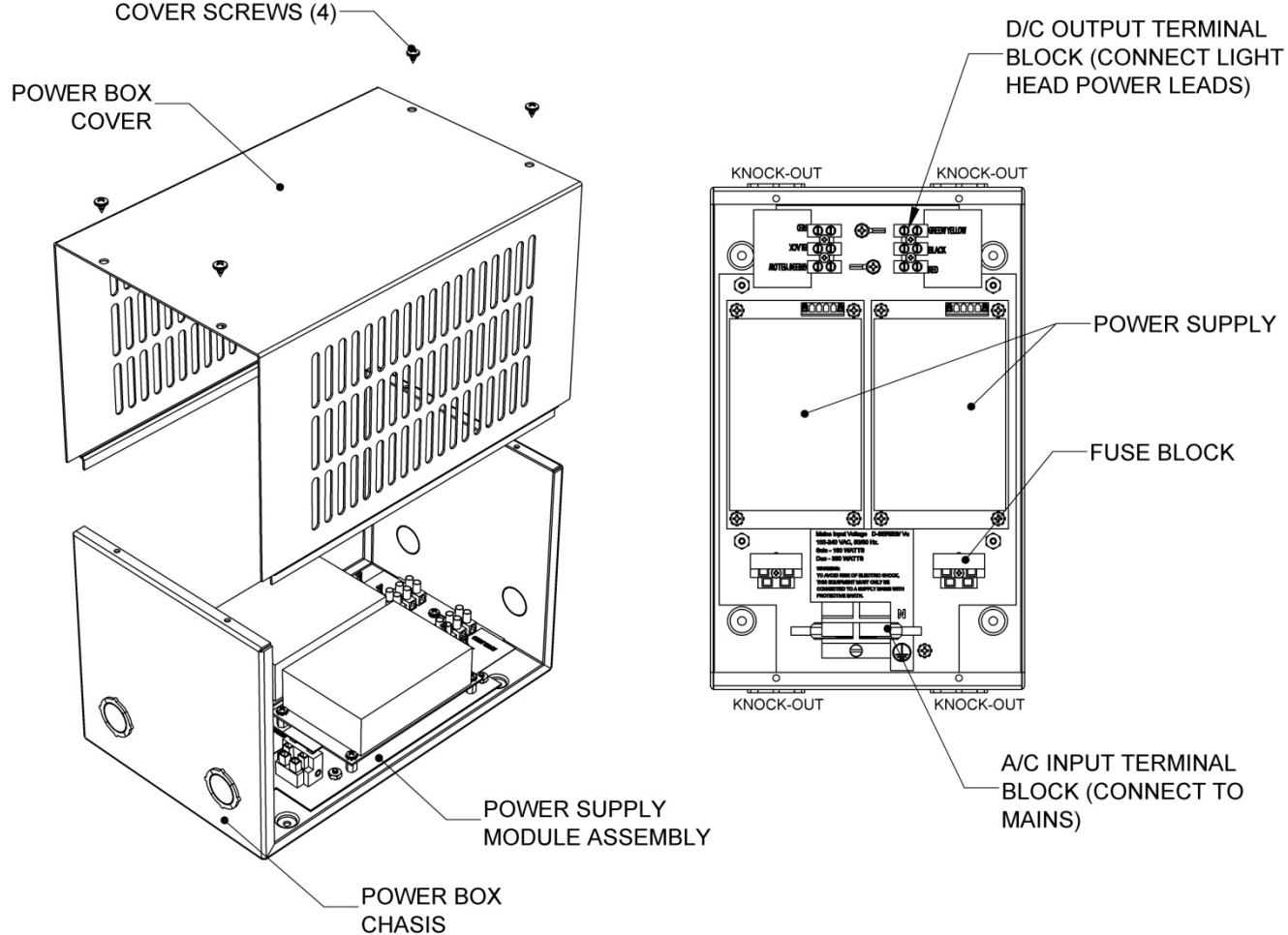

NOTE: INTERNAL WIRING NOT SHOWN FOR CLARITY

DUAL POWER SUPPLY SHOWN

Figure 3: The Power Box

Ceiling Rod Calculation, Single Mount

Use the following table to select the correct length ceiling rod for your application

Ceiling Mounting Height "Y"-Value	Ceiling Rod Length	"X"-Value	Head Room to Bottom of Extension Arm "Y"-Value – X-Value
9'0"/108"	8"	19"	89"
9'6"/114"	16"	27"	87"
10'0"/120"	24"	35"	85"
10'6"/126"	32"	43"	83"
11'0"/132"	39"	50"	82"
12'0"/144"	47"	58"	86"

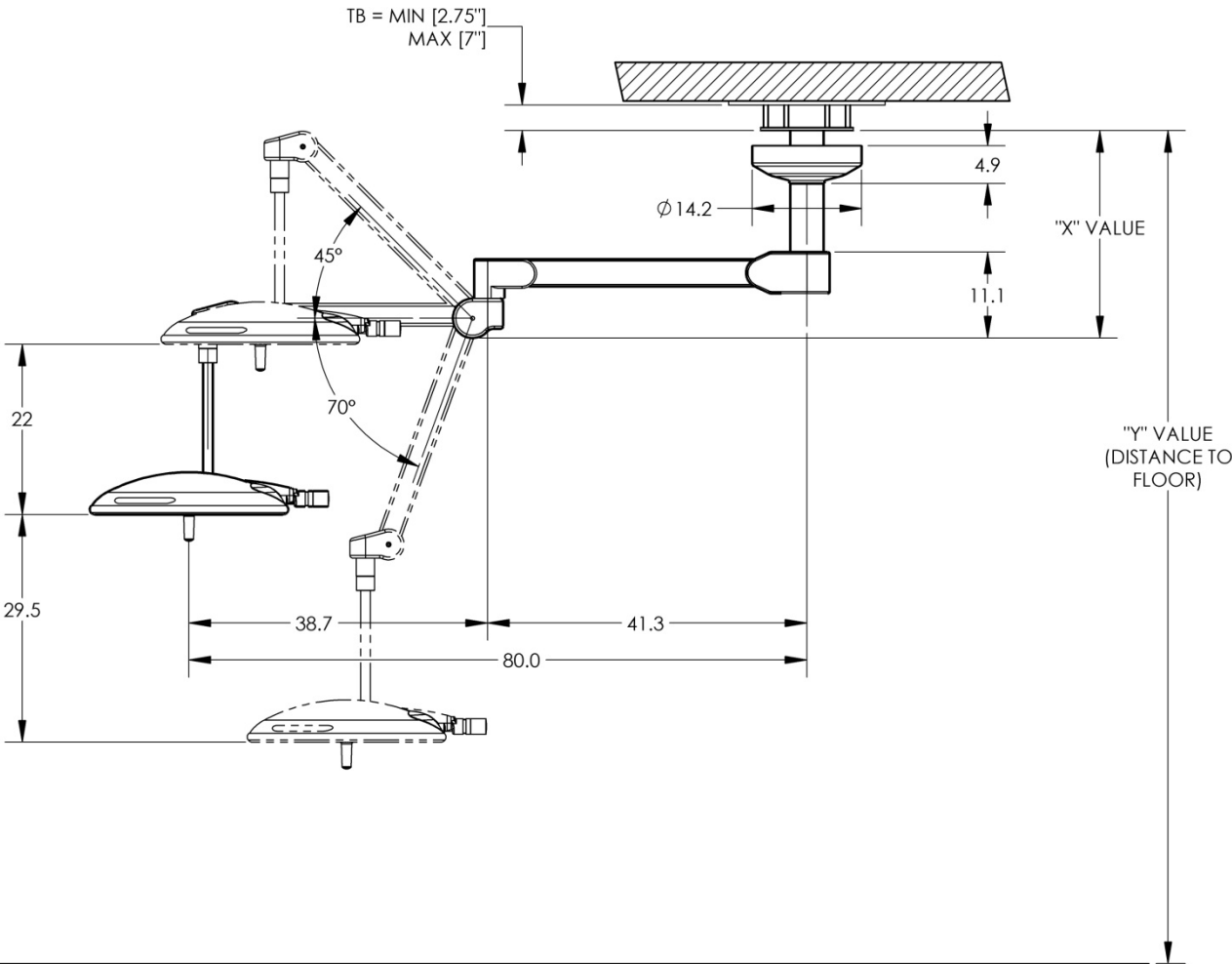

Ceiling Rod Calculation, Dual Mount

Use the following table to select the correct length ceiling rod for your application

Ceiling Mounting Height "Y"-Value	Ceiling Rod Length	"X"-Value	Head Room to Bottom of Extension Arm "Y"-Value – X-Value
9'0"/108"	N/A	N/A	N/A
9'6"/114"	16"	32"	82"
10'0"/120"	16"	32"	88"
10'6"/126"	24"	40"	86"
11'0"/132"	32"	48"	84"
12'0"/144"	39"	56"	88"
12'0"/144"	47"	64"	80"

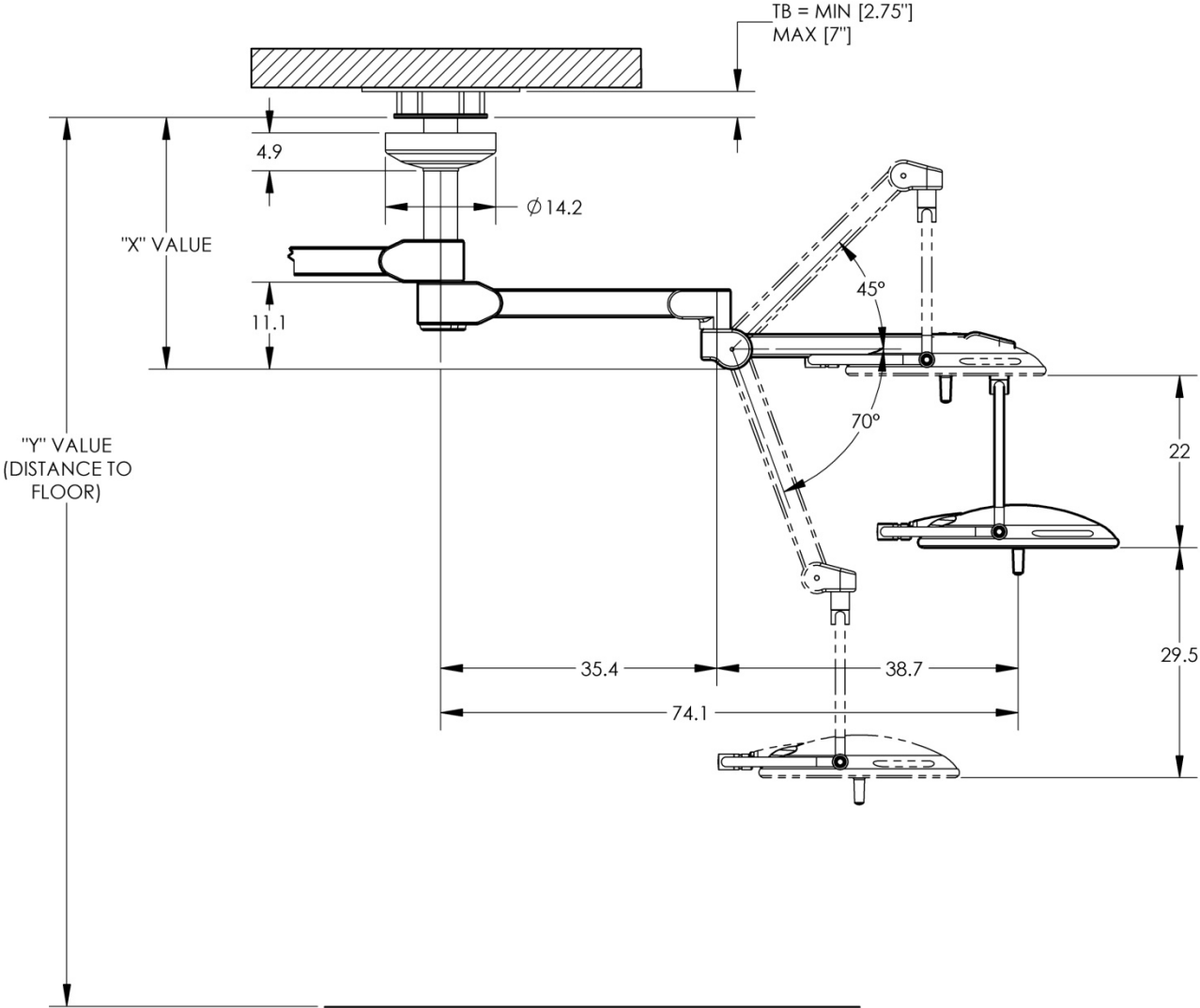

Ceiling Rod Calculation, Triple Mount

Use the following table to select the correct length ceiling rod for your application

Ceiling Mounting Height "Y"-Value	Ceiling Rod Length	"X"-Value	Head Room to Bottom of Extension Arm "Y"-Value – X-Value
9'0"/108"	N/A	N/A	N/A
9'6"/114"	N/A	N/A	N/A
10'0"/120"	16"	41"	79"
10'6"/126"	24"	49"	77"
11'0"/132"	24"	49"	83"
12'0"/144"	32"	69"	75"

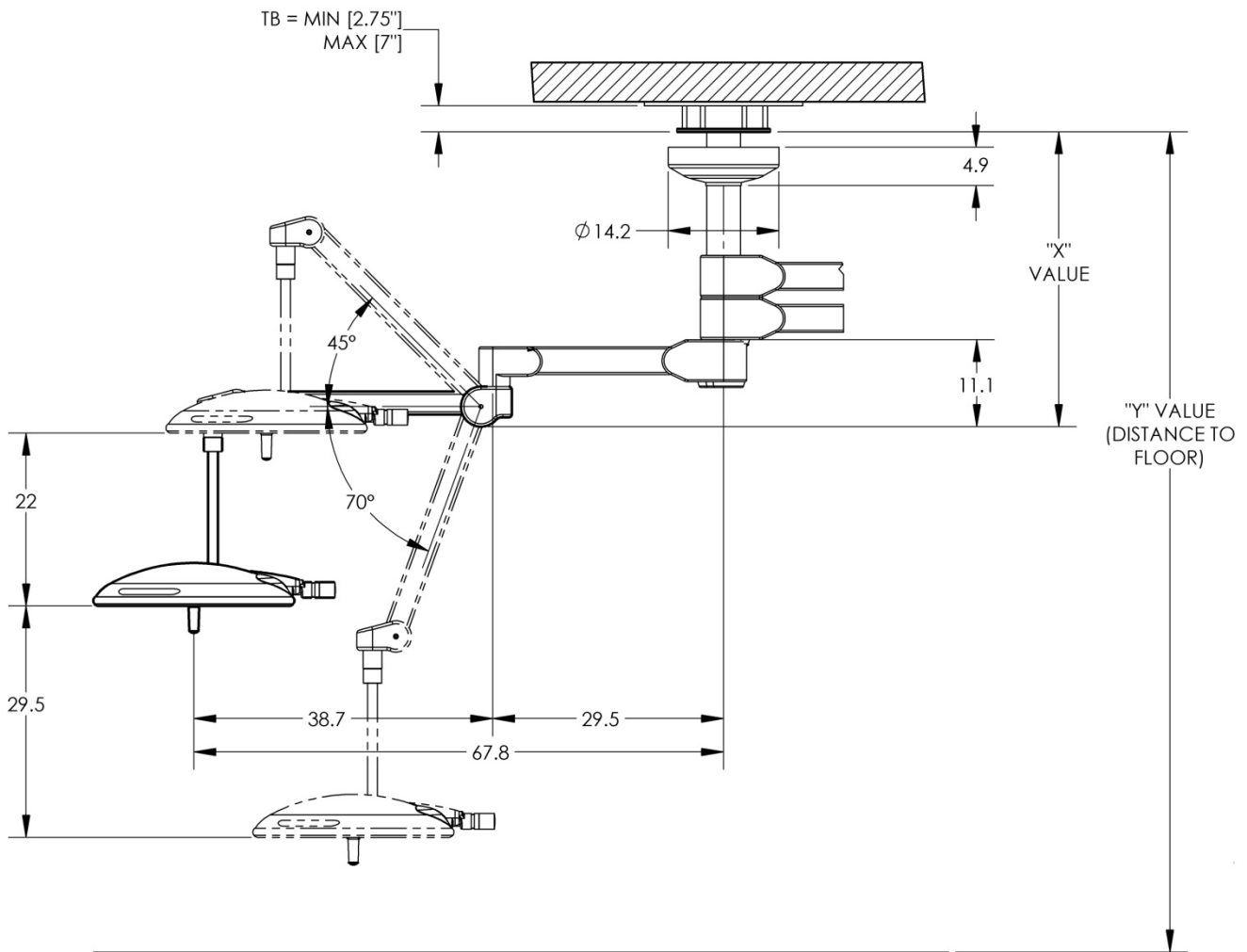

Ceiling Rod Calculation, Single LCH Mount

Use the following table to select the correct length ceiling rod for your application

Ceiling Mounting Height "Y"-Value	Ceiling Rod Length	"X"-Value	Head Room to Bottom of Extension Arm "Y"-Value - X-Value
9'0"/108"	8"	19"	89"
9'6"/114"	16"	27"	87"
10'0"/120"	24"	35"	85"
10'6"/126"	32"	43"	83"

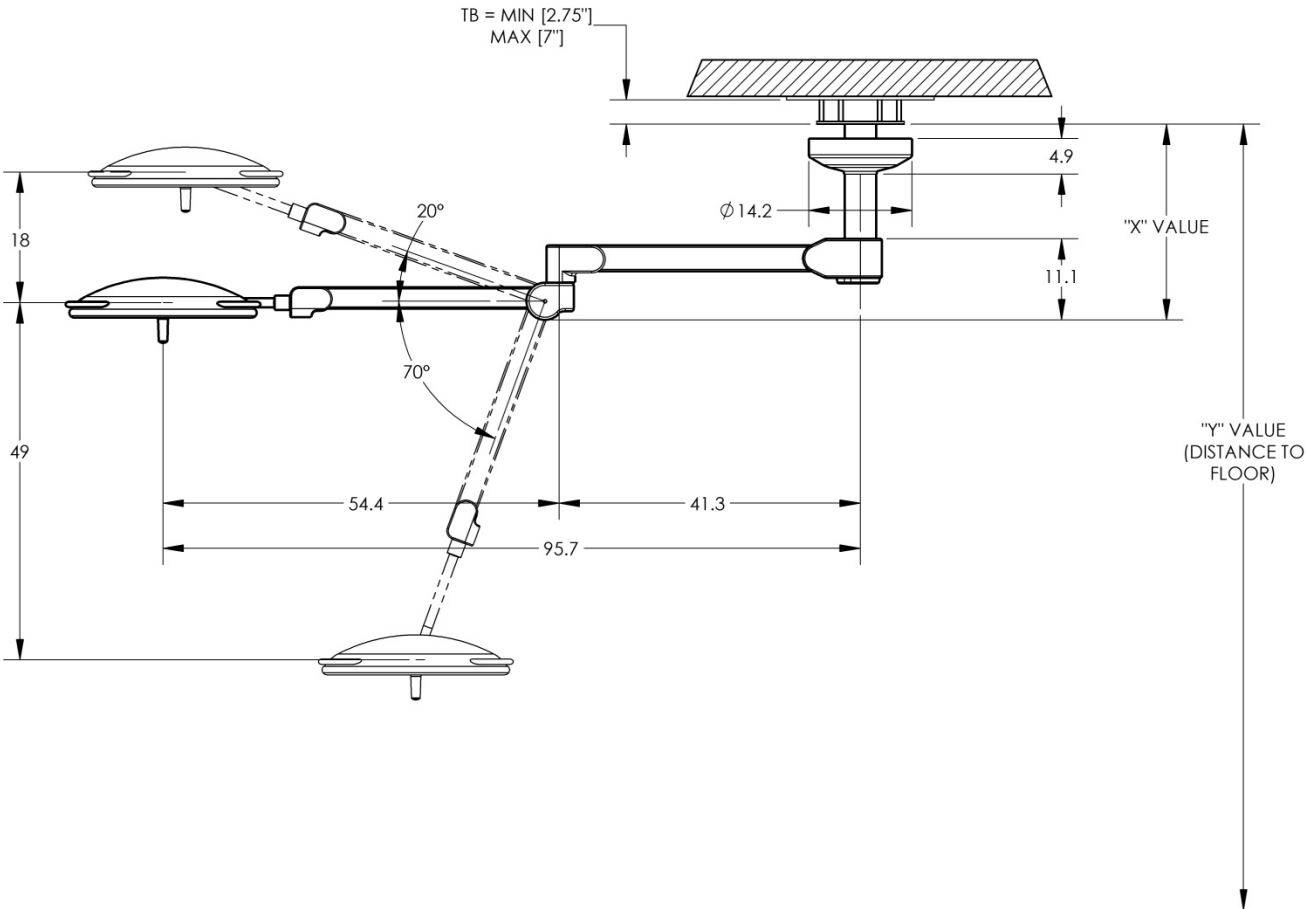

Ceiling Rod Calculation, Dual LCH Mount

Use the following table to select the correct length ceiling rod for your application

Ceiling Mounting Height "Y"-Value	Ceiling Rod Length	"X"-Value	Head Room to Bottom of Extension Arm "Y"-Value - X-Value
9'0"/108"	8"	24"	84"
9'6"/114"	16"	32"	82"
10'0"/120"	24"	40"	80"
10'6"/126"	32"	48"	78"

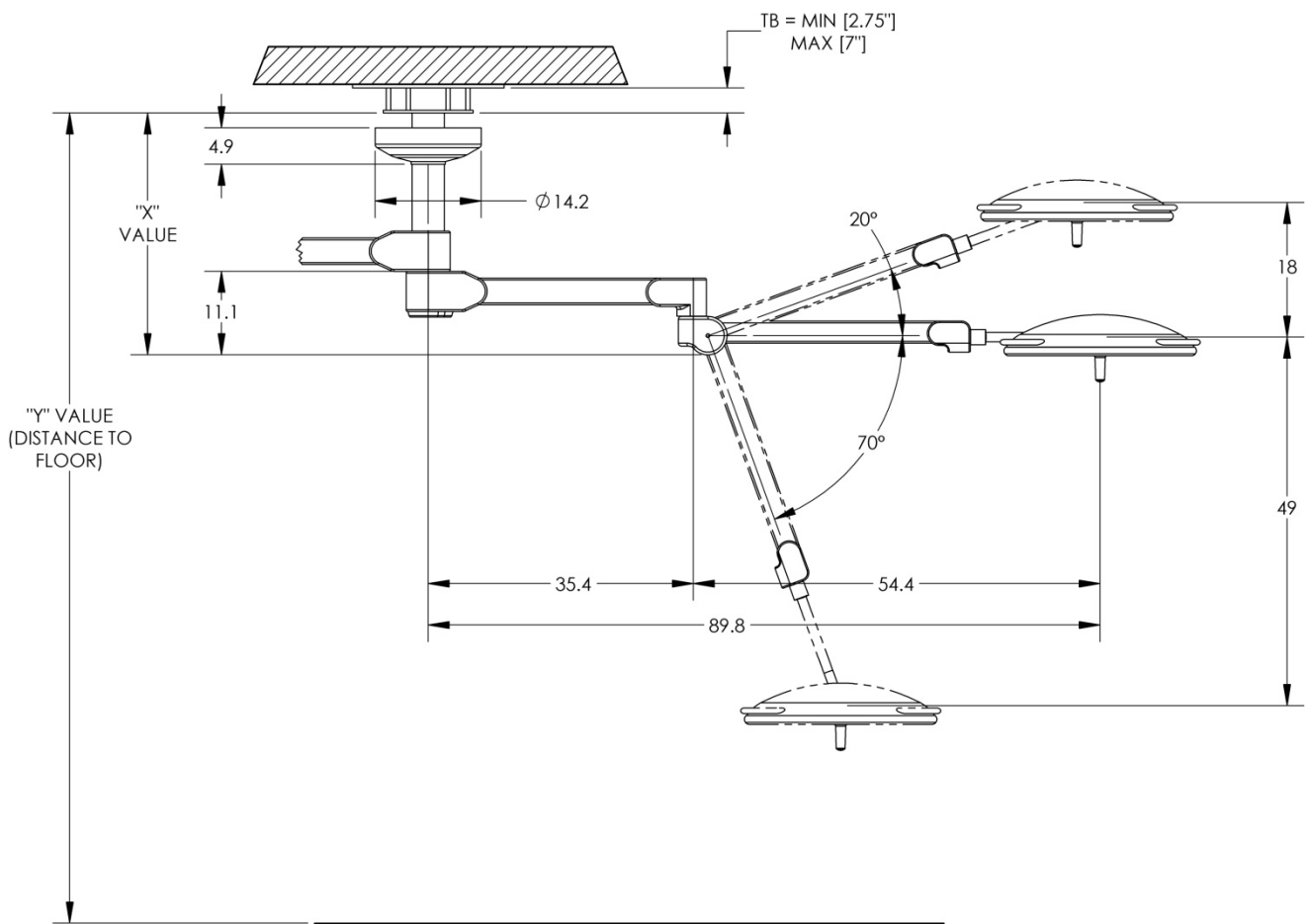

Ceiling Rod Calculation, Triple LCH Mount

Use the following table to select the correct length ceiling rod for your application

Ceiling Mounting Height "Y"-Value	Ceiling Rod Length	"X"-Value	Head Room to Bottom of Extension Arm "Y"-Value - X-Value
9'6"/114"	16"	41"	73"
10'0"/120"	16"	38"	82"
10'6"/126"	24"	45"	81"

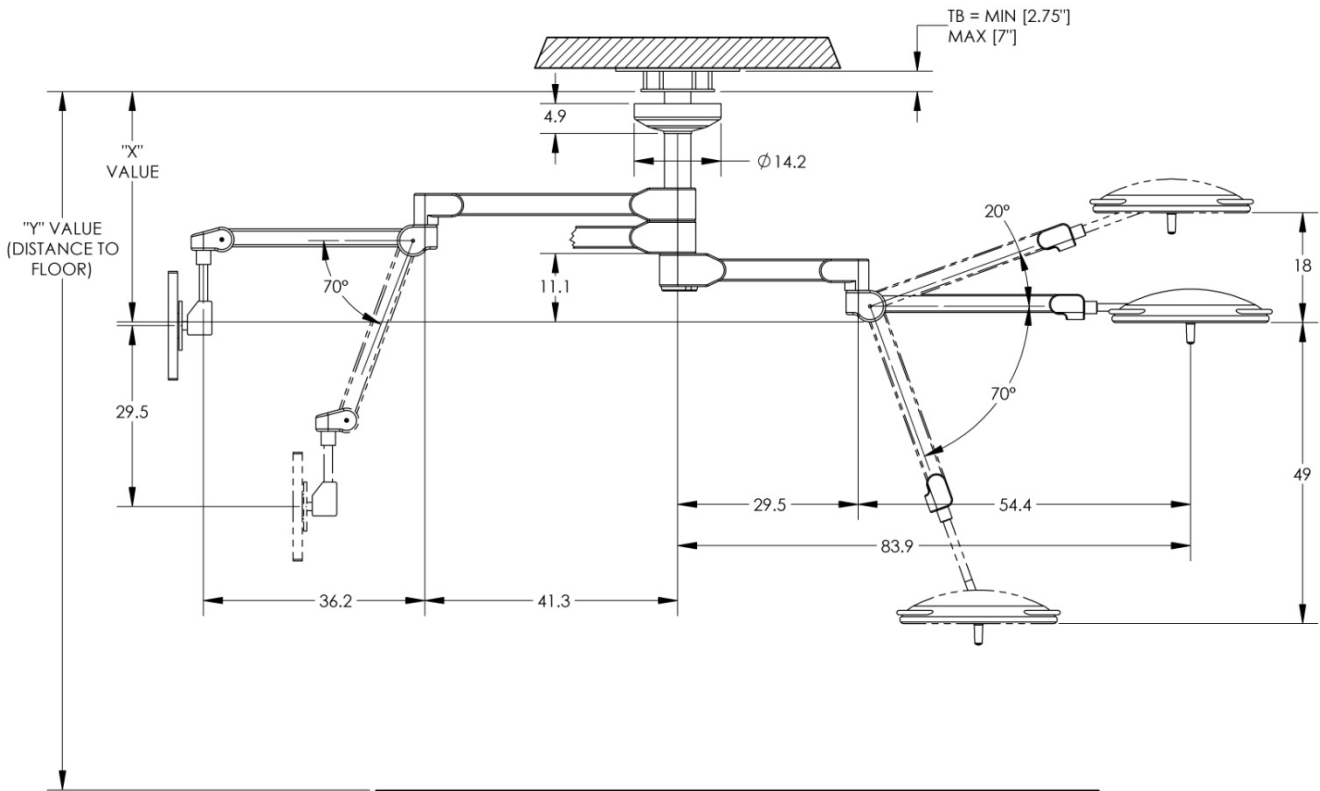

Section 4: Installing the Light System

Installing the Central Axis

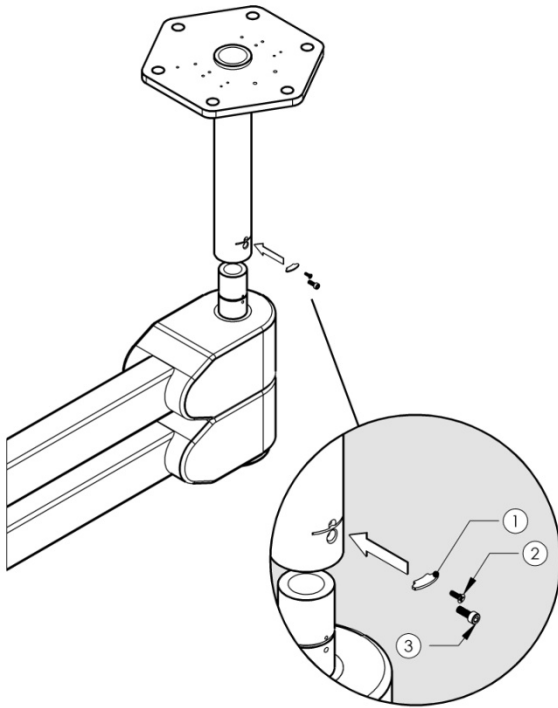

Figure 4: Installing the Central Axis on a 65mm Down Tube

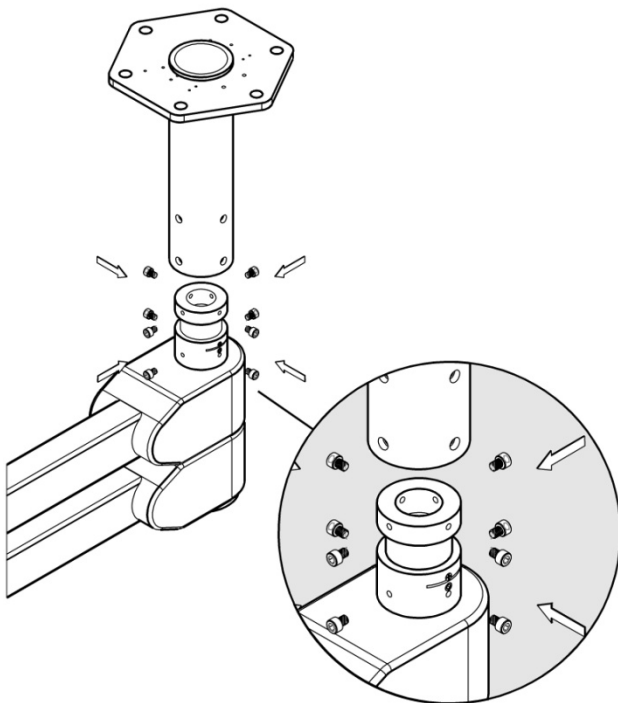

Figure 5: Installing the Central Axis on a 110mm Down Tube

Installing the Central Axis requires two people and using an equipment lift is HIGHLY recommended. See Section 3 for the Mounting Plate and Ceiling Structure guidelines.

Once the support structure and Hex Plate/Down Tube are securely installed and level, the Central Axis is ready to be installed. Locate the Securing Segment, Flat Head Screw and Allen Cap Screw and have ready.

NOTE: The DC Power Cables and Ground Cable (not shown) coming out of the Central Axis must be guided up through the Down Tube while lifting the hub of the Central Axis up into the Down Tube.

Using an equipment lift position the Central Axis under the bottom of the Down Tube. Carefully position the Central Axis so that the hub aligns with the Down Tube.

Lift the Central Axis until the hub goes up into the Down Tube until it lines up with the Securing Segment slot. Insert a greased Securing Segment until it stops and ensure that it is seated. The outer edge of the Securing Segment must be inside the outer diameter of the Down Tube.

With the Securing Segment installed, insert the Flat Head Screw into the top hole and then install the Allen Cap into the lower hole. Slowly remove height from the equipment lift and check the rotations. If the Central Axis rotates smoothly and without binding, tighten the Allen Cap and then tighten the Flat Head Screw. Recheck the ease of rotation.

The tightness of the Flat Head Screw and the Allen Cap should be incorporated into the equipment Preventative Maintenance Program

Mounting with the 110mm Down Tube

Using an equipment lift position the Central Axis under the bottom of the Down Tube. Carefully position the Central Axis so that the hub aligns with the Down Tube.

Lift the Central Axis until the hub goes up into the Down Tube. Continue lifting until the screw holes in the Down Tube aligns with the thread holes. Insert the 8 socket cap screws ensuring that the screws are seated and sufficiently tight.

Rotate the Extension Arm(s) to ensure free and smooth rotation.

The tightness of the Flat Head Screw and the Allen Cap should be incorporated into the equipment Preventative Maintenance Program

Mounting the Extension Arm set to the Ceiling Tube

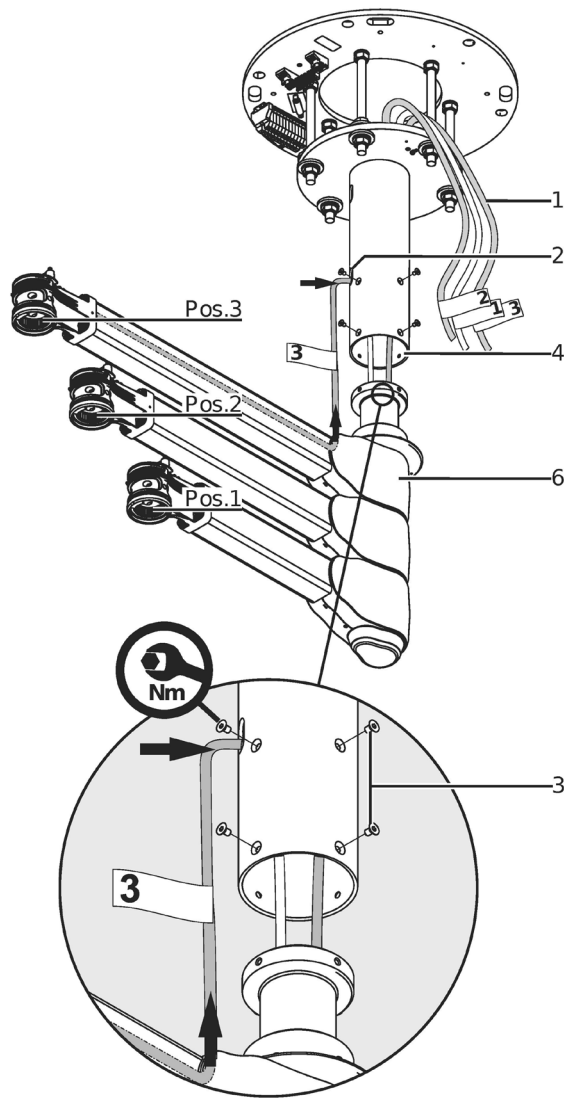

Figure 6: Mounting the Extension Arm set to the Ceiling Tube

The figure shows an illustration of a Central Axis with 3 Extension Arms (6). The installation procedure for other versions is identical.

1. Route the supply cable (1) through the flange with the Ceiling Tube (4) towards the mounting plate.
2. Insert the supply cable for the upper Extension Arm into the mounting aperture (2) in the flange with the Ceiling Tube (4) and route it towards the mounting plate.
 - Provide a cable length of approx. 80cm for the cable loop to be laid afterwards in the rotating canopy.
3. Remove the packaging from the Extension Arm set [6] pivot.
 - Make sure you do not remove the lubricant from the Extension Arm set (6) pivot.
4. Before inserting the Extension Arm set [6] into the ceiling tube, rotate it in position such that the holes for the 8 countersunk screws (3) in the ceiling tube and Extension Arm align.
5. Insert the Extension Arm set (6) into the flange with ceiling tube (4) without using a great deal of force and without twisting.
 - To do this, make sure you route the supply cables (1).

***** Warning *****

The Extension Arm can drop of the fixing element have not been properly tightened.

6. Screw in 8 countersink screws and tighten to 10Nm.
7. Check the horizontal alignment of the Extension Arm set (6).
 - Place the digital level onto the uppermost Extension Arm set (6).
 - Rotate the Extension Arm (6) 90° in various directions and check the horizontal alignment.
 - The deviation from the horizontal must not exceed $\pm 0.2^\circ$.
 - In case of deviations by more than 0.2° the Extension Arm (6) must be realigned as described in step 7 above.

Mounting the Rotating Canopy

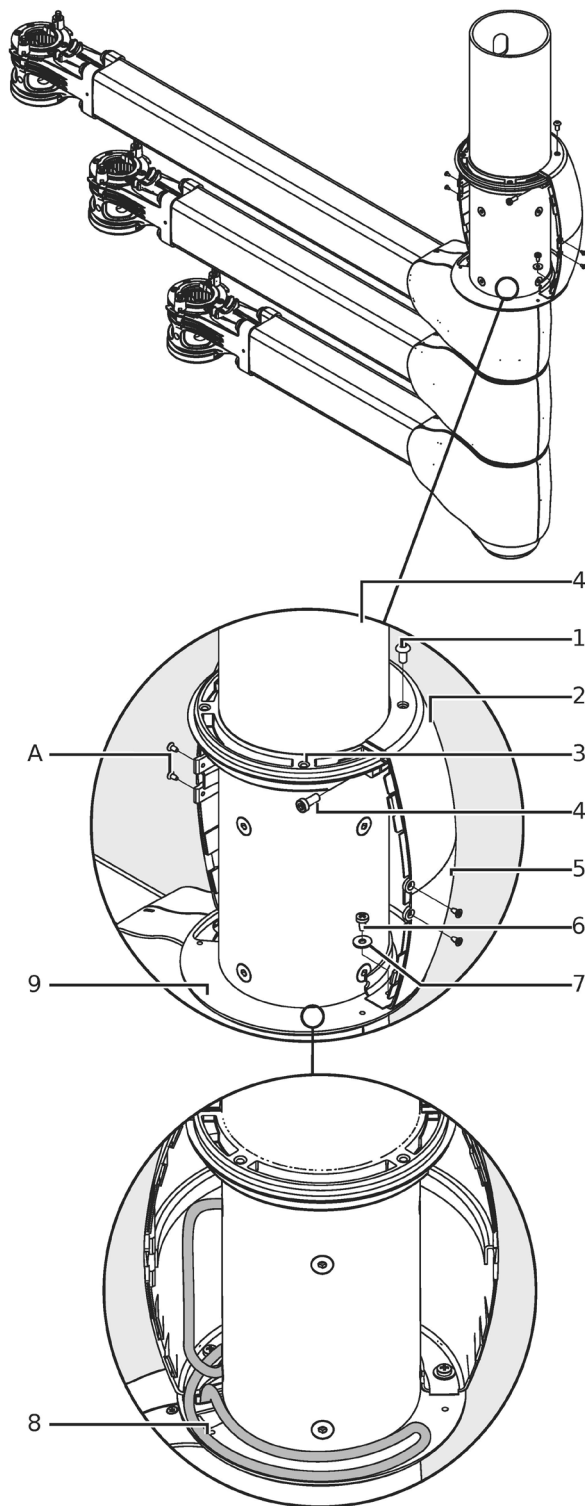

Figure 7: Mounting the Rotating Canopy

The figure shows a simplified representation of the ceiling tube without flange.

1. Lay 2 half rings for the rotating canopy (3) around the flange with ceiling tube [4] (with the threaded holes pointing inwards); screw in the 2 cylinder screws (4) and tighten them such that the 2 rotating canopy half rings (3) can still move manually.
2. Place 1 disc Ø4.3 (7) on each fillister head screw (6).
3. Place the first bottom rotating canopy half (5) onto the rotating canopy disc (8) and screw it on using 2 fillister head screws (6) and the disc Ø4.3 (7).
4. Push the rotating canopy half rings (3) towards their correct position and then insert the first, top rotating canopy half (2) into the bottom rotating canopy half (5).
 - Make sure you leave a gap of approximately 0.04" (1mm) between the top and the bottom rotating canopy half (5).
5. Screw the first, top rotating canopy half (2) into the rotating canopy half rings (3) using 2 fillister head screws (1).
6. Lay the supply cable (8) in the rotating canopy halves in a loop as illustrated in the Figure such that the supply cable (8) is not exposed to tensile stress when rotating the upper Extension Arm.
 - Make sure that the supply cable (8) is not exposed to tensile stress in the 2 end stop positions.
7. Please the second, bottom rotating canopy half (not illustrated) onto the rotating canopy disc (9) and screw it on using 2 fillister head screws.
8. Screw the second, top canopy half (not illustrated) onto the rotating canopy disc (9) and screw it on using 2 fillister head screws (1).
9. Connect the 4 rotating canopy halves with each other using 4 PT screws (10).
10. Check that the canopy halves are securely in place.
 - The rotating canopy halves must engage tightly with each other without gaps.
 - The locking mechanisms on the rotating canopy halves must be undamaged and lock against each other.
 - Make sure that all the screws are tightened.

Mounting the L17 and LCH Spring Arm

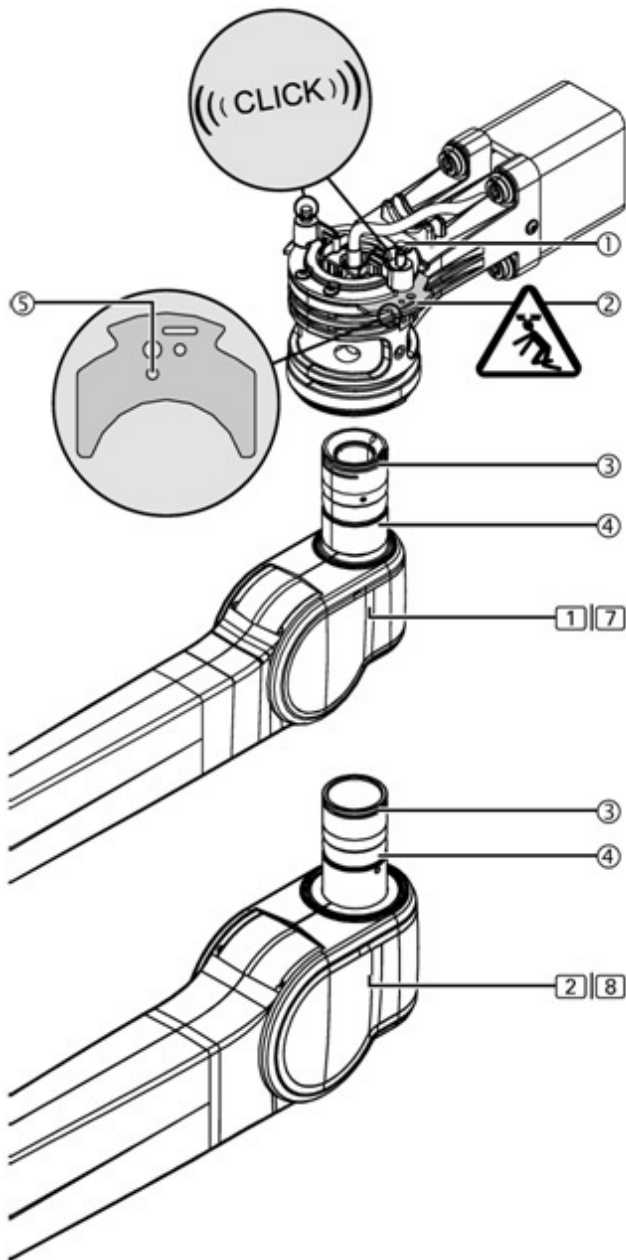

Figure 8: Mounting the L17 and LCH Spring Arms

Two people are required to mount the Spring Arm. An equipment lift is highly recommended to avoid injury in lifting the Spring Arm into place.

1. Pull the 2 latch pins ① upwards and route the 2 securing segments ② out of the Extension Arm until they snap into place ⑤.
2. Insert the Spring Arm pivot ④ straight into the Extension Arm up to the end stop without twisting.
 - The plug couplings mounted inside the Extension Arm and Spring Arm are connected during this installation step.
3. Insert 2 securing segments ② into the Extension Arm up to the end stop such that they snap into place:
 - The 2 securing segments ② must protrude into the groove ③ on the Spring Arm pivot ④
 - The 2 spring-actuated latch pins ① audibly click into place.

***** Risk of the Light Head dropping *****

If the 2 securing segments ② are not properly mounted, there is a risk of the Spring Arm with the Light Head dropping and causing serious injury. Check the 2 securing segments ② are securely in place:

- The Spring Arm must be inserted into the Extension Arm up to the end stop.
- The 2 securing segments ② must be inserted into the Extension up to the end stop such that they protrude into the groove ③ on the Spring Arm pivot ④.
- The 2 latch pins ① must audibly snap into place and be on the same height after the installation.

Mounting the MD21/MD21+ Spring Arm

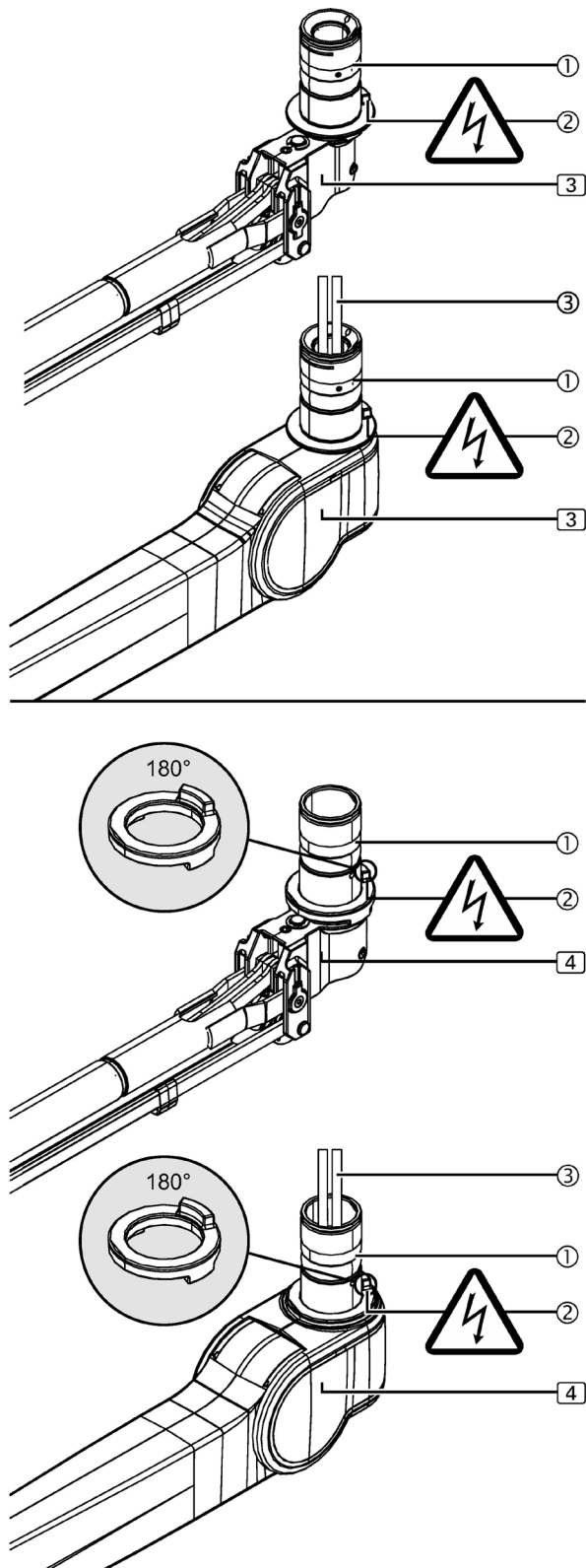

Figure 9: Mounting the MD21/MD21+

The Figure shows the MD21 Spring Arm [3] and the MD21+ Spring Arm [4] without and with covers. The Spring Arms have different geometry. The installation procedure is identical. The end stop ② must be mounted for all Spring Arm versions with cables.

Electrical shock hazard

The Spring Arm with cables ③ must be fitted with an end stop ② (twist protection) which restricts the swivel range of the Spring Arm. If the end stop ② is not mounted, the cables are twisted off and the Arm System is energized. Contact with energized components present danger to life from electrical shock;

- Check that the end stop ② is mounted to the Spring Arm.
- For the MD21+ [4] the end stop ② from the accessories must be mounted.
- The Spring Arm must not be mounted without an end stop ②

Only for the MD21 with cables ③ or optionally for versions without cables ③

1. Check that the end stop ③ is pre-assembled on the Spring Arm pivot ①.
- The Spring Arm with cables ③ must not be mounted without the end stop ②.
 - If the end stop ② is not included in the accessories, contact Customer Service.

Only for the MD21+

1. Place the end stop ② onto the Spring Arm.
- The end stop ② can be rotated by 180°.
 - When rotating the end stop ②, the end stop area of the Spring Arm is rotated by 180°.
 - If the end stop ② is not included in the accessories, contact Customer Service.

***** Risk of the Monitor Arm dropping *****

If the 2 securing segments ② are not properly mounted, there is a risk of the Spring Arm with the Monitor Arm/Cradle dropping and causing serious injury. Check the 2 securing segments ② are securely in place.

Mounting the MD21 Spring Arm (cont)

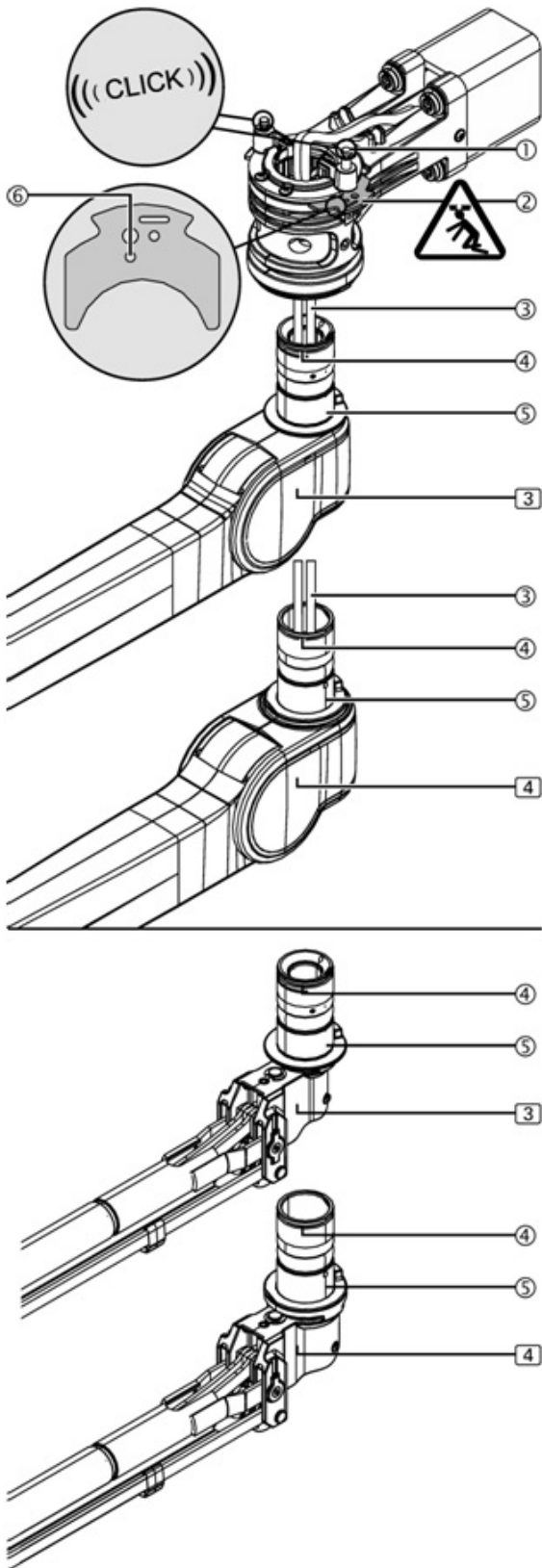

The figure shows the MD21 Spring Arm with and without the cover panels.

1. Route the pre-assembled cables ③ through the Extension Arm.
2. Pull the 2 latch pins ① upwards and route the 2 securing segments ② out of the Extension Arm until they snap in place ⑥.
3. Insert the Spring Arm pivot ⑤ straight into the Extension Arm up to the end stop without twisting.
4. Insert 2 securing segments ② into the Extension Arm up to the end stop such that it snaps in place:
 - The 2 securing segments ② must protrude into the groove ④ on the Spring Arm pivot ⑤
 - The 2 spring-actuated latch pins ① audibly click into place.

***** Risk of the Monitor Cradle dropping *****

If the 2 securing segments ② are not properly mounted, there is a risk of the Spring Arm with the Light Head dropping and causing serious injury. Check the 2 securing segments ② are securely in place:

- The Spring Arm must be inserted into the Extension Arm up to the end stop.
- The 2 latch pins ① must audibly snap into place and be on the same height after the installation

Preparing the MD21 Spring Arm

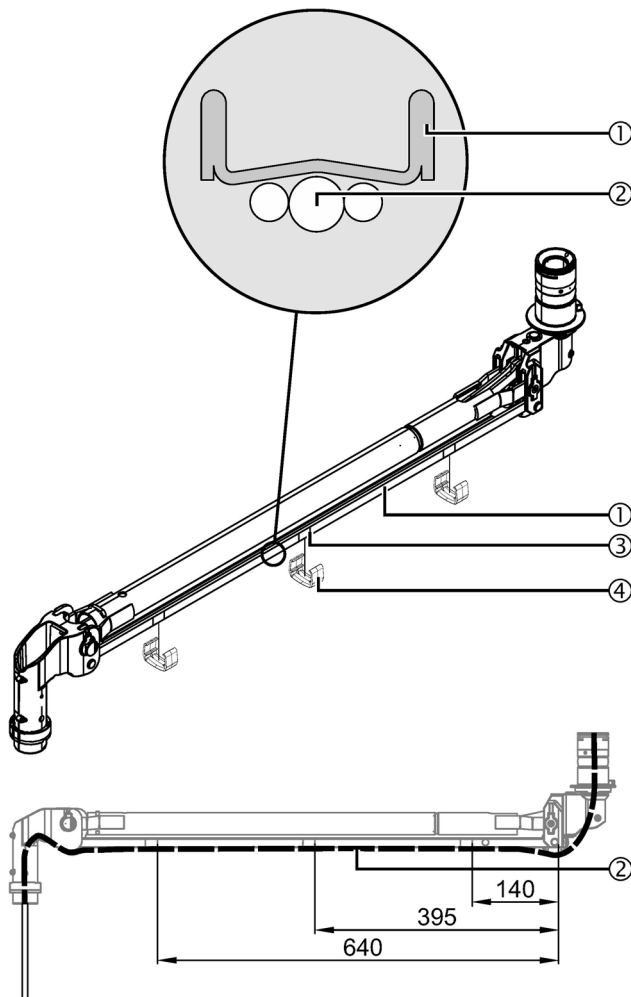

Figure 10: Mounting external cables

The Figure shows simplified illustrations which explain how to lay external cables (2) in the MD21 Spring Arm [3] (the joint securing device on the front joint is not shown). The steps for installing the Spring Arm are identical for the MD21 and the MD21+.

Marking the cable clips

1. Permanently mark the position (3) of the cable clips (4) on the parallel guide (1);
- The parallel guide of the Spring Arm starts at the reference edge for the dimensioned distances to the cable clips (4).
- If the 3 cable clips (4) are not mounted back to their previous positions, the side panels are pushed on and no longer flush with each other.
2. Disengage the 3 cable clips (4) laterally from the parallel guide using a suitable screwdriver and remove them.

Mounting Cables

1. Adjust the vertical lift of the Spring Arm to the lowermost horizontal (0°).

***** Warning *****

Electrical Shock Hazard

If the external cables (2) are not laid next to each other and without twisting or if the external cables (2) are damaged, the Arm System is energized. Contact with energized components presents a danger to life from electrical shock.

- Make sure that you lay the external cables (2) next to each other and without twisting
- Do not damage the cable insulations.

***** Warning *****

Damaged external cables (2) can energize the Arm System.

- Check all external cables (2) for damage. Make sure you insert them with great care without cables/tubes crossing each other without loops and without twisting.
 - Do not damage the cable insulation
2. Route the external cables (2) towards the parallel guide (1) at the bottom of the Spring Arm and then route them through the Spring Arm next to each other and without twisting as illustrated in the Figure.
 - To do this, make sure that you centrally lay the external cable with the largest cross section as illustrated in the Figure.

Preparing the MD21 Spring Arm (cont)

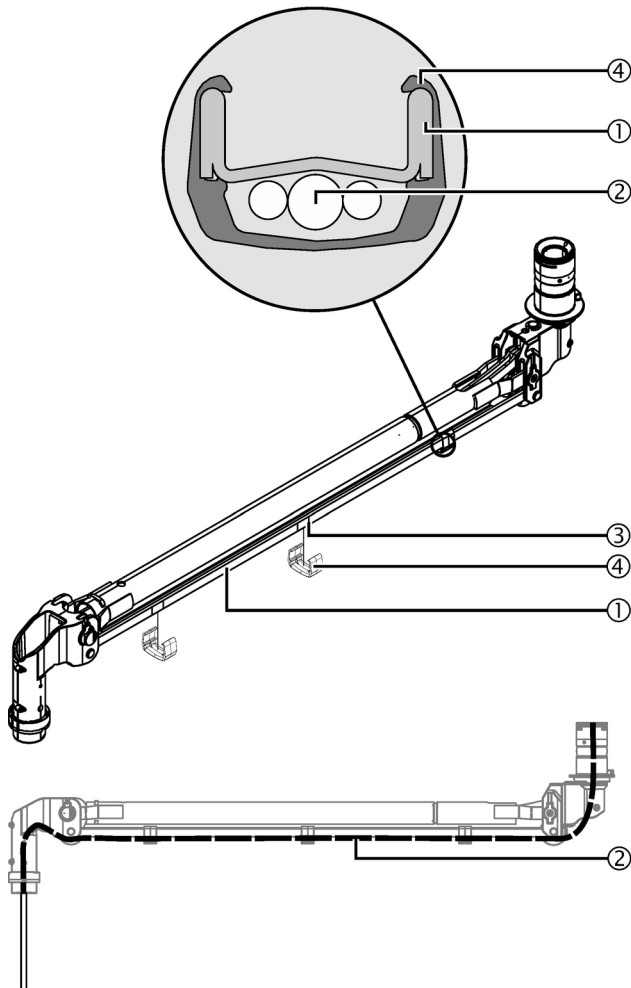
**Fixing the cables**

1. Click 3 cable clips (4) onto the previously marked positions (3) on the parallel guide (1) ;
- If the 3 cable clips (4) are not mounted back to their previous positions, the side panels are pushed on and no longer flush with each other.

***** Warning *****

Damaged external cables (2) can energize the Arm System.

- Lay the external cables (2) in the Spring Arm in such a way that they are not exposed to tensile stress in any position.
 - Do not damage the cable insulations.
 - When inserting or laying external cables (2) the permissible minimum deflection and bending radii and the permissible maximum tensile stress values must be observed. The specifications of the corresponding cable manufacturer must be adhered to.
2. Check the clearance of the external cables (2);
 - The external cables (2) must be laid to the front and rear joint of the Spring Arm with a slight, strain free curvature.
 3. If required, extend the vertical lift of the Spring Arm in Section 6.
 - Check that the external cables (2) are not exposed to tensile stress and that the Spring Arm can be freely moved.

Preparing the L17 Spring Arm

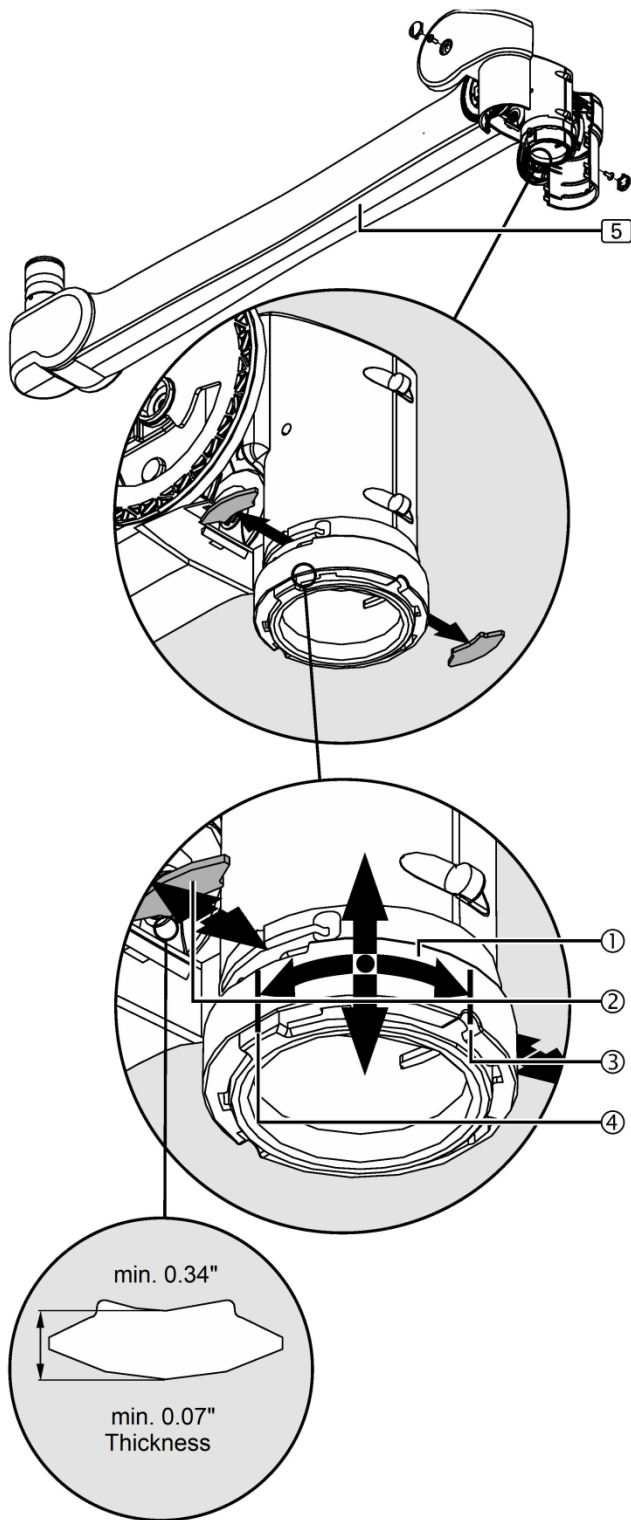

Figure 11: Preparing the L17 Spring Arm

The Figure shows a simplified illustration of the Spring Arm [5] without cables or Light Head.

***** Risk of the Light Head dropping *****

The Light Head is kept in its position in the Spring Arm by 2 securing segments. If both securing segments are dismantled simultaneously from the Spring Arm, there is a risk of the Light Head dropping out of the Spring Arm and causing severe injury;

- **Dismantle the securing segments one at a time.**

Dismantling the first securing segment

1. Rotate the segment securing device ① approximately 90° to the right, route it slightly downwards and then remove the first securing segment ②.
- To do this, cover the second securing segment on the opposite side with your hand in order to prevent it from dropping out of the Spring Arm.
2. Remove the second securing segment in the same manner.
3. Route the segment securing device ① back upwards.

Mounting the Light Head to L17 Spring Arm

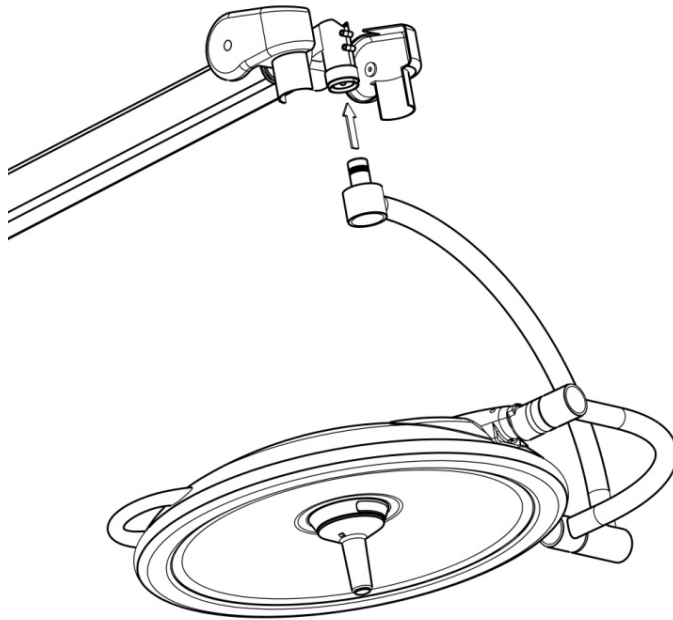

Figure 12: Mounting the Light Head

Note: For In-Light Camera Light Heads and Monitor Cradles, run the wires from the yoke pivot into the arm before installing the Light Head.

Installing the Light Head or the Monitor Cradle to the L17 Spring Arm requires two people to position the Light Head yoke or Monitor Cradle pivot into the receptacle.

Use the detail illustrations on the previous page

- Remove the Plastic Covers from the Spring Arm
- Position the yoke pivot directly under the receptacle
- Lubricate the pivot on the Yoke (going into the Spring Arm) with white grease through the fitting aperture of the securing segment ②.
- Carefully slide the pivot into the receptacle.

***** Risk of the Light Head dropping *****

- Once the Light Head yoke pivot is in the L17 Spring Arm you are ready to install the two securing segment ②.

Mounting the first securing segment

1. Lubricate the securing segment ② with a White solid lubricant paste grease (white grease)
2. Route the segment securing device ① slightly downwards.
 - To do this, cover the second securing segment on the opposite side with your hand in order to prevent it from dropping out of the Spring Arm.
3. Place the securing segment ② and route the segment securing device ① towards the top and then rotate it approximately 90° to the left.
 - The cutout ③ in the segment securing device ① must protrude over the optional brake screw or brake screw hole ④.
4. Check that the securing segment ② is securely in place;
 - The Light Head/Yoke Assembly or the Monitor Cradle must rotate freely.

Checking the second securing segment

5. Dismantle and check the second securing segment as described in Section 6.
6. Re-mount the second securing segment.

Adjusting the vertical lift and the optional brake

- Adjust the vertical lift of the Spring Arm as described in Section 5.
- Mount the cover panels to the Spring Arm.

Preparing the LCH Spring Arm

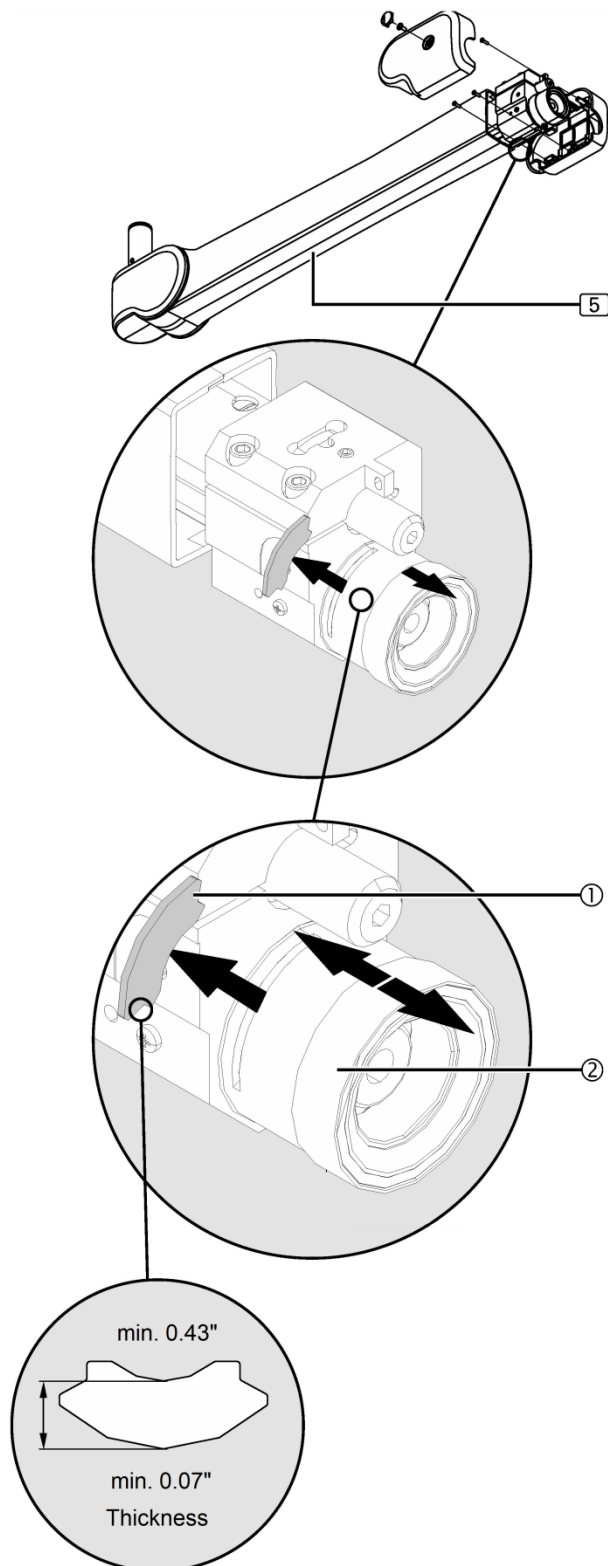

Figure 13: Preparing the LCH Spring Arm

The Figure shows a simplified illustration of the Spring Arm [5] without cables or Light Head.

Remove the Plastic Covers as shown

***** Risk of the Light Head dropping *****

The Light Head is kept in its position in the Spring Arm by ① securing segment. If the securing segment is dismantled, there is a risk of the Light Head sliding out of the Spring Arm, dropping and causing severe injury;

- To dismantle the securing segment, route the adaption with the Light Head/Yoke Assembly or Monitor Cradle out of the Spring Arm.

Moving the segment securing device

1. Unscrew the Phillips recessed head screw ③.
2. Push the segment securing device ② forwards until the securing segment ① is accessible.
3. Slightly unscrew the optional brake screw

Dismantling the securing segment

4. Remove the securing segment ① and position the Light Head/Yoke Assembly or Monitor Cradle out of the Spring Arm. [5]. Check whether the securing segment ① achieves a minimum thickness of 0.07" (1.8mm) and a minimum length of 0.43" (10.9mm); otherwise, replace the securing segment.

Mounting the Light Head to LCH Spring Arm

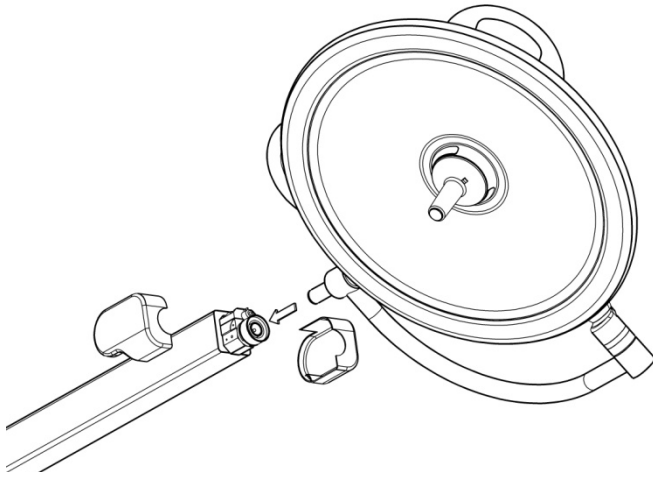

Figure 14: Mounting the Light Head to an LCH Arm

Installing the Light Head into the LCH Spring Arm requires two people to position the Light Head yoke pivot into the receptacle.

Use the detail illustrations on the previous page

***** Risk of the Light Head dropping *****

- Align the yoke pivot to the receptacle on the LCH Spring Arm.
- Lubricate the pivot on the Yoke (going into the Spring Arm) with white grease through the fitting aperture of the securing segment ②.
- Carefully insert the pivot into the receptacle until it stops.
- Once the Light Head yoke pivot is in the LCH Spring Arm you are ready to install the securing segment ②.

Mounting the securing segment

1. Lubricate the securing segment ① with white grease.
2. Lubricate the pivot of the Light Head/Yoke Assembly or the Monitor Cradle with white grease.
3. Insert the Pivot on the Light Head/Yoke into the Spring Arm assuring the groove in the yoke pivot aligns with the securing segment slot in the arm. Once alignment is achieved, insert the securing segment ①.
4. Check that the securing segment ① is securely in place;
 - The Light Head must rotate freely.

Moving the segment securing device

5. Re-tighten the optional brake screw
6. Push the segment securing device ② backwards and screw it on using 1 Phillips recessed head screw ③.

Adjusting the vertical lift and the optional brake

7. Adjust the vertical lift of the Spring Arm as described in Section 5;
 - Mount the cover panels to the Spring Arm.

Mounting the LCH Spring Arm with Camera

Remove Screws
(x4)

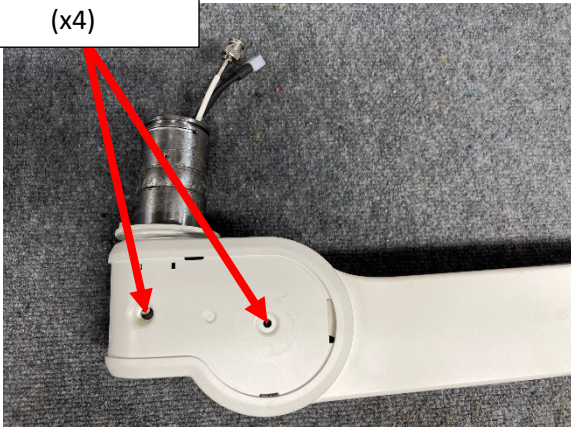

Figure 15: Preparing LCH Spring Arm with Camera - Screw Removal



Figure 16: Preparing LCH Spring Arm with Camera - Cover Removal



Figure 17: Mounting the LCH Spring Arm with Camera

Two people are required to mount the LCH Spring Arm with Camera. An equipment lift is highly recommended to avoid injury in lifting the Spring Arm into place.

1. Prepare the LCH Spring Arm with camera by removing all covers. To do this, remove the four screws securing the elbow covers and gently pull the two halves apart. With the elbow cover removed, the plastic covering running the length of the spring arm can now be pulled apart.
2. The LCH Spring Arm with camera can now be mounted to the central axis. Refer to Section 4 Mounting the L17 and LCH Spring Arm for instructions on how to safely mount the Spring Arm.

***** Risk of the Light Head dropping *****

If the 2 securing segments are not properly mounted, there is a risk of the Spring Arm with the Light Head dropping and causing serious injury. Check the 2 securing segments are securely in place:

- The Spring Arm must be inserted into the Extension Arm up to the end stop.
- The 2 securing segments must be inserted into the Extension up to the end stop such that they protrude into the groove on the Spring Arm pivot.
- The 2 latch pins must audibly snap into place and be on the same height after the installation.

Mounting the Light Head to the LCH Spring Arm with Camera

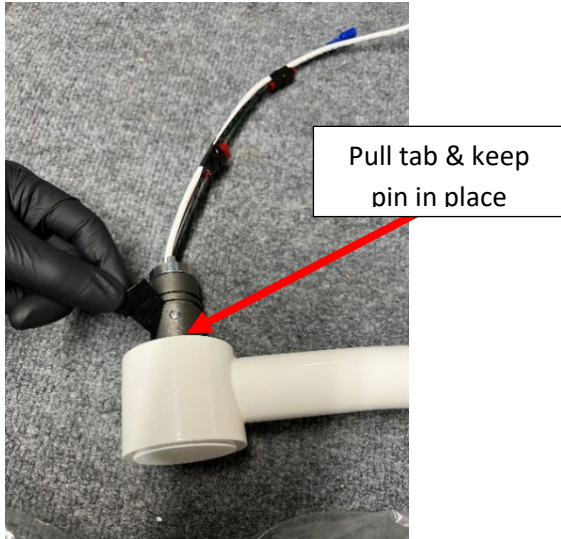

Figure 18: Prepare the Light Head to Mount to the LCH Spring Arm with Camera



Figure 19: LCH Light Head with Camera Install

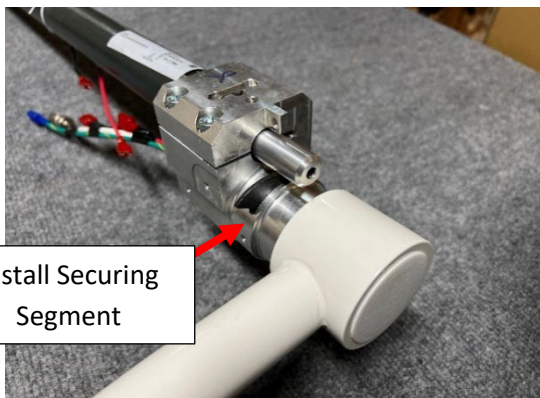

Figure 20: LCH Light Head with Camera - Install Securing Segment

Two people are required to mount the LCH Light head with Camera. An equipment lift is highly recommended to avoid injury in lifting the Spring Arm into place.

1. Prepare the light head by removing the tape from the yoke pivot. Pull the tab on the tape being sure the pin stays in place.
2. Begin by inserting each of the four wires from the yoke one at a time, until all four connectors are clear.

Section 4

Positioning the Light

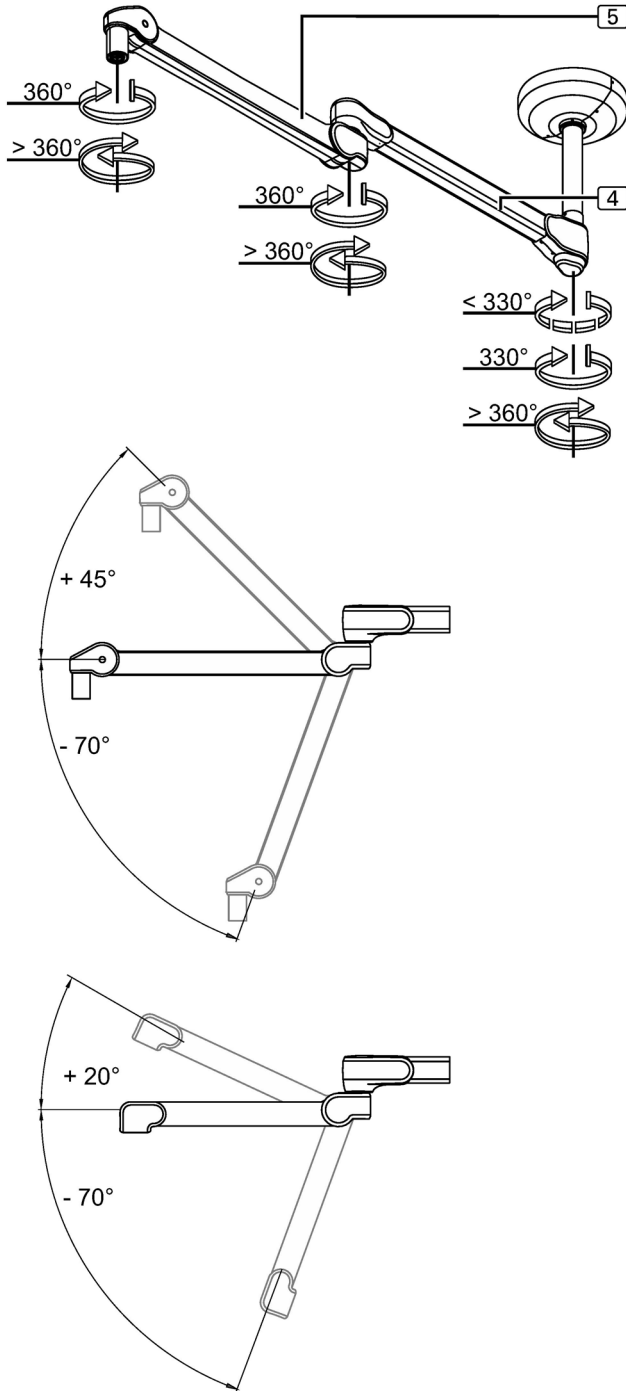

Figure 21: Positioning the Arms

Positioning the Arm System

The Figure illustrates the configuration example of the VistOR MS LED central axis S1.

The Extension Arm [4], Spring Arm [5] and the Light Head or Monitor can be positioned easily. The swivel range and the vertical lift can be restricted through internal end stops.

- Arms with standard Light Heads have continuous rotation
- Arms with Monitor Cradles or with Light Heads with In-Light Cameras have rotational stops to prevent the wires from being damaged during use.

Swiveling the Arm System

***** Notice *****

To prevent damage to the Arm System;

- Do not hit the end stops hard
- Avoid collisions with other components.
- Slowly swivel the Light Head
- Depending on the individual version the swivel range ends at the internal end stops of the Extension Arm [4] and the Spring Arm [5].

Adjusting the Height of the Arm System

***** Notice *****

If the Light Head or Monitor is moved upwards, there is a risk that it could collide with other components.

- Prior to adjusting the height, check for potential risks of collision.
- Slowly adjust the height of the Light Head.
- The height adjustment is restricted by the internal end stops of the Spring Arm [5]. If the Extension Arm [4], the Spring Arm [5], the Light Head do not remain stable in the set position, the spring tension or brake force must be adjusted.

Section 5: Adjustments

Adjusting the Brakes for the Extension Arm

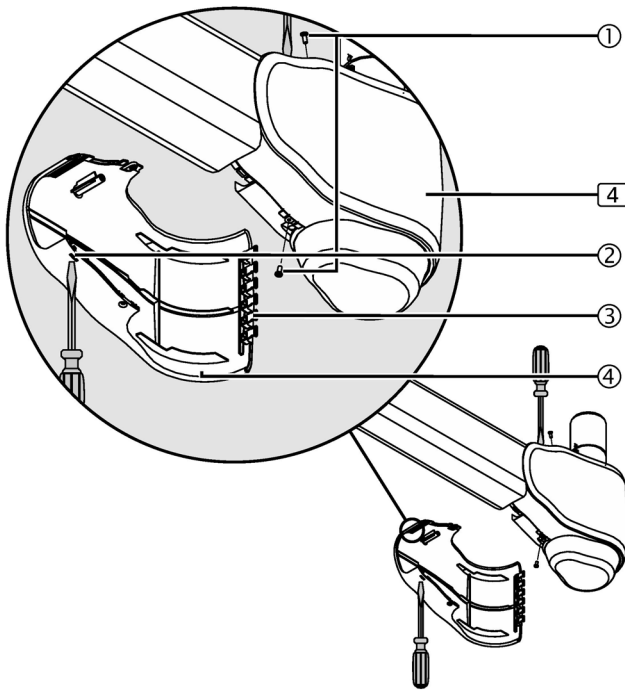

Figure 22: Dismantling the right-hand cover panels from the Extension Arm

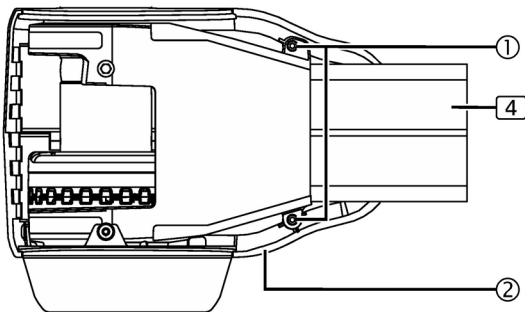

Figure 23: Dismantling the left-hand cover panel from the Extension Arm

To adjust the brakes, the cover panels must be dismantled from the corresponding Extension Arm [4].

The dismantling of the cover panels is described using the example of the VistOR MS LED central axis S1. The installation procedure for further versions is identical.

Follow the safety instructions on Page 56.

Dismantling the cover panels on the right-hand side from the Extension Arm

1. Unscrew the 2 PT Torx screws ① from the top and bottom sides of the left-hand Extension Arm cover panel.
 2. Insert a suitable slotted screwdriver into the fitting aperture in the right-hand Extension Arm cover from below and disengage it by gently pushing it in.
 3. Insert a suitable slotted screwdriver into the fitting aperture of the left-hand Extension Arm from above and disengage it by gently pushing it in.
 4. Disengage the right-hand Extension Arm cover panel ④ from the edge of the connection of the 2 Extension Arm cover panels.
 5. Gently remove the right-hand Extension Arm cover panel from the Extension Arm [4].
- To do this, gently disengage the latches ③.

Dismantling the left-hand cover panel from the Extension Arm

1. Unscrew the 2 PT Torx screws from the left-hand Extension Arm panel.
2. Gently remove the left-hand Extension Arm cover ② from the Extension Arm [4].

Adjusting the Brakes for the Extension Arm (cont)

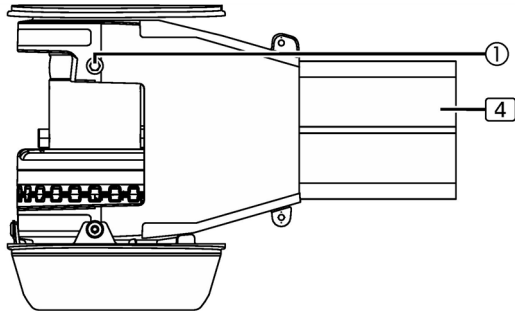

Figure 24: Adjusting the Extension Arm brakes

The adjustments of the brakes are illustrated using the example of the VistOR MS LED central axis S1 version. The installation procedure for further versions is identical.

Follow the safety instructions on Page 56.

Position and number of brake screws

- Each Extension Arm [4] is fitted with 2 brake screws ① positioned opposite to one another.

Adjusting the brakes

- Adjust the brakes such that the Extension Arm 4 remains stable in any set position and can still be conveniently adjusted.

- Use an Allen key (size 5).

To increase the brake force

- Insert the Allen key into the brake screws and alternately turn with the same number of revolutions in the clockwise direction as illustrated in the Figure.

To reduce the brake force

- Insert the Allen key into the brake screws and alternately turn with the same number of revolutions in the counterclockwise direction as illustrated in the Figure.

Perform a function test.

Adjusting the Brakes for the Extension Arm (cont)

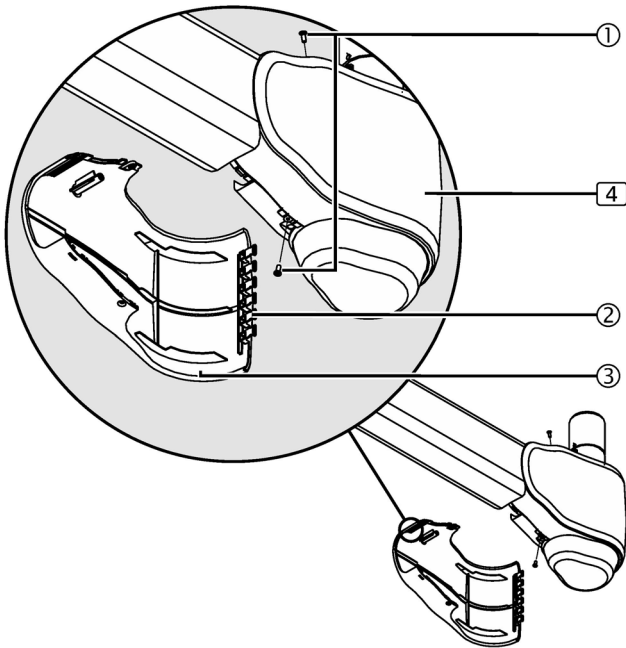

Figure 25: Mounting the right-hand cover panel to the Extension Arm

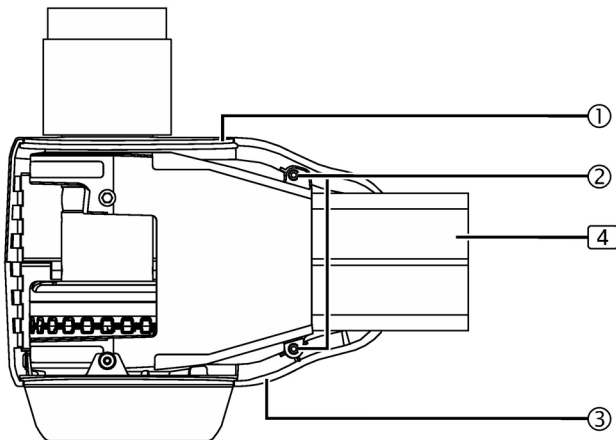

Figure 26: Mounting the left-hand cover panel to the Extension Arm

Mounting the right-hand cover panel to the extension

Mounting the rear cover panels to the Extension Arm

The mounting of the cover panels is illustrated using the example of the VistOR MS LED central axis S1 version. The installation procedure for further versions is identical.

Follow the safety instructions on Page 56.

Mounting the left-hand cover panel to the Extension Arm

1. Position the left-hand Extension Arm cover panels (3) on the Extension Arm such that the top cover panel (1) sits in the Extension Arm cover (3).
2. Tighten the left-hand Extension Arm cover panel (3) using 2 PT Torx screws (2).

Mounting the right-hand cover panel to the Extension Arm

1. Place the right-hand Extension Arm cover panel (3) into the left-hand Extension Arm cover panel.
 - Make sure that the rear latches (2) engage with each other in a 90° angle and then close the Extension Arm cover panels like a hinge.
2. Screw the right-hand Extension Arm cover panel (3) onto the top and bottom sides of the left-hand Extension Arm cover panel using 2 PT Torx screws (1).
3. Check that the Extension Arm cover panels are securely in place;
 - The Extension Arm cover panels must engage tightly with each other without gaps.
 - The 2 PT Torx screws (1) – must be tightened.

Adjusting the Brakes for the Spring Arm

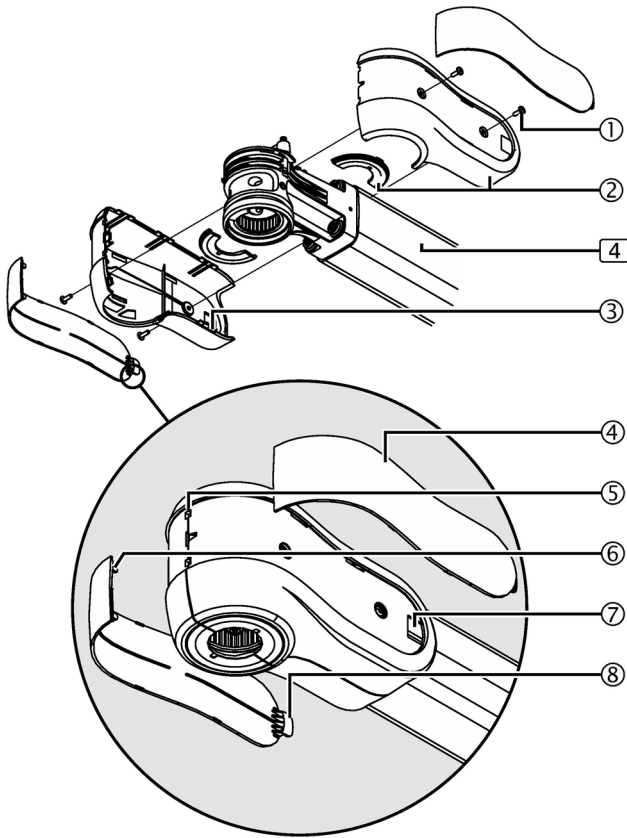

Figure 27: Dismantling the decorative caps and socket covers

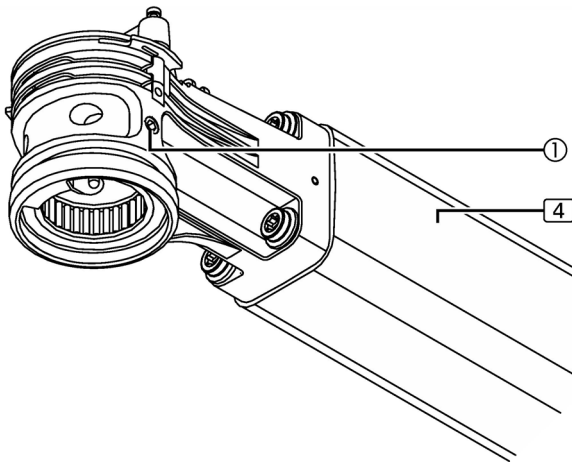

Figure 28: Adjusting the brakes

The above figures show simplified illustrations of the Extension Arm without the Spring Arm.

To adjust the brakes the front socket covers must be dismantled from the corresponding Extension Arm [4].

Follow the safety instructions on Page 56.

Dismantling the decorative caps

1. Simultaneously push the 2 decorative caps (4) forwards in order to route the 2 straps (8) out of the cutouts (7).
2. Gently disengage the locking pins (6) on the decorative caps (4).
3. Gently route the decorative caps (4) out of the 2 holes (5) on the socket covers (2) and remove them.

Dismantling the socket covers

1. Unscrew 2 cross recessed head screws (1) from the right- and left-hand socket cover (2).
2. Gently disengage the locking pins (3) and remove the right- and left and socket cover with optional cover plates (2).

Adjusting the brakes

Position and number of brake screws

- Each Extension Arm [4] is fitted with 2 brake screws (1) positioned opposite to one another.

Adjusting the brakes

- Adjust the brakes such that the Spring Arm remains stable in any set position and can still be conveniently adjusted.

Tool to be used

- Use an Allen key (size 5) to increase the brake force
- Insert the Allen key into the brake screws (1) and alternately turn with the same number of revolutions in the clockwise (+) direction as illustrated in the Figure.

To reduce the brake force

- Insert the Allen key into the brake screws (1) and alternately turn with the same number of revolutions in the counterclockwise (-) direction as illustrated in the Figure.

Perform a functionality test.

Adjusting the Brakes for the Spring Arm (cont)

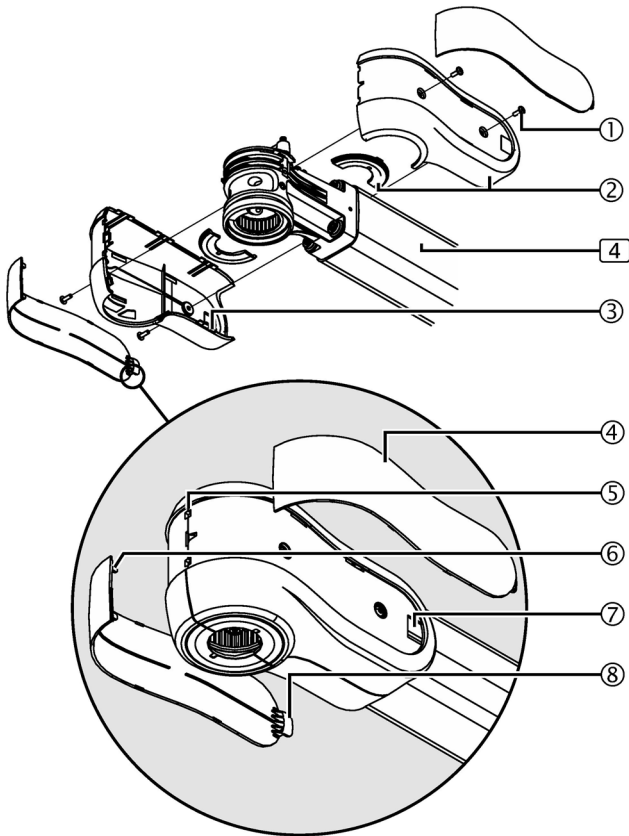

Figure 29: Mounting the socket covers and decorative caps to the Extension Arms

The Figure shows a simplified illustration with only the Extension Arm [4] without Spring Arm.

Mounting the socket covers to the Extension Arm

1. Screw the left-hand socket cover with optional cover plate ② onto the Extension Arm [4] using 2 cross recessed head screws ①.
2. Place the right-hand cover panel with optional cover plate onto the left-hand socket cover ② such that all the locking pins ③ engage with each other and screw it onto the Extension Arm [4] using 2 cross recessed head screws ①.
3. Check that the socket cover with optional cover plates is securely in place;
 - The socket covers with optional cover plates ② must tightly engage with each other without gaps and be tightened with 2 cross recessed head screws ①.

Mounting the decorative caps

***** Notice *****

To prevent damage to the decorative caps;

- The mounting steps described below must be executed in the correct order:
 1. Attach the locking mechanisms ⑥ of the decorative caps ④ into the 2 fittings ⑤ on the socket covers ②.
 2. Fold the decorative caps ④ towards the Extension Arm [4] and insert the straps ⑧ into the cutout ⑦ on the socket covers ②.
 3. Check that the decorative caps ④ are securely in place;
 - The decorative caps ④ must securely engage in the socket covers ② without gaps.

Adjusting the Comfort Stop on the Extension Arm

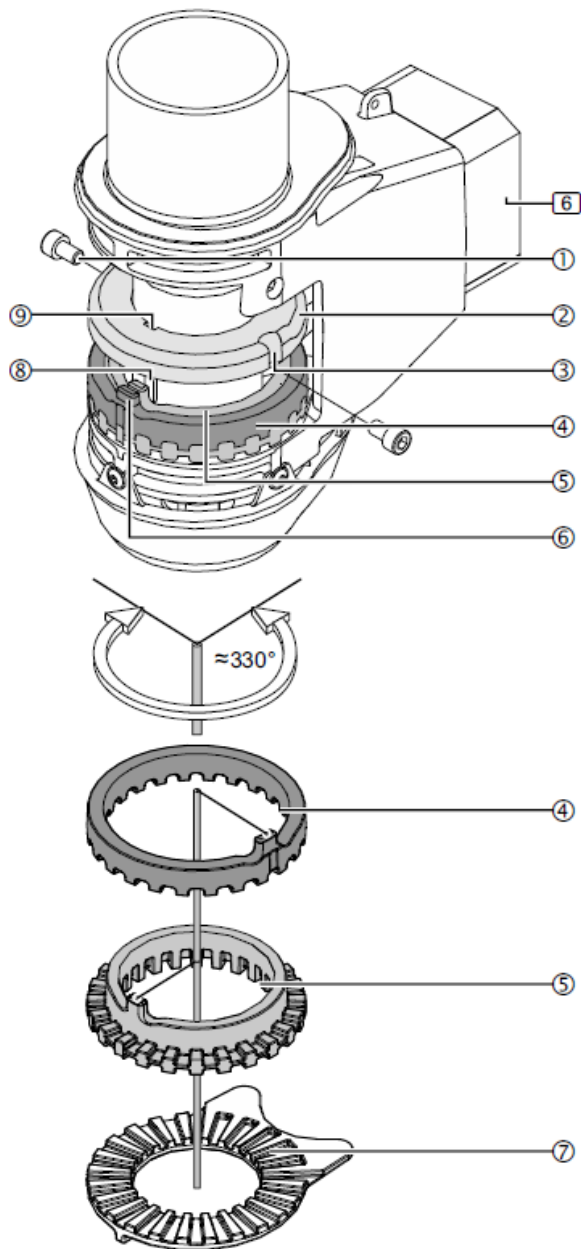

Figure 30: Adjusting the Comfort Stop end stop on the Extension Arm

The adjustment of the comfort end stop is illustrated using the example of the Single Extension Arm. The procedure for the multiple arm versions is identical. The comfort end stop can be separately adjusted for each Extension Arm. The minimum, reduced swivel range is 15°.

Dismantling the rear cover panels from the Extension Arm.

4. Dismantle the Extension Arm covers as described on Page 40 and the following pages.

Prepare the adjustment

5. Rotate the Extension Arm [6] such that the 2 Allen Screws are accessible.
6. Unscrew the 2 Allen screws ①.
7. Rotate the Extension Arm [6] in position such that the recess ③ in the end stop ring ② is visible.

Restricting the clockwise rotation of the Extension Arm

The swivel range of the Extension Arm [6] is defined by the position of the 3 end stops ② / ④ / ⑤ engaged tightly with each other.

8. Push the end stop ring ② out of the 2 fit-in keys (8) towards the top and slightly rotate it such that it is positioned on top of the fit-in keys ⑧.
9. Rotate the Extension Arm [6] into the first end stop position.
10. Lift the end stops ④ / ⑤ together and rotate them in position such that the 2 end stop pins ⑥ are positioned on the right-hand side of the recess ③ in the end stop rings.
11. Lower the end stops ④ / ⑤ such that the teeth protrude into the fixed compensating disc ⑦.
12. Rotate the end stop ring ② slightly backwards in order to be able to insert the groove ⑨ of the end stop ring ② into the 2 fit-in keys ⑧ and lower the end stop ring ② once again.
13. Next, rotate the Extension Arm [6] clockwise in order to check the end stop position.
 - Repeat the steps in order to readjust the end stop if required.

Continue on the next page

Adjusting the Comfort Stop on the Extension Arm- (cont)

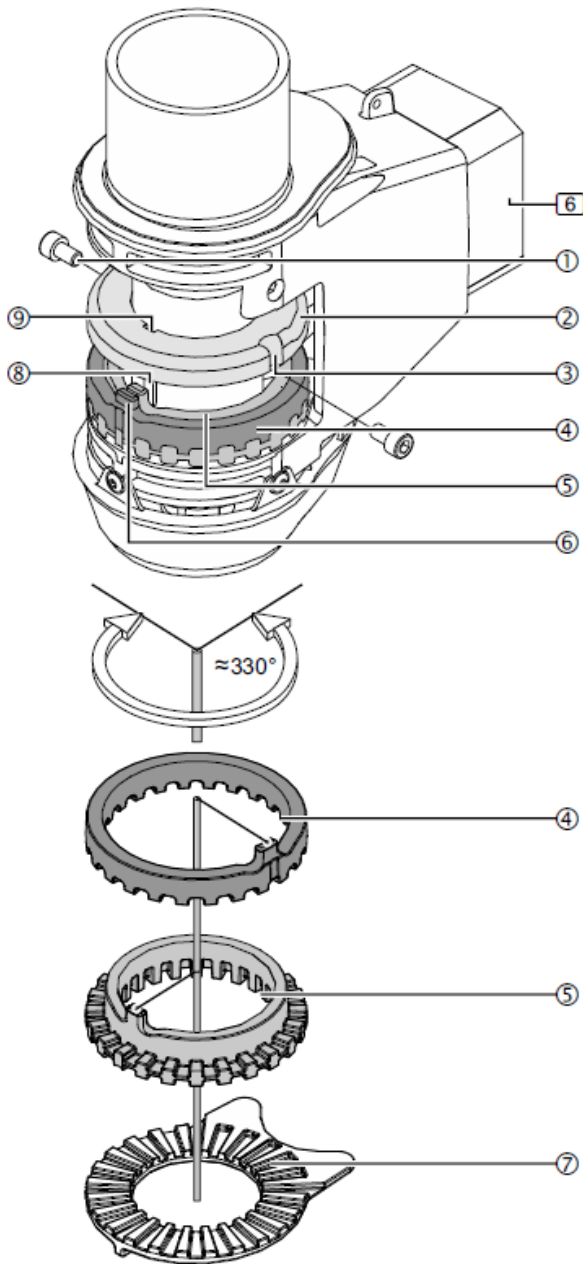

The swivel range of the Extension Arm [6] is defined by the position of the 3 end stops ② / ④ / ⑤ engaged lightly with each other.

14. Push the end stop ring ② out of the 2 fit-in keys ⑧ towards the top and slightly rotate it such that it is positioned on top of the fit-in keys ⑧.
15. Rotate the Extension Arm [6] into the second end stop position desired.
16. Lift the end stop ④ and rotate it in position such that the end stop pin ⑥ sits to the left of the recess (3) of the end stop ring ②.
17. Lower the end stop ④ such that the teeth protrude into the fixed compensating disc ⑦.
18. Rotate the end stop ring ② slightly backwards in order to be able to insert the groove (9) of the end stop ring ② into the 2 fit-in keys ⑧ and lower the end stop ring ② once again.
19. Next, rotate the Extension Arm [6] anti-clockwise in order to check the end stop position.
 - Repeat the steps in order to readjust the end stop if required.

Reversing the movement range by 180°

20. Since the 2 grooves ⑧ of the end stop ring ② sit opposite to each other, the end stop ring can be staggered by 180°.
 - By changing the position of the end stop ring ② its movement range is reversed.
21. Screw in and tighten 2 Allen screws ①.

Mounting the rear cover to the Extension Arm

22. Mount the rear cover panels to the Extension Arm as described on Page 40.

L21/MD21 Spring Arm

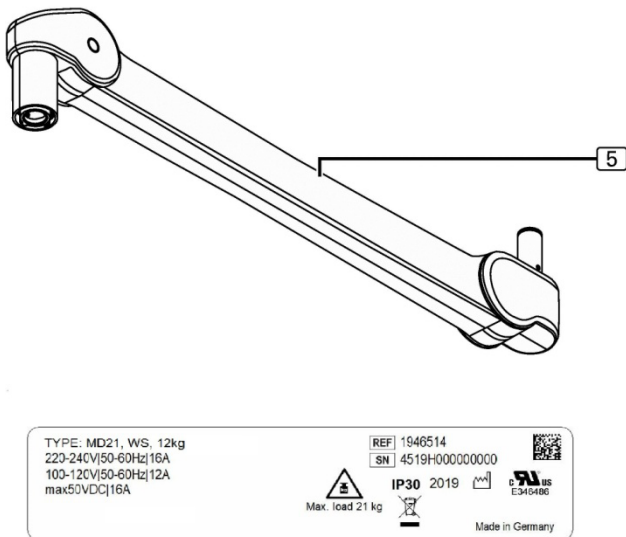
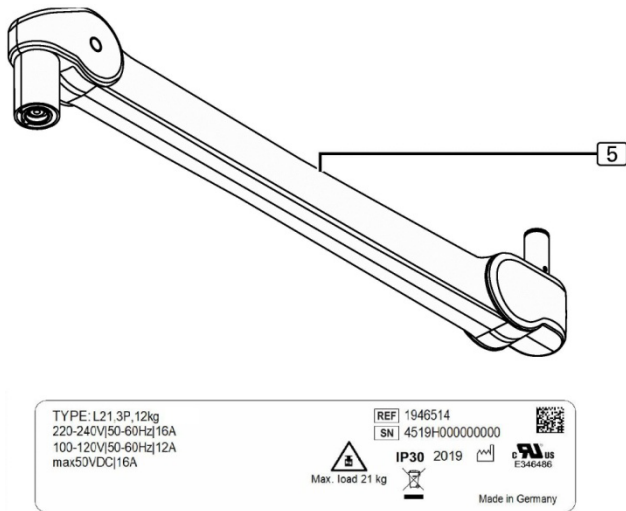

Figure 31: Spring Arm L21/MD21

VistOR MS LED Spring Arm L21/MD21

Identify the version of the Spring Arm [5] mounted according to the information on the rating plate.

The adjustment of the Spring Arms L21/MD21 is identical.

You can identify your VistOR MS LED Spring Arm L21 mounted by the TYPE designation: L21.

You can identify your VistOR MS LED Spring Arm MD21 mounted by the TYPE designation: MD21.

The rating plate is attached to the top side of the Spring Arm [5].

Adjusting the Spring Tension

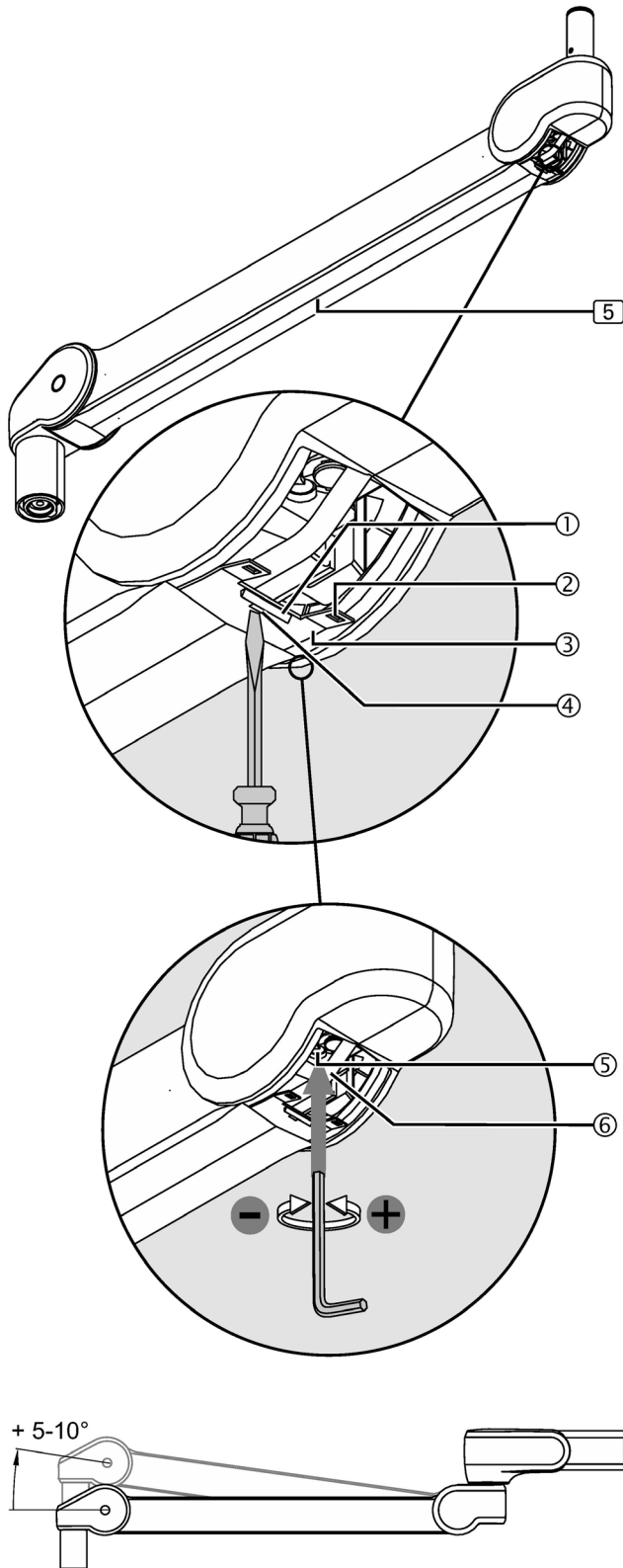

Figure 32: Adjusting the spring tension

The Spring Arm [5] is equipped with a spring which compensates the weight of the Light Head or the weight of a monitor.

Adjust the spring tension such that the Spring Arm with remains stable in any set position.

Follow the safety instructions on Page 56.

Disengaging the cover plate

1. Insert a suitable slotted screwdriver into the mounting aperture (4)
2. Slightly push the slotted screwdriver upwards and route the snap-in hook (1) out of the cover.
3. Push the slotted screwdriver with the cover plate (3) backwards.

Setting

- Use an Allen key (size 5).
- 4. Gently route any electric cables (6) towards the side and insert the Allen key into the adjustment aperture (5).
- Route the Spring Arm approximately +5° to +10° upwards in order to relieve the adjustment screw. If the Spring Arm moves down, the spring tension is too low
- Turn the Allen key to the left (counter-clockwise) as illustrated in the Figure. If the Spring Arm moves up, the spring tension is too high
- Turn the Allen key to the right (clockwise) as illustrated in the Figure.
- 5. Perform a function test.

Engaging the cover plate

6. Push the cover plate (3) forward and manually insert the 2 latches (2) into the cover panel.
7. Insert the slotted screwdriver into the hole (4), push the cover plate (3) slightly upwards and route the snap-in hook (1) into the cover panel.
8. Move the Spring Arm up & down and check that the cover plate (3) is securely in place.
- The snap-in hook (1) must sit in the cover panel.
- The cover plates must slide in the lateral guides without being trapped.

Adjusting the Vertical Lift

Figure 33: Adjusting the vertical lift

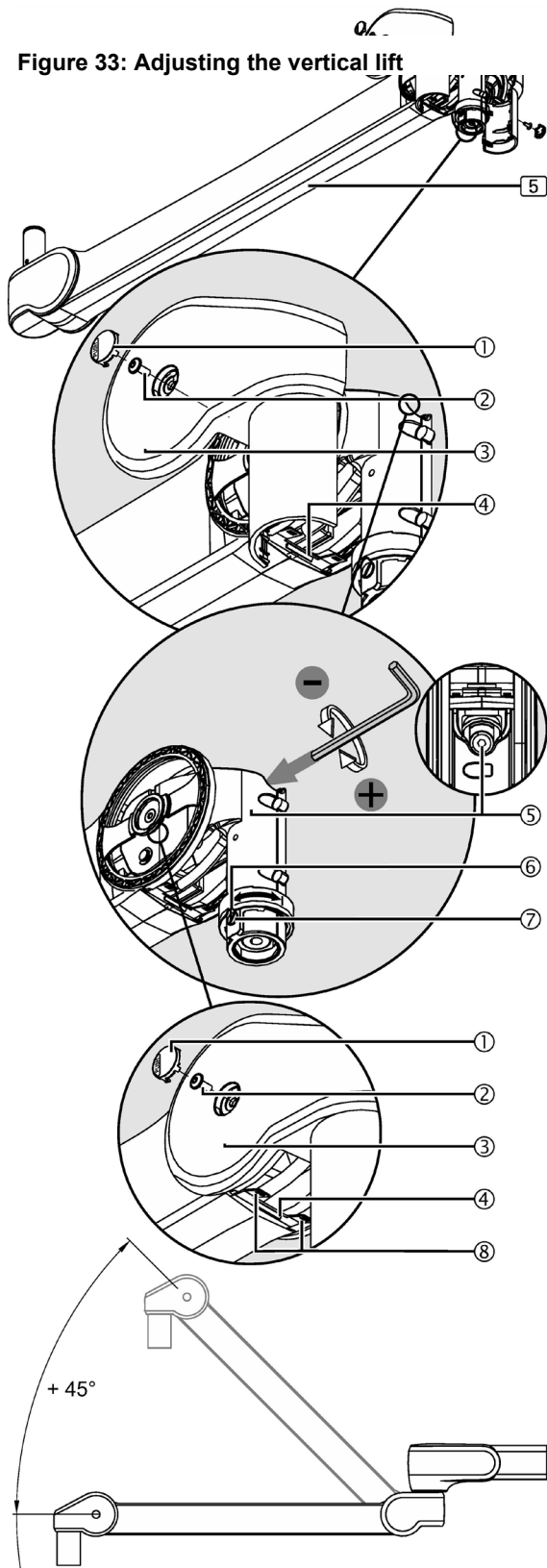

The vertical lift can be adjusted from approximately 0° to + 45° in the upwards direction.

Follow the safety instructions on Page 56.

Dismantling the cover panels and moving the cover plates

1. On each side push the PUSH button (1) labeled "PUSH" and accept.
2. Unscrew 1 cross recessed head screw (2) from each side.
 - Use a Torx T10 screwdriver.
3. Remove 1 cover panel (3) from each side.
 - To do this, gently disengage the latches.
4. Push the upper and lower cover plate (4) backwards.

Setting

- Use an Allen key (size 5).
- 5. Insert the Allen key into the adjustment hole (5).
- Slightly pull down the Spring Arm in order to relieve the adjustment screw in the Spring Arm.

To reduce the swivel range

- Turn the Allen key to the left (counter-clockwise) as illustrated in the Figure.

To extend the swivel range

- Turn the Allen key to the right (clockwise) as illustrated in the Figure.
6. Perform a function test.

Mounting the cover panels

7. Rotate the cutout in the segment securing device (6) such that it laterally protrudes over the optional brake screw or brake screw aperture (7).
8. Place 1 cover panel (3) on each side and screw it on using 1 cross recessed head screw (2).
 - To do this, gently engage the latches.
9. Insert one PUSH button (1) on each side such that it is flush with the cover panels (3).
 - The PUSH button (1) must not protrude.

Engaging the cover plates

10. Push the upper and lower cover plates (4) forwards and manually insert 2 latches (8) each into the cover panel's (3).
11. Using a suitable slotted screwdriver, push the cover plates' (3) further into the cover panels (3) until they audibly click into place.
 - The latches (8) of the cover plates (4) have now snapped into place.
12. Move the Spring Arm up and down and check that the cover plates' (4) are securely in place.
 - The cover plates must slide in the lateral guides without being trapped.

Adjusting the Optional Brake

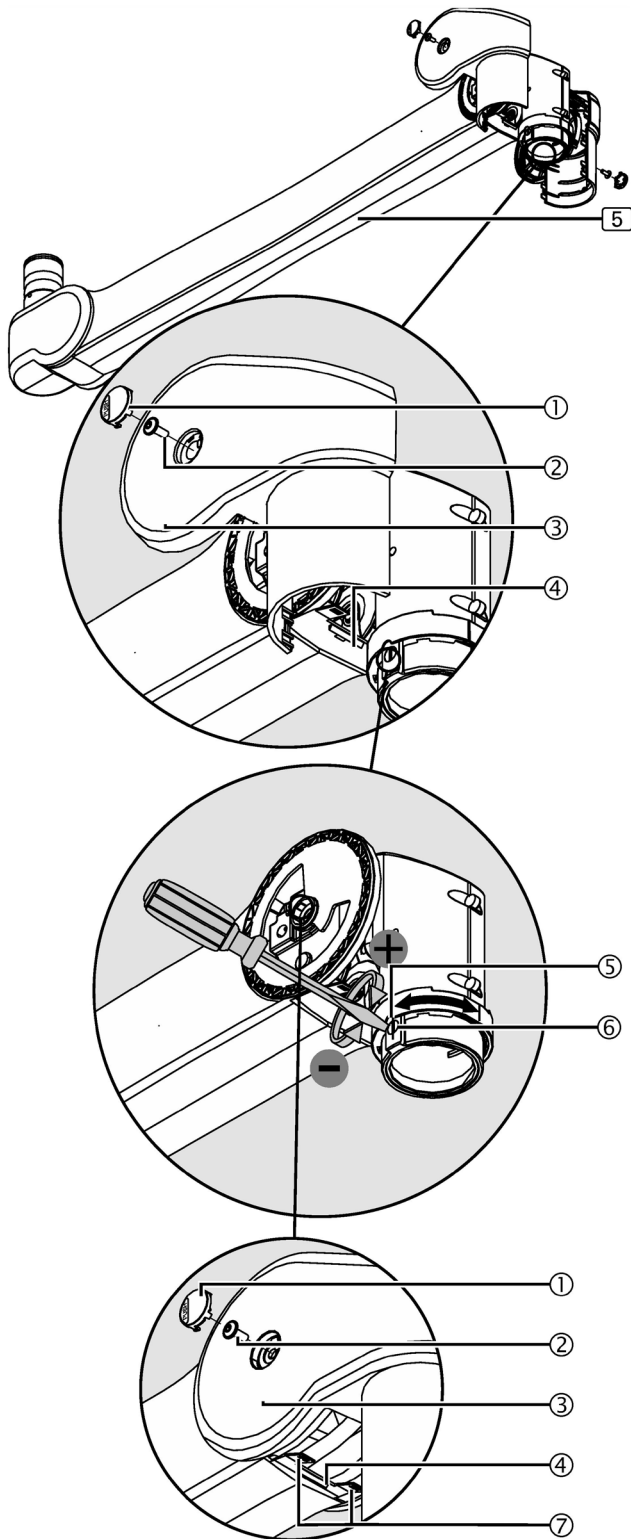

Figure 34: Adjusting the optional brake

Adjust the brakes such that the Light Head or Monitor remains stable in any set position and can still be conveniently adjusted.

Follow the safety instructions on Page 56.

Dismantling the cover panels and moving the cover plates

1. On each side push the PUSH button (1) labeled "PUSH" and accept.
2. Unscrew 1 cross recessed head screw (2) from each side.
 - Use a Torx T10 screwdriver.
3. Remove 1 cover panel (3) from each side.
 - To do this, gently disengage the latches.
4. Push the upper and lower cover plate (4) backwards.

Setting

- Use a suitable slotted screwdriver.

To increase the brake force

- Insert the slotted screwdriver into the brake screw (6) as illustrated in the Figure and turn it in the clockwise direction.

To reduce the brake force

- Insert the slotted screwdriver into the brake screw (6) as illustrated in the Figure and turn it in the counter-clockwise direction.
5. Perform a function test.

Mounting the cover panels

6. Rotate the cutout in the segment securing device (5) such that it laterally protrudes over the optional brake screw or brake screw aperture (6).
7. Place 1 cover panel (3) on each side and screw it on using 1 cross recessed head screw (2).
 - To do this, gently engage the latches.
8. Insert one PUSH button (1) on each side such that it is flush with the cover panels (3).
 - The PUSH button (1) must not protrude.

Engaging the cover plates

9. Push the upper and lower cover plates (4) forwards and manually insert 2 latches (7) each into the cover panels (3).
10. Using a suitable slotted screwdriver, push the cover plates (4) further into the cover panels (3) until they audibly click into place.
 - The latches (7) of the cover plates (4) have now snapped into place.
11. Move the Spring Arm up and down and check that the cover plates (4) are securely in place.
 - The cover plates must slide in the lateral guides without being trapped.

Adjusting the Vertical Lift – LCH Arm

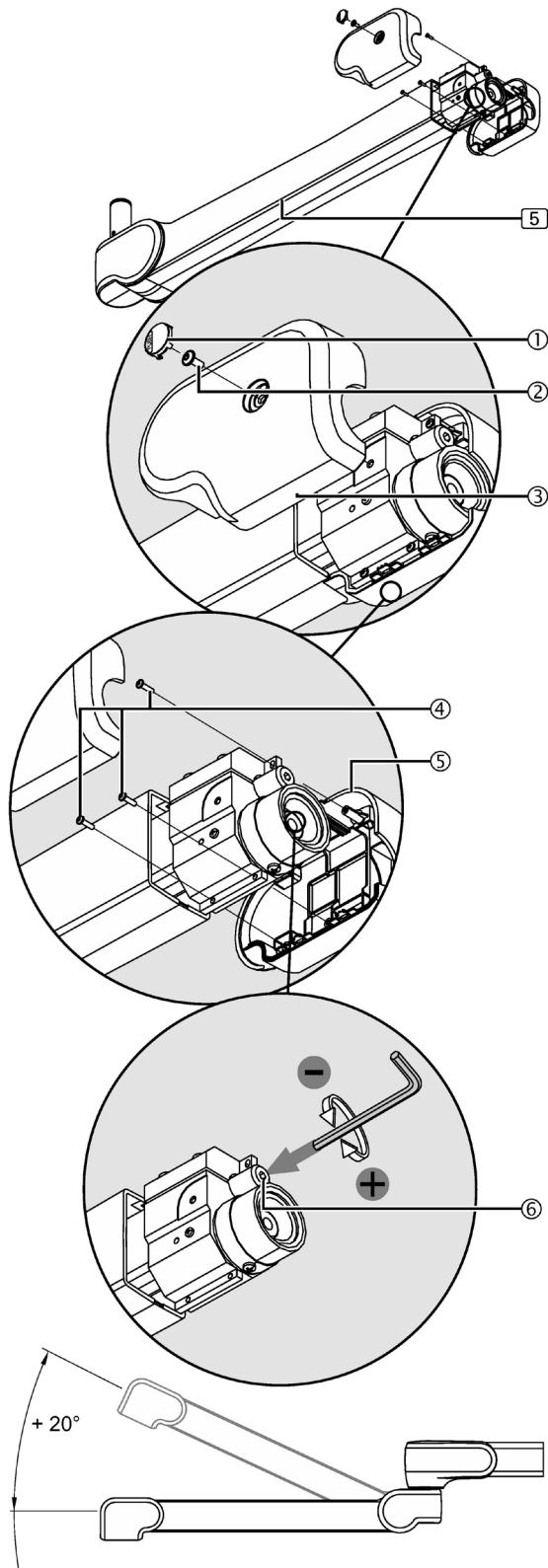

Figure 35: Adjusting the vertical lift

The vertical lift can be adjusted from approx. 0 to +20° in the upwards direction at maximum carrying load. It can be adjusted to up to +45° in the case of lower carrying loads.

Follow the safety instructions on Page 56.

Dismantling the left-hand cover panel

1. On the left-hand side push the PUSH button (1) labeled "PUSH" and accept.
2. Unscrew one cross recessed head screw (2).
 - Use a Torx T10 screwdriver.
3. Remove the cover panel (3).
 - To do this, gently disengage the latches.

Dismantling the right-hand cover panel

4. Unscrew the 3 PT Torx screws (4).
 - Use a Torx T10 screwdriver.
5. Remove the right-hand cover panel (5).

Setting

- Use an Allen key (size 5)
- 6. Insert the Allen key into the adjustment hole (6).
- Slightly pull down the Spring Arm in order to relieve the adjustment screw in the Spring Arm.

To reduce the swivel range

- Turn the Allen key to the left (counter-clockwise) as illustrated in the Figure.

To extend the swivel range

- Turn the Allen key to the right (clockwise) as illustrated in the Figure.
7. Perform a function test.

Mounting the right-hand cover panel

8. Place the right-hand cover panel (5) and screw it on using 3 PT Torx screws (4).

Mounting the left-hand cover panel

9. Place the left-hand cover panel (3) and screw it on using 1 cross recessed head screw (2).
 - To do this, gently engage the latches.
10. Insert the PUSH button (1) such that it is flush with the cover panel (3).
 - The PUSH button (1) must not protrude.

Adjusting the Optional Brake – LCH Arm

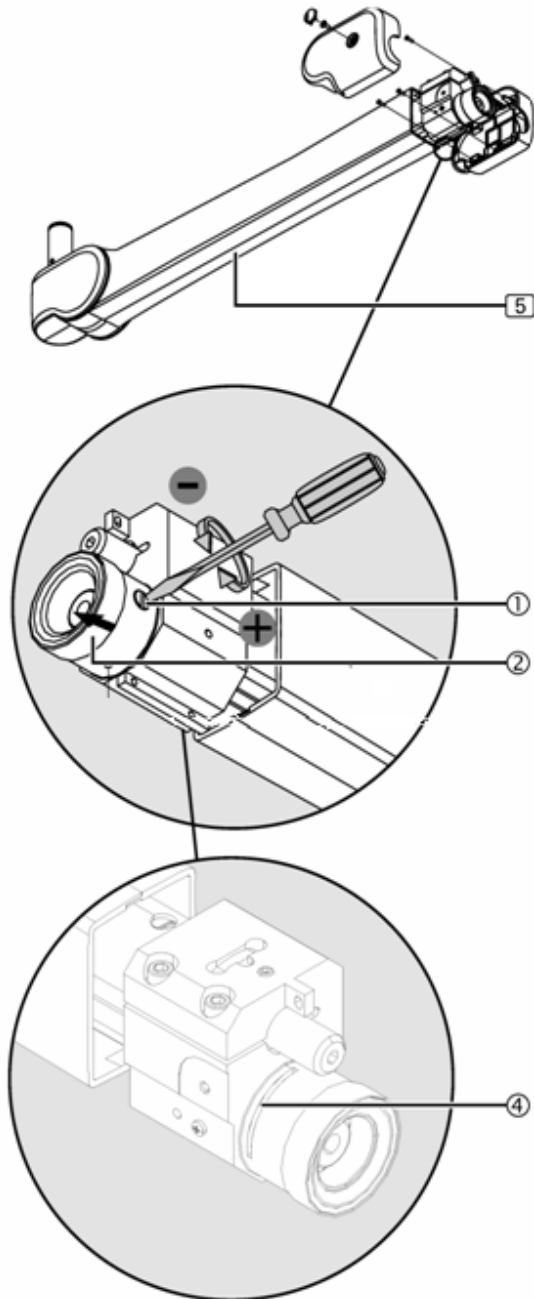

Figure 36: Adjusting the optional brake

Adjust the brakes such that the Light Head or Monitor remains stable in any set position and can still be conveniently adjusted.

Follow the safety instructions on Page 56.

Dismantling the cover panels

1. Dismantle the cover panels as previously described

Moving the segment securing device

2. Push the segment securing device (2) forwards until the brake screw is accessible.

Setting

- Use a suitable slotted screwdriver.

To increase the brake force

- Insert the slotted screwdriver into the brake screw (1) as illustrated in the Figure and turn it in the clockwise direction.

To reduce the brake force

- Insert the slotted screwdriver into the brake screw (1) as illustrated in the Figure and turn it in the counter-clockwise direction.

3. Perform a function test.

Moving the segment securing device

4. Push the segment securing device backwards and screw it on using 1 Phillips recessed head screw.
 - Make sure that the segment securing device does not protrude from the fitting aperture (4).

Mounting the cover panels

5. Re-mount the cover panels as illustrated.

Adjusting the Yoke Brake

In the event that the Light Head will not maintain its position, you can apply friction to the rotation by using the Yoke Rotational Brake. On the Double Yoke version, there are two brakes and on the Single Yoke version (LCH), there is one brake. Turn the brake clockwise to increase the resistance on the Light Head Rotation. Only tighten enough to maintain position.

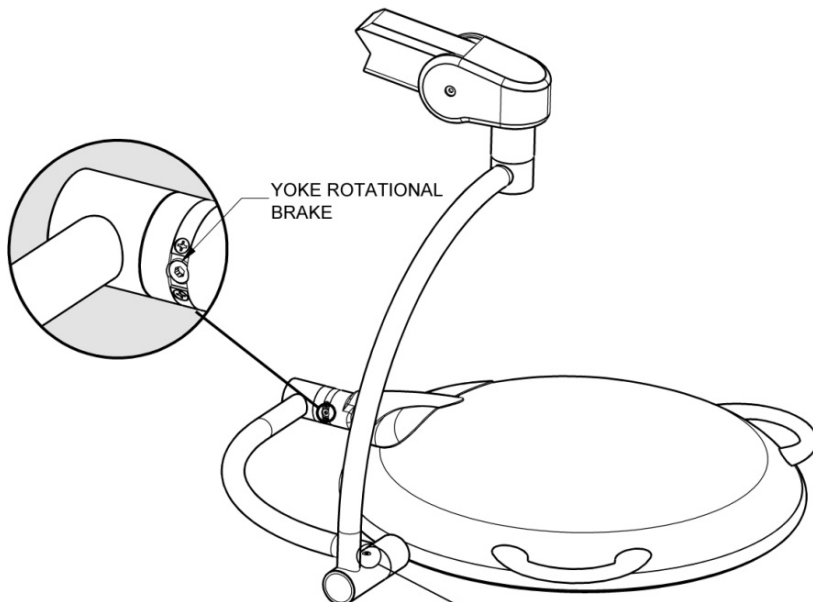

Figure 37: Yoke Rotational Brake - Double Yoke

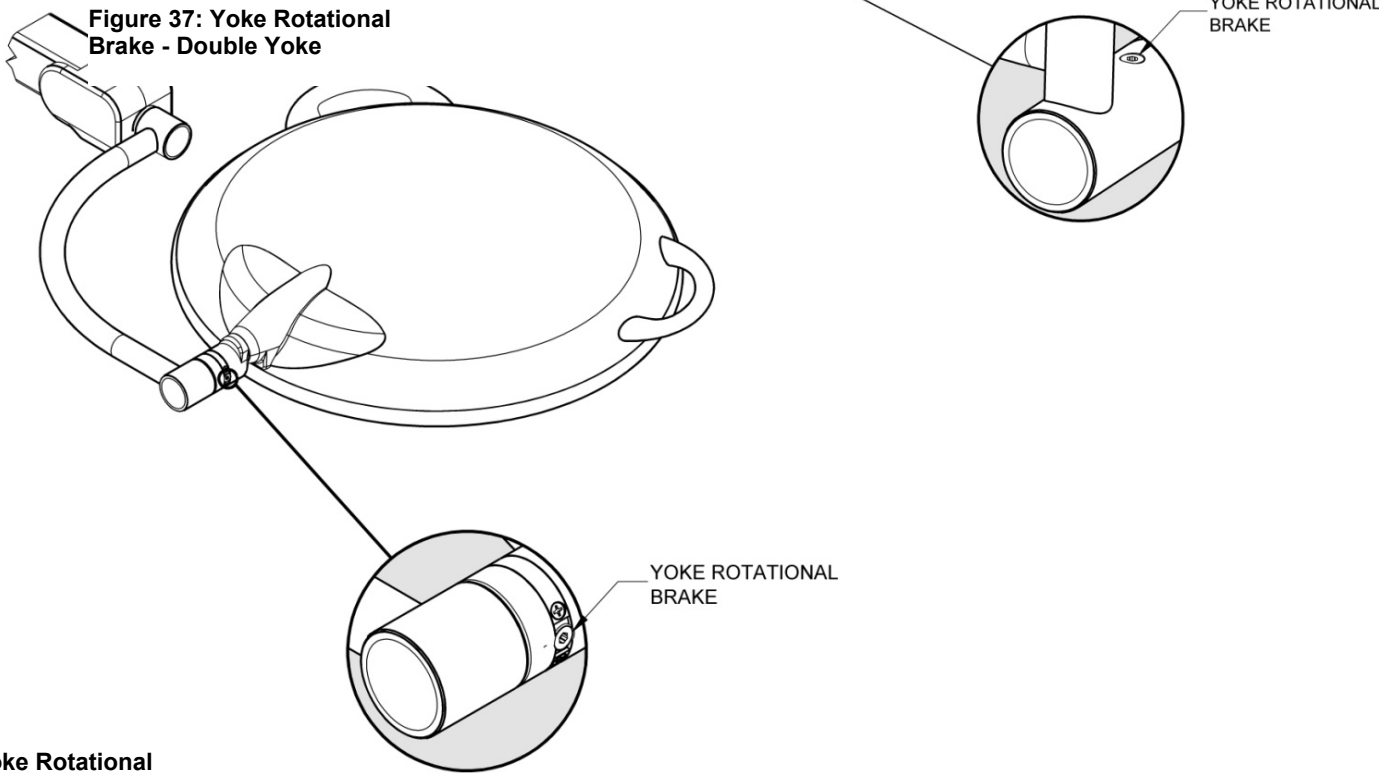

Figure 30: Yoke Rotational Brake - Single Yoke

Installation and Removal for the Sterilizable Handle Assembly (Camera Lights only)

Before the light can be used, the Sterilizable Handle Assembly must be installed.

The D2C comes equipped with an interchangeable Sterilizable Handle Assembly. The available interchangeable options are the Sterilizable Handle Assembly and a HD Camera Assembly.

To install the Sterilizable Handle Assembly it is first necessary to remove the plastic Sterilizable Handle, then turn the mounted light head so that the LED's face vertically towards the ceiling. Position the Handle Assembly so that the alignment pins align with the corresponding alignment holes in the light head. Using one hand to prevent the light head from moving gently push the Handle Assembly until it is firmly inserted into the light head. Then fasten the three captive screws and reattach the plastic Sterilizable Handle. The light head is now ready to use.

To remove the Sterilizable Handle Assembly, reverse the above sequence.

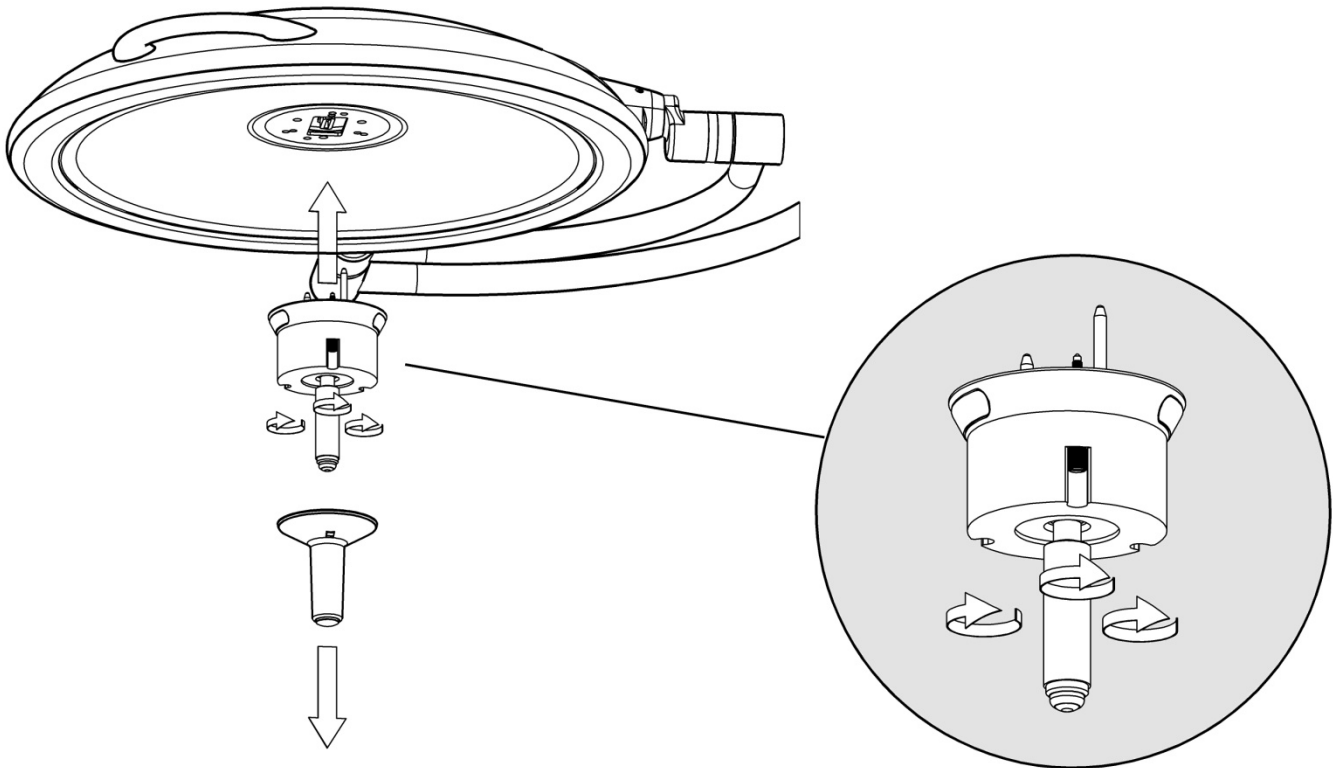

Figure 38: Attaching the Sterilizable Handle

Installation and Removal for the HD Camera Assembly (Camera Lights only)

To install the HD Camera Assembly it is first necessary to remove the Sterilizable Handle Assembly as listed above. Once the Sterilizable Handle Assembly has been removed and the light head has the LED's facing vertically towards the ceiling, remove the outer housing on the camera by pushing the retaining ball and sliding the outer housing off of the Camera Assembly. Then position the Camera Assembly so that the alignment pins align with the corresponding alignment holes in the light head. Using one hand to prevent the light head from moving gently push the Camera Assembly until it is firmly inserted into the light head. Then fasten the three captive screws and reinstall the camera outer housing (a click will be heard when the housing is locked in place). The light head now has HD Camera ready.

NOTE: The camera is a delicate instrument and must be handled with caution.

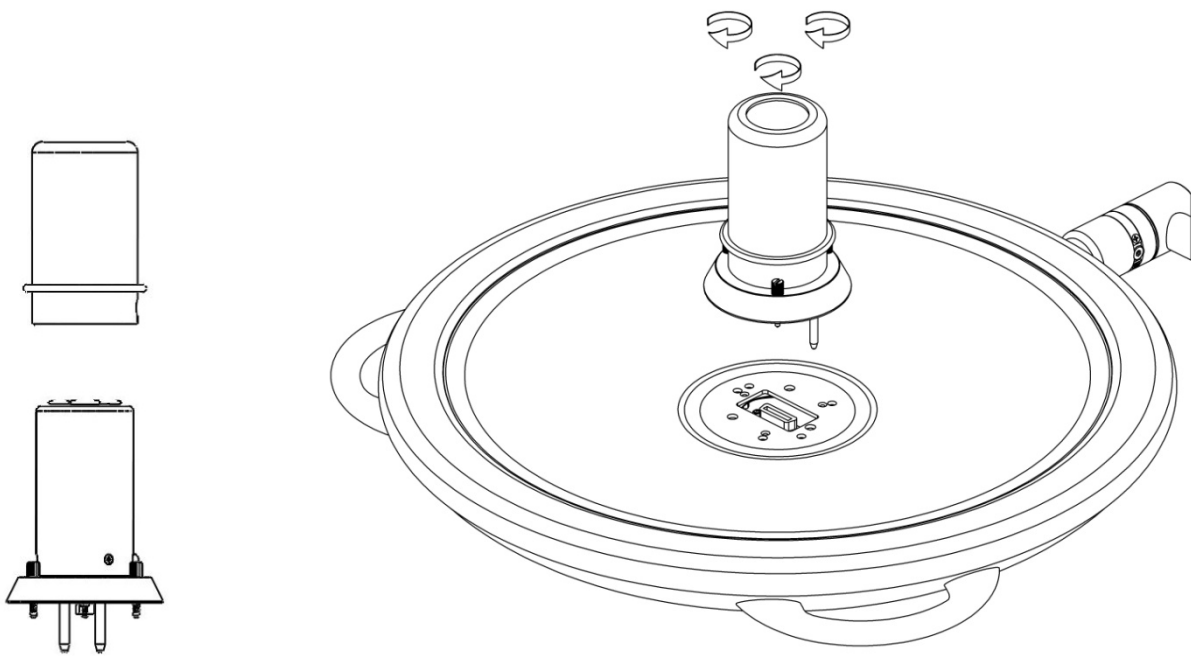



















Figure 39: Camera Assembly (D2C only)

Figure 40: Inserting Camera Assembly (D2C only)

Section 6: General Maintenance

General Safety

-  Electric shock hazard! The Arm System can carry an electric current and must be treated with the utmost care during cleaning and disinfection
-  Only facility authorized maintenance personnel should troubleshoot and/or repair the Lighting System. Troubleshooting by unauthorized personnel could result in personal injury and/or property damage.
-  No modification of this equipment is allowed. Do not modify this equipment without authorization of the manufacturer. If this equipment is modified, appropriate inspection and testing must be conducted to ensure continued safe use of the equipment.
-  Isolation from Supply Mains- The isolation shall be provided by the facility. Appropriate Breakers with simultaneous action to all poles shall be made available.
-  The articulating arm is spring loaded. When removing the head/yoke ensure that the arm lock pin has been installed. Failure to do so could result in personal injury and/or property damage.
-  The articulating arm is spring loaded. Never remove the arm lock pin until the head/yoke has been installed. Failure to do so could result in personal injury and/or property damage.
-  Follow the product manufacturer's instructions. Failure to do so could result in personal injury and/or property damage.
-  If the unit fails any part of the preventive maintenance functional checks, repair the unit before use on any patient. Failure to do so could result in personal injury and/or property damage.
-  Do not use harsh cleaners, solvents, or detergents. Failure to do so could result in equipment damage.
-  Do not use silicone based lubricants. Equipment damage could occur.
-  The front lens is supplied with a protective hard coat to resist scratching. Never use abrasive cleaners on the front lens. Failure to do so could result in equipment damage.
-  Turn off main power before any repairs are started. Failure to do so could result in personal injury and/or property damage.
-  Do not pinch any wires during installation. Pinched wires can cause an electrical shock hazard, resulting in personal injury and/or property damage.
-  Use only Medical Illumination fuses P/N 0001475 (250 VAC/1.6A slow-blow, Break Capacity: 150%, 1.6A @ 60 minutes min. 1000%, 1.6A @ 20ms min to 300ms max.) if replacement is necessary. Failure to do so could result in personal injury and/or property damage.
-  Do not expose the unit to excessive moisture. Failure to do so could result in personal injury and/or property damage.
-  Do not rest articles or liquids on top of the VistOR MS LED Surgical Lighting System. Spilled liquids will damage the light head and arm assemblies causing an electric shock hazard.
-  Use only a White Solid Lubricant Paste Grease (white grease) in lubricating securing segments.

Follow general safety precautions

***** Warning *****

Other than the Sterilizable Handle on the Light Head, the Arm System is not suitable for sterilization

Avoid damage

- Make sure that no liquid penetrates the appliance whilst cleaning it
- To prevent damage to plastic parts, refrain from using abrasives or alkaline, acidic or corrosive cleaning agents.
- Do not use bleaching agents on stainless steel parts.

Deploy trained technical specialists only and abide by national regulations.

- Cleaning/disinfection must be carried out by trained technical specialists only.

***** Caution *****

Health hazard

Disinfectants can contain substances hazardous to health which, when in contact with the skin and eyes, can cause injuries or affect the respiratory organs when inhaled. Observe the protective measures;

- Observe the hygiene regulations.
- Adhere to the disinfectant manufacturer's instructions.
- Perform surface disinfection every working day and in case of contamination.

Disinfection method

Wiping disinfection is the standardized disinfection method prescribed for the Light System. Hygiene regulations and related safety instructions for the disinfection methods to be applied must be defined by the operator.

- In case of contamination with potentially infectious material (e.g. blood, body secretion or excrement) the surfaces must be immediately and specifically disinfected.
- Make sure you apply the disinfectant in the correct concentration.
- For surface disinfection do not spray, but wipe, the surfaces.
- Wiped surfaces may only be used after the disinfectant has dried.

Handle Sterilization and Cleaning

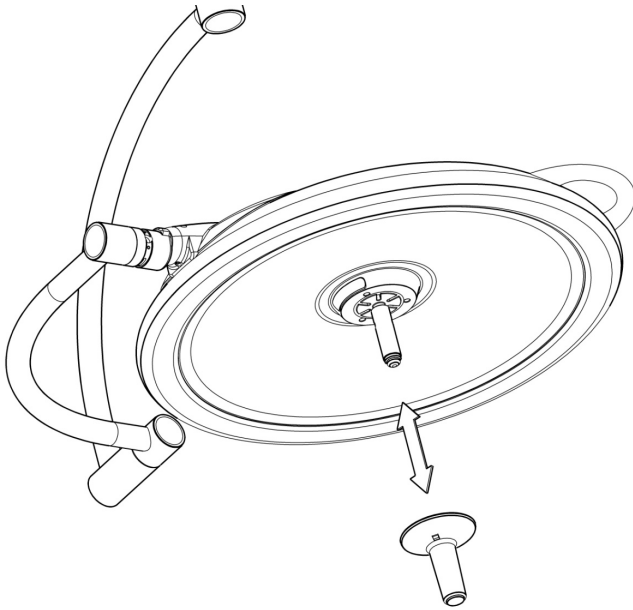

Figure 41: Handle Sterilization

The VistOR MS LED features a removable sterilizable Handle.

Handle Sterilization

- Remove the sterilizable handle by pressing the Handle Button near the base of the handle towards the center and pull the handle off the handle post.
- Sterilize the handle utilizing steam sterilization of minimum 250° Fahrenheit for a minimum of 30 minutes in compliance with AAMI-SSSa-1988 Good Hospital Practices, Steam Sterilization and Sterility Assurance, or equivalent method.

Cleaning

Follow the safety instructions on Page 56.

*** Warning ***

Risk of contamination and infection of the patient
Parts of the pendant system and the adaptations are made of plastic. Solvents can dissolve plastic materials. Strong acids, bases and agents with an alcoholic strength of more than 60% can lead to the plastic materials becoming brittle. Detached particles can fall into open wounds. If liquid cleaning agents are allowed to penetrate the pendant system and the adaptations, excess cleaning liquid may drip into open wounds.

Cleaning Agents

Recommended cleaning agents Use a mild soap solution or a regular dishwashing product.

1. Wipe the surfaces of the appliances with a moderately moist cloth; add a mild soap solution (dishwashing product) if required.
2. Afterwards, carefully wipe the surfaces dry with a clean cloth.

***** Warning *******Electric shock hazard**

Power supply cables are laid in the pendant system, the adaption and the end device. Contact with energized components presents a danger to life from electric shock. Disconnect the appliance from the mains before any maintenance work;

- Disconnect all the poles of the pendant system from the mains and prevent it from being switched back on again.
- Make sure that the Light Head or Monitor connected are de-energized.
- Wait until the Light Head or Monitor has cooled down.

***** Warning *******Carrying out maintenance work**

Maintenance work may only be carried out by qualified personnel who have been authorized and instructed by the operator.

Built-in components from third-party manufacturers

Built-in components from third-party manufacturers must be inspected and maintained as prescribed in the applicable Operating Instructions.

Repeated inspection

The repeated inspection must be performed in accordance with DIN EN 62353 standard.

Checking the securing segments on the Extension Arm

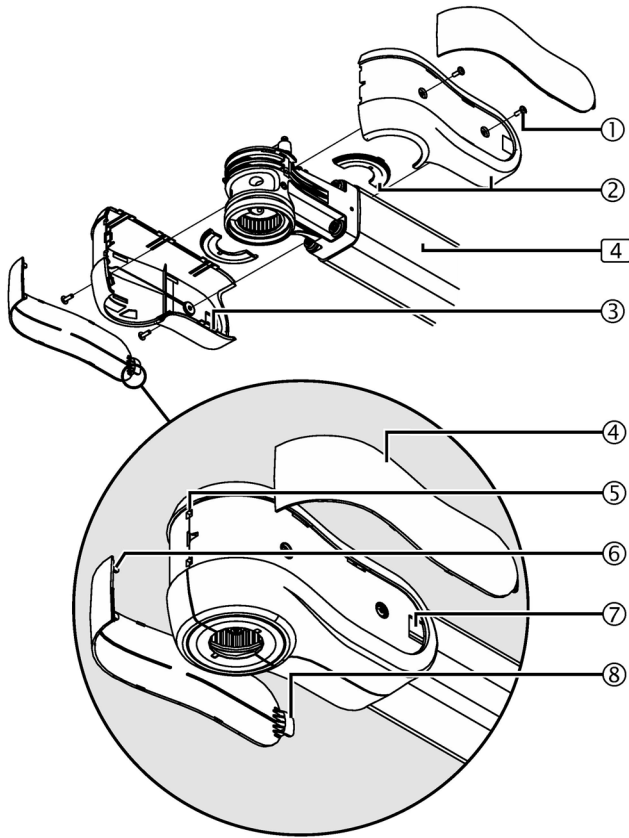

Figure 42: Dismantling the decorative caps and socket covers from the Extension Arm

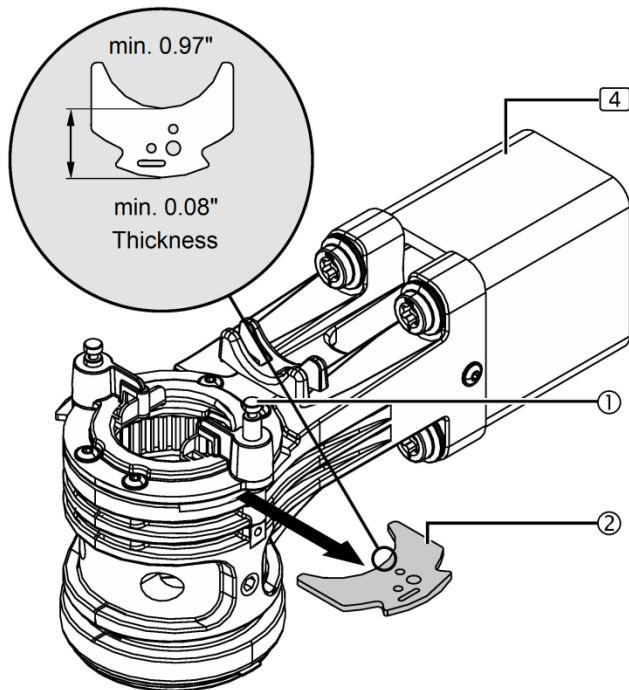

Figure 43: Dismantling the securing segment

The Figure shows a simplified illustration of the Extension Arm [4] without cables, Spring Arm, or Light Head.

The 2 securing segments for each Extension Arm [4] must be checked for minimum strength, lubricated with white grease and replaced if the minimum strength is not achieved.

Dismantling the decorative caps

1. Simultaneously push the 2 decorative caps (4) forwards in order to route the 2 straps (8) out of the cutouts (2).
2. Gently disengage the locking pins (6) on the decorative caps (4).
3. Gently route and remove the decorative caps (4) out of the 2 holes (5) on the socket covers (2).

Dismantling the socket covers

1. Unscrew 2 cross recessed head screws (1) from the right- and left-hand socket cover (2).
2. Gently disengage the locking pins (3) and remove the right- and left-hand socket cover with optional cover plates (2).

Dismantling the securing segments

The Figure shows a simplified illustration of the Extension Arm [4] without cables, Spring Arm, adaption and end device.

***** Warning *****

Risk of the Light Head dropping

The Spring Arm is kept in position by 2 securing segments. If both securing segments are dismantled simultaneously from the Extension Arm, there is a risk of the Spring Arm, Light Head or Monitor dropping out of the Extension Arm and causing severe injury;

- Dismantle the securing segments one after the other.

Dismantling the first securing segment

1. Push the latch pin (1) slightly upwards and remove the securing segment (2).
 2. Check whether the securing segment (2) achieves a minimum thickness of 0.08" (2.1mm) and a minimum length of 0.97" (24.5mm); otherwise, replace the securing segment.
- Use a caliper gauge for measurement.
 - Replace the securing segment (2) if the specified dimensions are not achieved.

Mounting the securing segments

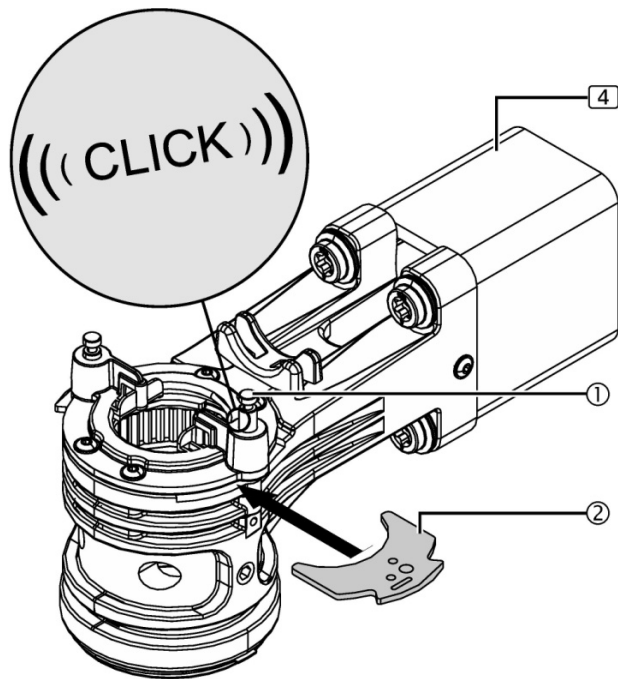

Figure 44: Mounting the securing segment

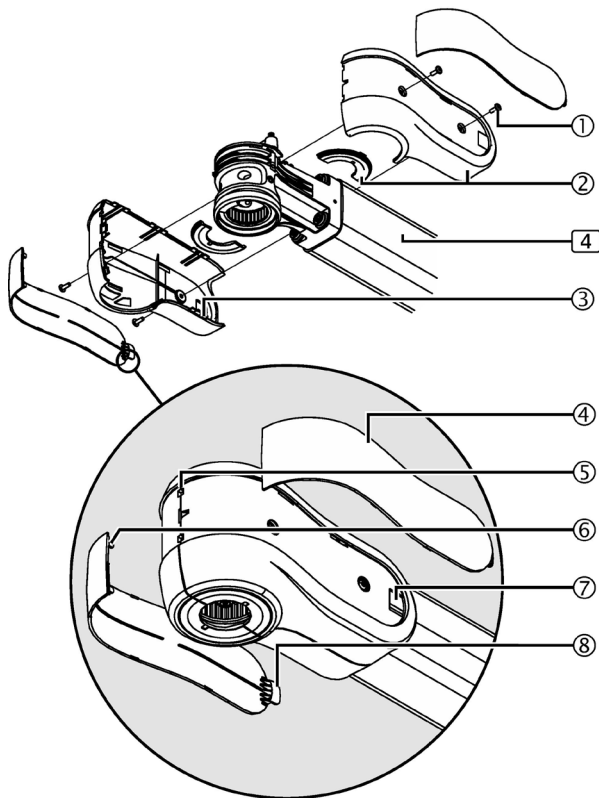

Figure 45: Mounting the socket covers and decorative caps to the Extension Arm

Figure shows a simplified illustration of the Extension Arm [4] without cables, Spring Arm and end device.

1. Lubricate the securing segment (2) with white grease.
2. Lubricate the Spring Arm pivot (not illustrated in the Figure) with white grease through the fitting aperture of the securing segment (2).
3. Route the securing segment (2) into the Extension Arm until it snaps into place.
 - The spring-actuated latch pin (1) audibly clicks into place.
4. Check securing segment (2) is securely in place;
 - The latch pin (1) must audibly click into place.
 - The latch pin (1) is at the same height as its opposite latch pin.
5. Dismantle and check the second securing segment.
 - The second securing segment is on the opposite side.
6. Re-mount the second securing segment

Mounting the socket covers and decorative caps to the Extension Arm

1. Screw the left-hand socket cover with optional cover plate (2) onto the Extension Arm [4] using 2 cross recessed head screws (1).
2. Place the right-hand cover panel with optional cover plate onto the left-hand socket cover (2) such that all the locking pins (3) engage with each other and screw it onto the Extension Arm [4] using 2 cross recessed head screws (1).
3. Check that the socket cover with optional cover plates (2) is securely in place;
 - The socket covers with optional cover plates (2) must tightly engage with each other without gaps and be tightened with 2 cross recessed head screws (1).

Mounting the decorative caps

***** Notice *****

Damage to the decorative caps

To prevent damage to the decorative caps;

- The mounting steps described below must be executed in the correct order:
1. Attach the locking mechanisms (6) of the decorative caps (4) into the 2 fittings (5) on the covers (2).
 2. Fold the decorative caps (4) towards the Extension Arm 4 and insert the straps (8) into the cutout (7) on the socket covers (2).
 3. Check that the decorative caps (4) are securely in place;
 - The decorative caps (4) must securely engage in the socket covers (2) without gaps.

Checking the securing segment on the Spring Arm - L21/MD21

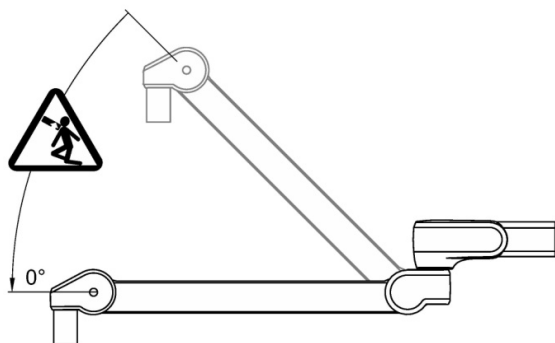
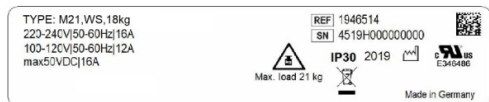
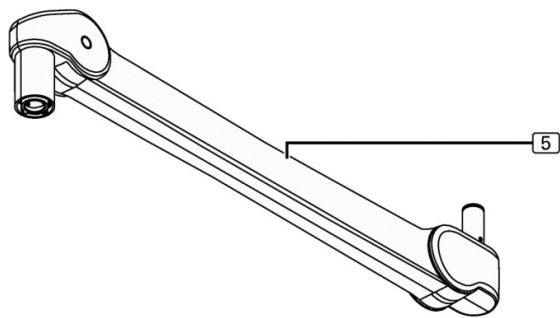
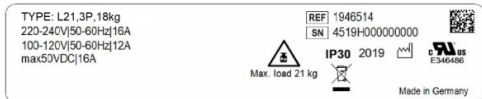
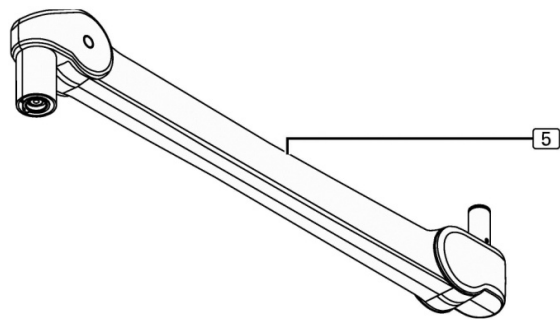

Figure 46: Adjusting the L17/MD21 Spring Arm

Checking the securing segment on the Spring Arm L21/MD21

The 2 securing segments for each Spring Arm 5 must be checked for minimum strength, lubricated with white grease and replaced if the minimum strength is not achieved.

Identify the version of the Spring Arm [5] mounted according to the information on the rating plate.

You can identify your Spring Arm L21 mounted by the TYPE designation: L21.

You can identify your Spring Arm MD21 mounted by the TYPE designation: MD21.

The rating plate is attached to the top side of the Spring Arm [5].

Adjusting the Spring Arm to the lowermost horizontal (0°) end stop position

Follow the safety instructions on Page 56.

***** Warning *****

***** Risk of Light Head dropping *****

The Light Head is kept in its position in the Spring Arm by 2 securing segments. If the 2 securing segments are dismantled simultaneously, there is a risk of the Light Head or Monitor sliding out of the Spring Arm. In this case the Spring Arm suddenly jumps up and can cause severe injury;

- Before checking the securing segments set the Spring Arm to its lowermost horizontal (0°) end stop position.
1. Set the Spring Arm [5] to its lowermost horizontal (0°) end stop position.
 - To do this, dismantle the cover panels from the Spring Arm and remount them after checking the securing segments.
 2. Check that the Spring Arm is safely locked in place;
 - Once the Spring Arm has been fixed in its lowermost horizontal position, it must no longer be possible to move the Spring Arm upwards

Dismantling and re-mounting the securing segment

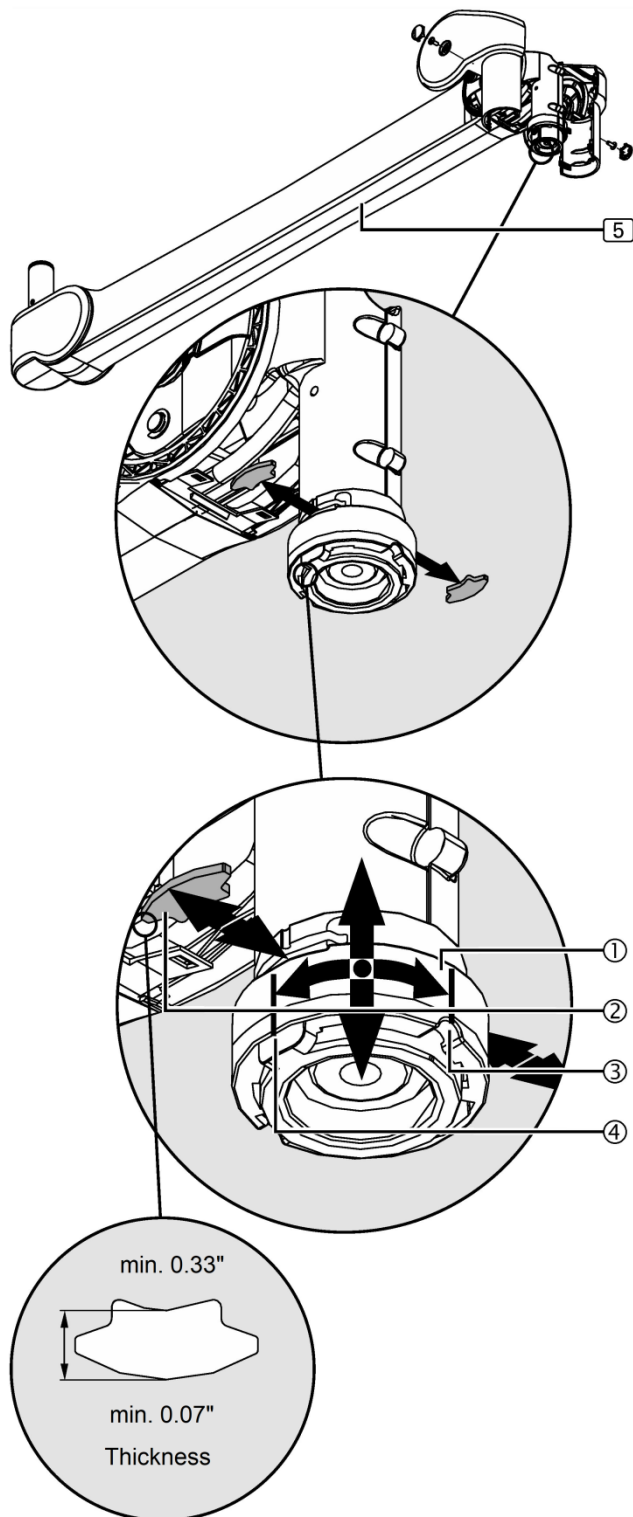

Figure 47: Checking the securing segment

The light head and monitor cradle are kept in its position in the Spring Arm by 2 securing segments. If both securing segments are dismantled simultaneously from the Spring Arm, there is a risk of the light head or monitor cradle dropping out of the Spring Arm and causing severe injury;

- Dismantle the securing segments one after the other.

Dismantling the first securing segment

1. Rotate the segment securing device ① approximately 90° to the right, route it slightly downwards and then remove the first securing segment ②.
- To do this, cover the second securing segment on the opposite side with your hand in order to prevent it from dropping out of the Spring Arm.
2. Route the segment securing device ① back upwards.
3. Check whether the securing segment ② achieves a minimum thickness of 0.07" (1.8mm) and a minimum length of 0.33" (8.3mm); otherwise, replace the securing segment.
- Use a caliper gauge for measurement.
- Replace the securing segment ② if the specified dimensions are not achieved.

Mounting the first securing segment

4. Lubricate the securing segment ② with white grease.
5. Route the segment securing device ① slightly downwards.
- To do this, cover the second securing segment on the opposite side with your hand in order to prevent it from dropping out of the Spring Arm.
6. Lubricate the pivot of the Light Head/Yoke Assembly or Monitor Cradle with white grease through the fitting aperture of the securing segment ②.
7. Place the securing segment ② and route the segment securing device ① towards the top and then rotate it approximately 90° to the left.
- The cutout ③ in the segment securing device ① must protrude over the optional brake screw or brake screw hole ④.
8. Check that the securing segment ② is securely in place;
- The Light Head or Monitor must rotate freely.

Checking the second securing segment

9. Dismantle and check the second securing segment.
10. Re-mount the second securing segment.

Adjusting the vertical lift and the optional brake

11. Adjust the vertical lift of the Spring Arm and the optional brake described previously.
- Mount the cover panels to the Spring Arm.

Securing segment on the Spring Arm - LCH17

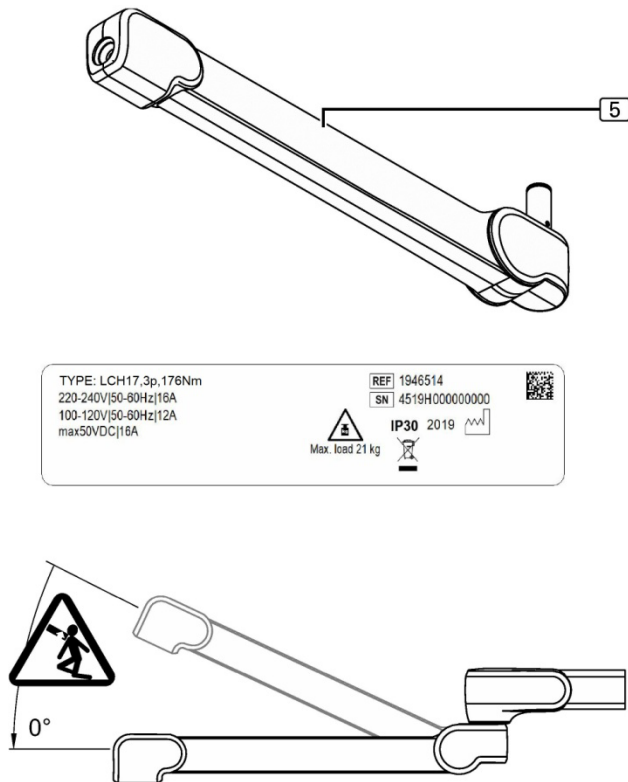

Figure 48: Adjusting the LCH17 Spring Arm

The 2 securing segments for each Spring Arm [5] must be checked for minimum strength, lubricated with white grease and replaced if the minimum strength is not achieved.

Identify the version of the Spring Arm [5] mounted according to the information on the rating plate.

You can identify your Spring Arm LCH17 mounted by the TYPE designation: LCH17.

The rating plate is attached to the top side of the Spring Arm [5].

Adjusting the Spring Arm to the lowermost horizontal (0°) end stop position

Follow the safety instructions on Page 56.

The Light Head/Yoke Assembly or Monitor Cradle is kept in its position in the Spring Arm by 1 securing segment. If the securing segment is dismantled, there is a risk of the Light Head or Monitor sliding out of the Spring Arm. In this case the Spring Arm suddenly jumps up and can cause severe injury;

- Before checking the securing segments set the Spring Arm to its lowermost horizontal (0°) end stop position.
1. Set the Spring Arm [5] to its lowermost horizontal (0°) end stop position.
 - To do this, dismantle the cover panels from the Spring Arm and remount them after checking the securing segments.
 2. Check that the Spring Arm is safely locked in place. Once the Spring Arm has been fixed in its lowermost horizontal position, it must no longer be possible to move the Spring Arm upwards.

Dismantling and re-mounting the securing segment Spring Arm - LCH17

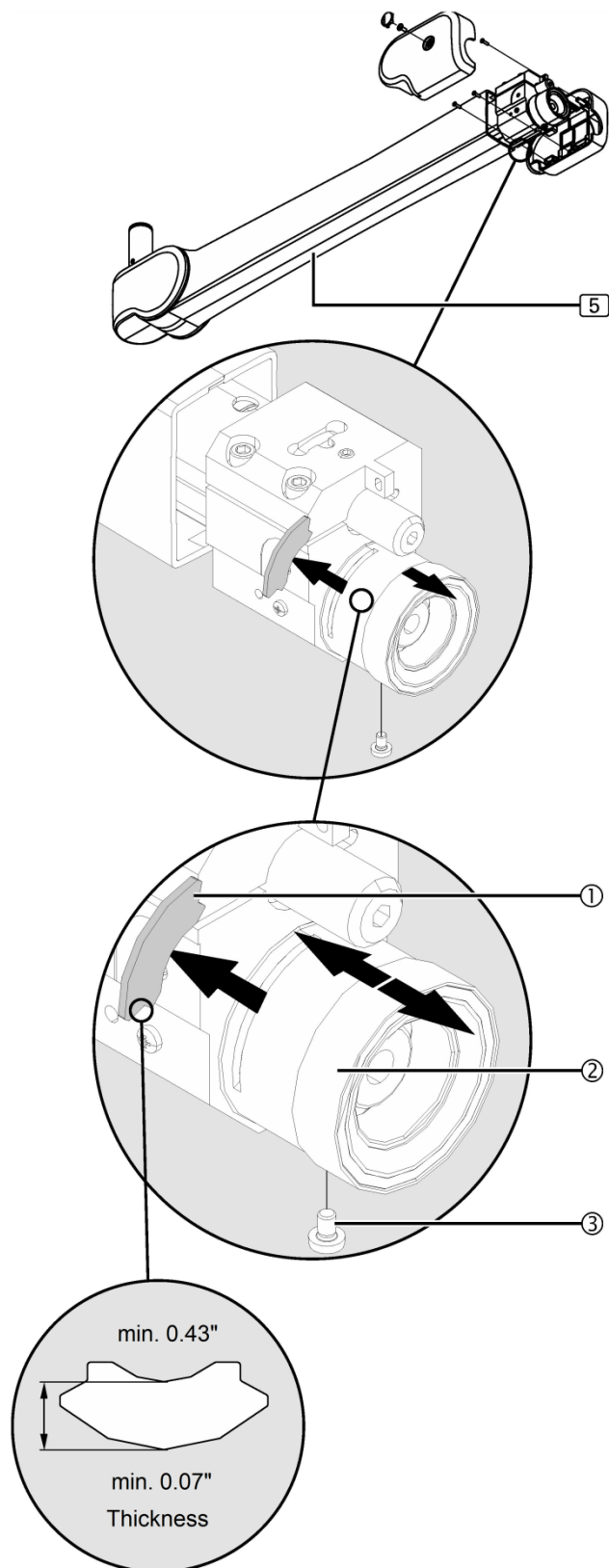

Figure 49: Checking the securing segment

The Figure shows a simplified illustration of the Spring Arm [5] without light head.

The Light Head is kept in its position in the Spring Arm by 1 securing segment. If the securing segment is dismantled, there is a risk of the Light Head sliding out of the Spring Arm, dropping and causing severe injury;

- To dismantle the securing segment, route the Yoke Pivot or Monitor Cradle out of the Spring Arm.

Moving the segment securing device

1. Unscrew the Phillips recessed head screw (3).
2. Push the segment securing device (2) forwards until the securing segment (1) is accessible.
3. Slightly unscrew the optional brake screw

Dismantling the securing segment

4. While securely holding the Light Head, remove the securing segment (1) and route the Yoke Pivot out of the Spring Arm. [5].
5. Check whether the securing segment (1) achieves a minimum thickness of 0.07" (1.8mm) and a minimum length of 0.43" (10.9mm); otherwise, replace the securing segment.
 - Use a caliper gauge for measurement.
 - Replace the securing segment (1) if the specified dimensions are not achieved.

Mounting the securing segment

6. Lubricate the securing segment (1) with white grease.
7. Lubricate the pivot of the Yoke Pivot with white grease.
8. Insert the Yoke Pivot into the Spring Arm and then insert the securing segment (1).
9. Check that the securing segment (1) is securely in place;
 - The Light Head/Yoke Assembly must rotate freely.
10. Re-tighten the optional brake screw.
11. Push the segment securing device (2) backwards and screw it on using 1 Phillips recessed head screw (3).

Adjusting the vertical lift and the optional brake

12. Adjust the vertical lift of the Spring Arm and the optional brake.
 - Mount the cover panels to the Spring Arm.

Checking the fixing screws on the Spring Arm - LCH17

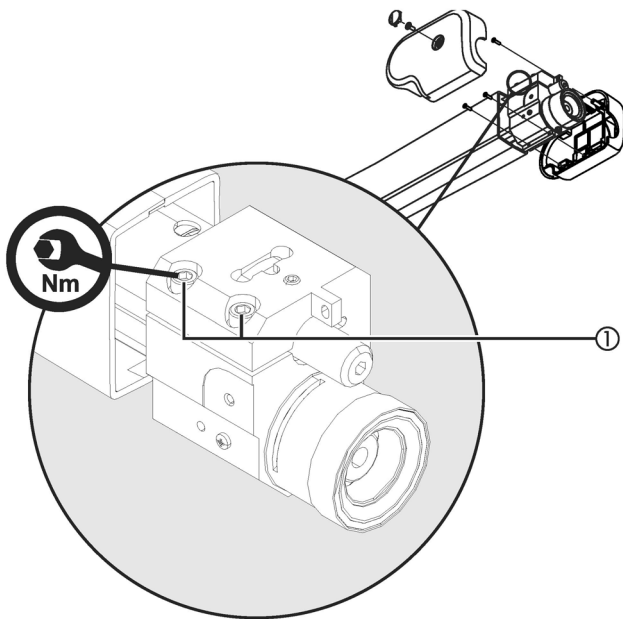

Figure 50: Checking the fixing screws on the Spring Arm LCH17

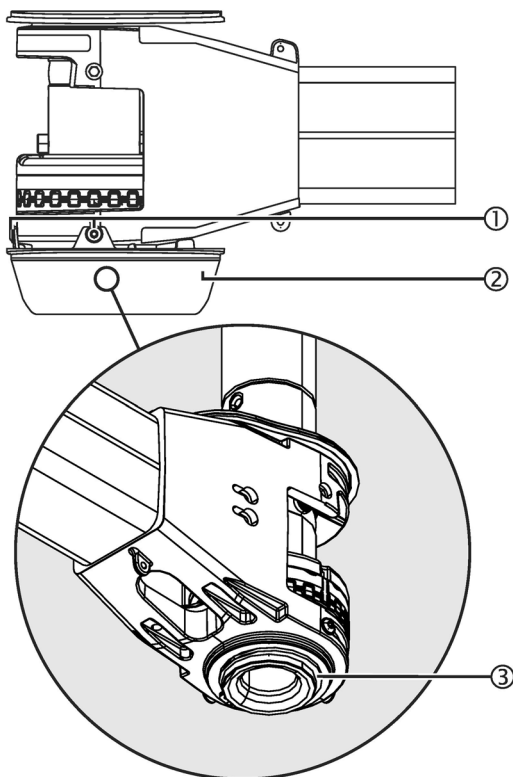

Figure 51: Checking the securing ring on the bottom Extension Arm towards the spindle

The Figure shows a simplified illustration of the Spring Arm without light head.

1. Dismantle the cover panels from the Spring Arm LCH17/LCH19.
2. Check if the 2 Allen cylinder screws ① actually exist on the front part and tighten them to $10\text{Nm} \pm 0.5\text{Nm}$.

- Use an Allen key (size 5).

3. Mount the cover panels to the Spring Arm LCH17.

Checking the securing ring on the bottom Extension Arm towards the spindle

The Figure shows a simplified illustration of the Extension Arm without cables.

Dismantling the side panels from the Extension Arm

1. Dismantle the cover panels from the Extension Arm.

Dismantling the bottom cover panel

2. Unscrew the 3 cross recessed head screws ① staggered 90° from the lower Extension Arm cover panel by approximately 2 revolutions.

- Use a Torx T10 screwdriver.

3. Gently remove the bottom Extension Arm cover panel ② from the Extension Arm towards the bottom.

Checking the securing ring

4. Check the securing ring ③ on the bottom Extension Arm towards the spindle;

- The securing ring ③ must be undamaged and sealed.

Mounting the bottom cover panel

5. To re-mount the Extension Arm cover panel ②, proceed in reverse order.

6. Tighten the 3 cross recessed head screws ① only manually.

- Use a Torx T10 screwdriver.

Mounting the side panels to the Extension Arm

7. Mount the cover panels to the Extension Arm.

Lubricating the brake screws

Lubricating the brake screws for the Extension Arm

1. Dismantle the cover panels from the Extension Arm.
2. Unscrew 2 brake screws. Lubricate the 2 brake screws with white grease and screw them back in place.
3. Mount the cover panels to the Extension Arm.

Lubricating the brake screws for the Spring Arm

1. Dismantle the cover panels from the Extension Arm..
2. Unscrew 2 brake screws. Lubricate the 2 brake screws with white grease and screw them back in place.
3. Adjust the 2 brake screws.
4. Mount the cover panels to the Extension Arm.

Lubricating the optional brake screw on the Spring Arm L21/MD21

1. Dismantle the cover panels from the Spring Arm L21/MD21.
2. Unscrew the brake screw. Lubricate it with white grease and screw it back in place.
3. Adjust the brake screw.
4. Mount the cover panels to the Spring Arm L21/MD21.

Lubricating the optional brake screw on the Spring Arm LCH17/LCH19

1. Dismantle the cover panels from the Spring Arm LCH17/LCH19.
2. Unscrew the brake screw. Lubricate it with white grease and screw it back in place.
3. Adjust the brake screw
4. Mount the cover panels to the Spring Arm LCH17/LCH19.



Installation & Service Checklist

Project Information New Install Service

Technician Name:	Company Name:	Date:
Customer:	Model Number(s):	Serial Number(s):
Site Address:	City/State	Zip:
Job Completed? Yes <input type="checkbox"/> No <input type="checkbox"/>	Date of Completion:	

General Inspection	YES	NO	N/A	NOTES
Packaging: Package received in good condition. Easy to unpack without damaging device. Check packing list, are all items included. Installation & Instructions for Use easy to follow.	<input type="checkbox"/>	<input type="checkbox"/>	<input type="checkbox"/>	
Facility Mounting Structure & Installation: Facility Structure prepared properly ahead of time of installation. Mounted successful & square. Is there any rotational drift. All fasteners secured. Ceiling Cover installed.	<input type="checkbox"/>	<input type="checkbox"/>	<input type="checkbox"/>	
Are all decals legible? Model specific decals should be present on all systems. The decal should match the information on the model number / serial number label.	<input type="checkbox"/>	<input type="checkbox"/>	<input type="checkbox"/>	
Is the model number / serial number label legible? The model number / serial number label should be present on all systems. The label information should match the decal.	<input type="checkbox"/>	<input type="checkbox"/>	<input type="checkbox"/>	
Does the sterilizable handle function properly? The sterilizable handle should easily remove and be installed onto the light head handle.	<input type="checkbox"/>	<input type="checkbox"/>	<input type="checkbox"/>	
Can the lighting system move freely about all articulations? Referencing the manual, the lighting system should be able to move easily about all the rotation points. The degree of rotation is noted in the manual.	<input type="checkbox"/>	<input type="checkbox"/>	<input type="checkbox"/>	
Does the light head hold position? The light head should set in any position placed. No drifting should occur.	<input type="checkbox"/>	<input type="checkbox"/>	<input type="checkbox"/>	



General Inspection	YES	NO	N/A	NOTES
<p>Does the handle pushbutton function properly? Pressing the pushbutton at the end of the handle should turn the light on. Additional button presses will cycle through the available light intensities. Pressing and holding the button for 3 seconds will turn the light off or to ENDO mode if available. Once in ENDO mode, an additional button press will turn the light off.</p>	<input type="checkbox"/>	<input type="checkbox"/>	<input type="checkbox"/>	
<p>Does the indicator decal function properly? All LEDs on the indicator decal should light up and turn off to represent the current intensity level.</p>	<input type="checkbox"/>	<input type="checkbox"/>	<input type="checkbox"/>	
<p>Bluetooth tablet operational? When applicable, was the wireless tablet successful connected and fully operational (Light head On/Off, Intensity changes, and camera operation)</p>	<input type="checkbox"/>	<input type="checkbox"/>	<input type="checkbox"/>	
<p>Post Installation: Define service/maintenance schedule</p> <p>Maintain & store for future use: Adjustment Tools provided & Installation & Instructions for Use</p>	<input type="checkbox"/>	<input type="checkbox"/>	<input type="checkbox"/>	