

Section 3: Pre-Installation Guidelines

SPECIAL NOTE: Installation and repair of this equipment should be performed by a qualified mechanical contractor only. Medical Illumination does not warranty any damage occurring as a result of improper installation.

It is recommended that this installation manual be completely reviewed prior to installation.

Before installation, check to ensure the following minimum conditions are provided:

- The structural ceiling mount is designed to support a vertical load of 300 lbs (triple) and an off-center moment of 960 ft-lbs, the single light is significantly less. The structural mount should meet all local building codes.



A structural mount that does not meet these minimum conditions can cause serious injury and/or property damage.



Failure to use the correct mounting hardware can cause the arm/head assembly to become unstable, causing serious injury and/or property damage. If the ceiling mounting surface is not level, shim the ceiling casting to level the assembly.



Failure to level the ceiling plate may cause unwanted arm “drifting” during use.

- It is recommended that the Power Box be mounted directly over a 4-0 junction box. If this is not possible the input power supply lines should be wired in accordance with all applicable building codes.
- The supply circuit line must be as follows:
120 VAC lights- 110-120 VAC 50/60 Hz, single phase, three wire, capable of supplying 700 watts @ 6.4 amperes.
230 VAC lights- 220-240 VAC, 50/60 Hz, single phase, three wire, capable of supplying 700 watts @ 3.2 amperes.
- The power supply circuit must be in compliance with all applicable building codes.
- It is recommended that the Lighting System is connected to its own supply circuit with integral circuit breaker. The circuit breaker will act as the supply main disconnect switch.
- The MAINS ground wire, which is green and has a ring-type terminal at the end, should be securely fastened to the mounting plate with a screw and lock washer.



Failure to provide a circuit meeting these minimum standards or complying with local building codes can cause a shock hazard.

- Check the length of the ceiling rod supplied to make sure that it is the proper length to install and operate the light without interference or over reach. See the Ceiling Rod Calculations.

Mounting Plate preparation with an Interface Plate

If you choose to an Interface Plate in mounting your Light System, you should only use 5/8-11, A325 High Strength Threaded Rods, Hex Nuts and Washers. The following will illustrate the recommended hardware complement.

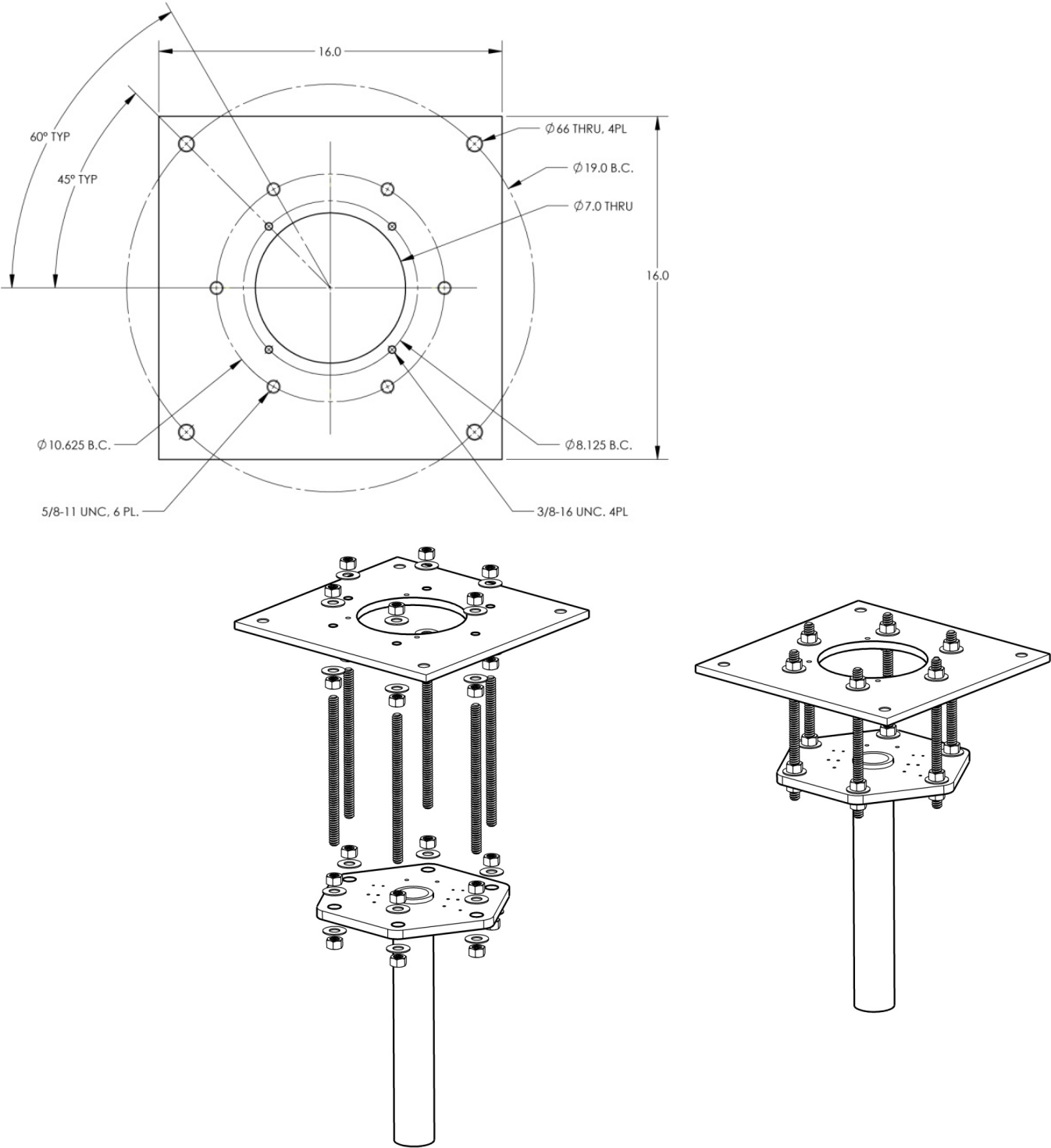

Figure 1: Ceiling Plate preparation with an Interface Plate

Ceiling Structure Construction and Mounting

The Ceiling Mount system will experience various levels of dynamic off center moment during regular use. Therefore, it is crucial that the ceiling structure be strong enough to uphold the weight of the system and support the positioning arms and light head without deflection. The owner and/or owner's contractor has the final responsibility for the strength and rigidity of the ceiling structure. An inadequate ceiling structure may result in serious injury, unintended drift, and/or equipment damage. **Because the ceiling structure is the owner's responsibility, the design and construction recommendation shown below covers only one of the many possible alternatives that can be used.** Medical Illumination highly recommends that the owner consult a structural engineer prior to designing and installing the ceiling structure.

Recommended Ceiling Structure Construction Details

The illustrations below are suggested mounting schemes per 2001 California Building Code – Section 1632A: Anchorage and Seismic. For any other mounting scheme, please consult a structural engineer and/or professional contractor for the best solution for your situation. Installation and repair of this equipment should be performed by qualified persons only. Medical Illumination does not warranty any damage occurring as a result of improper installation.

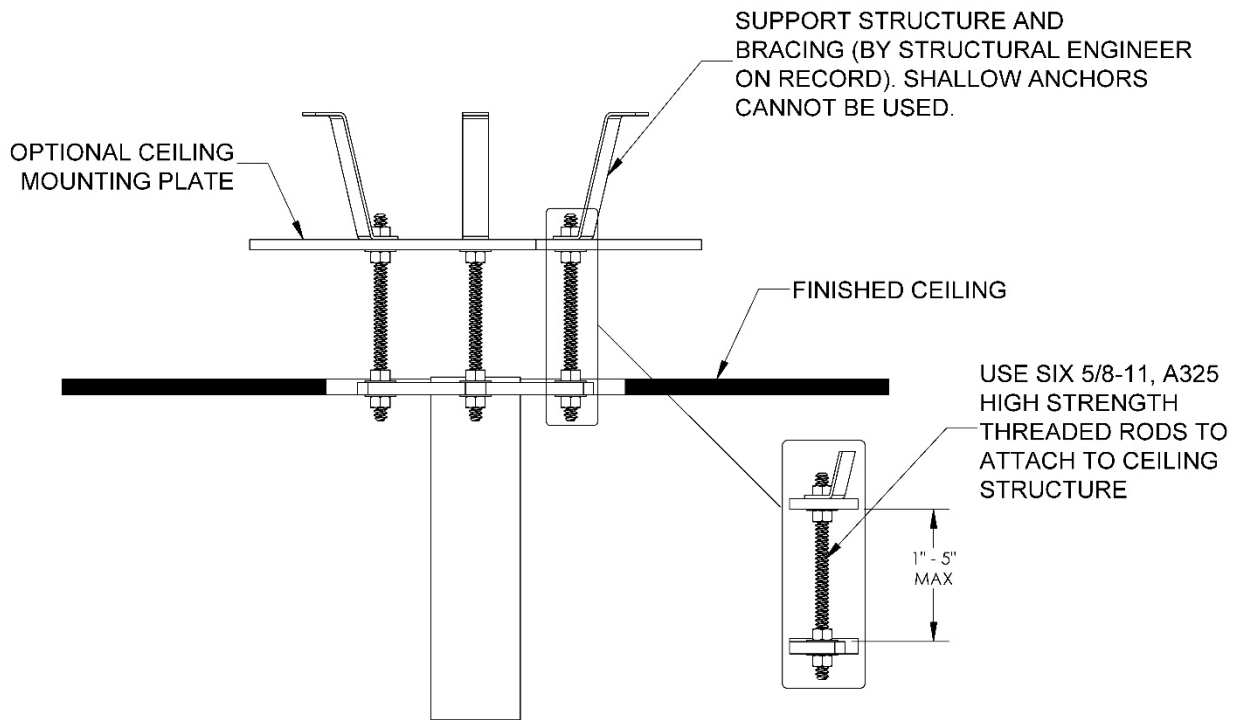
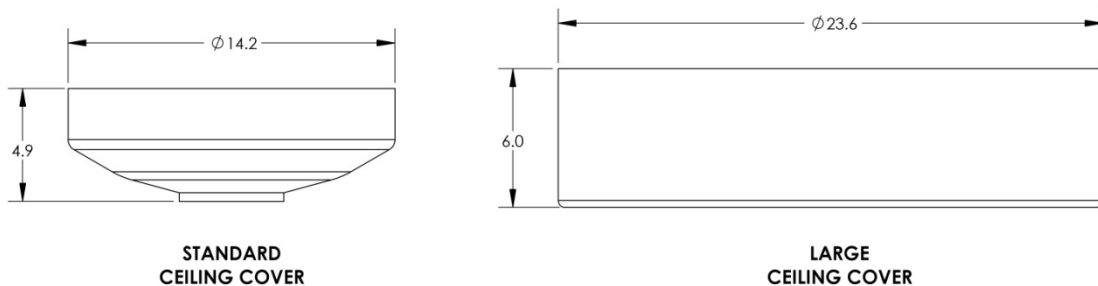

Figure 2: Recommended Ceiling Structure Construction

Ceiling Cover

The Standard Ceiling Cover is included with the system and can be used in most installations. If the finished ceiling level is above the mounting plate, or there is a larger ceiling opening, a larger Ceiling Cover is available.



Power Box

The VistOR MS LED Power Box supplies the power necessary to illuminate the VistOR MS LED surgical light systems. Remove the four screws on the top cover and lift cover off to make connections or change a fuse.

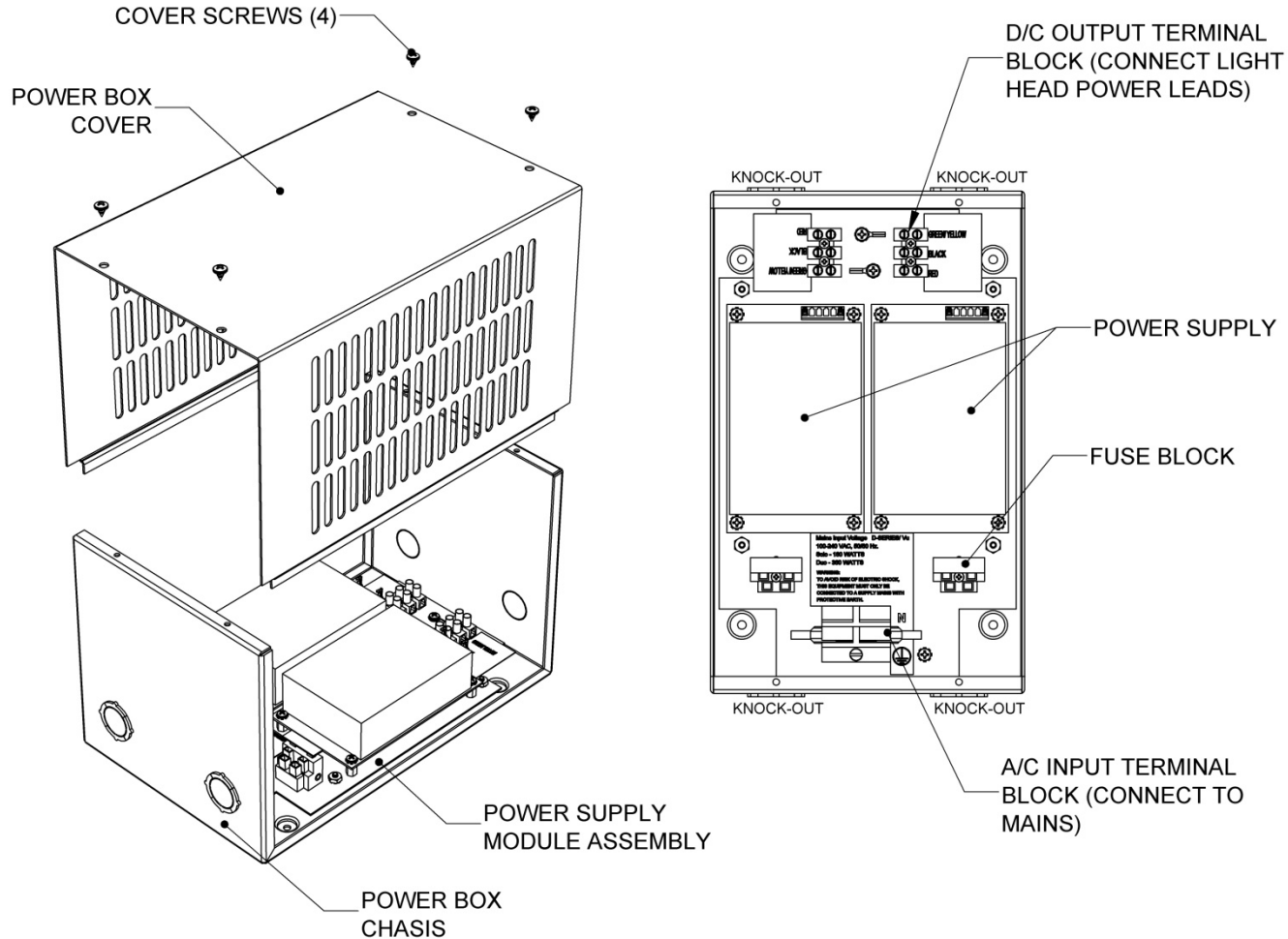

NOTE: INTERNAL WIRING NOT SHOWN FOR CLARITY

DUAL POWER SUPPLY SHOWN

Figure 3: The Power Box

Ceiling Rod Calculation, Single Mount

Use the following table to select the correct length ceiling rod for your application

Ceiling Mounting Height "Y"-Value	Ceiling Rod Length	"X"-Value	Head Room to Bottom of Extension Arm "Y"-Value - X-Value
9'0"/108"	8"	19"	89"
9'6"/114"	16"	27"	87"
10'0"/120"	24"	35"	85"
10'6"/126"	32"	43"	83"
11'0"/132"	39"	50"	82"
12'0"/144"	47"	58"	86"

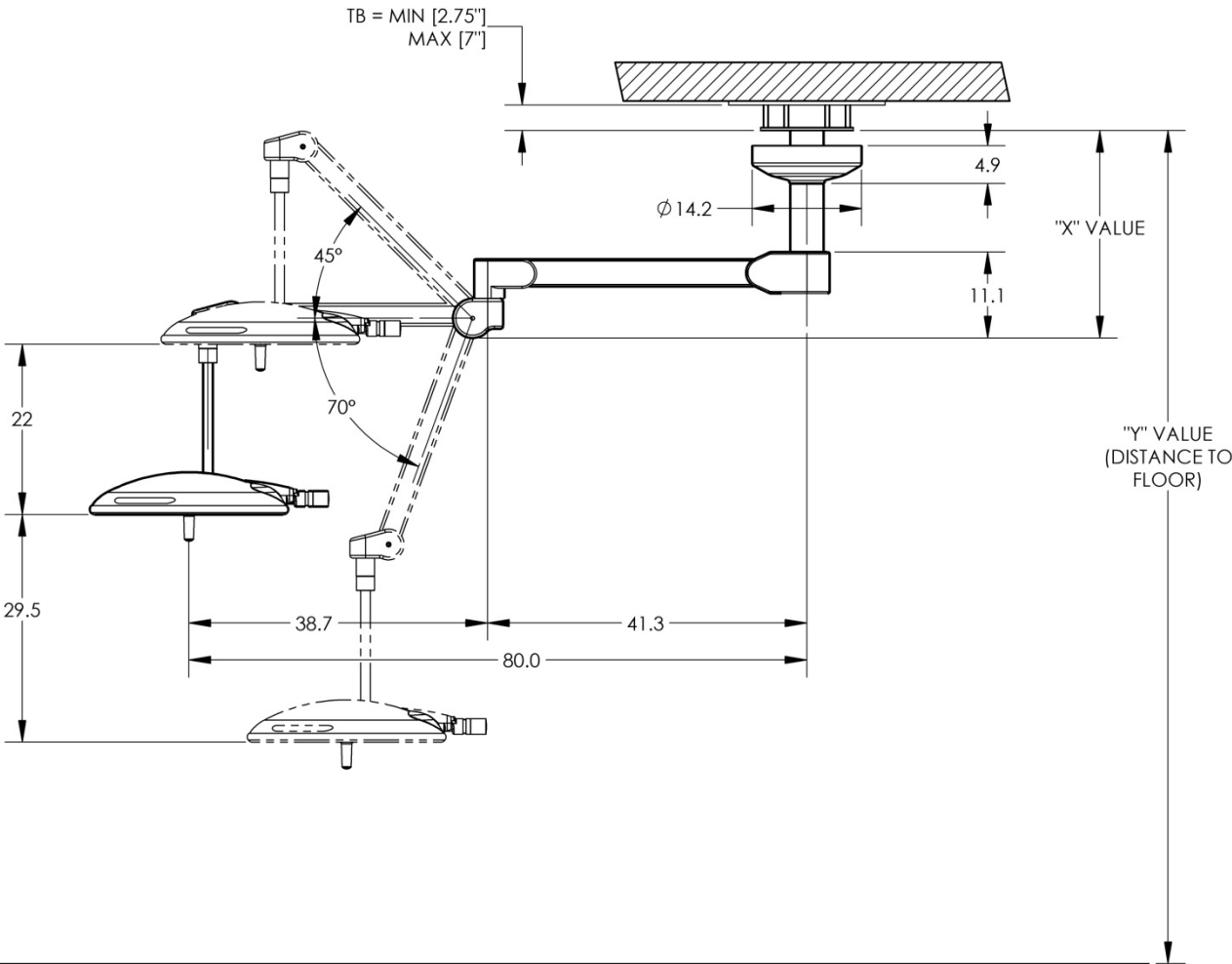

Ceiling Rod Calculation, Dual Mount

Use the following table to select the correct length ceiling rod for your application

Ceiling Mounting Height "Y"-Value	Ceiling Rod Length	"X"-Value	Head Room to Bottom of Extension Arm "Y"-Value - X-Value
9'0"/108"	N/A	N/A	N/A
9'6"/114"	16"	32"	82"
10'0"/120"	16"	32"	88"
10'6"/126"	24"	40"	86"
11'0"/132"	32"	48"	84"
12'0"/144"	39"	56"	88"
12'0"/144"	47"	64"	80"

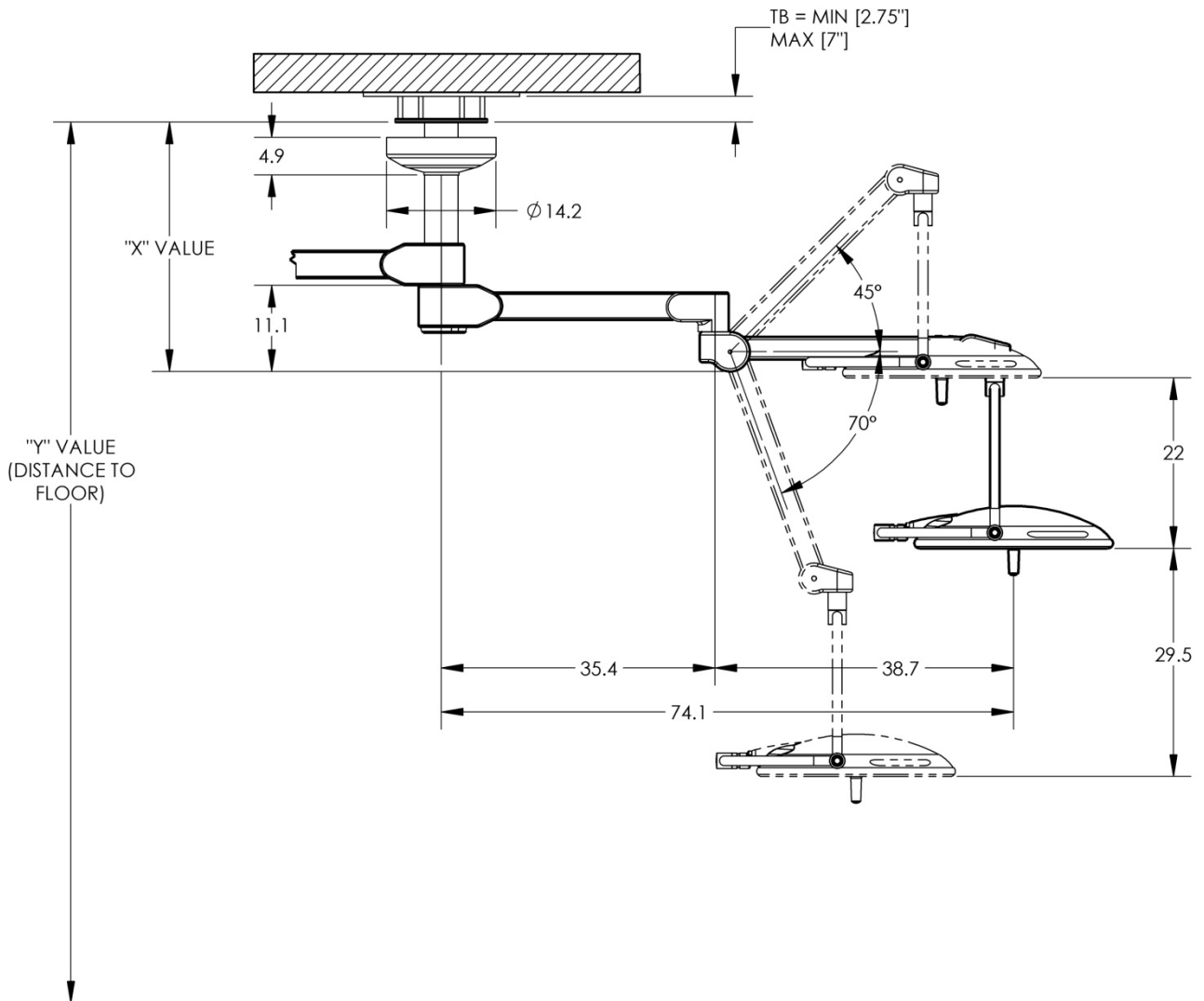

Ceiling Rod Calculation, Triple Mount

Use the following table to select the correct length ceiling rod for your application

Ceiling Mounting Height "Y"-Value	Ceiling Rod Length	"X"-Value	Head Room to Bottom of Extension Arm "Y"-Value – X-Value
9'0"/108"	N/A	N/A	N/A
9'6"/114"	N/A	N/A	N/A
10'0"/120"	16"	41"	79"
10'6"/126"	24"	49"	77"
11'0"/132"	24"	49"	83"
12'0"/144"	32"	69"	75"

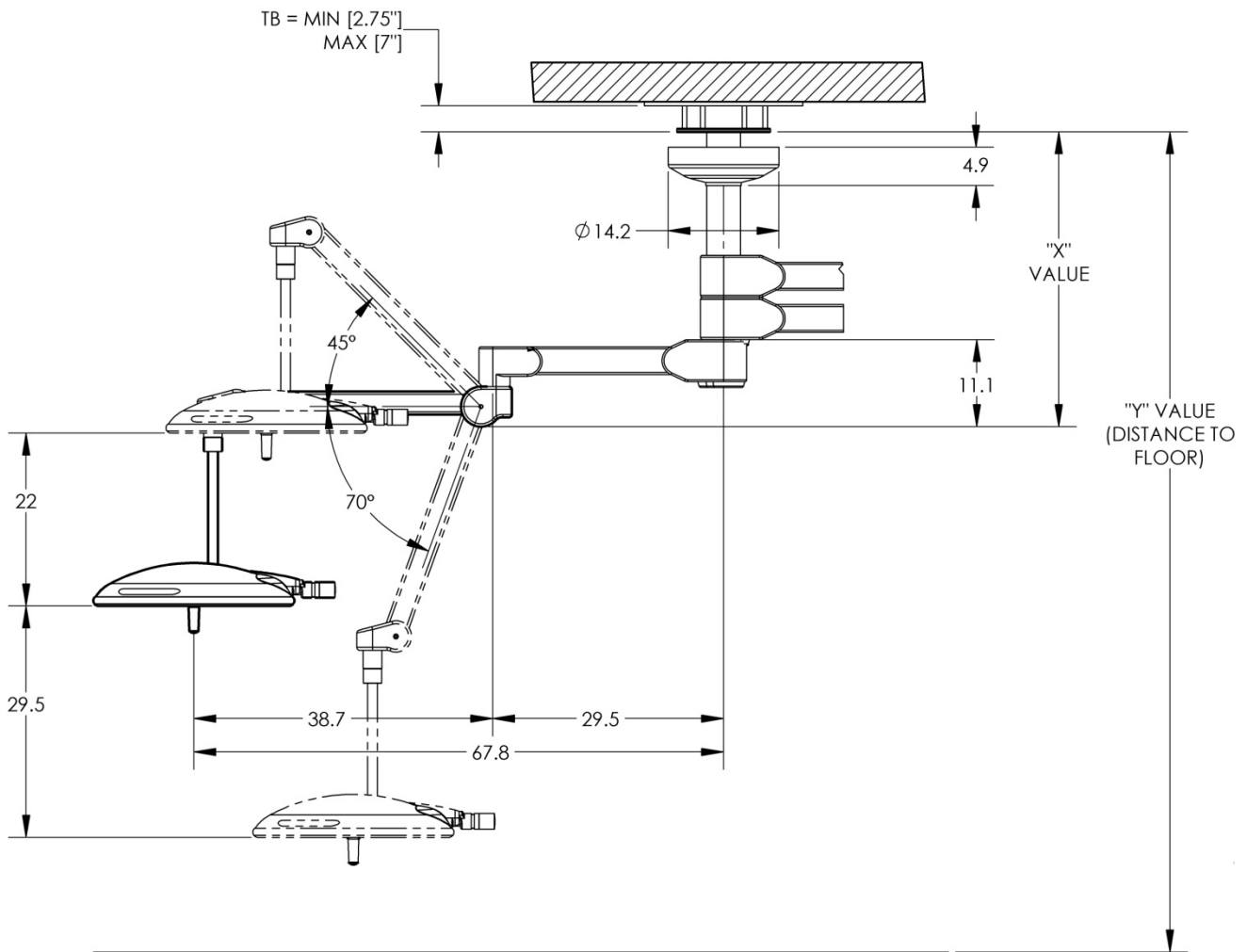

Ceiling Rod Calculation, Single LCH Mount

Use the following table to select the correct length ceiling rod for your application

Ceiling Mounting Height "Y"-Value	Ceiling Rod Length	"X"-Value	Head Room to Bottom of Extension Arm "Y"-Value - X-Value
9'0"/108"	8"	19"	89"
9'6"/114"	16"	27"	87"
10'0"/120"	24"	35"	85"
10'6"/126"	32"	43"	83"

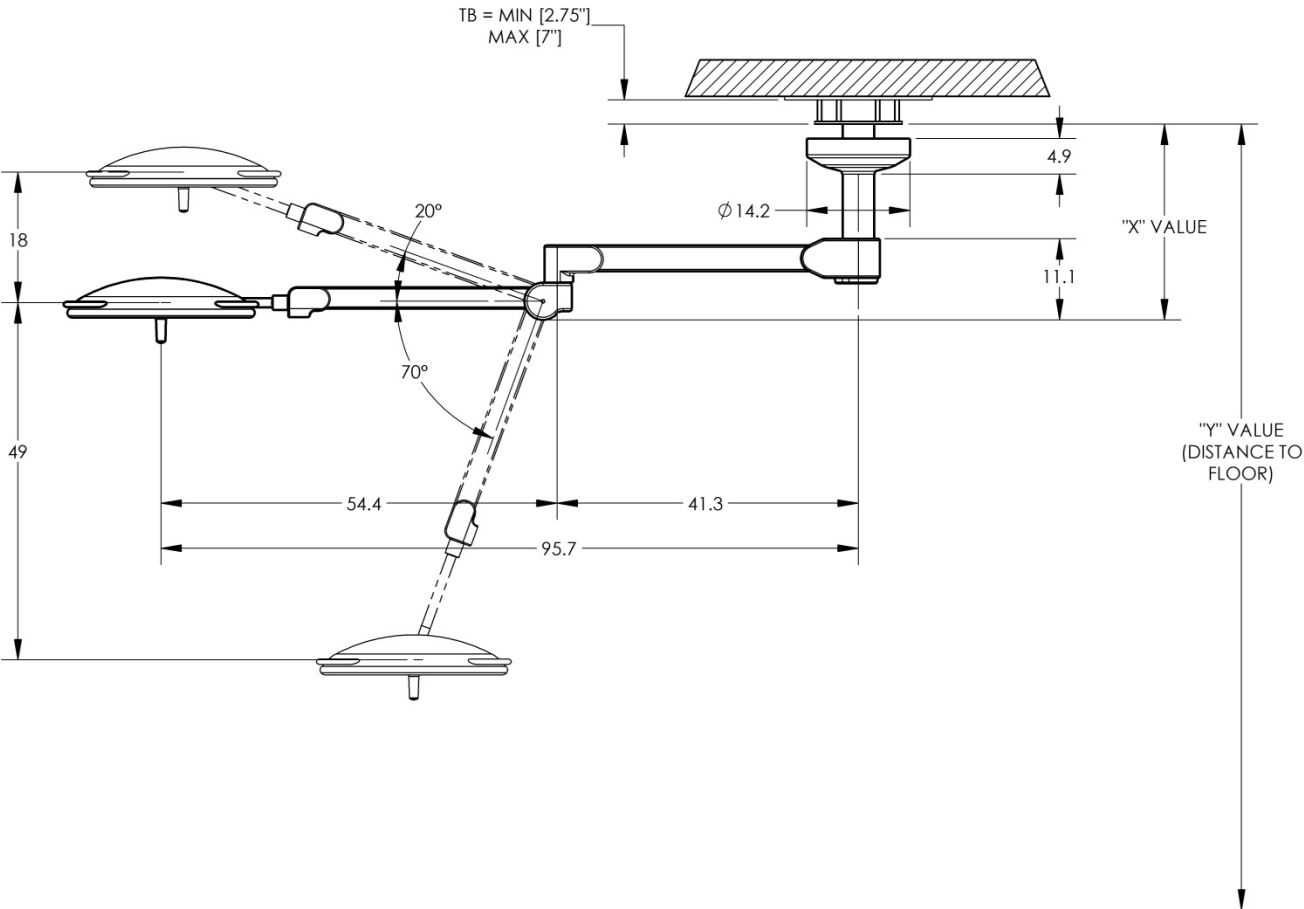

Ceiling Rod Calculation, Dual LCH Mount

Use the following table to select the correct length ceiling rod for your application

Ceiling Mounting Height "Y"-Value	Ceiling Rod Length	"X"-Value	Head Room to Bottom of Extension Arm "Y"-Value - X-Value
9'0"/108"	8"	24"	84"
9'6"/114"	16"	32"	82"
10'0"/120"	24"	40"	80"
10'6"/126"	32"	48"	78"

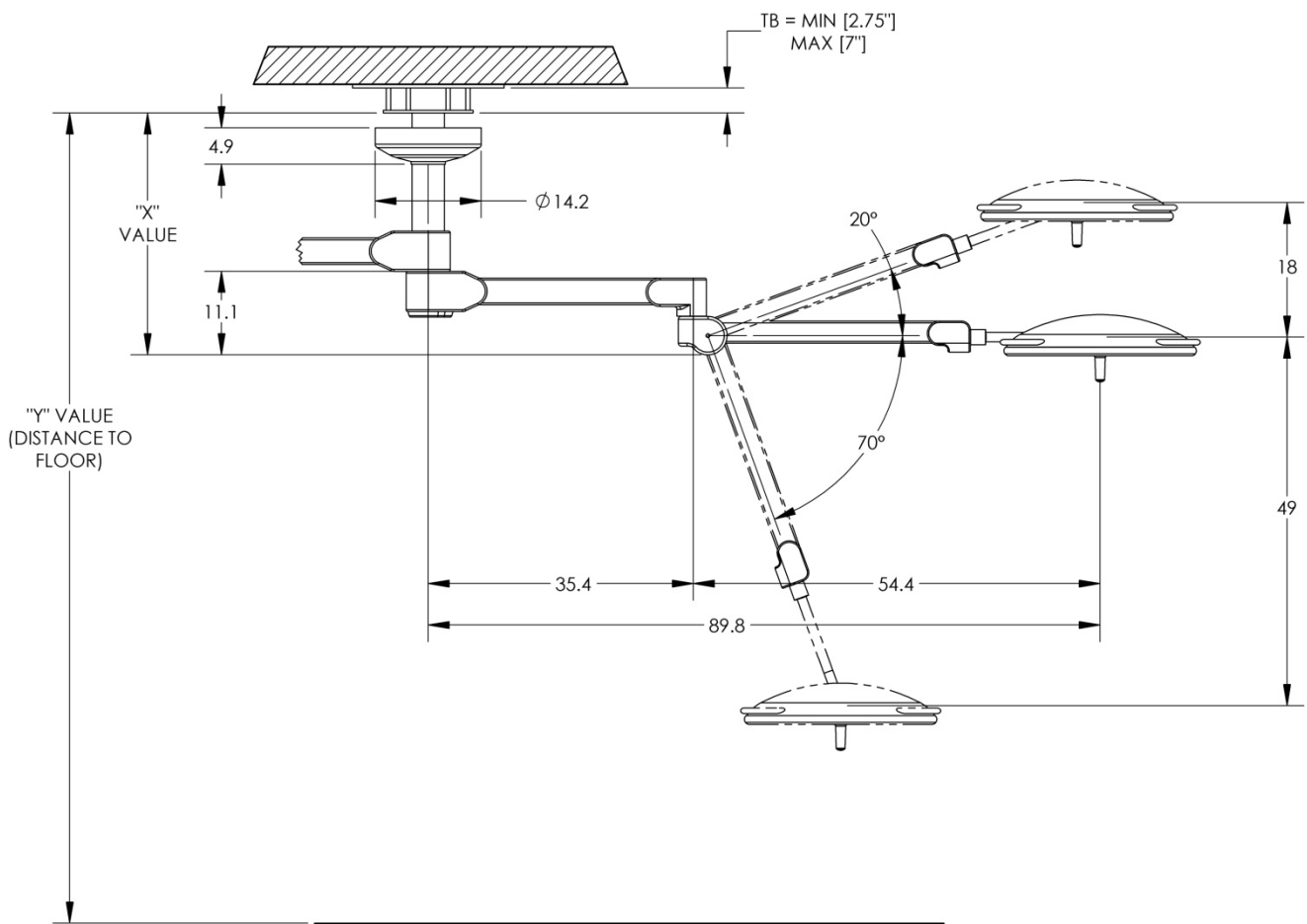

Ceiling Rod Calculation, Triple LCH Mount

Use the following table to select the correct length ceiling rod for your application

Ceiling Mounting Height "Y"-Value	Ceiling Rod Length	"X"-Value	Head Room to Bottom of Extension Arm "Y"-Value - X-Value
9'6"/114"	16"	41"	73"
10'0"/120"	16"	38"	82"
10'6"/126"	24"	45"	81"

