

2297B
2296A

4	S-2377	CAPSCREW 10-32 x 1/2 LG. BUTTON HD. SOCKET FOR DISCHARGE SPOUT - NOT SHOWN
4	S-2374	STUD 3/8" x 1 1/4 LG.
4	S-2373	HEX CAP NUT 3/8-16
3	S-2372	MACHINE SCREW 10-32 x 1/2 LG. FLAT HD.
3	S-2370	THUMB SCREW 3/8-20 x 3/4 LG. TYPE S
1	S-2369	MACHINE SCREW 10-32 x 3/8 LG. FIL. HD.
1	2378A	WASHER
1	2365B	COUPLING ASSEMBLY
1	2320B	FUNNEL
1	2319A	GASKET - FUNNEL
1	2318A	GASKET - UPPER STONE
1	2317A	GASKET - LOWER STONE
1	2315A	IMPELLER-NUT
3	2314A	HAND KNOB
3	2313A	STUD
1	2312A	SPLASH RING
1	2311A	INSERT - PROCESS CHAMBER
1	2310B	SPINDLE ASSEMBLY
1	2304A	ADJUSTMENT WHEEL
1	2303A	ADJUSTMENT LOCKSCREW
2	2302A	LOCK STUD
1	2301A	LOCK RING
1	2299D	FRAME
1	2298C	DISCHARGE SPOUT
1	2297B	HEAD
1	2296A	CLAMP RING

1	ISSUE	PART NO.	DESCRIPTION
BILL OF MATERIAL			
MOREHOUSE EQUIPMENT COMPANY			
LOS ANGELES, CALIFORNIA			
4-20	2297B	REV. 8-6-53	DVB
1	2297B	CHECKED	
1	2297B	APPROVED	
SCALE FULL SIZE			1
MATERIAL			1
TOLERANCE ON MACHINED FRACTIONAL DIMENSIONS			1
			2300 C

2-25-04: 2:157PM:

20

2310B

LET. CHANGE DATE BY

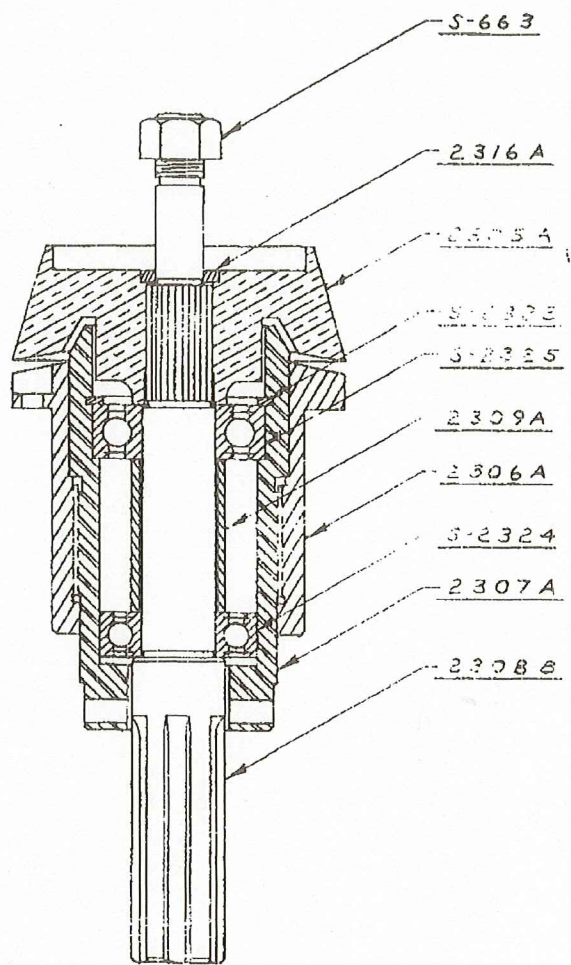

1	S-2325	BEARING
1	S-2324	BEARING
1	S-2323	RETAINING RING
1	S-663	HEX. NUT 3/8"-24
1	2316A	WASHER
1	2309A	SPACER
1	2308B	SPINDLE
1	2307A	ADJUSTING SLEEVE
1	2306A	LINER
1	2305A	ROTOR PLATE

1	REQ'D.	PART NO.	DESCRIPTION
	BILL OF MATERIAL		
1	MOREHOUSE EQUIPMENT COMPANY		
	LOS ANGELES, CALIFORNIA		
	DRAWN 11-17-52 DJB		
1	CHECKED		SPINDLE ASSEMBLY
	APPROVED		
1	SCALE FULL SIZE		DRWG. & PART NO.
	MATERIAL		
TOLERANCE ON MACHINED FRACTIONAL DIMENSIONS			

2-25-04: 2:157PM:

19 21