

COPRINOX

FILTER

Code n° FX 002 0276 Location ref: 08 G2

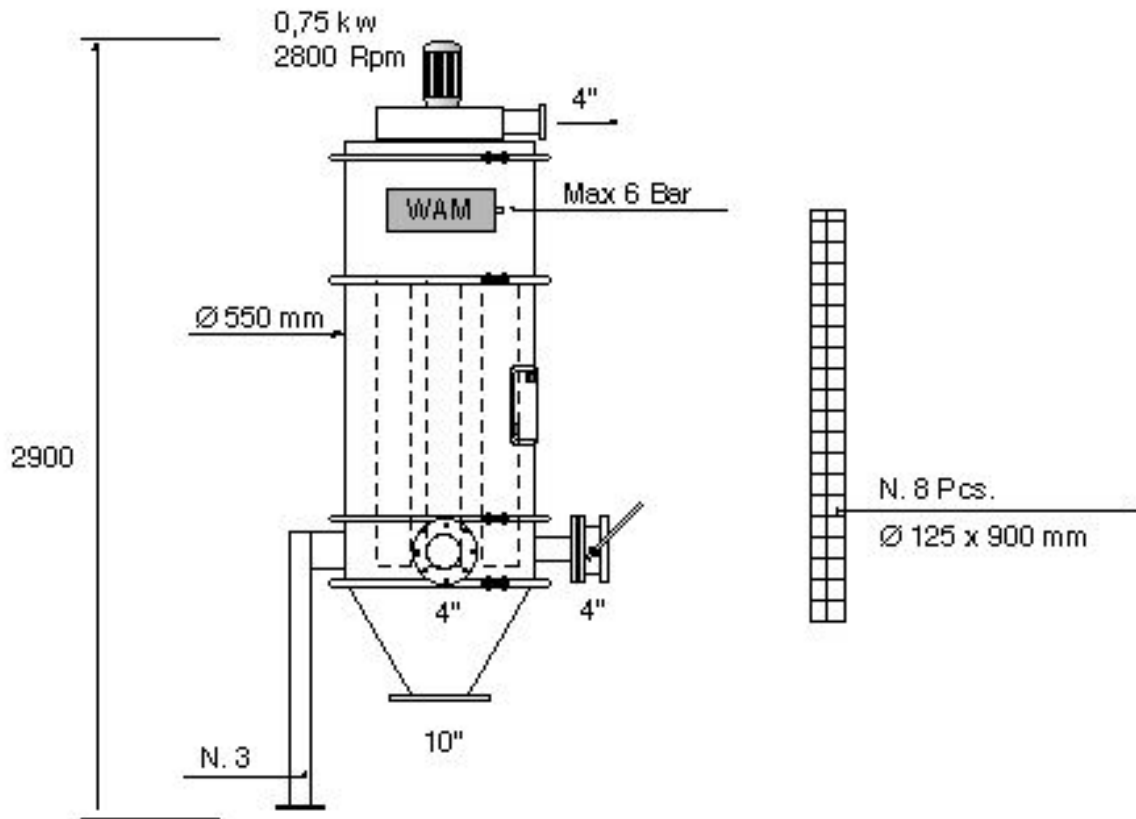

FILTERING SURFACE m² <u>2,8</u>	SHELL SIDE	JACKET/COIL SIDE
Design Pressure KG/cm2 Design Temperature °C Material	AISI 304	
FILTER TYPE: AIR FILTER		
Cake volume liters: _____ Filtering elements n° <u>8</u> Thickness mm: _____	Installed power HP: <u>1</u> Drive speed RPM: <u>2800</u>	
ANCC or ISPESL certification: <u>NOT</u> Availability in stock n° <u>01</u> units	NOZZLE DIMENSIONS	
MANUFACTURER: <u>WAM</u>	Pos	Service
<input checked="" type="checkbox"/> USED <input type="checkbox"/> USED RECONDITIONED <input type="checkbox"/> UNUSED	A	
	B	
	C	
	D	
	E	
WEIGHT (approx) Kg _____	NOTE _____	