

**WINKLER+  
DÜNNEBIER**

**W+D**

**49/49L**

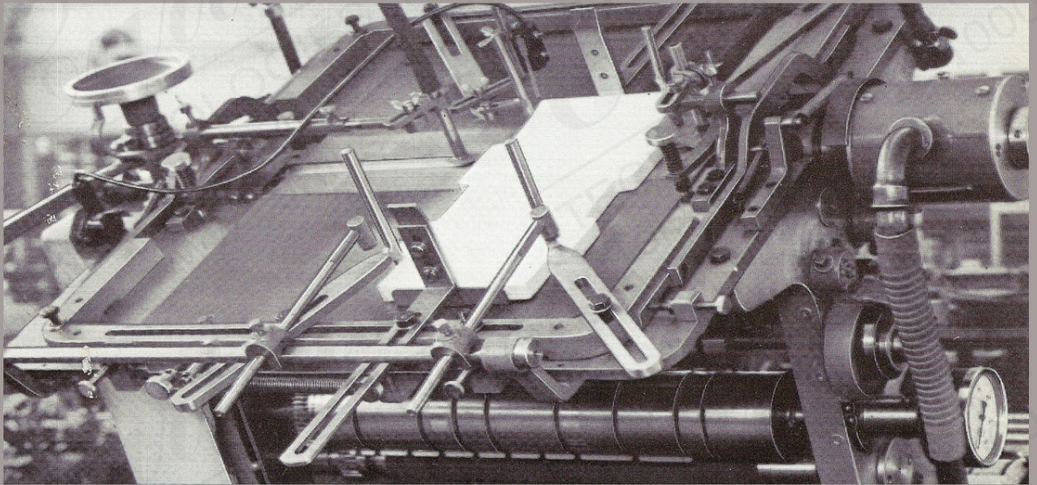

## **Rotary Pocket Machines**



For the manufacture of pockets with shape gumming up to the edge and without seal flap gumming, with side or centre seam gumming we recommend our machine HELIOS 49, while pockets with latex gumming can be made on our machine HELIOS 49 L.

These machines are also suitable for manufacturing powder-proof pockets, pockets with outer side flaps (photo wallets) as well as double photo wallets with and without central crease. The side flap gumming unit is sluable. The seal flap gum is evenly dried by means of a drying wheel and a hot air circulating system.

A special construction of the respective gumming units allows bottom and side flap gumming to the edge which results in very exactly folded pockets.

If the blanks have to be printed the complementary printing machine HELIOS 149 G can be coupled

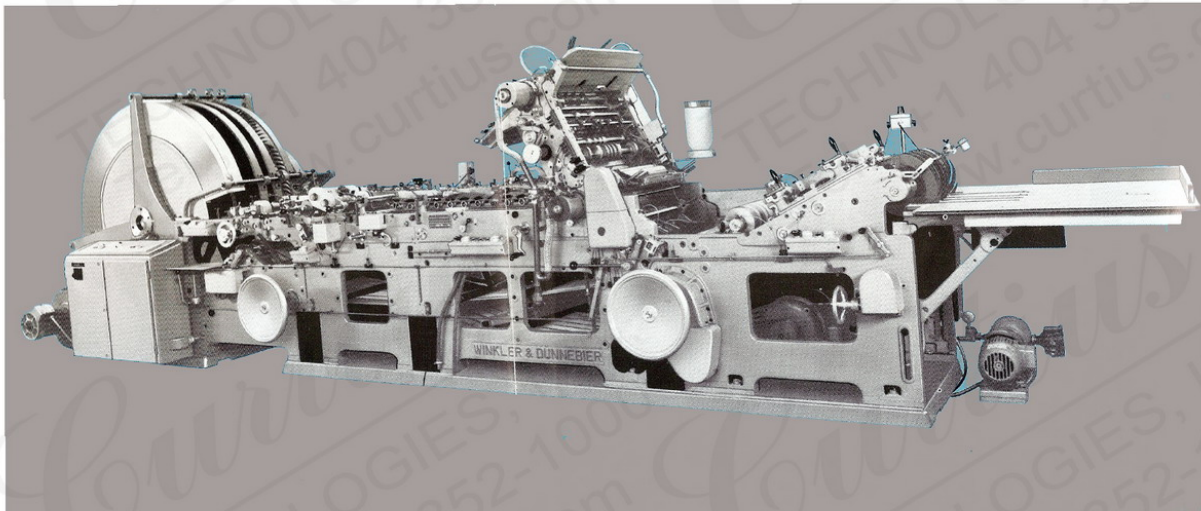



**49**

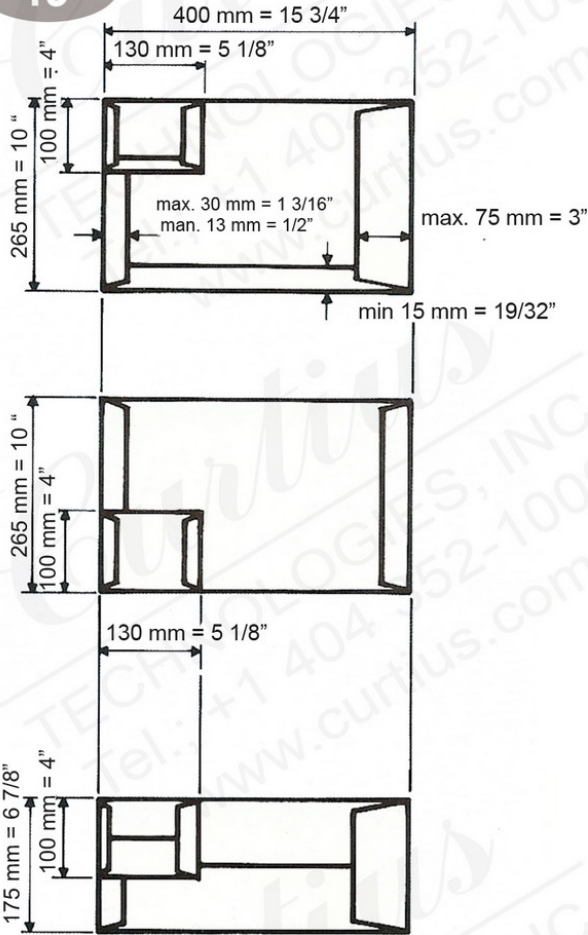

**size rangesx**

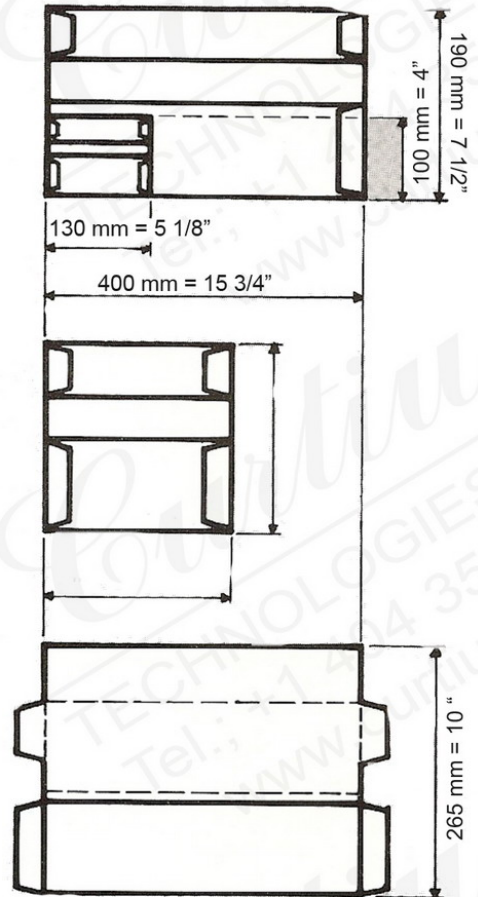

**49L**

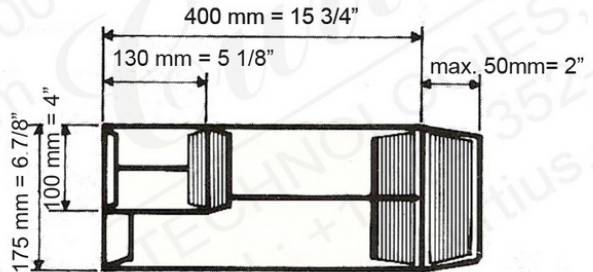
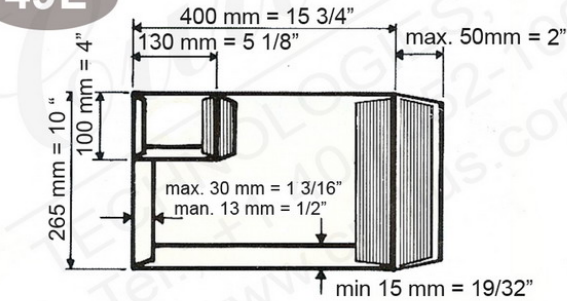

### floor space required

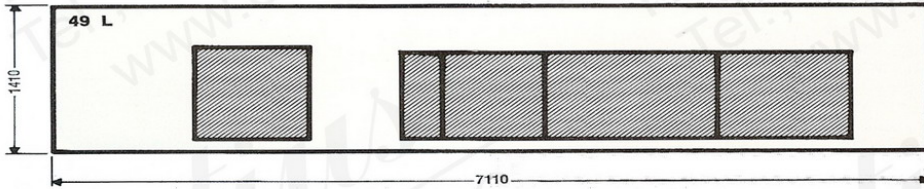
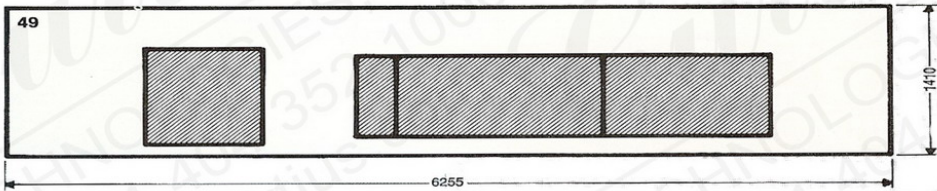

**49**

60 — 140 g/m<sup>2</sup>

paper weights

505 mm — 19<sup>7</sup>/<sub>8</sub>"

max. paper width

180

max. output pockets per minute

power required

10 kVA

motors abt.

12 kW

electrical heater abt.

4450 kg

net weight abt.

**49L**

60 — 140 g/m<sup>2</sup>

paper weights

505 mm — 19<sup>7</sup>/<sub>8</sub>"

max. paper width

180

max. output pockets per minute

power required

10 kVA

motors abt.

12 kW

electrical heater abt.

4900 kg

net weight abt.

