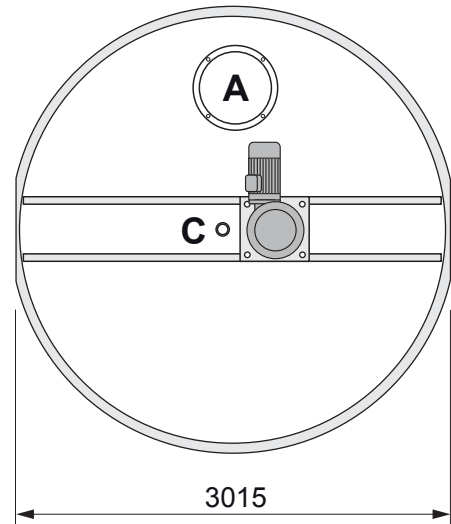
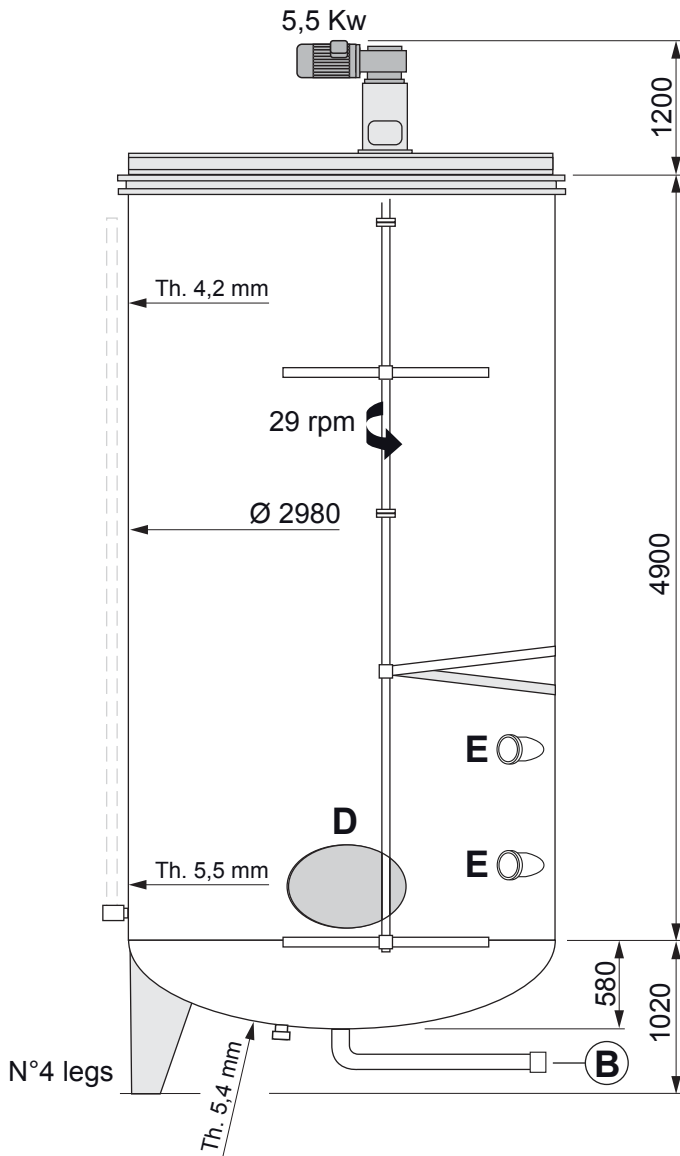

# COPRINOX

# VESSEL

Code n° **VV 370 1585**Location ref: **19 B4**CAPACITY LITERS **37.000**

SHELL SIDE

JACKET/COIL SIDE

Design Pressure KG/cm2  
Design Temperature °C  
Material

Atm

--

--

--

AISI 304

--

ANCC or ISPESL certification: **N.A**Availability in stock n° **1** units

## NOZZLE DIMENSIONS

Pos	Service	Size
A	Manhole	DN500
B	Product outlet	DN100
C	CIP - sprayball	DN50
D	Manhole	
E	Product inlet / service	DN100

MANUFACTURER

- USED  
 USED RECONDITIONED  
 UNUSED

NOTE

WEIGHT (approx) Kg **3600**