

200 Low Profile Portable Silo



200 Barrel Low Profile Portable

- 8'-6" Wide x 25'-9" Overall Length
- Positive Feed Drive Auger System
- 7" Diameter Screw x 17'-0"
- 5 HP Motor and Gear Box Drive
- Heavy Duty Dual Axle Trailer and Tires
- Electric Brakes and Lights Package
- 150 Sq. Ft. Bag Area Dust Collector with Air Vibrator
- Pressure Relief Valve
- (4) Two Speed Trailer Jacks
- 12'-0" Auger Discharge Height
- 4" Fill Pipe with Aluminum Adapter
- 20" Non-Pressurized Inspection Manhole
- (8) Externally Mounted Air Pads with Manifold, Regulator, and Check Valve
- Sandblast, Prime, and Paint
- Standard Colors:
RAL 7038 Gray, RAL 9010 White,
RAL 1001 Tan, RAL 1032 Yellow

Options

- 225 Sq. Ft. Dust Collector
- 330 Sq. Ft. Pulse Jet Dust Collector
- Bin Level Indicators
- Single Phase Motor
- Hydraulic Drive Motor
- 16 HP Gas Motor
- Motor Starter Controls
- Manual Air Valve Controls
- Upgrade to 9" Screw Conveyor

Specifications

- Empty Weight 8,000#
- Hitch Weight 2,100#
- 800 Cu. Ft. Capacity
- 37 Ton Capacity (Cement)
- Output Capacity Approximately
7 Cu. Ft. Per Minute (7" Screw
Conveyor)

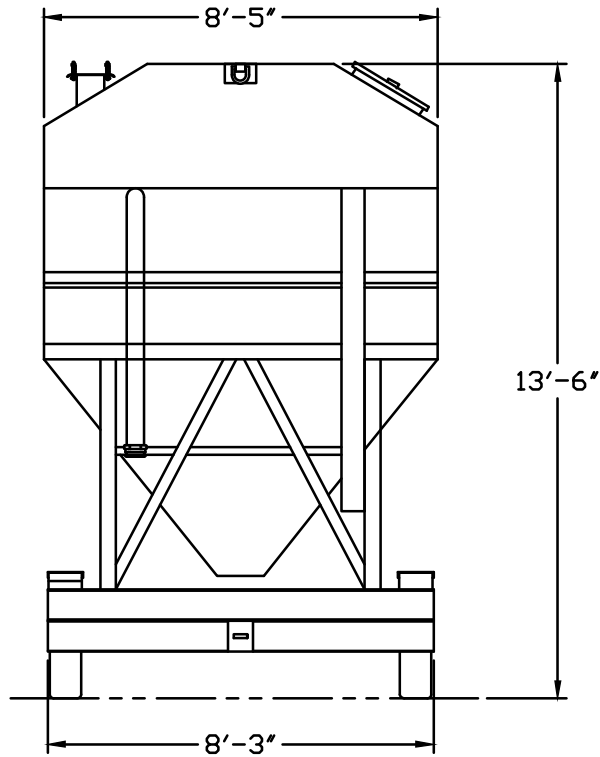

200 Low Profile Portable Silo

