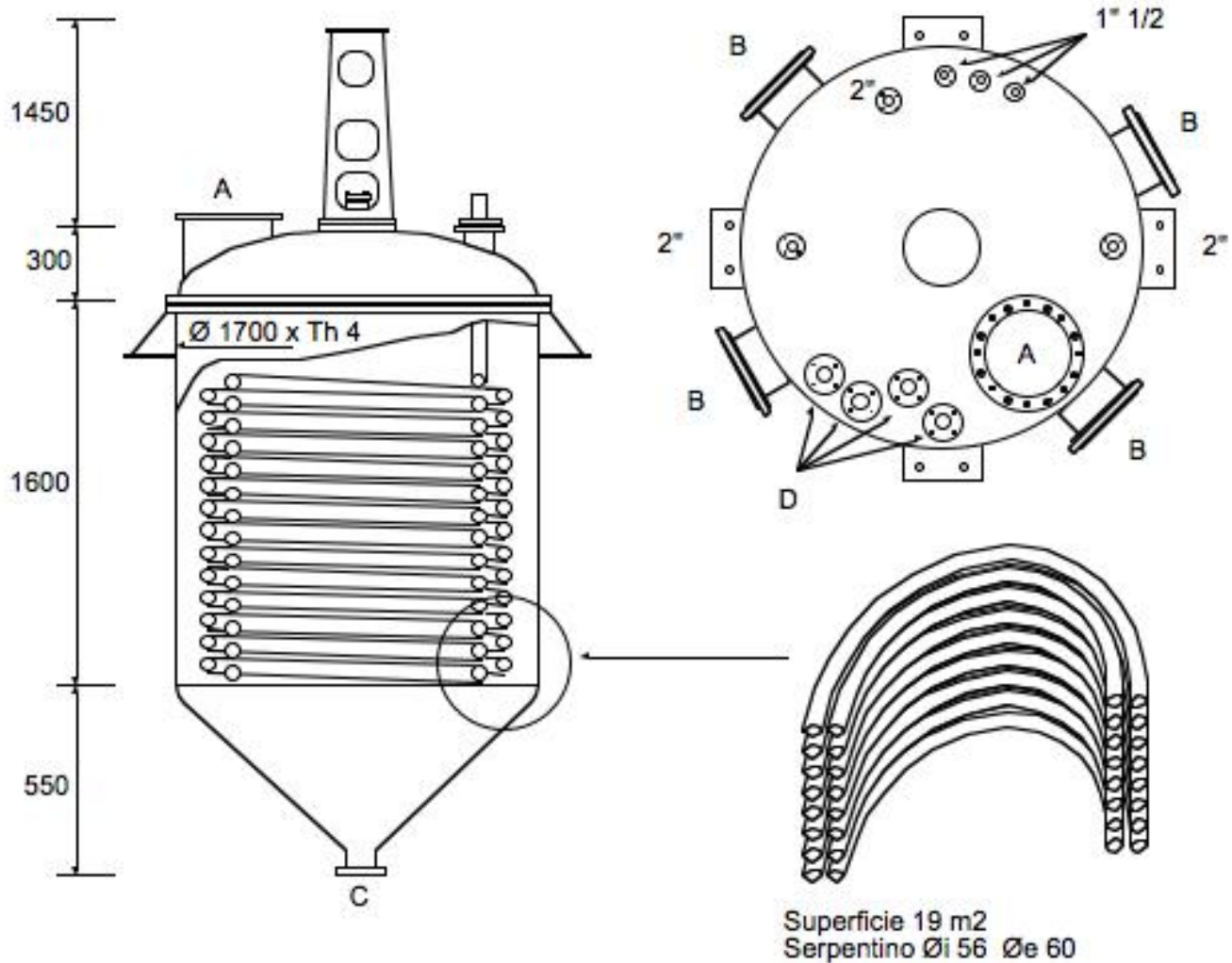

COPRINOX

AGITATED VESSEL

Code n° RAH 045 0851

Location ref: 96 C1

Superficie 19 m2
Serpentino Øi 56 Øe 60

CAPACITY LITERS _____ 4.500 _____	SHELL SIDE	JACKET/COIL SIDE	
Design Pressure KG/cm2 Design Temperature °C Material			
	AISI 304		
ANCC or ISPESL certification: _____ NOT Availability in stock n° _____ 01 _____ units	NOZZLE DIMENSIONS		
MANUFACTURER: _____	Pos	Service	Size inch.
<input checked="" type="checkbox"/> USED <input type="checkbox"/> USED RECONDITIONED <input type="checkbox"/> UNUSED	A	Man hole	16"
	B		6"
	C	Product outlet	4"
	D	Heating medium in-out	2"
	E		
WEIGHT (approx) Kg _____	NOTE	Manca l'agitatore	