

SERVICE MANUAL

Isolette® Infant Incubator From Hill-Rom Air-Shields

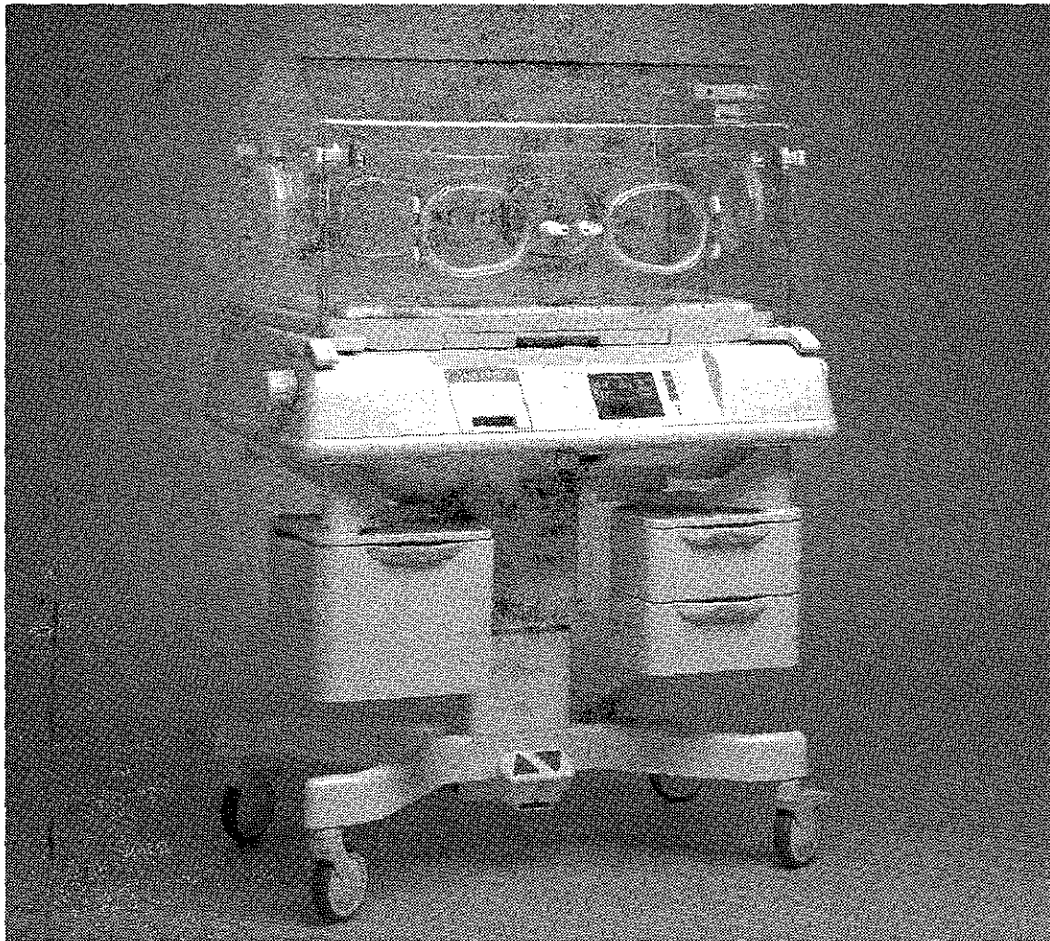

Product No. C2000

For Parts or Technical Assistance
USA (800) 445-3720 Canada (800) 267-2337
International: Contact your distributor.

man223rf

11
12
13
14
15
16
17
18
19
20
21
22
23
24
25
26
27
28
29
30
31
32
33
34
35
36
37
38
39
40
41
42
43
44
45
46
47
48
49
50
51
52
53
54
55
56
57
58
59
60
61
62
63
64
65
66
67
68
69
70
71
72
73
74
75
76
77
78
79
80
81
82
83
84
85
86
87
88
89
90
91
92
93
94
95
96
97
98
99
100

Isolette® Infant Incubator Service Manual

Revisions

Revision Letter	Pages Affected	Date
Original Issue		March, 1998
A	1	November, 1998
B	vii, 1-4, 2-7, 2-8A, 2-8D, 2-12, 2-19, 4-4, 4-5, 4-8 and 4-12	February, 1999
C	2-2, 2-8, 2-8B, 2-8C, 5-1, 5-2, 6-30 through 6-34, 6-36, 6-38, 6-40 through 6-42, 6-44 through 6-46, 6-70, 6-71, 6-74 through 6-77, 6-97A, 6-97B, 7-3	May, 1999
D	4-6, 4-7, 6-2, 6-51	November, 1999
E	Cover, Warranty, A, B, ii through vi, viii through x, 1-3, 2-9, 2-11, 3-2, 3-5, 3-7 through 3-9, 3-13, 3-14, 3-16, 3-30, 4-3, 5-4 through 5-18, 6-1, 6-4 through 6-6, 6-52 through 6-55, 6-55A through 6-55D, 6-56, 6-57, 6-57A through 6-57F, 6-58, 6-59, 7-4 through 7-24	March, 2000
F	All	May, 2001

man223rf

© 2001 by Hill-Rom Services, Inc. ALL RIGHTS RESERVED.

No part of this text shall be reproduced or transmitted in any form or by any means, electronic or mechanical, including photocopying, recording, or by any information or retrieval system without written permission from Hill-Rom Services, Inc. (Hill-Rom).

Seventh Edition

First Printing 1998

Printed in the USA

Air-Shields® is a registered trademark of Hill-Rom Services, Inc.

Critter Covers® is a registered trademark of Hill-Rom Services, Inc.

Hill-Rom Air-Shields™ is a trademark of Hill-Rom Services, Inc.

Hill-Rom® is a registered trademark of Hill-Rom Services, Inc.

Isolette® is a registered trademark of Hill-Rom Services, Inc.

Kleenaseptic® is a registered trademark of Metrex Research Corporation.

Loctite® is a registered trademark of Loctite Corporation.

Motorola® is a registered trademark of Motorola, Inc.

Oilite® is a registered trademark of Beemer Precision, Incorporated.

Teflon® is a registered trademark of E. I. du Pont and de Nemours and Company.

Velcro® is a registered trademark of Velcro Industries, BV (a Dutch corporation).

The information contained in this manual is subject to change without notice. Hill-Rom makes no commitment to update or keep current, the information contained in this manual.

The only product warranty intended by Hill-Rom is the express, written warranty accompanying the bill of sale to the original purchaser. Hill-Rom makes no other warranty, express or implied, and in particular, makes no warranty of merchantability or fitness for a particular purpose.

Additional copies of this manual can be obtained from Hill-Rom.

To order additional copies of this manual, call (800) 445-3720, and place a parts order for part number man223rf.

Revisions

NOTES:

Table of Contents

Chapter 1: Introduction

Purpose	1 - 3
Audience	1 - 3
Organization	1 - 3
Chapter 1: Introduction	1 - 3
Chapter 2: Troubleshooting Procedures	1 - 3
Chapter 3: Theory of Operation	1 - 3
Chapter 4: Removal, Replacement, and Adjustment Procedures	1 - 3
Chapter 5: Parts List	1 - 4
Chapter 6: General Procedures	1 - 4
Chapter 7: Accessories	1 - 4
Typographical Conventions	1 - 5
Technical Definitions	1 - 6
Introduction	1 - 8
Overview	1 - 8
Operating Precautions	1 - 8
Features	1 - 8
Oval Access Doors	1 - 8
Mattress Tilt Mechanism	1 - 8
Pedestal Stand Assembly	1 - 8
Oxygen Control System (Optional)	1 - 8
Humidity System (Optional)	1 - 8
Weighing Platform (Optional)	1 - 9
Specifications	1 - 10
Physical Description	1 - 10
Electrical Description	1 - 11
Oxygen Control Description	1 - 12

Table of Contents

Regulations, Standards, and Codes	1 - 12
Model Identification and Series Changes	1 - 13
Safety Tips	1 - 15
Warning and Caution Labels	1 - 20
Chapter 2: Troubleshooting Procedures	
Getting Started	2 - 3
Initial Actions	2 - 3
Function Checks	2 - 4
Final Actions	2 - 14
Alarms	2 - 15
High and Low Air and Skin Temperature Alarms	2 - 15
Alarm Messages	2 - 16
System Failure Messages	2 - 24
Diagnostic Menus	2 - 25
Entering the Diagnostic Menus	2 - 25
Diagnostic Information Menu	2 - 27
System Test Menu	2 - 28
Key Check Display	2 - 31
Data Summary Menu	2 - 32
Variable Height Adjustable Pedestal/Stand Will Not Move Up or Down	2 - 34
Low Set Temperature Alarm Activated	2 - 36
Oxygen Concentration is Low	2 - 38
Oxygen Concentration is High	2 - 41
Chapter 3: Theory of Operation	
Controller Assembly	3 - 3
Variable Height Adjustable Pedestal/Stand Assembly	3 - 7
Hood/Shell Assembly	3 - 8
Theory of Operation	3 - 12
Electrical System	3 - 12
Sensor Module	3 - 12
Controller	3 - 16

Impeller Movement Detector (IMD) P.C. Board	3 - 17
Fan Motor	3 - 18
Heater Power	3 - 18
Humidity Heater Power	3 - 18
Air System	3 - 22
Overall Functional Description	3 - 22
Air Mode	3 - 24
Skin Mode	3 - 24
Oxygen Control	3 - 25
Humidity Control Valve	3 - 25
Hardware	3 - 25
Weighing Mode	3 - 25
Trend Displays	3 - 26
Interface Connections	3 - 26
RS-232 Serial Port Protocol	3 - 27

Chapter 4: Removal, Replacement, and Adjustment Procedures

Controller	4 - 3
Removal	4 - 3
Replacement	4 - 4
Sensor Module	4 - 5
Removal	4 - 5
Replacement	4 - 5
Oxygen Sensor Cell	4 - 6
Removal	4 - 6
Replacement	4 - 7
Air Intake Microfilter	4 - 8
Removal	4 - 8
Replacement	4 - 8
Check Valve Assembly	4 - 9
Removal	4 - 9
Replacement	4 - 10

Table of Contents

Motor Assembly	4 - 11
Removal	4 - 11
Replacement	4 - 11
Access Panel	4 - 13
Removal	4 - 13
Replacement	4 - 13
Iris Entry Port Sleeve	4 - 15
Removal	4 - 15
Replacement	4 - 15
Access Door Latch	4 - 16
Removal	4 - 16
Replacement	4 - 16
Access Door and Access Door Pivot Hinge	4 - 17
Removal	4 - 17
Replacement	4 - 17

Chapter 5: Parts List

Warranty	5 - 3
Service Parts Ordering	5 - 5
Exchange Policy	5 - 7
In-Warranty Exchanges	5 - 7
Out-of-Warranty Exchanges	5 - 7
Recommended Spare Parts	5 - 8
Incubator Hood and Shell Assembly	5 - 10
High Dual Access Hood Assembly with Two Iris Ports	5 - 14
High Front Access Hood Assembly with Two Access Doors and Two Iris Ports ("00" Series Model Only)	5 - 18
High Front Access Hood Assembly with Two Access Doors and Two Iris Ports ("01" Series Model Only)	5 - 22
High Dual Access Hood Assembly with One Access Door and One Iris Port ("00" Series Model Only)	5 - 26
High Dual Access Hood Assembly with One Access Door and One Iris Port ("01" Series Model Only)	5 - 30

High Dual Access Hood Assembly with Two Access Doors (“00” Series Model Only) 5 - 34

High Dual Access Hood Assembly with Two Access Doors (“01” Series Model Only) 5 - 38

High Front Access Hood Assembly with Four Access Doors (“00” Series Model Only) 5 - 42

High Front Access Hood Assembly with Four Access Doors (“01” Series Model Only) 5 - 46

Access Panel Front Assembly (“00” Series Model Only) 5 - 50

Access Panel Front Assembly (“01” Series Model Only) 5 - 52

Access Panel Rear Assembly (“00” Series Model Only) 5 - 54

Access Panel Rear Assembly (“01” Series Model Only) 5 - 56

Shell Assembly (“00”, “01”, and “02” Series Models Only) 5 - 58

Shell Assembly (“03” Series Model Only) 5 - 62

Top Shell Assembly (“03” Series Model Only) 5 - 64

Controller Assembly (Model C2C-2 Only) 5 - 68

Enclosure Assembly (Model C2C-2 Only) 5 - 70

Front Panel Assembly (Model C2C-2 Only) 5 - 72

Interface/Power Supply Assembly (Model C2C-2 Only) 5 - 74

Sensor Module Assembly 5 - 76

Pedestal Stand Assembly (“00” Series Model Only) 5 - 78

Pedestal Stand Assembly (“01” Series and Higher Models Only) 5 - 82

Variable Height Adjustable Pedestal Stand Assembly 5 - 86

Hood/Shell and Pedestal Stand Assembly Attachment 5 - 90

Foot Switch Assembly, Front 5 - 92

Foot Switch Assembly, Rear 5 - 93

Check Valve Assembly 5 - 94

Scale Assembly 5 - 96

Sensor Module P.C. Board Assembly—P/N 83 005 70 5 - 98

Scale P.C. Board Assembly—P/N 83 600 70 5 - 102

Impeller Movement Detector P.C. Board Assembly—P/N 83 103 70 5 - 106

IV Pole Assembly (Accessory) 5 - 108

Table of Contents

High Monitor Shelf Assembly (Accessory) 5 - 110
Swivel Drawer Assembly (Accessory) 5 - 112
Humidity System (Accessory) 5 - 114
Humidity System (Accessory) (“02” Series Model Only) 5 - 118
Evaporator Reservoir Assembly (“02” Series Model Only) 5 - 122
Oxygen System (Accessory) 5 - 124
Ventilator Tube Support (Accessory) 5 - 127
Oxygen Tank Bracket (Accessory) 5 - 128

Chapter 6: General Procedures

Cleaning 6 - 3
 General Cleaning 6 - 3
 Steam Cleaning 6 - 4
 Cleaning Hard to Clean Spots 6 - 4
 Disinfecting 6 - 4
 Using Cleaning Agents 6 - 4
 Skin Temperature Probe 6 - 4
 Access Door Gaskets and Tubing Access Ports 6 - 4
 Humidity Tray Reservoir 6 - 5
 Controller, Shell, and Pedestal Stand 6 - 5
 Hood, Sensor Module, and Inner Walls 6 - 5
 Heater Radiator and Fan Impeller 6 - 7
 Mattress Tray, Main Deck, Heater/Impeller Cover, and Mattress Tilt Bars 6 - 7
 Air Intake Microfilter 6 - 7
 Disassembly 6 - 7
 Assembly 6 - 13
Component Handling 6 - 15
 P.C. Board 6 - 15
Lubrication Requirements 6 - 16
Preventive Maintenance 6 - 17
 Preventive Maintenance Schedule 6 - 18
 Preventive Maintenance Checklist 6 - 19

Installation and Set-up 6 - 20

 Unpacking 6 - 20

 Assembling 6 - 20

 Setting Up 6 - 22

Oxygen Sensor Calibration 6 - 24

 Room Air—21% Oxygen 6 - 24

 100% Oxygen 6 - 25

Oxygen Concentration Test 6 - 27

Weighing Scale Calibration 6 - 28

Current Leakage Test 6 - 29

 Set-Up 6 - 29

 Procedure 6 - 29

Tool and Supply Requirements 6 - 30

Chapter 7: Accessories

Accessories 7 - 3

Weighing Scale 7 - 4

 Installation 7 - 4

 Removal 7 - 5

Oxygen System 7 - 6

 Installation 7 - 6

 100% Calibration Fixture Installation 7 - 9

 Removal 7 - 10

Humidity System (“00” and “01” Series Models Only) 7 - 11

 Installation 7 - 11

 Removal 7 - 14

Humidity System (“02” Series Model Only) 7 - 15

 Installation 7 - 15

 Removal 7 - 18

NOTES:

Chapter 1

Introduction

Chapter Contents

Purpose	1 - 3
Audience	1 - 3
Organization	1 - 3
Chapter 1: Introduction	1 - 3
Chapter 2: Troubleshooting Procedures	1 - 3
Chapter 3: Theory of Operation	1 - 3
Chapter 4: Removal, Replacement, and Adjustment Procedures	1 - 3
Chapter 5: Parts List	1 - 4
Chapter 6: General Procedures	1 - 4
Chapter 7: Accessories	1 - 4
Typographical Conventions	1 - 5
Technical Definitions	1 - 6
Introduction	1 - 8
Overview	1 - 8
Operating Precautions	1 - 8
Features	1 - 8
Oval Access Doors	1 - 8
Mattress Tilt Mechanism	1 - 8
Pedestal Stand Assembly	1 - 8
Oxygen Control System (Optional)	1 - 8
Humidity System (Optional)	1 - 8
Weighing Platform (Optional)	1 - 9
Specifications	1 - 10

Chapter 1: Introduction

Physical Description	1 - 10
Electrical Description	1 - 11
Oxygen Control Description	1 - 12
Regulations, Standards, and Codes	1 - 12
Model Identification and Series Changes	1 - 13
Safety Tips	1 - 15
Warning and Caution Labels	1 - 20

Purpose

This manual provides requirements for the Isolette® Infant Incubator normal operation and maintenance. It also includes parts lists (in chapter 5) for ordering replacement components.

Audience

This manual is intended for use by only facility-authorized personnel. Failure to observe this restriction can result in severe injury to people and serious damage to equipment.

Organization

This manual contains seven chapters.

Chapter 1: Introduction

In addition to a brief description of this service manual, chapter 1 also provides a product overview.

Chapter 2: Troubleshooting Procedures

Repair analysis procedures are contained in this chapter. Use these procedures to gather information, identify the maintenance need, and verify the effectiveness of the repair.

Chapter 3: Theory of Operation

This chapter describes the application of the mechanical, electrical, and hydraulic systems employed in this product.

Chapter 4: Removal, Replacement, and Adjustment Procedures

Chapter 4 contains the detailed maintenance procedures determined necessary in chapter 2.

Chapter 5: Parts List

This chapter contains the warranty, part-ordering procedure, and illustrated parts lists.

Chapter 6: General Procedures

Cleaning, preventive maintenance, and other general procedures are described in this chapter.

Chapter 7: Accessories

A list of additional products, that can be used in conjunction with the Isolette® Infant Incubator, is available in chapter 7. Installation procedures for these accessories are also included.

Typographical Conventions

This manual contains different typefaces and icons designed to improve readability and increase understanding of its content. Note the following examples:

- Standard text—used for regular information.
- **Boldface text**—emphasizes a word or phrase.
- **NOTE:**—sets apart special information or important instruction clarification.
- The symbol below highlights a **WARNING** or **CAUTION**:

Figure 1-1. Warning and Caution



- A **WARNING** identifies situations or actions that may affect patient or user safety. Disregarding a warning could result in patient or user injury.
- A **CAUTION** points out special procedures or precautions that personnel must follow to avoid equipment damage.
- The symbol below highlights an **ELECTRICAL SHOCK HAZARD WARNING**:

Figure 1-2. Electrical Shock Hazard Warning



Technical Definitions

This manual contains different technical terms. Note the following definitions:

- **Incubator temperature**—The air temperature at a point 4" (10 cm) above and centered over the mattress surface.
- **Control temperature**—The temperature controller's set point selected by the user.
- **Average incubator temperature**—The average of the maximum and minimum incubator temperatures achieved during temperature equilibrium.
- **Incubator temperature equilibrium**—The condition reached when the average incubator temperature does not vary more than 1°C over a period of one hour. These measurements are taken at the control temperatures of 90°F (32°C) and 97°F (36°C).
- **Temperature uniformity**—The amount by which the average temperature of each of four points 4" (10 cm) above the mattress surface differs from the average incubator temperature at incubator temperature equilibrium.
- **Temperature rise time**—The time required for the incubator temperature to rise 20°F (11°C), when the air control temperature is at least 22°F (12°C) above the ambient temperature.
- **Temperature overshoot**—The amount by which incubator temperature exceeds average incubator temperature at incubator temperature equilibrium as a result of an increase in control temperature. Additionally, the incubator temperature equilibrium shall be restored within 15 min as a result of an increase in control temperature value.
- **Temperature correlation: Incubator temperature versus control temperature**—The amount the air temperature indicator at incubator temperature equilibrium differs from the control temperature.
- **Temperature correlation: Temperature indicator versus control temperature**—The amount the air temperature indicator in air mode at incubator temperature equilibrium differs from the control temperature.
- **Measurement points**—Measurements are taken at five points in a plane parallel to and 4" (10 cm) above the mattress surface (see figure 1-5 on page 1-7). One point is 4" (10 cm) above the center of the mattress; the remaining four points are the centers of four areas formed by lines that divide both the width and length into two parts.

Figure 1-3. Measurement Points

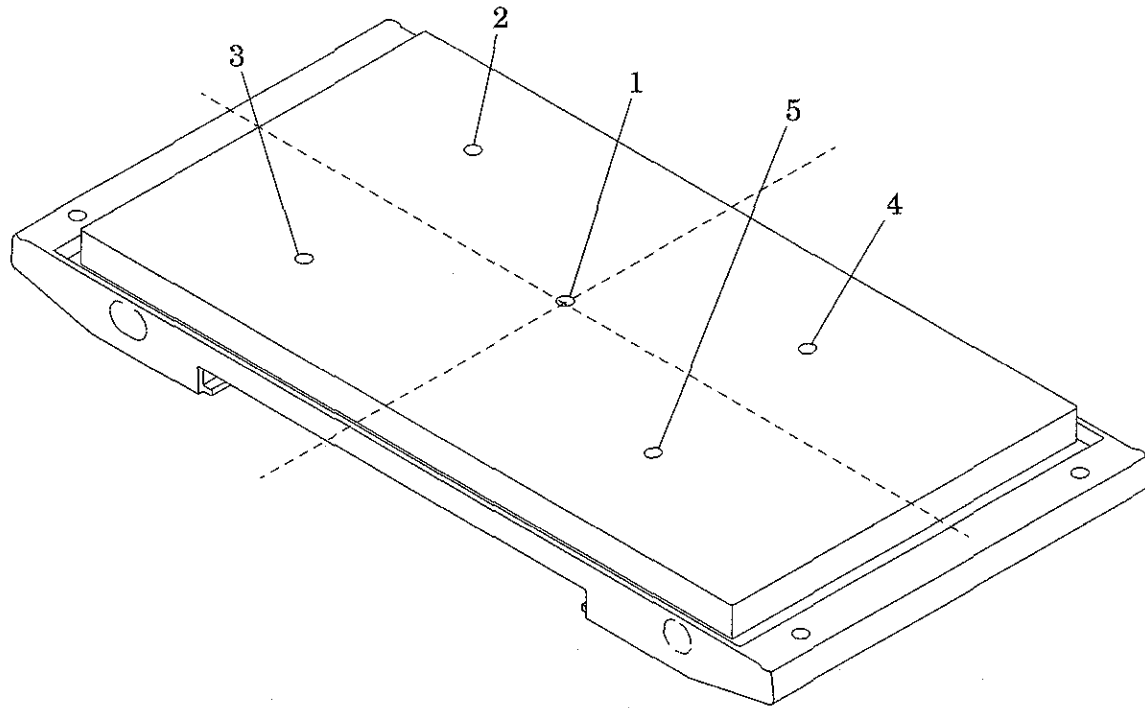

m223f117

Introduction

Overview

On the Isolette® Infant Incubator, skin or air temperature control is selected by a front panel key. Instrumentation includes digital displays for air and skin temperature, a Trend display of two skin temperatures, air temperature, and heater power with user-selectable intervals of 2, 4, 8, 12, and 24 hours. Optional Trend displays of oxygen concentration, weight, and humidity are also available. A comprehensive visual and audible alarm system is provided.

Operating Precautions

For additional operating precautions for the Isolette® Infant Incubator and its accessories, refer to the *Isolette® Infant Incubator User Manual*.

Features

Oval Access Doors

Dual access doors are provided with a quiet latch.

Mattress Tilt Mechanism

A mattress tilt mechanism is provided, and is continuously variable from 0° to 12° from either end.

Pedestal Stand Assembly

The pedestal stand assembly is available in two models: fixed height and variable height adjustable.

Oxygen Control System (Optional)

The oxygen control system monitors and controls the oxygen concentration level within the incubator hood environment.

Humidity System (Optional)

The humidity system monitors and controls the humidity level within the incubator hood environment.

Weighing Platform (Optional)

A weighing platform located under the mattress measures the weight of the infant.

Specifications

Physical Description

For Isolette® Infant Incubator physical specifications, see table 1-1 on page 1-10.

Table 1-1. Physical Specifications

Feature	Dimension
Height from floor (fixed pedestal stand model)	56" ± ½" (142 cm ± 12.7 mm)
Height from floor (variable height adjustable model)	52½" ± ½" to 60" ± ½" (133.35 cm ± 12.7 mm to 152 cm ± 12.7 mm)
Mattress to floor (fixed pedestal stand model)	39¾" ± ½" (100.97 cm ± 12.7 mm)
Mattress to floor (variable height adjustable model)	35½" ± ½" to 43½" ± ½" (90.17 cm ± 12.7 mm to 110.49 cm ± 12.7 mm)
Depth	< 23½" (59.69 cm)
Overall width with tilt knobs	< 41" (104 cm)
Weight (fixed pedestal stand model without options or accessories)	195 lb (89 kg)
Weight (variable height adjustable model without options or accessories)	200 lb (91 kg)
IV pole maximum static load	10 lb (5 kg)
Monitor shelf maximum static load	25 lb (11 kg)
Mattress tray width	31" (79 cm)
Mattress tray depth	16" (41 cm)
Mattress Trendelenburg/Reverse Trendelenburg tilt	Continuously variable to 12° ± 1°
Environmental temperature operating range	68°F to 86°F (20°C to 30°C)
Storage temperature	-22°F to 140°F (-6°C to 60°C)
Humidity display accuracy (10% to 90% @ 68°F to 104°F (20°C to 40°C))	± 6% RH

Electrical Description

For Isolette® Infant Incubator electrical specifications, see table 1-2 on page 1-11.

Table 1-2. Electrical Specifications

Feature	Dimension
Power requirements (100V fixed pedestal stand model)	100V \pm 10%, 50/60 Hz, 990 W maximum
Power requirements (120V fixed pedestal stand model)	120V \pm 10%, 60 Hz, 1188 W maximum
Power requirements (220V and 240V fixed pedestal stand model)	220V or 240V \pm 10%, 50/60 Hz, 2376 W maximum
Power requirements (100V variable height adjustable pedestal stand model)	100V \pm 10%, 50/60 Hz, 990 W maximum
Power requirements (120V variable height adjustable pedestal stand model)	120V \pm 10%, 60 Hz, 1188 W maximum
Power requirements (220V and 240V variable height adjustable pedestal stand model)	220V or 240V \pm 10%, 50/60 Hz, 2376 W maximum
Convenience outlets (100V model)	100V, 100 W maximum
Convenience outlets (120V model)	120V, 300 W maximum
Convenience outlets (220V and 240V models)	220V or 240V, 500 W maximum
Chassis current leakage (110V and 120V model)	300 μ A or less
Chassis current leakage (220V and 240V model)	500 μ A or less

Oxygen Control Description

For Isolette® Infant Incubator oxygen control specifications, see table 1-3 on page 1-12.

Table 1-3. Oxygen Control Specifications

Feature	Dimension
Oxygen display range	18% to 100%
Oxygen display resolution	1% oxygen
Oxygen display accuracy (100% calibration)	$\pm 3\%$
Oxygen display accuracy (21% calibration)	$\pm 5\%$
Oxygen set resolution	1%

Regulations, Standards, and Codes

With respect to the International Electrotechnical Commission (IEC) 601-1, the incubator is Class 1, Type BF.

The mode of operation is continuous operation with short-time loading (variable height adjustable model only).

Model Identification and Series Changes

For Isolette® Infant Incubator model identification, see table 1-4 on page 1-13.

Table 1-4. Model Identification

Model/Series Number	Description
C2000	Isolette® Infant Incubator

For Isolette® Infant Incubator hood/shell assembly series identification, see table 1-5 on page 1-13.

Table 1-5. Series Identification for the Hood/Shell Assembly

Model/Series Number	Description
C2HS-1, C2HS1-400	Isolette® Infant Incubator hood/shell assembly with panel slide latches
C2HS01, C2HS-1, C2HS-1400	Isolette® Infant Incubator hood/shell assembly with pawl latches
C2HS-02	Isolette® Infant Incubator hood/shell assembly with hood lock
C2HS-03	Isolette® Infant Incubator hood/shell assembly with modification 170

For Isolette® Infant Incubator controller series identification, see table 1-6 on page 1-13.

Table 1-6. Series Identification for the Controller

Model/Series Number	Description
C2C-2-00	Isolette® Infant Incubator controller

For Isolette® Infant Incubator fixed pedestal stand assembly series identification, see table 1-7 on page 1-14.

Table 1-7. Series Identification for the Fixed Pedestal Stand Assembly

Model/Series Number	Description
C2STD1-00	Isolette® Infant Incubator fixed pedestal stand assembly with upper and lower column extrusion
C2STD1-01	Isolette® Infant Incubator fixed pedestal stand assembly with upper and lower column weldment
C2STD2-00	Isolette® Infant Incubator fixed pedestal stand assembly

For Isolette® Infant Incubator variable height adjustable pedestal stand assembly series identification, see table 1-8 on page 1-14.

Table 1-8. Series Identification for the Variable Height Adjustable Stand Assembly

Model/Series Number	Description
C2VHA-1-00	Isolette® Infant Incubator variable height adjustable pedestal stand assembly

For Isolette® Infant Incubator humidity system series identification, see table 1-9 on page 1-14.

Table 1-9. Series Identification for the Humidity System

Model/Series Number	Description
C2RH-1-00	Isolette® Infant Incubator humidity system
C2RH-1-01	Isolette® Infant Incubator humidity system
C2RH-2-00	Isolette® Infant Incubator humidity system with manifold assembly

Safety Tips

**WARNING:**

Only facility-authorized personnel should troubleshoot the Isolette® Infant Incubator. Troubleshooting by unauthorized personnel could result in personal injury or equipment damage.

**WARNING:**

To prevent injury or damage to the variable height adjustable pedestal stand when transporting, employ a person of sufficient strength to adequately control the incubator.

**WARNING:**

Do not use the incubator if it fails to function properly. Refer service to qualified personnel. Failure to do so could result in personal injury or equipment damage.

**WARNING:**

A dirty air intake microfilter may affect oxygen concentrations and/or cause carbon dioxide build-up. Check the filter on a routine basis and change at least every 3 months.

**WARNING:**

The heater radiator can be sufficiently hot to cause burns. Permit the heater radiator to cool for at least 20 min before attempting this procedure.

**WARNING:**

If the **Heater Failed** message does not appear and the alarm does not sound within 5 min, turn off the power switch, and replace the airflow probe. Failure to do so can result in damage to the incubator.

**WARNING:**

Follow the product manufacturer's instructions. Failure to do so could result in personal injury or equipment damage.



WARNING:

Make sure that the oxygen supply to the incubator is turned off and that the incubator is disconnected from the oxygen supply when performing cleaning procedures. A fire and explosion hazard exists when cleaning in an oxygen-enriched environment.



WARNING:

A dirty inlet filter may affect oxygen concentration and/or cause carbon dioxide build-up. Be sure the filter is checked on a routine basis commensurate with local conditions. Particularly, if the incubator is used in an unusually dusty environment, more frequent replacements may be necessary.



WARNING:

The heater can be sufficiently hot to cause burns. Avoid removing or touching the heater until the unit has been switched off for at least 45 minutes.



WARNING:

Only facility-authorized personnel should perform preventive maintenance on the Isolette® Infant Incubator. Preventive maintenance performed by unauthorized personnel could result in personal injury or equipment damage.



WARNING:

The administration of oxygen may increase the noise level for the baby within the incubator.



WARNING:

Make sure that the oxygen supply to the incubator is turned off and that the incubator is disconnected from the oxygen supply when performing maintenance procedures. A fire and explosion hazard exists when performing maintenance procedures in an oxygen-enriched environment.

**WARNING:**

The incubator must be attached to the pedestal stand using the bolts provided. Failure to do so could result in the incubator separating from the pedestal stand if sufficiently tilted, particularly with the hood open.

**WARNING:**

To keep the incubator from sliding when parked on an incline, the pedestal/stand front locking casters must be facing down the incline and locked.

**WARNING:**

Oxygen flow rates cannot be used as an accurate indication of oxygen concentration in an incubator. Oxygen concentrations must be continuously monitored with a calibrated oxygen analyzer. Failure to do so could result in personal injury or equipment damage.

**SHOCK HAZARD:**

Make sure that the building power source is compatible with the electrical specifications shown on the right side of the incubator and the variable height adjustable pedestal stand. For proper grounding reliability, connect the power cord only to a properly marked three-wire hospital-grade or hospital-use receptacle. Do not use extension cords.

**SHOCK HAZARD:**

Unplug the unit from its power source. Failure to do so could result in personal injury or equipment damage.

**SHOCK HAZARD:**

Do not expose the unit to excessive moisture. Personal injury or equipment damage could occur.

**CAUTION:**

When using the variable height adjustable pedestal stand, always lower the incubator to its lowest position prior to transport for optimum stability.



CAUTION:

When reconnecting the rear panel connectors, make sure the sensor module cable connector is connected to the sensor module connector, and not the RS-232 connector.



CAUTION:

Replace both oxygen sensor cells at the same time. Failure to do so could result in equipment damage.



CAUTION:

Do not use harsh cleaners, solvents, or detergents. Equipment damage could occur.



CAUTION:

Some chemical cleaning agents may be conductive and/or leave a residue that may permit a build-up of dust or dirt, which may be conductive. Do not permit cleaning agents to contact electrical components. Do not spray cleaning solutions onto any of these surfaces.



CAUTION:

When cleaning the interior of the incubator shell, care must be taken to prevent liquids from entering the motor shaft opening. Equipment damage could occur.



CAUTION:

Alcohol can cause crazing of the clear acrylic hood. Do not use alcohol for cleaning.



CAUTION:

Do not expose the hood assembly to direct radiation from germicidal lamps. Ultraviolet radiation from these sources can cause cracking of gaskets, fading of paint, and crazing of the clear acrylic hood.

**CAUTION:**

Failure to clean the heater radiator and fan impeller could result in sufficient lint build-up to reduce airflow, which will affect temperature control and cause high oxygen concentrations.

**CAUTION:**

Before lifting the incubator hood for cleaning, ensure that all mounted accessories have been removed to prevent possible interference with the raised hood.

**CAUTION:**

To prevent component damage, ensure that your hands are clean, and **only** handle the P.C. board by its edges.

**CAUTION:**

When handling electronic components, wear an antistatic strap. Failure to do so could result in component damage.

**CAUTION:**

For shipping and storage, place the removed P.C. board in an antistatic protective bag. Equipment damage can occur.

**CAUTION:**

Do not use silicone-based lubricants. Equipment damage could occur.

Warning and Caution Labels

Figure 1-4. Warning and Caution Labels

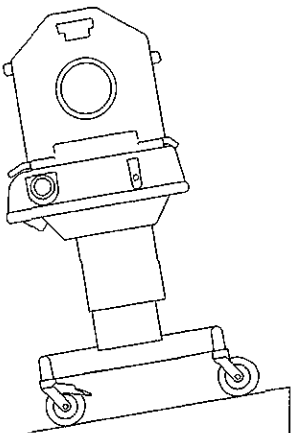
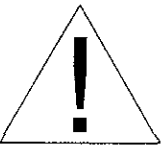
OXYGEN CONCENTRATION GUIDE

OXYGEN SUPPLY	APPROX. OXYGEN %
3 LPM	30-45
6 LPM	40-60
9 LPM	45-75
12 LPM	50-85
15 LPM	60-90

ALLOW OXYGEN CONCENTRATIONS TO STABILIZE

WARNING:
OXYGEN FLOW RATES CAN NOT BE USED AS AN ACCURATE INDICATION OF OXYGEN CONCENTRATIONS IN AN INCUBATOR. OXYGEN CONCENTRATIONS MUST BE CONTINUOUSLY MONITORED WITH A CALIBRATED OXYGEN ANALYZER

INLET 1
↓

IMPORTANT:
INSPECT AIR FILTER
DURING CLEANING
REPLACE IF NECESSARY



WARNING:



- IMPROPER USE OF SUPPLEMENTAL OXYGEN MAY BE ASSOCIATED WITH SERIOUS SIDE EFFECTS. OXYGEN SHOULD ONLY BE ADMINISTERED BY PROPERLY TRAINED PERSONNEL UNDER THE DIRECTION OF A QUALIFIED ATTENDING PHYSICIAN.
- THE OXYGEN CONCENTRATION INSPIRED BY AN INFANT DOES NOT ACCURATELY DETERMINE THE PARTIAL PRESSURE OF OXYGEN (pO₂) IN THE BLOOD. THE pO₂ SHOULD BE MEASURED BY AN ACCEPTED CLINICAL TECHNIQUE WHEN ADVISED BY THE ATTENDING PHYSICIAN.
- FIRE HAZARD - KEEP MATCHES AND OTHER SOURCES OF IGNITION OUT OF ROOM IN WHICH OXYGEN IS IN USE. COMBUSTIBLE MATERIALS ARE EASILY IGNITED AND BURN WITH GREAT INTENSITY IN OXYGEN ENRICHED AIR.
- USE OF ANESTHETIC AGENTS CAN INTERFERE WITH OXYGEN ANALYZER ACCURACY.



 DANGER: EXPLOSION HAZARD DO NOT USE IN THE PRESENCE OF FLAMMABLE ANESTHETICS



IMPORTANT:
DO NOT APPLY OXYGEN TO INLET 1 AND INLET 2 SIMULTANEOUSLY.



OXYGEN CONTROLLER
MAX. PRESSURE 150 PSI
(10.55 Kg/cm²)
MIN. FLOW: 30 LPM



INLET 2
↓



 - CAUTION -
MAXIMUM 2 LBS
WEIGHT (.91 Kg) 

 - CAUTION -
MAXIMUM 5 LBS
WEIGHT (2.2 Kg) 

 - CAUTION -
MAXIMUM 10 LBS
WEIGHT (4.5 Kg) 

 
11 lbs (5.0 kg) 11 lbs (5.0 kg)

m223f091

Page 1 - 20

Isolette® Infant Incubator Service Manual (man223rf)

Chapter 2

Troubleshooting Procedures

2

Chapter Contents

Getting Started	2 - 3
Initial Actions	2 - 3
Function Checks	2 - 4
Final Actions	2 - 14
Alarms	2 - 15
High and Low Air and Skin Temperature Alarms	2 - 15
Alarm Messages	2 - 16
System Failure Messages	2 - 24
Diagnostic Menus	2 - 25
Entering the Diagnostic Menus	2 - 25
Diagnostic Information Menu	2 - 27
System Test Menu	2 - 28
Key Check Display	2 - 31
Data Summary Menu	2 - 32
Variable Height Adjustable Pedestal/Stand Will Not Move Up or Down	2 - 34
Low Set Temperature Alarm Activated	2 - 36
Oxygen Concentration is Low	2 - 38
Oxygen Concentration is High	2 - 41

NOTES:

Getting Started

**WARNING:**

Only facility-authorized personnel should troubleshoot the Isolette® Infant Incubator. Troubleshooting by unauthorized personnel could result in personal injury or equipment damage.

Begin each procedure in this chapter with step 1. Follow the sequence outlined (each step assumes the previous step has been completed). In each step, the normal operation of the product can be confirmed by answering **Yes** or **No** to the statement. Your response will lead to another step in the procedure, a repair analysis procedure (RAP), or a component replacement. If more than one component is listed, replace them in the given order.

To begin gathering information about the problem, start with **Initial Actions**.

To isolate or identify a problem and to verify the repair after completing each corrective action (replacing or adjusting a part, seating a connector, etc.), perform the **Function Checks**.

To verify the repair, perform the **Final Actions** after the Function Checks.

If troubleshooting procedures do not isolate the problem, call Hill-Rom Technical Support at (800) 445-3720 for assistance.

Initial Actions

To gather information from operators concerning problems with the Isolette® Infant Incubator, use Initial Actions. Note symptoms or other information concerning the problem that the operator describes. This information helps identify the probable cause.

1. Someone who can explain the problem is available.

Yes **No**

↓ → Go to "Function Checks" on page 2-4.

2. Ask that person to demonstrate or explain the problem. The problem can be duplicated.

Yes **No**

↓ → Go to "Function Checks" on page 2-4.

3. The problem is a result of improper operator action.

Yes **No**
↓ → Go to "Function Checks" on page 2-4.

4. Instruct the operator to refer to the procedures in the *Isolette® Infant Incubator User Manual*. To ensure proper operation of the Isolette® Infant Incubator, perform the "Function Checks" on page 2-4.

Function Checks

Before the incubator is first placed into service, and after any disassembly for cleaning or maintenance, perform Function Checks.



WARNING:

Do not use the incubator if it fails to function as described. Refer service to qualified personnel.



SHOCK HAZARD:

Make sure that the building power source is compatible with the electrical specifications shown on the right side of the incubator and the variable height adjustable pedestal stand. For proper grounding reliability, connect the power cord only to a properly marked, three-wire, hospital-grade or hospital-use receptacle. Do not use extension cords.



WARNING:

To prevent injury or damage to the variable height adjustable pedestal stand when transporting, employ a person of sufficient strength to adequately control the incubator.



CAUTION:

When using the variable height adjustable pedestal stand, always lower the incubator to its lowest position prior to transport for optimum stability.

1. Initial Actions have been performed.

Yes **No**
↓ → Go to "Initial Actions" on page 2-3.

2. Connect the pedestal stand AC power cord, and apply power:
 - a. Connect the pedestal stand power cord to an AC source.

- b. Press the **Power** switch on the pedestal stand.
- c. Press the **Power** switch on the incubator. When initially turned on, the unit performs a self-test indicated by the flashing hourglass.

All indicator lamps light, and the audible alarm is pulsed.

Yes **No**

- ↓ → If the unit fails the self-test, the alarm sounds, and one or more of the following messages appear in place of the Trend display on Display #1: **Controller Fail**, **EEPROM Fail**, or **Sensor Module Failure**. Refer the unit to service.

3. Check the **Power Failure** alarm by unplugging the pedestal stand power cord from its power source. The **Power Failure** alarm sounds, and the **Power Fail** indicator on the controller lights.

Yes **No**

- ↓ → There is no power, and the **Power Failure** alarm is not activated. The **Power** switch is not on. Press the **Power** switch.

4. Perform the following:
 - a. Connect the power cord. Make sure the power cord is fully plugged into the wall stand and incubator receptacles.
 - b. After the self-test, Display #1 appears. Set the air set temperature to 95°F (35°C). Allow the unit to operate while checking the hood/shell.
5. Check the variable height adjustable pedestal/stand if so equipped.
 - a. Turn on the main power switch.
 - b. Use your foot to press the **Up** arrow of the variable height adjustable pedestal stand, front, up/down switch (X) to raise the stand to the maximum height (see figure 2-1 on page 2-6).

Figure 2-1. Variable Height Adjustable Pedestal/Stand Up/Down Switch

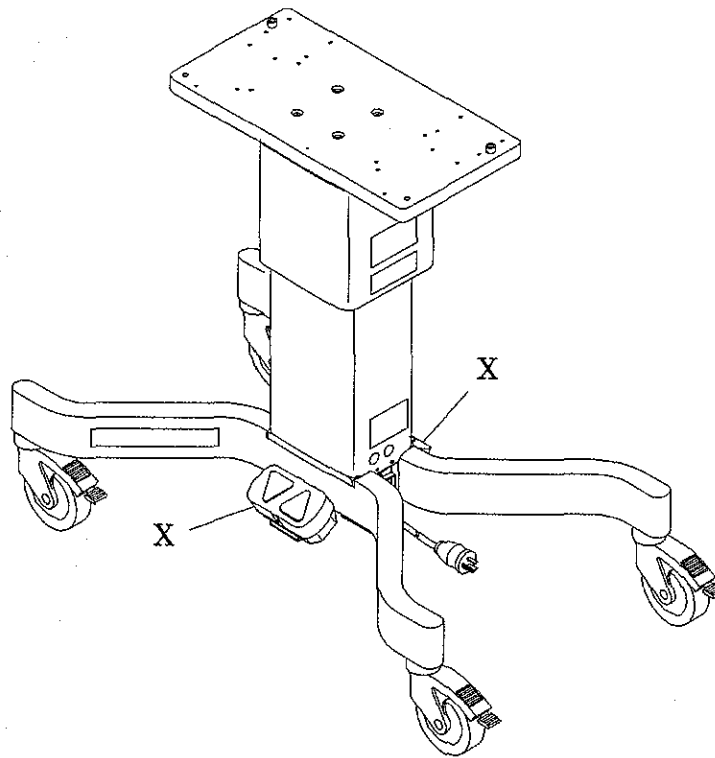

m223f072

- c. Press and hold the **Down** arrow of the variable height adjustable pedestal stand up/down switch (X) to lower the stand to the minimum height.
- d. Repeat using the rear up/down switch (X).

The stand operates smoothly and adjusts to the desired height.

Yes **No**
↓ → Go to RAP 2.2.

- 6. Check the hood (A) operation (see figure 2-2 on page 2-7).
 - a. Disconnect the weighing scale cable (B) from the sensor module (C).
 - b. Slowly tilt the hood (A) back until the hood (A) comes to rest.
 - c. Close the hood (A).
 - d. Connect the cables on the sensor module (C).
 - e. Connect the weighing scale cable (B) on the sensor module (C).

The hood operates correctly.

Yes **No**
↓ → Replace the hood.

Figure 2-2. Hood/Shell Assembly Operation

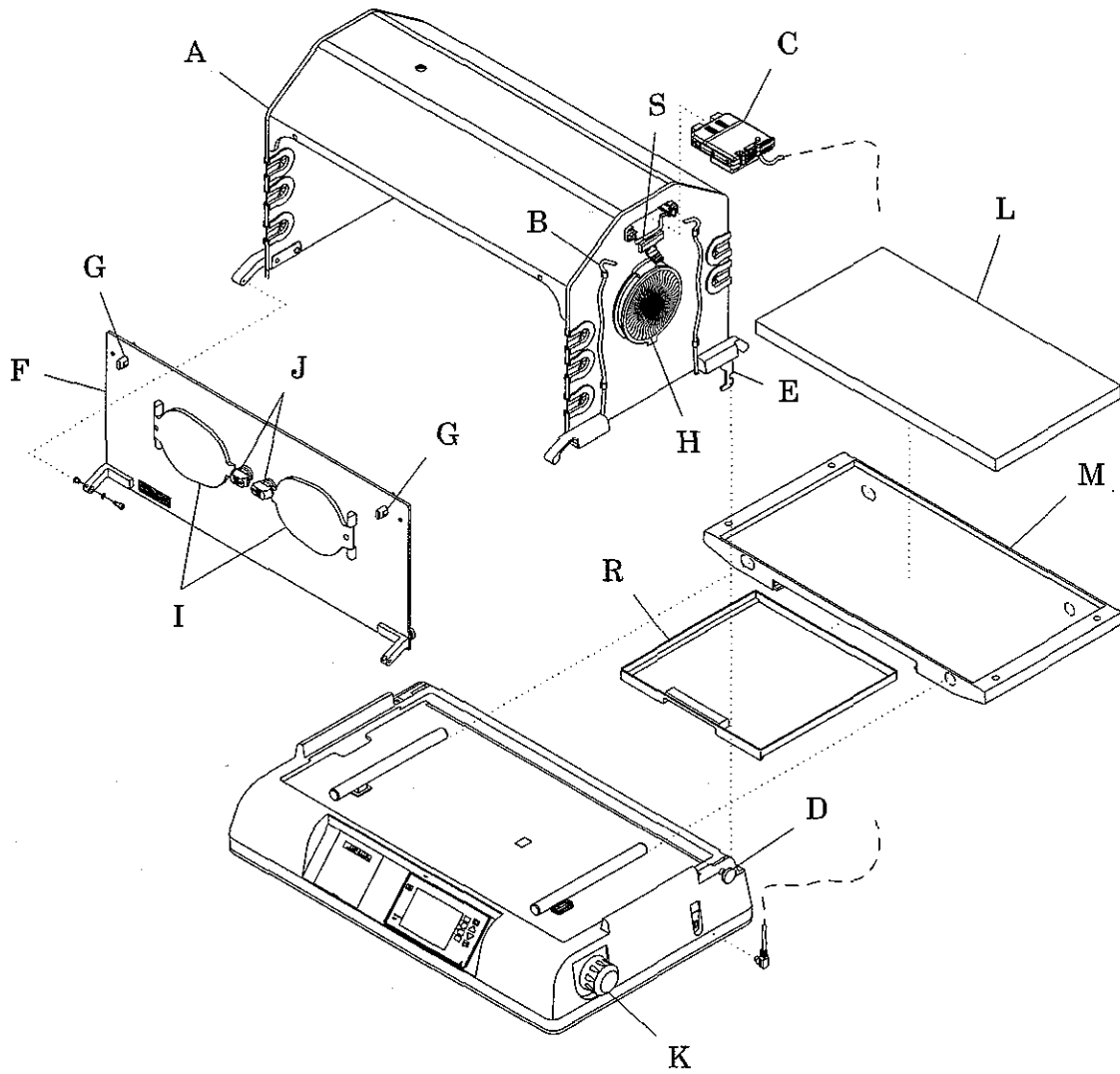

m223f038

7. For hoods (A) equipped with a self-locking mechanism, perform the following:
 - a. Disconnect the weighing scale cable (B) from the sensor module (C).
 - b. Slowly tilt the hood (A) back until the hood (A) locks in place.
 - c. Release the hood (A) by pulling on and holding the knob (D) located on the right rear hinge (E) while closing the hood (A).
 - d. Connect the weighing scale cable (B) on the sensor module (C).

The self-locking mechanism and knob (D) operate correctly.

Yes No

↓ → Replace the self-locking mechanism and knob (D).

8. Check the access panel (F).
 - a. On a "00" Series hood, slide the blue slide latches, and open the access panel (F).
 - b. On all hoods other than "00" Series, rotate the pawl latches (G), and open the access panel (F).
 - c. Pivot the access panel (F) to the full-open position (hanging straight down).
 - d. Check the rear access panel (F), if so equipped.
 - e. Close the access panel (F).

The latches (G) are properly secured to avoid accidental opening of the panel(s) (F).

Yes No

↓ → Replace the access panel (F) (refer to procedure 4.7).

9. Check the iris entry ports (H) by rotating the outer ring of the iris port (H).

The iris (H) opens and closes as rotation is continued through 360°.

Yes No

↓ → Replace the iris entry port (H) sleeve (refer to procedure 4.8).

10. Check the access door (I) latches and gaskets.

- a. Press the door release (J) of each access door (I). The access door (I) swings open.

Yes No

↓ → Replace the door release (J).

- b. Close the doors (I), and check for proper latching and quietness. The access door (I) gaskets are placed properly on the inner and outer walls.

Yes **No**
↓ → Replace the access door (I) gasket.

11. Check that the inner walls are properly latched. Open the access panel(s) (F). The front and rear inner walls are properly latched.

Yes **No**
↓ → Replace the inner wall.

12. Check the mattress (L) elevators. Rotate the right mattress tilt mechanism knob (K) counterclockwise until it stops. The right end of the mattress (L) is at a 12° angle.

Yes **No**
↓ → Replace the mattress elevator.

13. Rotate the right mattress tilt mechanism knob (K) clockwise until it stops. The mattress (L) is level.

Yes **No**
↓ → Replace the mattress elevator.

14. Turn the left mattress tilt mechanism knob (K) clockwise. The left end of the mattress (L) is at a 12° angle.

Yes **No**
↓ → Replace the mattress elevator.

15. Turn the left mattress tilt mechanism knob (K) counterclockwise. The mattress (L) is level.

Yes **No**
↓ → Replace the mattress elevator.

16. Check the mattress tray (M) operation.

- a. Slide out the mattress tray (M) to the fully-extended position.
- b. Carefully lean on the mattress tray (M) to make sure it is properly supported to provide a firm infant platform.
- c. Return the mattress (L), and close the access panel (F).

The mattress tray (M) is a firm platform for an infant.

Yes **No**
↓ → Replace the mattress tray (M).

17. Check the air intake microfilter (N) (see figure 2-3 on page 2-10).

Figure 2-3. Shell Assembly

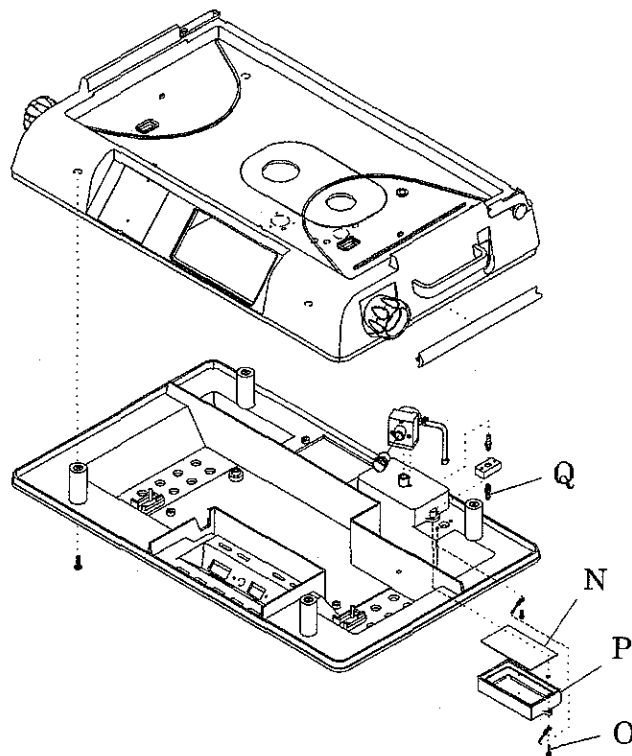

m223f039

**WARNING:**

A dirty air intake microfilter may affect oxygen concentrations and/or cause carbon dioxide build-up. Check the filter routinely, and change it at least every 3 months.

- a. Loosen the two thumbscrews (O) on the air intake filter cover (P), and remove the cover (P).
- b. Inspect the microfilter (N).

The microfilter (N) has no visible dirt.

Yes **No**

↓

→ Replace the microfilter (N) (refer to procedure 4.4).

18. Check the air/oxygen system.

- a. Introduce a carefully measured 9 lpm of oxygen into the oxygen input connector (Q).
- b. Using a calibrated oxygen analyzer, monitor the levels within the hood (A).

The levels reach the predicted level as indicated on the rear panel (F) of the incubator (9 lpm in equals 50% to 70%) (see figure 2-2 on page 2-7).

Yes **No**
↓ → Go to RAP 2.4.

19. Check the x-ray tray (R). Open the access panel (F), and withdraw the x-ray tray (R). The x-ray tray (R) operates correctly.

Yes **No**
↓ → Replace the x-ray tray (R).

20. If installed, check the sensor module lock (S).

- a. Pull the sensor module lock (S) down.
- b. Check that the sensor module (C) slides in and out of the hood (A).
- c. Push the sensor module lock (S) up.

When the sensor module lock (S) is in the up position, the sensor module (C) is locked securely.

Yes **No**
↓ → Replace the sensor module lock (S).

21. Check Air Mode. With all access openings closed, allow the incubator to warm up to the air set temperature of 95°F (35°C). It takes less than 1 hour.

Yes **No**
↓ → Go to RAP 2.1.

22. When the **Air Temperature** display has stabilized, the digital display remains within 0.5°C of the set temperature for 15 min.

Yes **No**
↓ → Go to RAP 2.1.

23. Check the air **Set Temperature** alarm.

- a. Open the access panel (F).
- b. In approximately 5 min, the alarm indicators activates, the **Low Air Temperature** message appears on the Trend display, and an alarm sounds.

Yes **No**
↓ → Go to RAP 2.1.

- c. Close the access panel (F).

24. Check Skin Mode.

- a. Connect the skin probe to skin connector #1 on the sensor module (C).

- b. Place the skin probe 4" (10 cm) above the center of the mattress.
- c. Set the skin set temperature to 95°F (35°C).
- d. When the temperature stabilizes, open the access panel (F).

In approximately 5 min, the alarm indicators activate, the **Low Skin Temperature** message appears in place of the Trend display, and the alarm sounds.

Yes **No**
↓ → Go to RAP 2.1.

NOTE:

The sensor module is equipped to accept two skin probes. However, when the second skin probe is connected to the sensor module in Skin Mode, an alarm sounds, and the message **Remove Skin 2 Probe** appears. In order to connect the second skin probe, first select Air Mode, and then the controller displays the two temperatures.

25. Check the **Connect Skin 1 Probe** alarm.

- a. Remove the skin probe #2 from the sensor module (C).
- b. Select Skin Mode.
- c. Disconnect the skin probe #1 from the sensor module (C). The alarm sounds, and the **Skin Temperature** display goes blank.
- d. The message **Connect Skin 1 Probe** appears.
- e. Press the **Silence/Reset** key. The alarm goes silent for 5 min.

Connect a skin probe. The incubator returns to normal operation.

Yes **No**
↓ → Go to RAP 2.1.

26. Check the maximum air temperature.

- a. Connect a skin probe to the sensor module (C), and select Skin Mode and a temperature of greater than 99°F (37°C).
- b. Place the skin probe sensor outside the incubator.
- c. Allow the incubator to heat.
- d. If the **Skin Temperature** alarm sounds, press the **Silence/Reset** key.

The incubator's temperature stays below 103.8°F (39.9°C) as indicated by the **Air Temperature** display.

Yes **No**
↓ → Go to RAP 2.1.

27. Check the weighing system accessory (if applicable).
- Ensure that the mattress (L) is level, i.e., not in Trendelenburg or Reverse Trendelenburg (see figure 2-2 on page 2-7).
 - If you desire a pounds/ounces display, refer to "Installation and Set-up" on page 6-20.
 - If necessary, remove any objects from the mattress (L) before pressing the **Zero** softkey.
 - Select Display 2, and press the **Weigh** softkey.
 - Press the **Zero** softkey twice in succession.

The **Weight** display reads zero, and the **Weight Sample** bar is searching.

Yes **No**
↓ → Go to RAP 2.1.

28. Place a weight of known value (less than 15 lb (7 kg)) on the mattress. The weight is displayed. When the **Weight Sample** bar stops searching (bar filled), a beep sounds and the weight is locked into the **Weight** display.

Yes **No**
↓ → Go to RAP 2.1.

29. Press the **Home** key to return to Display 2. Press the **Weigh** softkey. The display again displays the value of the weight on the mattress (L).

Yes **No**
↓ → Go to RAP 2.1.

30. Remove the weight from the mattress (L), press the **Home** softkey, and check the oxygen system accessory (if applicable).
- Place a calibrated oxygen analyzer inside the hood (A) at the center of the mattress (L).
 - On Display 1, press the **Oxygen** softkey.
 - Turn on Oxygen control.
 - Set the oxygen setpoint to 45%.

Within 5 minutes, the oxygen analyzer and the **Oxygen** display reads 45% ± 5%.

Yes **No**
↓ → The oxygen concentration level is too low. Go to RAP 2.4.

31. Within 5 minutes, the oxygen analyzer and the **Oxygen** display reads 45% ± 5%.

Yes **No**
↓ → The oxygen concentration level is too high. Go to RAP 2.5.

32. Check the humidity system accessory (if applicable).
- a. Fill the reservoir, and place the probe of a calibrated hygrometer inside the hood (A) at the center mattress (L).
 - b. Pre-warm the incubator to 95°F (35°C).
 - c. On Display 1, press the **Humidity** softkey.
 - d. Turn on the humidity. Set the humidity setpoint to 50%.
 - e. Within 30 min to 60 min, the hygrometer and **Humidity** display reads 50% ± 6%.

Yes **No**
↓ → Go to RAP 2.1.

33. Go to “Final Actions” on page 2-14.

Final Actions

1. Complete the required preventive maintenance procedures. See “Preventive Maintenance Checklist” on page 6-8.
2. Complete all required administrative tasks.

Alarms

High and Low Air and Skin Temperature Alarms

The high and low air or skin temperature alarms are actuated if the skin or air temperature fluctuates from the set temperature as follows:

- Skin temperature— $\pm 1.0^{\circ}\text{C}$
- Air temperature— $+1.5^{\circ}\text{C}$, -2.5°C

NOTE:

The skin temperature limits may also be set to $\pm 0.5^{\circ}\text{C}$. Refer to “Installation and Set-up” on page 6-20.

A temperature below the air or skin set temperature is indicated by Low Air Temperature or Low Skin Temperature in the message center, an audible alarm, flashing indicators, and a low temperature reading. A temperature above the air or skin set temperature is indicated by High Air Temperature or High Skin Temperature in the message center, an audible tone, flashing indicators, and a high temperature reading.

The high and low air or skin temperature alarms are self-resetting; that is, if the alarm condition is corrected, the alarm is automatically silenced and the visual alarm indicators are turned off. The audible portion of the high and low air or skin temperature alarms can be silenced by pressing the **Silence/Reset** key; the activation of other audible and visual alarms are not affected by use of the 15-min audible alarm silence. When the alarm is silenced, the alarm indicators remain on until the alarm condition is corrected. If the alarm condition is not corrected within 15 min, the audible alarm is activated.

In addition, if it is desired to change the air or skin set temperature (either high or low) after the incubator is in operation, the high temperature and low temperature alarms are automatically silenced for a specific amount of time after the operator raises or lowers the air or skin set temperature from the current temperature.

As a general rule, the greater the change from the current incubator temperature, the longer the alarm remains silent. If the incubator fails to reach the new set temperature after the specified time, the alarm sounds.

Alternately, before changing the current air or skin set temperature, the operator may press the **Silence/Reset** key to place the unit in Procedural Silence Mode. In Procedural Silence Mode, the low temperature alarm is

silenced for up to 15 min. Procedural Silence Mode is terminated if a **High Temperature, Airflow, or Probe** alarm occurs.

Alarm Messages

The alarm and system prompt messages that replace the Trend Display or the oxygen and humidity displays during an alarm condition or procedure are presented in table 2-1 on page 2-16, table 2-2 on page 2-18, table 2-3 on page 2-20, table 2-4 on page 2-21, table 2-5 on page 2-21, and table 2-6 on page 2-22.

In the event that two or more alarms occur simultaneously, or one after the other, the messages that describe the alarms will be presented in sequence. A total of five messages can be posted.

For an explanation of system alarms, refer to table 2-1 on page 2-16.

Table 2-1. System Alarms

Alarm	Description
Power Failure	A flashing alarm indicator appears with a continuous audible alarm to indicate that primary power to the incubator fails, or the power cord is unplugged from its power source. To silence this alarm for 15 min, press the Silence/Reset key. Plug the power cord into an appropriate power source.
Motor Failed	A flashing alarm indicator appears with a continuous audible alarm to indicate a motor malfunction. Turn the incubator off, and remove it from service (refer to procedure 4.6).
EEPROM failed	A flashing alarm indicator appears with a continuous audible alarm to indicate an internal malfunction. Turn the incubator off, and remove it from service.
Heater failure 1 and 2	A flashing alarm indicator appears with a continuous audible alarm to indicate a heater malfunction. Turn the incubator off, and remove it from service.
Controller failure 1 through 14	A flashing alarm indicator appears with a continuous audible alarm to indicate an internal malfunction. Turn the incubator off, and remove it from service (refer to procedure 4.1).

Alarm	Description
Key stuck	An audible alarm and flashing alarm indicators appear to indicate a controller key malfunction (refer to procedure 4.1).
Air probe failed	Air probe malfunction.
Low airflow	A flashing alarm indicator appears with a continuous audible alarm to indicate a lack of air circulation within the incubator. The fan motor has failed. Replace the fan motor (refer to procedure 4.6).
Sensor module failure	An audible alarm and flashing alarm indicators appear to indicate that the sensor module malfunctions or is not connected to the incubator (refer to procedure 4.2).
Sensor out of position	The sensor module is not in the correct position to perform calibration or continue operation (refer to procedure 4.2).
Alarm indicator	A flashing alarm indicator appears with an audible alarm to indicate that the incubator has experienced an alarm condition.
Sensor disconnected	An audible alarm and flashing alarm indicators appear to indicate that the sensor module has experienced an communications failure. Turn the incubator off, and remove it from service (refer to procedure 4.2).

For an explanation of temperature alarms, refer to table 2-2 on page 2-18.

Table 2-2. Temperature Alarms

Alarm	Description
Low air temperature	This message appears with an audible alarm and flashing alarm indicators to indicate that the incubator air temperature is 2.5°C below the air set temperature. To silence this alarm for 15 min, press the Silence/Reset key. Go to RAP 2.3.
High air temperature	This message appears with an audible alarm and flashing alarm indicators to indicate that the incubator air temperature is 1.5°C above the air set temperature. Additionally, the heater is turned off. To silence this alarm for 15 min, press the Silence/Reset key.
Skin mode disabled	This message appears with an audible alarm and flashing alarm indicators to indicate that Skin Mode has been disabled. Activate Skin Mode.
Low skin temperature	This message appears with an audible alarm and flashing alarm indicators to indicate that the baby's skin temperature being monitored by skin temperature probe #1 is 1°C (or 0.5°C) below the skin set temperature. To silence this alarm for 15 min, press the Silence/Reset key. Go to RAP 2.3.
High skin temperature High skin 1 temperature	This message appears with an audible alarm and flashing alarm indicators to indicate that the baby's skin temperature being monitored by skin temperature probe #1 is 1°C (or 0.5°C) above the skin set temperature. To silence this alarm for 15 min, press the Silence/Reset key.
High temperature cut out	This message appears with an audible alarm and flashing alarm indicators to indicate that incubator air temperature has reached approximately 103.1°F (39.5°C) (American and Canadian incubators only). All other incubators will alarm at 99.5°F (37.5°C) for set temperatures < 99°F (37°C) and 103.1°F (39.5°C) for set temperatures > 99°F (37°C).

Alarm	Description
Remove skin 2 probe	<p>This message appears with an audible alarm and flashing alarm indicators to indicate that a second skin probe is connected to the sensor module when operating in Skin Mode. To connect a second skin probe, select Air Mode first. To silence this alarm, remove the skin probe.</p> <p>This alarm also appears with an audible alarm and flashing alarm indicators to indicate that a second skin probe is connected to the sensor module when in Air Mode and an attempt has been made to enter Skin Mode. To enter Skin Mode, must remove Skin Probe #2, and press the Silence/Reset key.</p>
Skin 1 probe fail	<p>This message appears with an audible alarm and flashing alarm indicators to indicate that skin temperature probe 1 has malfunctioned. To silence this alarm for 5 min, press the Silence/Reset key.</p>
Skin probe disconnect	<p>This message appears with an audible alarm and flashing alarm indicators to indicate that skin temperature probe 1 has been disconnected from the sensor module when in Air Mode and an attempt has been made to enter Skin Mode.</p>
Connect skin 1 probe	<p>This message appears with an audible alarm and flashing alarm indicators to indicate that skin temperature probe 1 is disconnected from the sensor module while sw Skin Mode.</p>
Skin Mode disabled	<p>This message appears with an audible alarm and flashing alarm indicators to indicate that Skin Mode has been disabled. Enable Skin Mode.</p>

For an explanation of oxygen alarms, refer to table 2-3 on page 2-20.

Table 2-3. Oxygen Alarms

Alarm	Description
Low oxygen %	This message is displayed along with an audible alarm and flashing alarm indicators to indicate that the oxygen concentration within the hood environment has fallen below the oxygen set point. This alarm may be silenced for 4 min by pressing the Silence/Reset key. Go to RAP 2.4.
High oxygen %	This message is displayed along with an audible alarm and flashing alarm indicators to indicate that the oxygen concentration within the hood environment has risen above the oxygen set point. This alarm may be silenced for 4 min by pressing the Silence/Reset key. Go to RAP 2.5.
Oxygen calibration required	This message is displayed along with an audible alarm and flashing alarm indicators to indicate that the oxygen control system requires calibration. This alarm may be silenced for 5 min by pressing the Silence/Reset key. Calibrate the oxygen control system (refer to procedure 6.2).
Oxygen cell different	This message is displayed along with an audible alarm and flashing alarm indicators to indicate that the oxygen cell readings differ by greater than 3%. This condition can often be fixed by calibrating the oxygen control system (refer to procedure 6.2).
Oxygen solenoid fail	This message informs the user that the oxygen solenoid has failed.

For an explanation of humidity alarms, refer to table 2-4 on page 2-21.

Table 2-4. Humidity Alarms

Alarm	Description
Low humidity	This message appears with an audible alarm and flashing alarm indicator to indicate that the humidity tray is empty. Silence this alarm for 5 min by pressing the Silence/Reset key. Refill the reservoir.
Humidity heater failure	This message informs the user that the humidity system has malfunctioned.

For an explanation of weighing scale alarms, refer to table 2-5 on page 2-21.

Table 2-5. Weighing Scale Alarms

Alarm	Description
Too much weight	This message appears with an audible alarm and flashing alarm indicators to indicate that the weight on the mattress is in excess of 15 lb (7 kg). When zeroing, this message appears if a weight in excess of 2 lb (1 kg) or, with software version 2.5 or higher, 7.7 lb (3.5 kg), is on the mattress. Silence this alarm for 5 min by pressing the Silence/Reset key. Remove the excess weight.
Scale disconnected	This message appears if the cable between the scale and the sensor module is disconnected. Connect the cable between the scale and the sensor module.
Clear mattress	This message appears if extraneous objects are on the mattress. Remove any extraneous objects from the mattress.

For an explanation of system prompt messages, refer to table 2-6 on page 2-22.

Table 2-6. System Prompt Messages

Prompt Message	Description
Power-On Test in Progress	This message indicates that the controller is performing the power-up test.
21% Cal	This message indicates that the oxygen control system is performing the 21% calibration procedure.
100% Cal	This message indicates that the oxygen control system is performing the 100% calibration procedure.
Cal Pass	This message indicates that the oxygen control system is successfully calibrated.
Cal Fail	This message indicates that the oxygen control system has failed to calibrate. Repeat the calibration procedure (refer to procedure 6.2). If the system fails to calibrate a second time, refer it to qualified service personnel.
Procedural Silence	This message indicates that the 5 min Procedural Silence is active. During this time, low skin and air temperature alarms are automatically silenced for 15 min. The Low Oxygen % alarm automatically silences for 4 min.
Slide Out Sensor	This message informs the user to withdraw the sensor module from the hood.
Slide In Sensor	This message informs the user to return the sensor module inside the hood.
Not Installed	This message informs the user that the humidity or oxygen systems are not activated or installed. Install the humidity system according to "Humidity System ("00" and "01" Series Models Only)" on page 7-11 or "Humidity System ("02" Series Model Only)" on page 7-15 and/or the oxygen system according to "Oxygen System" on page 7-6.

For an explanation of **Silence/Reset** key functions, refer to table 2-7 on page 2-23.

Table 2-7. Silence/Reset Key Functions

Alarm	Silence/Reset Key Function
Low air/skin temperature	Silence the alarm for a period of 15 min.
High air/skin temperature	Silence the alarm for a period of 15 min.
Humidity low	Silence the alarm for a period of 15 min.
Power failure	Silence the alarm for a period of 15 min.
Skin 1 probe failure	Silence the alarm for a period of 5 min.
Skin probe disconnect	Silence the alarm for a period of 5 min.
High temperature cut out	Silence the alarm for a period of 5 min.
Oxygen high %	Silence the alarm for a period of 4 min.
Oxygen low %	Silence the alarm for a period of 4 min.
Oxygen calibration required	Silence the alarm for a period of 4 min.
Oxygen cell different	Silence the alarm for a period of 4 min.
High temperature cut out	Resets the alarm (cancels the alarm if the alarm condition no longer exists).
Sensor module failure	Resets the alarm (cancels the alarm if the alarm condition no longer exists).
Power fail	Resets the alarm (cancels the alarm if the alarm condition no longer exists).

System Failure Messages

In the event of a system failure, an appropriate message appears on the controller screen. The system failure messages, along with their possible causes, are presented below

Table 2-8. System Failure Messages

Message	Cause
Controller failure 1	EEPROM circuitry failure
Controller failure 3	Ambient air probe failure
Controller failure 4	Controller cooling fan failure
Controller failure 5	Display test failure
Controller failure 6	External serial port loop-back test failure
Controller failure 7	Power supply voltage failure
Controller failure 8	RAM test failure
Controller failure 9	Real time clock failure
Controller failure 10	Watchdog timer failure
Controller failure 11	Relay test failure
Controller failure 13	Heater circuit failure detected after all relays are off for 5 s or currents are above the maximum limits during power up
Controller failure 14	Low heater current detected
Heater failed 1	Heater thermocouple voltage exceeds ± 40 mV
Heater failed 2	Heater thermocouple wires are open or shorted
Humidity heater failure	Humidity heater draws too much current
Motor failed	With software version 2.06, the fan motor speed exceeds ± 450 rpm. With previous software versions, the fan motor speed exceeds ± 200 rpm
Sensor disconnect	Communications failure between sensor module and controller
Sensor out of position	Sensor module not in hood or calibration position
Stuck key	Stuck key detected
Check settings	Non-volatile memory (NVM) integrity test failure

2.1 Diagnostic Menus

To aid in troubleshooting, the Isolette® Infant Incubator has a series of diagnostic menus. To access the diagnostic menus, refer to “Entering the Diagnostic Menus” on page 2-25.

Entering the Diagnostic Menus

1. Enter the set-up menu.
2. Turn off the controller power switch.
3. Press the **Silence/Reset** key (A) while simultaneously turning on the controller power switch. The Diagnostic Menu appears (see figure 2-4 on page 2-25).

Figure 2-4. Diagnostic Menu

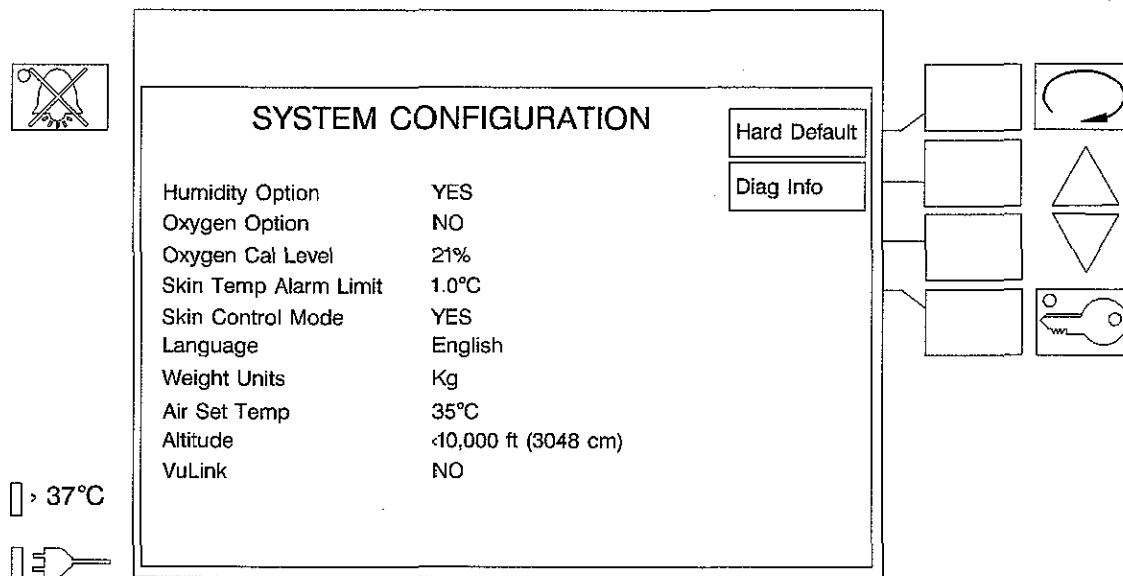

m223f107

4. After viewing the current settings, perform one of the following:
 - a. To return the menu to the original settings, shown in table 2-9 on page 2-26, press the Hard Default key.

Table 2-9. System Configuration Factory Default Settings

Feature	Setting
Temperature control mode	Air mode
Air set temperature	95.0°F (35.0°C)
Skin set temperature	97.7°F (36.5°C)
Humidity control mode	OFF
Humidity set value	50% RH
Oxygen control mode	OFF
Oxygen calibration level	21%
Temperature units	°C
Weight units	kg
Trend	Air, 2 hours
Language	English
Altitude	< 10000' (304800 cm)

- b. To call up the Diagnostic Information menu, press the Diagnostic Information key. Go to "Diagnostic Information Menu" on page 2-27.
- c. Enter the desired system configuration settings and return to Main Display 1, press the **Silence/Reset** key.

Diagnostic Information Menu

Figure 2-5. Diagnostic Information Menu

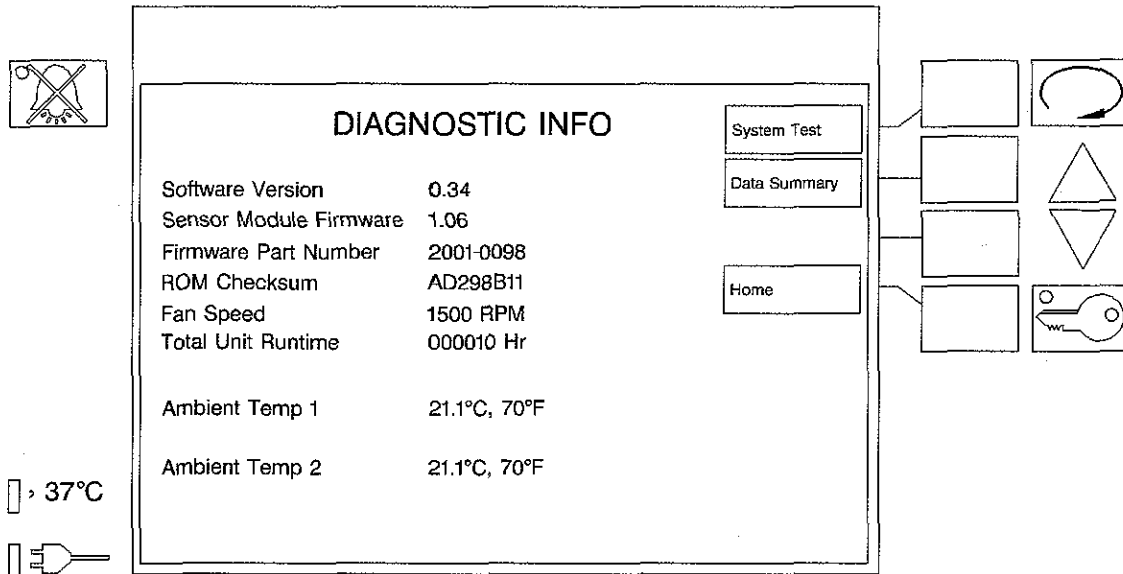

m223f108

After viewing the current diagnostic information, perform one of the following:

- To call up the System Test screen, press the **System Test** key. Go to "System Test Menu" on page 2-28.
- To call up the Data Summary screen, press the **Data Summary** key.
- To return to the Main Operating Display 1, press the **Home** key.

System Test Menu

Figure 2-6. System Test Menu (1 of 3)

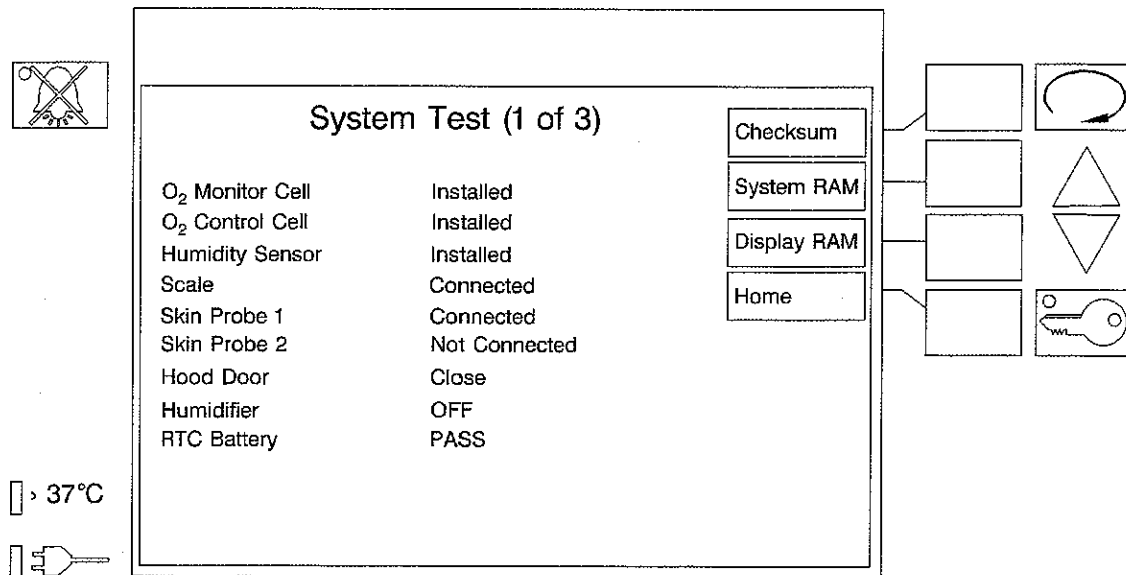

m223f109

1. After viewing the current system test results, perform one of the following:
 - a. To check the system checksum, press the **Checksum** key.
 - b. To check the system RAM, press the **System RAM** key.
 - c. To check the display RAM, press the **Display RAM** key.
 - d. To call up the System Test screen (2 of 3), press the **Display Selection** key. Go to step a.
 - e. To return to the Diagnostic menu, press the **Home** key. Go to "Entering the Diagnostic Menus" on page 2-25.

Figure 2-7. System Test Menu (2 of 3)

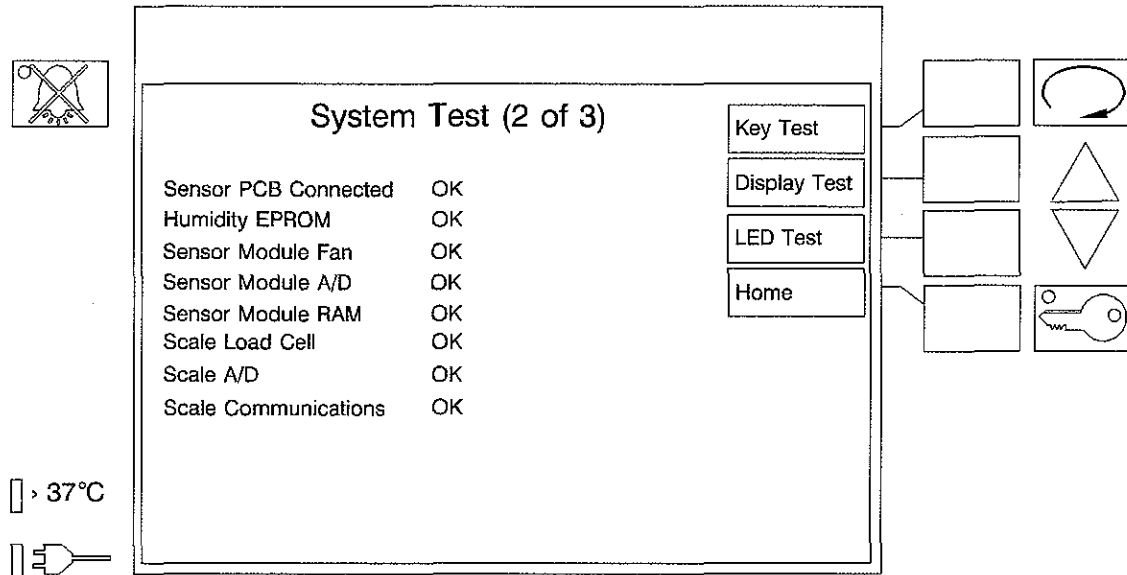

m223f110

2. Perform one of the following:
 - a. To call up the Check Key check display, press the **Key Test** key. Go to “Key Check Display” on page 2-31.
 - a. To light all segments of the display, press the **Display Test** key.
 - a. To initiate the LED test, press the **LED Test** key. All LEDs will light in succession.
 - a. To call up the System Test screen (3 of 3), press the **Display Selection** key. Go to step a.
 - a. To return to the Diagnostic menu, press the **Home** key. Go to “Entering the Diagnostic Menus” on page 2-25.

Figure 2-8. System Test Menu (3 of 3)

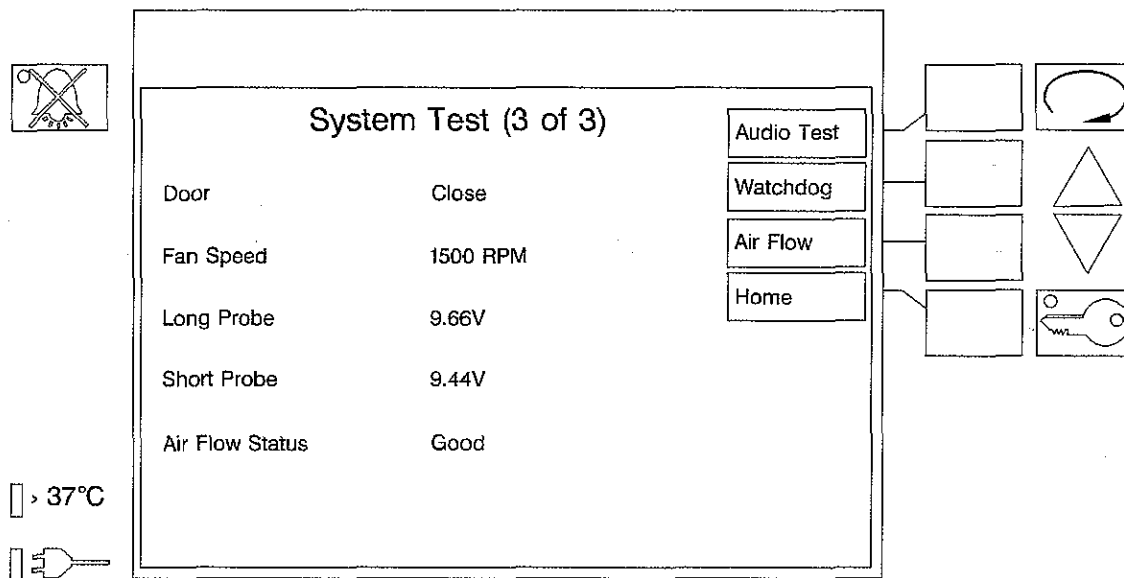

m223f111

3. Perform one of the following:
 - a. To initiate the audio test, press the **Audio Test** key.
 - b. To test the watchdog, press the **Watchdog** key.
 - c. To test the airflow, press the **Airflow** key.
 - d. To call up the System Test screen (1 of 3), press the **Display Selection** key. Go to step a.

Key Check Display

Figure 2-9. Key Check Display

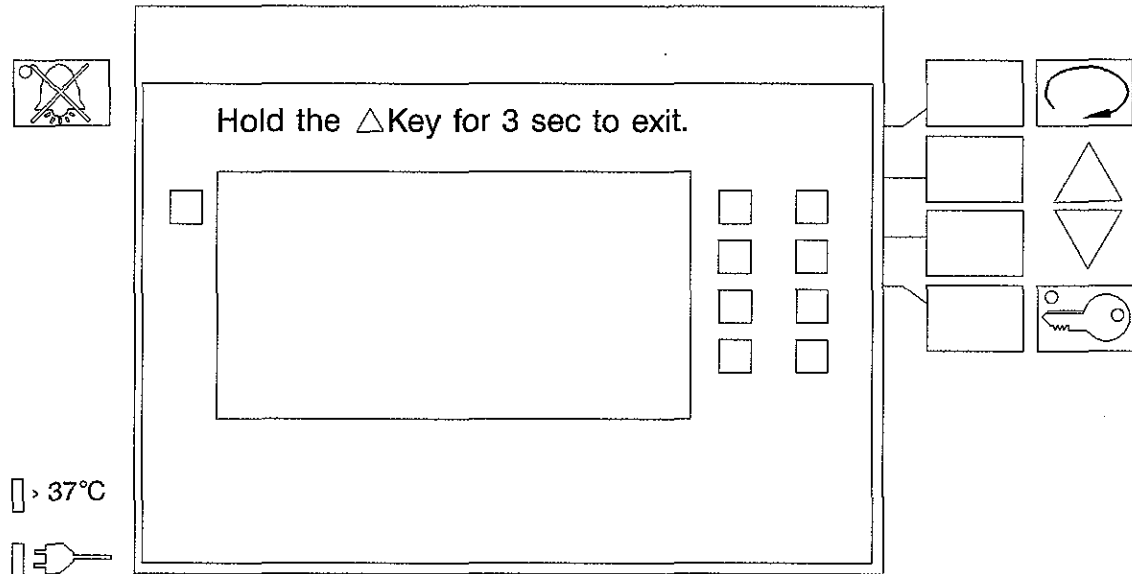

m223f112

1. Press each key in succession. If the key is functional, the appropriate box lights.
2. To exit, press the Up arrow key for 3 s.

Data Summary Menu

Figure 2-10. Data Summary Screen (1 of 2)

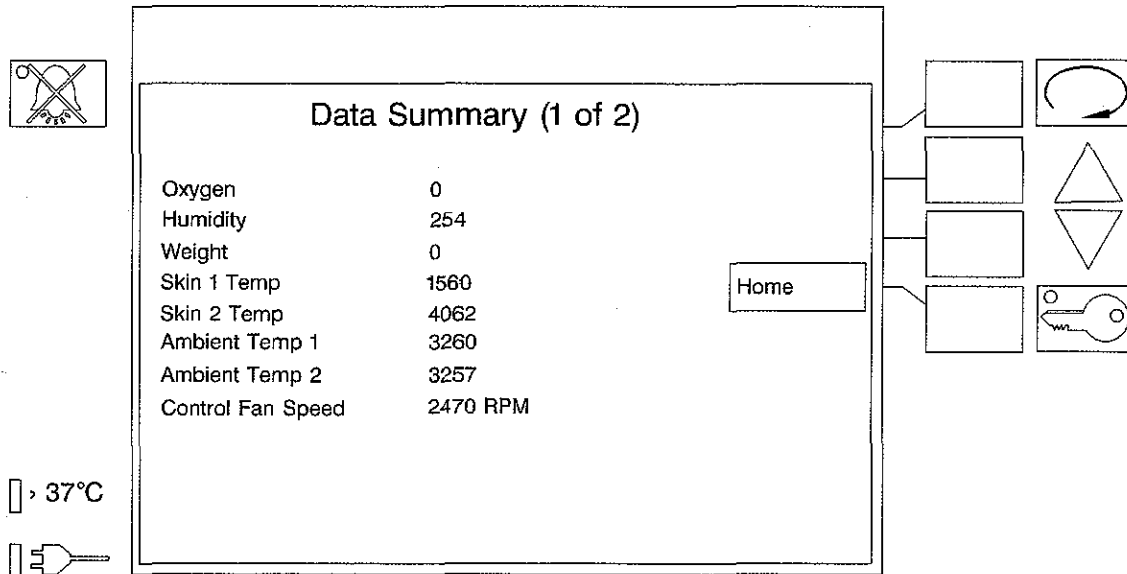

m223f113

1. To return to the Diagnostic menu, press the **Home** key. Go to “Entering the Diagnostic Menus” on page 2-25.
2. To call up the Data Summary screen (2 of 2), press the **Display Selection** key. Go to step 3.

Figure 2-11. Data Summary Screen (2 of 2)

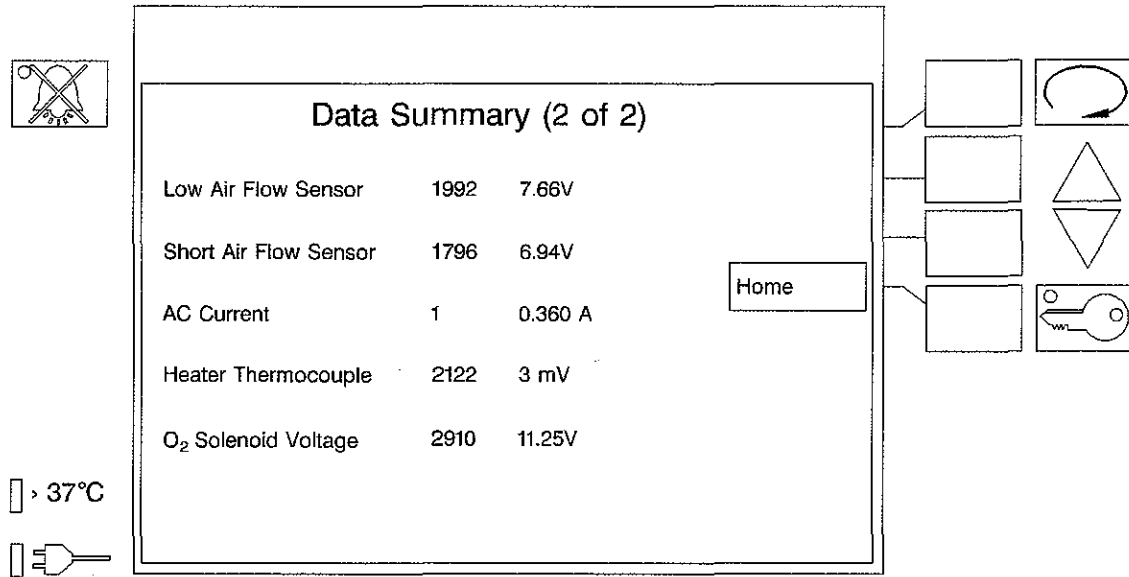

m223f114

3. To return to the Diagnostic menu, press the **Home** key. Go to "Entering the Diagnostic Menus" on page 2-25.
4. To call up the Data Summary screen (1 of 2), press the **Display Selection** key. Go to step 1.

2.2 Variable Height Adjustable Pedestal/Stand Will Not Move Up or Down

1. Check the variable height adjustable pedestal stand.
 - a. Turn on the main power switch (A) (see figure 2-1 on page 2-6).

Figure 2-12. Variable Height Adjustable Pedestal/Stand

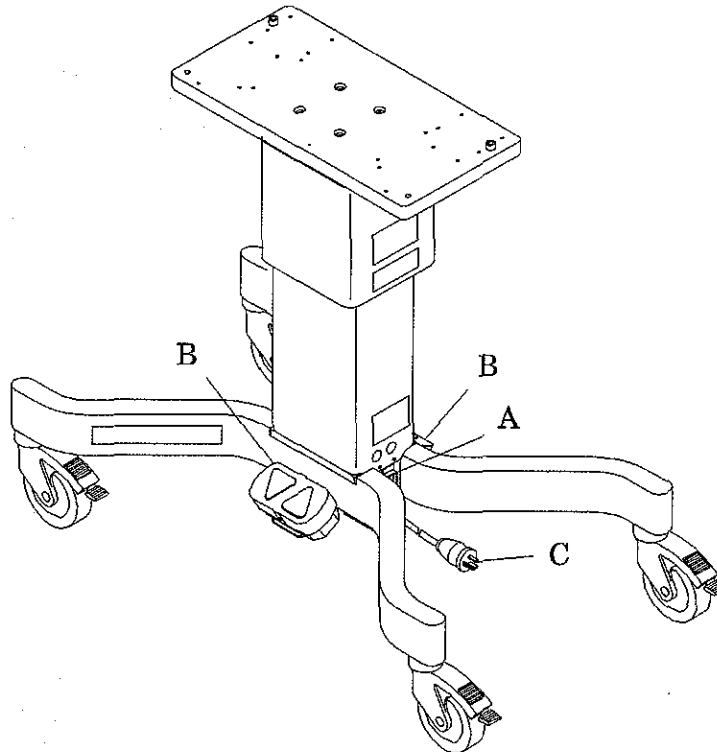

m223f073

- b. Use your foot to press the **Up** arrow of the up/down switch (B) to raise the stand to the maximum height.
- c. Press and hold the **Down** arrow of the up/down switch (B) to lower the stand to the minimum height.
- d. Repeat using the rear up/down switch (B).

The variable height adjustable pedestal/stand operates smoothly and adjusts to the desired height.

Yes **No**
↓ → Go to step 3.

2. Go to “Final Actions” on page 2-14.
3. Inspect the main power switch (A).

The main power switch (A) is ON.

Yes **No**

↓ → Turn on the main power switch (A). If this solves the problem, go to “Final Actions” on page 2-14. Otherwise, go to step 4.

4. Inspect the power cord (C).

The unit is plugged into an appropriate power source.

Yes **No**

↓ → Plug the unit into an appropriate power source. If this solves the problem, go to “Final Actions” on page 2-14. Otherwise, call Hill-Rom Technical Support at (800) 445-3720 for assistance

5. Call Hill-Rom Technical Support at (800) 445-3720 for assistance.

2.3 Low Set Temperature Alarm Activated

1. Check all access doors (A) and iris entry ports (B) (see figure 2-13 on page 2-36).

Figure 2-13. Access Doors and Iris Entry Ports

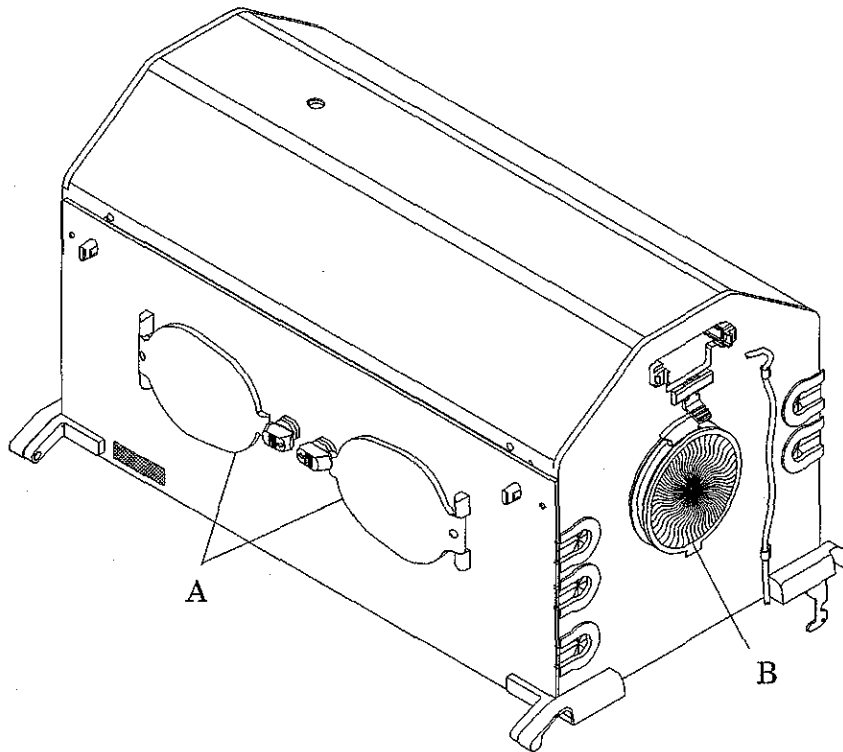

m223f043

All access doors (A) and iris entry ports (B) are closed.

Yes **No**

↓ → Close all access doors (A) and iris entry ports (B). If this solves the problem, go to “Final Actions” on page 2-14. Otherwise, go to step 2.

2. Check the unit’s mode of operation.

The unit is in Skin Mode.

Yes **No**

↓ → Call Hill-Rom Technical Support at (800) 445-3720 for assistance.

3. Check the skin probe.

The skin probe is properly secured to the infant’s skin.

Yes	No
↓	→ Properly secure the skin probe to the infant's skin. If this solves the problem, go to "Final Actions" on page 2-14. Otherwise, call Hill-Rom Technical Support at (800) 445-3720 for assistance.

4. Call Hill-Rom Technical Support at (800) 445-3720 for assistance.

2.4 Oxygen Concentration is Low

1. The oxygen source is connected to the incubator.

Yes No



→ Connect the oxygen to the incubator. If this solves the problem, go to “Final Actions” on page 2-14. Otherwise, go to step 2.

2. Check all access doors (A) and iris entry ports (B) (see figure 2-14 on page 2-38).

Figure 2-14. Access Doors and Iris Entry Ports

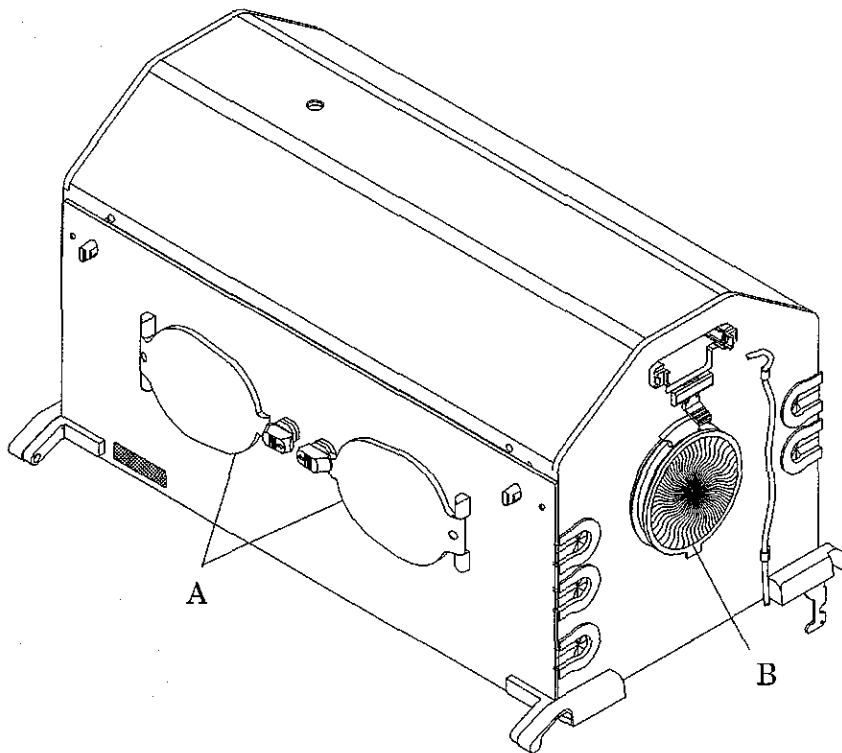

m223f043

All access doors (A) and iris entry ports (B) are closed.

Yes No



→ Close all access doors (A) and iris entry ports (B). If this solves the problem, go to “Final Actions” on page 2-14. Otherwise, go to step 3.

3. Check all iris entry port (B) sleeves.

All iris entry port (B) sleeves are properly installed.

Yes **No**
↓ → Properly install the iris entry port (B) sleeve (refer to procedure 4.8). If this solves the problem, go to “Final Actions” on page 2-14. Otherwise, go to step 4.

4. Check the tubing access ports.

The tubing access ports are properly installed.

Yes **No**
↓ → Properly install the tubing access ports.

5. Check the filter cover (C) (see figure 2-15 on page 2-39).

Figure 2-15. Filter and Filter Cover

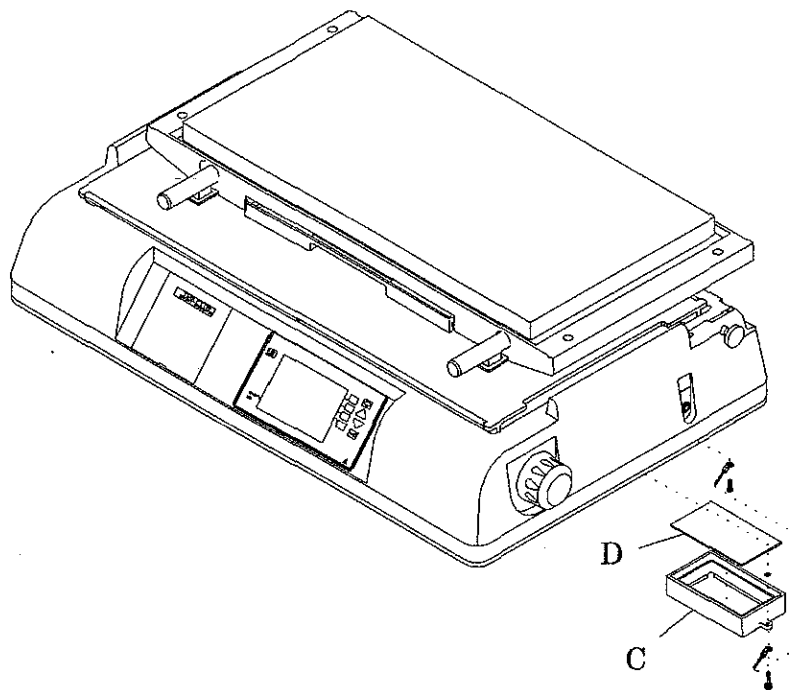

m223f044

The filter cover (C) is properly secured.

Yes **No**
↓ → Secure the filter cover (C).

6. Check the filter (D).

A filter (D) is installed.

2.4 Oxygen Concentration is Low

Chapter 2: Troubleshooting Procedures

Yes **No**

↓

→ Install a filter (D) (refer to procedure 4.4). If this solves the problem, go to “Final Actions” on page 2-14. Otherwise, call Hill-Rom Technical Support at (800) 445-3720 for assistance.

7. Call Hill-Rom Technical Support at (800) 445-3720 for assistance.

2.5 Oxygen Concentration is High

1. Check the air intake microfilter (A) (see figure 2-16 on page 2-41).

Figure 2-16. Air Intake Microfilter and Fan Impeller

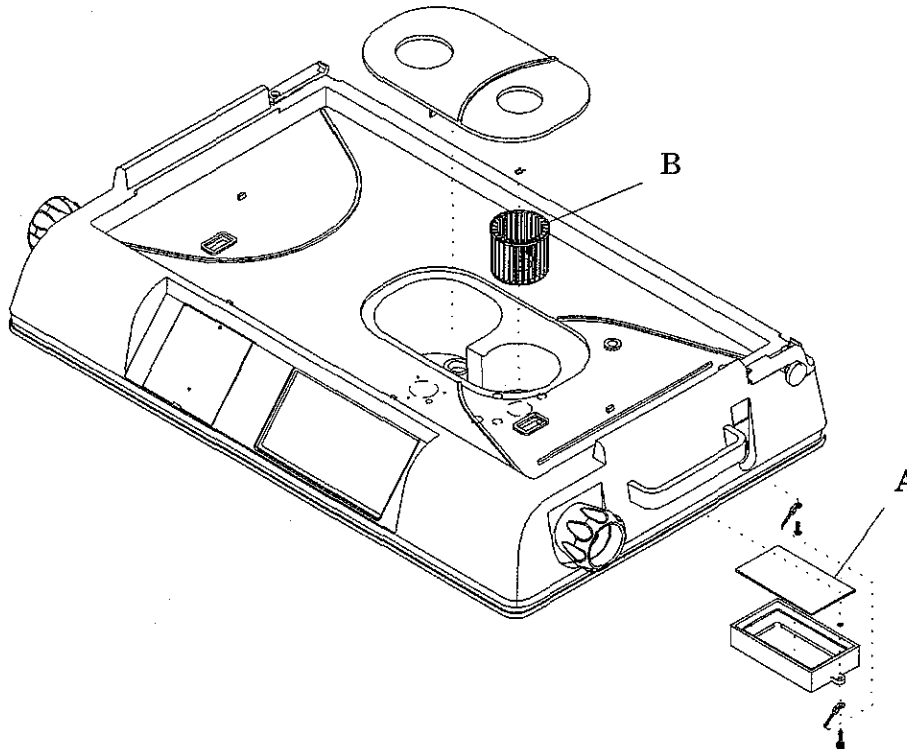

m223f045

The air intake microfilter (A) is clean.

Yes **No**



→ Replace the air intake microfilter (A) (refer to procedure 4.4). If this solves the problem, go to “Final Actions” on page 2-14. Otherwise, go to step 2.

2. Check the fan impeller (B).

The fan impeller (B) is clean.

Yes **No**



→ Clean the fan impeller (B). If necessary, replace the fan impeller (B). If this solves the problem, go to “Final Actions” on page 2-14. Otherwise, call Hill-Rom Technical Support at (800) 445-3720 for assistance.

3. Call Hill-Rom Technical Support at (800) 445-3720 for assistance.

NOTES:

Chapter 3

Theory of Operation

Chapter Contents

Controller Assembly	3 - 3
Variable Height Adjustable Pedestal/Stand Assembly	3 - 7
Hood/Shell Assembly	3 - 8
Theory of Operation	3 - 12
Electrical System	3 - 12
Sensor Module	3 - 12
Controller	3 - 16
Impeller Movement Detector (IMD) P.C. Board	3 - 17
Fan Motor	3 - 18
Heater Power	3 - 18
Humidity Heater Power	3 - 18
Air System	3 - 22
Overall Functional Description	3 - 22
Air Mode	3 - 24
Skin Mode	3 - 24
Oxygen Control	3 - 25
Humidity Control Valve	3 - 25
Hardware	3 - 25
Weighing Mode	3 - 25
Trend Displays	3 - 26
Interface Connections	3 - 26
RS-232 Serial Port Protocol	3 - 27

NOTES:

Controller Assembly

Figure 3-1. Controller Assembly Block Diagram

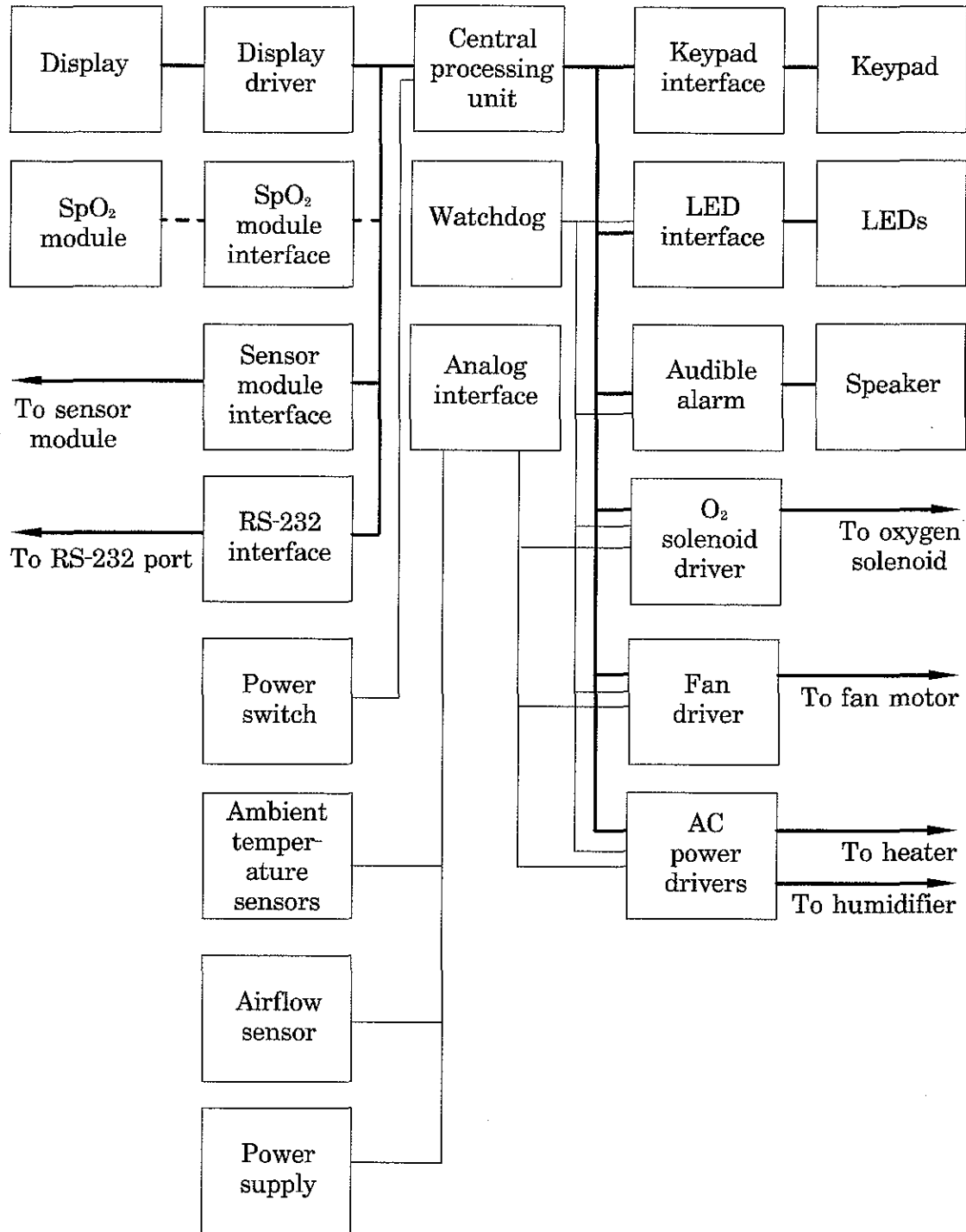

3

m223f042

Figure 3-2. Controller Power Supply Schematic Diagram

Refer to fold-out FO 3-1 at the rear of this manual.

Figure 3-3. Interface P.C. Board Schematic Diagram

Refer to fold-out FO 3-2 at the rear of this manual.

Figure 3-4. Central Processing Unit P.C. Board Schematic Diagram

Refer to fold-out FO 3-3 at the rear of this manual.

Variable Height Adjustable Pedestal/Stand Assembly

Figure 3-5. Variable Height Adjustable Pedestal/Stand Assembly Wiring Diagram

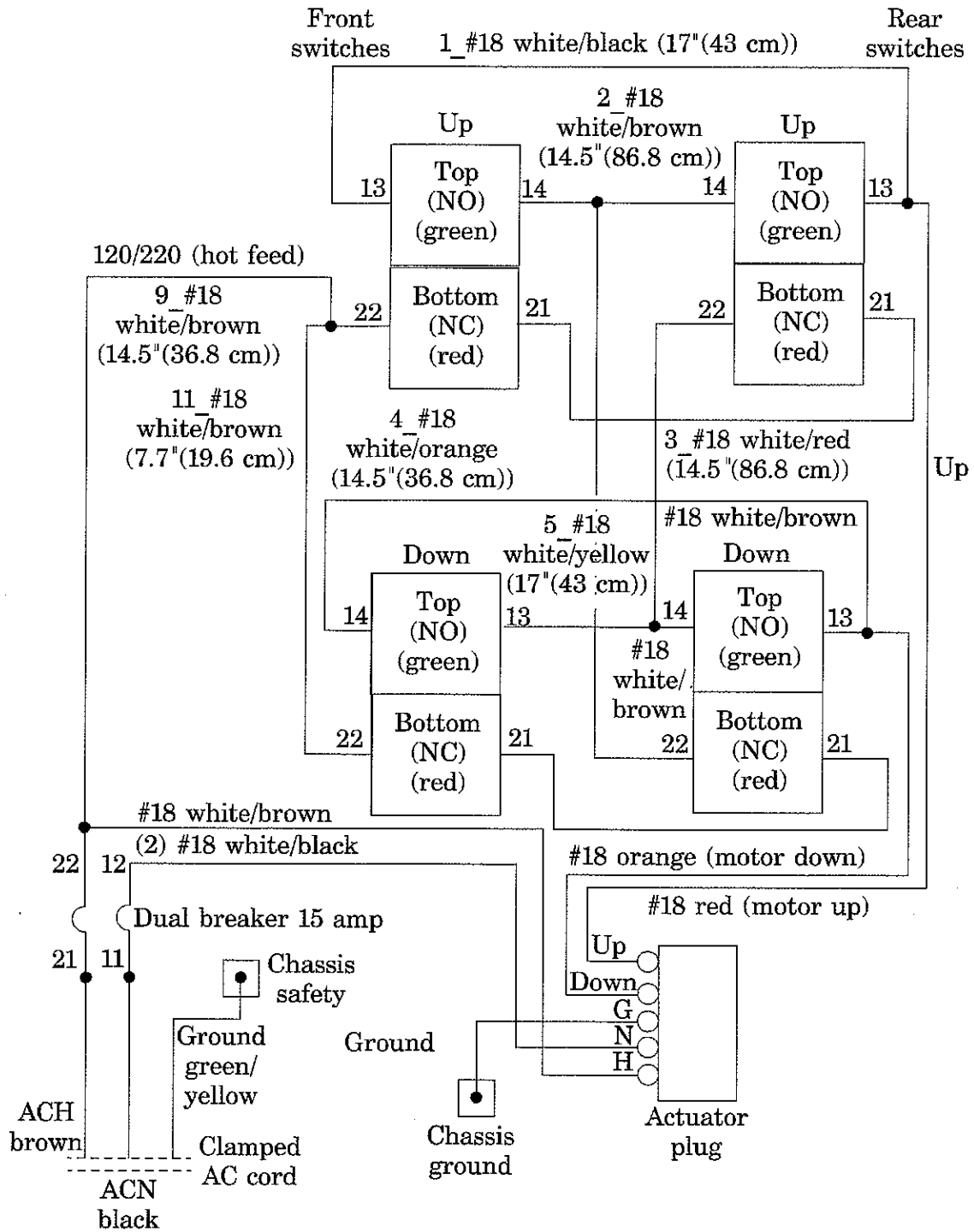

m223f104

Hood/Shell Assembly

Figure 3-6. Sensor Module Functional Block Diagram

Refer to fold-out FO 3-4 at the rear of this manual.

Figure 3-7. Sensor Module P.C. Board Schematic Diagram

Refer to fold-out FO 3-5 at the rear of this manual.

Figure 3-8. Scale P.C. Board Schematic Diagram

Refer to fold-out FO 3-6 at the rear of this manual.

Figure 3-9. Impeller Movement Detector P.C. Board Schematic Diagram

Refer to fold-out FO 3-7 at the rear of this manual.

Theory of Operation

Electrical System

Sensor Module

The sensor module P.C. board provides the interface from the patient and incubator requirements that the infant incubator must support. The module reads and processes the following parameters: temperature, oxygen, humidity, and weight information collected from external sensors and cables. This information is periodically updated and is transmitted to the main controller upon request.

The sensor module P.C. board does **not** require manual calibration. Calibration is performed automatically and periodically during normal operation. To provide safe monitoring and control, both the temperature information and oxygen information have redundant circuitry to prevent single-fault failures.

All signals are transmitted through serial data communication.

The sensor module is connected to a sensor P.C. board which has some of the parameters required for the system: air temperature, oxygen, humidity, and fan operation.

Power Supply

Power to the sensor module P.C. board is provided through connector J4, providing $\pm 12V$ AC for use in this system. Voltages are regulated by U21, U19 and U15, providing +5V, digital +5V and analog -5V, respectively. U20 provides a precision +5V source to be used in analog signal conversions.

Sensor Position Detection

Hall effect sensors are used to sense magnets in the slide mechanism. The sensors U9 and U12 are used to determine the calibration position. Sensors U16 and U22 are used to determine the hood position during normal operation. The output is normally *high*. These devices provide a *low* output if a significant south pole magnetic field is applied to their surface.

Remote Light Alarm Indicator

DS1 provides an alarm indication with a high field of view and is illuminated by a positive signal (RMLITE) at the gate of transistor Q3.

Scale Interface

Connector J3 provides the interface and power for the scale module. The scale module supports serial data communication. The signal SCCLK is used for scale communication only and is normally high when the scale is disconnected. The signal CDATA is bi-directional and is normally in the low state when the scale is not connected.

Fan Control/Feedback Circuit

To drive the DC fan on the sensor board, Q1 is pulsed on its gate by signal *FANON* at a 50% duty cycle at approximately 48 Hz to maintain proper speed and to increase fan life. Every 4 seconds the microcontroller asserts *FANON* for 42 msec, and the fan pulse detection begins.

The pulse detection is handled by U1A, which through resistors R3 and R7 sample the current spikes from the fan produced across R1. The amplifier operates as a differentiator, providing high gain for the current spikes. This signal is then rectified and filtered by D1 and C16 and then fed to the A/D converter as signal *FANPUL*. This effectively provides a semi-DC level as a function of the fan rotation.

Temperature Measurement

The temperature data acquisition circuit starts with analog multiplexer U6 and U5, each allowing an 8 to 1 signal switching. The multiplexer channel selection is accomplished from the microcontroller by the signals *MSEL0*, *MSEL1*, and *MSEL2*. Each multiplexer output can be inhibited by either the signal *TMISEL* or *TM2SEL*, depending on the multiplexer (only one multiplexer is active at a time). With each multiplexer output into the amplification under control, this data acquisition can then be viewed as 16 to 1 analog temperature selector. The microcontroller selects a new temperature channel every 21 milliseconds.

Resistor R14 provides the constant voltage drive required for each thermistor as it gets selected from the appropriate multiplexer. This voltage is amplified by a factor of 2.1083, and then sent to the A/D converter as signal *TCOM*.

To provide automatic calibration of the circuit (and eliminate temperature and aging drifts), precise calibration values are introduced into each multiplexer. These values are provided by R44 and R45, which are read through the multiplexers and are used in software processing to eliminate the gain and offset errors of each multiplexer/amplifier combination. These values equate to 120.87°F (49.37°C) and 72.72°F (22.62°C), which allows for precise circuit calibration.

Resistor R43 is an additional check to the circuit. It provides a resistance simulating 98.57°F (36.99°C).

The sensor module supports three air temperature sensors on the sensor board: signals AIRTE, AIRTC and AIRTM. These signals are interfaces via J2-6 to J2-8. These thermistors are then routed to temperature multiplexer U5 and U6, which provide analog signal processing into the A/D converter.

The skin temperature probes contain dual thermistors. The sensor module can support two probes, which can be plugged into connectors J6 and J7. The two thermistors are connected to SKNTXM and SKNTXC (X is either 1 or 2), with a common connector at AGND. Both probes have high frequency filtering by inductor networks LN1 and LN2. In addition, each skin probe has a resistor that is input to the multiplexers. These signals (SKNT1D and SKNT2D) are used by the microcontroller to determine whether the probes are installed.

Humidity Measurement

Humidity measurement originates with the humidity sensor on the sensor P.C. board, connected to J2-5 and J2-14 (AGND and HS2, respectively). The sensor is a capacitive type, which changes capacitance as a function of humidity (the net range of capacitances is from approximately 160 pF to 200 pF). The sensor is connected to amplifier U7A/U8A, which is set up as a multi-vibrator. The sensor capacitance is allowed to charge up through R20 and R21 up to a threshold voltage established by R30 and R26. When the capacitor voltage reaches the threshold, capacitor U7A/U8A goes high (to 2.5V as controlled by R19 and R28) which turns on Q2. This then discharges the humidity sensor through R20, until it reaches the lower threshold established by R24, R26, and R30. The capacitor voltage goes from approximately 0.2 V to 0.7V. At this point the comparators output goes low, releasing the drive to Q2 and allowing the humidity to start charging again. This effectively produces a frequency output as a function of capacitance, such as humidity.

The output signal, which is only 2.5V peak, is then input into U7B/U8B to condition the 5V signal. Hysteresis is provided through the use of R23, R29 and R32 to insure stable frequency switching. The output signal JUMPUL is then sent to the microcontroller for processing. A typical frequency would be around 37 KHz.

Microcontroller

The microcontroller is a PIC 16C73, used for signal processing and control of all signals on the sensor module. The device has three external ports, configurable as inputs, outputs, etc. The microcontroller operates from a precise time base of crystal Y1, operating at 4 MHz. The instruction cycle time of the PIC controller is ¼ of that, namely at 1 MHz or 1 microsecond.

To ensure a clean power-up, U10 provides a fixed power-up reset to the microcontroller. In addition, this integrated circuit generates a rest in the event the D+5 falls below a predetermined threshold (brownout condition).

The reset line of the microcontroller, *SMRES*, is also available to the main controller if the main controller determines that the sensor module requires reset intervention.

The PIC device is operating with an internal watchdog timer device which asserts *SMRES* in the event the program execution is operating outside normal conditions.

Expansion Devices

The digital multiplexer, U3, is employed to allow additional digital signals for processor control. It is a dual, 4-to-1 multiplexer, which allows the microcontroller to use two ports for 8 bits of information. Control of U18 is provided by signals *DVSELO* and *DVSEL1*.

Buffered line drivers U13A/B and U14A are used for signals that are going off-board, namely *SMDATA*, *SCDATA* and *SCCLK*. The *SMDATA* line is used as a bi-directional line, which can be changed from input or output “on-the-fly” for data communication to the main controller. The *SCDATA* is similar, with connection to the scale at connector J3. *SCCLK* is the buffered clock line used for scale communications.

Buffer U14B provides an inversion for *TMISEL*, producing *TM2SEL*, which alternately enables/disables temperature multiplexers.

Analog/Digital (A/D) Conversions

The A/D converter, U11, is an 8-channel, 12-bit, serial, interface device. Control for the channels is software configurable by the serial communication line *SSPCLK*, *ADCDIN* and *COMOUT*. The A/D converter is enabled for signal processing by the signal *ACENI*, which is asserted twice every 21 milliseconds (the A/D converter is read twice). In addition, the *ADCIN* and *COMOUT* are also driven at 21 millisecond intervals. The *SSPCLK* is shared with the EEPROM on the sensor board and scale clock; therefore, the timing is not periodic.

All temperature information is presented as a multiplexed signal on Channel 0, and oxygen information is presented as a multiplexed signal on Channel 2. Channel 4 allows the A/D converter to read its maximum input, and Channel 5 allows the A/D converter to read its minimum input. This allows determination of proper A/D functioning.

The analog representation of fan pulses is applied to Channel 6.

Controller

The controller is designed to accept input voltages between the range of 90V AC and 264V AC. This is accomplished by the use of a universal input switching power supply. Voltages above the safe operating range are clamped using transorb diode.

The controller is designed to accept input frequencies between the range of 48 Hz to 62 Hz. This is accomplished by the use of a universal input switching power supply.

The stand supplies the input power and protective ground to the controller. The stand incorporates a 15A circuit breaker and EMI filtering components.

The controller provides AC power to the heater and the humidifier. These outputs are fused in the controller to protect the controller in the event of a short circuit or electrical overload.

- Maximum heater voltage—264V AC
- Maximum heater current—4.8 A
- Maximum humidifier voltage—264V AC
- Maximum heater current—1.2 A
- Heater/humidifier fuse rating—6.3 A

The controller provides DC power to the fan, sensor module, scale, SPO₂ module (if available), airflow sensors, and door switches. These outputs are current limited in the controller to protect the controller and the powered device in the event of a short circuit or electrical overload. These outputs are regulated to ensure the output voltage is within the voltage specification for the powered device. The microprocessor feeds and monitors the outputs 1 and 2 into the A/D converter.

Impeller Movement Detector (IMD) P.C. Board

The IMD P.C. board is positioned so magnets pressed into the bottom of the impeller pass directly over a hall effect sensor mounted to the P.C. board. The IMD circuit monitors the hall-effect sensor pulse train produced by the magnets when the impeller rotates. The speed of the impeller is measured and compared with pre-determined maximum and minimum acceptance limits. If the impeller's rotational speed is too fast or too slow, an impeller error signal is generated. The IMD circuit also detects if one, two, or all three magnets are missing or an old impeller without magnets is being used. These errors produce the same error signal to the controller as for low or high impeller speeds.

The system controller's +12V through a 301 Ω resistor supplies the power for the IMD circuit. This resistor and the load of the IMD circuit forms a voltage divider that sets the LONG signal voltage which remains constant. U1, a voltage regulator, supplies +5V DC to U3, the hall-effect sensor and U2, the microcontroller. As the magnets pass above, the hall-effect sensor open-drain output, U3-2, goes low detecting the magnets field. When this field is removed, oscillator as a reference. When an error condition is detected U2-2, the microcontroller's output is driven low turning off Q1, releasing a portion of the load on the short signal allowing it to rise above the LONG signal voltage. R2, the switch portion of the SHORT signal load, and R4, the unswitch position of the SHORT signal load, are adjusted to provide approximately a 1V swing between error and non-error outputs. Capacitors C1 and C2 are provided for system supply filtering.

The IMD P.C. board supports in-circuit programming (ICP) of the microcontroller. Programming is done after the unprogrammed microcontroller is populated with all the other components by connecting a programmer to the pads labeled VPP, +5V, CLK, DTA, and GND.