

SpeedClave[®] Steam Sterilizers



Model Numbers:
M7 -020 thru -022

Serial Number Prefixes:

V

Service and Parts Manual

"NO LONGER IN PRODUCTION"
Some service parts may not be available for this product.

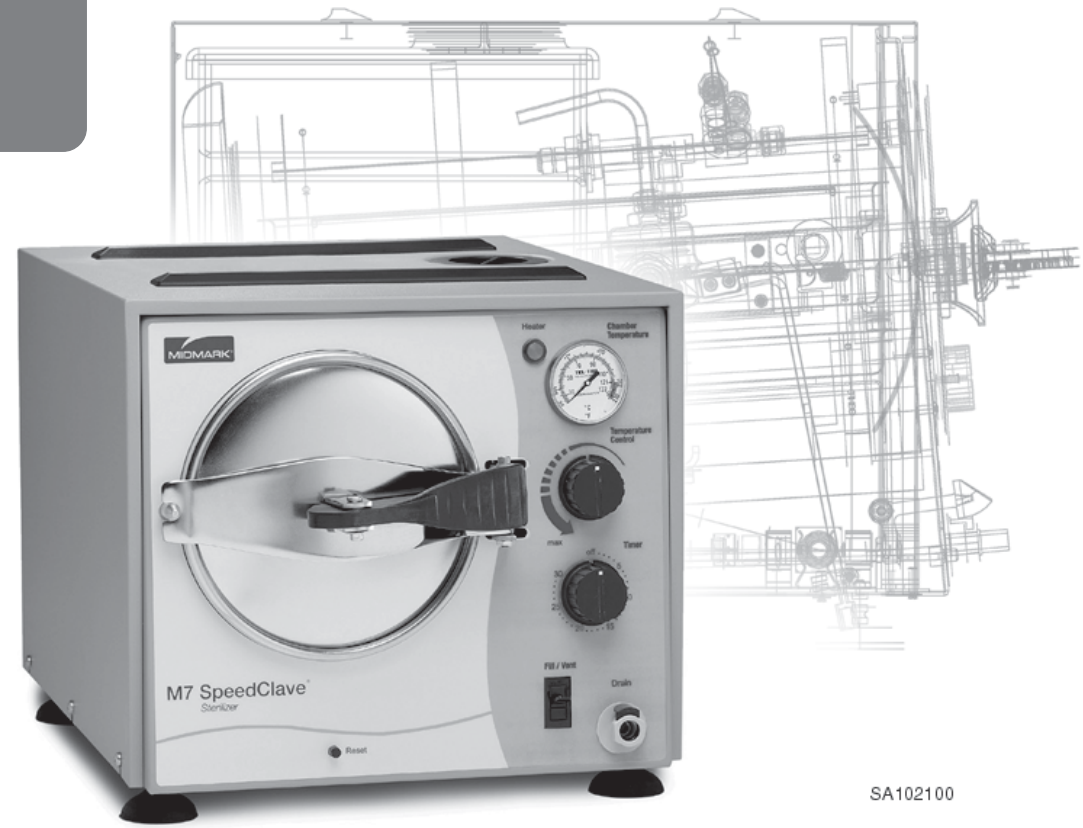

SA102100



FOR USE BY MIDMARK TRAINED TECHNICIANS ONLY

Table Of Contents

General Information

GENERAL INFORMATION

Symbols	i
Ordering Parts	i
Model / Serial Number	
Location	i
Weights, Dimensions, Electrical Specifications	ii
Model Identification / Compliance Chart	iii
Special Tools	iv
Warranty Information	iv

Section A

OPERATION & TROUBLESHOOTING

Electrical System:	
M7 (-020 thru -022)	A-3
Filling the Chamber	A-6
Heat-Up / Sterilization	A-10
Venting the Chamber	A-16

Section B

TESTING & REPAIR

Checking for	
Pressure Leaks	B-2
Fuse	B-3
Bellows	B-4
Fill / Vent Valve:	B-6
Temperature Regulator Assy ..	B-10
Heating Element	B-16
Overheat Thermostats	B-20
Pressure Relief Valve	B-23
Timer	B-24
Timer Buzzer	B-28
Temperature Gauge	B-29
Door Assembly	B-30
Reservoir Tank	B-32
Chamber Assembly	B-34

Section C

ACCESS PROCEDURES

Removing & Installing:	
Covers / Panels	C-2
Tray Plate / Rack	C-3
Draining / Filling Reservoir	C-4

Section D

WIRING DIAGRAMS & SCHEMATICS

115 VAC models:	
M7 (-020 / -022)	D-2
230 VAC models:	
M7 (-021)	D-3

Section E

EXPLODED VIEWS / PARTS LISTS

M7 (-020 thru -022):	E-2
----------------------------	-----

Symbols



Caution

Indicates a potentially hazardous situation which could result in injury if not avoided.



Equipment Alert

Indicates a potentially hazardous situation which could result in equipment damage if not avoided.

Note

Amplifies a procedure, practice, or condition.



Indicates that the component the check mark appears beside should be tested before replacing it. In Section A, test the components in the order indicated. (ex. **1st** ✓ then, **2nd** ✓)

Refer to Section B for component testing procedures.

Ordering Parts

The following information is required when ordering parts:

- Serial number & model number
- Part number for desired part.

[Refer to Section E: Exploded Views / Parts Lists]

Non-warranty parts orders may be faxed to Midmark using the Fax Order Form in the back of this manual.

For warranty parts orders, call Midmark's Technical Service Department with the required information.

Hours: 8:00 am until 5:00 pm EST [Monday - Friday]

Phone: 1-(800)-Midmark

Model / Serial Number Location

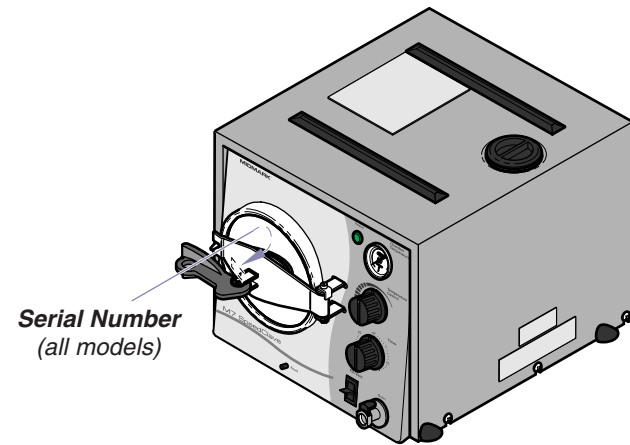

Serial Number
(all models)

Model & Serial Number

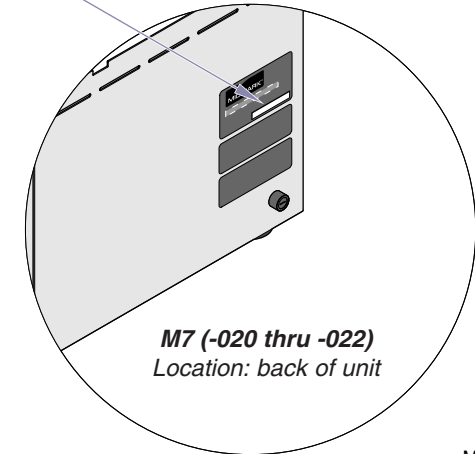

M7 (-020 thru -022)
Location: back of unit

MA511503i

General Information

Weights, Dimensions, Electrical Specifications

ATTENTION

A separate (dedicated) electrical circuit is recommended for all models.
Do not connect to a circuit with other devices, unless the circuit is rated for the additional load.

M7 (-020 thru -022)

Dimensions [Refer to illustration]:

Height (A)	13 in. (33 cm)
Width (B)	14 in. (35.6 cm)
Depth (C)	19 in. (48.3 cm)

Chamber Size:	Diameter: 7.5 in. (19 cm)
	Depth: 14.25 in. (36.2 cm)

Shipping Carton:

(Length x Width x Height)	24 in. x 16 in. x 16 in.
	(61 cm x 40.6 cm x 40.6 cm)

Weight:

Shipping Weight	39 lbs (17.7 kg)
w/reservoir empty	30 lbs (13.6 kg)
w/reservoir full	41.8 lbs (19 kg)

Reservoir Capacity:	Approx. 1.3 gallon (4.9 liters)
	at FULL mark

Pressure Relief Valve:

opens at approximately:	34 psi (234 kPa)
-------------------------------	------------------

Electrical Requirements:	[See Model Identification / Compliance Chart]
---------------------------------------	---

Power Consumption:

115 VAC models	1300 watts, 10 amps @ 115 VAC
230 VAC models	1300 watts, 5 amps @ 230 VAC

Fuse (back of unit):

115 VAC models	12 amp, 250 V, Fast-Acting, 1/4" x 1-1/4"
230 VAC models	8 amp, 250 V, Fast-Acting, 5 x 20 mm

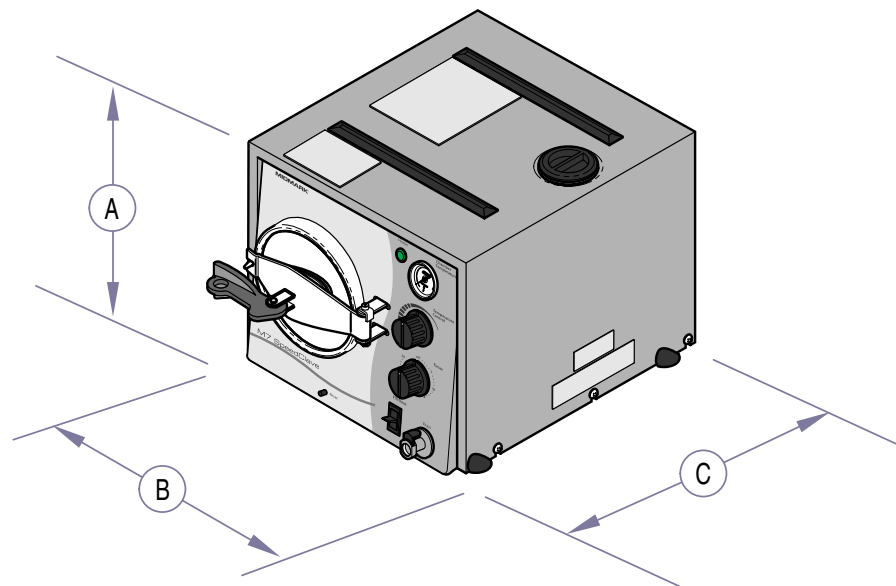

MA6706001

Model Identification / Compliance Chart

Model	Description	Serial Number Prefixes	Complies To:				Electrical Ratings:		
			UL 544	UL 61010A-1 61010-2-041	CAN/CSA C22.2, #151	CAN/CSA C22.2, #1010 #1010.2-041-96	VAC	Amps	Cycles (Hz)
M7-020	Midmark M7 Sterilizer <i>(115 VAC)</i>	V		X		X	115	10	60
M7-021	Midmark M7 Sterilizer <i>(230 VAC)</i>	V		X		X	230	5	50
M7-022	Ritter M7 Sterilizer <i>(115 VAC)</i>	V		X		X	115	10	60



General Information

Special Tools

This table lists all special tools needed to diagnose and repair the sterilizer.

Special Tool	Manufacturer	Part Number	Purpose of Tool
Digital Multimeter	Commercially available	any type	To perform continuity / voltage checks
Digital Thermometer	Commercially available	any type	To verify chamber temperature

Warranty Information

SCOPE OF WARRANTY

Midmark Corporation (“Midmark”) warrants to the original purchaser its new Alternate Care products and components (except for components not warranted under “Exclusions”) manufactured by Midmark to be free from defects in material and workmanship under normal use and service. Midmark’s obligation under this warranty is limited to the repair or replacement, at Midmark’s option, of the parts or the products the defects of which are reported to Midmark within the applicable warranty period and which, upon examination by Midmark, prove to be defective.

APPLICABLE WARRANTY PERIOD

The applicable warranty period, measured from the date of delivery to the original user, shall be one (1) year for all warranted products and components.

EXCLUSIONS

This warranty does not cover and Midmark shall not be liable for the following: (1) repairs and replacements because of misuse, abuse, negligence, alteration, accident, freight damage, or tampering; (2) products which are not installed, used, and properly cleaned as required in the Midmark “Installation” and or “Installation / Operation Manual for this applicable product. (3) products considered to be of a consumable nature; (4) accessories or parts not manufactured by Midmark; (5) charges by anyone for adjustments, repairs, replacement parts, installation, or other work performed upon or in connection with such products which is not expressly authorized in writing in advance by Midmark.

EXCLUSIVE REMEDY

Midmark’s only obligation under this warranty is the repair or replacement of defective parts. Midmark shall not be liable for any direct, special, indirect, incidental, exemplary, or consequential damages or delay, including, but not limited to, damages for loss of profits or loss of use.

NO AUTHORIZATION

No person or firm is authorized to create for Midmark any other obligation or liability in connection with the products.

ADDITIONAL INFORMATION

Failure to follow the guidelines listed below will void the warranty and/or render the table unsafe for use.

- If a malfunction is detected, do not use the table until necessary repairs are made.
- Do not attempt to disassemble table, replace components, or perform adjustments unless you are a Midmark authorized service technician.
- Do not use another manufacturer's parts to replace malfunctioning components. Use only Midmark replacement parts

THIS WARRANTY IS MIDMARK’S ONLY WARRANTY AND IS IN LIEU OF ALL OTHER WARRANTIES, EXPRESS OR IMPLIED. MIDMARK MAKES NO IMPLIED WARRANTIES OF MERCHANTABILITY OR FITNESS FOR ANY PARTICULAR PURPOSE. THIS WARRANTY IS LIMITED TO THE REPAIR OR REPLACEMENT OF DEFECTIVE PARTS.

SF-1487 REV. A1

Section A

Operation & Troubleshooting

<u>Mode</u>	<u>Page</u>
Electrical System: M7 (-020 thru -022) ..	A-3
Filling the Chamber	A-6
Heat Up / Sterilization	A-10
Venting the Chamber	A-16

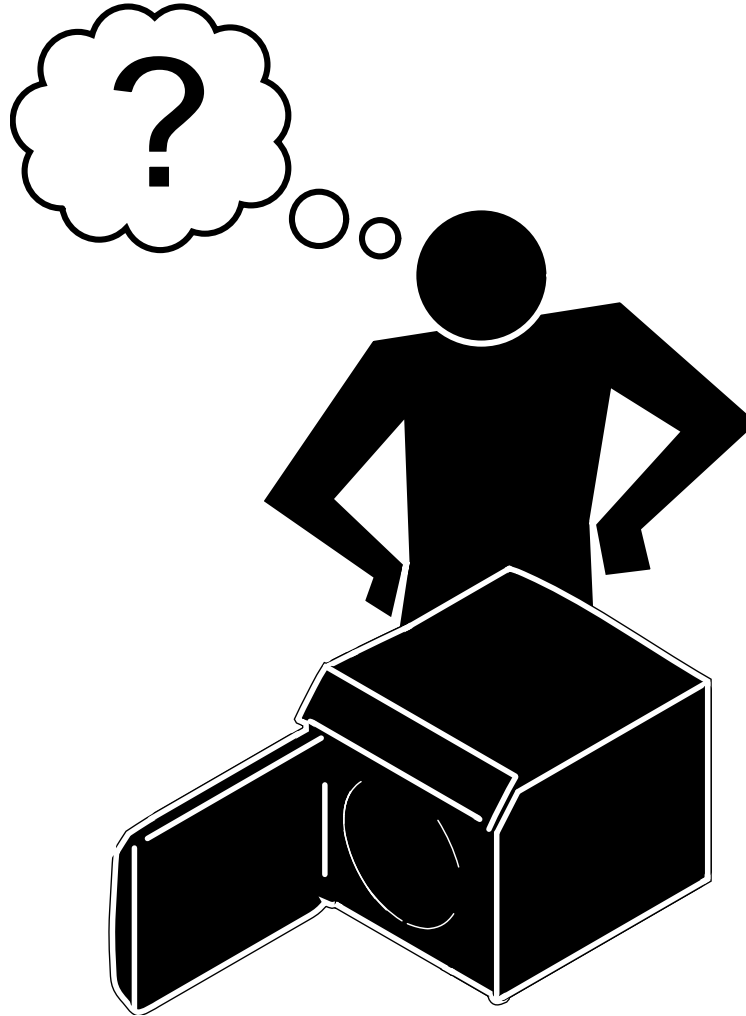

Operation & Troubleshooting

Electrical System - [M7 (-020 thru -022)]

The illustration shows all of the electrical components of the sterilizer. Refer to the following page for a detailed description of current flow.

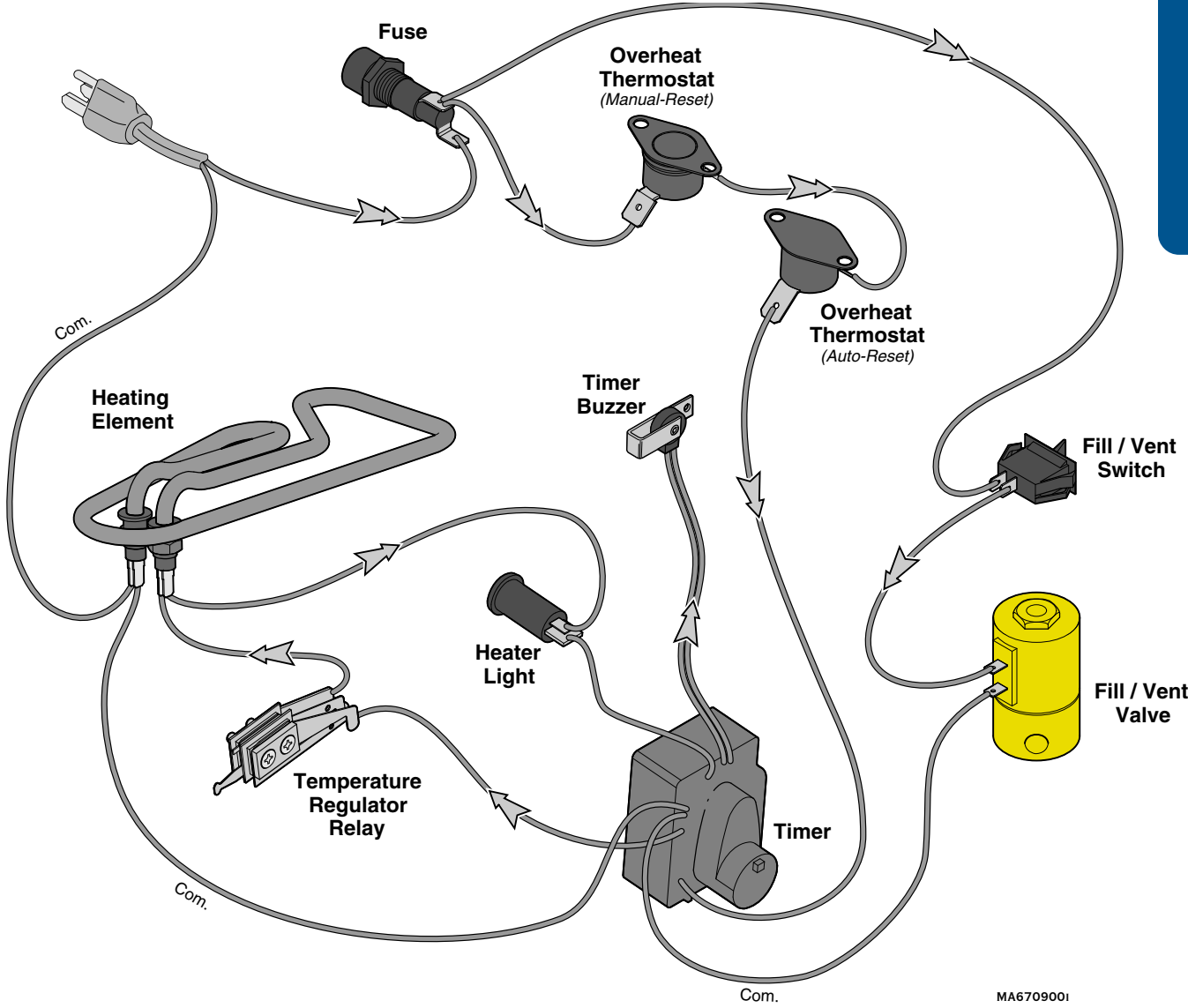

Troubleshooting [Electrical System]	
Problem:	Page
<i>When Fill/Vent Switch is pressed:</i>	
- Chamber does not FILL	A-8
- Chamber does not VENT	A-18
<i>Heating element does <u>not</u> turn ON:</i>	
- Heater light is OFF	A-4
- Heater light is ON	A-5
<i>Sterilizer shuts down before timer setting expires</i>	
Timer buzzer does not function	A-15

Operation & Troubleshooting

Electrical System - [M7 (-020 thru -022)]

With the power cord properly connected...

Fuse

Current (115 / 230 VAC) continuously flows thru the fuse located in the back of the unit. This current supplies power to the fill / vent switch and the overheat thermostats.

Fill / Vent Switch

Current is supplied to the fill / vent switch thru the fuse.

Overheat Thermostats & Timer

Current is supplied to the two overheat thermostats thru the fuse.

Current continuously flows thru the thermostats to the timer.

If either thermostat opens (*overheat or malfunction*), voltage is removed from the timer until the thermostat is reset or replaced.

NOTE

The Manual-Reset Thermostat contacts open at approximately 285°F (140°C). To reset, allow unit to cool, then press RESET button on front of unit.

The Auto-Reset Thermostat contacts open at approximately 295°F (146°C). This thermostat automatically resets when the unit cools to approx. 265°F (129°C).

When filling the chamber (pressing the fill/vent switch)...

Fill / Vent Switch

The contacts of the (*normally open*) switch close. When the contacts of the switch are closed, current is supplied to the fill / vent valve.

Fill / Vent Valve

When current is applied to the (*normally closed*) valve, the valve opens. When the valve is open, water flows into the chamber.

When the Timer is turned ON...

Timer

The (*normally open*) timer contacts close, and voltage is supplied to the timer motor and the temperature regulator relay. The timer motor runs, and begins to count down the time it was set for.

(*The contacts to the timer buzzer remain open*).

When the timer is turned ON (continued)...

Temperature Regulator Relay

Current is supplied to the temperature regulator relay thru the timer. If the chamber temperature is lower than the temperature knob setting*, the relay contacts are closed. When these contacts are closed, current flows thru the relay to the heating element and the heater light.

[* *The minimum temperature knob setting is approx. 220°F (104°C)*]

The diaphragm cup of the relay expands as the temperature & pressure inside the chamber increase. When the chamber temperature reaches the temperature knob setting, the relay contacts open, and voltage is removed from the heating element & heater light.

Heater Light & Heating Element

When the contacts of the temperature regulator relay are closed, current is supplied to the heater light and the heating element.

As the relay contacts open and close, the heating element cycles ON / OFF. This continues until the timer setting expires.

The heater light is illuminated whenever the heating element is ON.

When the timer setting expires...

Timer & Timer Buzzer

The contacts to the temperature regulator relay open, stopping the current flow to the heater light & heating element.

The contacts to the timer buzzer close and current flows to the timer buzzer. When voltage is applied, the buzzer emits an audible signal.

The contacts to the timer motor remain closed for one minute. After one minute the contacts to the timer motor & the timer buzzer open, stopping the current flow to these two components.

When pressing the Fill / Vent Switch (to VENT the chamber)...

Fill / Vent Switch

The contacts of the (*normally open*) switch close. When the contacts of the switch are closed, current is supplied to the fill / vent valve.

Fill / Vent Valve

When current is applied to the (*normally closed*) valve, the valve opens. When the valve is open, steam is released thru the condensing coil & the water is returned to the reservoir .

Operation & Troubleshooting

Problem: Heating element does not turn ON.
[Heater light is OFF]

Refer To:	Page
Operation & Troubleshooting	A-1
Component Testing / Repair	B-1
Access Procedures	C-1
Wiring Diagrams	D-1
Exploded Views / Part Numbers	E-1

Loose / Damaged Wire Connections 4th ✓
Check all wiring connections.
(Power cord, overheat thermostats, etc.)

M7 (-020 thru -022) only 3rd ✓
Fuse

Timer 7th ✓

Temperature Regulator Assy. 6th ✓

Check supply voltage 2nd ✓
(A dedicated circuit is recommended)

Press RESET button 1st ✓
Allow unit to cool for 15-20 minutes
before pressing RESET button.

Overheat Thermostats 5th ✓

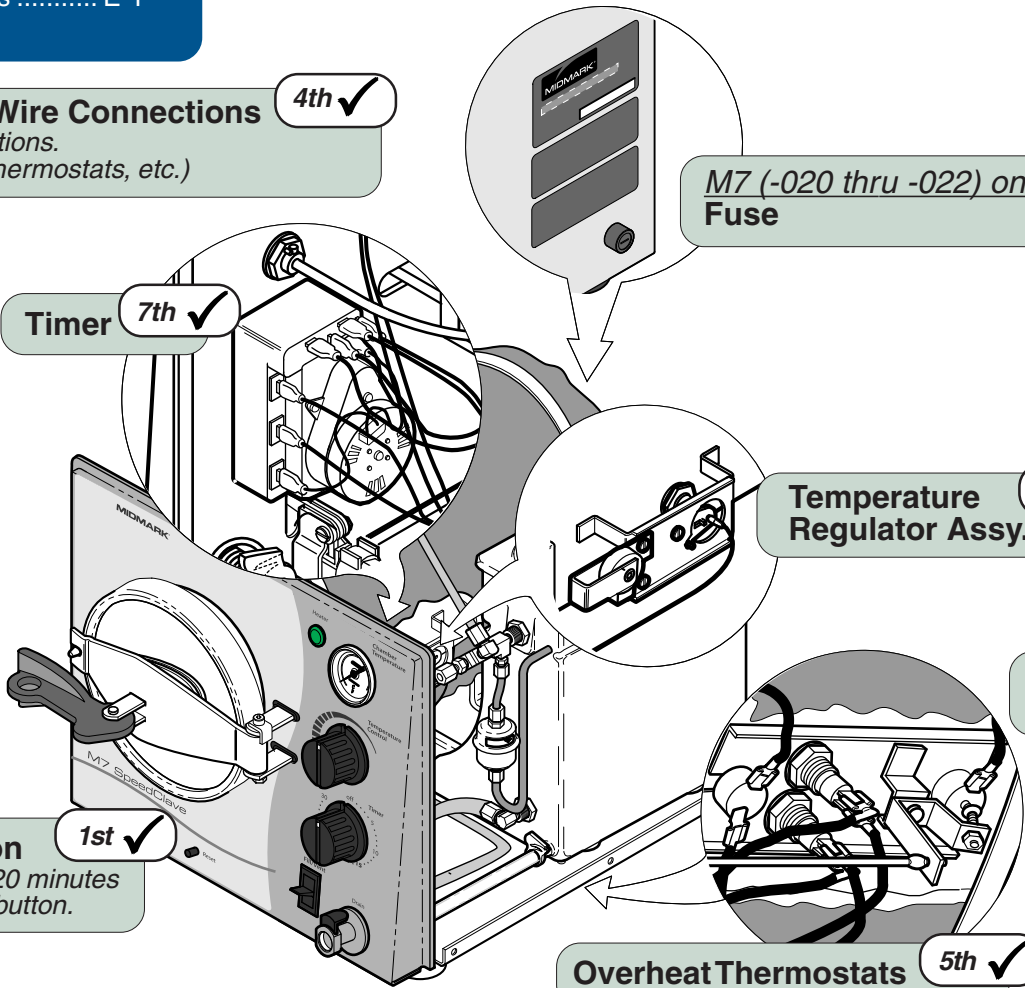

MA670800i

Problem: Heating element does not turn ON.
[Heater light is ON]

Refer To:	Page
Operation & Troubleshooting	A-1
Component Testing / Repair	B-1
Access Procedures	C-1
Wiring Diagrams	D-1
Exploded Views / Part Numbers	E-1

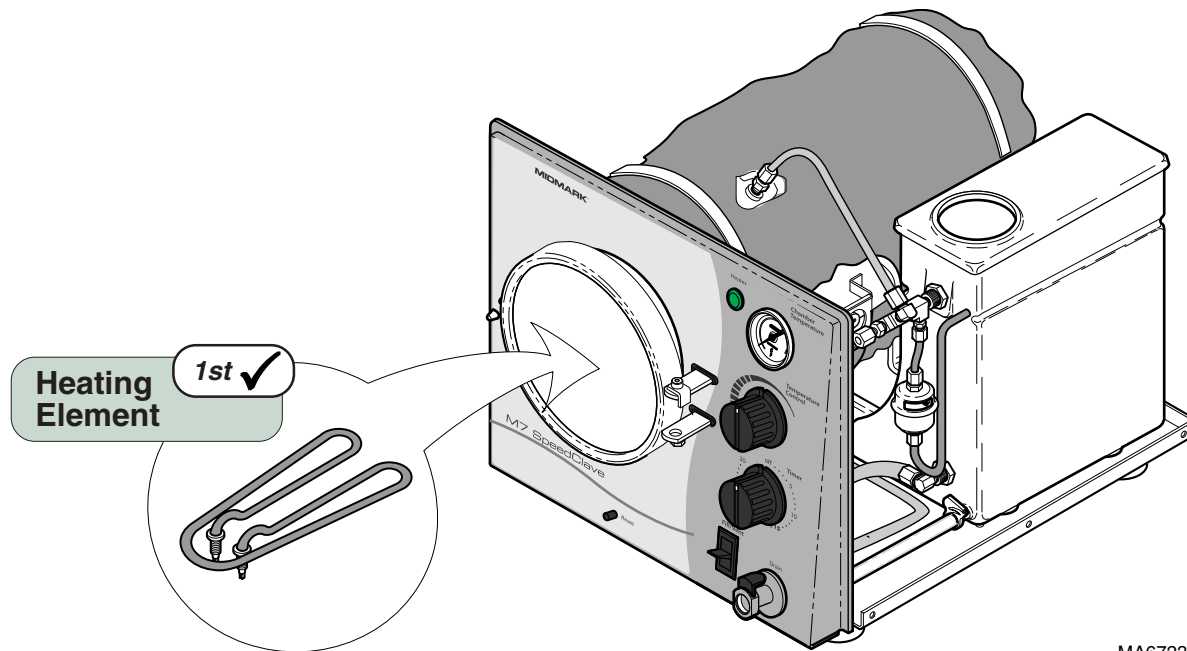

MA672300i

Models: | M7 (-020 thru -022) |
Serial Numbers: | all |

Electrical System

Operation & Troubleshooting

Filling the Chamber

The illustrations show the water flow when filling the chamber.
Refer to the following page for a detailed description of this process.

Problem:	Page
Chamber does not fill: - M7 (-020 thru -022)	A-8
Water continuously flows into chamber: - M7 (-020 thru -022)	A-9

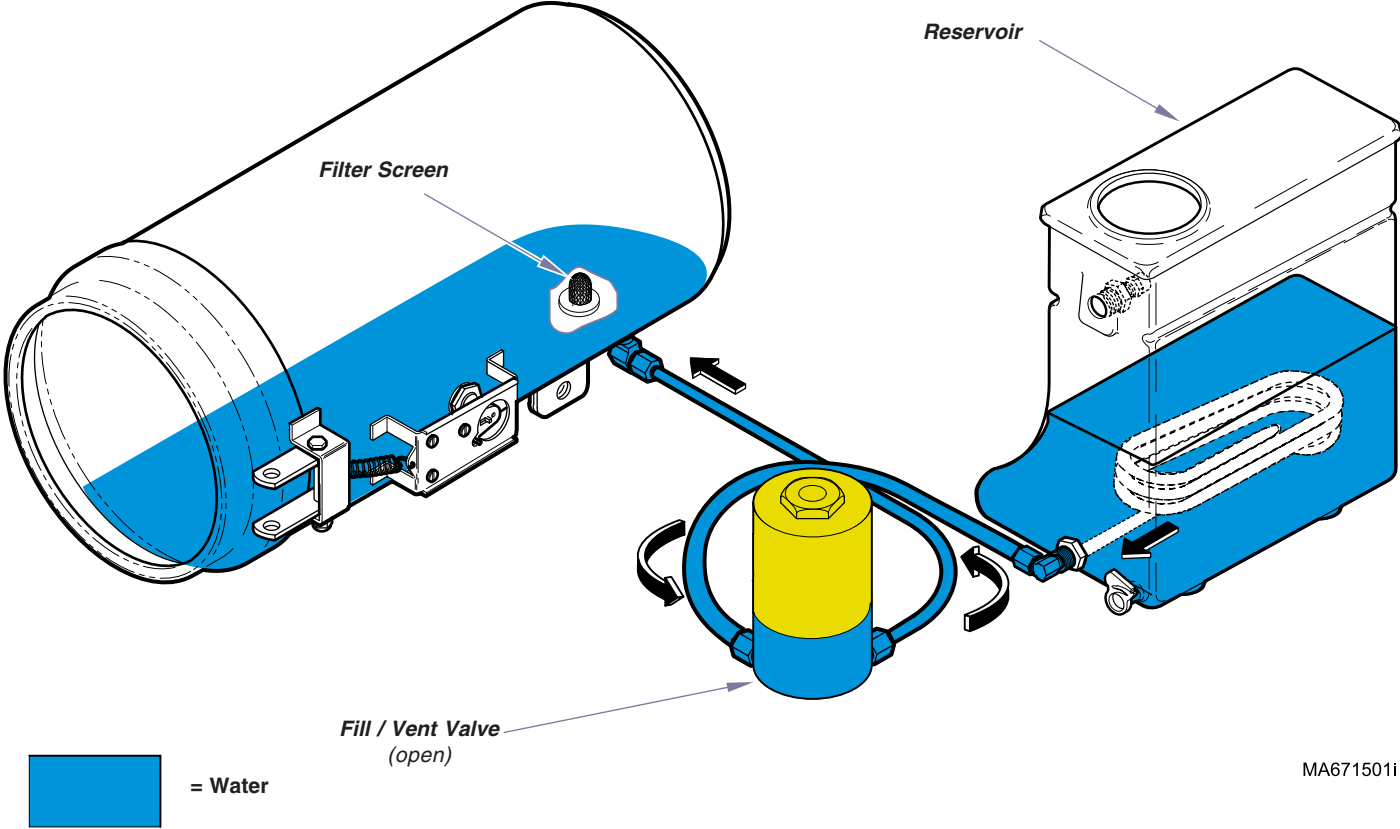

MA671501i

Filling the Chamber

When the Fill / Vent Switch is pressed and held...

Fill / Vent Switch & Valve

Current (*line voltage*) flows thru the fill/vent switch to the fill/vent valve. When voltage is applied, the (*normally closed*) fill / vent valve opens. When the valve is open, water from the reservoir flows into the chamber thru the valve and filter screen.

When the Fill / Vent Switch is released...

Fill / Vent Switch & Valve

The fill/vent switch opens, stopping the current flow to the fill/vent valve. When voltage is removed, the valve closes. When the valve closes, water stops flowing into the chamber.

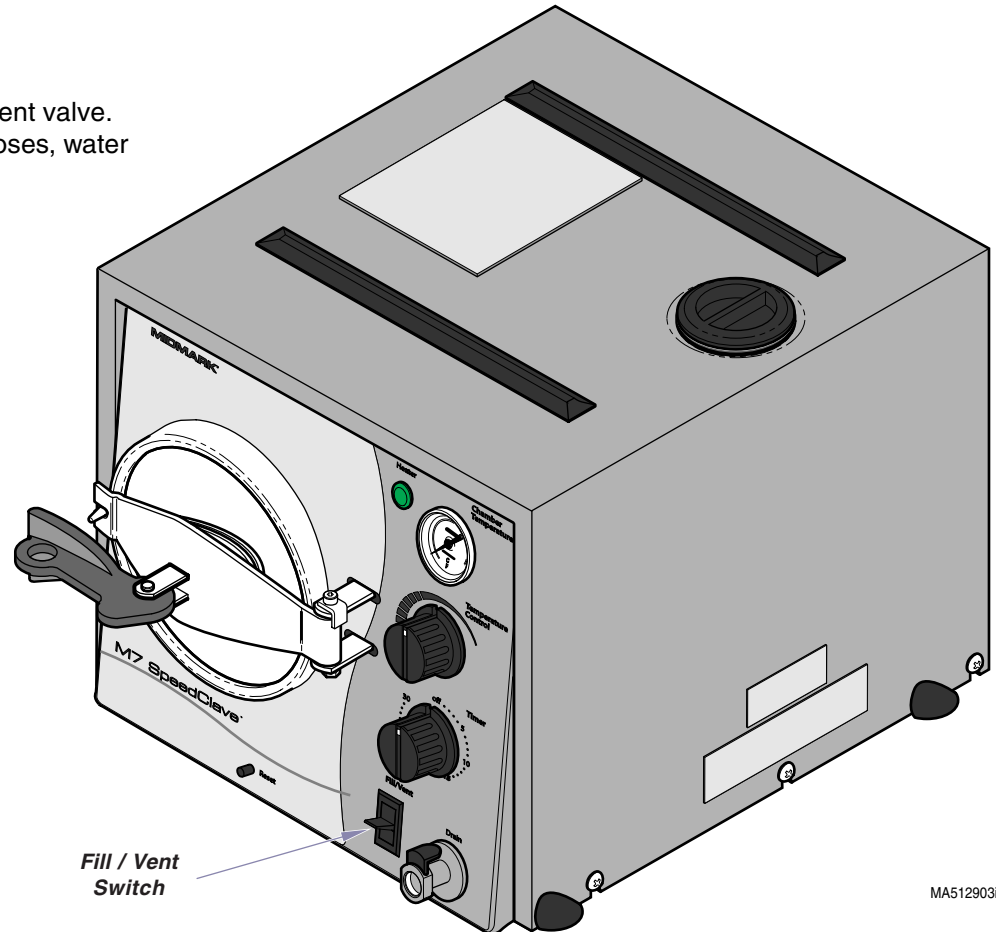

Models: | M7 (-020 thru -022) |
Serial Numbers: | all |

Filling the Chamber

Operation & Troubleshooting

Problem: Chamber does not fill.

Refer To:	Page
Operation & Troubleshooting	A-1
Component Testing / Repair	B-1
Access Procedures	C-1
Wiring Diagrams	D-1
Exploded Views / Part Numbers	E-1

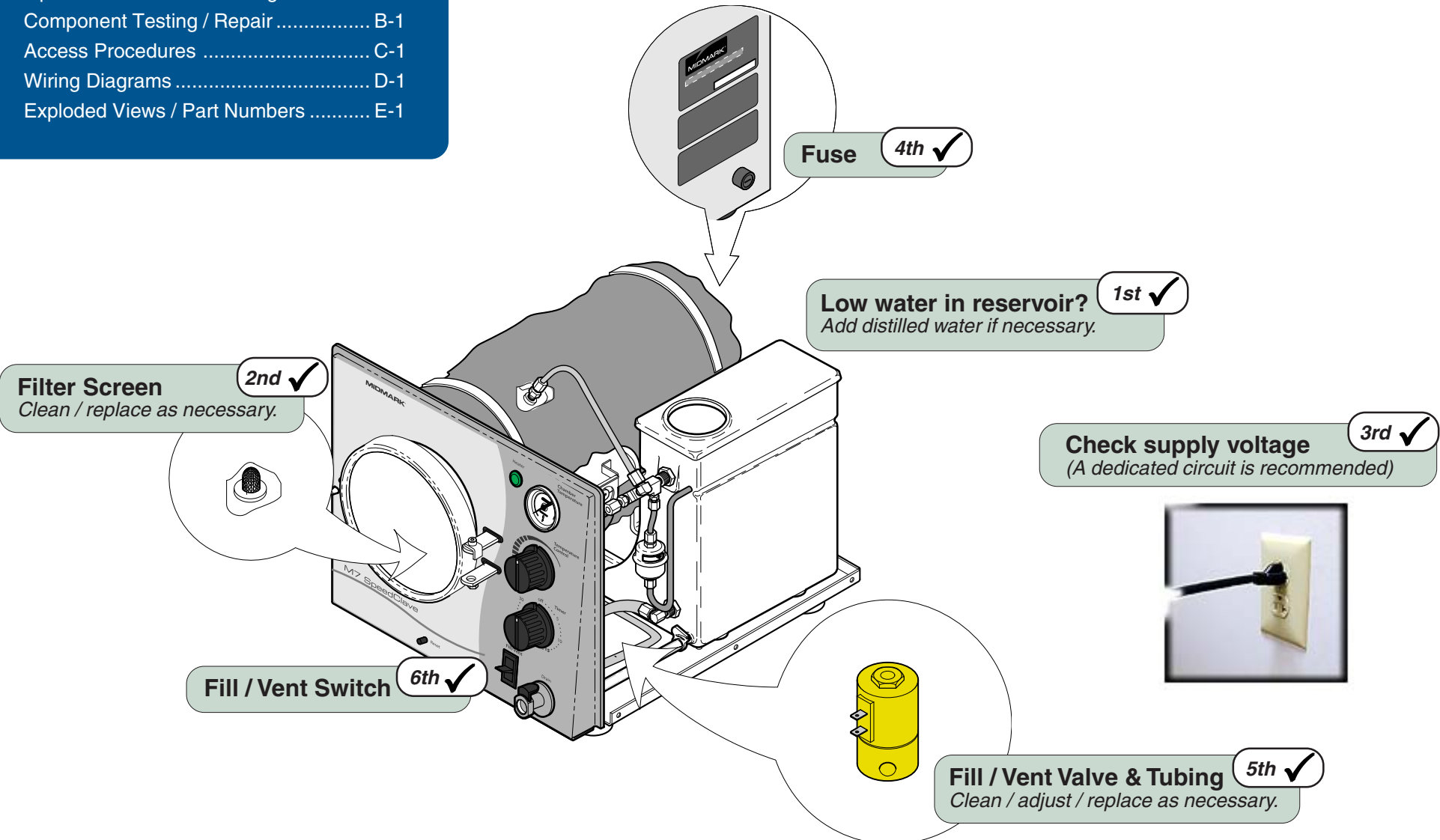

MA672500i

Operation & Troubleshooting

Problem: Water continuously flows into chamber.

Refer To:	Page
Operation & Troubleshooting	A-1
Component Testing / Repair	B-1
Access Procedures	C-1
Wiring Diagrams	D-1
Exploded Views / Part Numbers	E-1

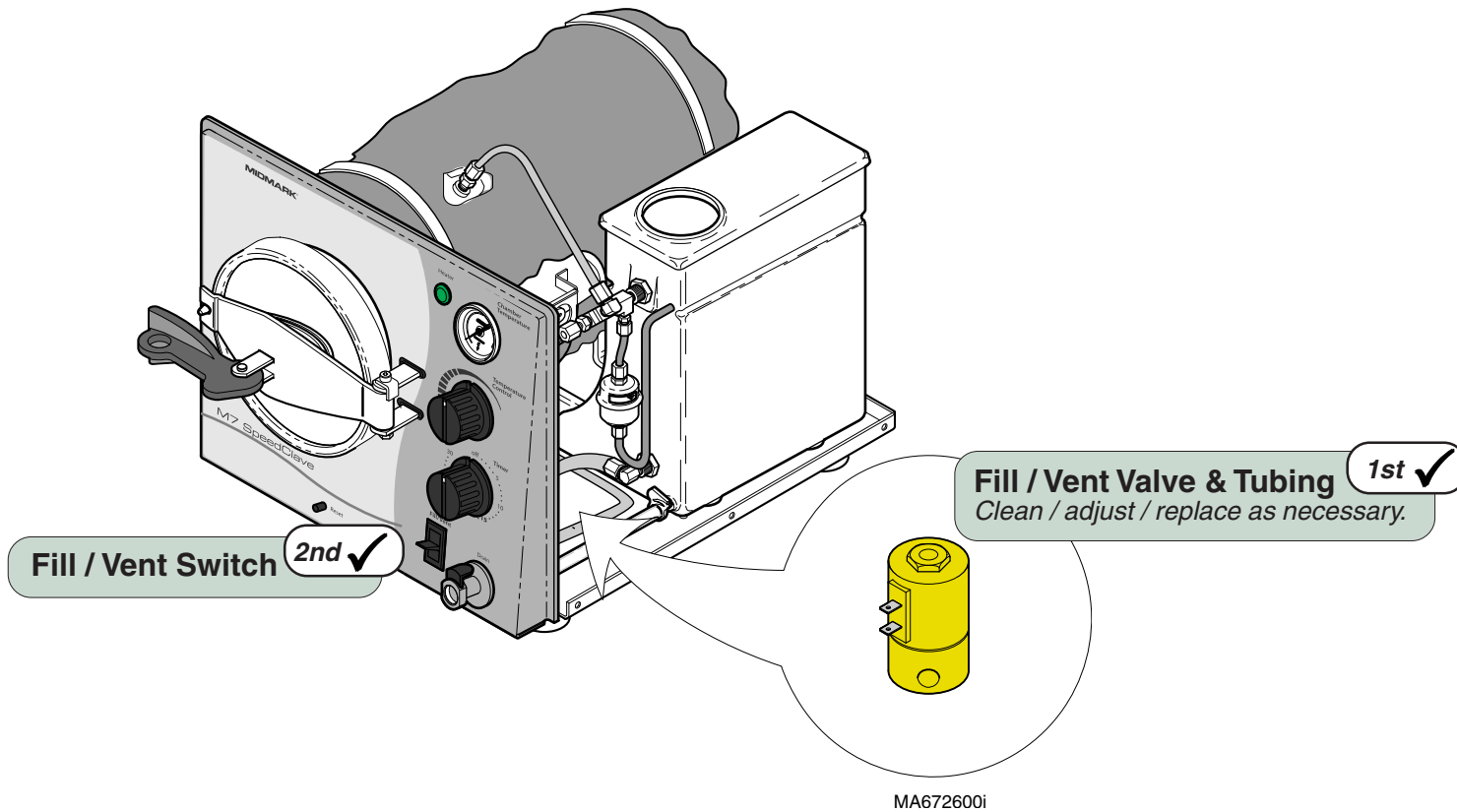

Models: M7 (-020 thru -022)
Serial Numbers: all

Filling the Chamber

Operation & Troubleshooting

Heat Up / Sterilization

The illustrations show the water / steam flow during heat up & sterilization. Refer to the following page for a detailed description of this process.

Heat-Up

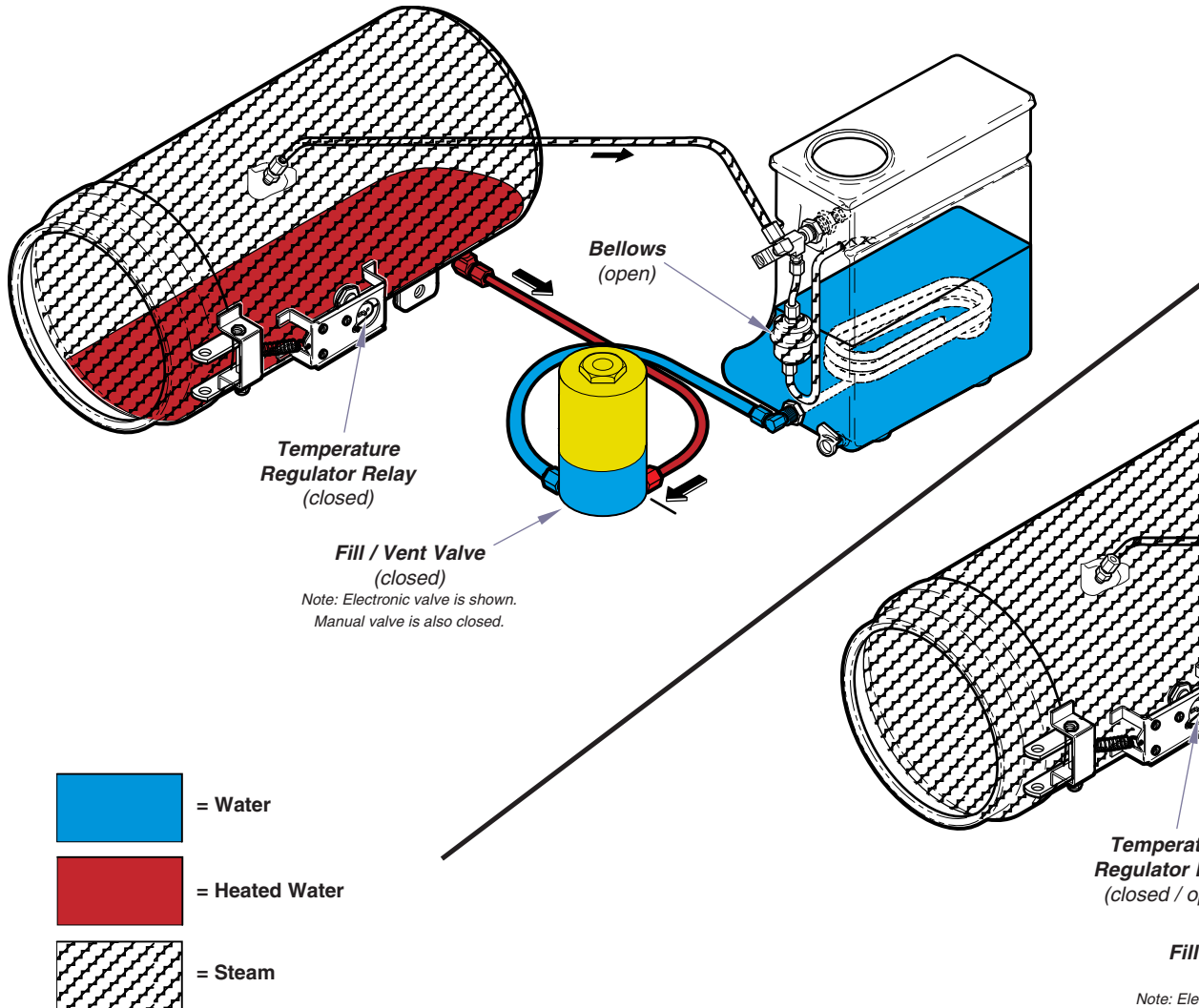

Sterilization

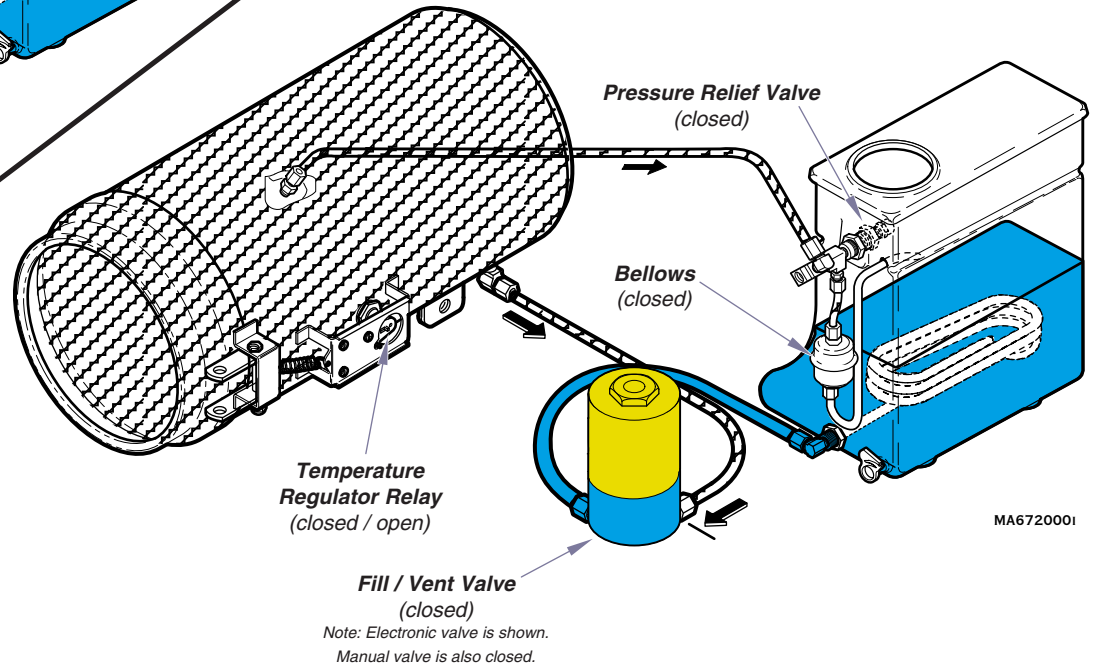

MA6720001

Troubleshooting [Heat-Up / Sterilization]

Problem:	Page
Heating element does <u>not</u> turn ON:	
- Heater light is OFF	A-4
- Heater light is ON	A-5
Heating element turns ON, but does not reach required temperature	A-12
Sterilizer shuts down before timer setting expires	A-13
Biological test strips indicate items are not sterile	A-14
Timer buzzer does not function	A-15

Heat-Up / Sterilization

When the timer is turned ON...

Timer

The (*normally open*) timer contacts close, and voltage is supplied to the timer motor and the temperature regulator relay. The timer motor runs, and begins to count down the time it was set for.
(*The contacts to the timer buzzer remain open*).

Temperature Regulator Relay

Current is supplied to the temperature regulator relay thru the timer. If the chamber temperature is lower than the temperature knob setting*, the relay contacts are closed. When these contacts are closed, current flows thru the relay to the heating element and the heater light.

[* *The minimum temperature knob setting is approx. 220°F (104°C)*]

The diaphragm cup of the relay expands as the temperature & pressure inside the chamber increase. When the chamber temperature reaches the temperature knob setting, the relay contacts open, and voltage is removed from the heating element & heater light.

Heater Light & Heating Element

When the contacts of the temperature regulator relay are closed, current is supplied to the heater light and the heating element.

As the relay contacts open and close, the heating element cycles ON / OFF. This continues until the timer setting expires.

The heater light is illuminated whenever the heating element is ON.

Bellows & Pressure Relief Valve

Heat-Up:

As the water in the chamber begins to boil, air is forced out of the chamber. This air passes thru the bellows into the reservoir.

Sterilization:

When pure steam begins to flow thru the bellows, the bellows closes allowing pressure to build in the chamber. If the pressure in the chamber exceeds 34 psi (234 kPa), the pressure relief valve opens to prevent unsafe conditions.

When the timer setting expires...

Timer & Timer Buzzer

The contacts to the temperature regulator relay open, stopping the current flow to the heater light & heating element.

The contacts to the timer buzzer close and current flows to the timer buzzer. When voltage is applied, the buzzer emits an audible signal.

The contacts to the timer motor remain closed for one minute. After one minute the contacts to the timer motor & the timer buzzer open, stopping the current flow to these two components.

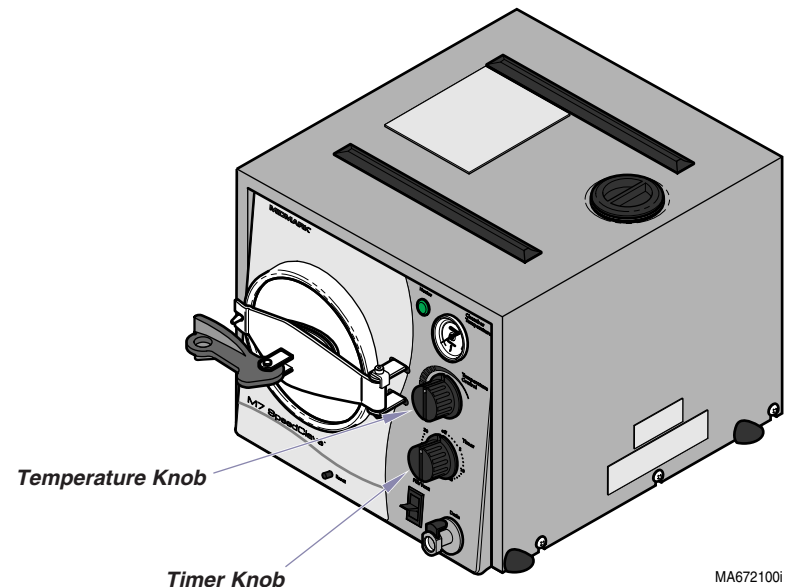

Operation & Troubleshooting

Problem: Heating element turns ON, but does not reach required temperature.
[Heater light is ON]

Refer To:	Page
Operation & Troubleshooting	A-1
Component Testing / Repair	B-1
Access Procedures	C-1
Wiring Diagrams	D-1
Exploded Views / Part Numbers	E-1

Check for pressure leaks. 1st ✓
Refer to Section B for checkpoints.

Temperature Regulator Assy. 2nd ✓

Heating Element 3rd ✓

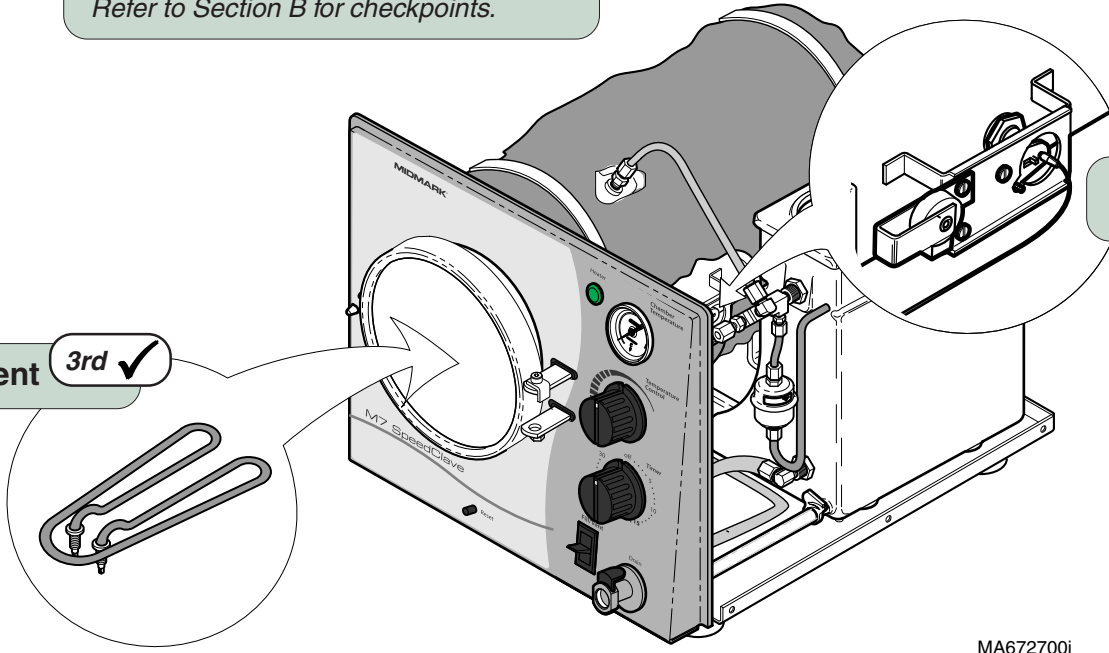

MA672700i

Problem: Sterilizer shuts down before timer setting expires.

Refer To:	Page
Operation & Troubleshooting	A-1
Component Testing / Repair	B-1
Access Procedures	C-1
Wiring Diagrams	D-1
Exploded Views / Part Numbers	E-1

Check for pressure leaks. 1st ✓

Refer to Section B for checkpoints.

Timer 5th ✓

Temperature Regulator Assy. 4th ✓

Overheat Thermostats 3rd ✓

Press RESET button 2nd ✓

Allow unit to cool for 15-20 minutes before pressing RESET button.

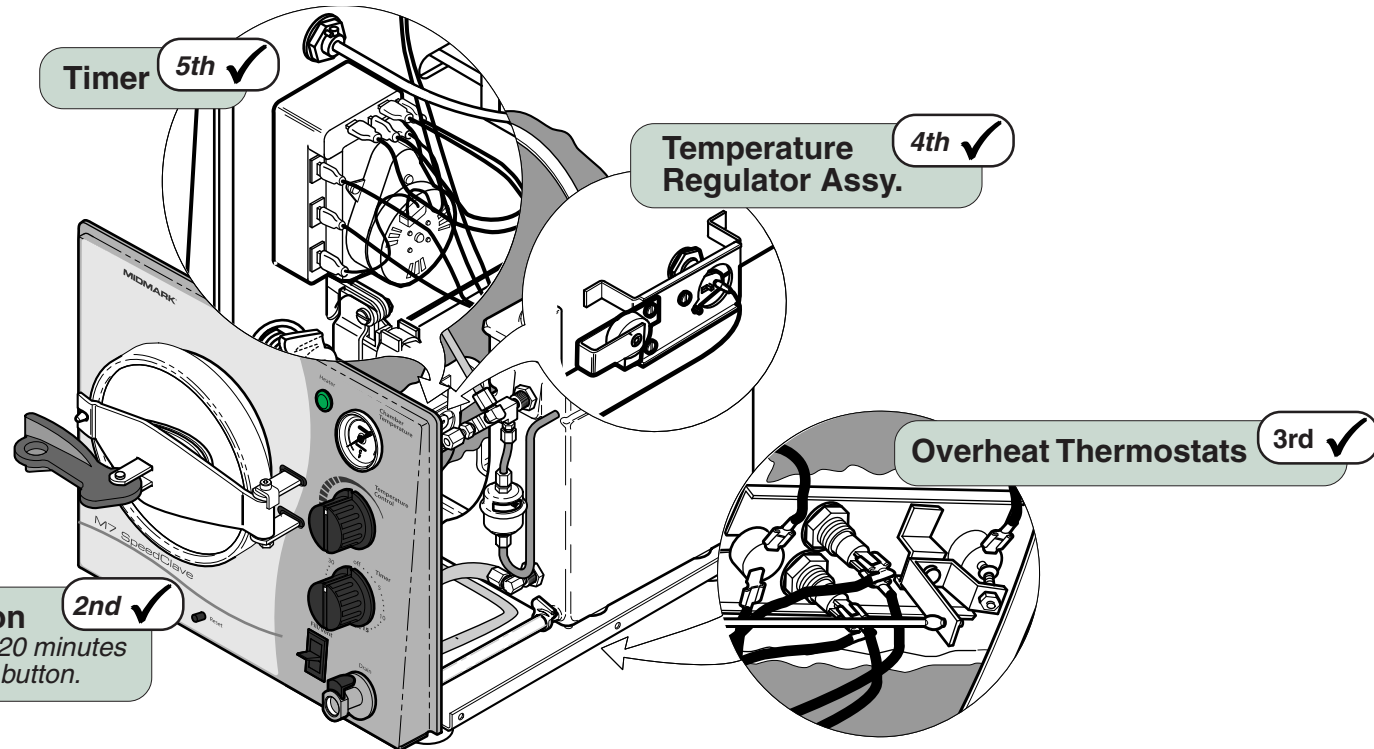

MA672800i

Models: | M7 (-020 thru -022) |
Serial Numbers: | all |

Heat-Up / Sterilization

Operation & Troubleshooting

Problem: Biological test strips indicate items are not sterile.

Refer To:	Page
Operation & Troubleshooting	A-1
Component Testing / Repair	B-1
Access Procedures	C-1
Wiring Diagrams	D-1
Exploded Views / Part Numbers	E-1

Type / condition of indicator strips 1st ✓
 This unit requires test strips rated for:
Gravity Displacement Steam Sterilizers
 Test strips must be stored in a cool, dry location.
 Failure to do so will result in faulty readings.
 (Follow all instructions provided with test strips)

Is the sterilizer overloaded? 2nd ✓
 Large loads or heavy linen packs may prevent strips from changing.

Check for pressure leaks. 4th ✓
 Refer to Section B for checkpoints.

Are the correct trays being used? 3rd ✓
 Some trays may prevent proper air flow.
 Be sure trays are designed for this sterilizer.

Temperature Regulator Assy. 5th ✓

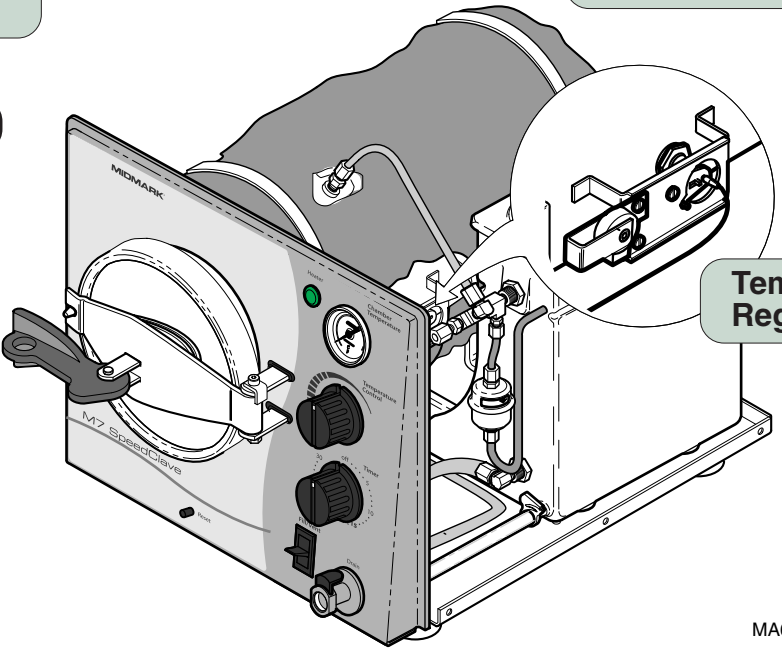
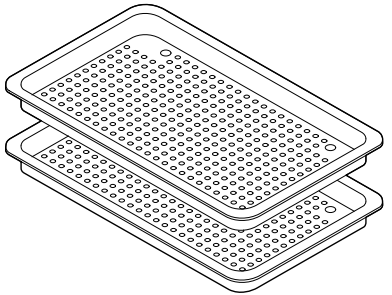

MA672900i

Operation & Troubleshooting

Problem: Timer buzzer does not function.

<u>Refer To:</u>	<u>Page</u>
Operation & Troubleshooting	A-1
Component Testing / Repair	B-1
Access Procedures	C-1
Wiring Diagrams	D-1
Exploded Views / Part Numbers	E-1

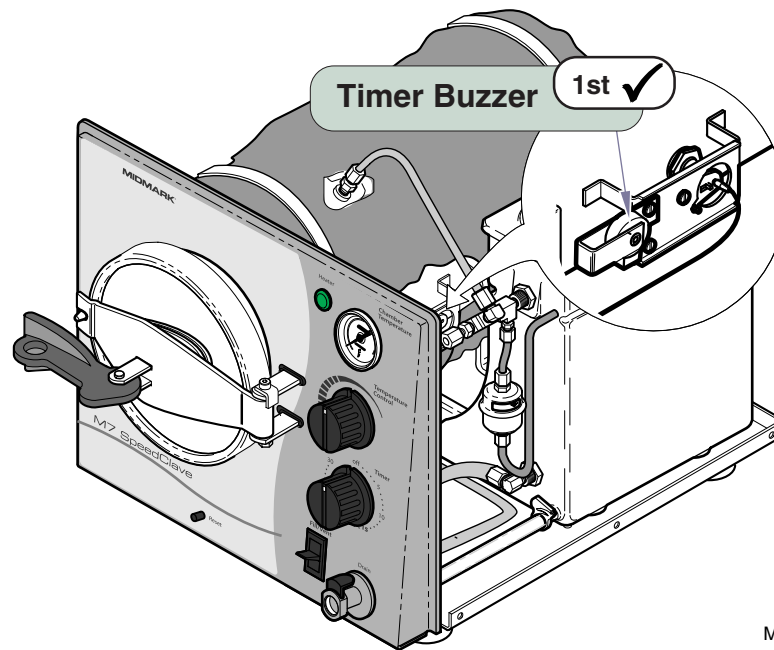

MA672900i

Models: M7 (-020 thru -022)
Serial Numbers: all

Heat-Up / Sterilization

Operation & Troubleshooting

Venting the Chamber

The illustrations show the steam / water flow when venting the chamber. Refer to the following page for a detailed description of this process.

Troubleshooting
[Venting the Chamber]

Problem:	Page
Chamber will not vent:	
- M7 (-020 thru -022)	A-18

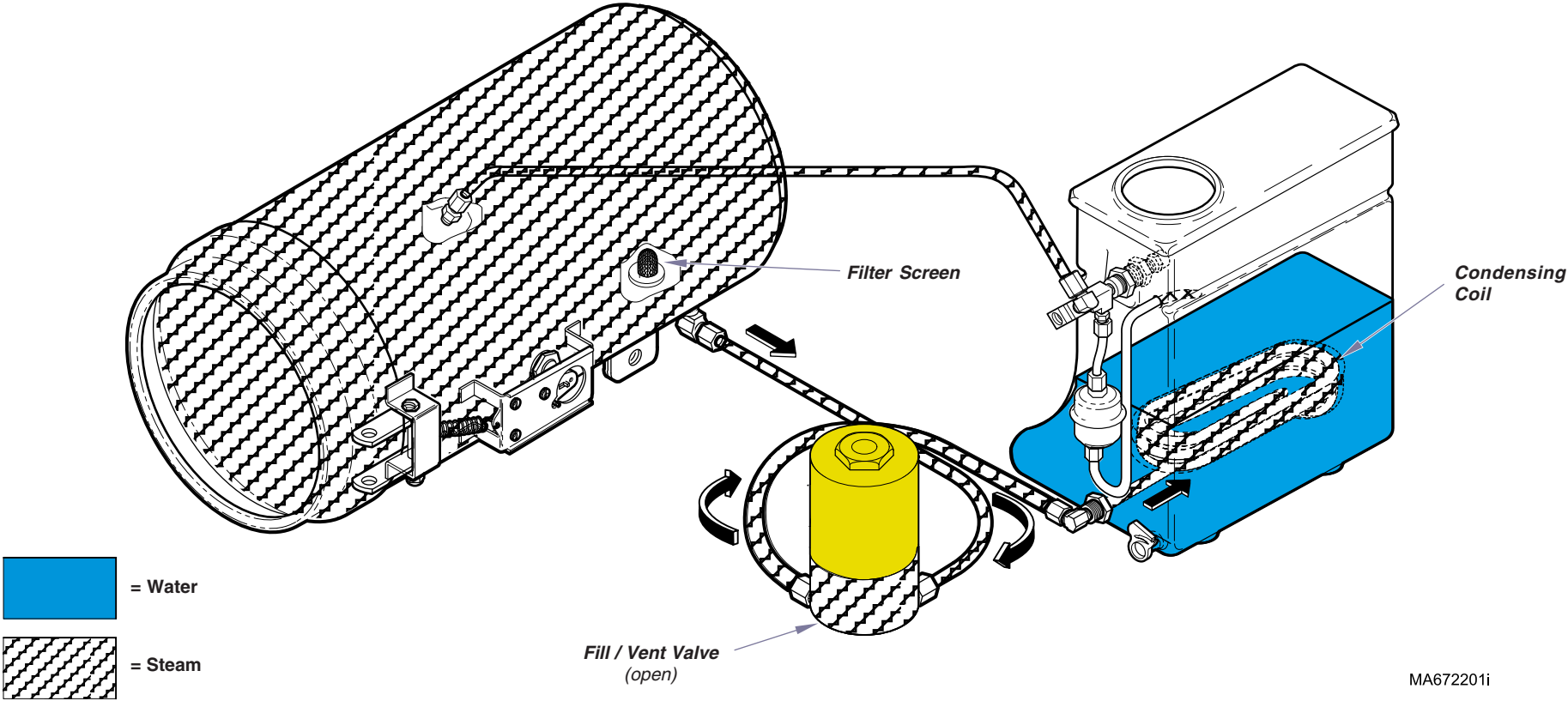

MA672201i

Venting the Chamber

When the Fill / Vent Switch is pressed and held...

Fill / Vent Switch & Valve

Current (line voltage) flows thru the fill/vent switch to the fill/vent valve. When voltage is applied, the (normally closed) fill / vent valve opens. Pressure forces water and steam back into the reservoir thru the valve and the condensing coil. When all of the pressure has been vented, the door will "pop".

*Note: Release the lever when the door "pops".
If the lever is held too long, the chamber will begin to fill.*

When the Fill / Vent Switch is released...

Fill / Vent Switch & Valve

The fill/vent switch opens, stopping the current flow to the fill/vent valve. When voltage is removed, the valve closes.

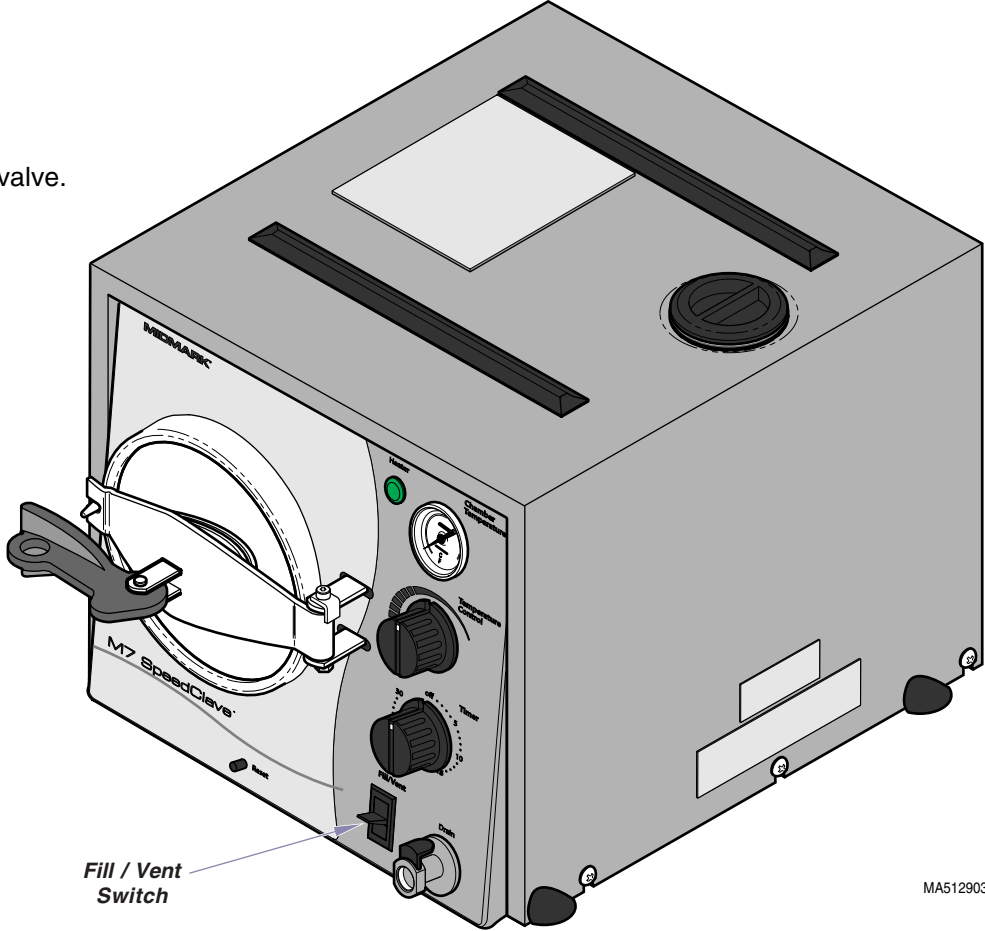

Models:	M7 (-020 thru -022)			
Serial Numbers:	all			

Operation & Troubleshooting

Problem: Chamber will not vent.

Refer To:	Page
Operation & Troubleshooting	A-1
Component Testing / Repair	B-1
Access Procedures	C-1
Wiring Diagrams	D-1
Exploded Views / Part Numbers	E-1

Filter Screen
Clean / replace as necessary.

1st ✓

Fill / Vent Switch 3rd ✓

Fill / Vent Valve & Tubing 2nd ✓
Clean / adjust / replace as necessary.

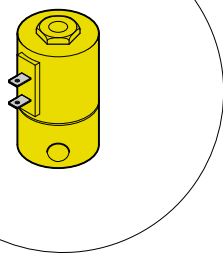

MA673000i

Section B

Testing & Repair

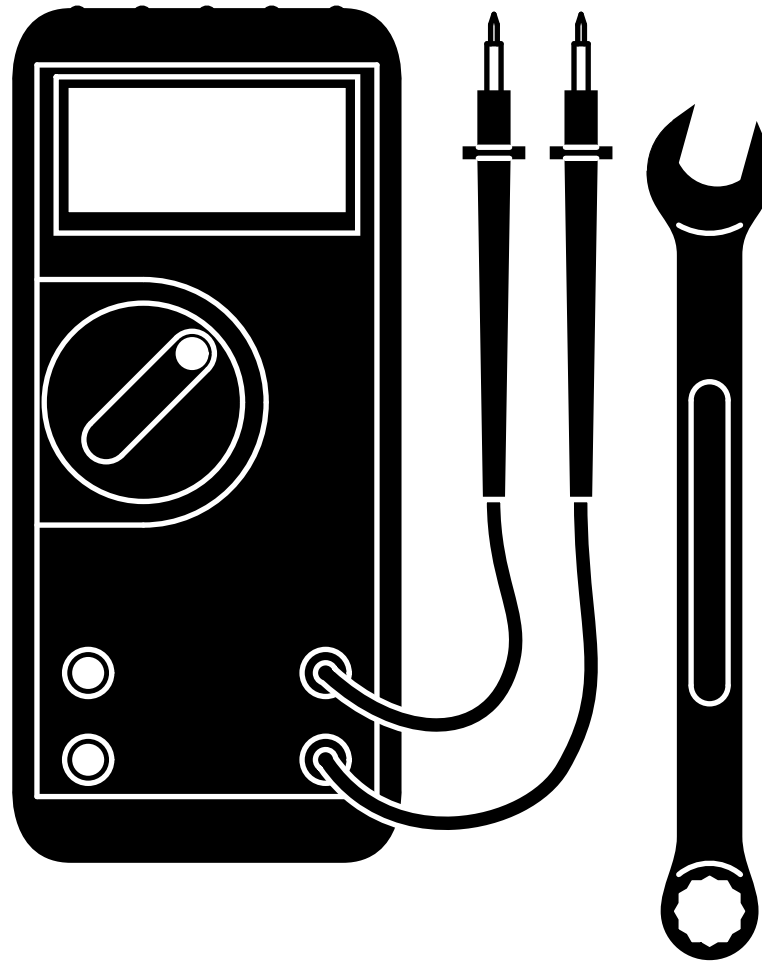

<u>Component / Procedure</u>	<u>Page</u>
Checking For Pressure Leaks	B-2
Fuse [M7 (-020 thru -022) <i>only</i>]	B-3
Bellows	B-4
Fill / Vent Valve:	B-6
Temperature Regulator Assy.	B-10
Heating Element	B-16
Overheat Thermostats	B-20
Pressure Relief Valve	B-23
Timer Assembly	B-24
Timer Buzzer	B-28
Temperature Gauge	B-29
Door Assembly	B-30
Reservoir Tank	B-32
Chamber Assembly	B-34

Component Testing & Repair

Checking for Pressure Leaks

This illustration shows the areas to check for pressure leaks.

Components	Page
Bellows	B-4
Fill / Vent Valve:	B-6
Pressure Relief Valve	B-23
Door Assembly	B-30

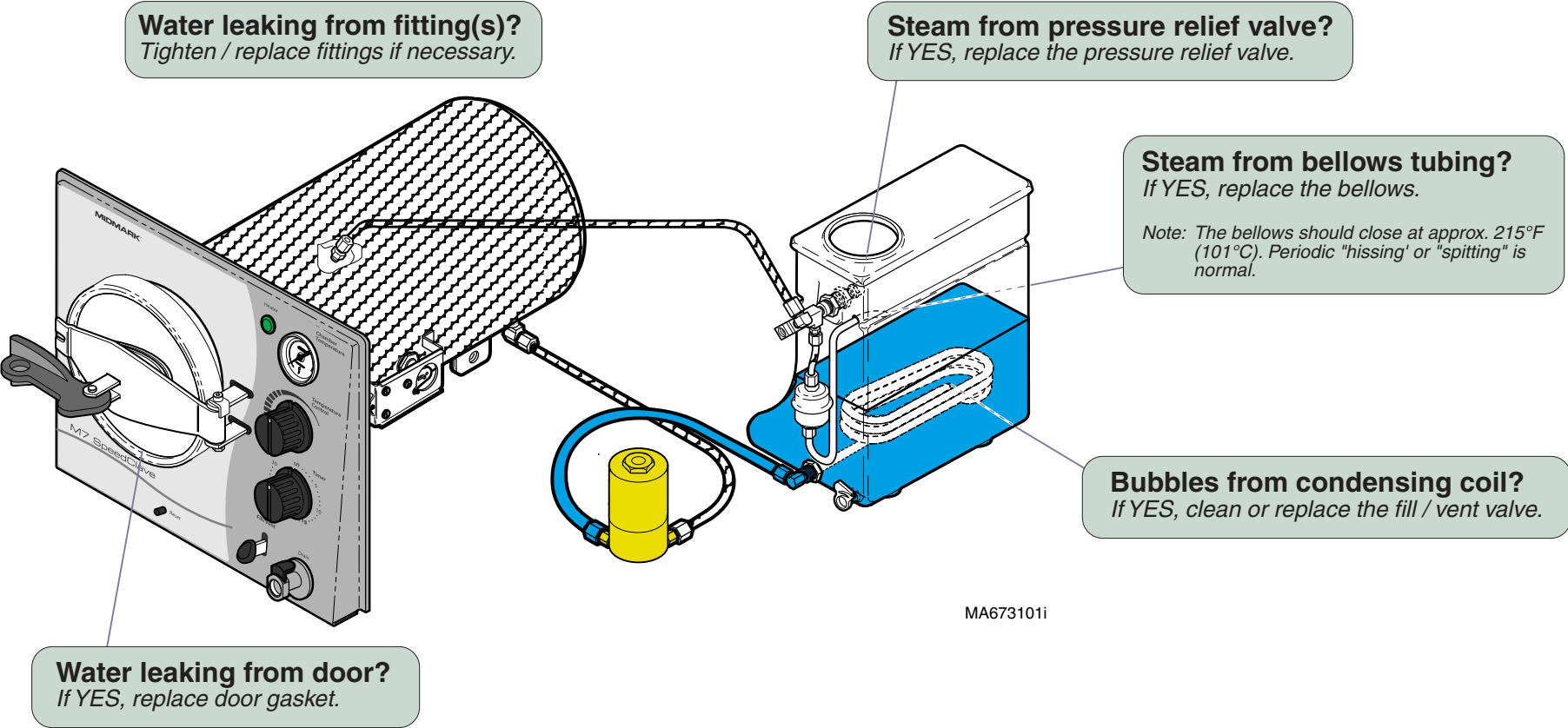

Component Testing & Repair

Fuse

Location

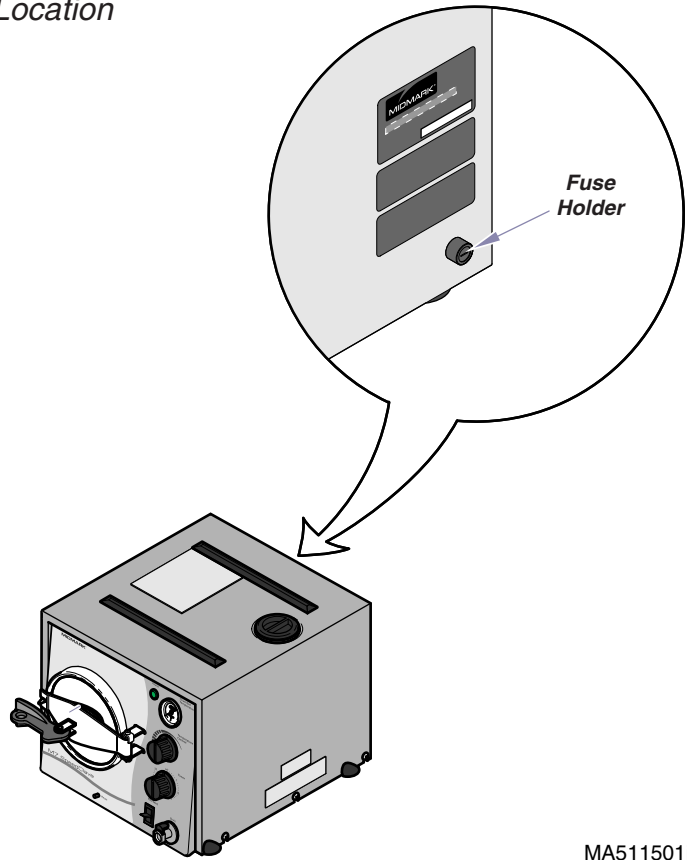

MA511501i

Fuse Ratings:

115V models 12 amp, 250 V, Fast-Acting, 1/4" x 1-1/4"
 230V models 8 amp, 250 V, Fast-Acting, 5mm x 20mm

Fuses	Page
Wiring Diagrams	D-1
Part Numbers	E-13

Fuse Test

Acceptable Range

less than 5 Ω

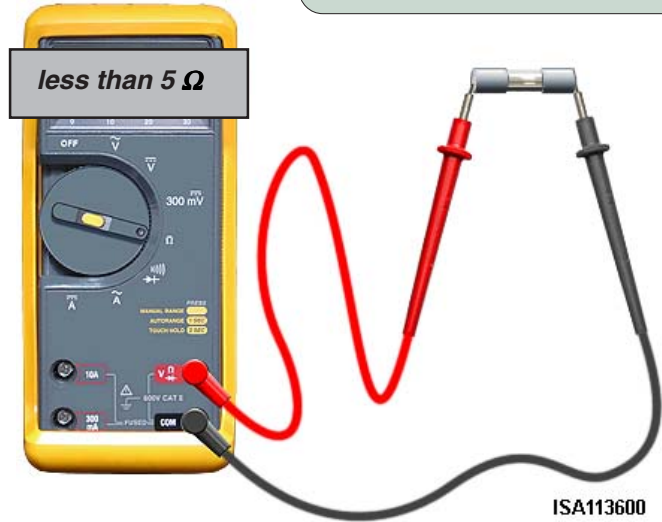

ISA113600

Fuse Test
Step 1: Place meter probes on ends of fuse.
 [Set meter to 200 ohms (Ω)]

Fuse Test
 If reading is OL...
 Replace fuse.
 If reading is within acceptable range...
 Fuse is OK.

Models:	M7 (-020 thru -022)		
Serial Numbers:	all		

Fuse

Component Testing & Repair

Bellows

Location & Function

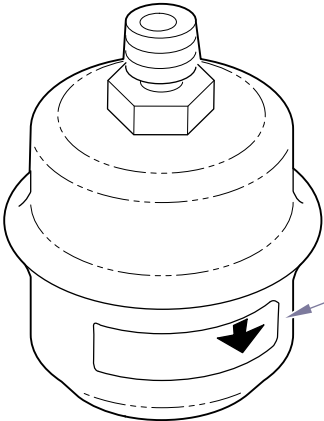

The arrow indicates the direction of flow **toward the reservoir**.

The bellows must be oriented correctly to ensure proper operation.

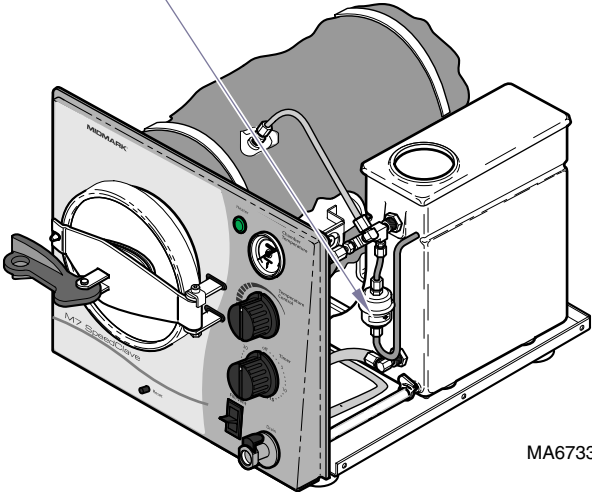

MA673301i

As the water in the chamber begins to boil...

Air & steam are forced out of the chamber, thru the open bellows, and back into the reservoir.

When pure steam begins flowing thru bellows...

The bellows closes allowing pressure to build in the chamber. [Note: The bellows will periodically "hiss" or "spit", this is normal.]

<u>Bellows</u>	<u>Page</u>
Testing - refer to:	
Checking for Pressure Leaks	B-2
Replacement	B-5
Exploded View / Part Numbers	E-10

Bellows - continued

Replacement

Refer to:	Page
Cover Removal.....	C-2

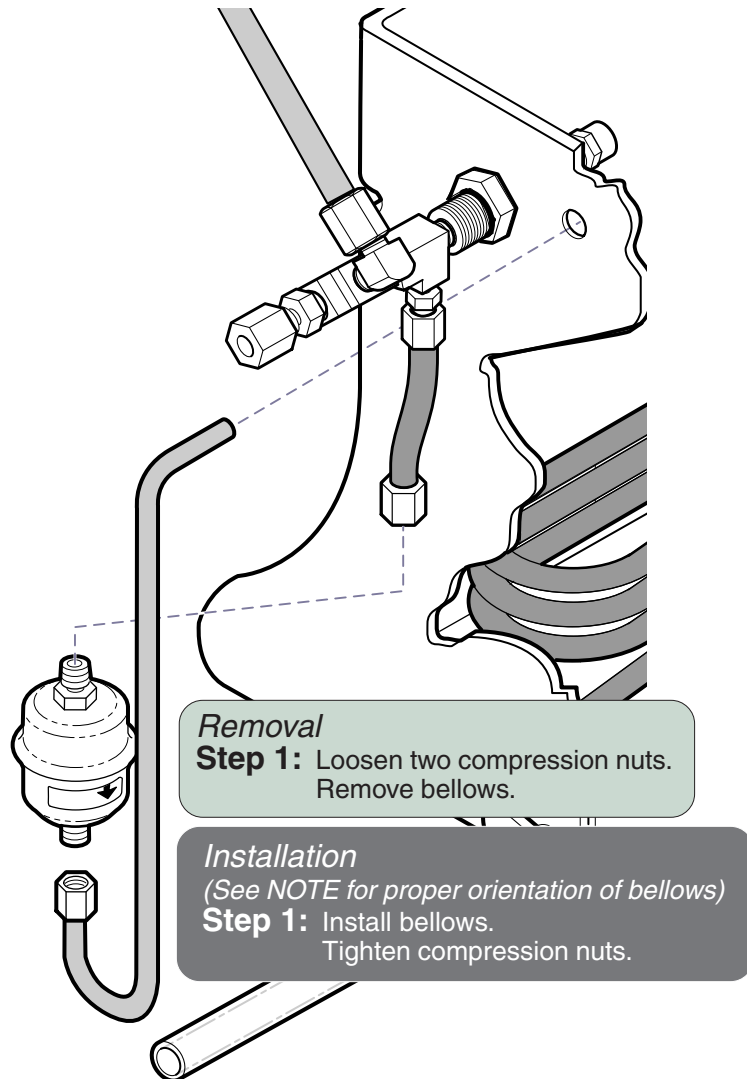

NOTE:

The arrow on the bellows indicates the direction of flow **toward the reservoir**.
The bellows must be oriented correctly to ensure proper operation.

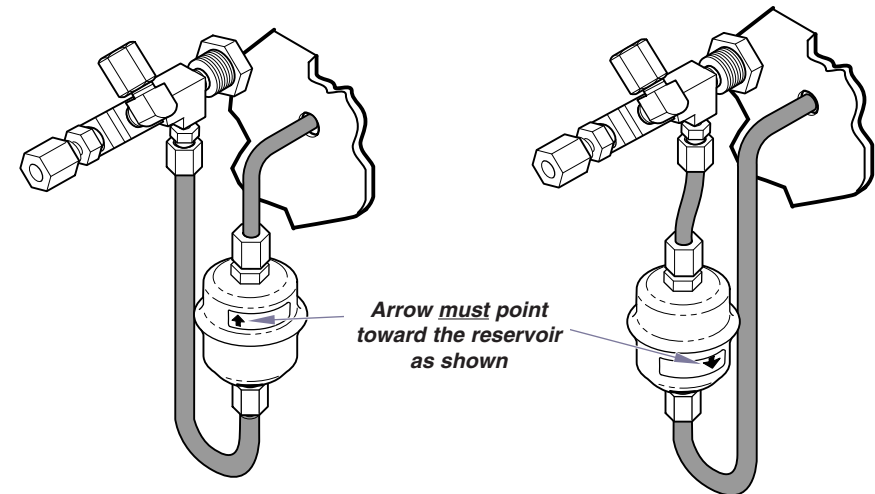

MA673401i

Models: M7 (-020 thru -022)
Serial Numbers: all

Bellows

B-5

Component Testing & Repair

Fill / Vent Valve

Location & Function

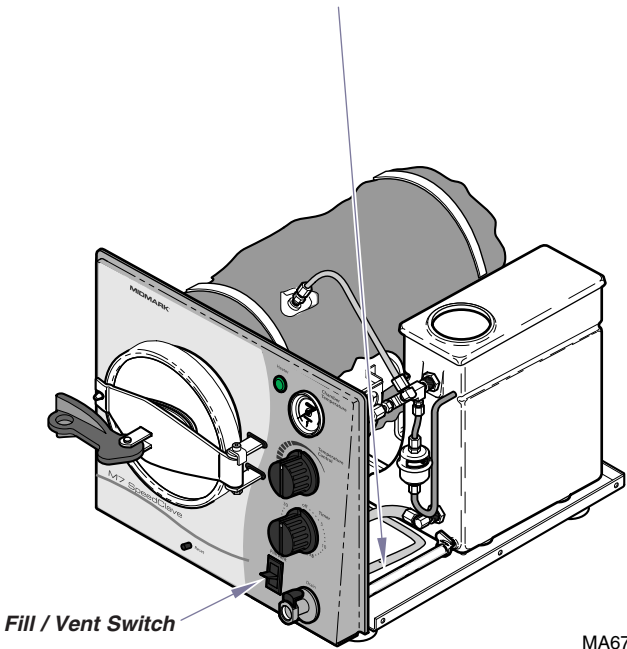
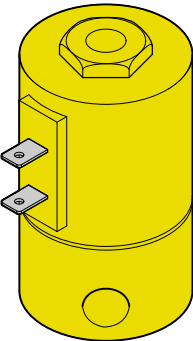

<u>Fill / Vent Valve</u>	<u>Page</u>
Testing - refer to:	
<i>Checking for Pressure Leaks</i>	B-2
<i>Electrical Test</i>	B-7
Replacement	B-8
Disassembly / Cleaning	B-9
Wiring Diagrams	D-1
Exploded View / Part Numbers	E-8

When the fill / vent switch is pressed (no pressure in chamber)...

Current (*line voltage*) flows thru the fill/vent switch to the fill / vent valve. When voltage is applied, the (*normally closed*) fill/vent valve opens. Water from the reservoir flows thru the open valve into the chamber. The valve closes when the switch is released.

When the fill / vent lever is pressed (chamber is pressurized)...

Current (*line voltage*) flows thru the fill/vent switch to the fill/vent valve. When voltage is applied, the (*normally closed*) fill / vent valve opens. Water and steam from the chamber are forced thru the open valve back into the reservoir. When all of the pressure has been released, the door will "pop". The valve closes when the lever is released.

Component Testing & Repair

Fill / Vent Valve - continued

Electrical Test

Refer to: **Page**
Cover Removal C-2

Electrical Test

Step 1: Disconnect wires from valve terminals.

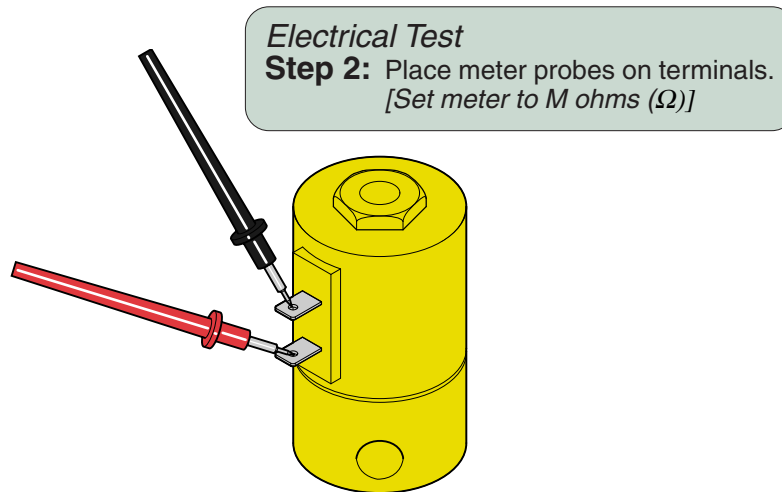

Acceptable Range

115 VAC models: 3.24 to 3.96
230 VAC models: 3.24 to 3.96

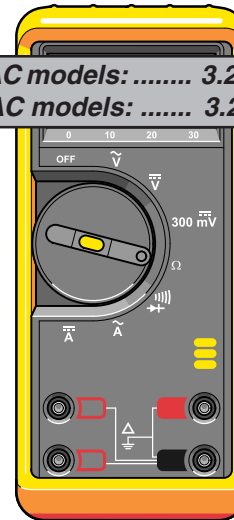

Electrical Test
If reading is out of acceptable range...
Replace valve.

If reading is within acceptable range...
Electrical component of valve is OK.

MA674000i

Models: | M7 (-020 thru -022) |
Serial Numbers: | all |

Fill / Vent Valve

B-7

Component Testing & Repair

Fill / Vent Valve - continued

Replacement

Refer to:	Page
Cover Removal	C-2

Removal
Step 1: Tag and disconnect wires from valve terminals.

Installation
Step 4: Connect wires to valve terminals.

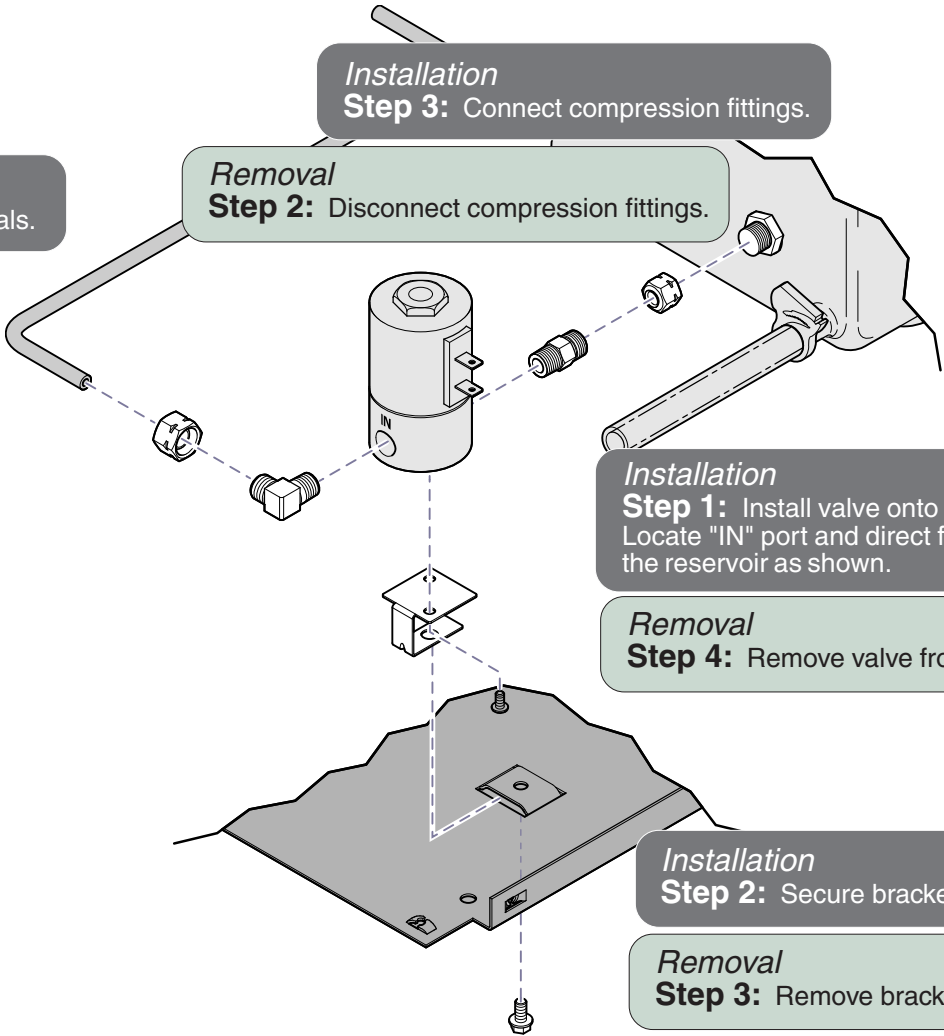

Installation
Step 3: Connect compression fittings.

Removal
Step 2: Disconnect compression fittings.

Installation
Step 1: Install valve onto bracket. Locate "IN" port and direct flow into the reservoir as shown.

Removal
Step 4: Remove valve from bracket.

Installation
Step 2: Secure bracket / valve to base plate.

Removal
Step 3: Remove bracket / valve from base plate.

MA677901i

Fill / Vent Valve - continued

Disassembly / Cleaning

Refer to:	Page
Valve Removal	B-8

Disassembly / Cleaning
Step 1: Remove nut.
Disassemble valve.

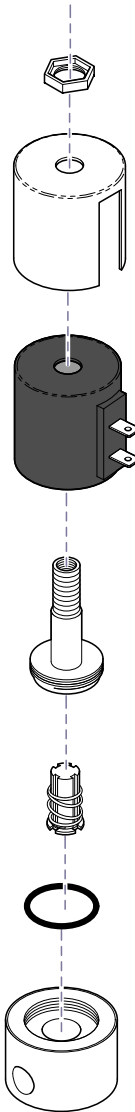

Disassembly / Cleaning
Step 2: Remove any debris.
Inspect components for damage.

MA678000i

Models: M7 (-020 thru -022)			
Serial Numbers: all			

Fill / Vent Valve

Component Testing & Repair

Temperature Regulator Assembly

Location & Function

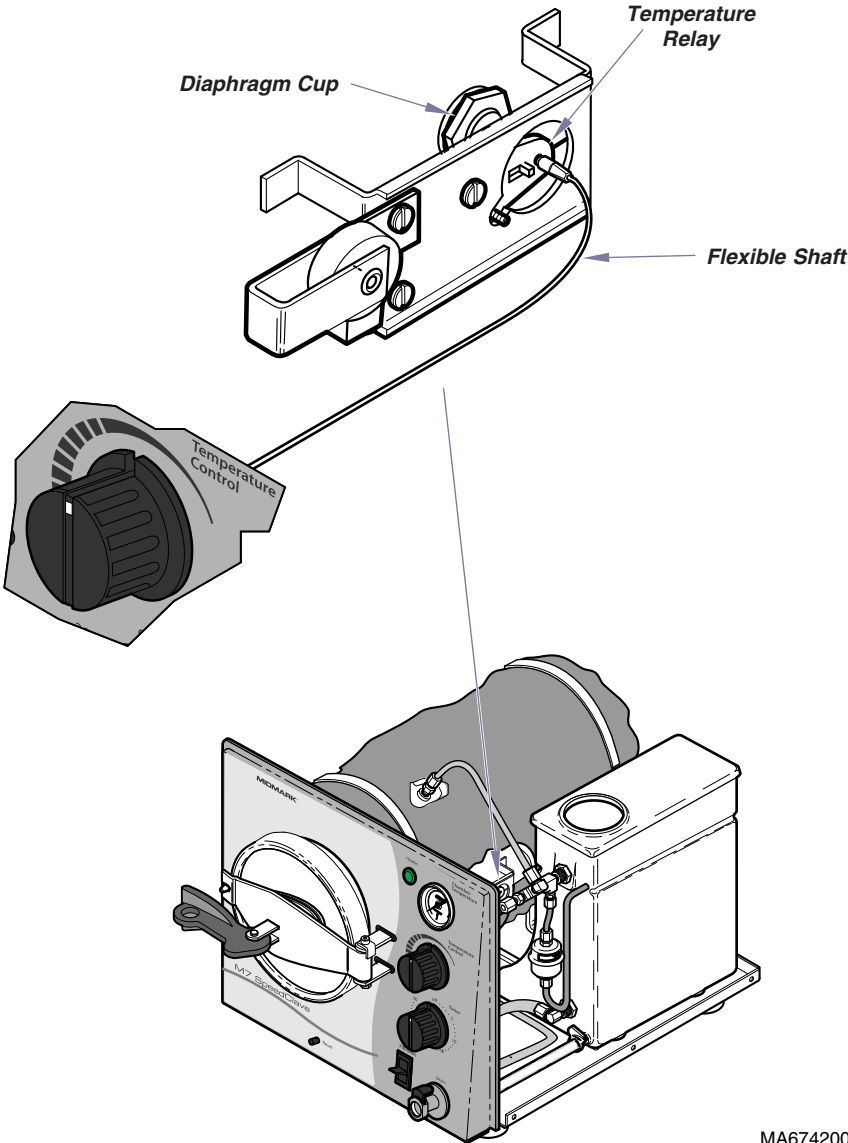

MA674200i

Temp. Regulator Assy.	Page
Troubleshooting	B-11
Temperature Relay:	
Adjustment	B-12
Removal	B-13
Installation	B-14
Diaphragm Cup Replacement	B-15
Wiring Diagrams	D-1
Exploded View / Part Numbers	E-6

When the Temperature Control knob is adjusted...
 The flexible shaft rotates, increasing or decreasing the distance between the relay contacts. This adjusts the point (*i.e. temperature*) at which the relay contacts will open & close*.

As the temperature & pressure inside the chamber increase...
 The diaphragm cup expands, pushing the relay contacts apart. When the relay contacts are open, the heating element is de-energized.

As the temperature & pressure inside the chamber decrease...
 The diaphragm cup contracts, allowing the relay contacts to close. When the relay contacts are closed, the heating element is energized.

Temperature Regulator Assembly - continued

Troubleshooting

Refer to:	Page
Relay Adjustment	B-12
Relay Removal	B-13
Diaphragm Cup Replacement	B-15

Sterilizer shuts down before timer setting expires...

Required action: Inspect relay.
(If contacts are corroded or "fused" together - replace relay)

Inspect diaphragm cup.
(If water / steam is leaking from this area, replace diaphragm cup)

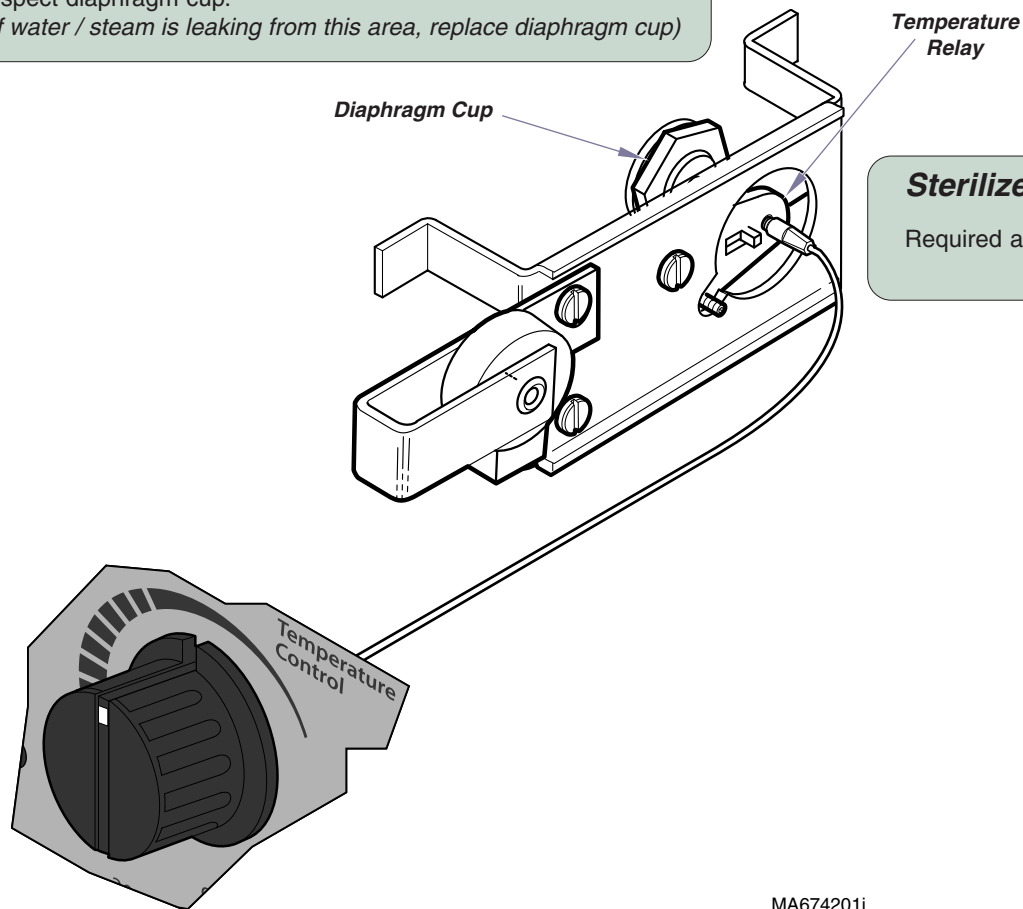

Sterilizer does not reach desired temperature...

Required action: Perform *Relay Adjustment*.
Replace relay if necessary.

MA674201i

Models: | M7 (-020 thru -022) |
Serial Numbers: | all |

Temperature Regulator
Assembly

Component Testing & Repair

Temperature Regulator Assembly - continued

Relay Adjustment

Refer to:	Page
Cover Removal.....	C-2

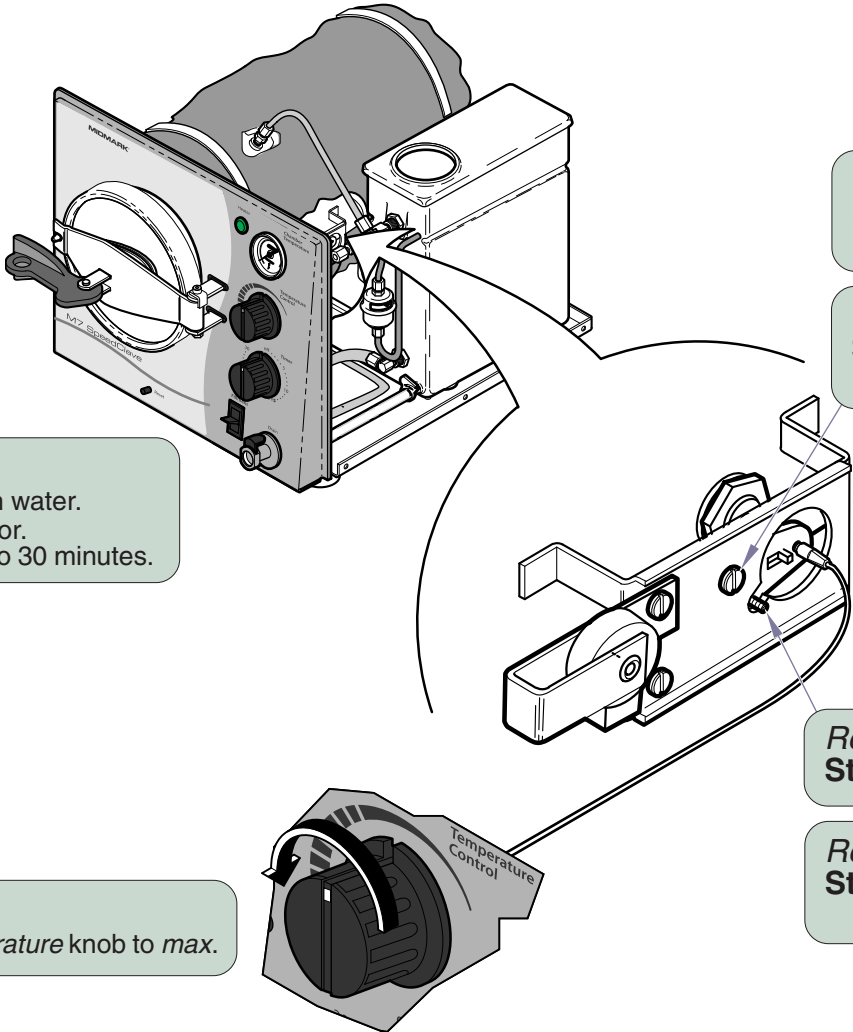

Relay Adjustment
Step 1: Fill chamber with water.
Close & latch door.
Set *Timer* knob to 30 minutes.

Relay Adjustment
Step 4: Allow chamber to reach its max. temperature [$>270^{\circ}\text{F}$ (132°C)].

Relay Adjustment
Step 5: Adjust screw until temperature gauge reads slightly above 270°F (132°C).

Relay Adjustment
Step 3: Loosen setscrew 2-3 turns.

Relay Adjustment
Step 6: Adjust setscrew until temperature gauge reads $270\text{-}271^{\circ}\text{F}$ ($131\text{-}132^{\circ}\text{C}$).

Relay Adjustment
Step 2: Turn *Temperature* knob to max.

MA674400i

Temperature Regulator Assembly - continued

Relay Removal

Refer to: **Page**
Cover Removal C-2

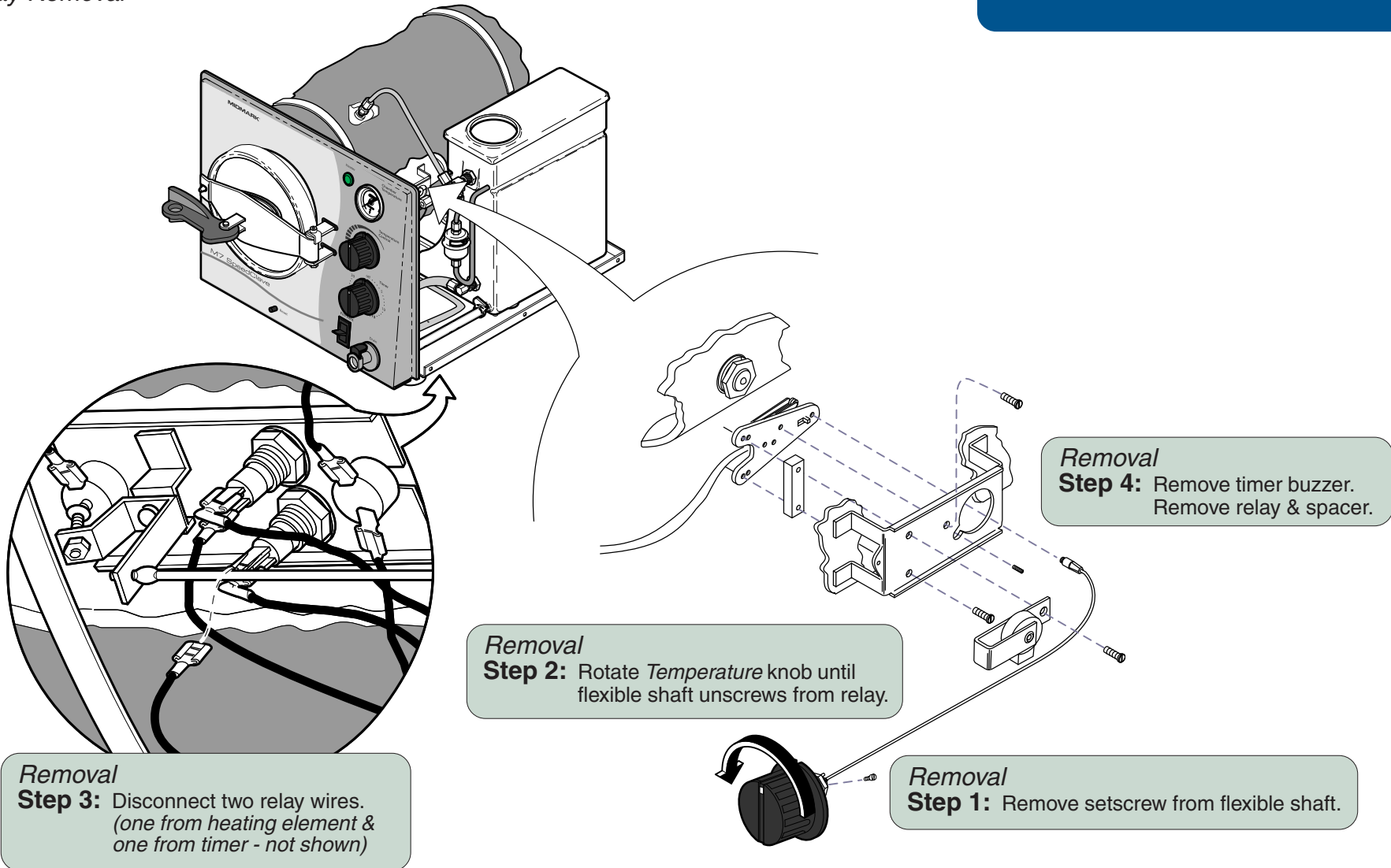

MA674500i

Models: | M7 (-020 thru -022) |
Serial Numbers: | all |

**Temperature Regulator
Assembly**

Component Testing & Repair

Temperature Regulator Assembly - continued

Relay Installation

Refer to:	Page
Relay Removal	B-13
Relay Adjustment	B-12

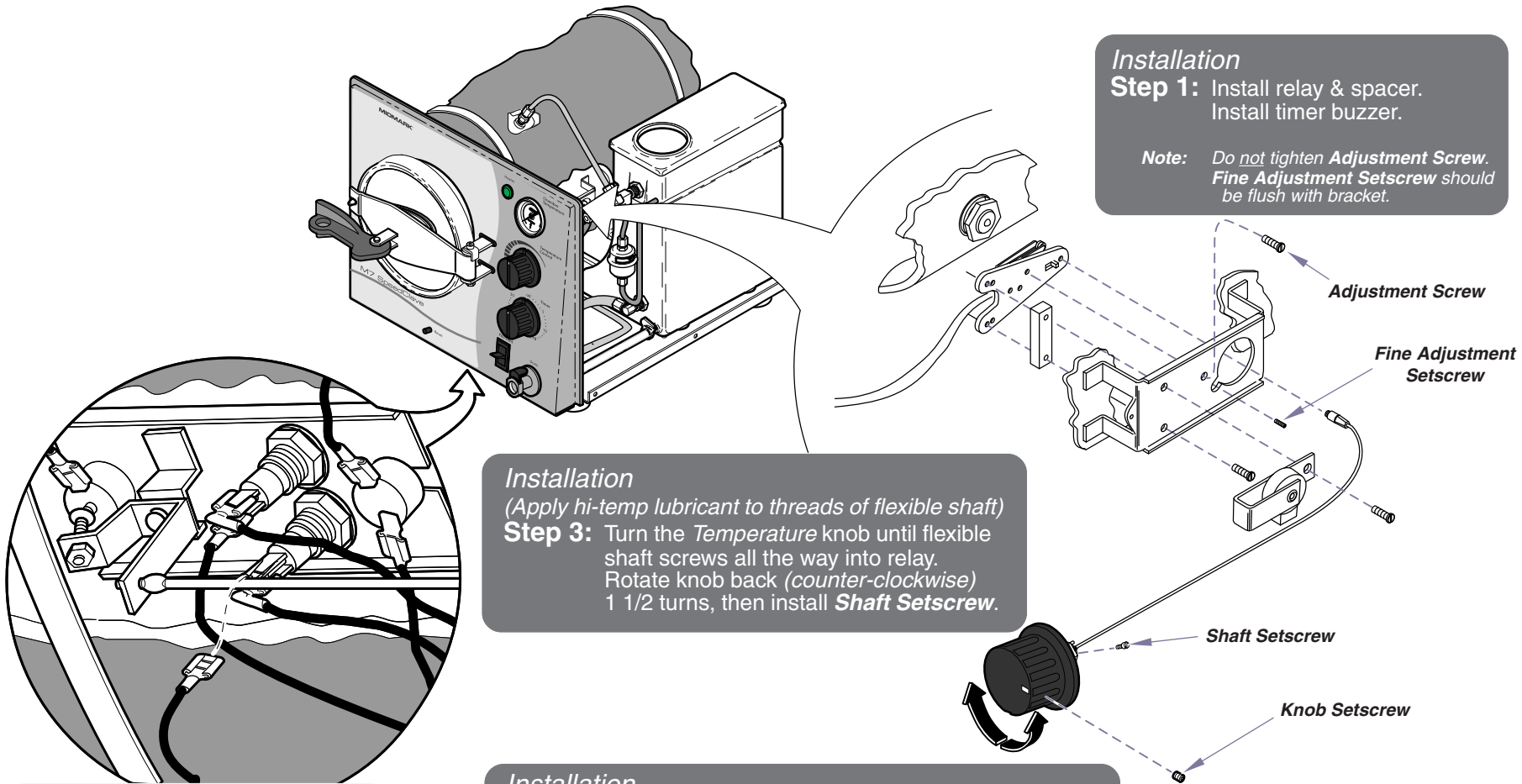

Installation
Step 1: Install relay & spacer.
 Install timer buzzer.

Note: Do **not** tighten **Adjustment Screw**.
Fine Adjustment Setscrew should be flush with bracket.

Installation
 (Apply hi-temp lubricant to threads of flexible shaft)
Step 3: Turn the *Temperature* knob until flexible shaft screws all the way into relay. Rotate knob back (counter-clockwise) 1 1/2 turns, then install **Shaft Setscrew**.

Installation
Step 2: Connect two relay wires. (one to heating element & one to timer - not shown)

Installation
Step 4: Turn the *Temperature* knob counter-clockwise until it hits the stop. Hold knob in place, then loosen **Knob Setscrew**. Rotate knob so that white mark is at 3:00 position, then tighten knob setscrew.

Installation
Step 5: Perform *Relay Adjustment*.

MA674501i

Temperature Regulator Assembly - continued

Diaphragm Cup Replacement

Removal

Step 1: Remove relay.

Installation

Step 3: Install relay.

Removal

Step 2: Remove nut & lockwasher.

Installation

Step 2: Install lockwasher & nut.

Installation

Step 1: Install gasket onto diaphragm cup.
Install diaphragm cup.

Removal

Step 3: Remove diaphragm cup
Remove gasket from diaphragm cup.

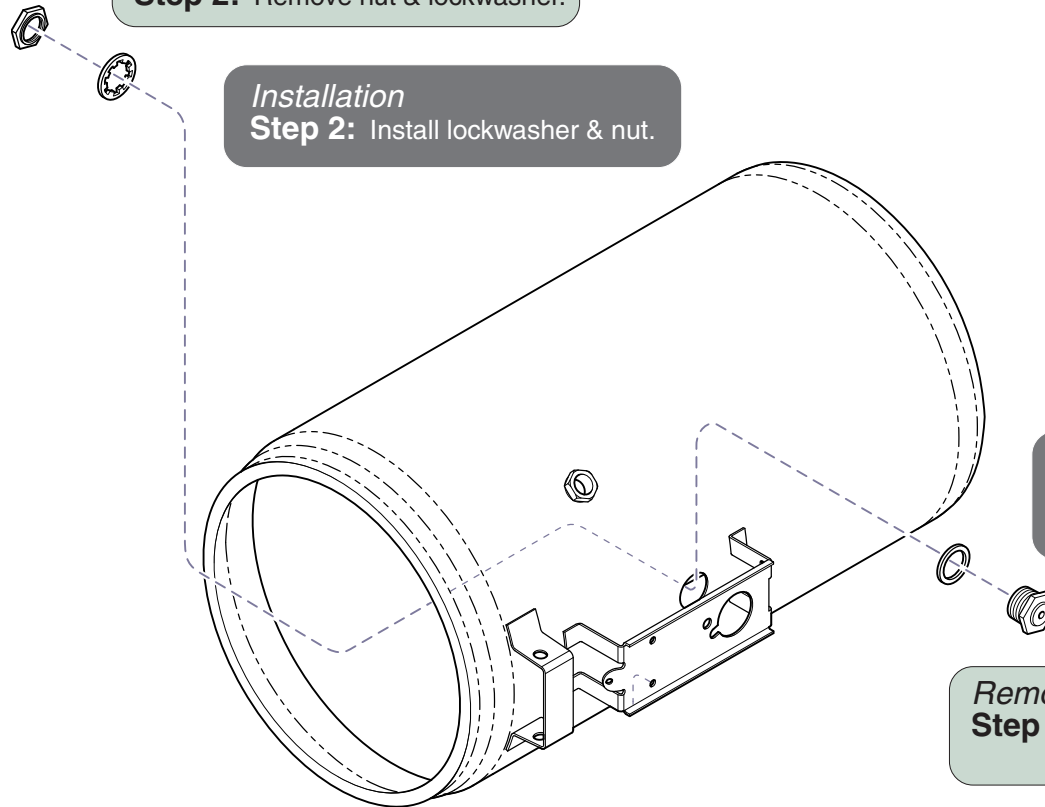

MA674700i

Refer to:

Page

Relay Removal B-13

Relay Installation B-14

Models: | M7 (-020 thru -022) |
Serial Numbers: | all |

**Temperature Regulator
Assembly**

Component Testing & Repair

Heating Element

Location & Function

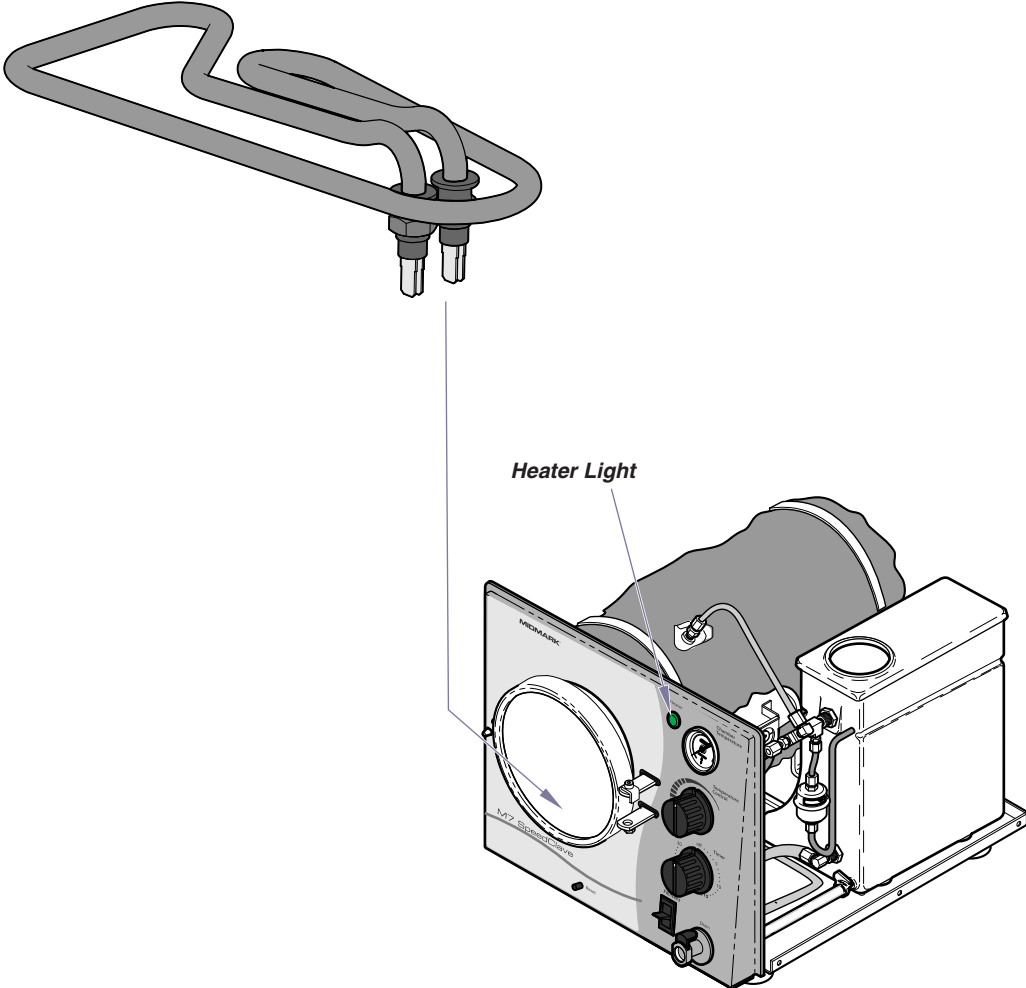

<u>Heating Element</u>	<u>Page</u>
Resistance Test	B-17
Replacement	B-18
Wiring Diagrams	D-1
Exploded View / Part Numbers	E-12

When the timer is turned ON...

The timer supplies current to the temperature relay. If the chamber temperature is lower than the temperature knob setting*, the relay contacts are closed. When these contacts are closed, current flows thru the relay to energize the heating element and the heater light.

When the chamber temperature reaches the temperature knob setting, the relay contacts open, and voltage is removed from the heating element & heater light.

[* The minimum temperature knob setting is approx. 220°F (104°C)]

When the timer is OFF...

Timer contacts to the temperature relay open, stopping the current flow to the heater light & heating element.

MA674800i

Refer to:	Page
Cover Removal.....	C-2

Heating Element - continued

Resistance Test

Resistance Test
Step 1: Disconnect wires from heating element terminals.

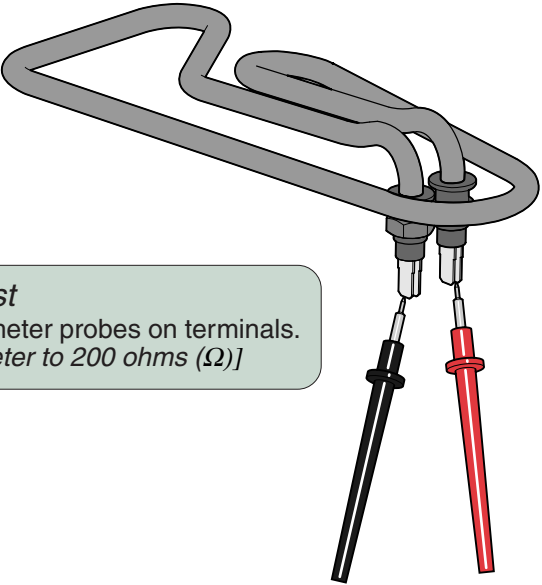

Resistance Test
Step 2: Place meter probes on terminals.
[Set meter to 200 ohms (Ω)]

Acceptable Range

- 100 VAC models 8 to 10
- 115 VAC models: 11 to 13
- 230 VAC models: 45 to 51

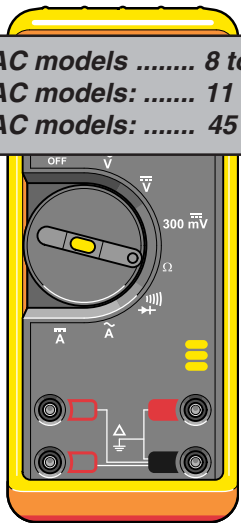

Resistance Test
If reading is out of acceptable range...
Replace heating element.

If reading is within acceptable range...
Heating element is OK.

MA674900i

Models: M7 (-020 thru -022)			
Serial Numbers: all			

Component Testing & Repair

Heating Element - continued

Replacement

Refer to:	Page
Cover Removal	C-2
Wiring Diagrams	D-1

Removal
Step 1: Disconnect power to sterilizer.
Drain all water from reservoir.

Removal
Step 2: Remove inspection cover.

Installation
Step 4: Install inspection cover.

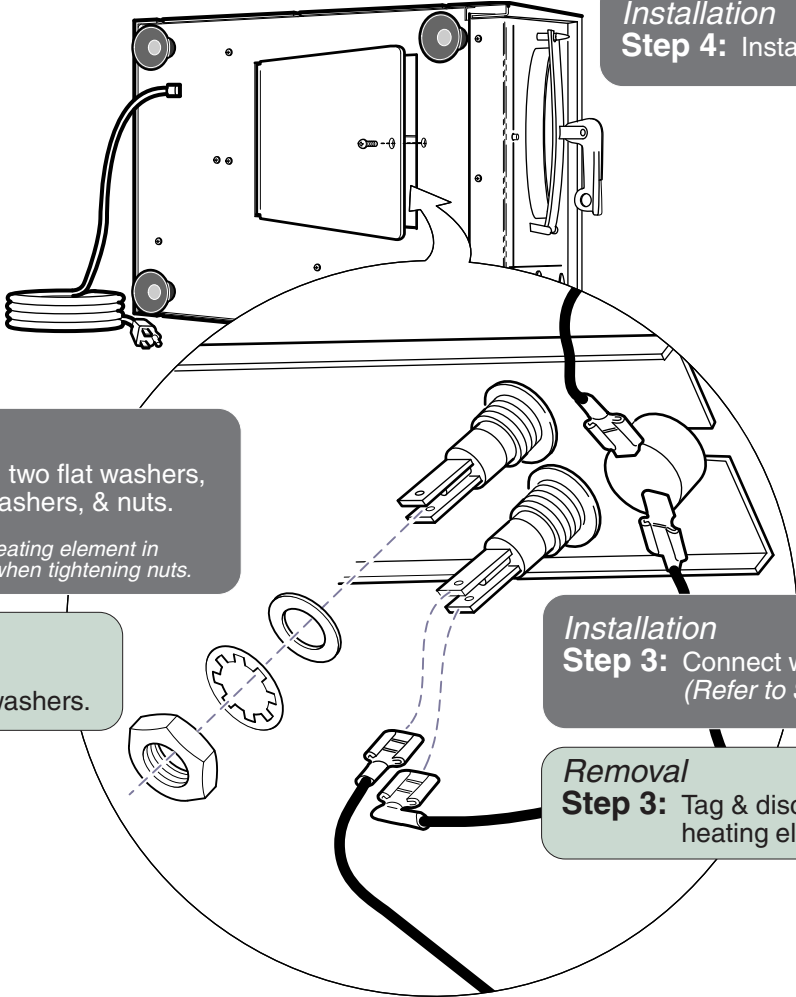

Installation
Step 2: Install two flat washers, lockwashers, & nuts.
Note: Hold heating element in place when tightening nuts.

Removal
Step 4: Remove two nuts, lockwashers & flat washers.

Installation
Step 3: Connect wires to heating element terminals. (Refer to **Section D** for wiring diagrams)

Removal
Step 3: Tag & disconnect wires from heating element terminals.

MA675000i

Heating Element - continued

Replacement - continued

Refer to:	Page
Cover Removal	C-2

Removal
Step 5: Remove heating element.
Remove gaskets from terminal posts.

Installation
Step 1: Install gaskets onto terminal posts.
Install spacers or spacer bracket*.
Insert terminal posts thru chamber & thermostat bracket.

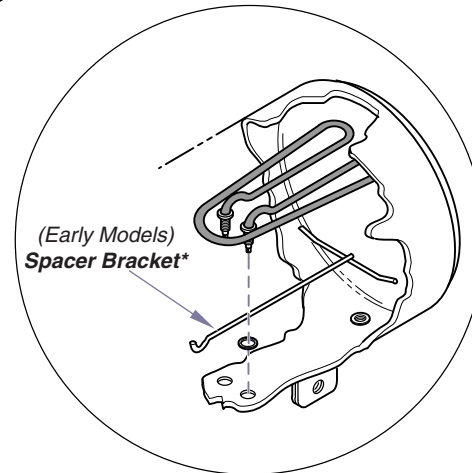
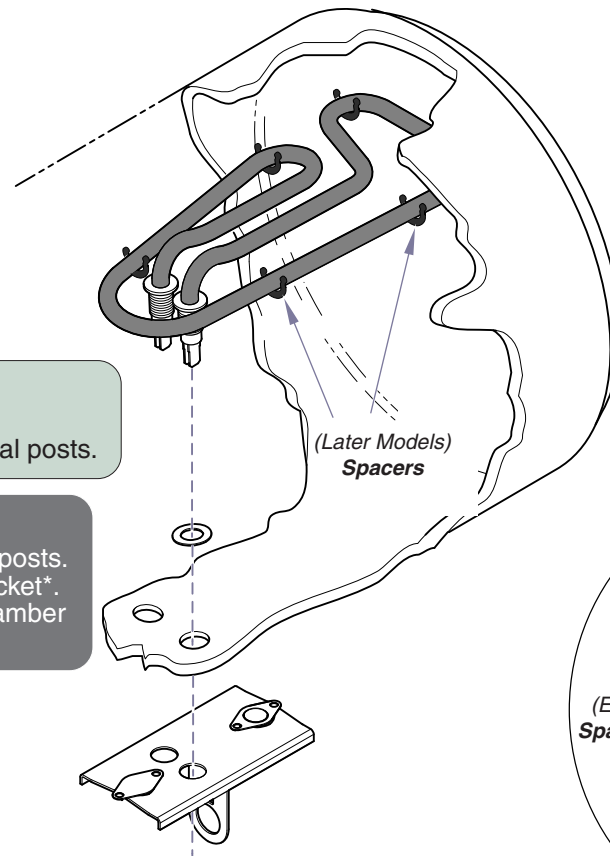

* Spacer Bracket must be installed above gaskets to prevent leaking.

Models: M7 (-020 thru -022)			
Serial Numbers: all			

MA675200i
Heating Element

Component Testing & Repair

Overheat Thermostats

Location & Function

<u>Overheat Thermostats</u>	<u>Page</u>
Resistance Test	B-21
Replacement	B-22
Wiring Diagrams	D-1
Exploded View / Part Numbers	E-12

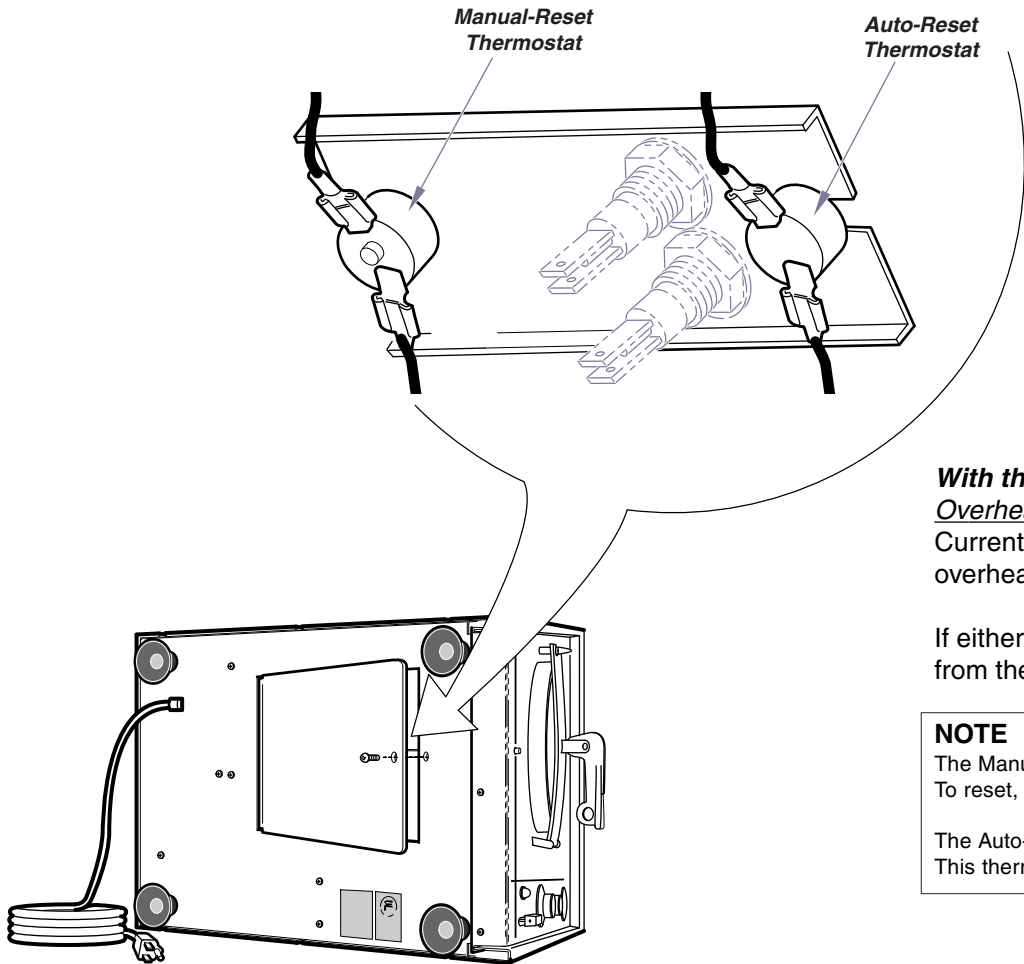

With the power cord properly connected...

Overheat Thermostats
 Current (115 / 230 VAC) continuously flows thru the two (normally closed) overheat thermostats. This current supplies power to the timer.

If either thermostat opens (overheat or malfunction), voltage is removed from the timer until the thermostat is reset or replaced.

NOTE
 The Manual-Reset Thermostat contacts open at approximately 285°F (140°C). To reset, allow unit to cool, then press RESET button on front of unit.
 The Auto-Reset Thermostat contacts open at approximately 295°F (146°C). This thermostat automatically resets when the unit cools to approx. 265°F (129°C).

MA675300i

Component Testing & Repair

Overheat Thermostats - continued

Resistance Test

Refer to:	Page
Cover Removal	C-2

Attention!
Inspect thermostat for physical damage (ex. cracked plastic).
If damage is apparent, replace thermostat

Resistance Test
Step 1: Disconnect wires from thermostat terminals.



Resistance Test
Step 2: Place meter probes on terminals.
[Set meter to 200 ohms (Ω)]

Acceptable Reading

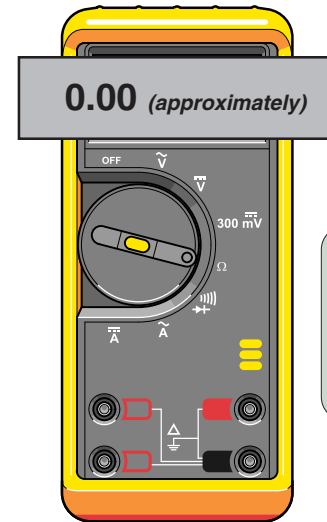

Resistance Test
If reading is (approximately) 0.00 ...
Thermostat is good.
If reading is OL...
Replace thermostat.

Models:	M7 (-020 thru -022)		
Serial Numbers:	all		

Overheat Thermostats

Component Testing & Repair

Overheat Thermostats - continued

Replacement

Refer to: **Page**
 Wiring Diagrams D-1

Removal
Step 1: Disconnect power to sterilizer.
 Drain all water from reservoir.

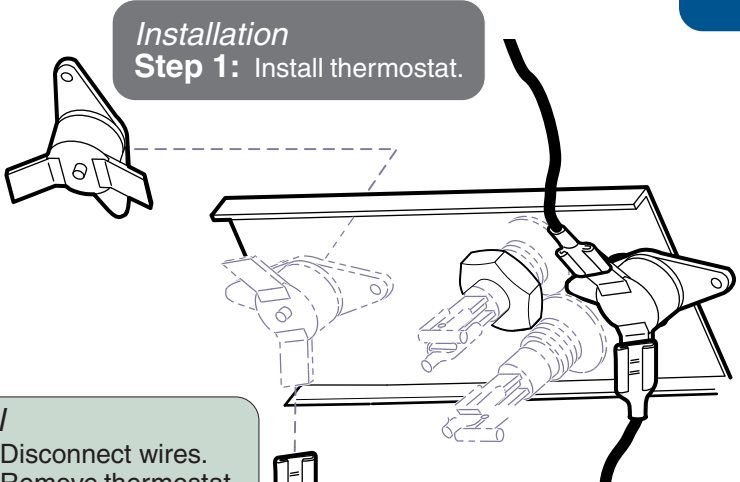

Removal
Step 4: Disconnect wires.
 Remove thermostat.

Removal
Step 3: Loosen two nuts on heating element posts.

Installation
Step 3: Connect wires.

Installation
Step 2: Tighten two nuts.

Removal
Step 2: Remove inspection cover.

Installation
Step 4: Install inspection cover.

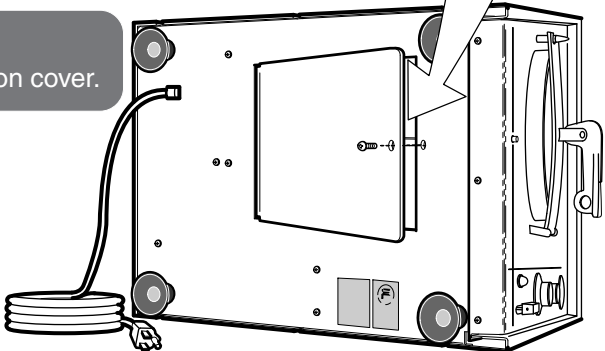

MA675500i

Component Testing & Repair

Pressure Relief Valve

Location & Function

If the pressure in the chamber exceeds 34 psi (234kPa)...
The pressure relief valve opens to prevent unsafe conditions.

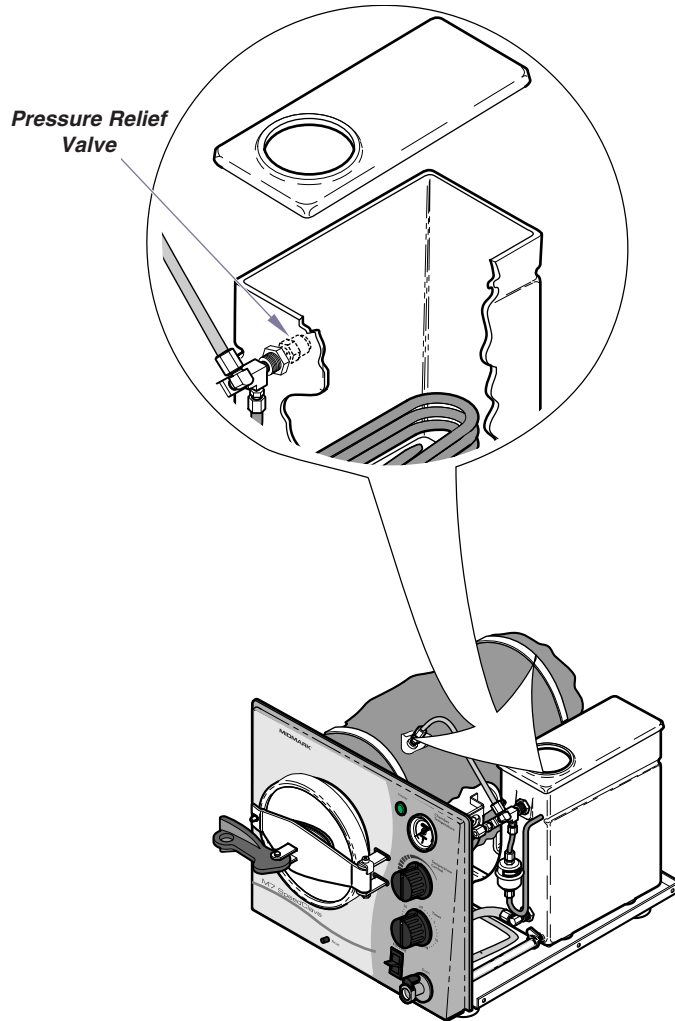

Pressure Relief Valve

Page

Testing - refer to:

Checking for Pressure Leaks B-2

Exploded View / Part Numbers E-7

Replacement

Installation

Step 1: Apply hi-temp sealant to valve threads.
Install valve.

Removal

Step 1: Unscrew pressure relief valve.

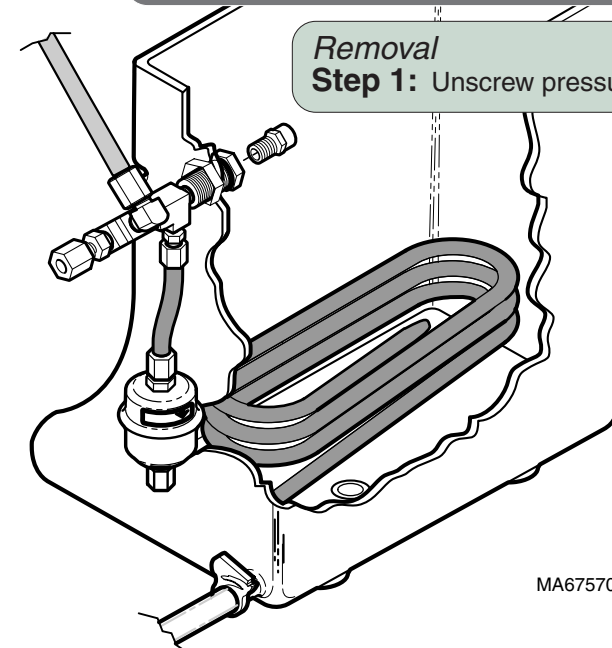

MA675700i

Models: M7 (-020 thru -022)
Serial Numbers: all

Pressure Relief Valve

B-23

Component Testing & Repair

Timer

Location & Function

Timer	Page
Supply Voltage Test	B-25
Output Voltage Test	B-26
Replacement	B-27
Wiring Diagrams	D-1
Exploded View / Part Numbers	E-11

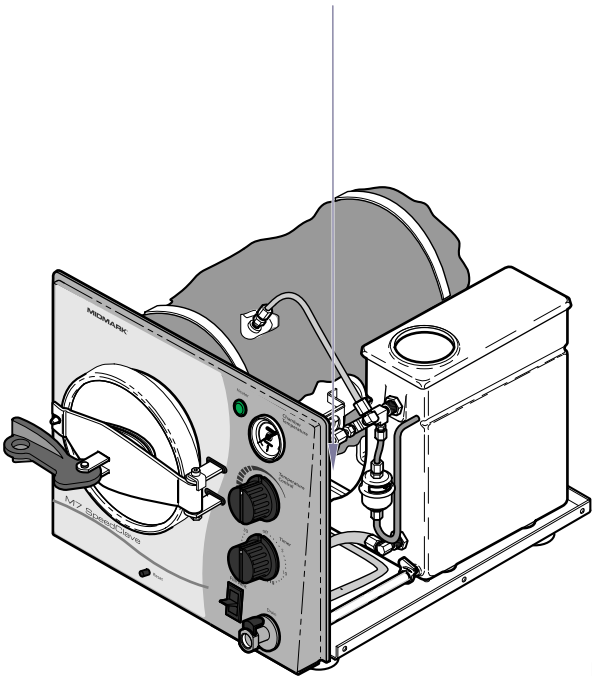
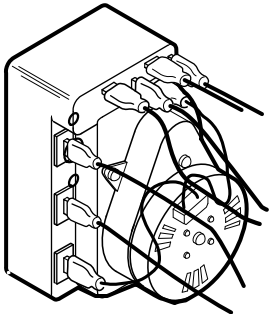

NOTE
Current is supplied to the timer thru the two overheat thermostats.

When the timer is turned ON...
The timer contacts to the timer motor & the temperature relay close, and voltage is supplied to these components. When voltage is applied to the timer motor, the time setting counts down.
(The contacts to the timer buzzer remain open).

When the timer setting expires...
The timer contacts to the temperature relay open, stopping the current flow to the relay.

The timer contacts to the buzzer close for one minute. Current flows to the buzzer, resulting in a audible signal. After one minute, the contacts to the timer motor & the buzzer open, stopping the current flow to these two components.

MA675800i

Component Testing & Repair

Timer - continued

Supply Voltage Test



Caution

This test must be performed with the power cord connected.

Refer to:

Page

Cover Removal C-2
 Output Voltage Test B-28

Supply Voltage Test

Step 1: Place meter probes on terminals as shown.
 [Set meter to VAC]

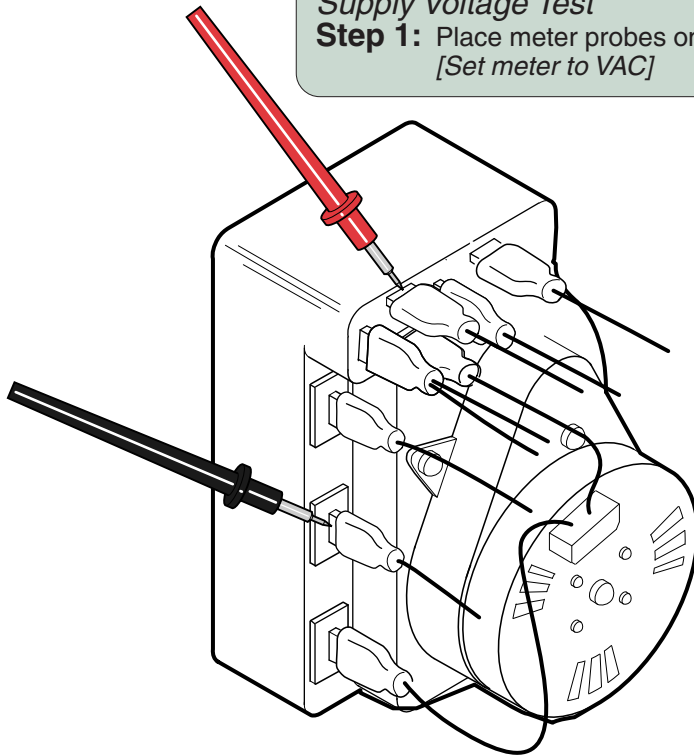

Acceptable Range

line voltage (115 / 230 VAC $\pm 10\%$)

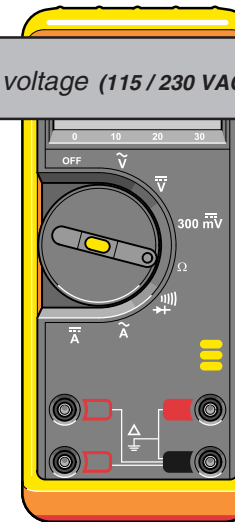

MA676000i

Supply Voltage Test
If reading is within range...
 Perform Output Voltage Test.

If reading is out of range...
 Check voltage supply.
 (overheat thermostats, fuse, etc.)

Models: | M7 (-020 thru -022) |
Serial Numbers: | all |

Timer

Component Testing & Repair

Timer - continued

Output Voltage Test (perform Supply Voltage Test first)

Refer to:	Page
Cover Removal	C-2
Supply Voltage Test	B-25



Caution

This test must be performed with the power cord connected.

Voltage to Temp. Relay

Step 1: Turn timer knob to 10 minutes.
Place meter probes on terminals as shown.
[Set meter to VAC]

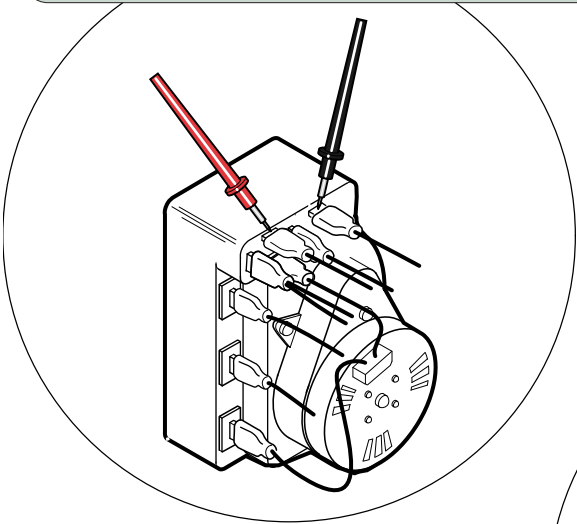

Voltage to Timer Motor

Step 1: Turn timer knob to 10 minutes.
Place meter probes on terminals as shown.
[Set meter to VAC]

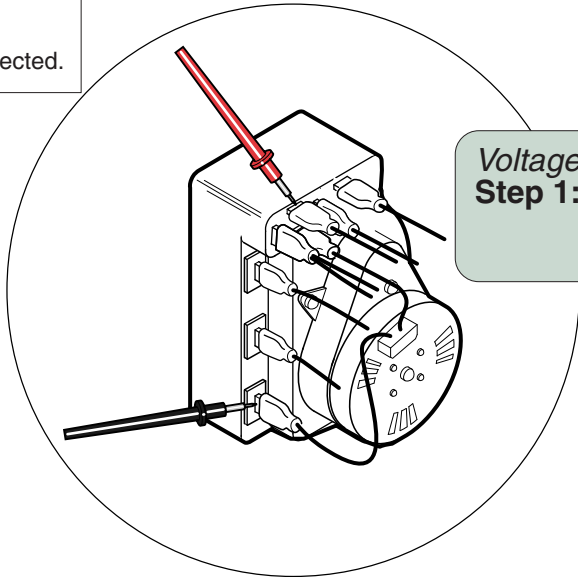

Acceptable Range

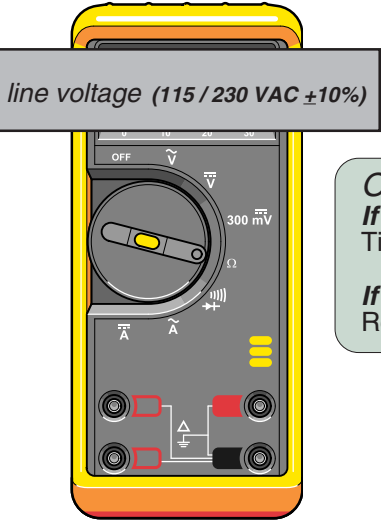

Output Voltage Test
If reading is within range...
Timer is functioning properly.

If reading is out of range...
Replace timer.

MA675900i

Voltage to Timer Buzzer

Step 1: Turn timer knob to 1 minute (or less).
Place meter probes on terminals as shown.
[Set meter to VAC]

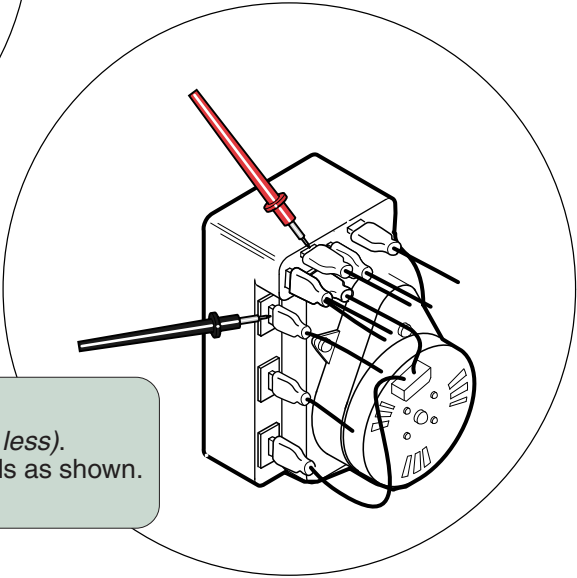

Component Testing & Repair

Timer - continued

Replacement

Refer to:	Page
Cover Removal	C-2
Wiring Diagrams	D-1

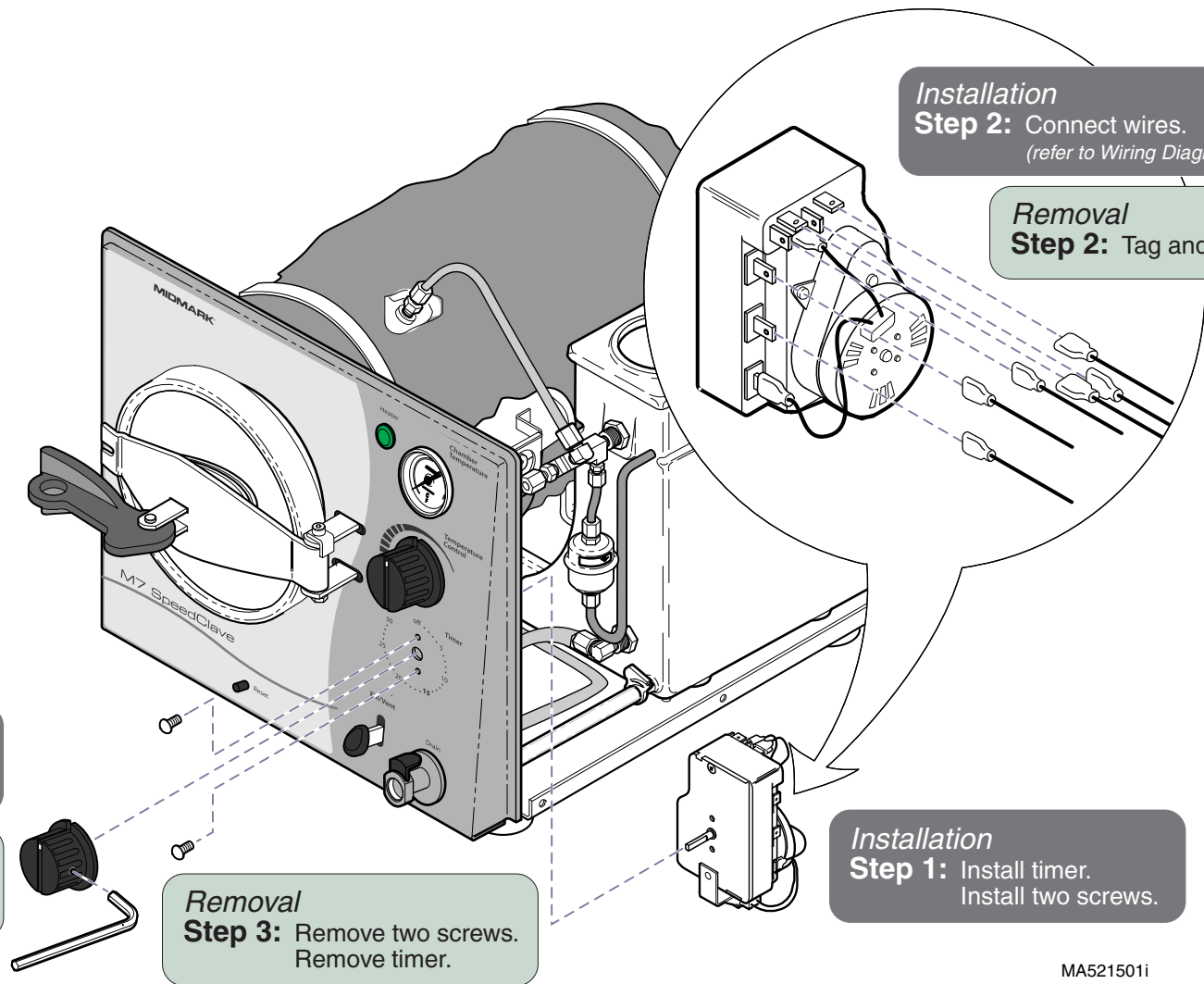

Installation
Step 3: Install timer knob.
Tighten set screw.

Removal
Step 1: Loosen set screw.
Remove timer knob.

Removal
Step 3: Remove two screws.
Remove timer.

Installation
Step 2: Connect wires.
(refer to Wiring Diagrams)

Removal
Step 2: Tag and disconnect wires.

Installation
Step 1: Install timer.
Install two screws.

MA521501i

Models: M7 (-020 thru -022)			
Serial Numbers: all			

Timer

Component Testing & Repair

Timer Buzzer

Location & Function

When the timer setting expires...
Timer contacts to the buzzer close for one minute.
Current flows to the buzzer, causing an audible signal.

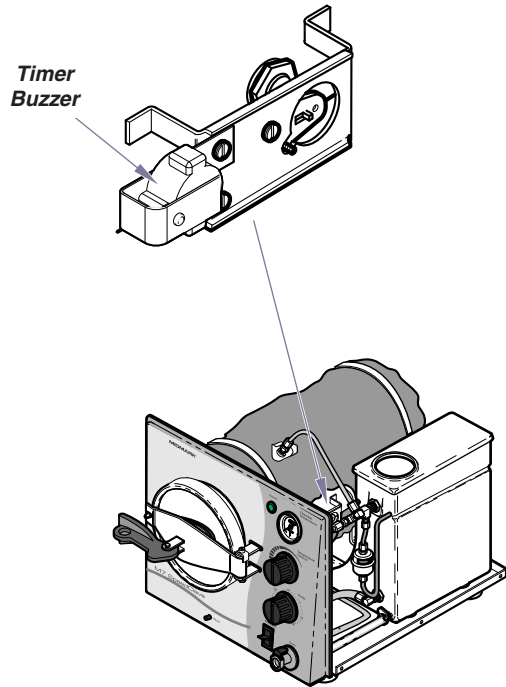

Timer Buzzer	Page
Testing - refer to:	
Timer	B-26
Exploded View / Part Numbers	E-11

Replacement & Volume Adjustment

Volume Adjustment
To increase volume...
Loosen adjustment screw.
To decrease volume...
Tighten adjustment screw.

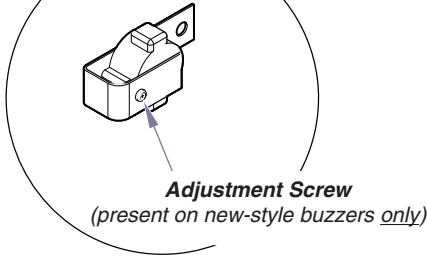

Installation
Step 1: Install buzzer.

Removal
Step 2: Remove buzzer.

Removal
Step 1: Disconnect buzzer wires.

Installation
Step 2: Connect buzzer wires.

MA676100i

Temperature Gauge

Replacement

Temperature Gauge

Page

Exploded View / Part Numbers E-5

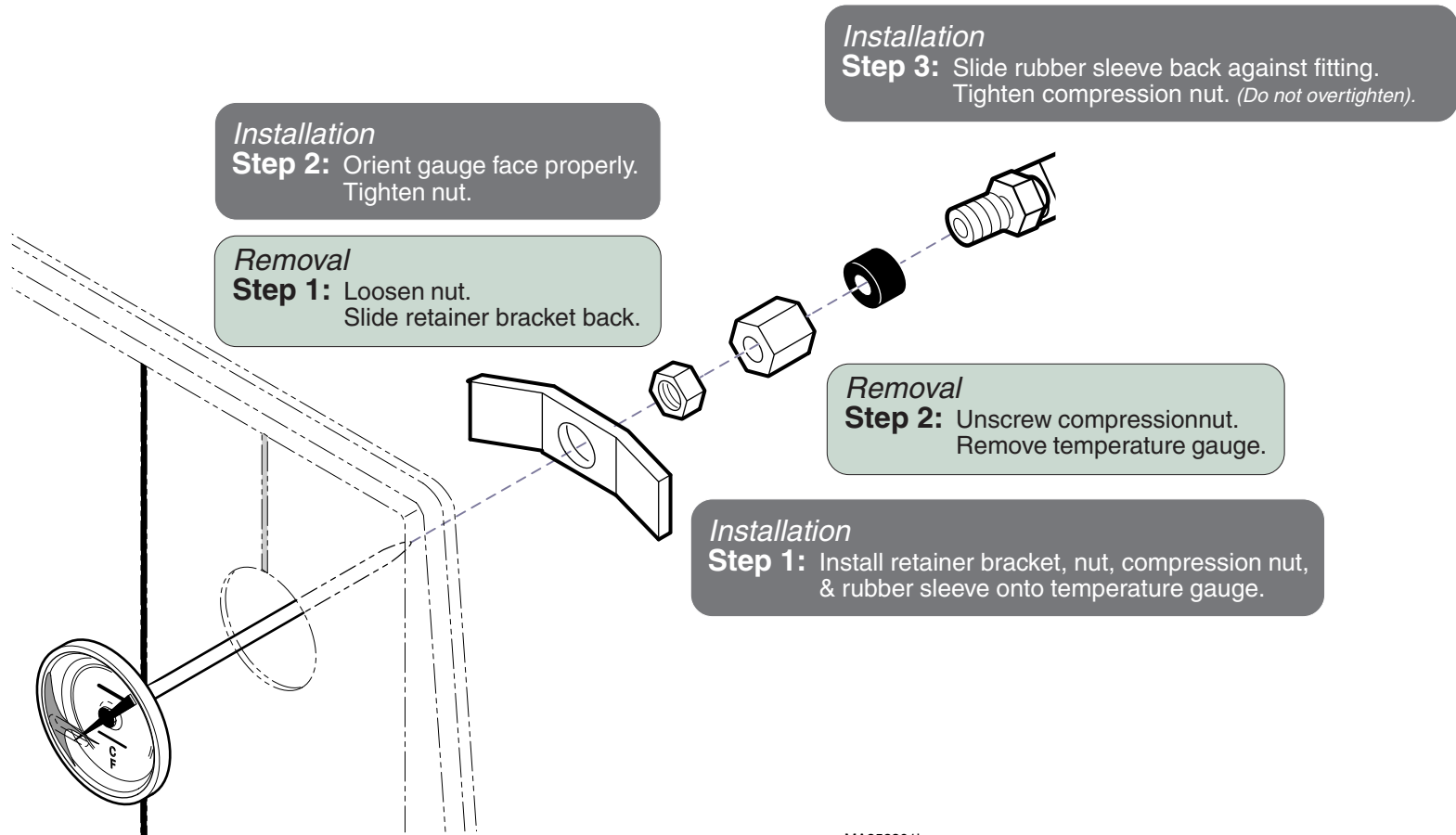

MA252301i

Models: | M7 (-020 thru -022) |
Serial Numbers: | all |

Temperature Gauge

B-29

Component Testing & Repair

Door Assembly

Door Replacement

<u>Door Assembly</u>	<u>Page</u>
Testing - refer to:	
Checking for Pressure Leaks	B-2
Disassembly / Assembly	B-31
Exploded View / Part Numbers	E-5

Door Removal
Step 1: Move door handle to unlatched position.

Door Installation
Step 1: Install door stop & screw.

Door Removal
Step 2: Remove nut, screw, & door stop.

Door Installation
Step 2: Install nut* (*Do not overtighten*)
 *apply removeable threadlocking adhesive

Gasket Replacement

Gasket Installation
Step 1: Using a brush, clean all debris from gasket channel.

Gasket Installation
Step 2: Lubricate gasket w/soapy water. Insert gasket into gasket channel.

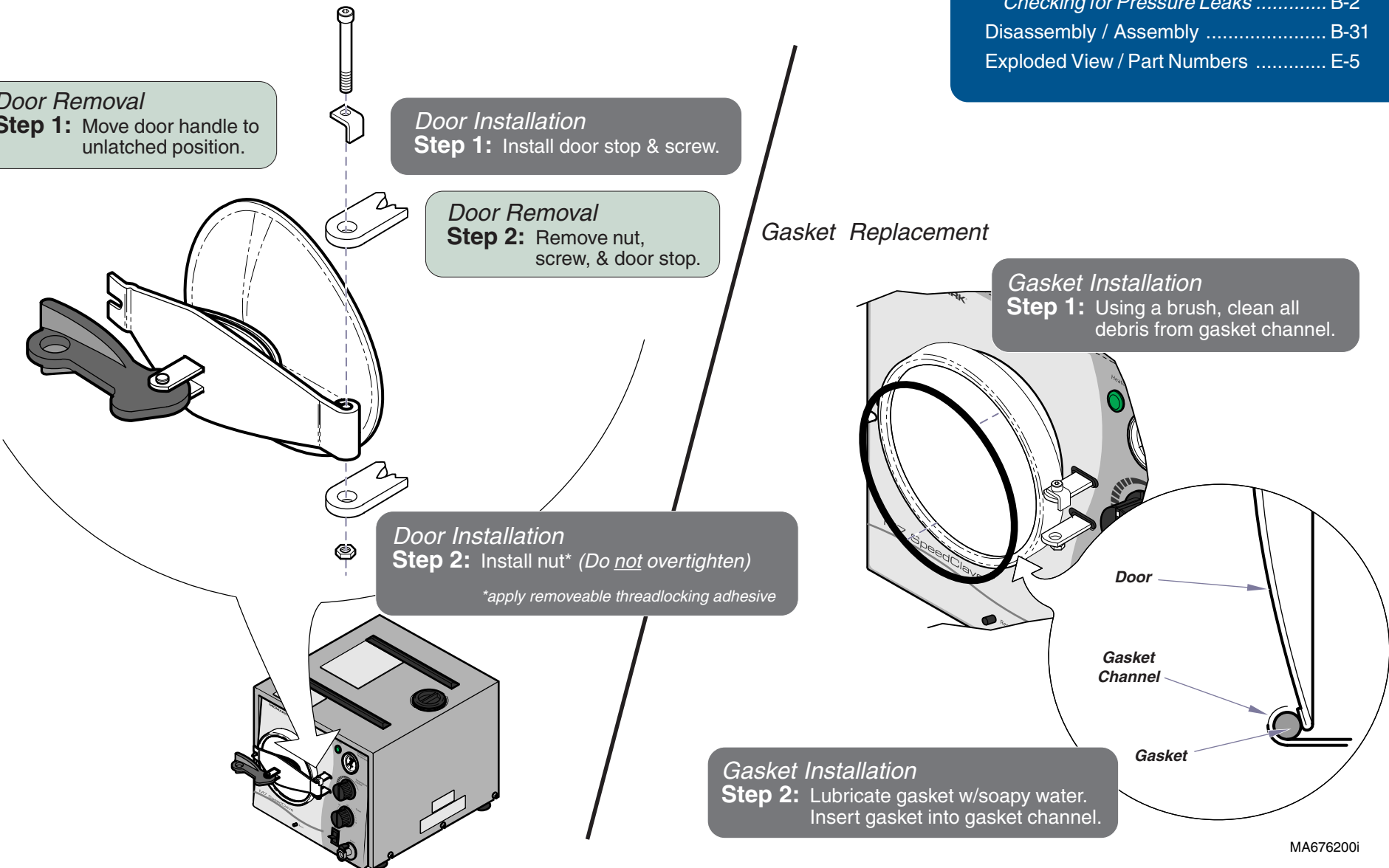

MA676200i

Component Testing & Repair

Door Assembly - continued

Disassembly / Assembly

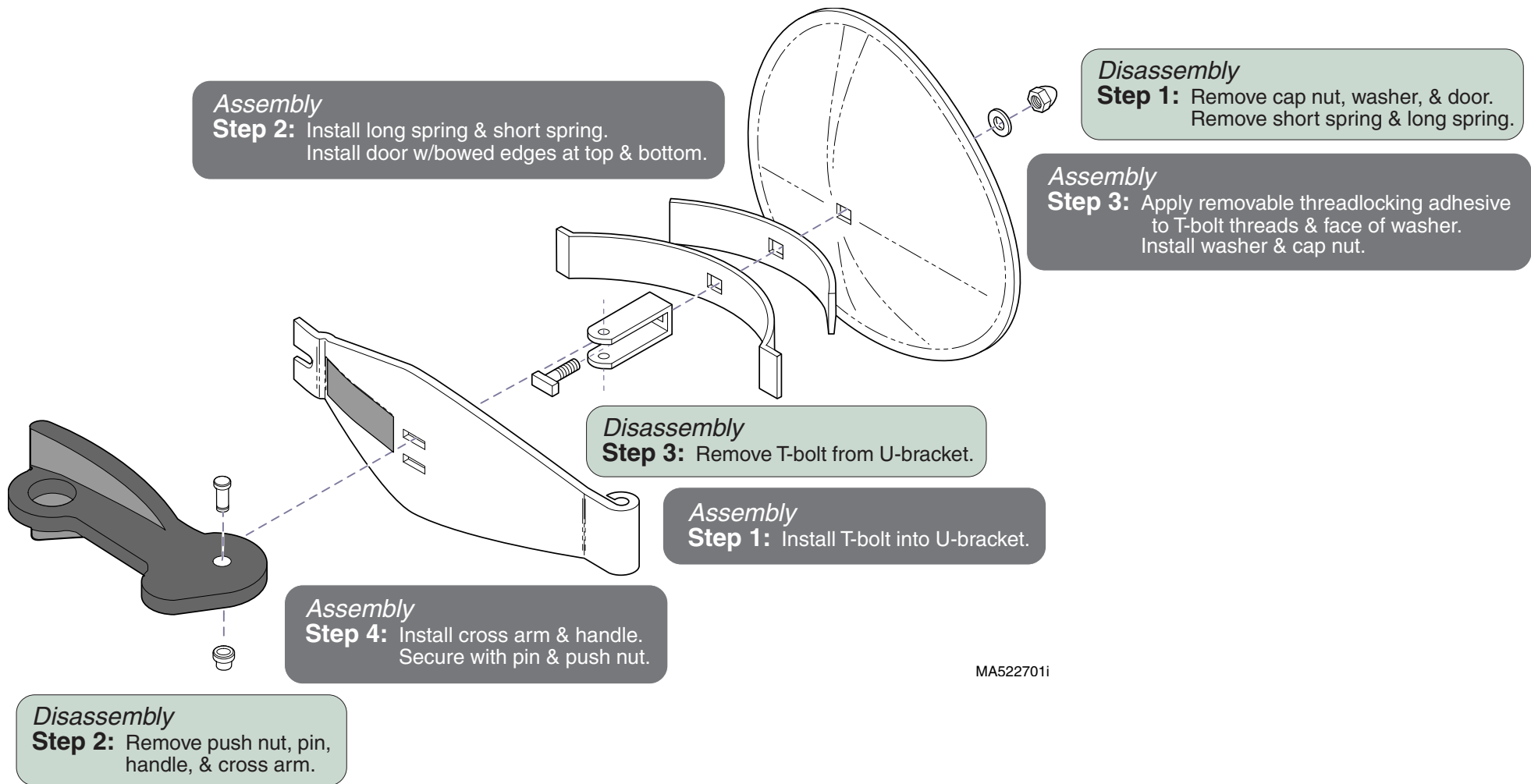

Models: | M7 (-020 thru -022) |
Serial Numbers: | all |

Door Assembly

B-31

Component Testing & Repair

Reservoir Tank

Removal

Reservoir Tank	Page
Installation	B-33
Exploded View / Part Numbers	E-7

Removal
Step 1: Drain all water from reservoir.

Removal
Step 2: Loosen nut.

Removal
Step 7: Pull bellows tube out of tank.

Removal
Step 5: Loosen nut.

Removal
Step 4: Remove clamp & drain hose.

Removal
Step 3: Remove bulkhead fitting & washer.

Removal
Step 6: Remove condensing coil, & washer.

Removal
Step 8: Remove four screws & tank.

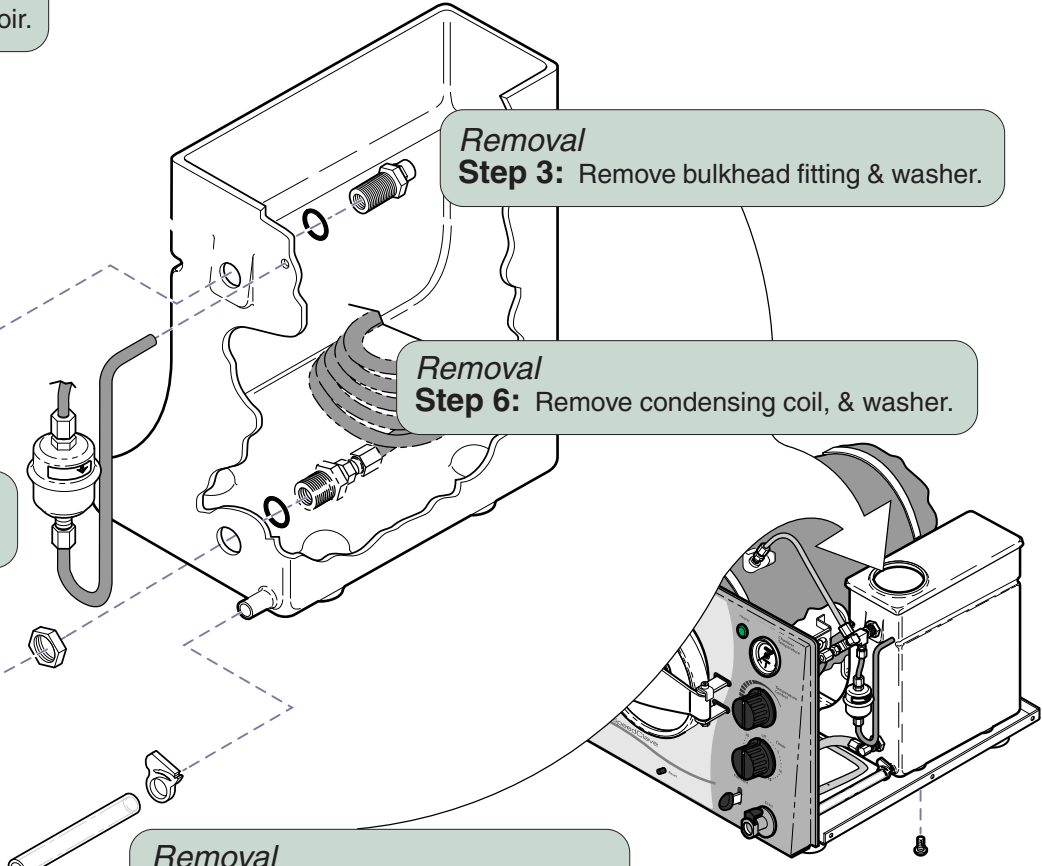

MA5230011

Reservoir Tank

Installation

Note

When reconnecting plumbing, apply teflon tape or sealant to threads - except where compression fittings are used.

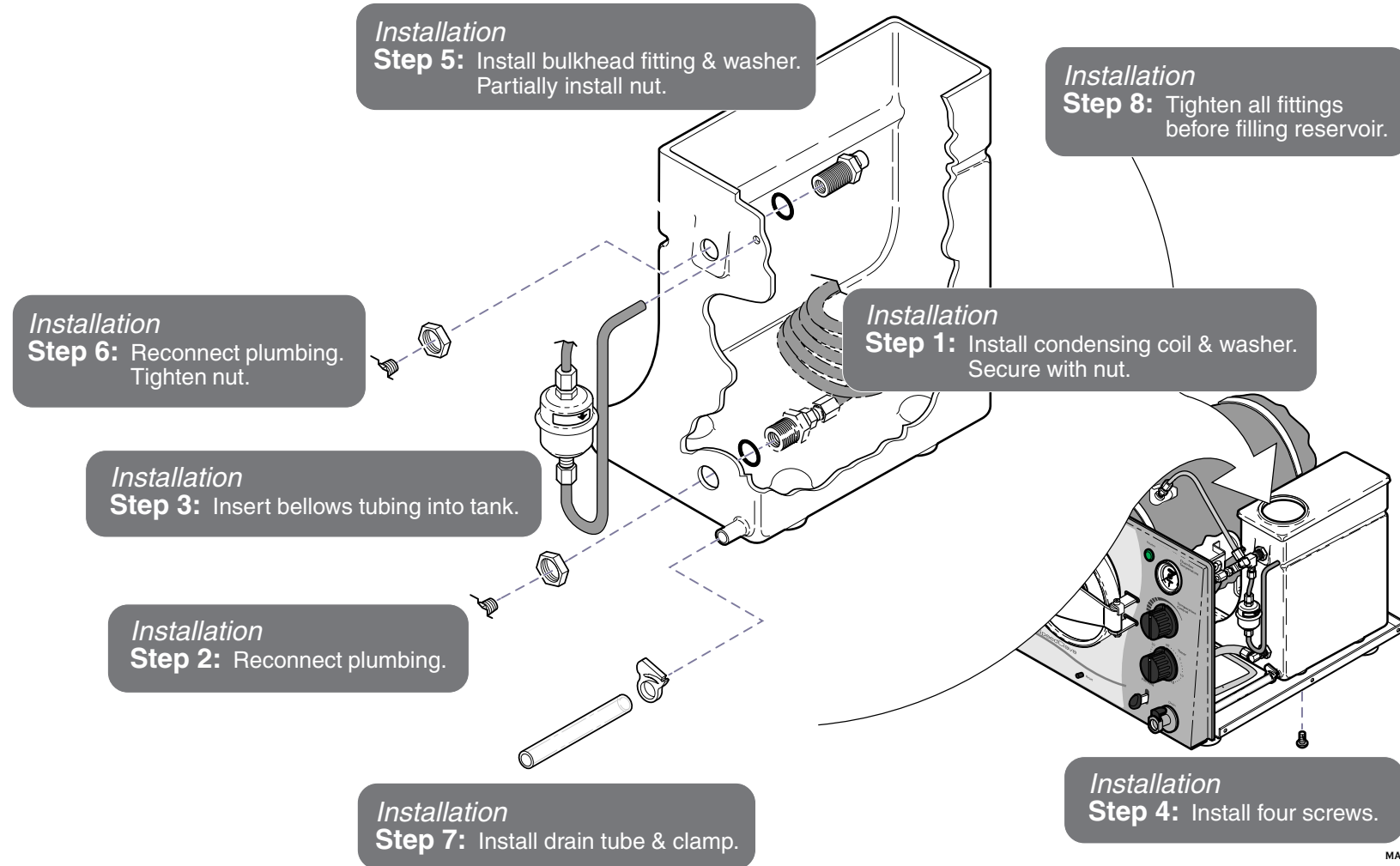

MA5230011

Models: M7 (-020 thru -022)
Serial Numbers: all

Reservoir Tank

Component Testing & Repair

Chamber Assembly

Removal

Removal

Step 1: Drain all water from reservoir.

Removal

Step 2: Remove the following components:

- Covers
- Tray Plate / Rack
- Door Assembly & Gasket
- Temperature Regulator Assy.
- Heating Element
- Overheat Thermostats

Removal

Step 3: Disconnect compression fitting from top of chamber.

Removal

Step 5: Remove screw(s) securing bracket* to base. Remove chamber.

* Bracket design may vary.

Removal

Step 4: Disconnect compression fitting from bottom of chamber.

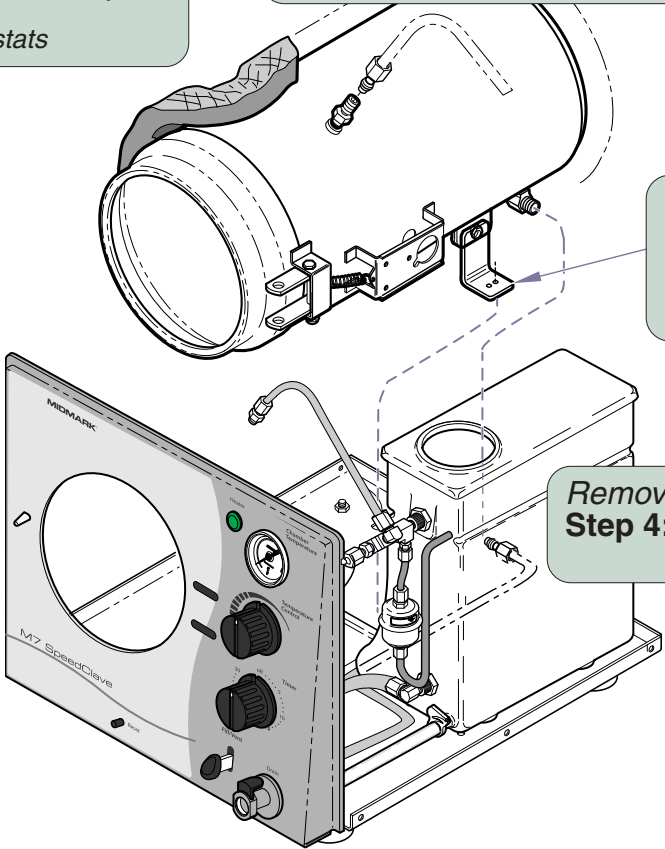

<u>Chamber Assembly</u>	<u>Page</u>
Disassembly / Assembly	B-35
Installation	B-36
Exploded View / Part Numbers	E-9
<u>Refer to (Removing):</u>	
Covers	C-2
Tray Plate / Rack	C-3
Door Assembly / Gasket	B-30
Temperature Regulator Assembly	B-13
Heating Element	B-18
Overheat Thermostats	B-22

Component Testing & Repair

Chamber Assembly - continued

Disassembly / Assembly

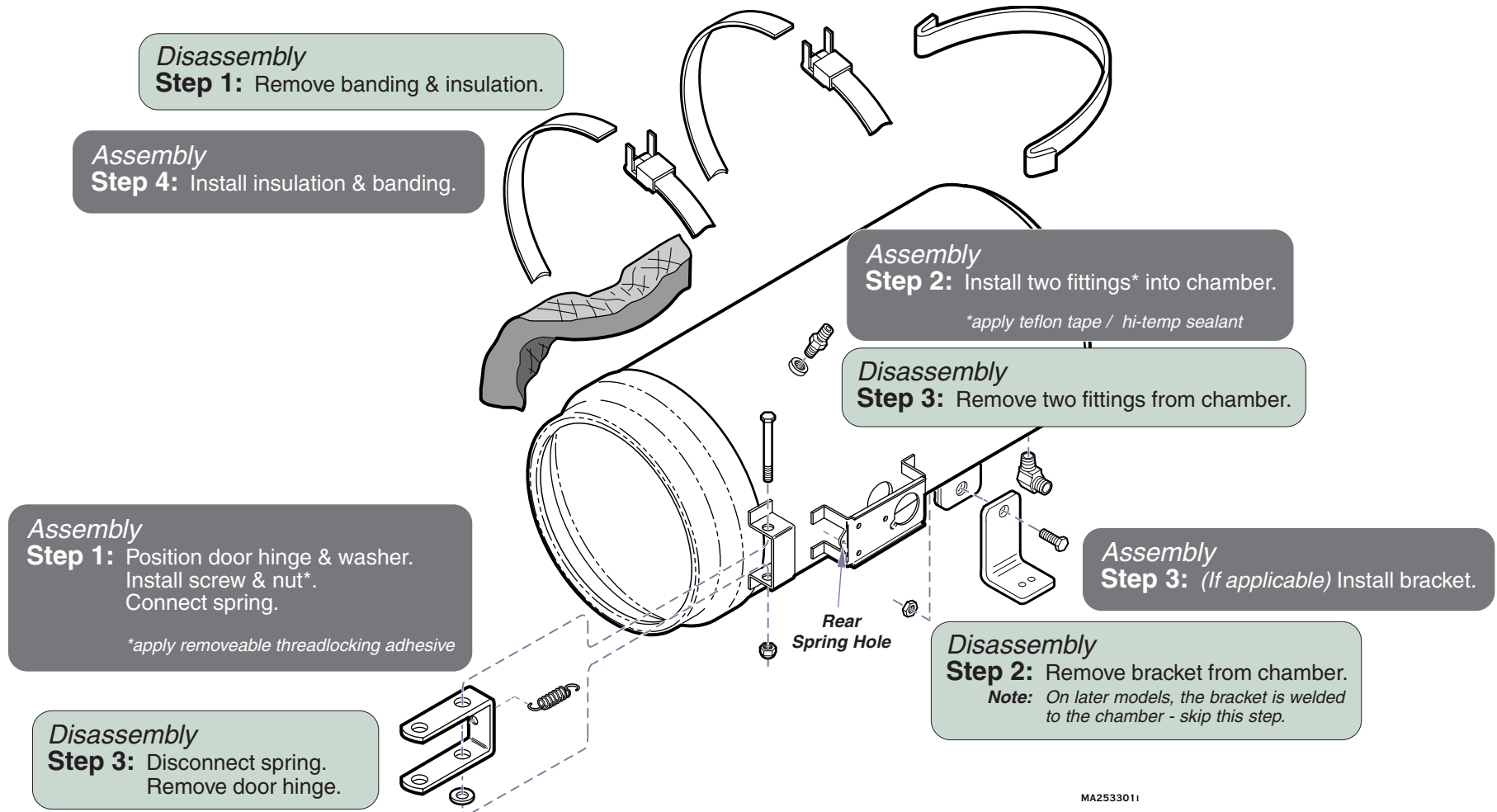

Models: | M7 (-020 thru -022) |
Serial Numbers: | all |

Chamber Assembly

B-35

Component Testing & Repair

Chamber Assembly- continued

Installation

Note
Replace compression fittings if damage is apparent.

Refer to (Installing):

- Overheat Thermostats B-22
- Heating Element B-18
- Temperature Regulator Assembly B-14
- Door Assembly / Gasket B-30
- Tray Plate / Rack C-3
- Covers C-2

Assembly Step 3: Connect compression fitting / plumbing to fitting on top of chamber.

Assembly Step 4: Install the following components:
Overheat Thermostats
Heating Element
Temperature Regulator Assy.
Door Assembly & Gasket
Tray Plate / Rack
Covers

Installation Step 1: Secure bracket* to base.
**Bracket design may vary.*

Assembly Step 2: Connect compression fitting / plumbing to fitting on bottom of chamber.

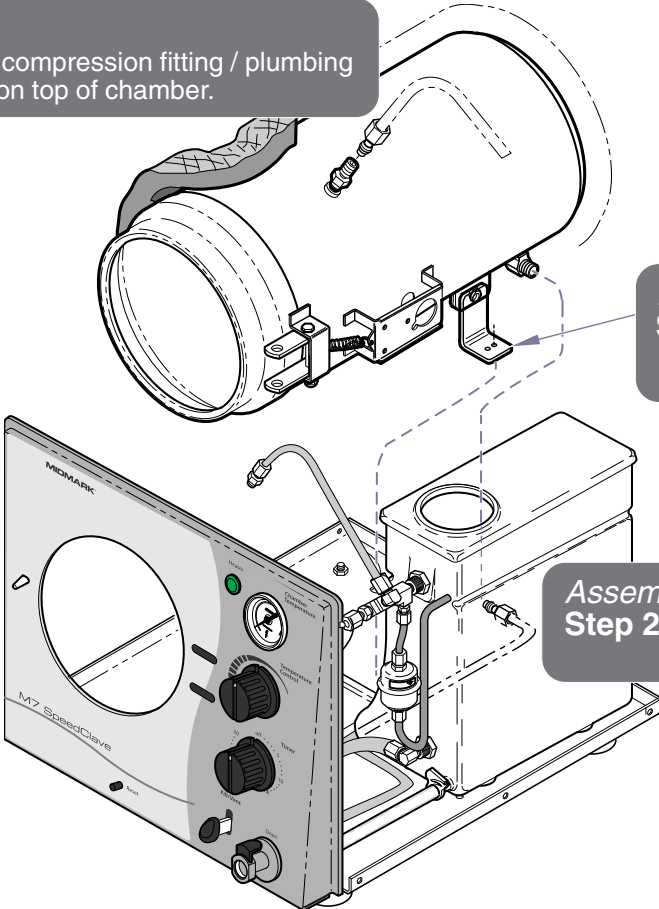

MA5231011

Section C

Access Procedures

<u>Removing & Installing:</u>	<u>Page</u>
Covers / Panels	C-2
Tray Plate / Rack	C-3
Draining / Filling the Reservoir	C-4

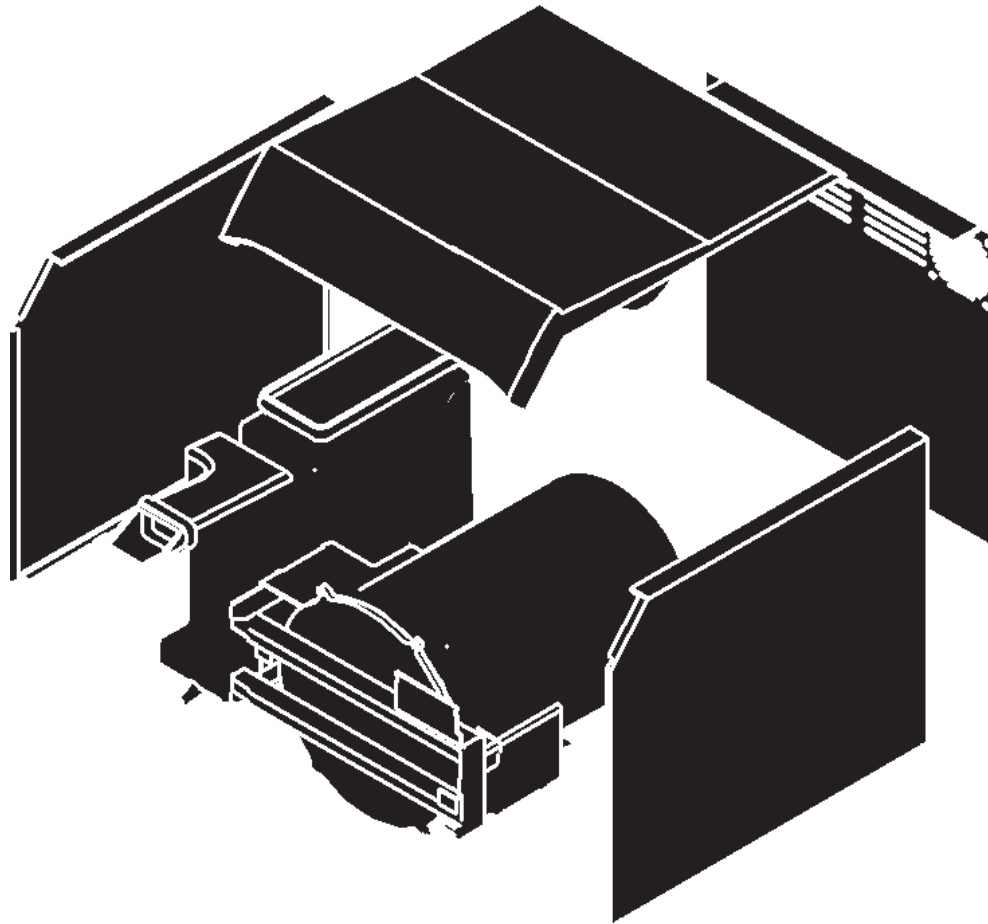

Access Procedures

Covers / Panels

Removal / Installation



Caution

Always unplug power cord before removing any covers / panels.

Refer To:

Page

Operation & Troubleshooting	A-1
Component Testing / Repair	B-1
Access Procedures	C-1
Wiring Diagrams	D-1
Exploded Views / Part Numbers	E-1

Removal

Step 2: Remove cover.

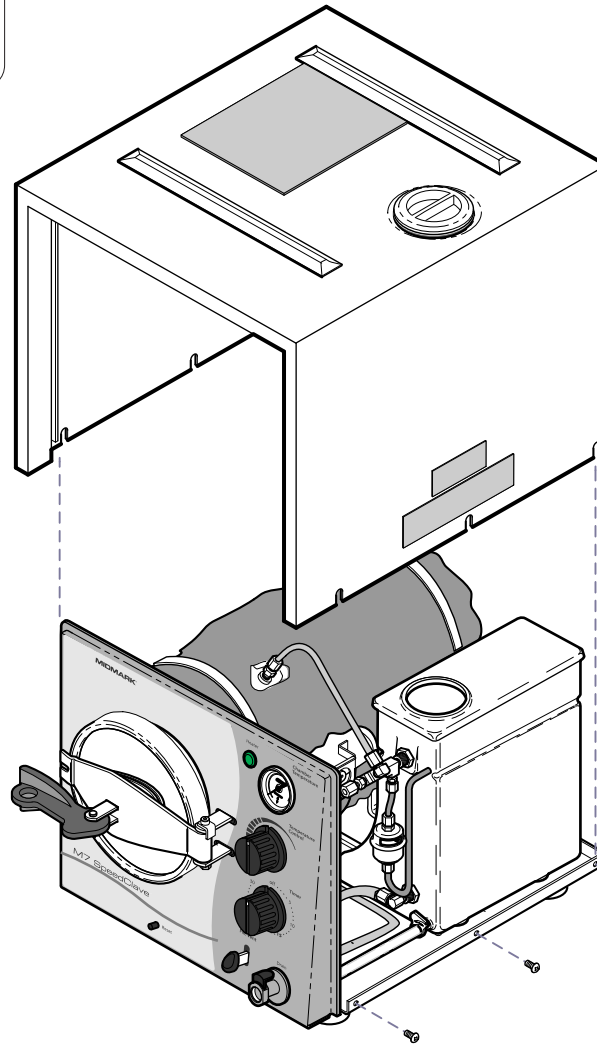

Installation: M7 (-011 thru -016)

Step 1: Slide cover down over edge of front panel.

Installation: M7 (-020 thru -022)

Step 1: Slide cover down over edge of front panel & back panel (not shown).

Removal

Step 1: Remove six screws.

Installation: M7 (all)

Step 2: Install six screws.

MA5214011

Tray Plate / Rack

Removal / Installation

Caution
Always allow unit to cool before removing trays or rack.

Refer To:	Page
Operation & Troubleshooting	A-1
Component Testing / Repair	B-1
Access Procedures	C-1
Wiring Diagrams	D-1
Exploded Views / Part Numbers	E-1

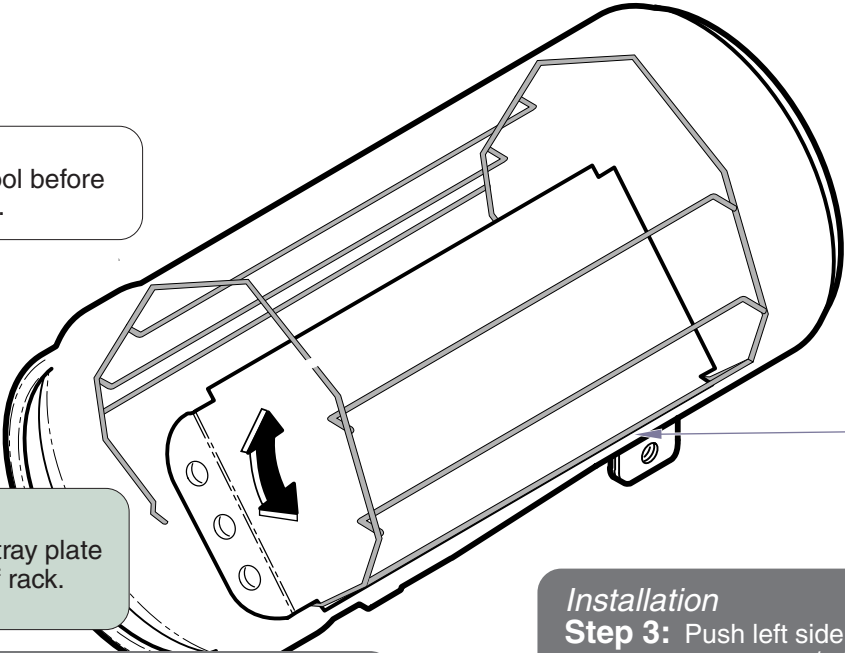

Removal Step 1: Lift up on left side of tray plate until it "pops" free of rack. Remove tray plate.

Installation Step 2: Insert the right side of tray plate under bottom wire of rack.

Installation Step 3: Push left side of plate down until it engages w/ offset ends of rack.

Removal Step 2: Squeeze bottom of rack together. Pull rack out of chamber.

Installation Step 1: Position rack w/ offset ends to the left. Squeeze bottom of rack together. Push rack into chamber.

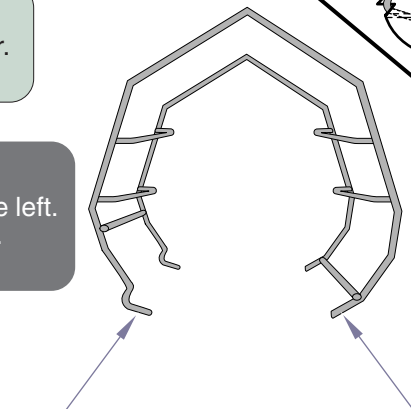
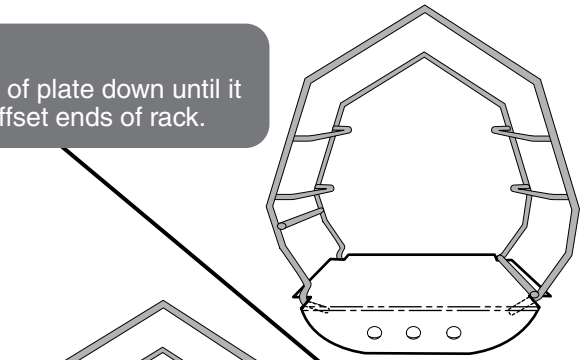

Models: M7 (-020 thru -022)			
Serial Numbers: all			

Tray Plate / Rack

MA539101

Access Procedures

Draining / Filling the Reservoir

Note: To remove drain hose, press release lever.

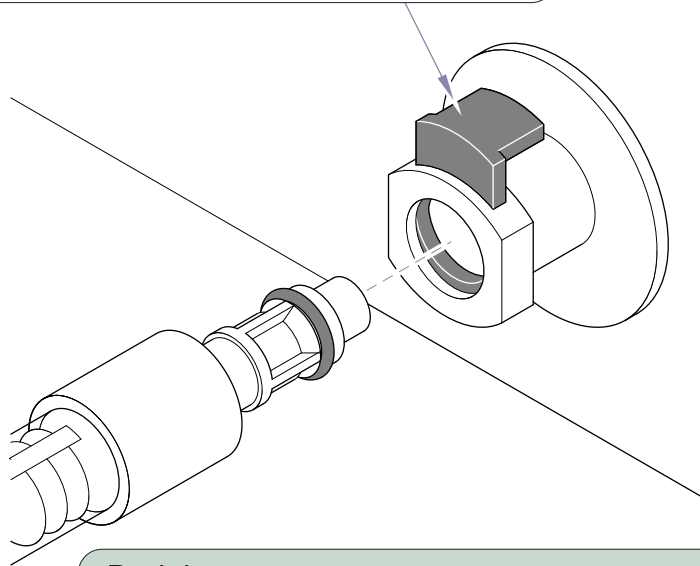

Draining

Step 1: Hold hose over a drain or suitable container. Insert drain hose into coupling on front of unit.

Note: The max. reservoir capacity is: 1.3 gallon (4.9 liters)

Refer To:	Page
Operation & Troubleshooting	A-1
Component Testing / Repair	B-1
Access Procedures	C-1
Wiring Diagrams	D-1
Exploded Views / Part Numbers	E-1

Filling

Step 1: Pour distilled water into reservoir until the water level reaches the "full mark". Do **not** overfill!

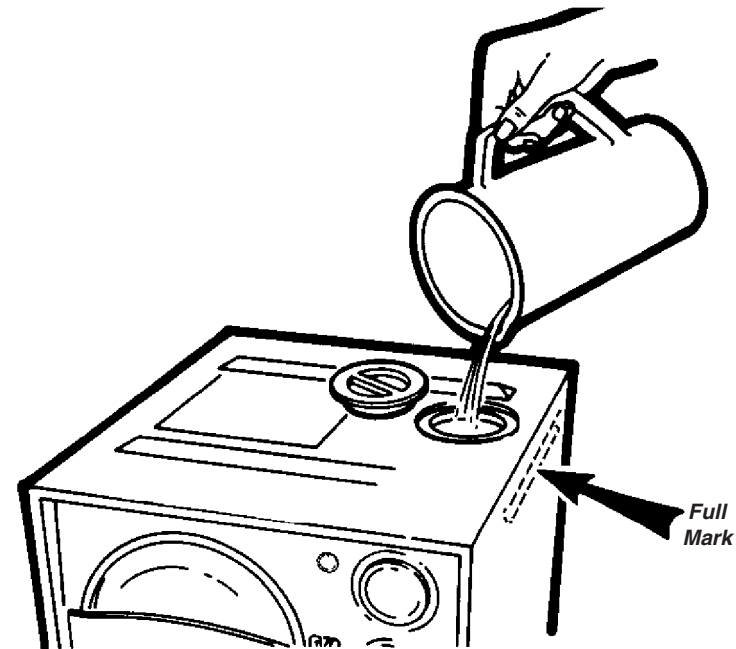

MA514002

Section D

Wiring Diagrams & Schematics

Model

Page

115 VAC models:

M7 (-020 / -022) D-2

230 VAC models:

M7 (-021) D-3

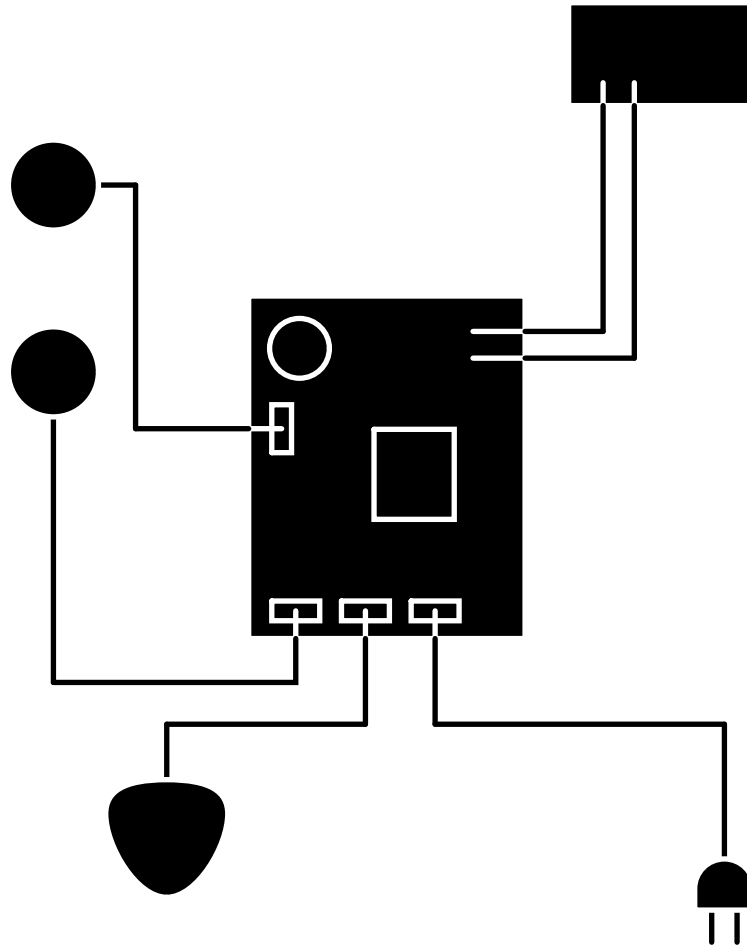

Wiring Diagrams - 115VAC Models

Refer To:	Page
Operation & Troubleshooting	A-1
Component Testing / Repair	B-1
Access Procedures	C-1
Wiring Diagrams	D-1
Exploded Views / Part Numbers	E-1

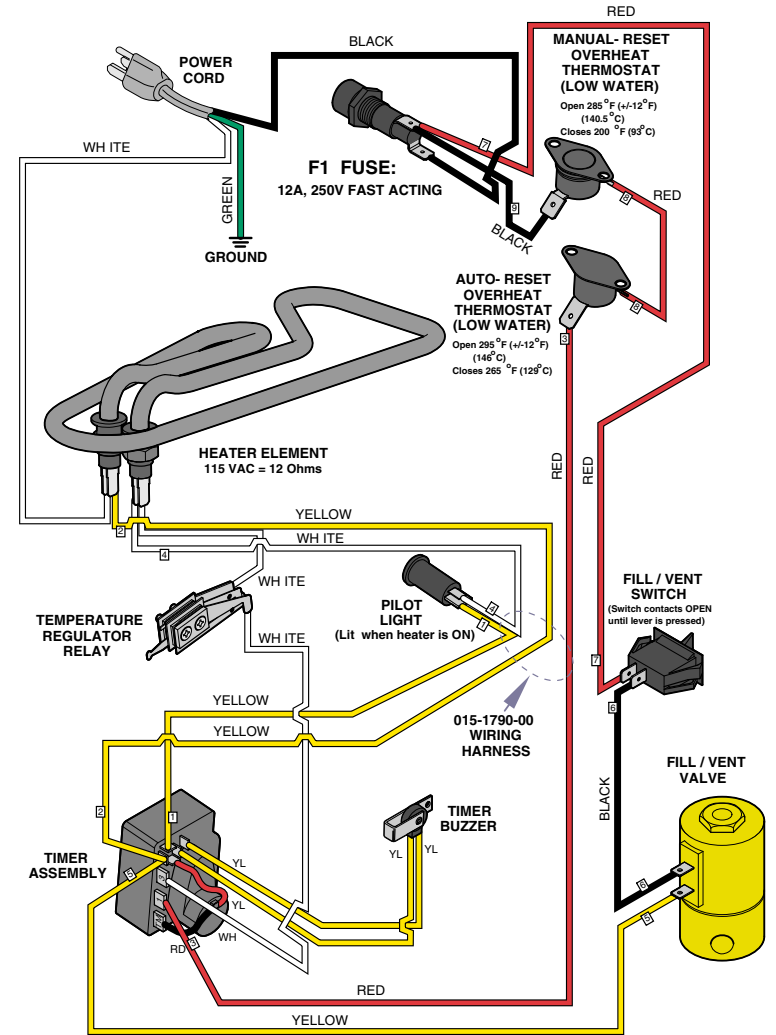
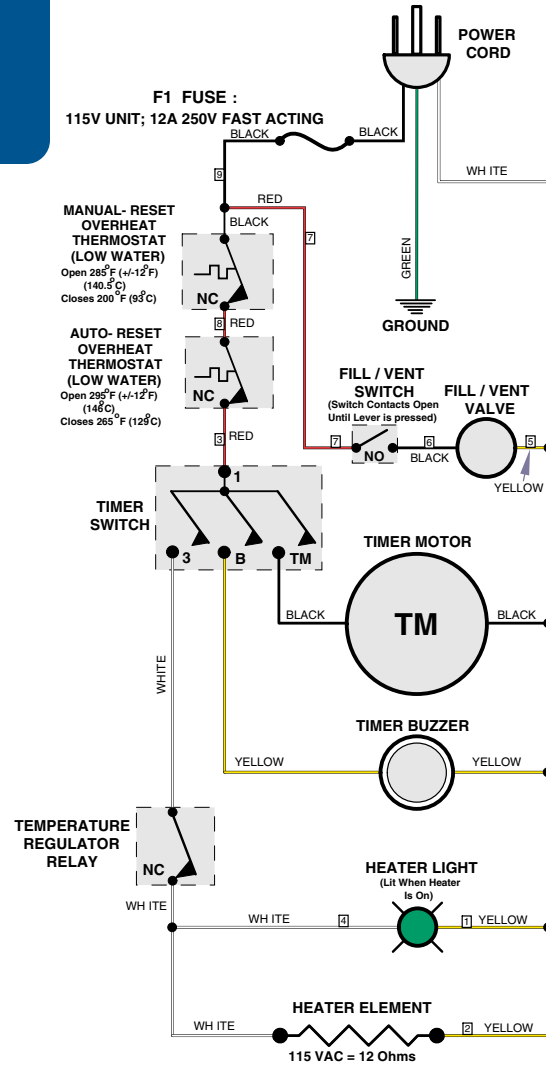

Wiring Diagrams - 230VAC Models

Refer To:	Page
Operation & Troubleshooting	A-1
Component Testing / Repair	B-1
Access Procedures	C-1
Wiring Diagrams	D-1
Exploded Views / Part Numbers	E-1

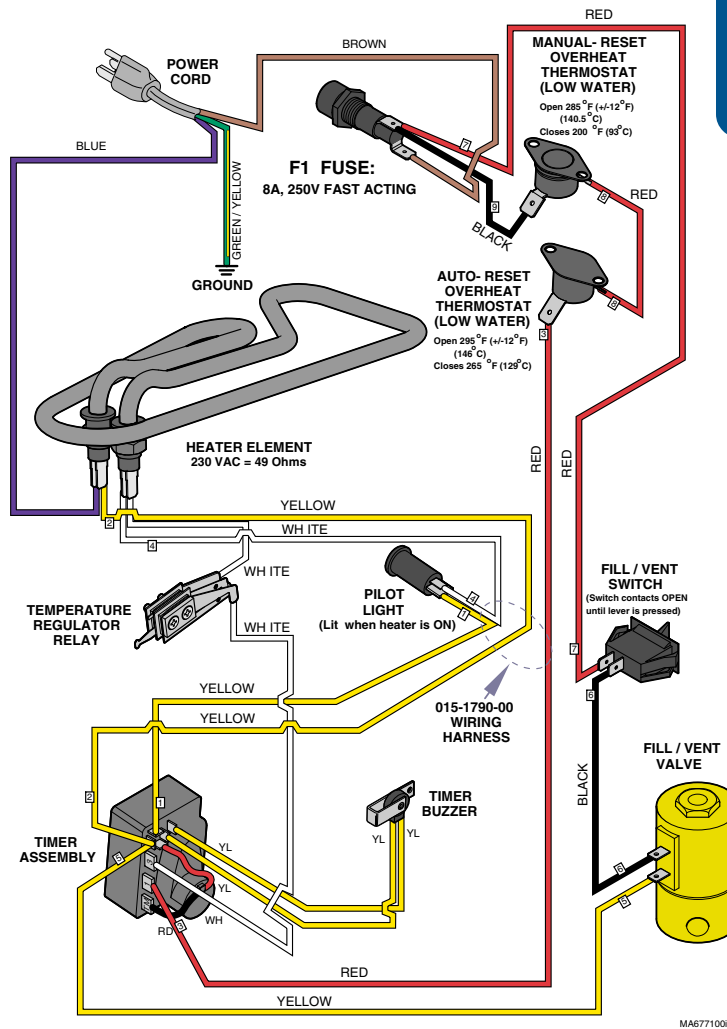
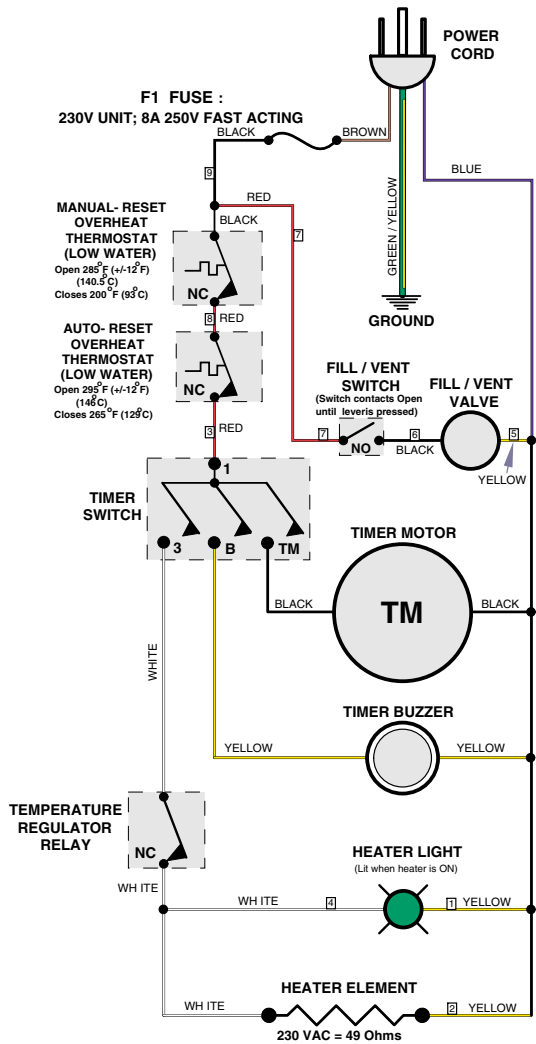

Models:
Serial Numbers:

M7 (-021)
all

Wiring Diagrams
(230 VAC Model)

Section E

Exploded Views & Parts Lists

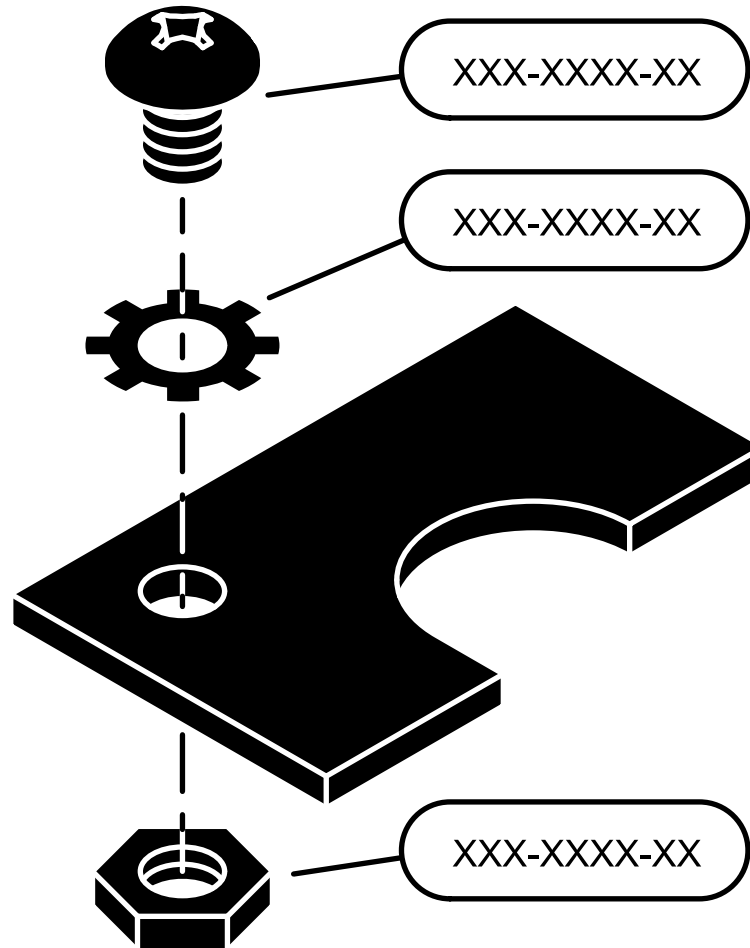

M7 (-020 thru -022)

Items not shown:
**Heating Element
& Thermostats** E-12
Power Cord E-13
Rack & Trays E-14
Packaging E-15

Covers E-3

includes:
main cover, base plate,
leveling feet, fill cap, etc.

**Chamber
Components** E-9

includes:
fittings & mounting bracket

Door Components E-5

includes:
hinge, & door gasket

**Front Panel
Components** E-4

includes:
heater light, thermometer,
knobs, & drain coupling

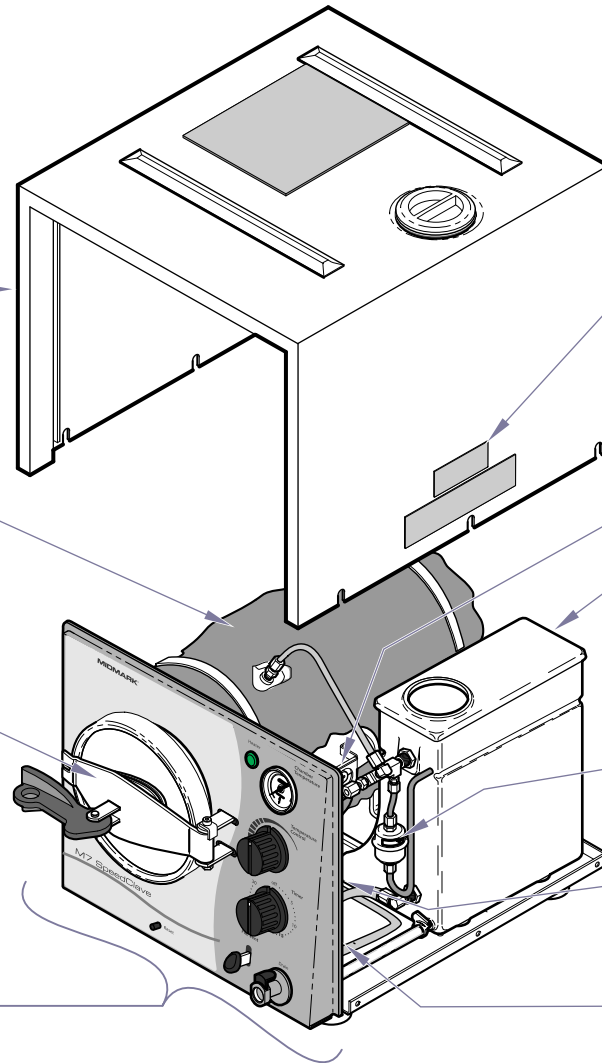

Labels & Decals E-16

**Temperature Regulator
Components** E-6

includes:
temp. relay & diaphragm cup

Reservoir E-7

includes:
condensing coil & drain tube

Bellows & Plumbing ... E-10

Timer & Buzzer E-11

**Fill / Vent Valve
& Plumbing** E-8

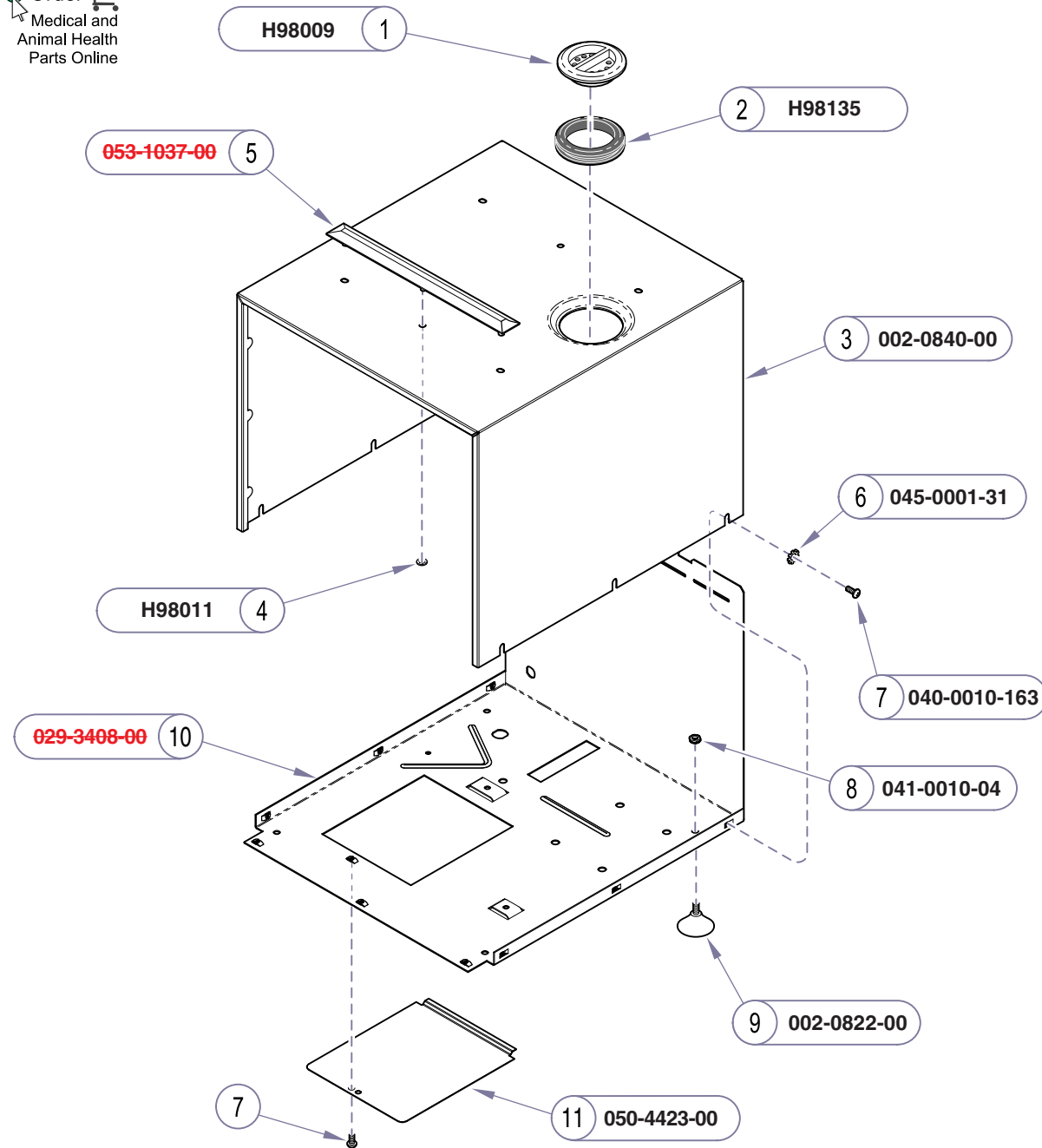

Refer To:	Page
Operation & Troubleshooting	A-1
Component Testing / Repair	B-1
Access Procedures	C-1
Wiring Diagrams	D-1
Exploded Views / Part Numbers ..	E-1

Item	Description	Qty.
1	Fill Cap	1
2	Rubber Seal	1
3	Main Cover w/ labels (includes items 4 & 5)	1
4	Push Nut	6
5	Cooling Rail	2
6	Lockwasher	1
7	Screw (#10 x 5/8", self-drilling/tapping)	7
8	Nut (used only on units built prior to serial number V411489)	4
9	Rubber Foot Kit (includes nut)	4
10	Base Assembly	1
11	Inspection Cover	1

Always Specify Model & Serial Number

MA674101i

Models: | M7 (-020 thru -022) |
Serial Numbers: | all |

Covers

Refer To:	Page
Operation & Troubleshooting	A-1
Component Testing / Repair	B-1
Access Procedures	C-1
Wiring Diagrams	D-1
Exploded Views / Part Numbers ..	E-1

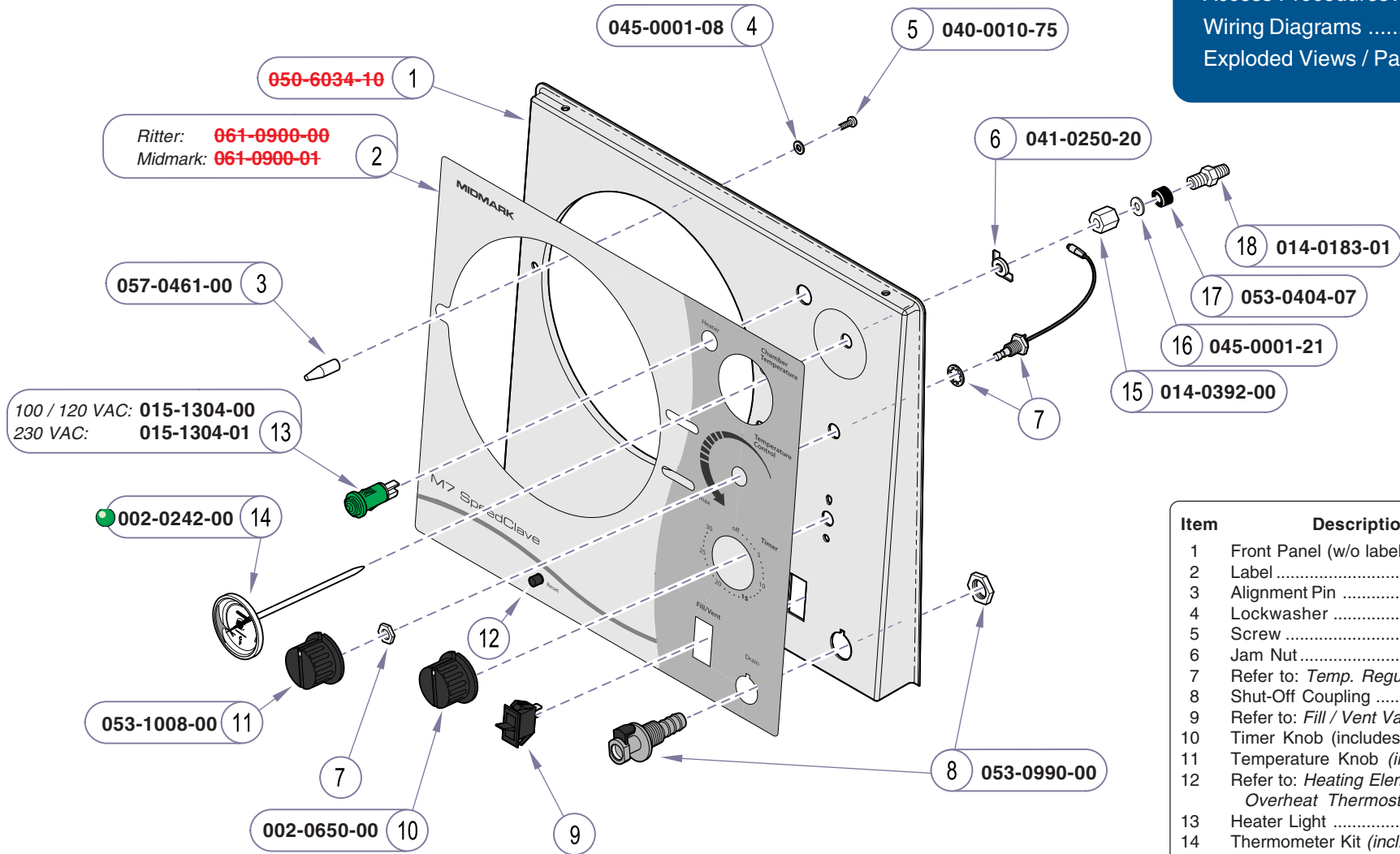

Item	Description	Qty.
1	Front Panel (w/o label)	1
2	Label	1
3	Alignment Pin	1
4	Lockwasher	1
5	Screw	1
6	Jam Nut	1
7	Refer to: <i>Temp. Regulator Components</i> E-7	
8	Shut-Off Coupling	1
9	Refer to: <i>Fill / Vent Valve</i>	E-9
10	Timer Knob (includes setscrew)	1
11	Temperature Knob (includes setscrew)	1
12	Refer to: <i>Heating Element / Overheat Thermostats</i>	E-13
13	Heater Light	1
14	Thermometer Kit (incl. items 15 thru 18) ...	1
15	• Compression Nut	1
16	• Washer	1
17	• Rubber Sleeve	1
18	• Male Connector	1

Always Specify Model & Serial Number

MA671908i

Front Panel Components

Models: | M7 (-020 thru -022)
Serial Numbers: | all

Refer To:	Page
Operation & Troubleshooting	A-1
Component Testing / Repair	B-1
Access Procedures	C-1
Wiring Diagrams	D-1
Exploded Views / Part Numbers ..	E-1

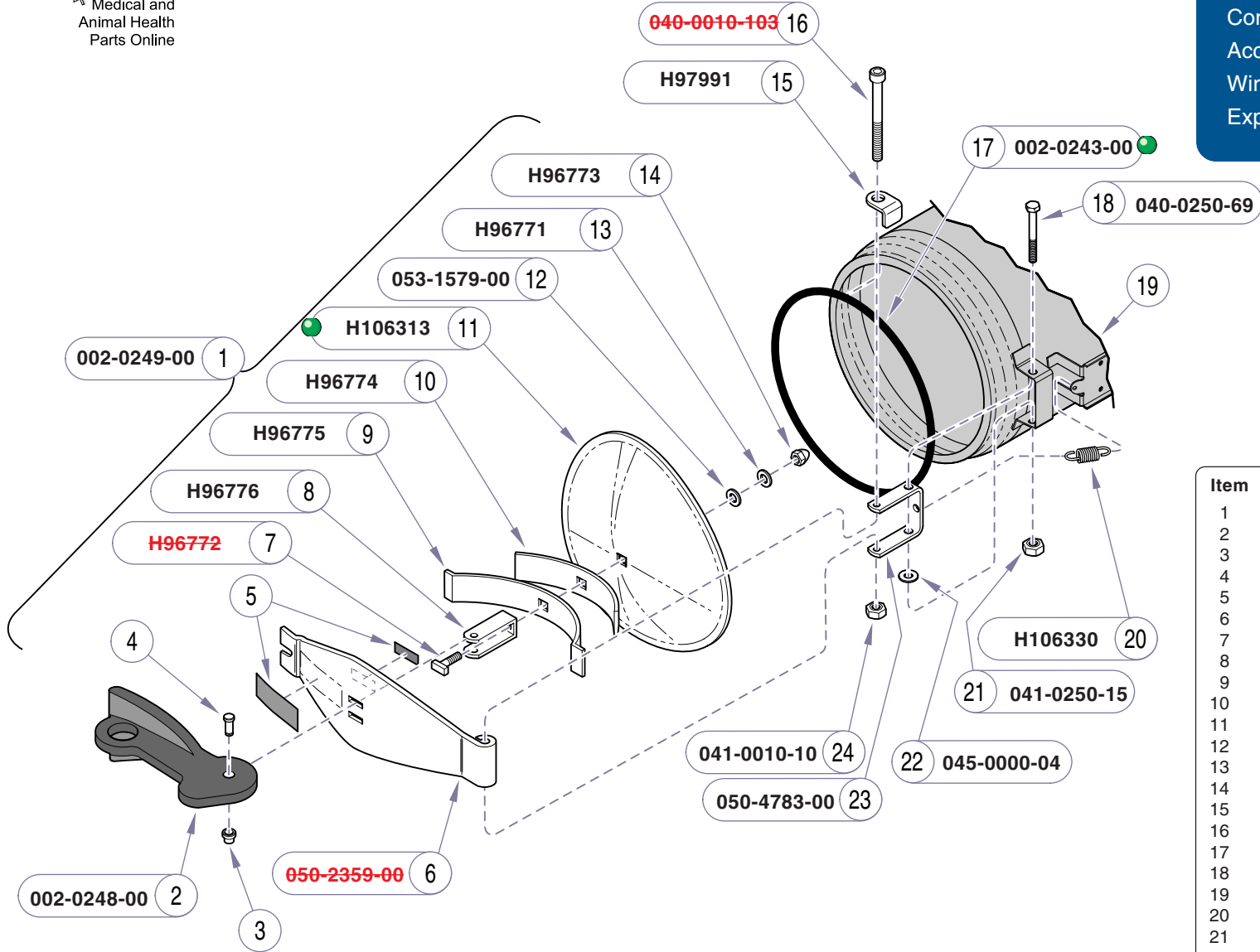

Item	Description	Qty.
1	Door Assembly (incl. items 2 thru 13)	1
2	• Handle (includes items 3 & 4)	1
3	• Push Nut	1
4	• Pin	1
5	• Refer to Label Location	Ref
6	• Cross Arm	1
7	• T-bolt	1
8	• U-bracket	1
9	• Long Spring	1
10	• Short Spring	1
11	• Door	1
12	• Gasket	1
13	• Washer	1
14	• Cap Nut (apply adhesive #042-0024-02) 1	
15	Door Stop	1
16	Bolt	1
17	Door Gasket	1
18	Bolt	1
19	Refer to Chamber Components	Ref
20	Spring	1
21	Torque Nut	1
22	Washer	1
23	Hinge	1
24	Torque Nut	1

Always Specify Model & Serial Number

MA511703i

Models: | M7 (-020 thru -022) |
 Serial Numbers: | all |

Door Components

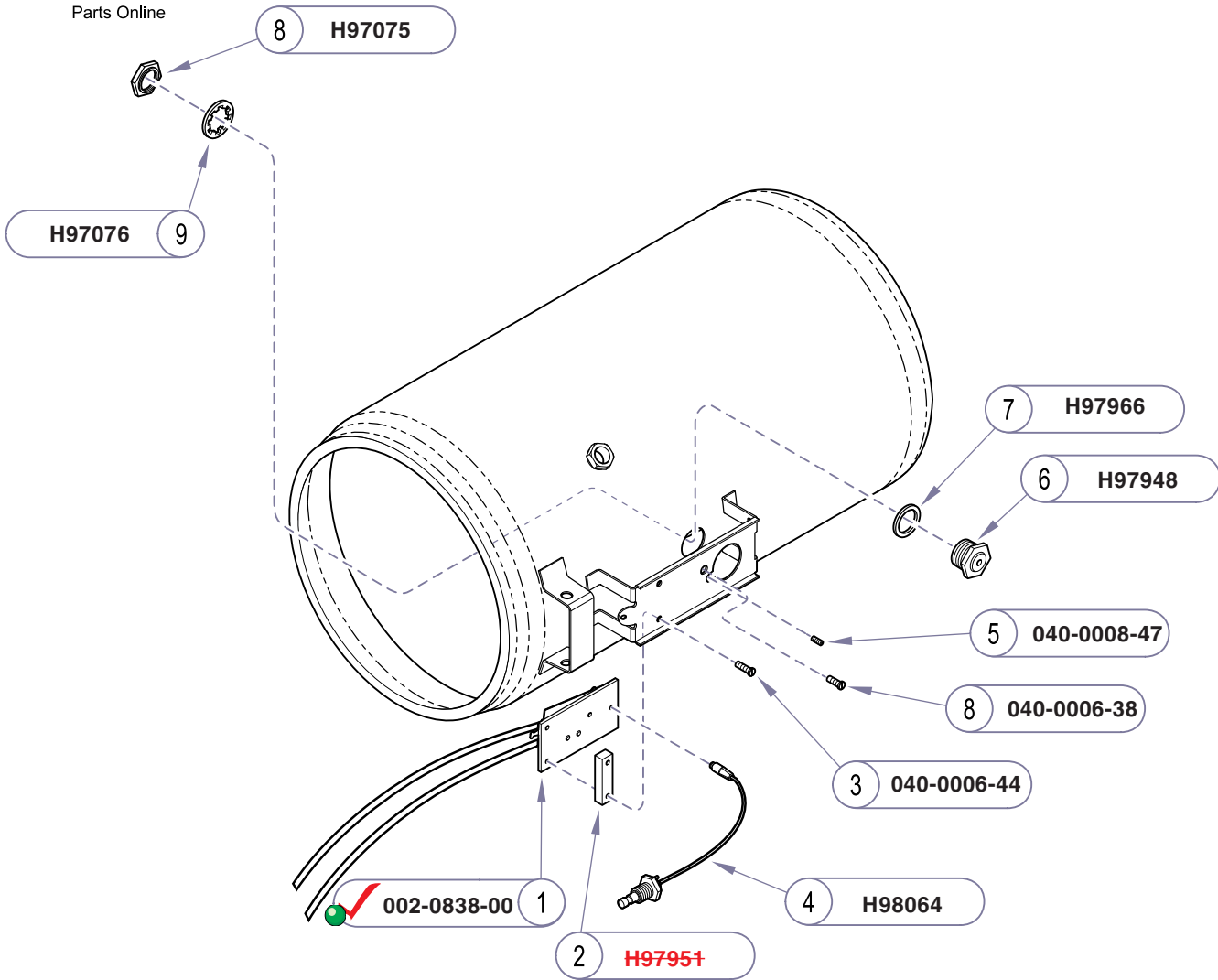

Refer To:	Page
Operation & Troubleshooting	A-1
Component Testing / Repair	B-1
Access Procedures	C-1
Wiring Diagrams	D-1
Exploded Views / Part Numbers ..	E-1

Item	Description	Qty.
1	Temperature Relay Kit (incl. items 2 & 3)	1
2	• Spacer	1
3	• Screw (#6-32 x 7/16")	3
4	Flexible Shaft Assembly	1
5	Set Screw	1
6	Diaphragm Cup	1
7	Gasket	1
8	Nut	1
9	Lockwasher	1

Always Specify Model & Serial Number

MA511902i

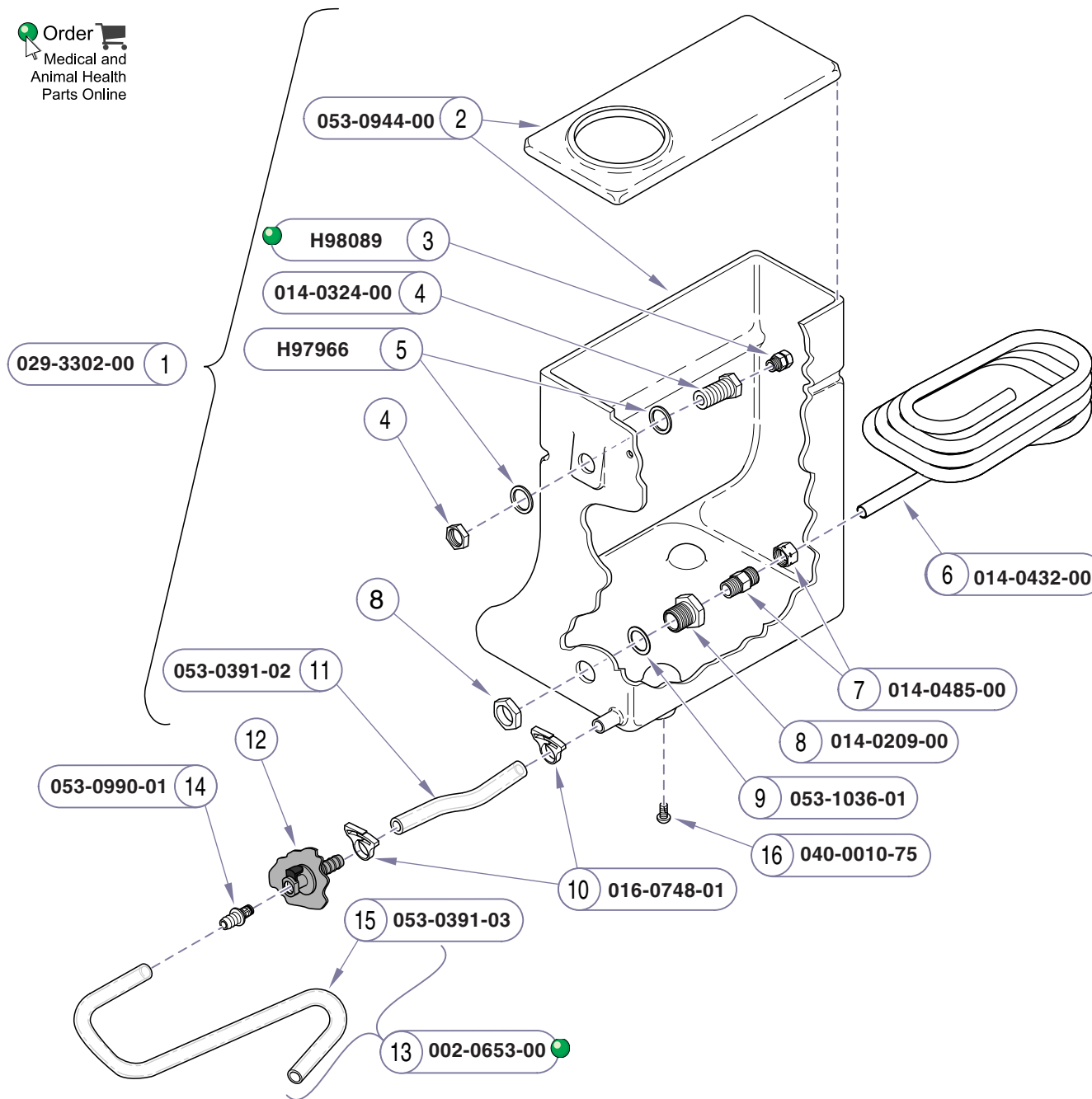

Refer To:	Page
Operation & Troubleshooting	A-1
Component Testing / Repair	B-1
Access Procedures	C-1
Wiring Diagrams	D-1
Exploded Views / Part Numbers ..	E-1

Item	Description	Qty.
1	Reservoir Assembly (incl. i2 thru 11)	1
2	• Tank with Lid (not available separately) ..	1
3	• Pressure Relief Valve	1
4	• Bulkhead Fitting (includes nut)	1
5	• Washer	2
6	• Condensing Coil	1
7	• Compression Fitting	1
8	• Bulkhead Fitting (includes nut)	1
9	• Neoprene Washer	1
10	• Hose Clamp	2
11	• Tank Drain Tube	1
12	Refer to: Front Panel Components	Ref
13	Drain Hose Kit (incl. items 13 thru 15)	1
14	• Barbed Fitting	1
15	• Removeable Drain Tube	1
16	Screw	2

Always Specify Model & Serial Number

MA675106i

Models: | M7 (-020 thru -022) |
 Serial Numbers: | all |

Reservoir

Refer To:	Page
Operation & Troubleshooting	A-1
Component Testing / Repair	B-1
Access Procedures	C-1
Wiring Diagrams	D-1
Exploded Views / Part Numbers ..	E-1

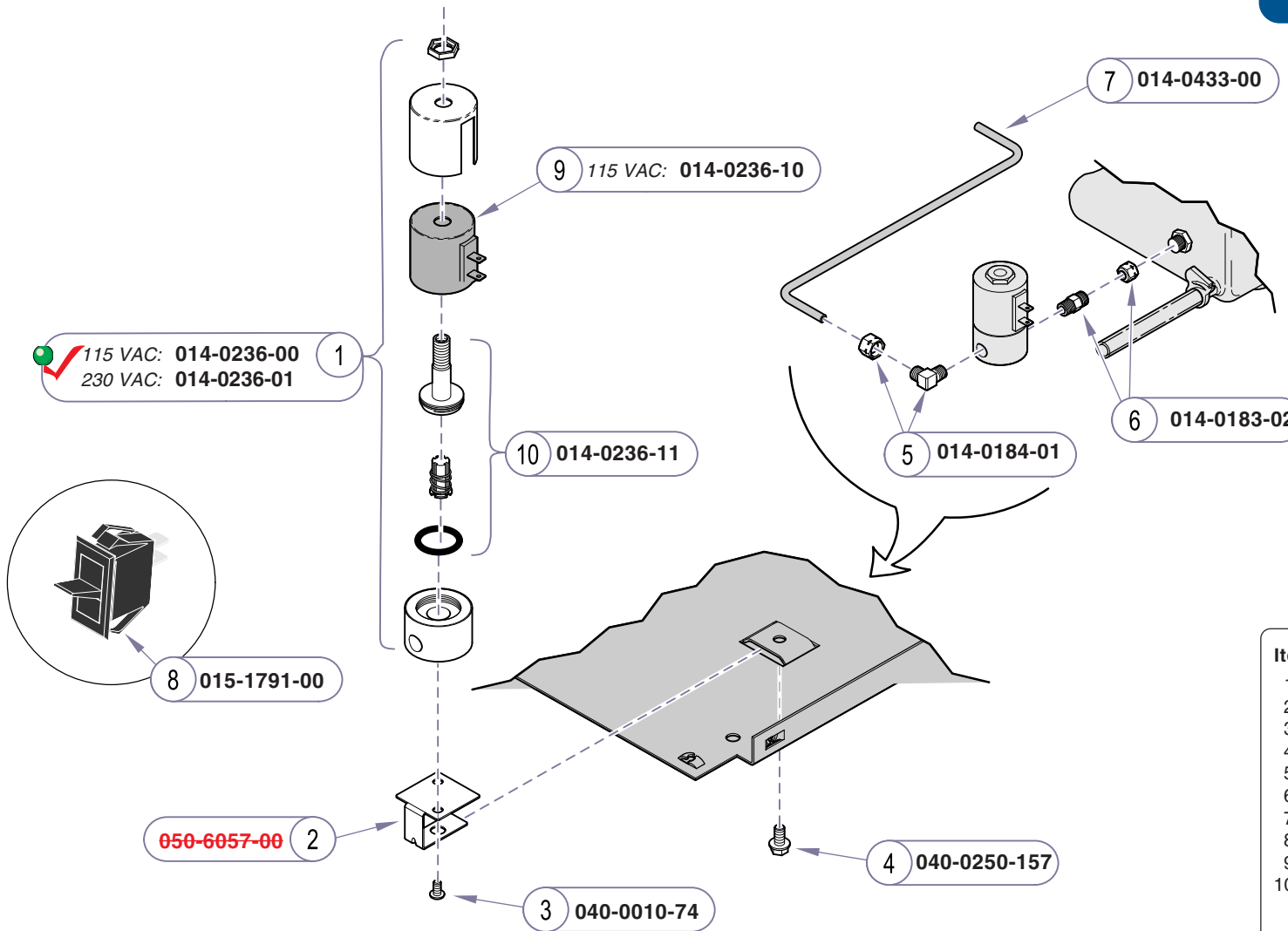

Item	Description	Qty.
1	Fill/Vent Valve	1
2	Mounting Bracket.....	1
3	Screw (#10-32 x 3/8")	2
4	Bolt (1/4-20 x 1/2")	2
5	Elbow Fitting	1
6	Male Fitting (3/8").....	1
7	Tubing (NLA)	1
8	Fill / Vent Switch	1
9	Replacement Coil.....	1
10	Replacement Kit (Includes plunger, guide, and seals)	1

Always Specify Model & Serial Number

MA674605i

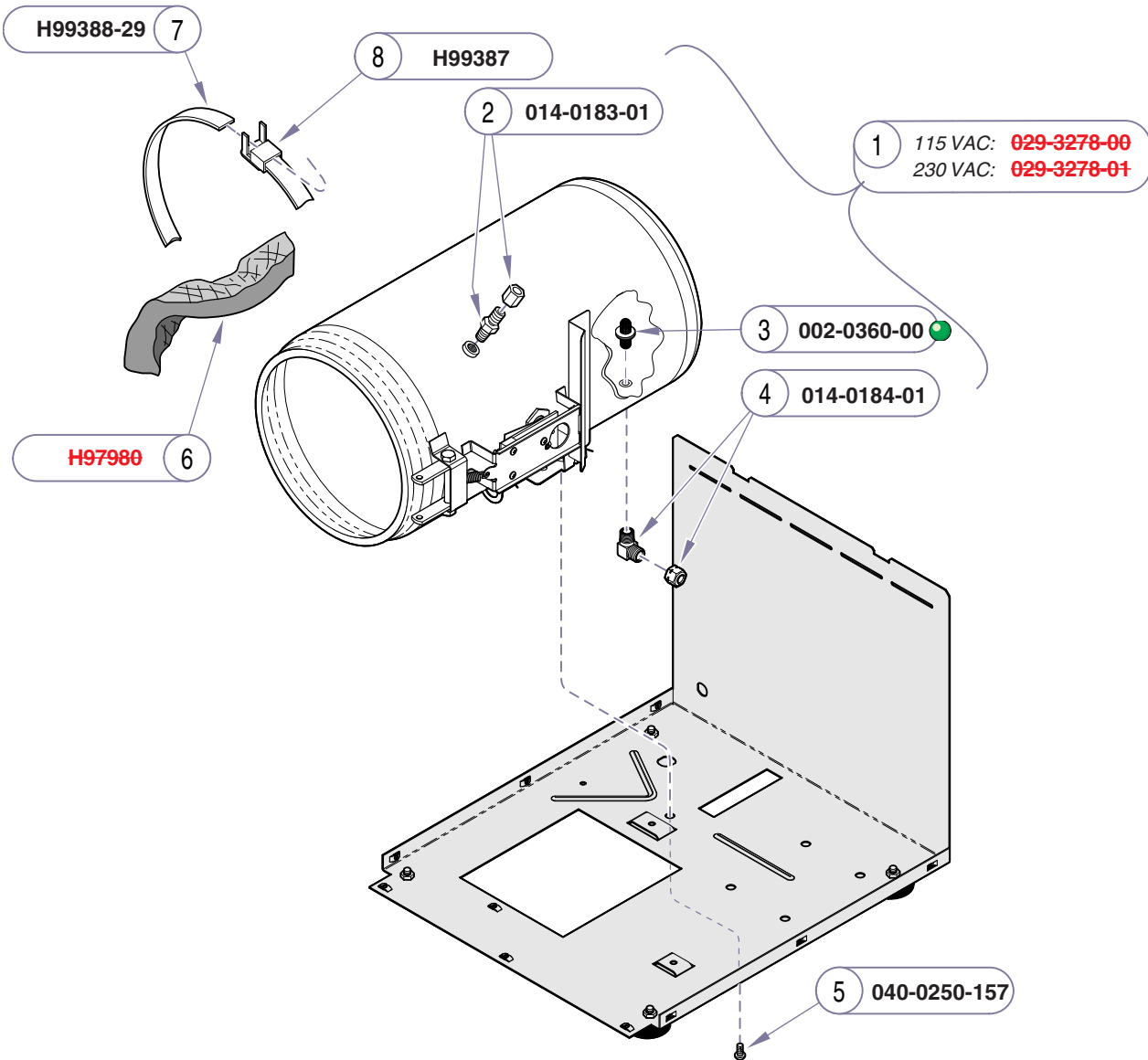

Refer To:	Page
Operation & Troubleshooting	A-1
Component Testing / Repair	B-1
Access Procedures	C-1
Wiring Diagrams	D-1
Exploded Views / Part Numbers ..	E-1

Item	Description	Qty.
1	Chamber Assembly - complete <i>includes items 2 thru 4 & the following:</i>	1
	• Heating Element & Thermostats (2)	
	• Temperature Regulator Assembly	
	• Door Hinge & Door Gasket	
	• Timer Buzzer	
2	• Compression Fitting	1
3	• Filter Screen	1
4	• Elbow Fitting	1
5	Screw	1
6	Insulation	1
7	Banding Strap	2
8	Banding Clip	2

Always Specify Model & Serial Number

MA676601i

Models: | M7 (-020 thru -022) |
 Serial Numbers: | all |

Chamber Components

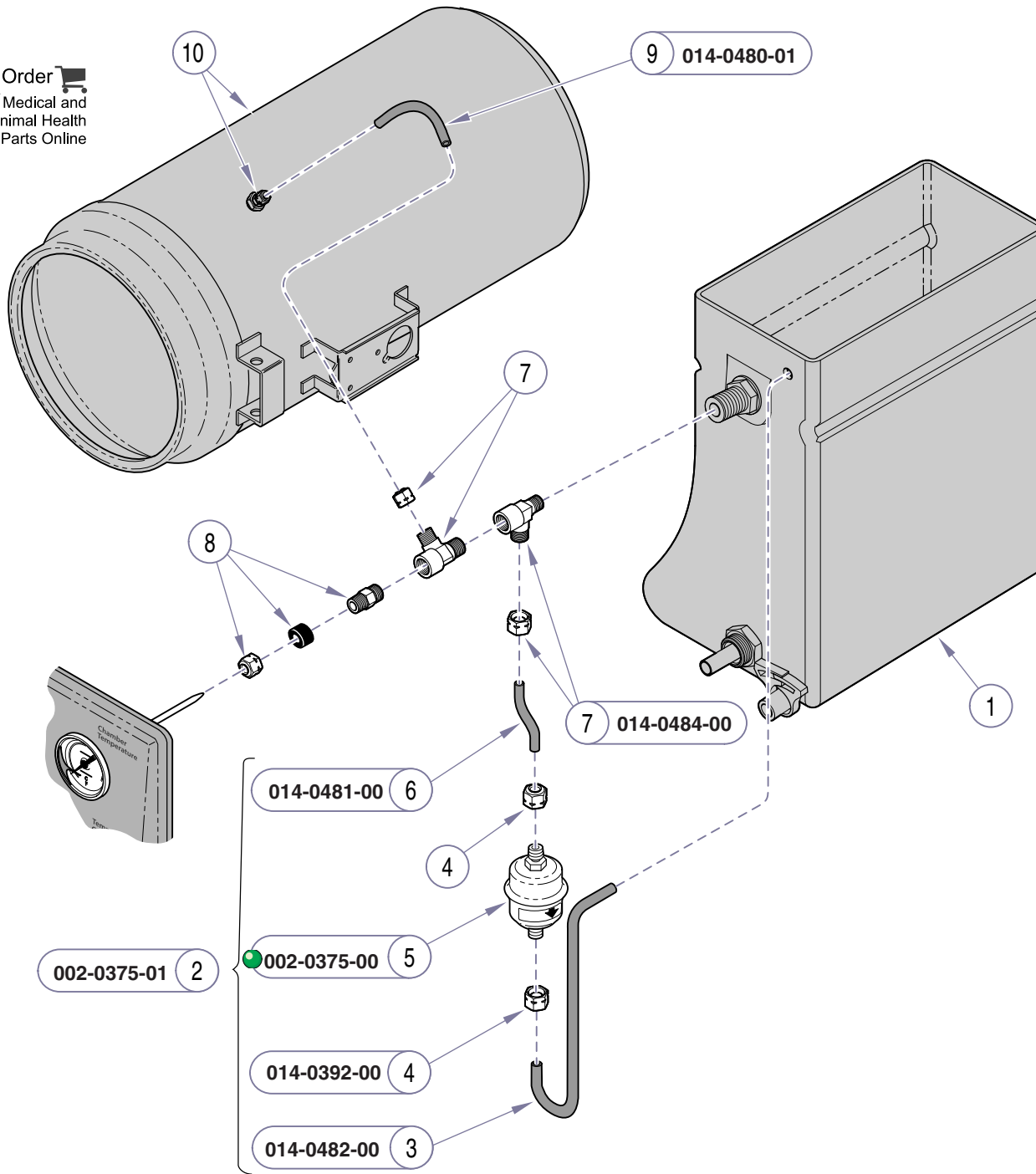

Refer To:	Page
Operation & Troubleshooting	A-1
Component Testing / Repair	B-1
Access Procedures	C-1
Wiring Diagrams	D-1
Exploded Views / Part Numbers ..	E-1

Item	Description	Qty.
1	Refer to: <i>Reservoir</i>	Ref
2	Bellows Kit	1
3	• Tube	1
4	• Compression Nut	2
5	• Bellows	1
6	• Tube	1
7	• Compression Fitting	2
8	Refer to: <i>Front Panel Components</i>	Ref
9	Tube	1
10	Refer to: <i>Chamber Components</i>	Ref

Always Specify Model & Serial Number

MA675602i

Bellows & Plumbing

Models: | *M7 (-020 thru -022)*
Serial Numbers: | *all*

Refer To:	Page
Operation & Troubleshooting	A-1
Component Testing / Repair	B-1
Access Procedures	C-1
Wiring Diagrams	D-1
Exploded Views / Part Numbers ..	E-1

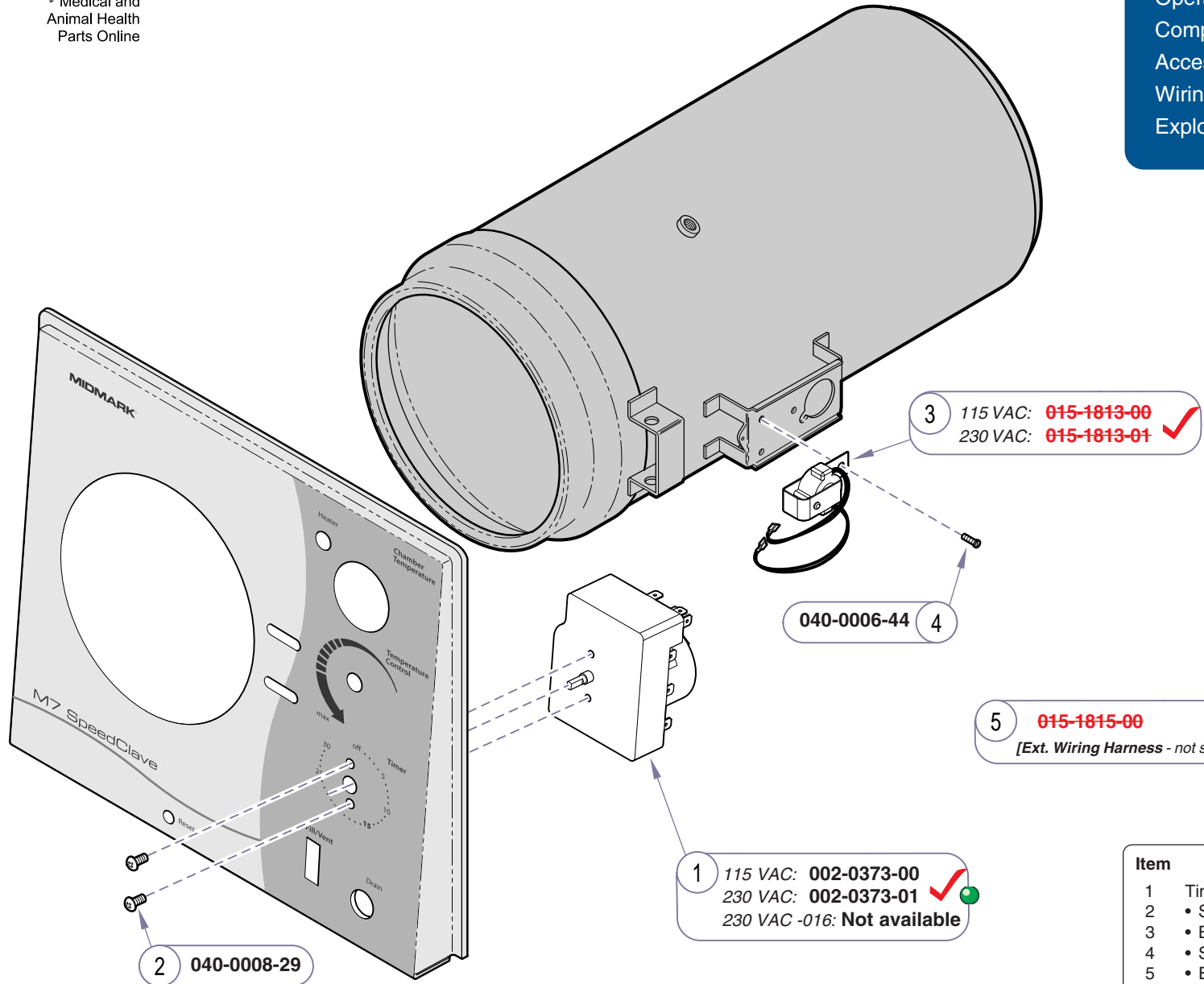

3 115 VAC: **015-1813-00** ✓
 230 VAC: **015-1813-01** ✓

040-0006-44 4

5 **015-1815-00**
 [Ext. Wiring Harness - not shown]

1 115 VAC: **002-0373-00** ✓
 230 VAC: **002-0373-01** ✓
 230 VAC -016: **Not available**

2 **040-0008-29**

Item	Description	Qty.
1	Timer Assembly Kit (incl. items 2 thru 5)	1
2	• Screw (#8-32 x 5/16")	1
3	• Buzzer	1
4	• Screw (#6-32 x 7/16")	1
5	• Extended Wiring Harness - not shown (required for older units only)	1

Always Specify Model & Serial Number

MA671802i

Models: **M7 (-020 thru -022)**
 Serial Numbers: **all**

Timer / Buzzer

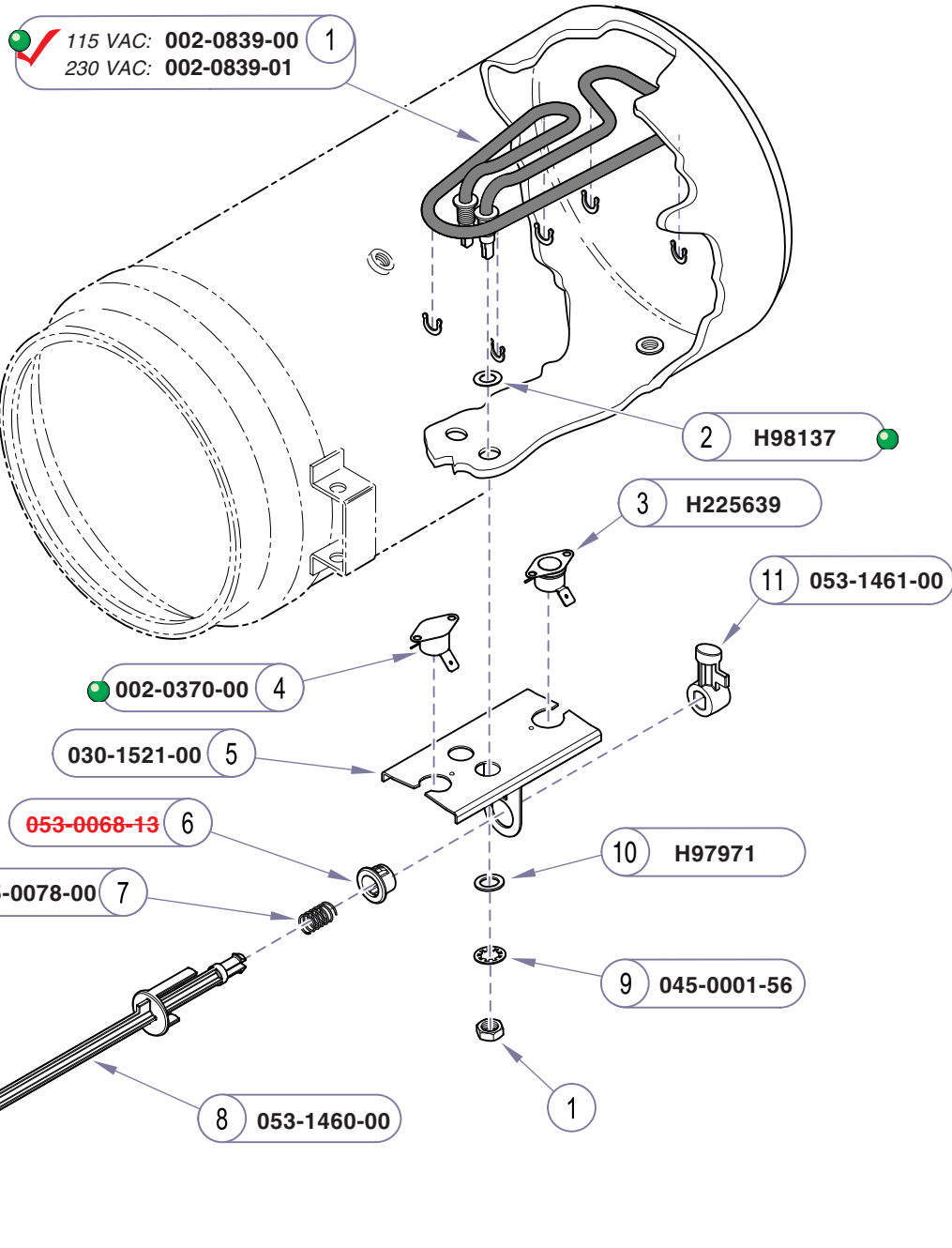

✓ 115 VAC: **002-0839-00** 1
 230 VAC: **002-0839-01**

Refer To:	Page
Operation & Troubleshooting	A-1
Component Testing / Repair	B-1
Access Procedures	C-1
Wiring Diagrams	D-1
Exploded Views / Part Numbers ..	E-1

Item	Description	Qty.
1	Heating Element Kit (includes nuts, e-clips & item 2)	1
2	• Gasket	2
3	Overheat Thermostat (manual-reset)	1
4	Overheat Thermostat (auto-reset)	1
5	Bracket	1
6	Bushing	1
7	Spring	1
8	Reset Rod	1
9	Lockwasher	2
10	Washer	2
11	Reset Button Actuator	1

Always Specify Model & Serial Number

MA673903i

**Heating Element &
 Thermostats**

Models: | **M7 (-020 thru -022)**
Serial Numbers: | **all**

Refer To:	Page
Operation & Troubleshooting	A-1
Component Testing / Repair	B-1
Access Procedures	C-1
Wiring Diagrams	D-1
Exploded Views / Part Numbers ..	E-1

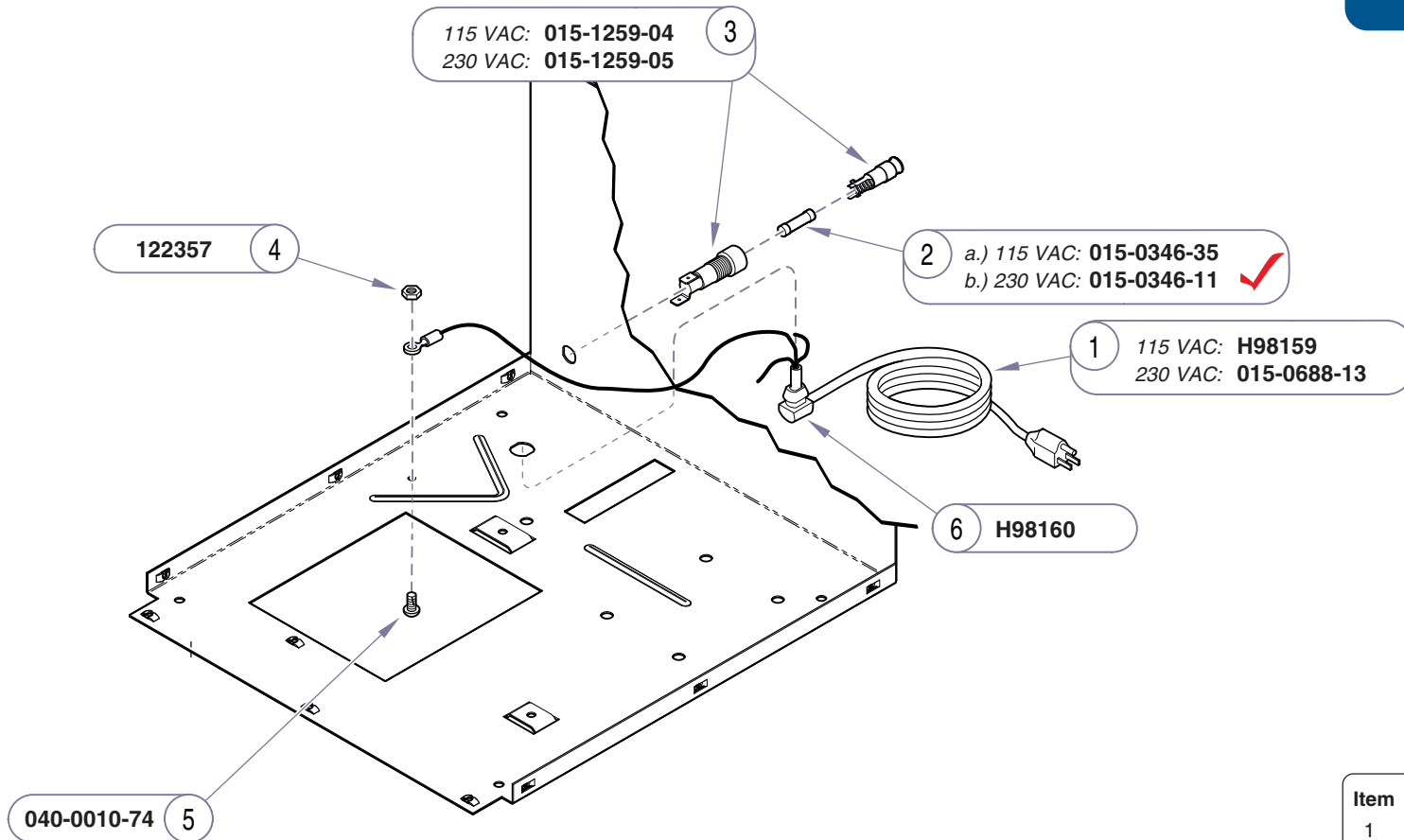

Item	Description	Qty.
1	Power Cord	1
2	Fuse:	
	a) 12A, 250V, Fast-Acting, 1/4" x 1-1/4" ...	1
	b) 8A, 250V, Fast-Acting, 5mm x 20mm ..	1
3	Fuse Holder	1
4	Screw (#10-32 x 3/8")	1
5	Keps Nut	1
6	Strain Relief	1

Always Specify Model & Serial Number

MA677201i

Models: | M7 (-020 thru -022) |
Serial Numbers: | all |

Power Cord / Fuse

Refer To:	Page
Operation & Troubleshooting	A-1
Component Testing / Repair	B-1
Access Procedures	C-1
Wiring Diagrams	D-1
Exploded Views / Part Numbers ..	E-1

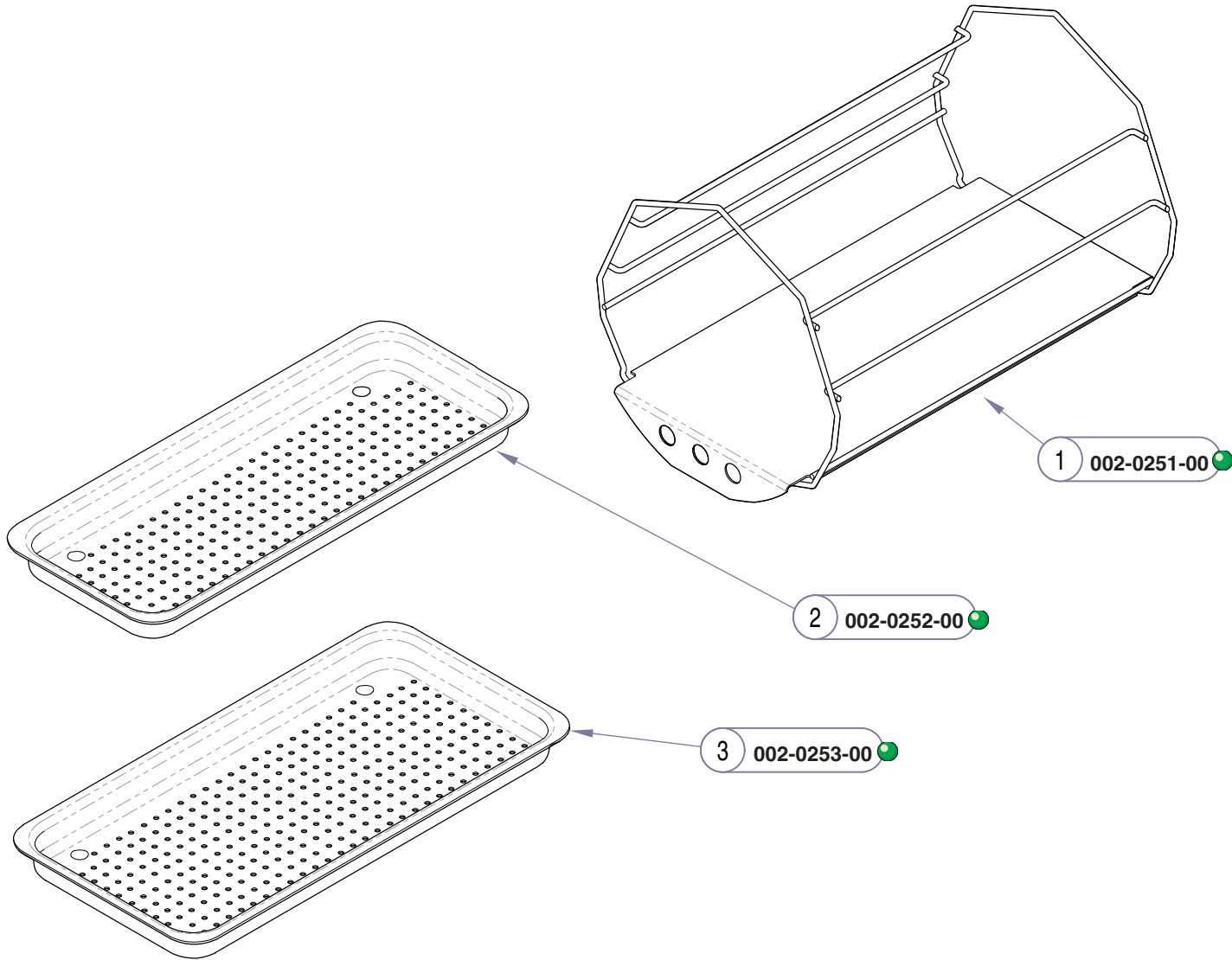

1 002-0251-00

2 002-0252-00

3 002-0253-00

Item	Description	Qty.
1	Tray Rack	1
2	4 inch Tray	1
3	5 inch Tray	2

Always Specify Model & Serial Number

SA102200i

Rack & Trays

Models: | M7 (-020 thru -022) |
Serial Numbers: | all |

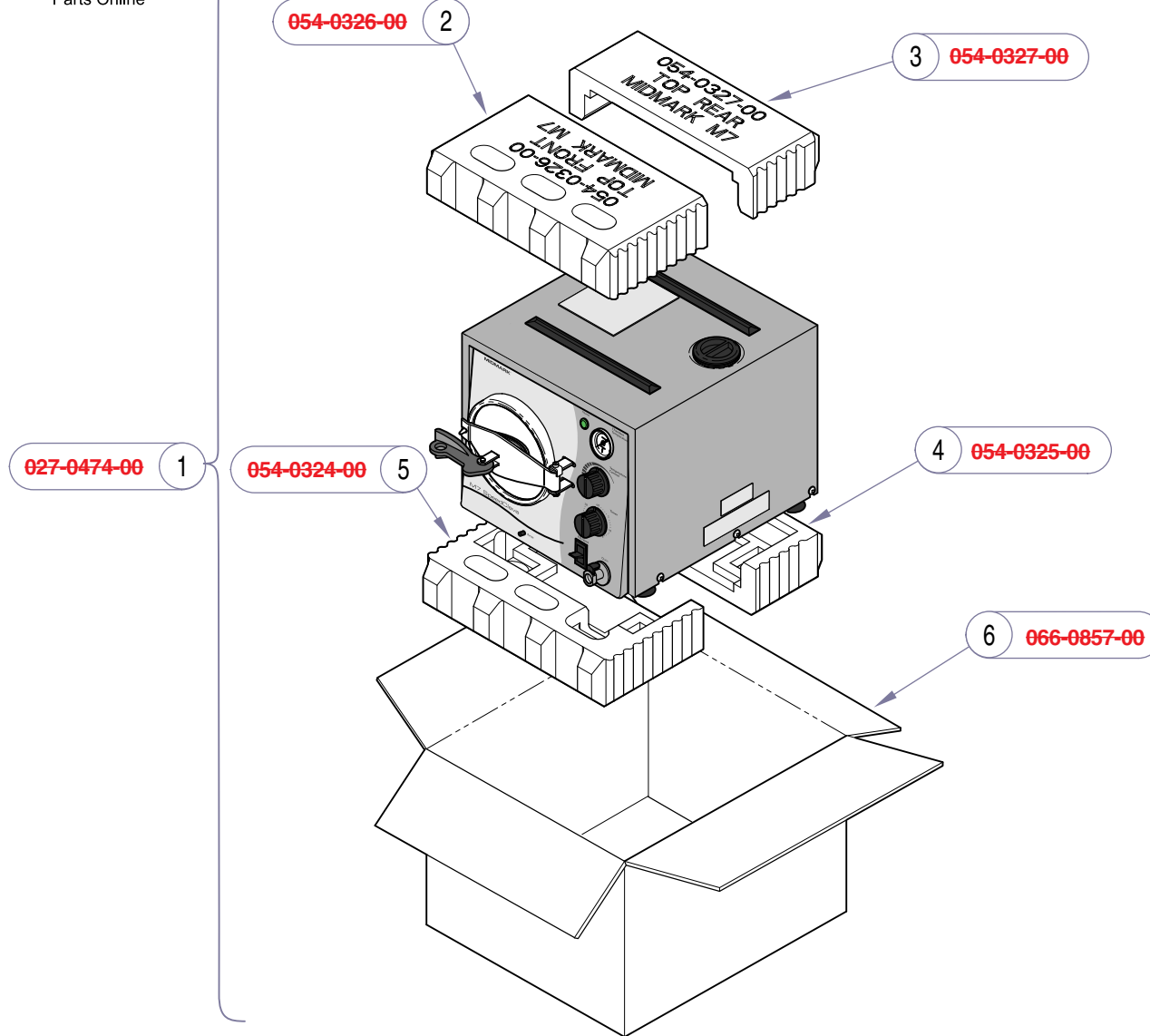

Refer To:	Page
Operation & Troubleshooting	A-1
Component Testing / Repair	B-1
Access Procedures	C-1
Wiring Diagrams	D-1
Exploded Views / Part Numbers ..	E-1

Item	Description	Qty.
1	M7 Packaging Kit - Generic (includes items 2 thru 8)	1
2	• Top Front Pad	1
3	• Top Rear Pad	1
4	• Bottom Rear Pad	1
5	• Bottom Front Pad	1
6	• Carton	1
7	• Sterilizer Cleaner (<i>not shown</i>)	1
8	• SDS Sheet (<i>not shown</i>)	1

Always Specify Model & Serial Number

MA514703i

Models: | M7 (-020 thru -022) |
Serial Numbers: | all |

Packaging

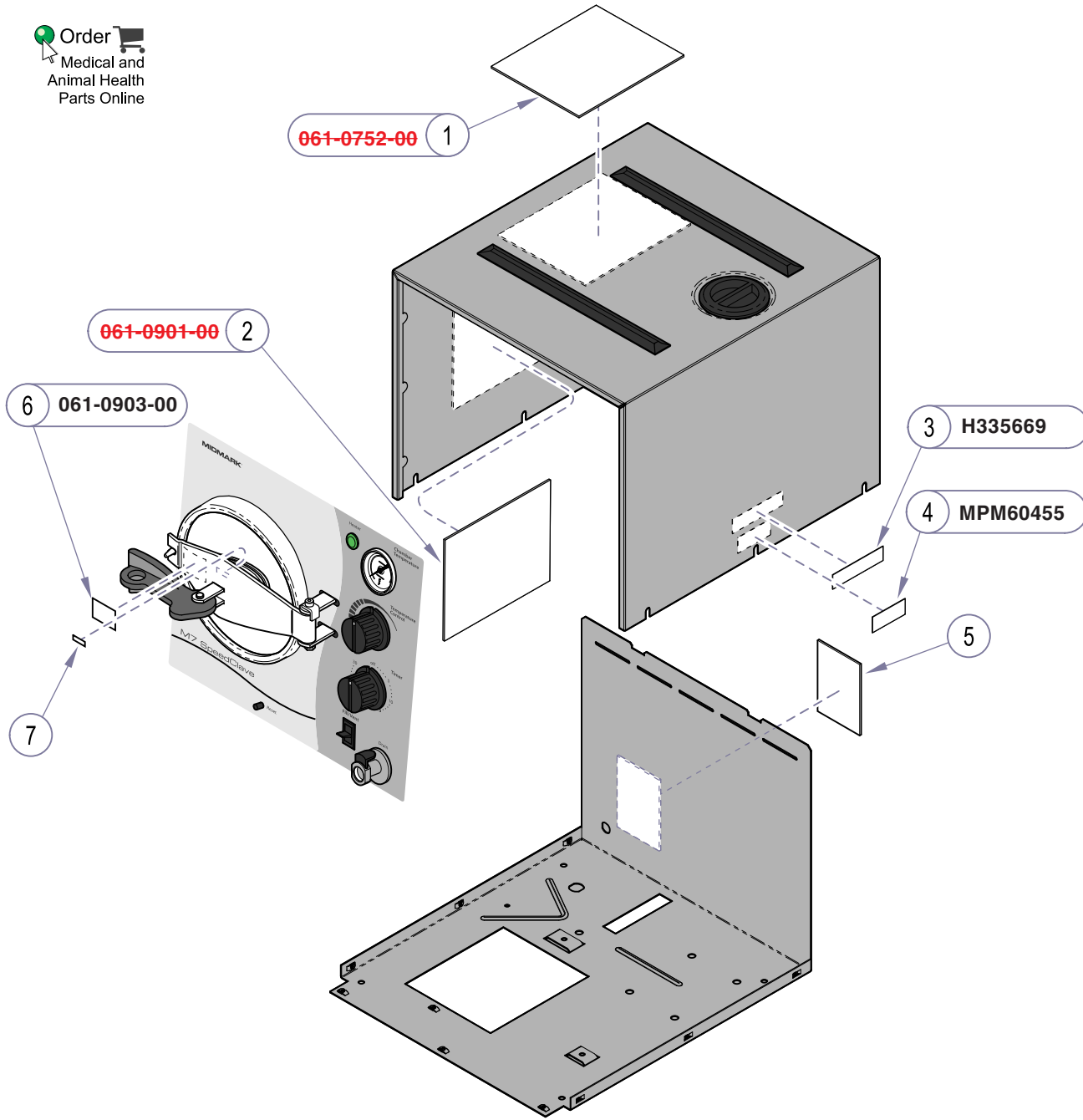

Refer To:	Page
Operation & Troubleshooting	A-1
Component Testing / Repair	B-1
Access Procedures	C-1
Wiring Diagrams	D-1
Exploded Views / Part Numbers ..	E-1

Item	Description	Qty.
1	Operating Instructions Plate	1
2	Wiring Diagram Label	1
3	Warning Label	1
4	Caution Label	1
5	Serial Number Label (<i>large- n/a</i>)	1
6	Caution HOT Label	1
7	Serial Number Label (<i>small - n/a</i>)	1

Always Specify Model & Serial Number

MA674302i

Labels & Decals

Models: | *M7 (-020 thru -022)* | | | |
Serial Numbers: | *all* | | | |

Subject to change without notice.
Refer to www.Documark.com for latest revision.

Midmark Corporation
60 Vista Drive
P.O. Box 286
Versailles, OH 45380-0286
Phone: 937-526-3662
Fax: 937-526-5542
www.midmark.com

