

Configura[®]Advance
by Accora

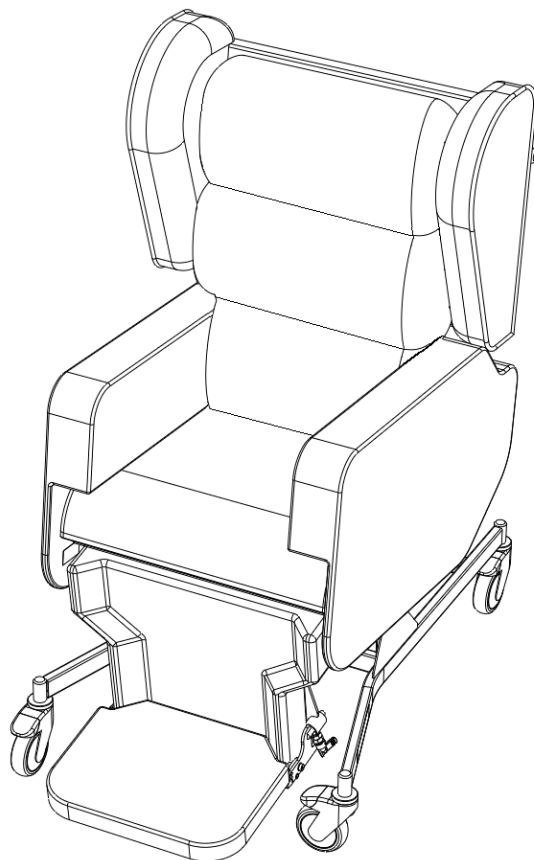

Configura Advance Chair Instruction Manual

IFU-SC3-001US Rev 02
March 2021

Accora

Contents

Title	Page
Welcome	2
General warnings	3
1. Means of delivery	4
2. Safety instructions	4
3. Intended use	4
4. Technical specification	4
5. Accessories	5
6. Assembly	6
7. Chair adjustment	8
8. Footplate operation & adjustment	11
9. Controls	12
10. Using the castor brakes	14
11. Functionality check	16
12. Cleaning & disinfection	16
13. Troubleshooting	16
14. Storage	16
15. Daily inspection	17
16. General maintenance	17
17. Guarantee	17
18. Disposal	17
19. Table of symbols	18
20. Contact details	18

Before using the Configura Advance chair, you must read and understand the instructions in this user manual. All actions and handling of the chair must be performed in accordance with the instructions in this manual.

Any actions that are inconsistent with the manual are performed at your own risk and Accora shall not be liable for any injury or damage. Please ensure that the manual is available to users and operators throughout the chair's service life.

Welcome

Dear Customer,

Thank you for purchasing an Accora healthcare product. We feel sure that this product will exceed your expectations.

This manual is important for understanding how to use your new Configura Advance chair; please read it before use. If you need further information, or require the information in a different format, please contact Accora.

See Contact Details in Section 20.

General

For USA, the Configura Advance chair is classified as a Class 1 Medical Device.

For Europe, the Configura Advance chair is classified as a Class 1 Medical Device in accordance with the Medical Device Regulation 2017/745.



Notice to User

If a serious incident occurs in relation to this medical device, affecting the user or the patient, then the user or patient should report the serious incident to the medical device manufacturer (or distributor) and, in the European Union, the user should also report the serious incident to the Competent Authority in the member state where they are located.

EC REP

Accora Ltd, 38 Main Street,
Swords, Co. Dublin, Ireland, K67 E0A2
T: +353 (0)1 695 0614

Design Policy and Copyright

® and ™ are trademarks belonging to Accora Ltd unless otherwise stated. As our policy is one of continuous improvement, we reserve the right to modify designs without prior notice. © Accora Ltd 2020.

GENERAL WARNINGS

1. Keep this Instruction Manual available for future reference.
2. These instructions must be observed to ensure the safe and effective use of this chair and the safety of users and carers.
3. This chair must be assembled, positioned and used in accordance with these instructions.
4. The safety features for operating the chair and instructions concerning the chair must be strictly observed.
5. The chair must not be exposed to smoke, naked flame, extreme temperature, flammable gases or other hazardous substances or situations.
6. Accora shall not be held liable for any damage, injuries or accidents arising from unauthorised modifications, non-genuine spare parts, negligence or use that is at variance with this manual which can result in serious injury or death.
7. Keep children and pets away from this chair unless supervised by an adult as there is a risk of injury and/or choking on small parts.
8. When routing cables for other electronic equipment used with the chair (e.g. air cushion pump), ensure cables cannot be squeezed, crushed or damaged by the moving parts of the chair.
9. It is essential to consult Accora in advance if you wish to use the chair for any purpose outside the use detailed in this manual.
10. When repairing the chair, only original materials and components may be used, otherwise Accora cannot guarantee against any damage that might occur.
11. Inappropriate routing of accessory cables, e.g. cushion pump cable, could lead to dangerous electrical hazards if squeezed or crushed between moving parts. The chair must not be used if there is any visible damage to any cables.
12. Do not move the chair when it is in the forward tilt position.
13. This chair is not recommended for users outside the weight specifications detailed in Section 4.
14. Do not modify this chair without the authorisation of Accora.
15. Before operating this chair, ensure the patient is safely positioned to reduce the risks of falling, entrapment and imbalance.
16. Patients, or users, should be risk assessed to ensure they are able to understand this manual and to operate the Configura Advance chair safely without risk to themselves or others.
17. Patients or users should only be allowed to operate the chair independently if they are able to understand the safety instructions in this manual and have been risk assessed as appropriate to do so.
18. Patients, or users, must be risk assessed before using the chair to make sure that the chair is suitable for the patient/user.
19. Surface temperatures can increase when exposed to sunlight.
20. If the medical staff state that the patient's medical condition is inappropriate for the patient to be able to adjust the chair independently, the chair's position must only be adjusted by the carer.
21. The chair may not be used where there is a danger of explosion or in the presence of uncontained flammable liquids.
22. Damaged or torn fabric may cause injury.
23. It is recommended that a patient does not smoke while using the chair.
24. The chair is not suitable for transporting patients outside e.g. in vehicles or aircraft.

1. Means of delivery

The Configura Advance chair is supplied boxed. An inspection must take place upon receipt to ensure the delivery is complete and undamaged.

Any missing parts, faults or damage must be reported immediately to the carrier and Accora in writing.

2. Safety instructions

1. Before using the chair, you must read the instruction manual and use the chair in accordance with it.
2. The chair must not be used if faults have been detected on it that may injure the patient, staff or a third person.
3. The chair must only be operated by persons who are able to operate it in accordance with this manual.
4. Users must make the patient aware of the control functions that apply to the patient, subject to an assessment by a professional.
5. Before using the chair, the user should understand the chair and its functionality.
6. The safe working load, as specified in Section 4, must never be exceeded.
7. If a patient is left alone in the chair, the chair castors must be locked as an unlocked chair can cause injury to a patient who leaves the chair or changes position.
8. When operating the moving parts of the chair, care must be taken to ensure that the patient, other people and objects do not become trapped.
9. The chair may not be used where there is a danger of explosion or in the presence of uncontained flammable liquids.

3. Intended use

1. The Configura Advance chair is intended to be used as a portable chair with built in size, pressure and posture options in the acute, long-term care and homecare environments. The chairs are intended for patients who do not exceed the safe working load and height recommendations for the device.
2. The Configura Advance chair range is intended for use in primary healthcare environments where supervision can be provided if necessary, for example, long-term residential care, nursing homes or convalescent units. The Configura Advance chair may also be placed in private homes where there is unlikely to be 24-hour supervision by clinical

staff, but where the patient or caregiver is considered competent in its use.

3. A typical patient / user ranges from those who are physically dependent on caregivers for their mobility, social and daily care needs, through to rehabilitating patients.
4. Patients using the chair may also have declining cognitive awareness, with symptoms ranging from mild forgetfulness and poor concentration through to end-stage dementia.
5. Patients may require postural support for the accommodation, encouragement and management of good posture.

4. Technical specification

The table below lists the Configura Advance chair part numbers. Part numbers may be suffixed (US etc) to show regions.

Part number	Description
CHAIR-0-SC3-050	Advance chair, 125/150mm (5/6") castors, standard backrest, black vinyl/interliner, manual

General specification

Description	Value
Model name	SC3
Overall dimensions	700mm W x 880mm D x 1300mm H 27.6in W x 34.6in D x 51.2in H
Chair castor	2x 125mm (5") and 2x 150mm (6") with brake
Safe Working Load	160kg / 352lbs / 25st
Maximum Patient Weight	160kg / 352lbs / 25 st
Mass of Chair	85.1kg / 188lbs
Flammability	Interliner fabric: TB117 - 2013
Expected service life	Typically 7 years

Condition	Temperature Range	Relative Humidity	Atmospheric pressure
Operating	+10°C to +25°C (+50°F to +77°F)	30% to 75% (Non-condensing)	700 hPa to 1060 hPa
Transport/storage	-20°C to +50°C (-4°F to +122°F)		

Environmental information:

Note: Always store out of direct sunlight. If the chair is stored in conditions outside the normal operating range, it should be allowed time to stabilise, in normal operating conditions, before use.

Configura Advance Chair position setting ranges:

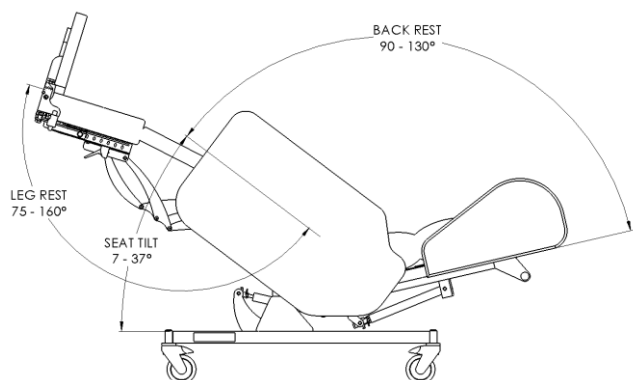

Standard position range settings

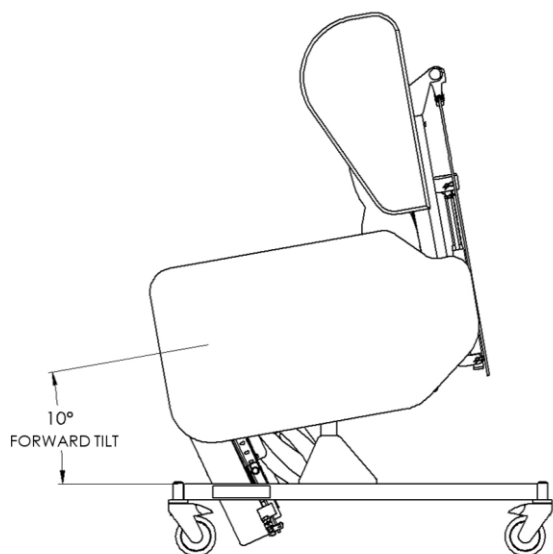

Forward tilt position setting

Key parts of the chair:

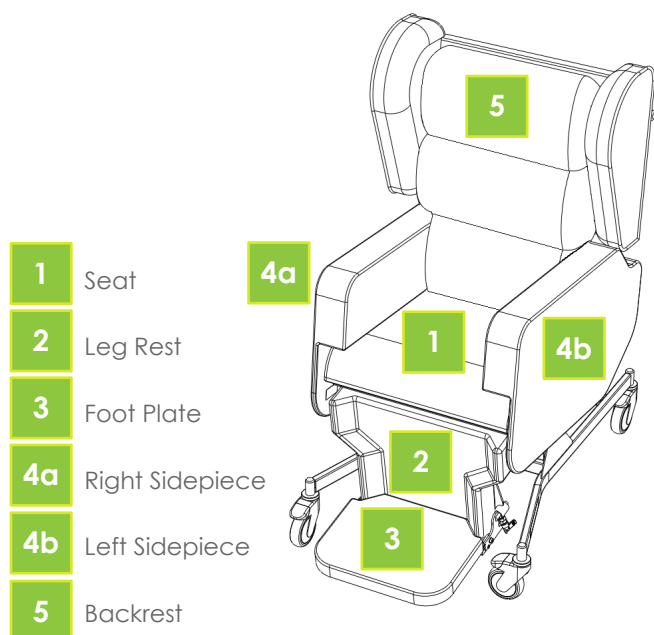

5. Accessories

The following accessories are black vinyl or vapour permeable fabric and have an interliner.

Part number	Description
BRPOSKT-0-SC1-050	Postural backrest includes all metal frames and cushions
HRPF-0-SC1-060	Backrest profiled headrest
DRPSIDKT-0-SC1-050	Dropdown sidepieces and covers, set of 2
DRPARM-0-SC1-250	Dropdown armrests, 400-550mm (16-22"), set of 2
DRPARM-0-SC1-050	Dropdown armrests, 350-500mm (14-20"), set of 2
DRPARM-0-SC1-150	Dropdown armrests, 400-550mm (18-22"), narrow, set of 2
EXTLAT-0-SC1-060	External laterals, set of 2
TRAY-0-SC1-000	Tray

For more information, refer to the relevant instruction manual or contact Accora.

6. Assembly

WARNING

Assembly **MUST** be carried out by suitably trained and qualified personnel.

All functions **MUST** be tested and approved after assembly by suitably trained and qualified personnel.

Assembly **MUST** take place in a clear, uncluttered area and children and pets should be kept away.

If chair has become soiled or contaminated during transit refer to cleaning and disinfection instructions.

1. Check that the delivery is complete and whether any visible damage has occurred to the chair during transport.
2. Remove the cardboard box and other packaging and the chair should appear as fig 1.
3. The following components should be present:
 - A. Chair frame assembly
 - B. Right Sidepiece
 - C. Left Sidepiece
 - D. 3 x Backrest cushions
 - E. Footplate
 - F. Instruction manual
4. Remove the R-clip (Fig 2, Item 1), then remove the clevis pin (Fig 2, Item 2).
5. Rotate the backrest upward and hold in place. Align the mounting hole at the bottom of the gas strut (Fig 3, Item 2) and the mounting hole at the bottom of the backrest lockout slide (Fig 3, Item 3) with the clevis at the back of the main frame (Fig 3, Item 1). Ensure the Tilt-in Space operating cable (Fig 3, Item 4) is routed between the backrest and the backrest actuator assembly.

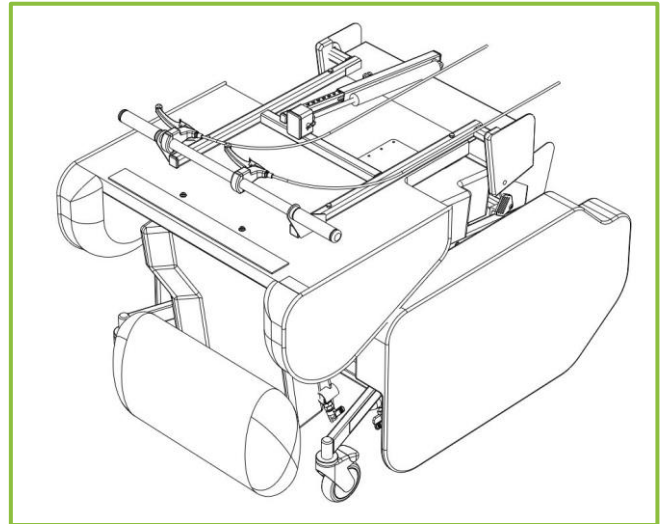

Figure 1 - Chair as delivered (side pieces are loose)

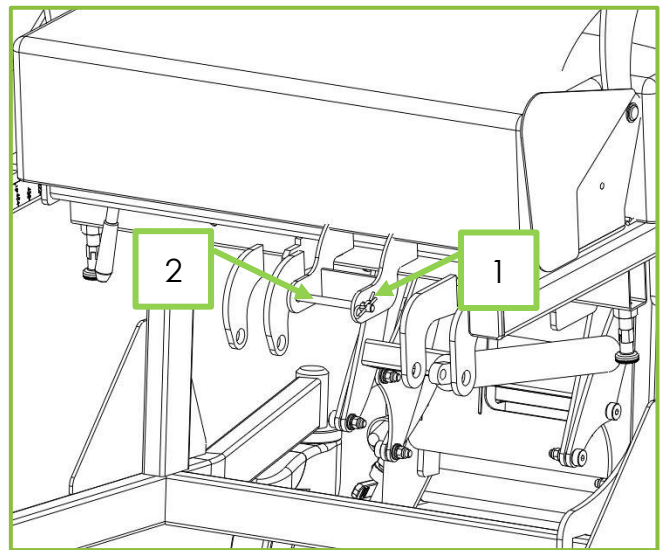

Figure 2 – Backrest clevis pin

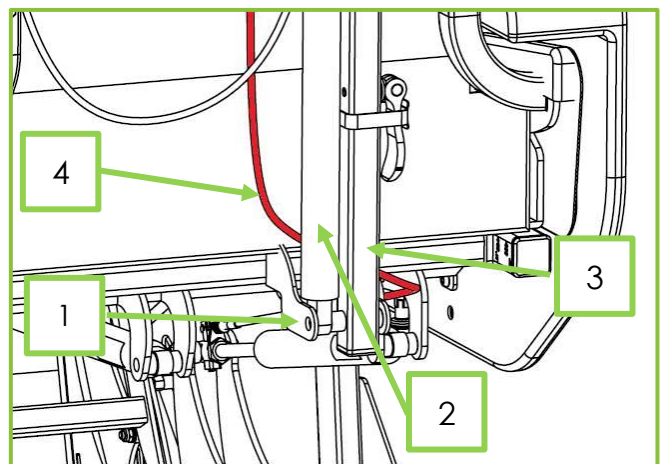

Figure 3

6. Insert the clevis pin (Fig 4, Item 1) through the clevis at the back of the main frame, the gas strut and the backrest lockout slide. Secure the pin with the R-clip (Fig 4, Item 2).

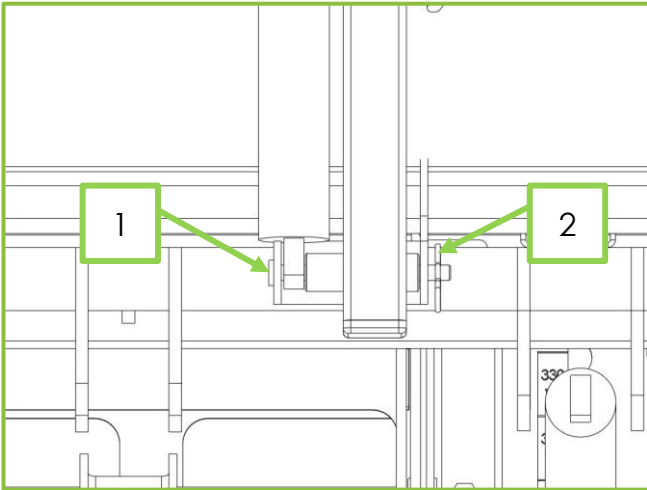

Figure 4

7. There is a cover attached to the bottom of the backrest to cover the backrest hinge. To fit this cover, place the first part of the cover (Fig 5, Item 1) over the rear part of the hinge protection plate (Fig 5, Item 2), then pull the front part of the cover (Fig 5, Item 3) down over the hinge.

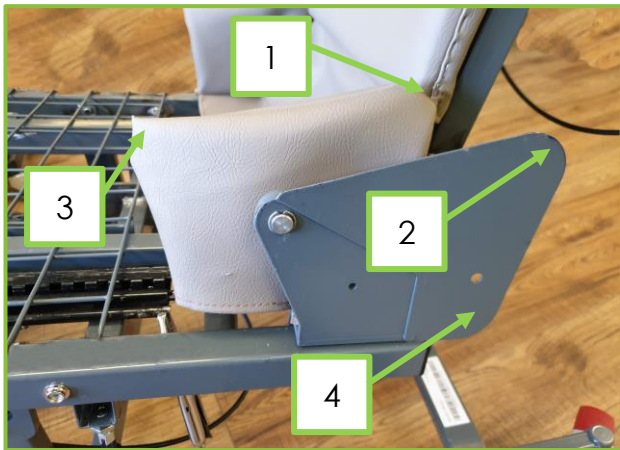

Figure 5 – (Seat cushion shown removed for clarity.)

8. Figure 6 shows the backrest hinge cover from the inside. Place the lower pocket of the backrest hinge cover (Fig 6, Item 1) over the lower part of the hinge protection plate (Fig 5, Item 4) to secure the hinge cover in place.
9. Repeat steps 7 and 8 to secure the cover on the other side.
10. Secure the backrest cushions to the backrest with the Velcro flaps. Each cushion is attached to the backrest with the Velcro flap at the top of the cushion. The top cushion has a double width Velcro flap and is marked Pillow – Top. The middle and bottom cushions are identical.
11. Ensure the female poppers on the overlay are engaged on the male poppers on the frame, 3 EA on left- and right-hand side. (Fig 7, Item 1)
12. To fit the sidepieces, pull out the plunger located under the seat on one side of the chair (Fig 8, Item 1) and rotate it through 90 degrees to lock it open. Fig 9 shows the plunger locked open.
13. Undo the hand screw (Fig 8, Item 2).



Figure 6

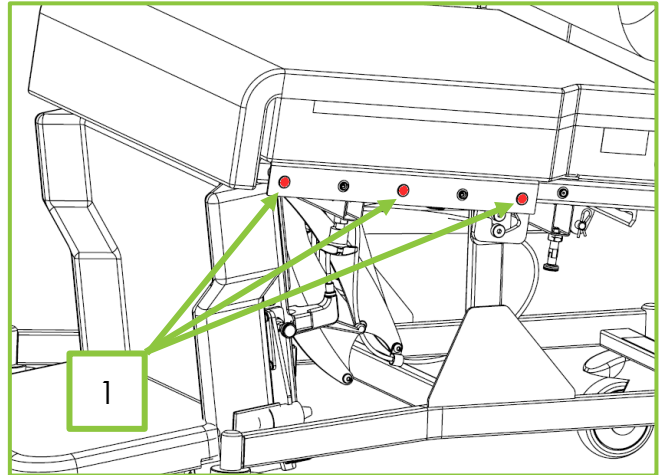

Figure 7

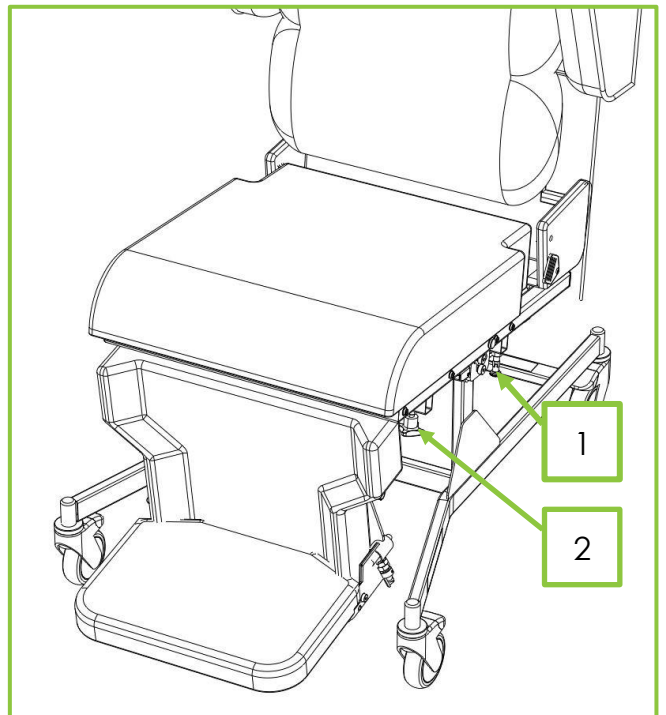

Figure 8

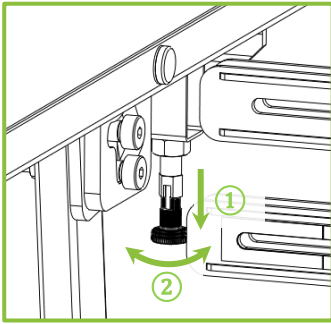

Figure 9

14. Locate the two sidepiece fixing bars into the chair frame. Push the sidepiece all the way in (Fig 10) and release the plunger by rotating it until the cap engages with the base (Fig 11).

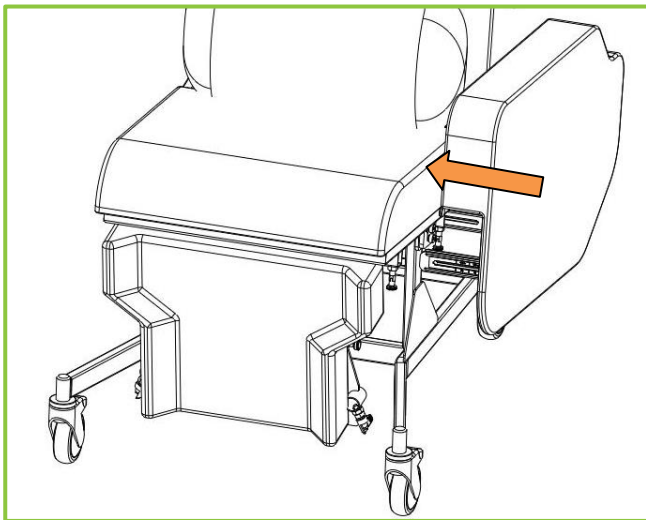

Figure 10

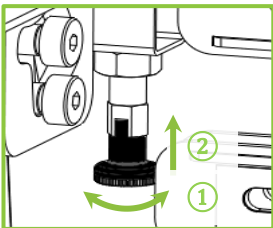

Figure 11

15. Ensure the plunger is engaged by moving the sidepiece in and out – the sidepiece should not move.
16. Tighten the hand screw to secure the sidepiece.
17. Repeat steps 12 to 16 to fit the other sidepiece.
18. Carry out a functional check (see section 11).

7. Chair adjustment

WARNING

Adjustment **MUST** be carried out by suitably trained and qualified personnel.

A clinical assessment and risk assessment **MUST** be carried out by suitably trained and qualified personnel before adjustments are made to the chair.

Do not adjust the width, depth or height of the chair when a patient or user is in the chair.

The Configura Advance chair can be adjusted in the following areas:

1. **Chair Width range** – The chair width has 4 widths that can be set, adjusted using the armrest locking plungers and hand screws. The available width dimensions are:
 - 400 mm (16")
 - 450 mm (18")
 - 500 mm (20")
 - 550 mm (22")
2. **Chair Depth range** – The chair depth can be adjusted in 9 increments from approximately 422 mm (16") to 512 mm (20"). The depth is adjusted using a lever and slide mechanism.
3. **Armrest Height range** – The armrest height can be set at 165mm (6.5"), 200mm (8") or 225mm (9"). The height is adjusted by changing the armrest bracket fitting position.
4. **Footplate Height range** – The footplate height can be adjusted from 330mm (13") to 533mm (21"). The height is adjusted using two plungers.
5. **Chair Seat Height range** – The Advance chair frame can be adjusted to give seat heights from the floor of 615mm (24.2") and 540mm (21.2").

Chair Width adjustment

1. Make sure a patient is not in the chair.
2. Make sure the brakes on all 3 locking castors are locked on (See section 10).
3. On one side of the chair, underneath the base of the sidepiece, locate the locking plunger (Fig 8, Item 1).
4. Pull the plunger out and rotate 90 degrees to lock the plunger open (Fig 9).
5. Loosen the hand screw (Fig 8, Item 2).
6. With two hands, pull or push the sidepiece until the desired measurement is achieved. The measurement can be read just inside the sidepiece at the front between the seat and the sidepiece (See Fig 12).
7. Pull the plunger out, rotate 90 degrees and let go to lock the plunger in position (Fig 11).

8. Move the sidepiece in and out to make sure that the plungers have locked the sidepiece in position.
9. Tighten the hand screw.
10. Adjust the opposite sidepiece in a similar manner to match the same measurement on both sides.

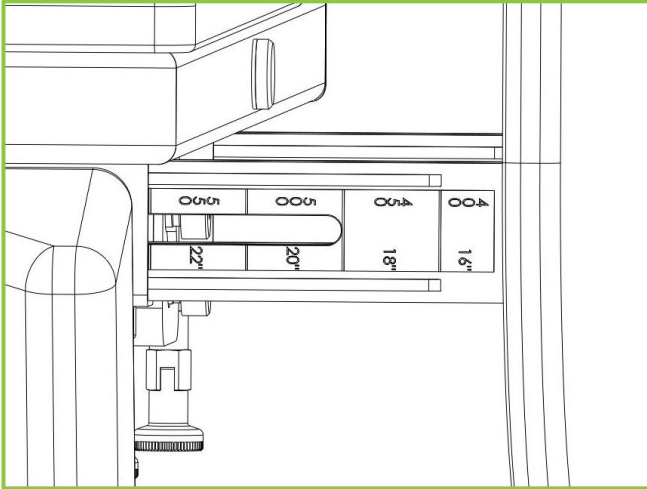

Figure 12

Chair Depth adjustment

1. Make sure a patient is not in the chair.
2. Make sure the brakes on all 3 locking castors are locked on (See section 10).
3. At the back of the chair, under the seat on the left-hand side, locate the depth adjustment lever (Fig 13, Item 1)
4. Turn the lever clockwise to release the backrest slide mechanism and move the backrest to the desired measurement with the other hand. The depth setting can be read off the scale on the back part of the seat frame (Fig 14, Item 1).

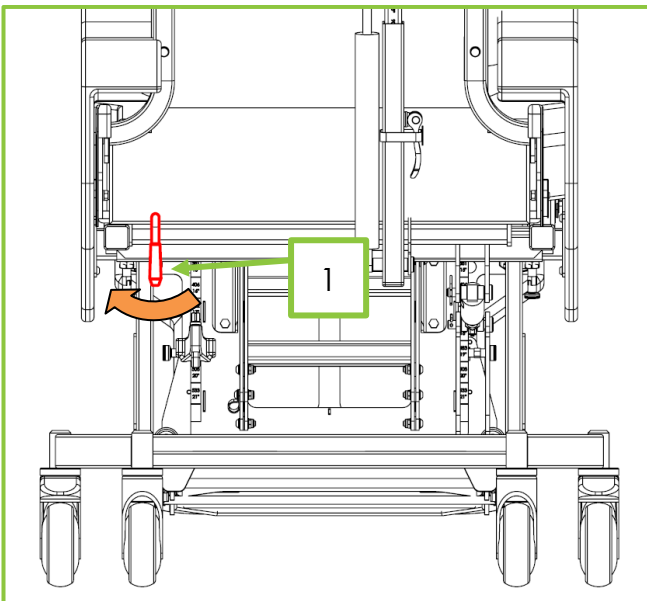

Figure 13

5. Release the depth adjustment lever and move the backrest in and out slightly to ensure the locking mechanism has engaged.

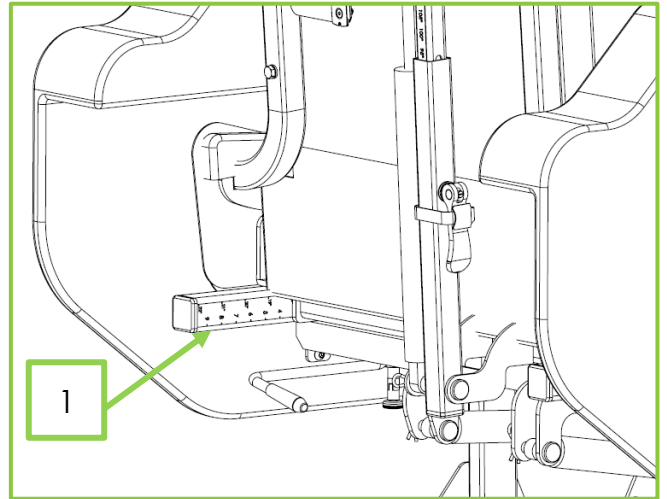

Figure 14

Armrest height adjustment

1. Make sure a patient is not in the chair.
2. Undo the hand screw and sidepiece locking plunger (Figure 8).
3. Pull the sidepiece from the chair seat frame, undo the screws (Figure 15) from the fixing bars.

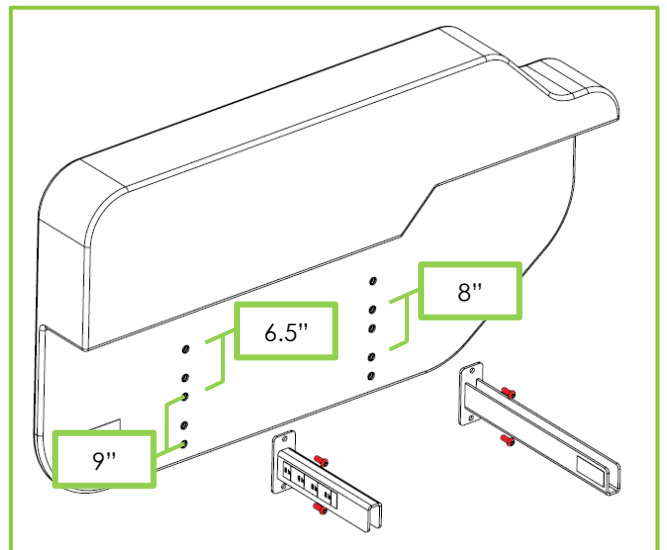

Figure 15

4. Locate the fixing bars to the desired position for armrest height, secure the fixing bars with screws. Refer to Figure 15 for armrest height position and fixing bar location.
5. Fit the sidepieces to the chair. Pull and rotate the locking plunger to lock the fixing bar, tighten the hand screws.

Footplate Height adjustment

1. Make sure a patient is not in the chair.
2. Make sure the brakes on all 3 locking castors are locked on (See section 10).

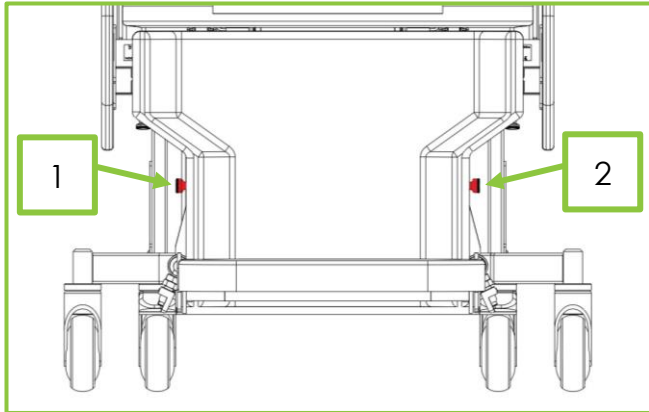

Figure 16

3. Locate the footplate height adjustment plungers on either side of the legrest (Fig 16, Items 1&2).
4. Pull and hold the caps of the two plungers to release the footplate height frame and move the footplate to the desired height measurement. The footplate height measurement can be read off the scale located at the rear of the legrest (Fig 17).
5. Release the caps of the plungers to lock the footplate height.
6. Ensure both plungers are locked and that they both read the same measurement off the scale.

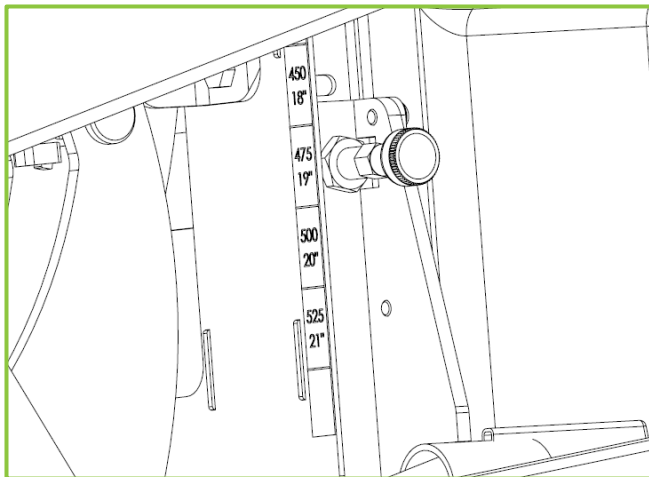

Figure 17

Seat Height adjustment

1. The chair is supplied on the high seat height position.
2. Make sure a patient is not in the chair.
3. Remove the footplate (See section 8) and place the chair carefully on its front.
4. Using a 13mm spanner and 5mm Allen key, undo and remove the Nylock nut and shoulder bolt (Fig 19, Item 1 and Item 2). Keep the bolt, washers, bushes, and nut for next use.
5. Using a 17mm spanner and 8mm Allen key, undo and remove two bolts, nuts, and washers on left-

hand and right-hand side of base frame (Fig 18; Fig 19, Item 3).

6. Move the base frame to the new position. Figure 18 shows the relative positions of the chair supports and the bolt positions.
7. Refit the bolts, nuts and washers taken out in step 5 in the new position (Fig 18; Fig 19, Item 3).
8. Refit the shoulder bolt, washers, bushes, and nut in the required hole of the base frame. (Fig 20).
9. Place the chair back on its wheels and refit the footplate (See section 8).

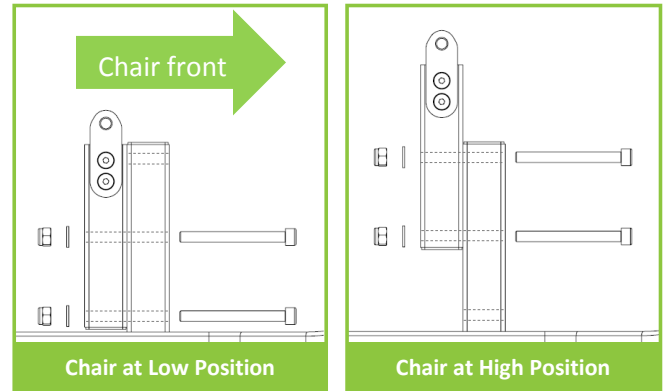

Figure 18 – Chair support fixings

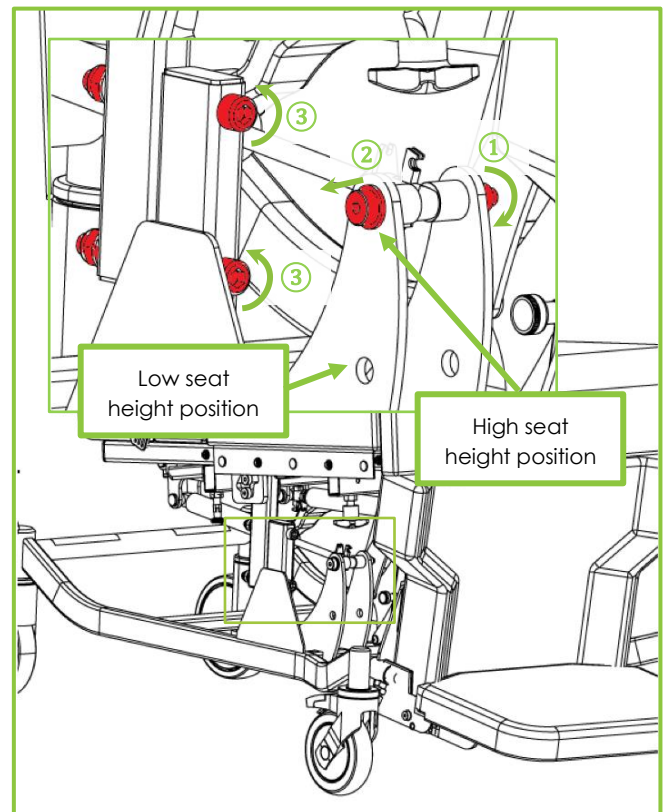

Figure 19 – Actuator and chair mounting

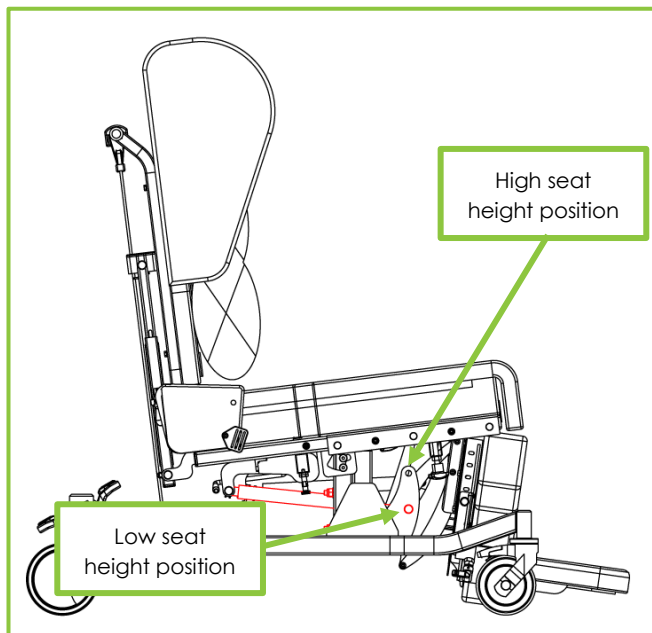

Figure 20 – Actuator mounting

Note: After any of these adjustments a functionality check must be carried out (See section 11).

8. Footplate operation & adjustment

WARNING

Always engage the castor brakes when the chair is stationary or left unattended.

Ensure the patient is in a stable sitting position while the footplate is adjusted, fitted or removed.

The Configura Advance chair is supplied with a removeable angle adjustable footplate. The footplate has 3 angle settings: 90°, 105° and 120°.

The height adjustment system of the footplate is separate from the footplate removal – for details on how to adjust the footplate height refer to section 9 of this manual. The footplate may be fitted, removed and adjusted with the patient in the chair. Ensure the patient is sitting securely and cannot slide out.

Operation – Fitting the Footplate

1. Ensure that the plungers that secure the footplate (Fig 21, Items 1&2) are in the closed position (Fig 23).
2. Take the footplate (Fig 24) and insert the two tapered spigots (Fig 24, Items 1&2) into the two sockets either side of the footplate height adjustment frame (Fig 21, Items 3&4). Push the footplate into the tubes until the plungers latch with an audible click.
3. Ensure the plungers are latched by moving the footplate in and out slightly.

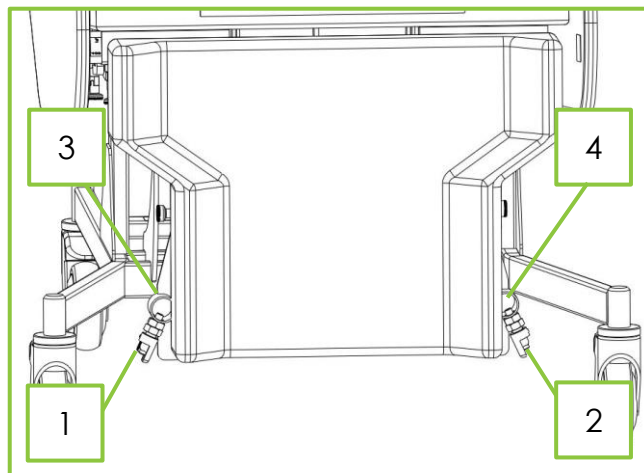

Figure 21

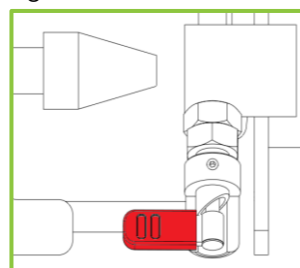

Figure 22 – Plunger Open

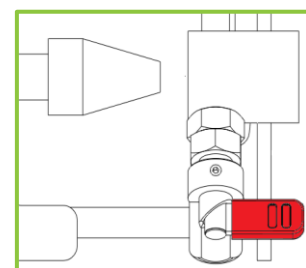

Figure 23 – Plunger Closed

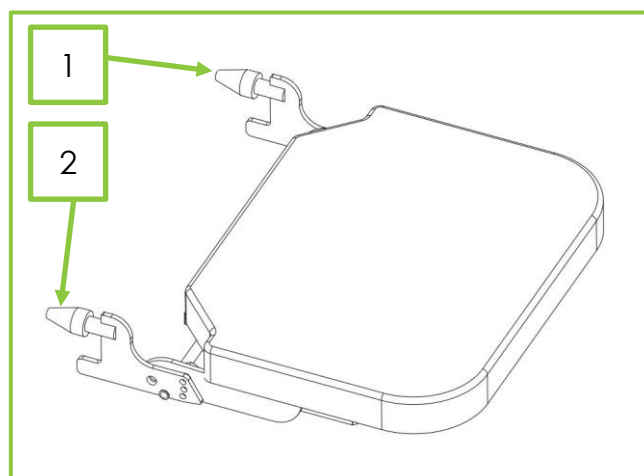

Figure 24

Operation - Removing the Footplate

1. Locate the plungers that secure the footplate either side of the leg rest, at the bottom of the footplate height adjustment frame (Fig 21, Items 1&2).
2. Turn the levers on the two plungers towards the front of the chair until they latch. The lever arm plungers are now locked in the open position. (Fig 22).
3. Pull the footplate out.

Adjustments – Changing the Footplate Angle

1. Locate the footplate angle adjustment plunger underneath the footplate (Fig 25, Item 1).

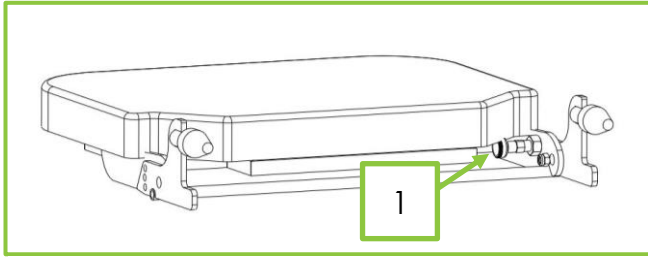

Figure 25

2. Pull and hold the cap of the plunger whilst moving the footplate to the desired measurement. The measurement setting is shown on the scale (Fig 26, Item 1) by the indicator on the frame (Fig 26, Item 2). Setting 1 = 90°, Setting 2 = 105° and Setting 3 = 120° from the vertical.

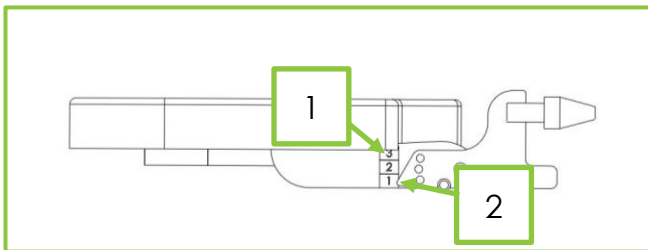

Figure 26

9. Controls

WARNING

Check for obstructions around, above and below the chair frame and position the chair so that it can operate through the full adjustment range without any possibility of obstruction or entrapment.

Always engage the castor brakes when the chair is stationary or left unattended.

Make sure the castor brakes are in the locked position before using the manual controls.

Be aware of entrapment risks through opening and closing gaps as the chair is adjusted.

Ensure the patient is in a stable sitting position while any of the following adjustments are made.

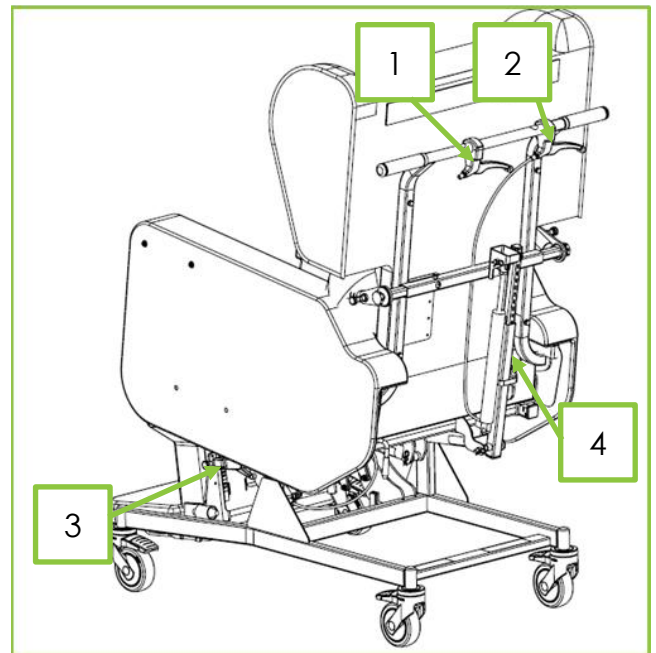

Figure 27 – Overview of controls

The Configura Advance chair has the following controls:

1. **Backrest** – The backrest can be adjusted between 90 degrees and 130 degrees from the seat angle; see page 5 for a diagram of this. The backrest lever (Fig 27, Item 1) is used to adjust this angle. The backrest is also fitted with a lockout slide (Fig 27, Item 4.) that can be used to restrict the use of the backrest angle adjustment.
1. **Tilt-in-Space** – The tilt-in-space position can adjust the seat angle from 7 degrees to 37 degrees from the horizontal position; see page 5 for a diagram of this. The Tilt-in- space lever (Fig 27, Item 2) is used to adjust this angle.

- Forward Tilt** – The chair can tilt forwards from 7 degrees normal tilt to 10 degrees of forward tilt with lock bolts removal.
- Legrest** – The legrest can be adjusted between 75 degrees and 160 degrees; see page 5 for a diagram of this. The Legrest lever (Fig 27, Item 3) can be used to adjust this angle.

Backrest Adjustment

- Make sure the brakes on all 3 locking castors are locked on.
- Locate the locking lever (Fig 28, Item 2) on the side of the backrest lockout slide (Fig 28, Item 1).
- Release the backrest lockout slide by lifting the locking lever away from the backrest lockout slide. The backrest can now be adjusted using the backrest lever.
- Pull the locking catch on the backrest lever, then pull the main lever (Fig 27, Item 1). Move the backrest to the desired measurement. The backrest angle measurement can be read off the scale at the top of the backrest adjustment slide (Fig 28, Item 3).

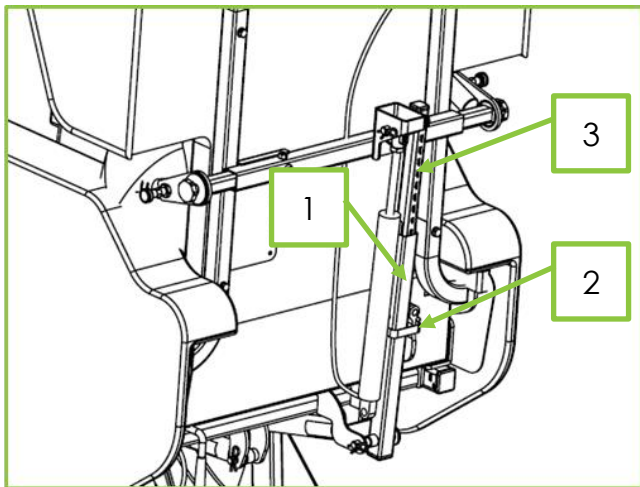

Figure 28

- Release the backrest adjustment lever to secure the backrest at the desired angle.
- If locking out the backrest is required, return the locking lever to the locked position. If the locking lever is too loose or too tight it may be necessary to rotate the whole lever clockwise or anti-clockwise respectively to achieve the desired locking action.
- If locking out the backrest is not required there is a Velcro strap that can be used to hold the lever in the unlocked position – see Fig 29.



Figure 29

Tilt-in-Space Angle Adjustment

- Make sure the brakes on all 3 locking castors are locked on.
- Pull and hold the tilt-in-space lever (Fig 27, Item 2) and move the chair to the desired tilt-in-space angle.
- Release the lever to lock the tilt-in-space angle.

Forward Tilt Adjustment

This function enables some patients to exit the chair more easily, however it must only be used following a risk assessment of the patient.

WARNING

Footplate must be removed before using the forward tilt function.

- The chair is delivered with this function locked. Remove the lock bolts on both LHS and RHS side on the chair using an Allen key. Ensure the correct bolts (Fig 30, Item 1) are removed.
- Retain the lock bolts in case they need refitting in the future.

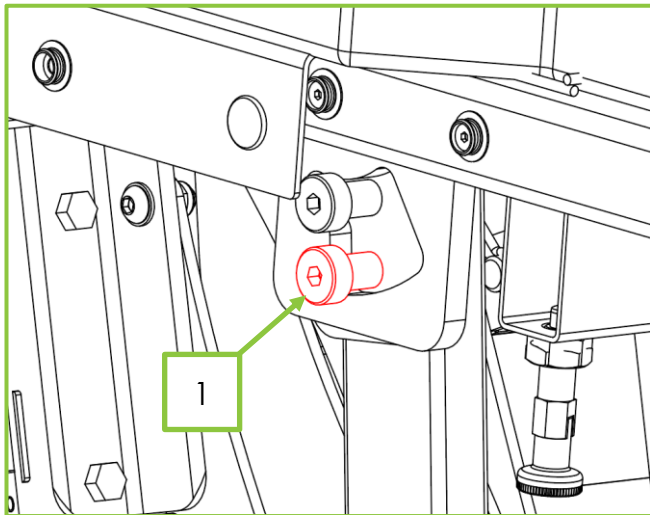

Figure 30

3. Remove the footplate (See section 8).
4. Make sure the brakes on all 3 locking castors are locked on.
5. Ensure it is safe to move the chair into the forward tilt position.
6. Pull and hold the tilt-in-space lever (Fig 27, Item 2) and move the chair forward to the forward tilt position.

Leg rest Adjustment

1. Make sure the brakes on all locking castors are locked on.
2. Locate the leg rest adjustment lever (Fig 27, Item 3).
3. Pull and hold the lever, then move the leg rest to the desired position.
4. Release the handle to secure the leg rest in position.

10. Using the castor brakes

The Configura Advance has the following castor system:

Front: One green pedal 125mm castor (directional lock) and one red pedal 125mm castor (normal brake).

Rear: Two linked pedal brake 150mm castors (pedal marked green and red to show which end to press).

Care must be taken to ensure the castor brakes are always locked when the chair is in use, being assembled or dismantled, so that the chair does not move accidentally.

Individually braked 125mm Castor Set

One green pedal 125mm castor (directional lock) and one red pedal 125mm castor (normal brake).

1. To lock the castor brake, press on the outer edge of the red lever. The lever will flip up.
2. To unlock the castor brake, press on the top of the red lever to bring it back horizontal.



Brake on



Brake off

The green castor has a directional locking function that assists with pushing the chair in straight/forward direction.

1. Push the chair forward so the castor is running in the direction of travel.
2. To lock the castor swivel, press on the outer edge of the green lever. The lever will flip up.
3. Push the chair forward, moving slightly from side to side, to ensure
4. To unlock the castor swivel, press on the top of the green lever to bring it back horizontal.



Directional lock on



Directional lock off

Centrally Braked 150mm Castor Set

Two linked pedal brake 150mm castors (pedal marked green and red to show which end to press).

The two rear 150mm castors of the chair can be braked at the same time using the foot lever.

1. To lock the central brake, press the rear red part of the foot lever down until the brake locks. Figure 31 shows the brake locked.
2. To unlock the brake, press the front green part of the foot lever down until the brake disengages. Figure 32 shows the brake unlocked.

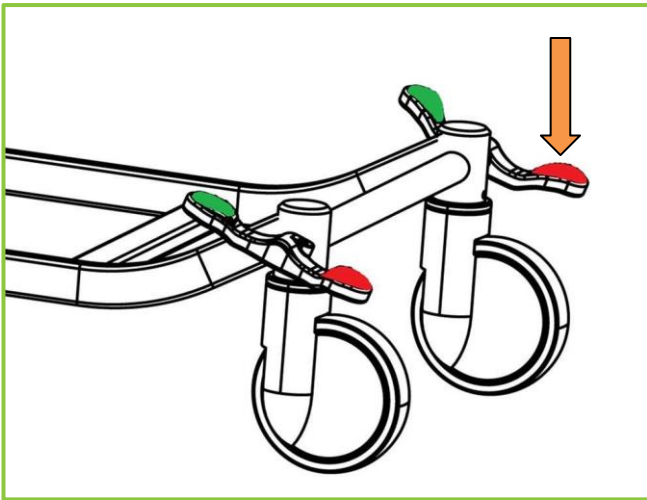

Figure 31 – Brake locked

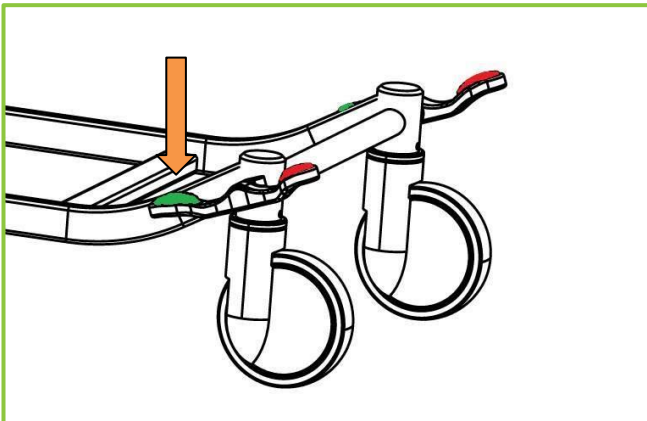

Figure 32 – Brake unlocked

11. Functionality check

WARNING

Functionality check **MUST** be carried out by suitably trained and qualified personnel.

Check for obstructions around, above and below the chair frame and position the chair so that it can operate through the full adjustment range without any chance of obstruction or entrapment.

Always engage the castor brakes when the chair is stationary or left unattended.

These checks must be carried out after chair assembly, adjustment or maintenance.

Checklist

1. Check overlay poppers are engaged (Fig 7, Item1)
2. Tilt the chair backwards
3. Tilt the chair forward to upright position
4. Raise the leg rest
5. Lower the leg rest
6. Lower the backrest
7. Raise the backrest
8. Check the correct function of the castors.
9. Ensure footrest is fitted correctly.
10. Ensure sidepieces are fitted correctly.

12. Cleaning & disinfection

WARNING

The chair must be disconnected from the power supply when being cleaned or disinfected.

All functions **MUST** be tested and approved by a competent person after cleaning or disinfection.

The chair **MUST** be cleaned and disinfected before re-using the chair for a different patient.

Cleaning Information:

To disinfect the chair, only use detergents designed for use in healthcare e.g. warm soapy water. Do not use abrasives, scourers or other materials that could damage the coating. Do not use corrosives, caustics or strong acids.

Do not use detergents that could alter the structure or behaviour of the plastics (petrol etc.).

Clean by wiping with a damp cloth. Alternatively use Microfibre cleaning cloth without any soap.

For extreme soiling use a 5% Sodium Hypochlorite solution.

The chair is not designed for maintenance in automatic chair washers or for cleaning with pressurised water, spraying, showering or steam cleaning.

Accora cannot be liable for any damage or risk of damage if inappropriate cleaning or disinfectant agents are used.

Cleaning procedure:

1. Move the chair to where cleaning will take place and lock the chair castors.
2. Remove the cushions and any accessories such as profiled headrest, external laterals.
3. Clean as described in the "Cleaning Information".

13. Troubleshooting

WARNING

Troubleshooting **MUST** be carried out by suitably trained and qualified personnel.

Do not attempt to open any electrical part enclosures.

All functions **MUST** be tested and approved by a competent person after troubleshooting.

Problem	Possible solution(s)
Backrest will not recline (manual version).	Ensure the backrest lockout slide is released – see section 10 of this manual.

If the Configura Advance chair still does not function correctly, please contact Accora for further advice.

14. Storage

For problem-free storage we recommend:

1. Remove the accessories
2. Wrap the chair and accessories or cover them so that the coating and plastic parts are not damaged
3. Chair should be stored in a temperature between -20°C to +50°C (-4°F to +122°F).
4. Chair should be stored in a relative humidity (non-condensing) between 30% and 75%

15. Daily inspection

Daily visual inspection is strongly recommended and may be carried out by carer, user or another person.

The following checks must be carried out:

1. Does the chair operate as per its intended purpose without unexpected noise or motion?
2. Are there any signs of abuse or excessive wear?
3. Is any fabric torn or damaged? Pay particular attention to the seat overlay.
4. Check that the overlay is secured to the frame with the press studs.
5. Are all fixtures and fittings tight and secure?
6. Does the chair frame appear stable and secure?
7. Are all accessories fitted in line with the accessory manufacturer or accessory supplier's instructions?
8. Are all the castor brakes in the locked position?
9. Are all electrical cables for accessories, (e.g. air pump) secured and routed to prevent damage?
10. Is the area around, above and below chair clear of possible obstruction?
11. Is the footplate securely attached?
12. Are the plungers securing the sidepieces locked and secure?
13. Is there any risk of entrapment or patient injury?
14. Are any accessory electrical cables pinched, crushed or damaged in any way?

If any damage, performance issue or cause for concern is noted during this inspection the chair should be withdrawn from service and appropriate steps should be taken.

16. General maintenance

WARNING

Maintenance **MUST** be carried out by suitably trained and qualified personnel.

All functions **MUST** be tested and approved after maintenance by suitably trained and qualified personnel.

Do not carry out maintenance with service user or patient on the chair.

Repairs to the Configura Advance chair must be carried by suitably trained and qualified personnel.

After any maintenance has taken place a functionality check must be carried out (see section 11).















17. Guarantee

Model	Configura Advance chair
Warranty period	2 years

18. Disposal

In the event of the disposal of materials from the chair, end-of-life parts must be disposed of in accordance with current environmental regulations

19. Table of symbols

	Warning, beware of potential hazard – refer to instruction for use
	Refer to instructions for use
	Complies with the European Medical Device Regulation 2017/745
	Model number
	Serial number
	Manufactured date
	Manufacturer
	Unique Device Identification (UDI) label
	The B symbol indicates this product has a degree of protection against electric shock for type B equipment
IPX4	Degree of protection against liquid ingress
	Do not dispose of in household waste
	Degree of protection against electric shock: Class II Double Insulated
	For indoor use only
	Medical Device in accordance with EU Medical Device Regulation 2017/745.
	EC Representative

20. Contact details

	UK and Rest of World	USA
Address	Accora Ltd. Charter House, Barrington Road Orwell, Cambridge SG8 5QP, UK	Accora Inc. 9210 Corporate Blvd. Suite 120 Rockville, MD 20850 USA
Telephone	+44 (0)1223 206100	+1 301-560-2400
Email	info@accora.care	information@accora.care
Website	www.accora.care	www.accora.care

This page intentionally left blank

Accora



Accora
Barrington Road
Orwell
Cambridge
SG8 5QP
United Kingdom

T: +44 (0)1223 206100
info@accora.care
www.accora.care

IFU-SC3-001US REV 02