

Universal Procedures Table

Model Numbers:

230 -001 thru -004

630 -001 thru -009

75 -019 thru -021

Some Models NO LONGER IN PRODUCTION
Some service parts may not be available for this product!



Service and Parts Manual



630 shown

ISA15380

FOR USE BY MIDMARK TRAINED TECHNICIANS ONLY

Table Of Contents

General Information

GENERAL INFORMATION

Symbols	iii
Ordering Parts	iii
Model / Serial Number	
Location	iii
Weights, Dimensions,	
Electrical Specifications	iv
Model Identification /	
Compliance Charts:	
230 & 75 (-019)	v
630 & 75 (-020 / -021)	vi
Scheduled Maintenance	vii
Warranty Information	viii

Section A

OPERATION & TROUBLESHOOTING

Error Codes (Refer to page B-40)	
Power To The Table:	
Models w/ Standard Base	A-2
Models w/ Rotational Base	A-4
Base Up / Down	A-8
Back Up / Down	A-18
Tilt Up / Down	A-28
Foot Up / Down	A-38
Crash Avoidance System	A-48
Position Programming	A-52
"Home" Function	A-56
Quick Chair™ Function	A-62
Table Receptacles	A-66
Upholstery Heater System	A-68
Rotational Base	
Brake System	A-72

Section B

COMPONENT TESTING & REPAIR

Primary Fuses	B-2
Limit Switches	B-3
Hand / Foot Controls	B-6
Base Actuator	B-11
Back Actuator	B-17
Tilt Actuator	B-21
Foot Actuator	B-25
Gas Springs	B-28

Section B

COMPONENT

TESTING & REPAIR - continued

Isolation Transformer /	
Table Receptacles	B-29
Main System Transformer	B-30
Position Sensors	B-32
Main PC Board (Error Codes)	B-40
Upholstery Heater System	B-45
Headrest Mechanism	B-50
Rotational Base	
Brake System	B-51

Section C

ACCESS PROCEDURES

Removing & Installing:

PC Board Cover:	
Models w/ Standard Base	C-2
Models w/ Rotational Base	C-3
Base Shrouds:	
Raising (w/bungee cord)	C-4
Removing / Installing	C-5
Upholstery	C-6
Back Section Covers	C-7
Seat Section Covers	C-8
Foot Section Covers:	
Midmark Models	C-9
Ritter Models	C-10
Junction Board Cover	C-11

Section D

WIRING DIAGRAMS

230	D-"
630	D-"
75	D-"

Section E

EXPLODED VIEWS / PARTS LISTS

230	E-2
630	E-3
75:	
(-019)	E-2
(-020 / -021)	E-3

* Indicates multiple pages due to a serial number break for the parts illustration

Symbols



WARNING

Indicates a potentially hazardous situation which could result in serious injury if not avoided.



Caution

Indicates a potentially hazardous situation which could result in injury if not avoided.



Equipment Alert

Indicates a potentially hazardous situation which could result in equipment damage if not avoided.

Note

Amplifies a procedure, practice, or condition.



In Section A, test the components in the order indicated. (ex. **1st** ✓ then, **2nd** ✓)

Refer to Section B for component testing procedures.

These symbols are used throughout this manual to represent the operational status of table functions and components.



Indicates the function / component is working properly. No action required.



Indicates the function / component is working, but a problem exists.



Indicates the function / component is not working at all.

Ordering Parts

The following information is required when ordering parts:

- Serial number & model number
- Part number for desired part.

[Refer to Exploded Views / Parts Lists section]

Non-warranty parts orders may be faxed to Midmark using the Fax Order Form in the back of this manual.

For warranty parts orders, call Midmark's Technical Service Department with the required information.

Hours: 8:00 am until 5:00 pm EST [Monday - Friday]

Phone: 1-(800)-Midmark

Model / Serial Number Location

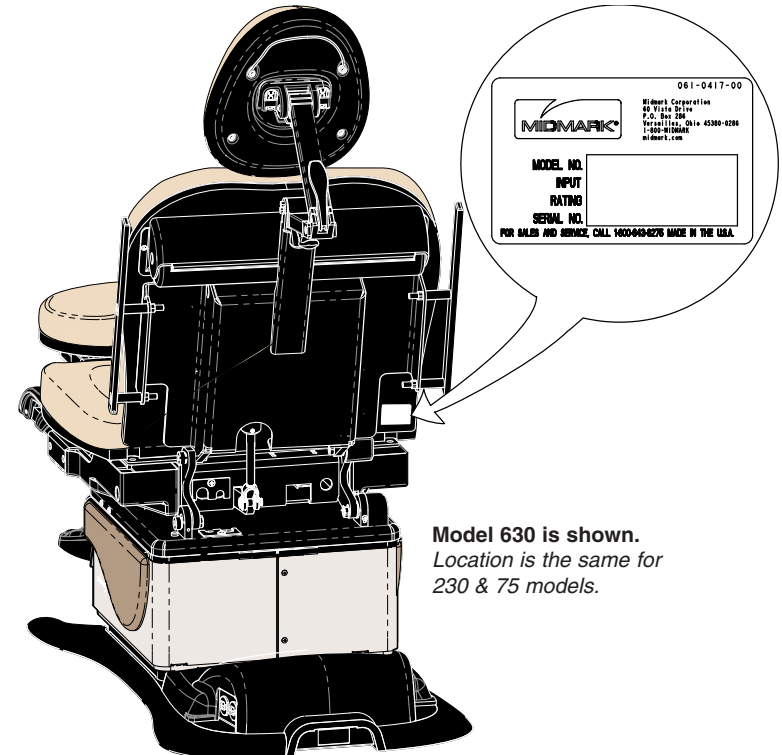

Model 630 is shown.
Location is the same for 230 & 75 models.

General Information

Weights, Dimensions, Electrical Specifications

Patient Weight (Maximum)	450 lbs (204.1 kgs)
Paper Roll (maximum size):	18 in. long x 3.5 in. diameter (45.7 x 8.9 cm)
Range of Motion & Dimensions	[See illustration]
Weight of Table:	
230 / 630 / 75 (w/standard base)	455 lbs (206.4 kg)
w/packaging & skid	510 lbs (231.3 kg)
230 / 630 / 75 (w/rotational base)	540 lbs (244.9 kg)
w/packaging & skid	600 lbs (271.1 kg)
Power Cord:	8 ft. (243.8 cm) long
Electrical Requirements:	[See Compliance Charts]
Foot / Hand Control Voltage:	10 VAC, SELV (Safety Extra Low Voltage)
Duplex Receptacle (optional)	
maximum load:	115 VAC, 3A, 50/60 Hz
Fuses:	
<u>Main Power (located at power cord inlet):</u>	
F1 & F2	6.3A, 250V, Type-T, 5 x 20 mm High-Breaking Current
<u>Upholstery Heater (located on uph. heater PC board):</u>	
F1 & F2	1/2 A, 250V, Type-T, 1-1/4" x 1/4"
Duty Cycle (motor run time):	Intermittent Operation [30 seconds ON / 5 minutes off]
Classifications:	Class 1, Type B Applied Part
Protection against ingress of fluids:	
Foot Control only:	Ordinary Equipment IPX1
Regulatory Compliance:	[See Compliance Charts]
Table Speeds (by function):	
Base / Back / Tilt (all models)	15 - 25 seconds
Foot (630)	less than 15 seconds
Foot (230)	less than 20 seconds

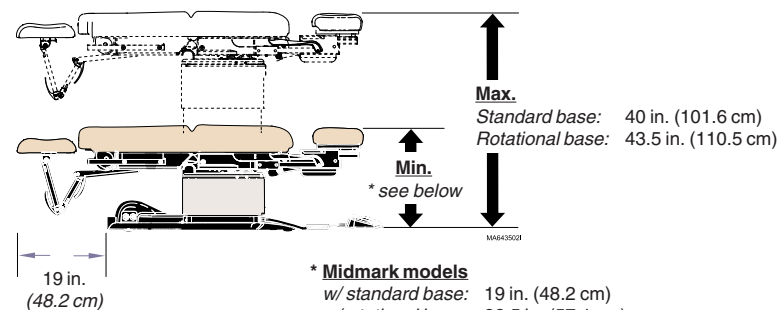

*** Midmark models**
w/ standard base: 19 in. (48.2 cm)
w/rotational base: 22.5 in. (57.1 cm)

Ritter models
w/standard base: 22.5 in. (57 cm)
w/rotational base: 26 in. (66 cm)

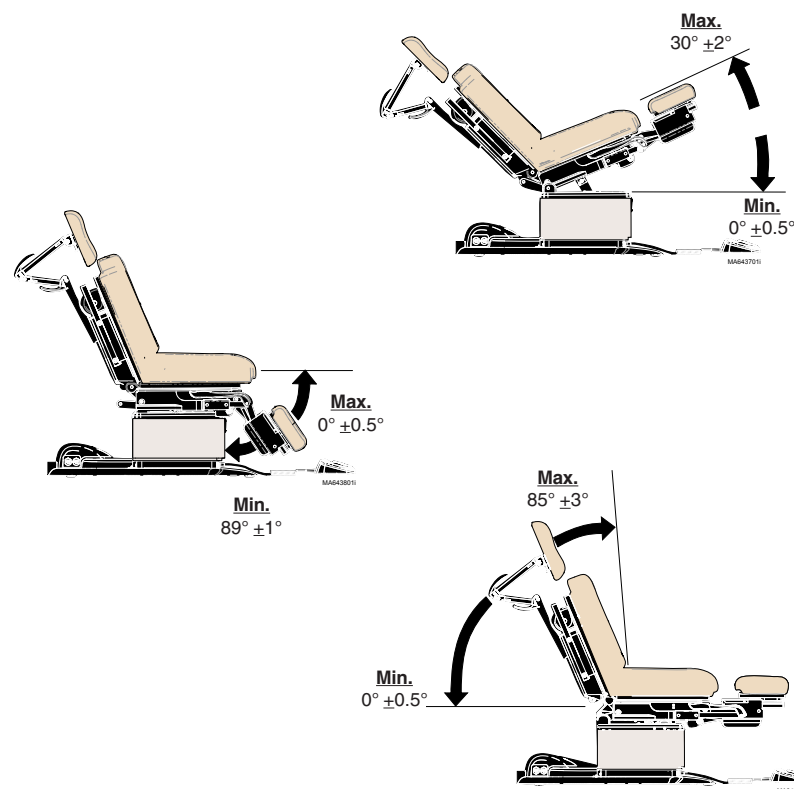

General Information

Model Identification / Compliance Chart - 230 & 75 (-019)

Fire Code Ratings

All standard upholstery sets comply with: California Bureau of Home Furnishing [Technical Bulletin 117](#)

Optional upholstery sets are available that comply with: California Bureau of Home Furnishing [Technical Bulletin 133](#).

Model	Description	Serial Number Prefix	Complies To:				Electrical Ratings:		
			UL 60601-1	CAN/CSA 22.2, #601.1-M90	IEC 60601-1	EN 60601-1-2 (EMC)	VAC +/-10%	Amps	Cycles (Hz)
230-001	Ritter Universal Proc. Table <i>(Non-Programmable)</i>	V	X	X	X	X	Configurable		50 / 60
							115 230	7 3.5	
230-002	Ritter Universal Proc. Table <i>(Non-Programmable)</i> <i>w/ Receptacle</i>	V	X	X	X	X	115	10	50 / 60
230-003	Ritter Universal Proc. Table <i>(Non-Programmable)</i> <i>w/ rotational base</i>	V	X	X	X	X	Configurable		50 / 60
							115 230	7.5 3.8	
75-019 (230-004)	Ritter Universal Proc. Table <i>(Non-Programmable)</i>	V	X	X	X	X	Configurable		50 / 60
							115 230	7 3.5	

General Information

Model Identification / Compliance Chart - 630 & 75 (-020 / -021)

Fire Code Ratings

All standard upholstery sets comply with: California Bureau of Home Furnishing [Technical Bulletin 117](#)

Optional upholstery sets are available that comply with: California Bureau of Home Furnishing [Technical Bulletin 133](#).

Model	Description	Serial Number Prefix	Complies To:				Electrical Ratings:		
			UL 60601-1	CAN/CSA 22.2, #601.1-M90	IEC 60601-1	EN 60601-1-2 (EMC)	VAC +/-10%	Amps	Cycles (Hz)
630-001	Midmark Universal Proc. Table (Non-Programmable)	V	X	X	X	X	Configurable		50 / 60
							115 230	7 3.5	
630-002	Midmark Universal Proc. Table (Programmable)	V	X	X	X	X	Configurable		50 / 60
							115 230	7 3.5	
630-003	Midmark Universal Proc. Table (Non-Programmable) w/ Receptacle	V	X	X	X	X	115	10	50 / 60
630-004	Midmark Universal Proc. Table (Programmable) w/ Receptacle	V	X	X	X	X	115	10	50 / 60
630-005	Midmark Universal Proc. Table (Non-Programmable) w/ Rotational Base	V	X	X	X	X	Configurable		50 / 60
							115 230	7.5 3.8	
630-006	Midmark Universal Proc. Table (Prog.) w/ Rotational Base	V	X	X	X	X	Configurable		50 / 60
							115 230	7.5 3.8	
630-007	Midmark Universal Proc. Table (Programmable) w/ Heated Upholstery	V	X	X	X	X	115	7	50 / 60
75-020 (630-008)	Midmark Universal Proc. Table (Non-Programmable) w/ Receptacle	V	X	X	X	X	115	10	50 / 60
75-021 (630-009)	Midmark Universal Proc. Table (Programmable) w/ Receptacle , no foot control	V	X	X	X	X	115	10	50 / 60

Scheduled Maintenance Universal Procedures Table				
Interval	Inspection or Service	Service, Adjust, Repair and / or Replace as Required <small>(Refer to appropriate S&P or Quick Reference Guide)</small>	230	630
Weekly	Cleaning	Clean upholstery with diluted bleach solution 10:1 (water:bleach)	X	X
		Wipe painted metal & plastic surfaces with a clean soft cloth and mild cleaner. (NOTE: Periodic application of common furniture wax will ease cleaning, and maintain the luster of the surfaces).	X	X
	Obvious Damage	Visually inspect components for damage that could cause problems during operation or unsafe operation.	X	X
Semi-Annually	Mechanical Operation	Check all mechanical functions using the foot control. Repeat using the hand control when present.	X	X
		Table shrouds should move smoothly & quietly when base is raised & lowered. (NOTE: There are plastic glides on the shroud tabs. Missing glides may result in noisy operation.)	X	X
	Labels / Decals	Replace any missing or illegible labels.	X	X
	Hardware	All fasteners must be present and fastened securely.	X	X
	Electrical System	Inspect power cord and all wiring for damage.	X	X
Be sure all electrical connections are tight.		X	X	
Date of Service: ____/____/____			Model:	
Location: Service Technician:			Serial Number:	

General Information

Warranty Information

SCOPE OF WARRANTY

Midmark Corporation (“Midmark”) warrants to the original purchaser its new Alternate Care products and components (except for components not warranted under “Exclusions”) manufactured by Midmark to be free from defects in material and workmanship under normal use and service. Midmark’s obligation under this warranty is limited to the repair or replacement, at Midmark’s option, of the parts or the products the defects of which are reported to Midmark within the applicable warranty period and which, upon examination by Midmark, prove to be defective.

APPLICABLE WARRANTY PERIOD

The applicable warranty period, measured from the date of delivery to the original user, shall be one (1) year for all warranted products and components.

EXCLUSIONS

This warranty does not cover and Midmark shall not be liable for the following: (1) repairs and replacements because of misuse, abuse, negligence, alteration, accident, freight damage, or tampering; (2) products which are not installed, used, and properly cleaned as required in the Midmark “Installation” and or “Installation / Operation Manual for this applicable product. (3) products considered to be of a consumable nature; (4) accessories or parts not manufactured by Midmark; (5) charges by anyone for adjustments, repairs, replacement parts, installation, or other work performed upon or in connection with such products which is not expressly authorized in writing in advance by Midmark.

EXCLUSIVE REMEDY

Midmark’s only obligation under this warranty is the repair or replacement of defective parts. Midmark shall not be liable for any direct, special, indirect, incidental, exemplary, or consequential damages or delay, including, but not limited to, damages for loss of profits or loss of use.

NO AUTHORIZATION

No person or firm is authorized to create for Midmark any other obligation or liability in connection with the products.

THIS WARRANTY IS MIDMARK’S ONLY WARRANTY AND IS IN LIEU OF ALL OTHER WARRANTIES, EXPRESS OR IMPLIED. MIDMARK MAKES NO IMPLIED WARRANTIES OF ANY KIND INCLUDING ANY WARRANTIES OF MERCHANTABILITY OR FITNESS FOR ANY PARTICULAR PURPOSE. THIS WARRANTY IS LIMITED TO THE REPAIR OR REPLACEMENT OF DEFECTIVE PARTS.

Additional Information

Failure to follow the guidelines listed below will void the warranty and/or render the table unsafe for use.

- If a malfunction is detected, do not use the table until necessary repairs are made.
- Do not attempt to disassemble table, replace components, or perform adjustments unless you are a Midmark authorized service technician.
- Do not use another manufacturer's parts to replace malfunctioning components. Use only Midmark replacement parts

SF-1487 REV. A1

Section A

Operation & Troubleshooting



<u>Function / System</u>	<u>Page</u>
Power To The Table:	
<i>models w/Standard Base</i>	A-2
<i>models w/Rotational Base</i>	A-4
Base Up / Down	A-8
Back Up / Down	A-18
Tilt Up/Down	A-28
Foot Up/Down	A-38
Crash Avoidance System	A-48
Position Programming	A-52
"Home" Function	A-56
Quick Chair Function	A-62
Table Receptacles	A-66
Upholstery Heater System	A-68
Rotational Base Brake System	A-72

Operation & Troubleshooting

Power To The Table (models w/ Standard Base)

This illustration shows only the components that affect ALL TABLE FUNCTIONS.
Refer to the following page for a detailed description of the power supply to the table.

Troubleshooting
[No Power / No Functions Will Operate]

Power Light is:	Page
OFF	A-6
ON	A-7

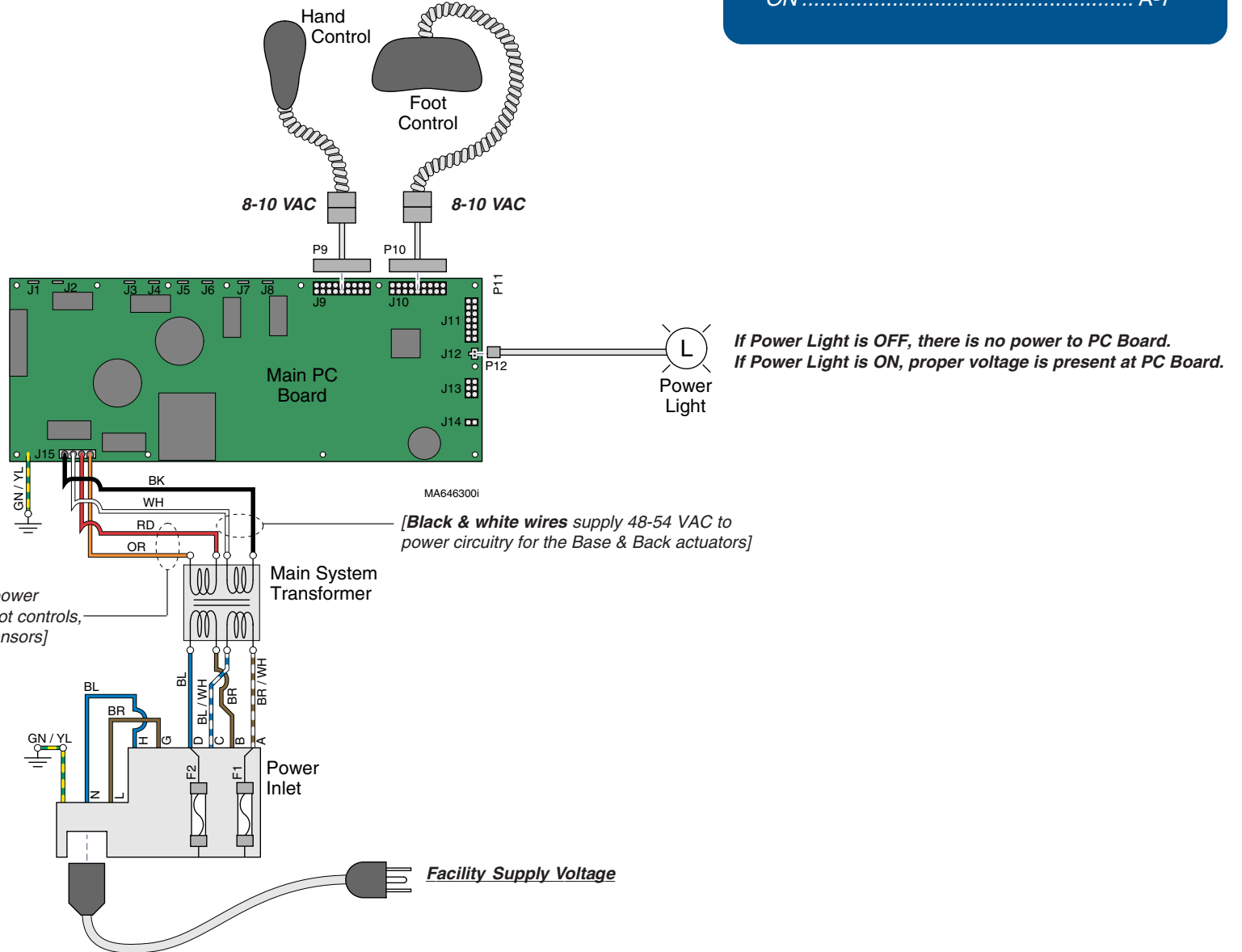

Operation & Troubleshooting

Power To The Table (models w/ Standard Base)

Facility Supply Voltage

With the table's power cord properly connected, facility supply voltage (115 or 230 VAC) is supplied thru the cord to the power inlet.

Power Inlet



EQUIPMENT ALERT

The voltage setting displayed in the power inlet window must match facility supply voltage (115 or 230 VAC).

[Remove fuse holder and rotate 180° to change voltage setting].

Current flows thru two fuses in the power inlet, to the main system transformer.

Main System Transformer

NOTE

This transformer is protected from overload by a thermal cutout feature. This will automatically reset when the transformer cools.

Line voltage (115 or 230 VAC) is supplied to the main system transformer. The transformer reduces the voltage and current flows to the main PC board thru two separate windings (four wires).

[The black & white wires supply 48-54 VAC to power circuitry for the Base & Back actuators only].

[The red & orange wires supply 34-37 VAC to power circuitry for the Tilt & Foot actuators, hand/foot controls, power light, all limit switches, and position sensors (on Midmark models only)].

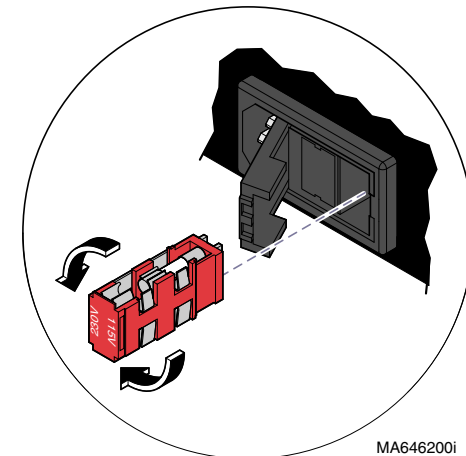
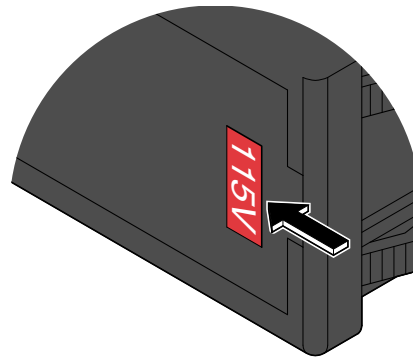

MA646200i

Power Indicator Light

When voltage is applied to the PC board, the power light is illuminated.

Main PC Board

Circuitry on the PC board provides the required voltage to power all of the table's components: *hand/foot controls, actuators, limit switches, and position sensors.*

Hand / Foot Controls

Circuitry on the main PC board supplies 8-10 VAC to the hand / foot control connection ports.

Models: | 230 (-001/-002/-004) | 630 (-001 thru -004) & (-007 thru -009) | 75 (-019 thru -021)
Serial Numbers: | all | all | all

Power To The Table
(Standard Base)

© Midmark Corporation 2005 SF-1838

Rev. 7/5/12

Operation & Troubleshooting

Power To The Table (models w/ Rotational Base)

This illustration shows only the components that affect ALL TABLE FUNCTIONS.
Refer to the following page for a detailed description of the power supply to the table.

Troubleshooting
[No Power / No Functions Will Operate]

Power Light is:	Page
OFF	A-6
ON	A-7

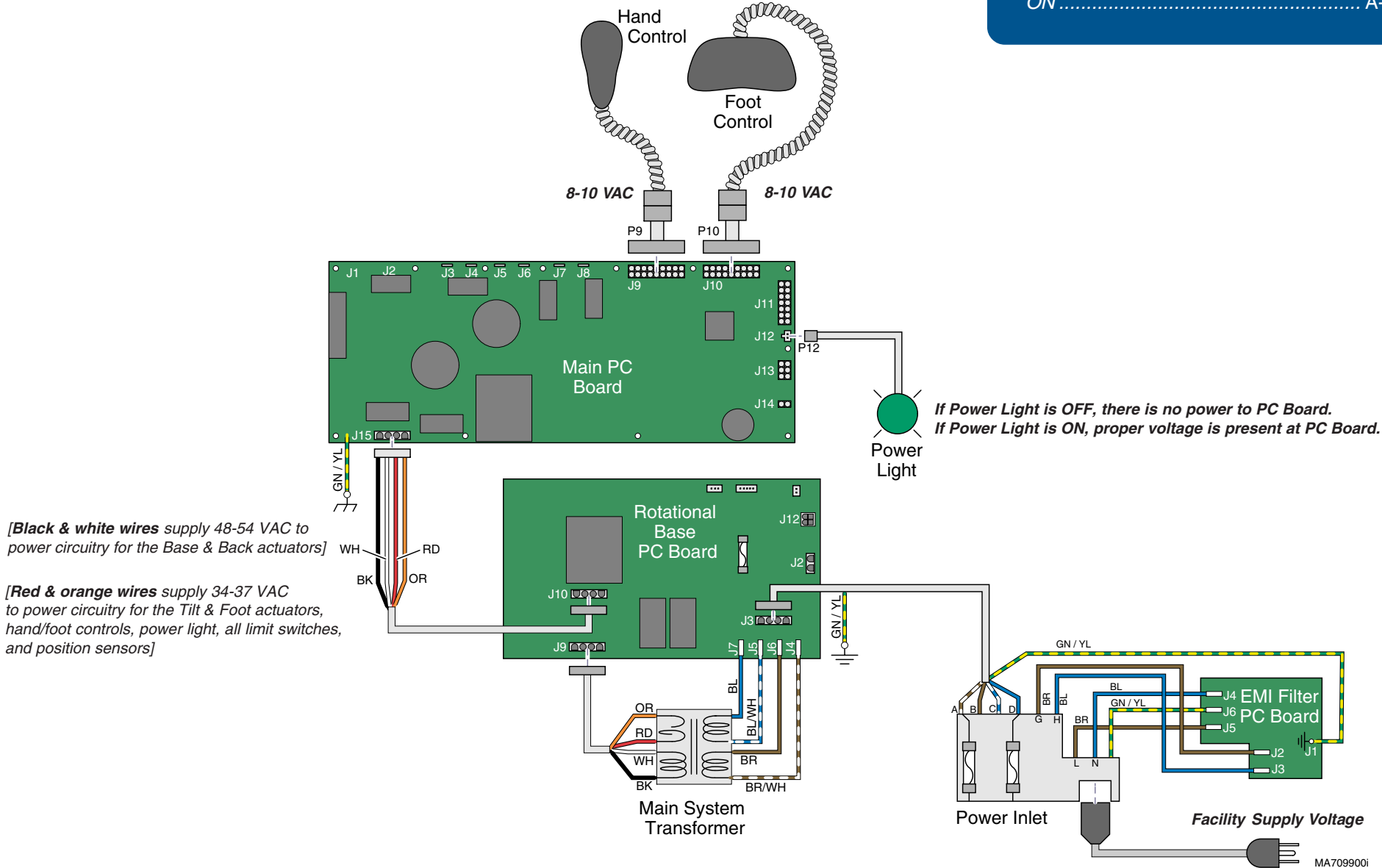

[Black & white wires supply 48-54 VAC to power circuitry for the Base & Back actuators]

[Red & orange wires supply 34-37 VAC to power circuitry for the Tilt & Foot actuators, hand/foot controls, power light, all limit switches, and position sensors]

Power To The Table
(Rotational Base)

Models:	230 (-003)	630 (-005 & -006)
Serial Numbers:	all	all

Operation & Troubleshooting

Power To The Table (models w/ Rotational Base)

Facility Supply Voltage

With the table's power cord properly connected, facility supply voltage (115 or 230 VAC) is supplied thru the cord to the power inlet.

Power Inlet / EMI Filter Board



EQUIPMENT ALERT

The voltage setting displayed in the power inlet window must match facility supply voltage (115 or 230 VAC).

[Remove fuse holder and rotate 180° to change voltage setting].

Current flows from the power inlet thru the EMI filter board, then back thru the power inlet fuses to the rotational base PC board.

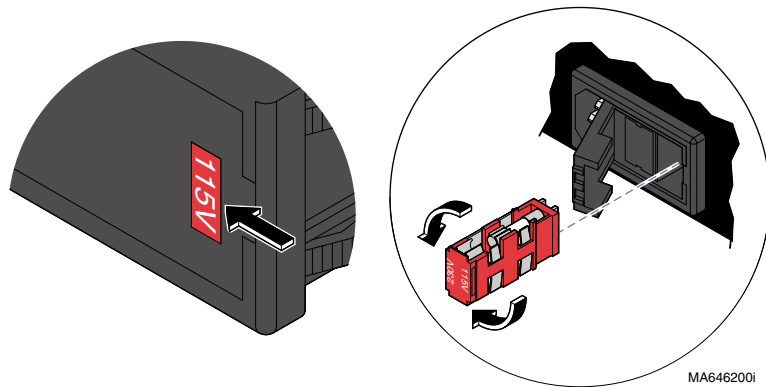

Rotational Base PC Board

Current flows thru the rotational base PC board to the main system transformer. The transformer reduces the voltage and current flows back to the rotational base PC board.

Circuitry on the rotational base PC board provides the required voltage to power the rotational base brake system.

The reduced voltage is supplied to the main PC board thru the rotational base PC board.

Main System Transformer

NOTE

This transformer is protected from overload by a thermal cutout feature. This will automatically reset when the transformer cools.

Line voltage (115 or 230 VAC) is supplied to the main system transformer thru the rotational base PC board. The transformer reduces the voltage and current flows back to the rotational base PC board, then to the main PC board thru two separate windings (four wires).

[The black & white wires supply 48-54 VAC to power circuitry for the Base & Back actuators only].

[The red & orange wires supply 34-37 VAC to power circuitry for the Tilt & Foot actuators, hand/foot controls, power light, all limit switches, and position sensors (on Midmark models only)].

Power Indicator Light

When voltage is applied to the PC board, the power light is illuminated.

Main PC Board

Circuitry on the PC board provides the required voltage to power all of the table's components: hand/foot controls, actuators, limit switches, and position sensors.

Hand / Foot Controls

Circuitry on the main PC board supplies 8-10 VAC to the hand / foot control connection ports.

Models: | 230 (-003) | 630 (-005 & -006)
Serial Numbers: | all | all

Power To The Table
(Rotational Base)

Operation & Troubleshooting

Power to the Table - continued

Problem: No functions will operate - and Power light is **OFF**.

Refer To:	Page
Primary Fuses	B-2
Main System Transformer	B-30
Main PC Board	B-40
Wiring Diagrams	D-1
Exploded Views / Part Numbers	E-1

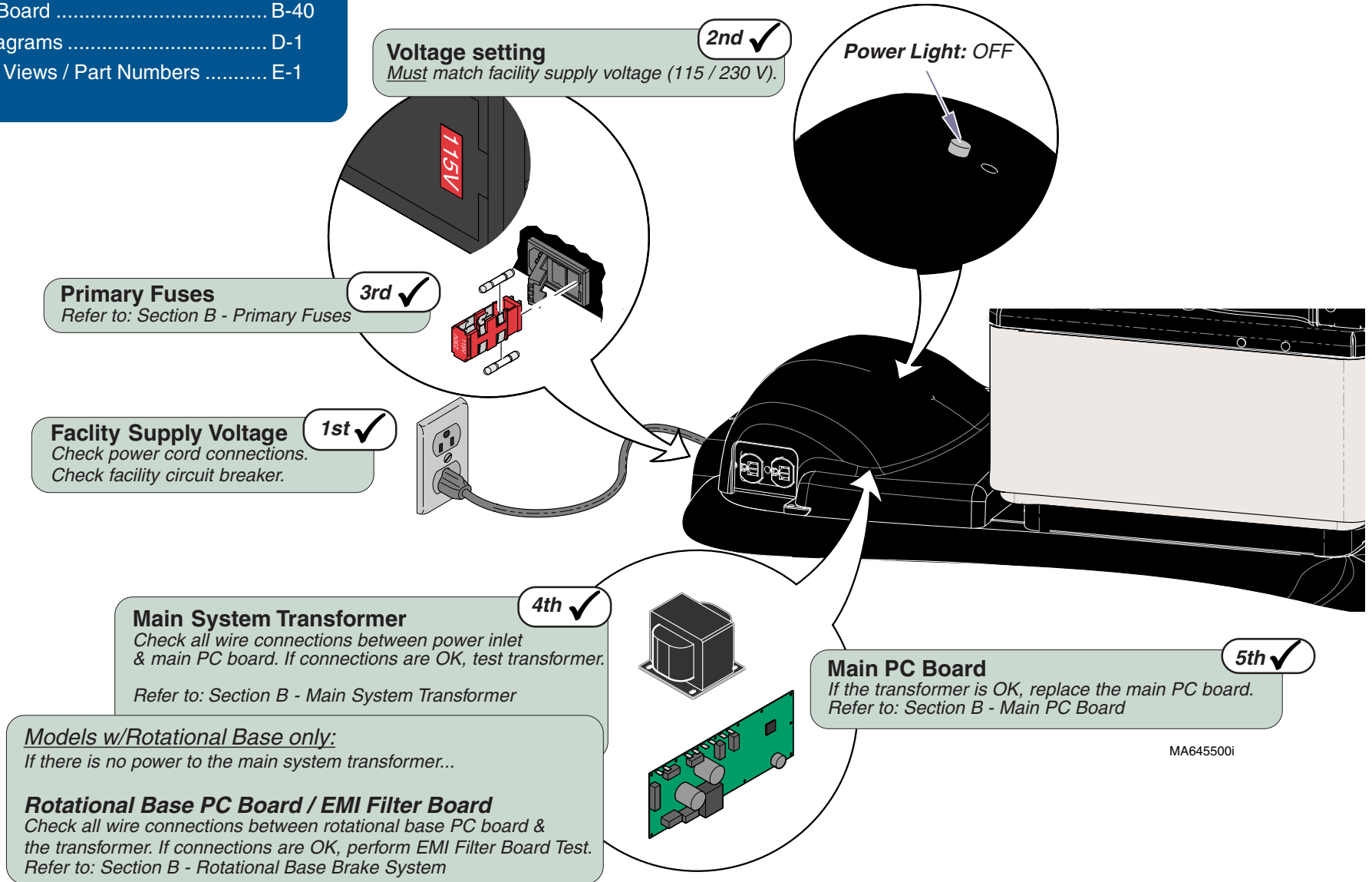

MA645500i

Operation & Troubleshooting

Power to the Table - continued

Problem: No functions will operate - and Power light is **ON**.

Refer To:	Page
Hand & Foot Controls	B-6
Main PC Board	B-40
Wiring Diagrams	D-1
Exploded Views / Part Numbers	E-1

Power Light: ON

Loose / Damaged Wire Connections
(between connection ports & PC board)

3rd ✓

Hand / Foot Controls

Check cords for damage / proper connection.
Check both connection ports on table.

Refer to: Section B - Hand & Foot Controls

1st ✓

Position "4" Button



MA645401i

Programmable Models only:
Press "4" button on hand / foot control for five seconds, then try functions again...
If table functions operate, go to Section B, Main PC Board (Hand/Foot Control Lockout Feature)
If table functions still will not move, go to next check.

2nd ✓

Check for error code(s)

Refer to: Section B - Main PC Board

6th ✓

Models:
Serial Numbers:

ALL

Power To The Table

Operation & Troubleshooting

Base UP / DOWN Function

This illustration shows only the components that affect the Base UP / DOWN function. Refer to the following page for a detailed description of Base UP / DOWN operation.

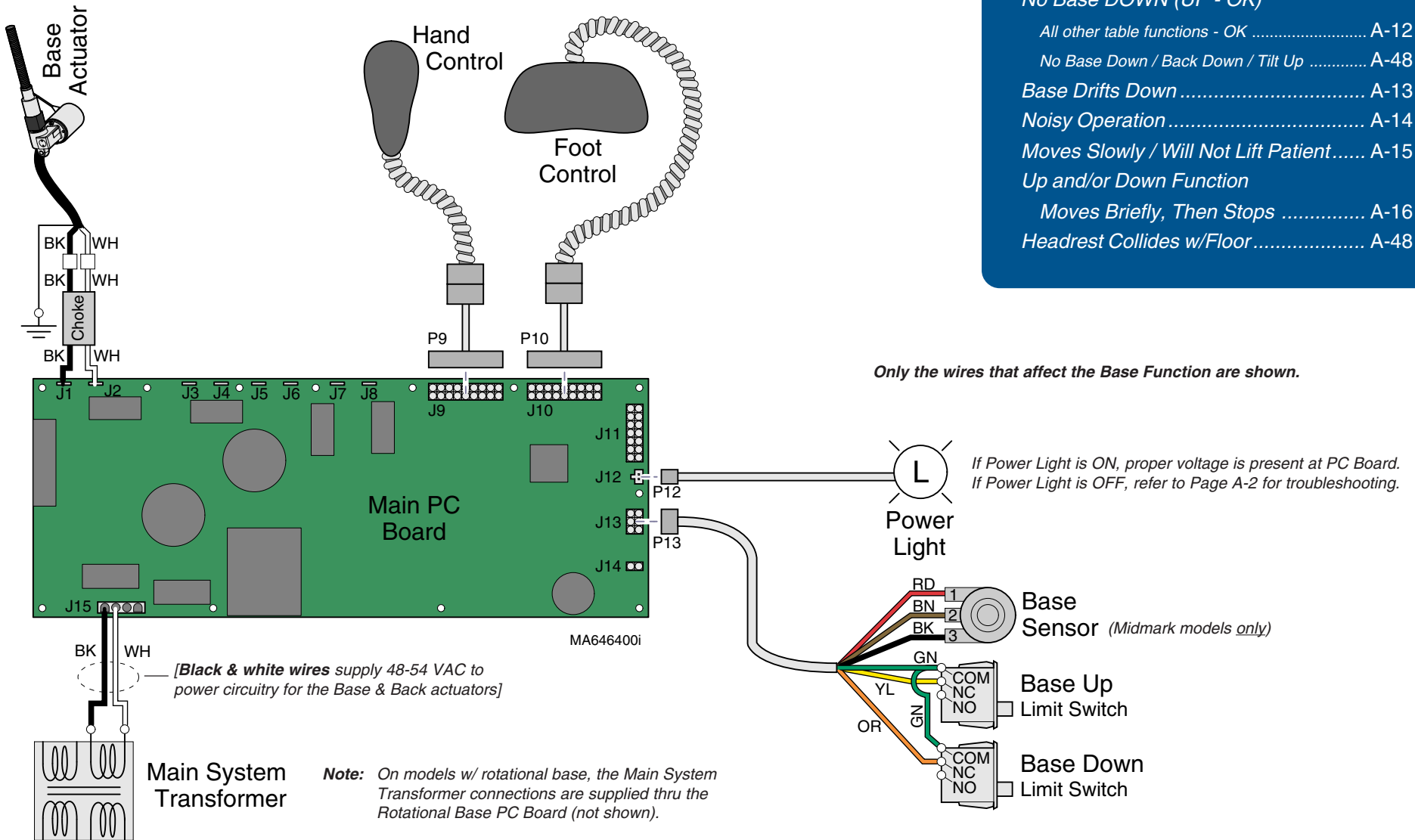

Troubleshooting

[Base Up / Down Function]

Problem	Page
No Base UP or DOWN	A-10
No Base UP (DOWN - OK)	A-11
No Base DOWN (UP - OK)	A-12
All other table functions - OK	A-12
No Base Down / Back Down / Tilt Up	A-48
Base Drifts Down	A-13
Noisy Operation	A-14
Moves Slowly / Will Not Lift Patient	A-15
Up and/or Down Function	
Moves Briefly, Then Stops	A-16
Headrest Collides w/Floor	A-48

Base UP / DOWN Function

Is There Power To The Table?

When voltage is present at the PC board, the power light is illuminated.

[Refer to 'Power To The Table' (page A-2), for description of current flow to the PC board].

Power To Foot / Hand Controls

Circuitry on the PC board supplies 8-10 VAC to the hand / foot control connection ports.

Base Up Operation

When the Base Up function is activated, current flows thru the hand / foot control, back to the PC board. Circuitry on the PC Board supplies approximately 48 VDC to the base actuator motor.

The actuator motor runs and raises the table.

NOTE

The PC board continuously monitors the Base Up limit switch and the Base position sensor*.

If the Base Up limit switch is tripped (open), the Base Up function will not operate.

If the Base position sensor detects that the table has reached its upper limit, the Base Up function will not operate.*

Actuator Motor runs until:

1. Hand / foot control button is released.
2. Base Up limit switch is tripped.
3. Emergency Stop button* is pressed.
4. Position Sensor* malfunction.
5. Overcurrent protection tripped.
6. Software time-out limit is reached (approx. 25 seconds).

Base Down Operation

When the Base Down function is activated, current flows thru the hand / foot control, back to the PC board. Circuitry on the PC Board supplies approximately 40 VDC to the base actuator motor.

The actuator motor runs and lowers the table.

NOTE

The PC board continuously monitors the Base Down limit switch and the Base position sensor.

If the Base Down limit switch is tripped (open), the Base Down function will not operate.

If the Base position sensor detects that the table is in a potential "crash position", or that the base has reached its lower limit, the Base Down function will not operate.*

Actuator Motor runs until:

1. Hand / foot control button is released.
2. Base Down limit switch is tripped.
3. Emergency Stop button* is pressed.
4. Crash Avoidance System* activated.
5. Position Sensor* malfunction.
6. Overcurrent protection tripped.
7. Software time-out limit is reached (approx. 25 seconds).

* Midmark models only.

[This feature is not available on Ritter models]

Operation & Troubleshooting

Base Up / Down Function - continued

Problem: No Base Up or Base Down

Refer To:	Page
Limit Switches	B-4
Hand & Foot Controls	B-6
Base Actuator	B-11
Main PC Board	B-40
Wiring Diagrams	D-1
Exploded Views / Part Numbers	E-1

1st ✓
Loose / Damaged Wire Connections
(Base Actuator, Base Up/Down Limit Switches, hand/foot control ports, black & white wires between main system transformer & PC board)

3rd ✓
Base Actuator
Refer to: Section B - Base Actuator

4th ✓
Main PC Board
Refer to: Section B - Main PC Board

2nd ✓
Hand / Foot Control
Refer to: Section B - Hand & Foot Controls

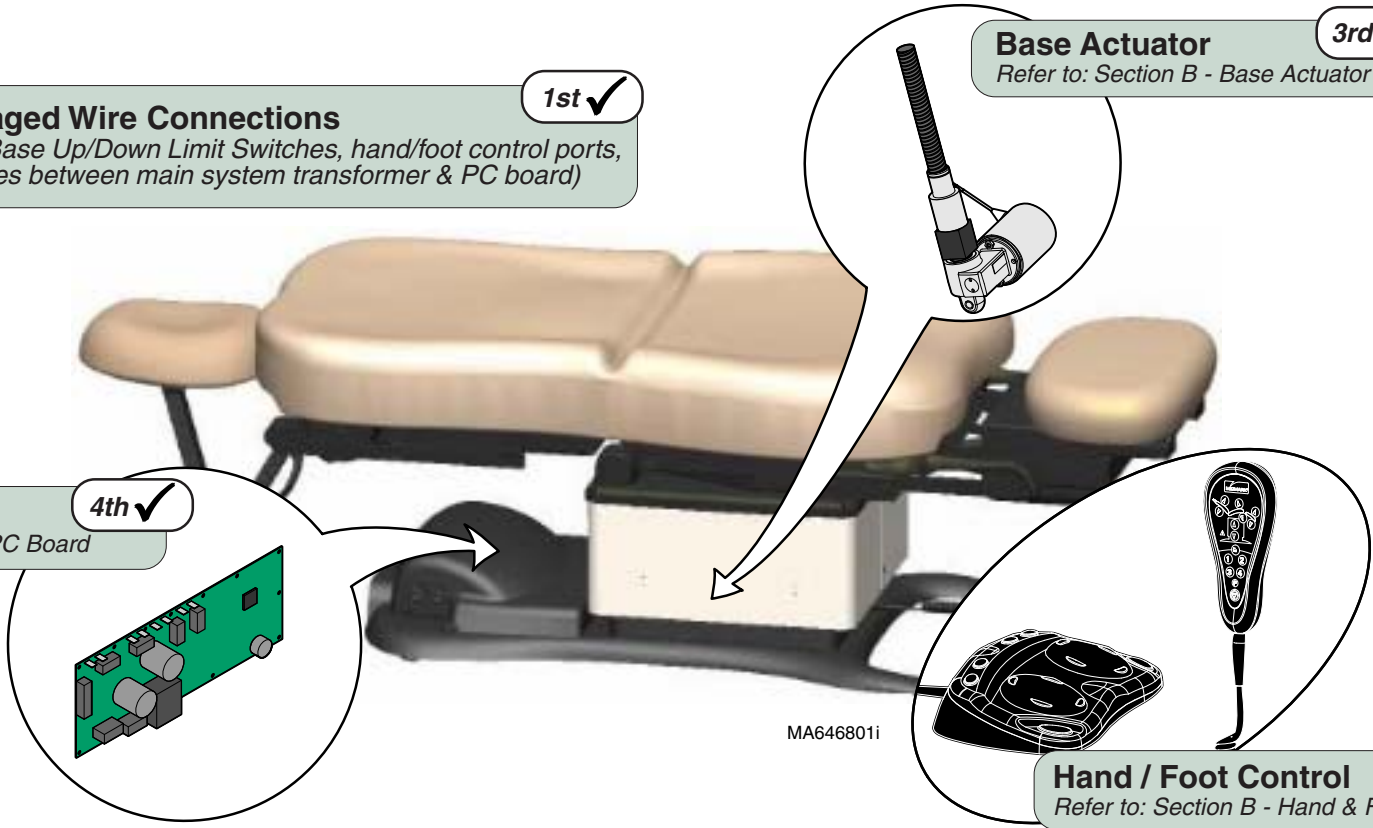

Base Up / Down Function - continued

Problem: No Base Up.
Base Down - OK.

Refer To:	Page
Limit Switches	B-3
Hand & Foot Controls	B-6
Base Actuator	B-11
Main PC Board	B-40
Wiring Diagrams	D-1
Exploded Views / Part Numbers	E-1

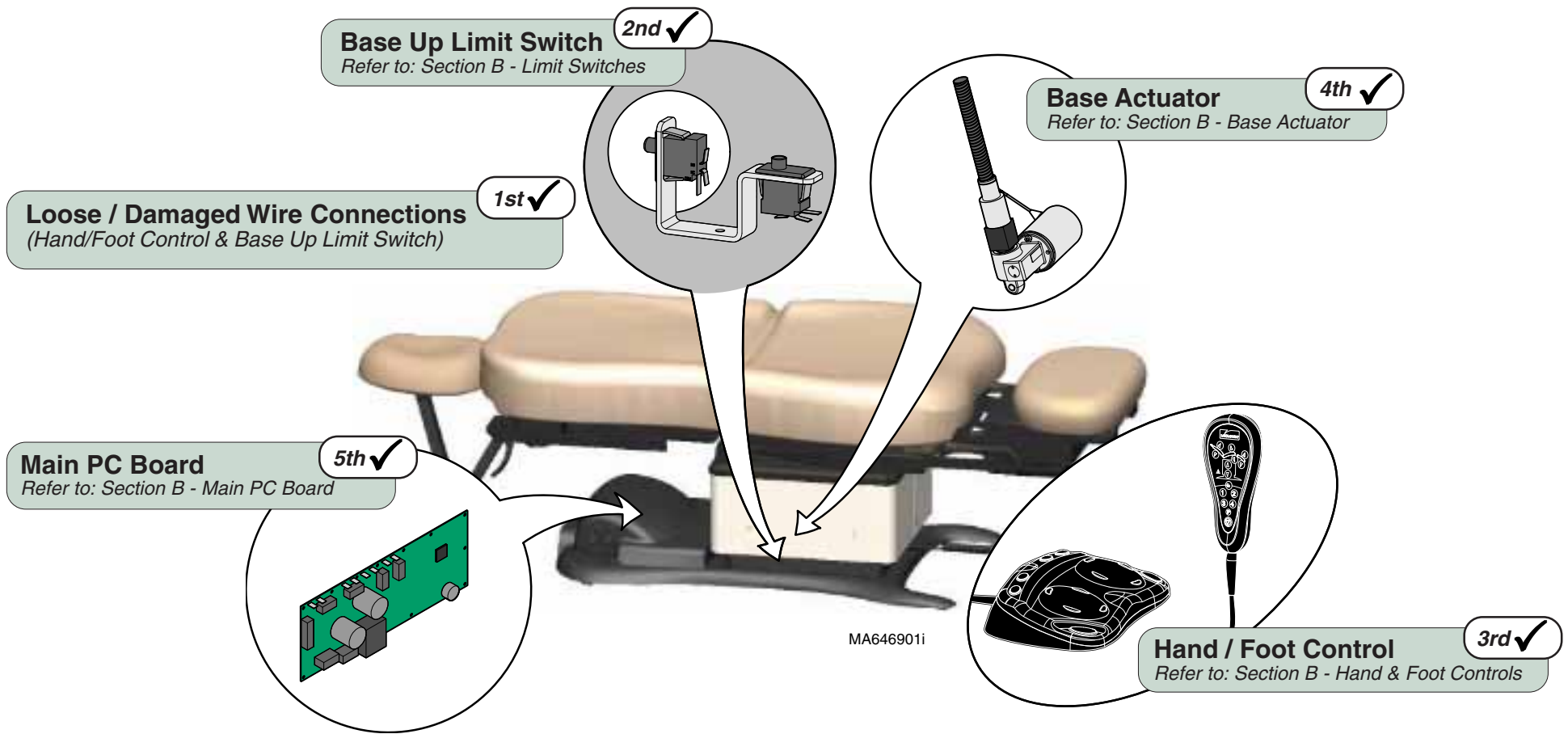

Models: ALL
Serial Numbers:

Base Up / Down

Operation & Troubleshooting

Refer To:	Page
Limit Switches	B-3
Hand & Foot Controls	B-6
Base Actuator	B-11
Main PC Board	B-40
Wiring Diagrams	D-1
Exploded Views / Part Numbers	E-1

Base Up / Down Function - continued

Problem: No Base Down.
Base Up - OK.

[All other table functions - OK]

Base Down Limit Switch 2nd ✓

Refer to: Section B - Limit Switches

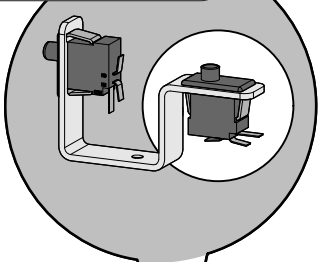

Base Actuator 4th ✓

Refer to: Section B - Base Actuator

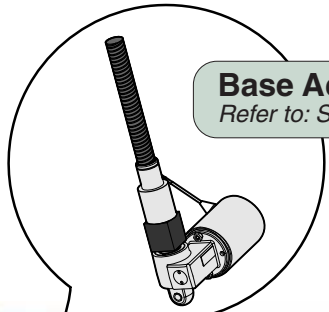

Loose Wire Connections 1st ✓

(Hand/Foot Control & Base Down Limit Switch)

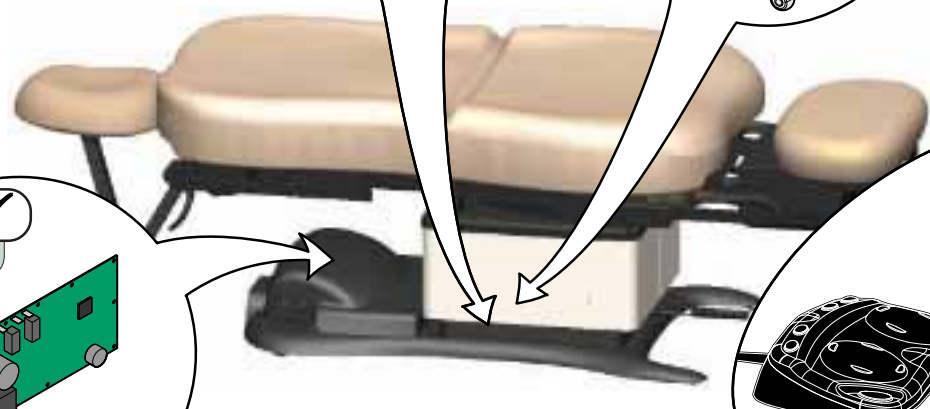

Main PC Board 5th ✓

Refer to: Section B - Main PC Board

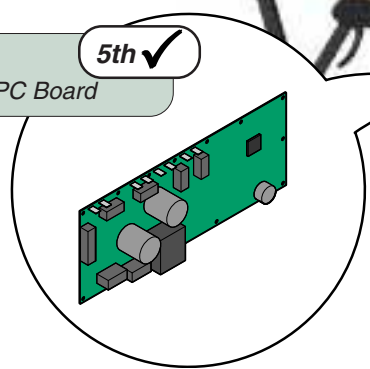

Hand / Foot Control 3rd ✓

Refer to: Section B - Hand & Foot Controls



MA647001i

Base Up / Down Function - continued

Problem: Base drifts down.

Refer To:	Page
Base Actuator	B-11
Wiring Diagrams	D-1
Exploded Views / Part Numbers	E-1

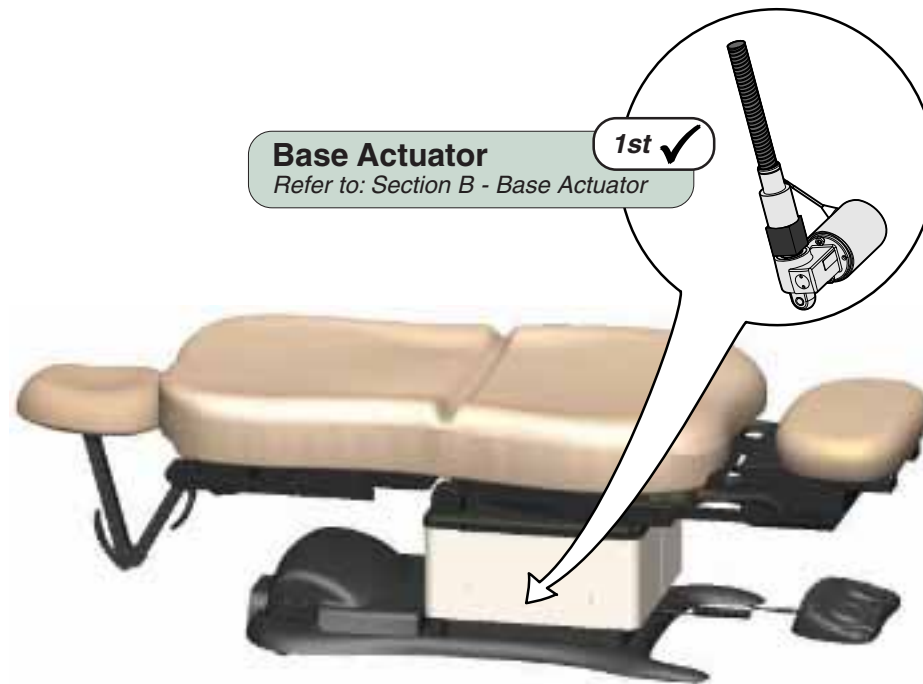

MA647101i

Models:
Serial Numbers:

ALL

Base Up / Down

Operation & Troubleshooting

Base Up / Down Function - continued
Problem: Noisy operation. (Grinding, squeaking, etc)

Refer To:	Page
Base Actuator	B-11
Gas Springs	B-28
Base Shroud Removal	C-5
Wiring Diagrams	D-1
Exploded Views / Part Numbers	E-1

2nd ✓
Clean / lubricate base actuator threads.
 Recommended lubricant: Lithium grease

4th ✓
Base Actuator
 Refer to: Section B - Base Actuator

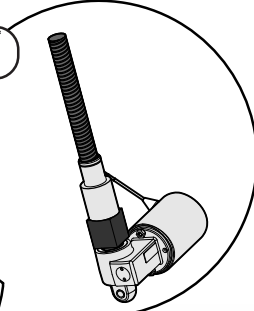

3rd ✓
Wipe guide bars with a clean, dry cloth.
 NEVER lubricate base slides / scissor mechanism.
 Refer to: Section C - Base Shroud Removal

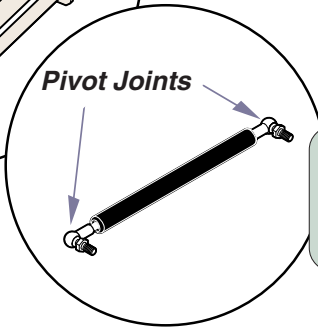
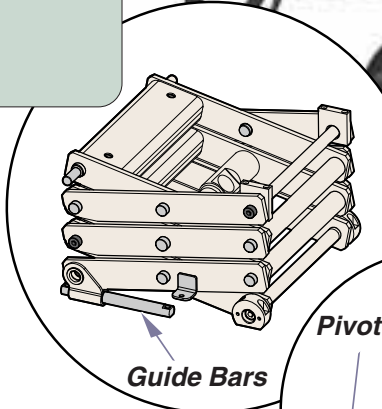

1st ✓
Clean / lubricate gas spring pivot joints
 Recommended lubricant: Lithium grease
 Refer to: Section B - Gas Springs

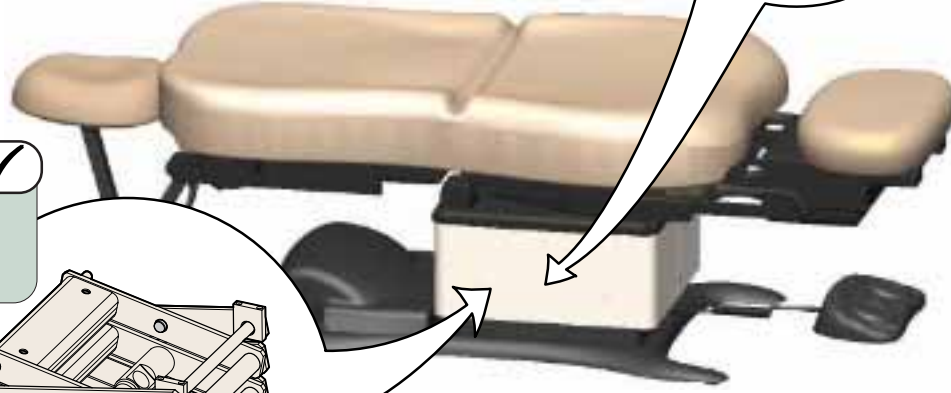

MA647201i

Base Up / Down Function - continued

Problem: Moves slowly - and/or
Will not lift patient.

Refer To:	Page
General Information (Specifications).....	ii
Base Actuator	B-11
Gas Springs	B-28
Wiring Diagrams	D-1
Exploded Views / Part Numbers	E-1

Base Actuator

Refer to: Section B - Base Actuator

4th ✓

Did patient exceed 450 lb. weight limit?

Inform staff that max. patient weight is 450 lbs.

Refer to: General Information Section

1st ✓

450
lbs.

MA647301i

Gas Springs

Refer to: Section B - Gas Springs

3rd ✓

2nd ✓

Low voltage to table

Required voltage:

115 VAC setting 115 ±10% VAC

230 VAC setting 230 ±10% VAC

Models:
Serial Numbers:

ALL

Base Up / Down

Operation & Troubleshooting

Base Up / Down Function - continued

Problem: Base Up and/or Base Down moves briefly, then stops ("beeps").

Refer To:	Page
Base Actuator	B-11
Position Sensors	B-32
Main PC Board	B-40
Wiring Diagrams	D-1
Exploded Views / Part Numbers	E-1

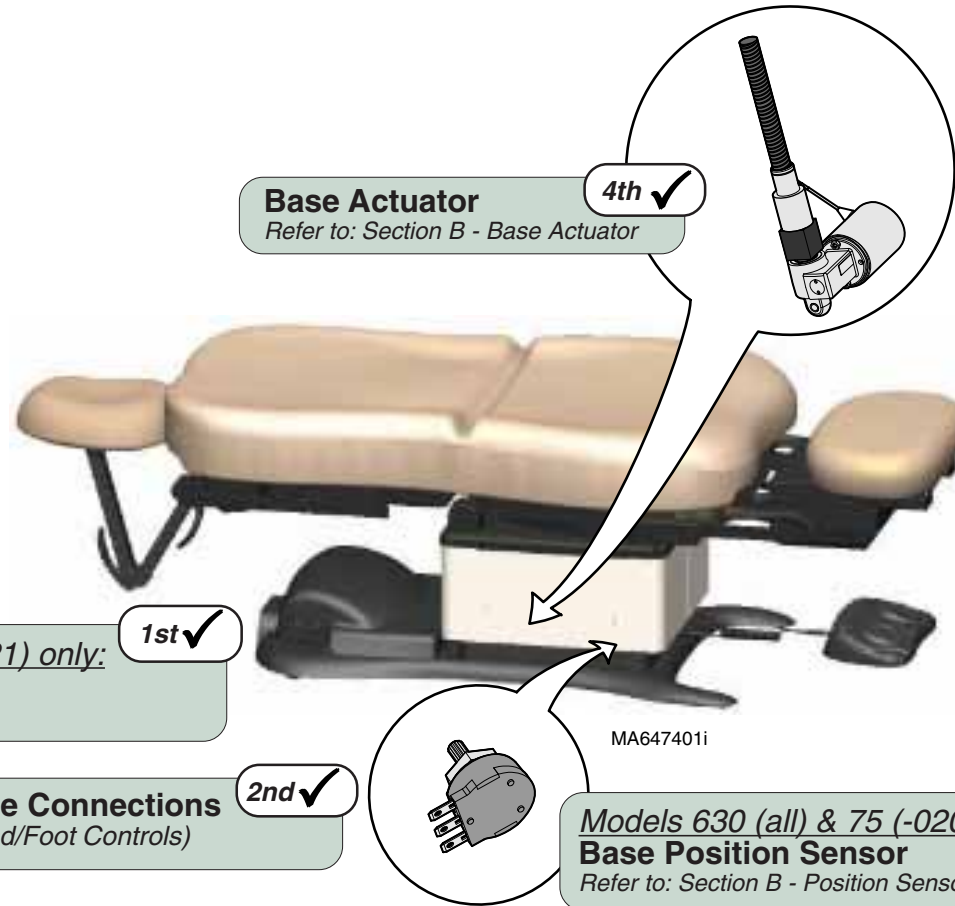

This page intentionally blank.

Operation & Troubleshooting

Back UP / DOWN Function

This illustration shows only the components that affect the Back UP / DOWN function. Refer to the following page for a detailed description of Back UP / DOWN operation.

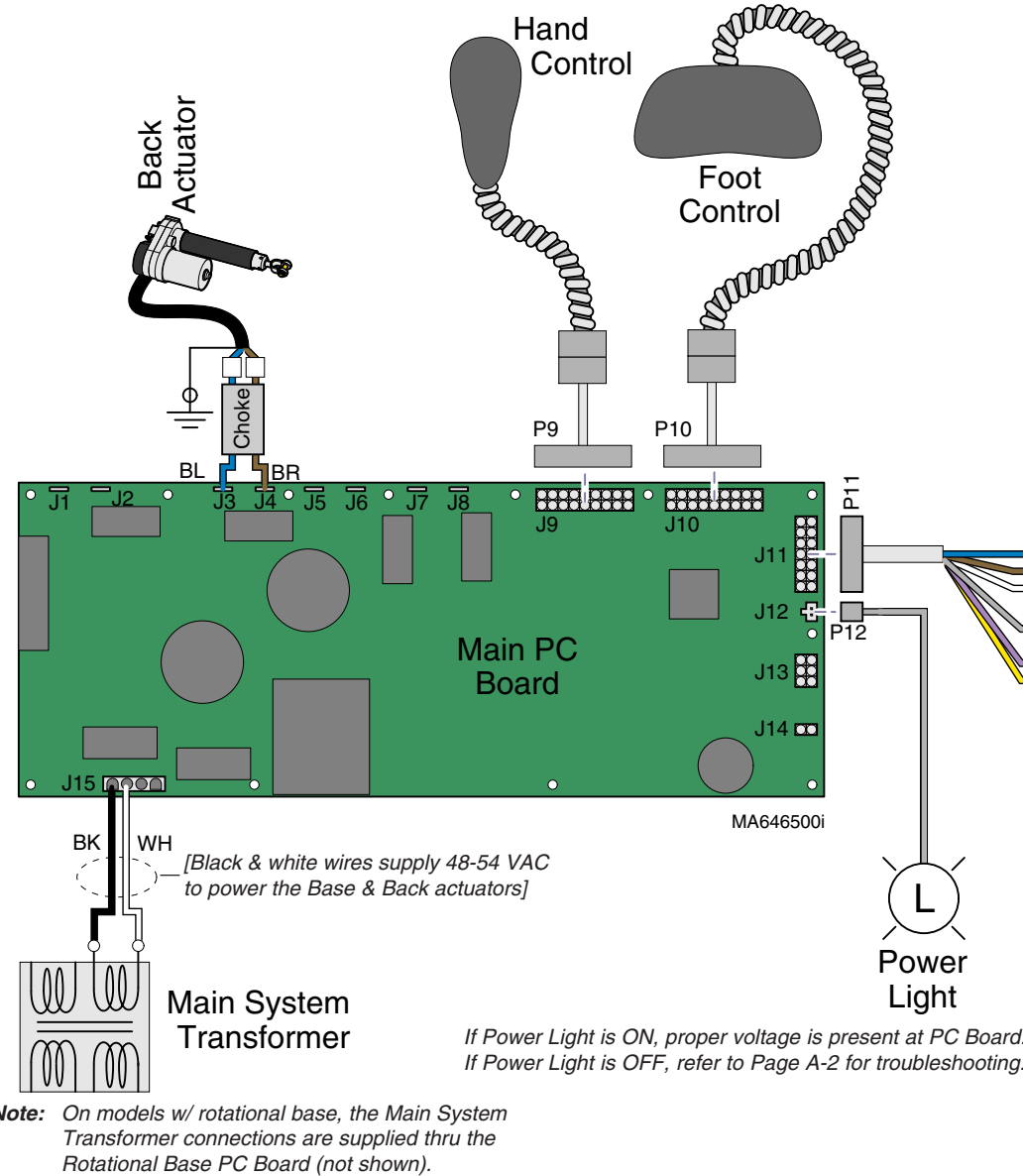

Note: On models w/ rotational base, the Main System Transformer connections are supplied thru the Rotational Base PC Board (not shown).

Troubleshooting

[Back Up / Down Function]

Problem	Page
No Back UP or DOWN	A-20
No Back UP (DOWN - OK)	A-21
No Back DOWN (UP - OK)	A-22
All other table functions - OK	A-22
No Back Down / Base Down / Tilt Up	A-48
Back Drifts Down	A-23
Noisy Operation	A-24
Moves Slowly	A-25
Up / Down Function	
Moves Briefly, then Stops	A-26
Headrest Collides w/Floor	A-48

Only the wires that affect the Back Function are shown.

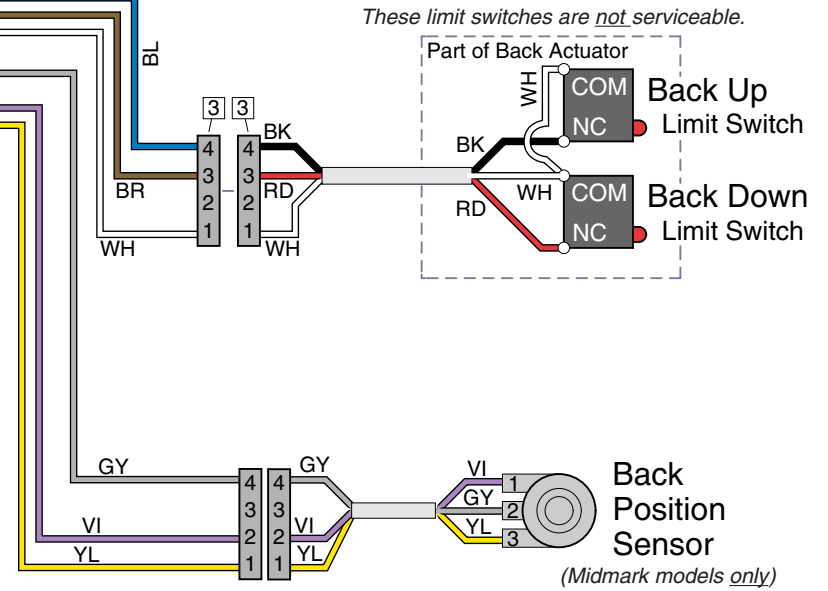

Back UP / DOWN Function

Is There Power To The Table?

When voltage is present at the PC board, the power light is illuminated.

[Refer to 'Power To The Table' (page A-2), for description of current flow to the PC board].

Power To Foot / Hand Controls

Circuitry on the PC board supplies 8-10 VAC to the hand / foot control connection ports.

Back Up Operation

When the Back Up function is activated, current flows thru the hand / foot control, back to the PC board. Circuitry on the PC Board supplies approximately 48 VDC to the back actuator motor.

The actuator motor runs and raises the back section.

NOTE

The PC board continuously monitors the Back Up limit switch (*mounted inside the actuator*) and the Back position sensor*.

If the Back Up limit switch is tripped (open), the Back Up function will not operate.

If the Back position sensor detects that the back section has reached its upper limit, the Back Up function will not operate.

Actuator Motor runs until:

1. Hand / foot control button is released.
2. Back Up limit switch is tripped.
3. Emergency Stop button* is pressed.
4. Position Sensor* malfunction.
5. Overcurrent protection tripped.
6. Software time-out limit is reached (*approx. 30 seconds*).

* Midmark models only.

[This feature is not available on Ritter models]

Back Down Operation

When the Back Down function is activated, current flows thru the hand / foot control, back to the PC board. Circuitry on the PC Board supplies approximately 44 VDC to the back actuator motor.

The actuator motor runs and lowers the back section.

NOTE

The PC board continuously monitors the Back Down limit switch (*mounted inside the actuator*) and the Back position sensor*.

If the Back Down limit switch is tripped (open), the Back Down function will not operate.

If the Back position sensor detects that the table is in a potential "crash position", or that the back section has reached its lower limit, the Back Down function will not operate.

Actuator Motor runs until:

1. Hand / foot control button is released.
2. Back Down limit switch is tripped.
3. Emergency Stop button* is pressed.
4. Crash Avoidance System* activated.
5. Position Sensor* malfunction.
6. Overcurrent protection tripped.
7. Software time-out limit is reached (*approx. 30 seconds*).

Operation & Troubleshooting

Back Up / Down Function - continued

Problem: No Back Up or Back Down.

Refer To:	Page
Hand & Foot Controls	B-6
Back Actuator	B-17
Main PC Board	B-40
Wiring Diagrams	D-1
Exploded Views / Part Numbers	E-1

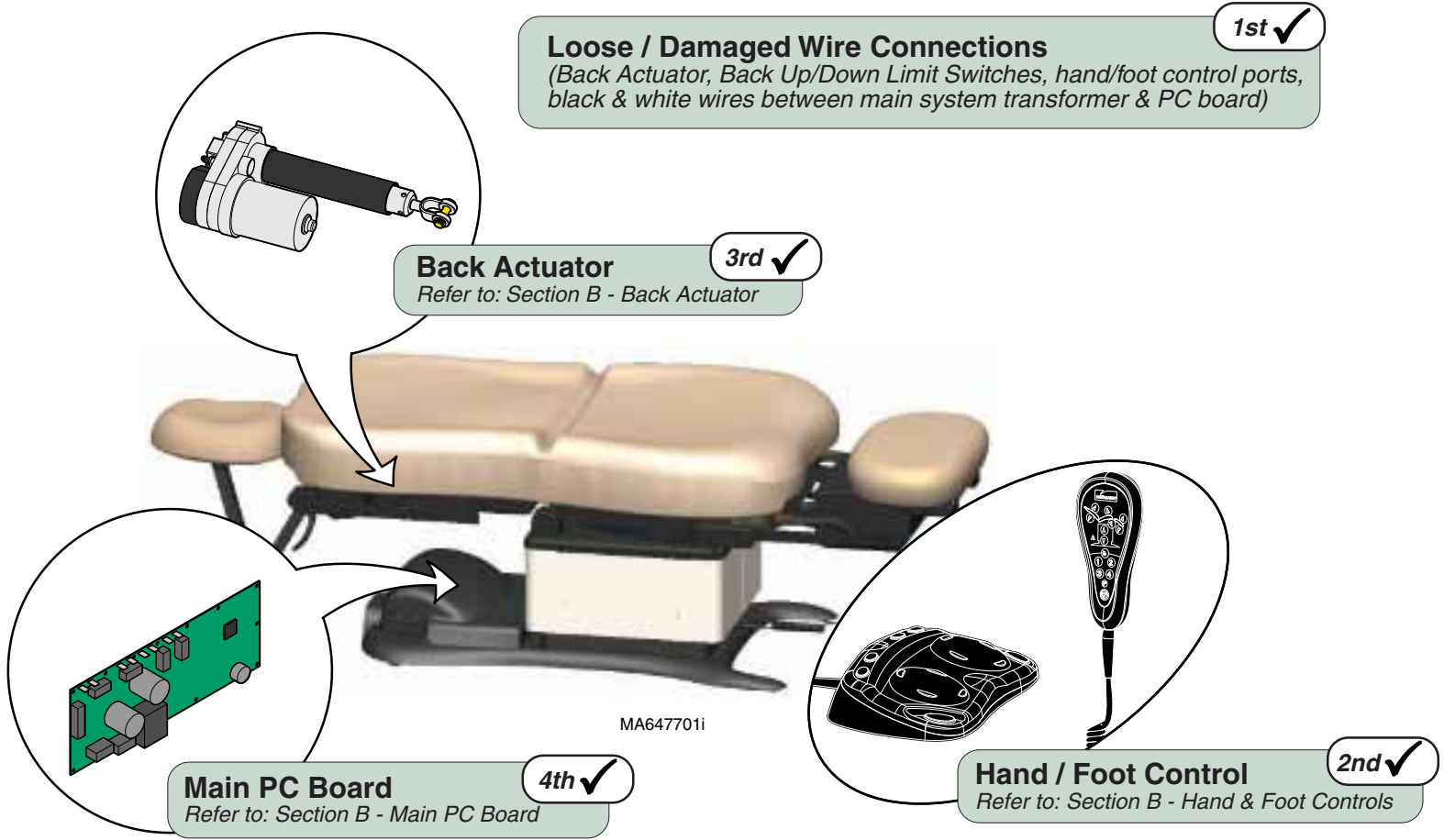

1st ✓
Loose / Damaged Wire Connections
(Back Actuator, Back Up/Down Limit Switches, hand/foot control ports, black & white wires between main system transformer & PC board)

3rd ✓
Back Actuator
Refer to: Section B - Back Actuator

4th ✓
Main PC Board
Refer to: Section B - Main PC Board

2nd ✓
Hand / Foot Control
Refer to: Section B - Hand & Foot Controls

MA647701i

Back Up / Down Function - continued

Problem: No Back Up.
Back Down - OK.

Refer To:	Page
Hand & Foot Controls	B-6
Back Actuator	B-17
Main PC Board	B-40
Wiring Diagrams	D-1
Exploded Views / Part Numbers	E-1

Back Actuator

Refer to: Section B - Back Actuator

3rd ✓

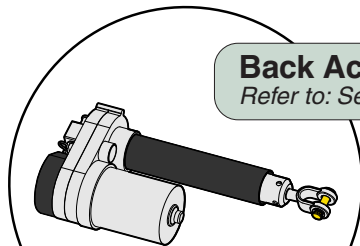

Loose / Damaged Wire Connections (Hand/Foot Control & Back Up Limit Switch)

1st ✓

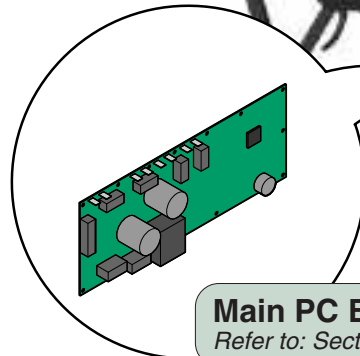
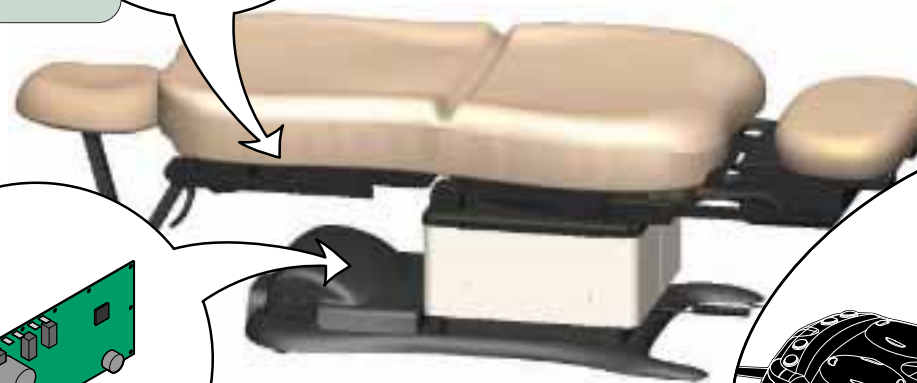

Main PC Board

Refer to: Section B - Main PC Board

4th ✓

MA647701i



Hand / Foot Control

Refer to: Section B - Hand & Foot Controls

2nd ✓

Models:
Serial Numbers:

ALL

Back Up / Down

Operation & Troubleshooting

Refer To:	Page
Limit Switches	B-4
Hand & Foot Controls	B-6
Back Actuator	B-17
Main PC Board	B-40
Wiring Diagrams	D-1
Exploded Views / Part Numbers	E-1

Back Up / Down Function - continued

Problem: No Back Down.
Back Up - OK.

[All other table functions - OK]

Loose / Damaged Wire Connections
(Hand/Foot Control & Back Down Limit Switch)

1st ✓

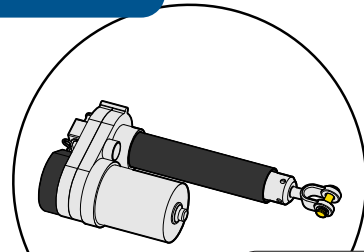

Back Actuator
Refer to: Section B - Back Actuator

3rd ✓

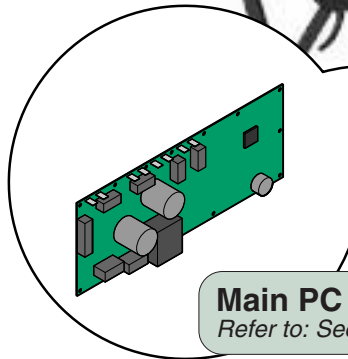

Main PC Board
Refer to: Section B - Main PC Board

4th ✓



MA647701i



Hand / Foot Control
Refer to: Section B - Hand & Foot Controls

2nd ✓

Back Up / Down Function - continued

Problem: Back drifts down.

Refer To:	Page
Back Actuator	B-17
Wiring Diagrams	D-1
Exploded Views / Part Numbers	E-1

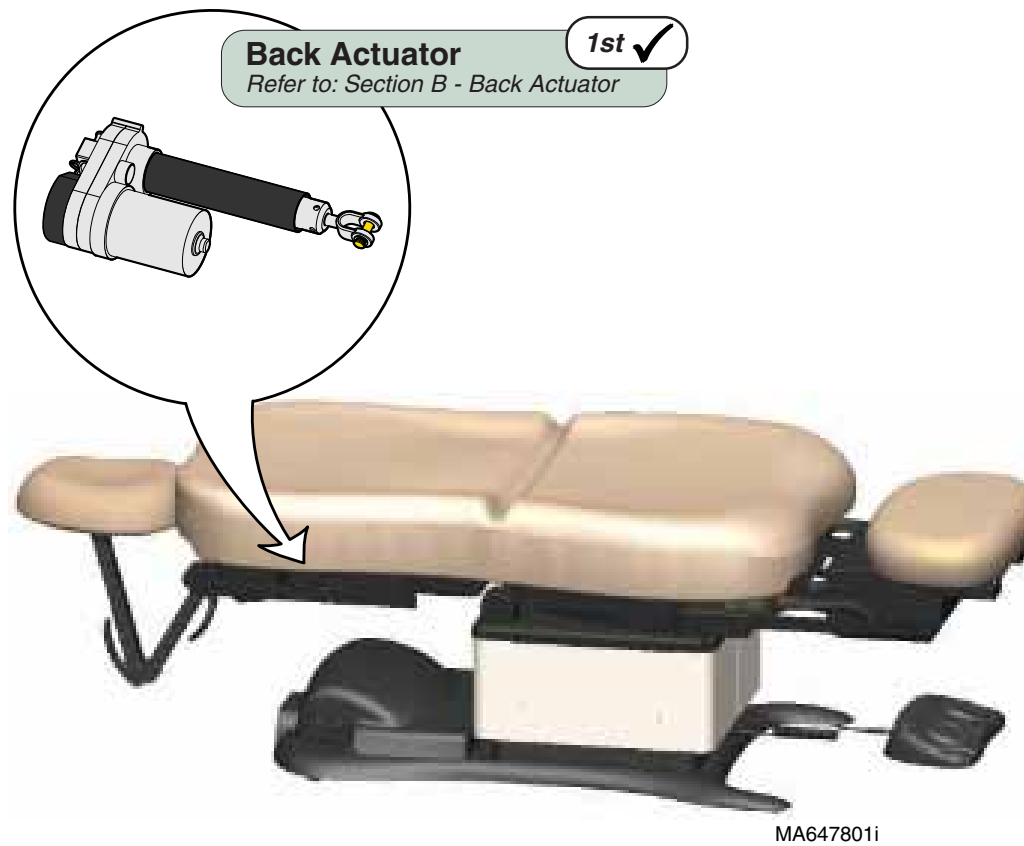

Models:
Serial Numbers:

ALL

Back Up / Down

Operation & Troubleshooting

Back Up / Down Function - *continued*

Refer To:	Page
Back Actuator	B-17
Wiring Diagrams	D-1
Exploded Views / Part Numbers	E-1

Problem: *Noisy operation.
(Grinding, squeaking, etc)*

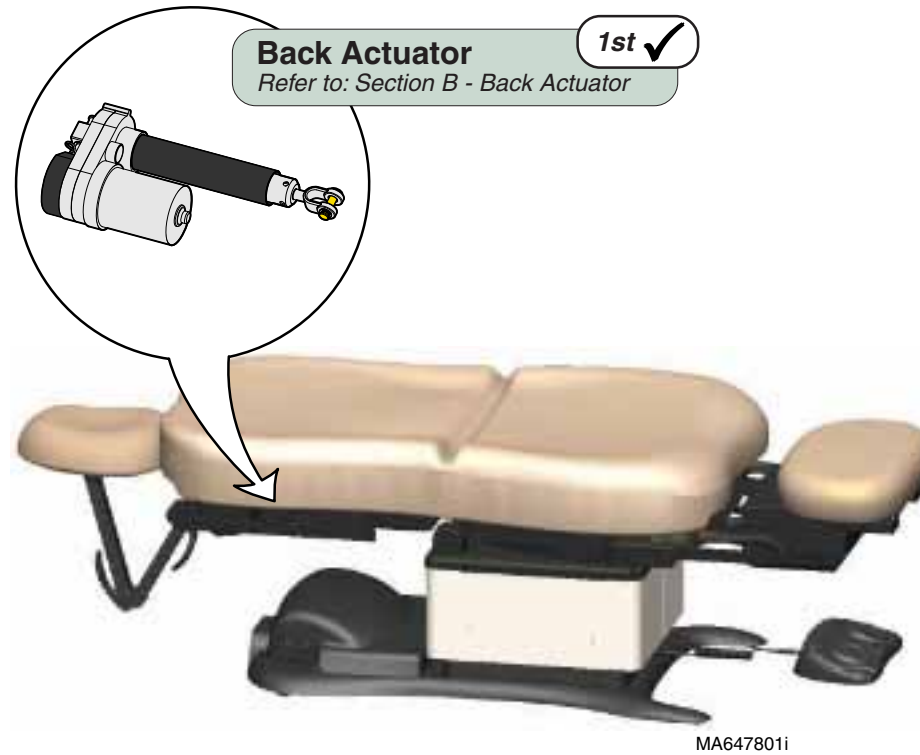

Operation & Troubleshooting

Back Up / Down Function - continued

Problem: Moves slowly - and/or
Will not lift patient.

Refer To:	Page
General Information (<i>Specifications</i>).....	ii
Back Actuator	B-17
Wiring Diagrams	D-1
Exploded Views / Part Numbers	E-1

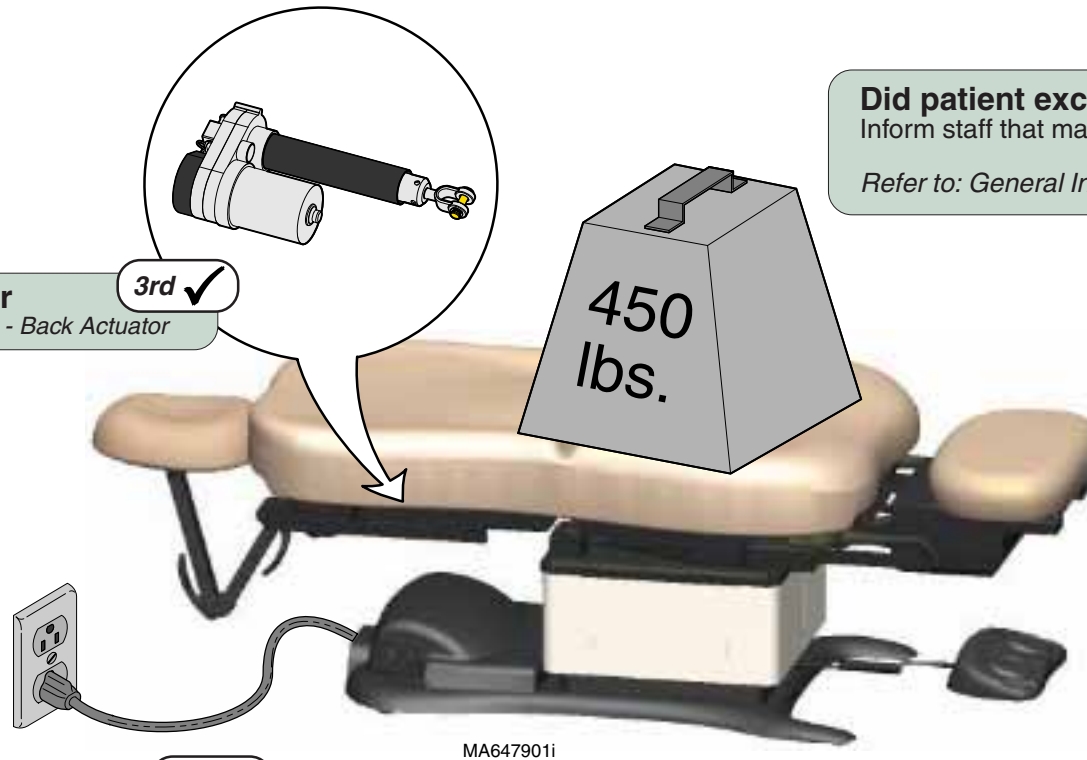

Back Actuator
Refer to: Section B - Back Actuator

3rd ✓

Did patient exceed 450 lb. weight limit?
Inform staff that max. patient weight is 450 lbs.

1st ✓

Refer to: General Information Section

Low voltage to table

Required voltage:
115 VAC setting 115 ±10% VAC
230 VAC setting 230 ±10% VAC

2nd ✓

Models:
Serial Numbers:

ALL

Back Up / Down

A-25

Operation & Troubleshooting

Back Up / Down Function - continued

Problem: Back Up *and/or* Back Down moves briefly, then stops ("beeps").

Refer To:	Page
Back Actuator	B-17
Position Sensors	B-32
Main PC Board	B-40
Wiring Diagrams	D-1
Exploded Views / Part Numbers	E-1

4th ✓
Back Actuator
 Refer to: Section B - Back Actuator

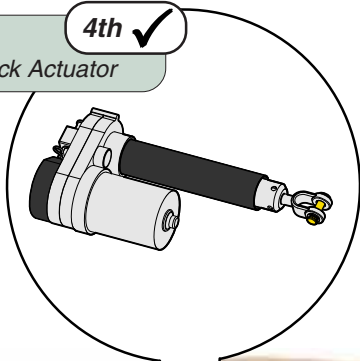

3rd ✓
Models 630 (all) & 75 (-020 /-021) only:
Back Position Sensor
 Refer to: Section B - Position Sensors

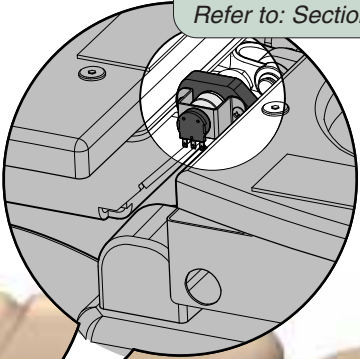

1st ✓
Models 630 (all) & 75 (-020 /-021) only:
Calibrate PC Board
 Refer to: Section B - Main PC Board

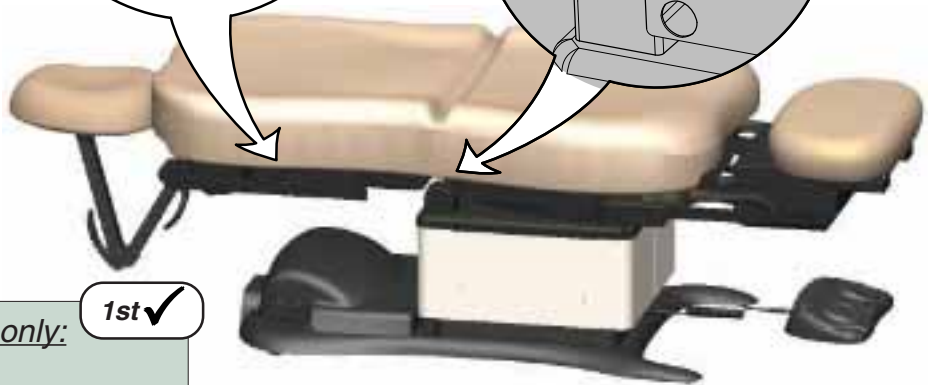

MA648001i

2nd ✓
Loose / Damaged Wire Connections
 (Back Position Sensor, Hand/Foot Controls)

This page intentionally blank.

Operation & Troubleshooting

Tilt UP / DOWN Function

This illustration shows only the components that affect the Tilt UP / DOWN function. Refer to the following page for a detailed description of Tilt UP / DOWN operation.

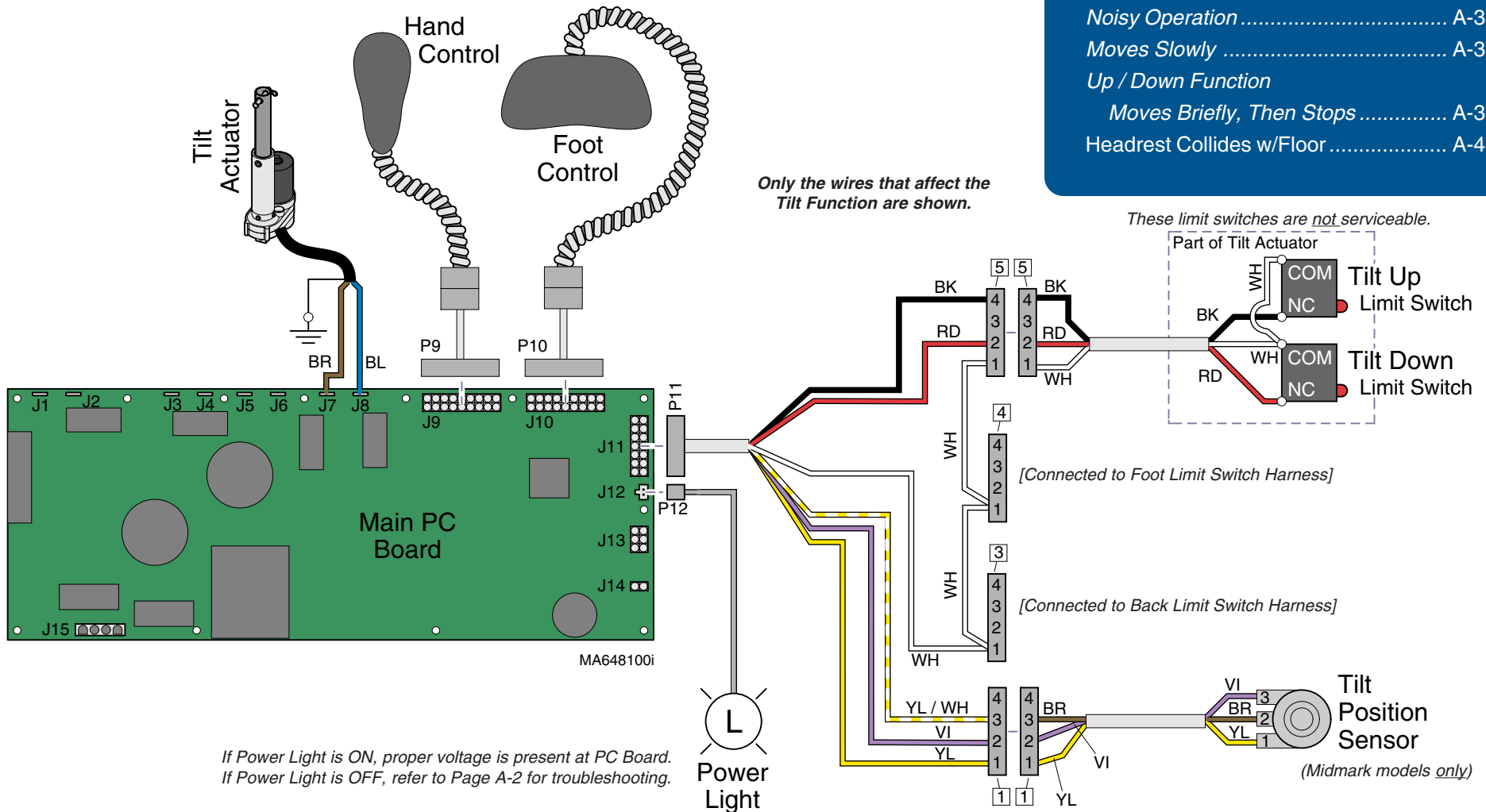

Troubleshooting

[Tilt Up / Down Function]

Problem	Page
No Tilt UP or DOWN.....	A-30
No Tilt DOWN (UP - OK)	A-31
No Tilt UP (DOWN - OK)	
All other table functions - OK	A-32
No Tilt Up / Base Down / Back Down	A-48
Seat Drifts Down	A-33
Noisy Operation	A-34
Moves Slowly	A-35
Up / Down Function	
Moves Briefly, Then Stops	A-36
Headrest Collides w/Floor	A-48

Tilt UP / DOWN Function

Is There Power To The Table?

When voltage is present at the PC board, the power light is illuminated.

[Refer to 'Power To The Table' (page A-2), for description of current flow to the PC board].

Power To Foot / Hand Controls

Circuitry on the PC board supplies 8-10 VAC to the hand / foot control connection ports.

Tilt Up Operation

When the Tilt Up function is activated, current flows thru the hand / foot control, back to the PC board. Circuitry on the PC Board supplies approximately 48 VDC to the tilt actuator motor.

The actuator motor runs and reclines the seat section.

NOTE

The PC board continuously monitors the Tilt Up limit switch (*mounted inside the actuator*) and the Tilt position sensor*.

If the Tilt Up limit switch is tripped (open), the Tilt Up function will not operate.

If the Tilt position sensor detects that the table is in a potential "crash position", or that the seat section has reached its upper limit, the Tilt Up function will not operate.

Actuator Motor runs until:

1. Hand / foot control button is released.
2. Tilt Up limit switch is tripped.
3. Emergency Stop button* is pressed.
4. Crash Avoidance System* activated.
5. Position Sensor* malfunction.
6. Overcurrent protection tripped.
7. Software time-out limit is reached.
(*approx. 30 seconds*).

* Midmark models only.
[This feature is not available on Ritter models]

Tilt Down Operation

When the Tilt Down function is activated, current flows thru the hand / foot control, back to the PC board. Circuitry on the PC Board supplies approximately 48 VDC to the tilt actuator motor.

The actuator motor runs and brings the seat section back to a flat position.

NOTE

The PC board continuously monitors the Tilt Down limit switch (*mounted inside the actuator*) and the Tilt position sensor*.

If the Tilt Down limit switch is tripped (open), the Tilt Down function will not operate.

If the Tilt position sensor detects that the seat section has reached its lower limit, the Tilt Down function will not operate.

Actuator Motor runs until:

1. Hand / foot control button is released.
2. Tilt Down limit switch is tripped.
3. Emergency Stop button* is pressed.
4. Position Sensor* malfunction.
5. Overcurrent protection tripped.
6. Software time-out limit is reached
(*approx. 30 seconds*).

Operation & Troubleshooting

Tilt Up / Down Function - continued

Problem: No Tilt Up or Tilt Down.

Refer To:	Page
Limit Switches	B-4
Hand & Foot Controls	B-6
Tilt Actuator	B-21
Main PC Board	B-40
Wiring Diagrams	D-1
Exploded Views / Part Numbers	E-1

1st ✓
Loose / Damaged Wire Connections
(Tilt Actuator, Tilt Up/Down Limit Switches, & hand/foot control ports)

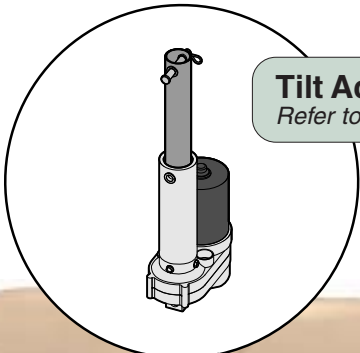

3rd ✓
Tilt Actuator
Refer to: Section B - Tilt Actuator

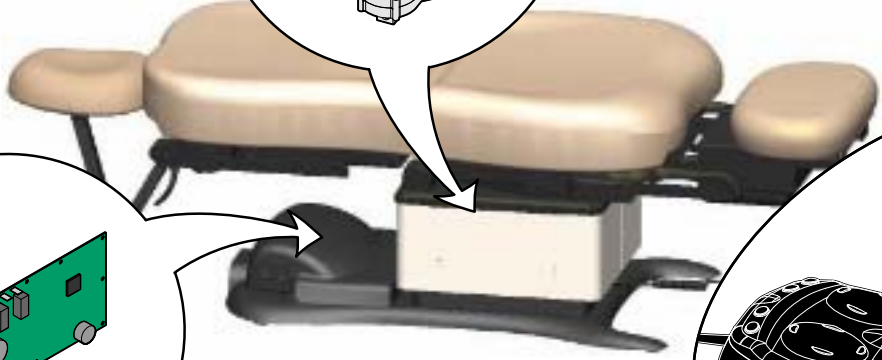

MA64820i

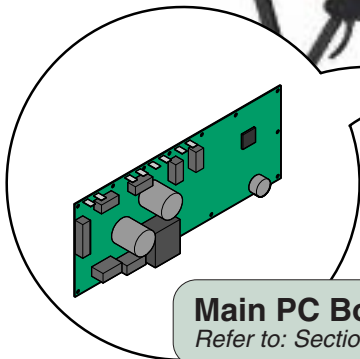

4th ✓
Main PC Board
Refer to: Section B - Main PC Board



2nd ✓
Hand / Foot Control
Refer to: Section B - Hand & Foot Controls

Tilt Up / Down Function - continued

Problem: No Tilt Down.
Tilt Up - OK.

Refer To:	Page
Hand & Foot Controls	B-6
Tilt Actuator	B-21
Main PC Board	B-40
Wiring Diagrams	D-1
Exploded Views / Part Numbers	E-1

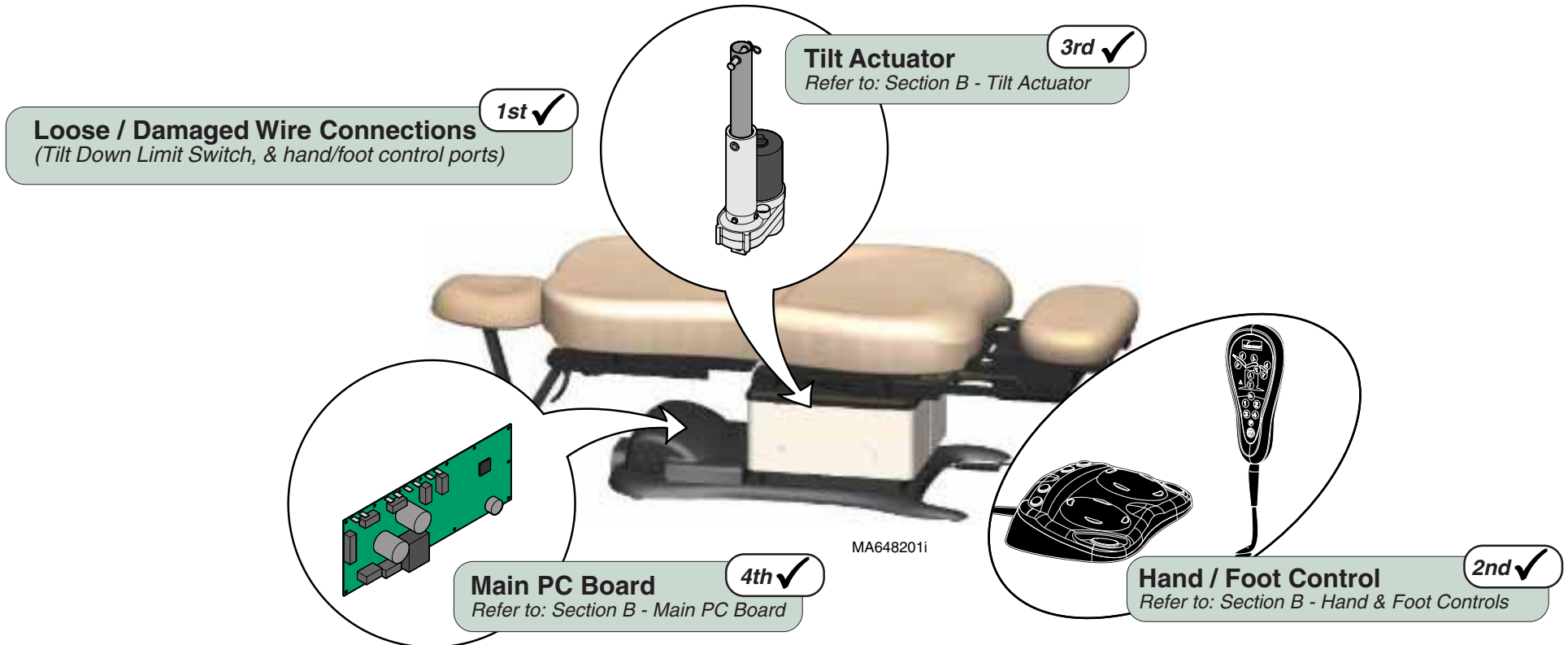

Models:
Serial Numbers:

ALL

Tilt Up / Down

Operation & Troubleshooting

Refer To:	Page
Hand & Foot Controls	B-6
Tilt Actuator	B-21
Main PC Board	B-40
Wiring Diagrams	D-1
Exploded Views / Part Numbers	E-1

Tilt Up / Down Function - *continued*

Problem: No Tilt Up.
Tilt Down - OK.

[All other table functions - OK]

Loose / Damaged Wire Connections
(Tilt Up Limit Switch, & hand/foot control ports)

1st ✓

Tilt Actuator
Refer to: Section B - Tilt Actuator

3rd ✓

Main PC Board
Refer to: Section B - Main PC Board

4th ✓

Hand / Foot Control
Refer to: Section B - Hand & Foot Controls

2nd ✓

MA648201i

Tilt Up / Down Function - continued

Problem: Seat drifts down.

Refer To:	Page
Tilt Actuator	B-21
Wiring Diagrams	D-1
Exploded Views / Part Numbers	E-1

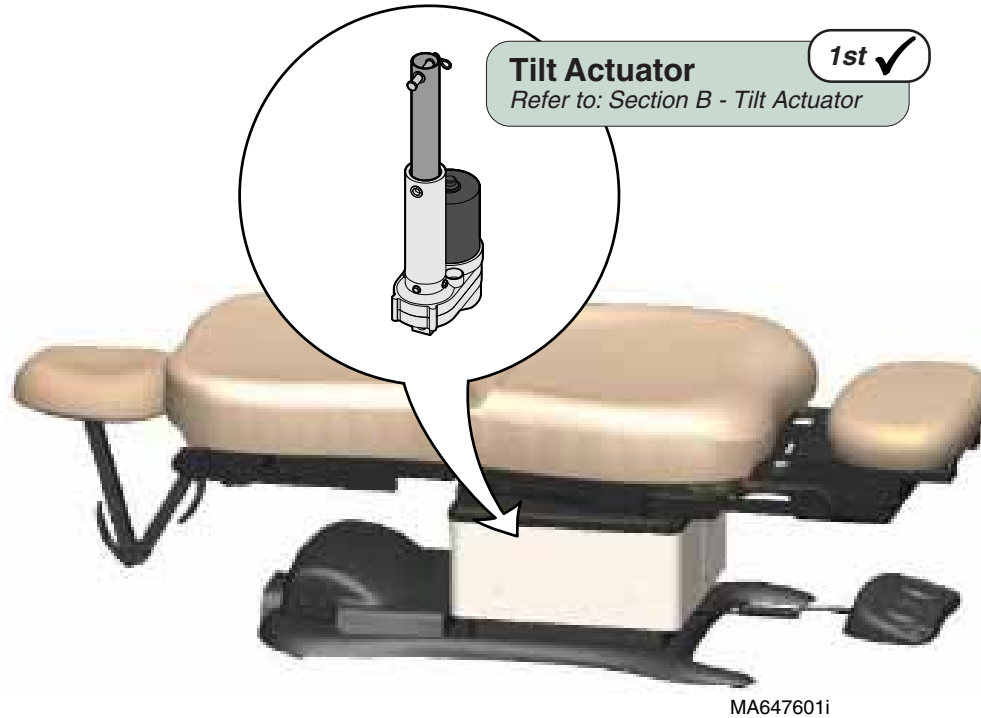

Models:
Serial Numbers:

ALL

Tilt Up / Down

Operation & Troubleshooting

Tilt Up / Down Function - continued

Refer To:	Page
Tilt Actuator	B-21
Wiring Diagrams	D-1
Exploded Views / Part Numbers	E-1

Problem: Noisy operation.
(Grinding, squeaking, etc)

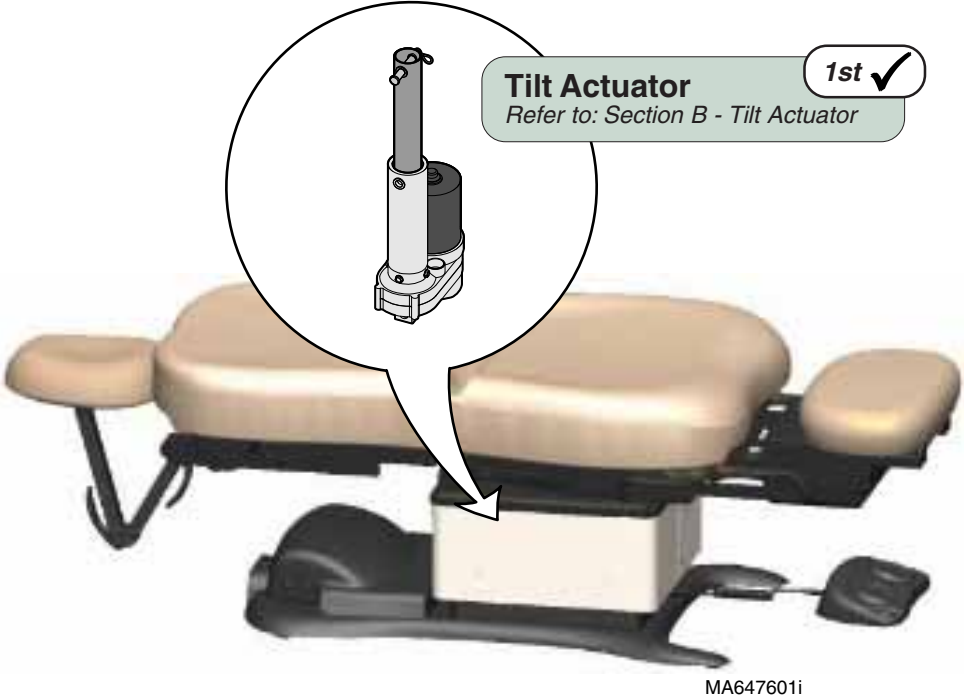

Tilt Up / Down Function - continued

Problem: Moves slowly - and/or
Will not lift patient.

Refer To:	Page
General Information (Specifications).....	ii
Tilt Actuator	B-21
Wiring Diagrams	D-1
Exploded Views / Part Numbers	E-1

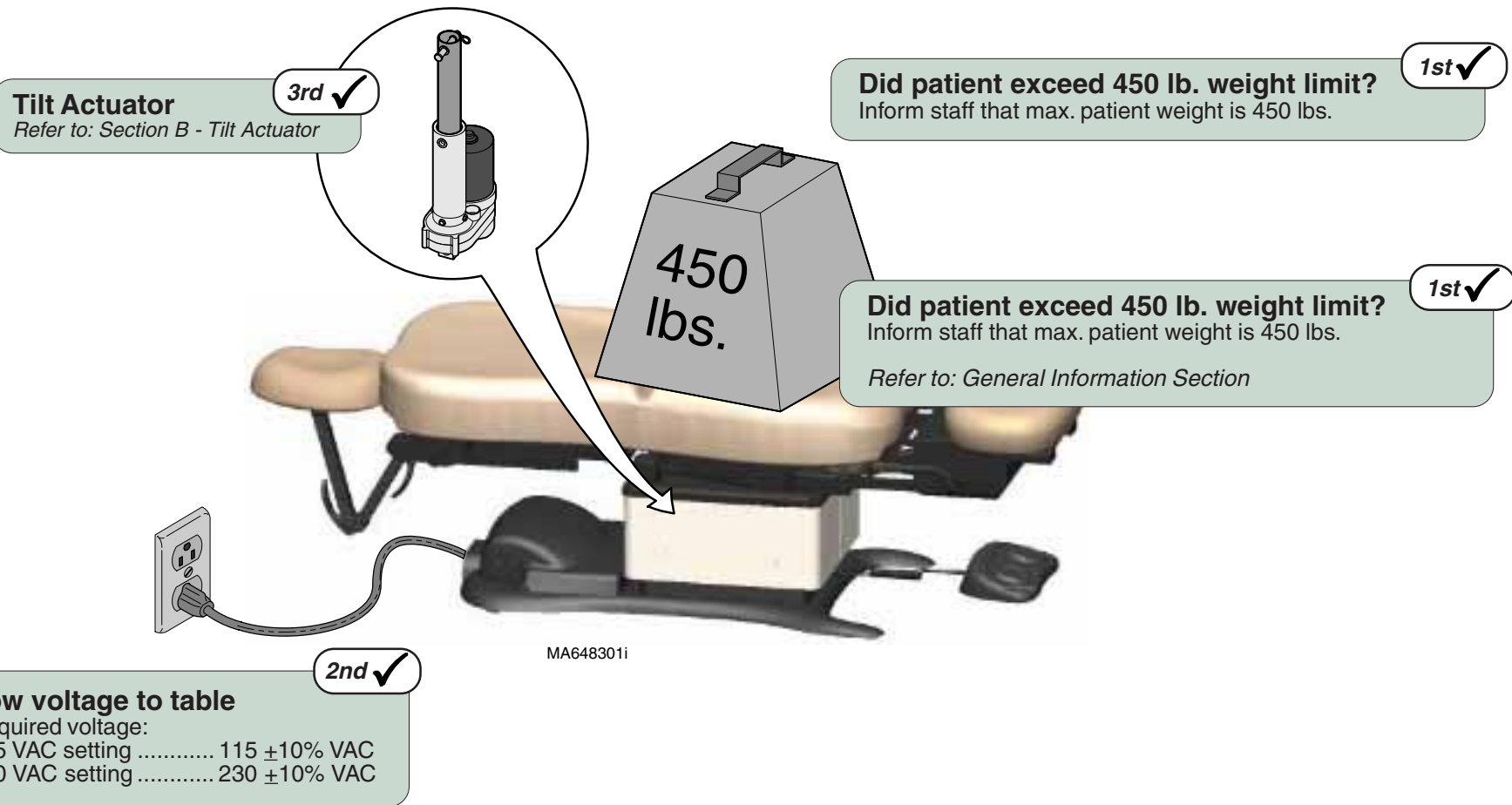

Models:
Serial Numbers:

ALL

Tilt Up / Down

Operation & Troubleshooting

Tilt Up / Down Function - continued

Problem: Tilt Up *and/or* Tilt Down moves briefly, then stops ("beeps").

Refer To:	Page
Tilt Actuator	B-21
Position Sensors	B-32
Main PC Board	B-40
Wiring Diagrams	D-1
Exploded Views / Part Numbers	E-1

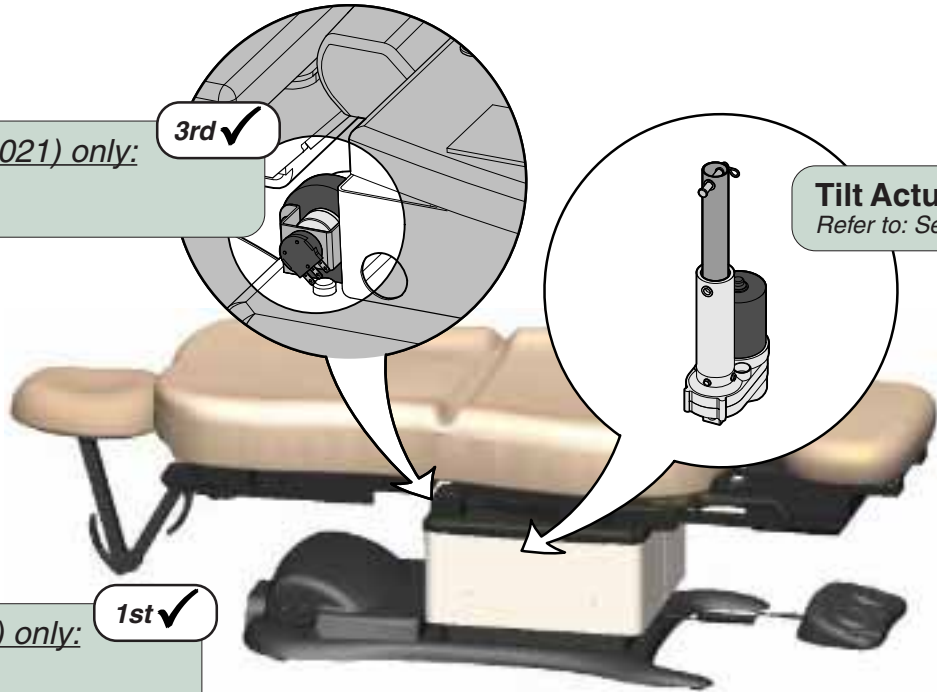

Models 630 (all) & 75 (-020 /-021) only:
Tilt Position Sensor
 Refer to: Section B - Position Sensors

3rd ✓

Tilt Actuator
 Refer to: Section B - Tilt Actuator

4th ✓

Models 630 (all) & 75 (-020 /-021) only:
Calibrate PC Board
 Refer to: Section B - Main PC Board

1st ✓

Loose / Damaged Wire Connections
 (Tilt Position Sensor, Hand/Foot Controls)

2nd ✓

This page intentionally blank.

Operation & Troubleshooting

Foot UP / DOWN Function

This illustration shows only the components that affect the Foot UP / DOWN function. Refer to the following page for a detailed description of Foot UP / DOWN operation.

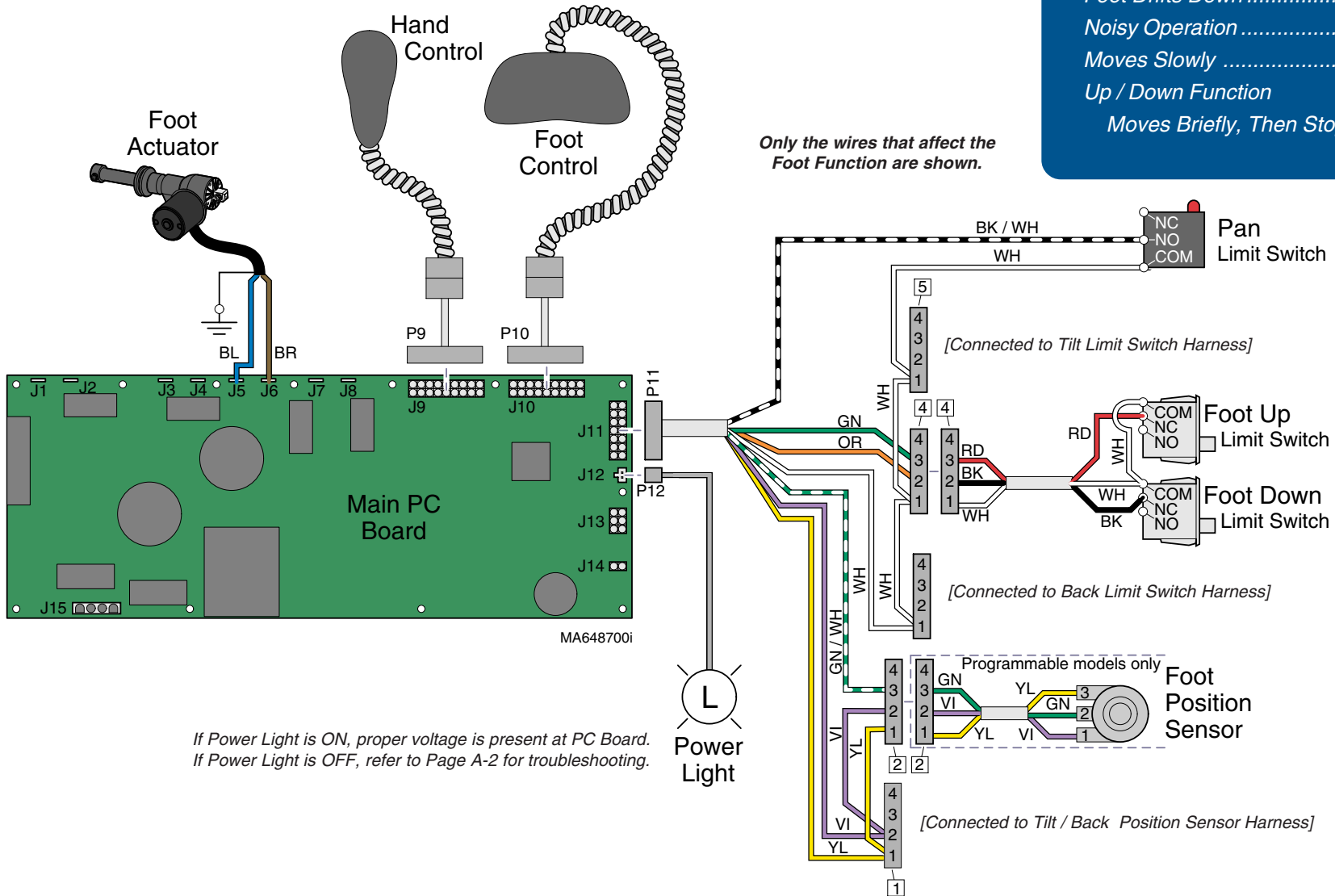

Troubleshooting

[Foot Up / Down Function]

Problem	Page
No Foot UP or DOWN	A-40
No Foot UP (DOWN - OK)	A-41
No Foot DOWN (UP - OK)	A-42
Foot Drifts Down	A-43
Noisy Operation	A-44
Moves Slowly	A-45
Up / Down Function Moves Briefly, Then Stops	A-46

Foot UP / DOWN Function

Is There Power To The Table?

When voltage is present at the PC board, the power light is illuminated.

[Refer to 'Power To The Table' (page A-2), for description of current flow to the PC board].

Power To Foot / Hand Controls

Circuitry on the PC board supplies 8-10 VAC to the hand / foot control connection ports.

Foot Up Operation

When the Foot Up function is activated, current flows thru the hand / foot control, back to the PC board. Circuitry on the PC Board supplies approximately 48 VDC to the foot actuator motor.

The actuator motor runs and raises the foot section.

NOTE

The PC board continuously monitors the Foot Up Limit Switch, the Pan Limit Switch, and the Foot position sensor*.

If the Foot Up Limit Switch is tripped (open), the Foot Up function will not operate.

When the treatment pan (located under the seat section) is pulled out, the Pan Limit Switch opens. If the Pan Limit Switch is open, the Foot Up function will not operate.

If the Foot position sensor detects that the foot section has reached its upper limit, the Foot Up function will not operate.*

Actuator Motor runs until:

1. Hand / foot control button is released.
2. Foot Up limit switch is tripped.
3. Pan Limit Switch opens.
(Treatment pan is pulled out)
3. Emergency Stop button** is pressed.
4. Position Sensor malfunction*.
5. Overcurrent protection tripped.
6. Software time-out limit is reached.
(approx. 20 seconds).

Foot Down Operation

When the Foot Down function is activated, current flows thru the hand / foot control, back to the PC board. Circuitry on the PC Board supplies approximately 48 VDC to the foot actuator motor.

The actuator motor runs and lowers the foot section.

NOTE

The PC board continuously monitors the Foot Down limit switch and the Foot position sensor*.

If the Foot Down limit switch is tripped (open), the Foot Down function will not operate.

If the Foot position sensor detects that the foot section has reached its lower limit, the Foot Down function will not operate.

Actuator Motor runs until:

1. Hand / foot control button is released.
2. Foot Down limit switch is tripped.
3. Emergency Stop button** is pressed.
5. Position Sensor malfunction*.
6. Overcurrent protection tripped.
7. Software time-out limit is reached
(approx. 20 seconds).

* Programmable models only.

** Midmark models only.

[This feature is not available on Ritter models]

Operation & Troubleshooting

Foot Up / Down Function - continued

Problem: No Foot Up or Foot Down.

Refer To:	Page
Limit Switches	B-4
Hand & Foot Controls	B-6
Foot Actuator	B-25
Main PC Board	B-40
Wiring Diagrams	D-1
Exploded Views / Part Numbers	E-1

Loose / Damaged Wire Connections
(Hand/Foot Control, Foot Actuator,
& Foot Up/Down Limit Switches)

1st ✓

Foot Actuator

Refer to: Section B - Foot Actuator

3rd ✓

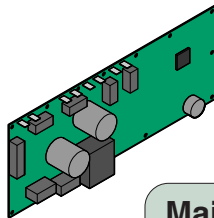
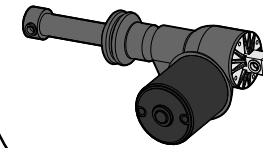

Main PC Board

Refer to: Section B - Main PC Board

4th ✓

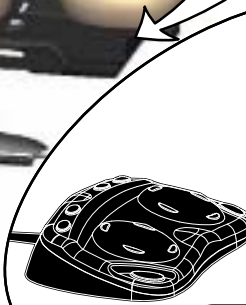

Hand / Foot Control

Refer to: Section B - Hand & Foot Controls

2nd ✓



MA648801i

Foot Up / Down Function - continued

Problem: No Foot Up.
Foot Down - OK.

Refer To:	Page
Limit Switches	B-3
Hand & Foot Controls	B-6
Main PC Board	B-40
Wiring Diagrams	D-1
Exploded Views / Part Numbers	E-1

1st ✓ Pan Limit Switch

Push Treatment Pan all the way in, then try again.
Still no movement? Check Pan Limit Switch

Pan Limit Switch
(later models)

Pan Limit Switch
(older models)

Foot UP Limit Switch
(Ritter models)

2nd ✓ Loose / Damaged Wire Connections

(Hand/Foot Control, Foot Up & Pan Limit Switches)

3rd ✓ Foot Up Limit Switch

Refer to: Section B - Limit Switches

5th ✓ Main PC Board

Refer to: Section B - Main PC Board

Foot UP Limit Switch
(Midmark models)

4th ✓ Hand / Foot Control

Refer to: Section B - Hand & Foot Controls

MA648903i

Models:
Serial Numbers:

ALL

Foot Up / Down

Operation & Troubleshooting

Refer To:	Page
Limit Switches	B-3
Hand & Foot Controls	B-6
Main PC Board	B-40
Wiring Diagrams	D-1
Exploded Views / Part Numbers	E-1

Foot Up / Down Function - continued

Problem: No Foot Down.
Foot Up - OK.

Loose / Damaged Wire Connections 1st ✓
(Hand/Foot Control, Foot Down Limit Switch)

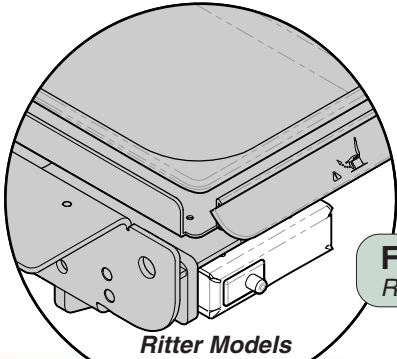

Foot Down Limit Switch 2nd ✓
Refer to: Section B - Limit Switches

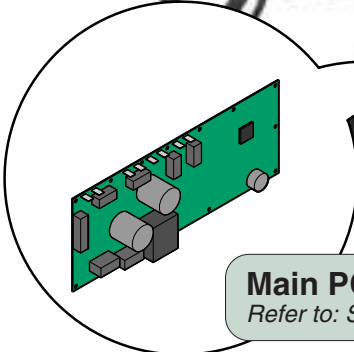
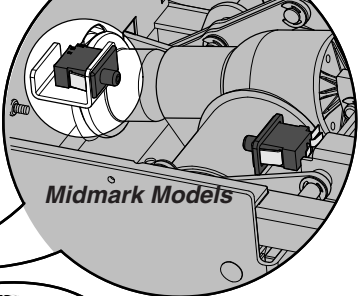

Main PC Board 4th ✓
Refer to: Section B - Main PC Board

MA649001i



Hand / Foot Control 3rd ✓
Refer to: Section B - Hand & Foot Controls

Foot Up / Down Function - continued

Problem: Foot drifts down.

Refer To:	Page
Foot Actuator	B-25
Wiring Diagrams	D-1
Exploded Views / Part Numbers	E-1



Foot Actuator

Refer to: Section B - Foot Actuator

1st ✓

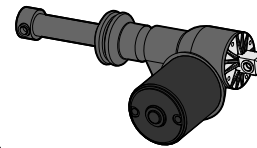

Models:
Serial Numbers:

ALL

Foot Up / Down

Operation & Troubleshooting

Refer To:	Page
Foot Actuator	B-25
Wiring Diagrams	D-1
Exploded Views / Part Numbers	E-1

Foot Up / Down Function - continued

Problem: Noisy operation.
(Grinding, squeaking, etc)



Operation & Troubleshooting

Foot Up / Down Function - continued

Problem: Moves slowly - *and/or*
Will not lift patient.

Refer To:	Page
General Information (<i>Specifications</i>).....	ii
Foot Actuator	B-25
Wiring Diagrams	D-1
Exploded Views / Part Numbers	E-1

1st ✓ Did patient exceed 450 lb. weight limit?

Inform staff that max. patient weight is 450 lbs.

Refer to: General Information Section

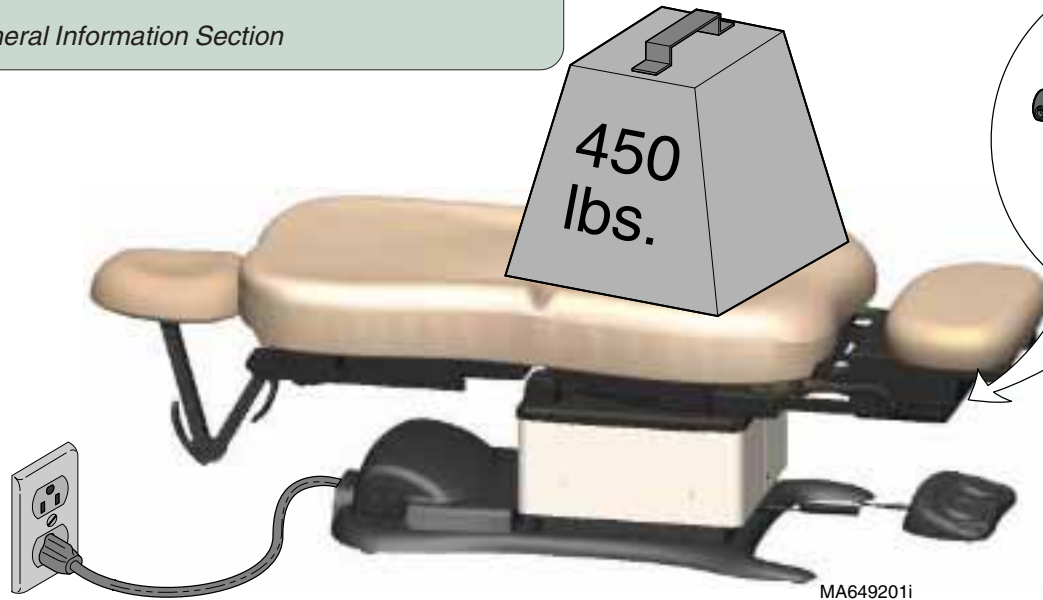

3rd ✓ Foot Actuator

Refer to: Section B - Foot Actuator

2nd ✓ Low voltage to table

Required voltage:

115 VAC setting 115 ±10% VAC

230 VAC setting 230 ±10% VAC

Models:
Serial Numbers:

ALL

Foot Up / Down

A-45

Operation & Troubleshooting

Foot Up / Down Function - continued

Problem: Foot Up *and/or* Foot Down moves briefly, then stops ("beeps").

Refer To:	Page
Foot Actuator	B-25
Position Sensors	B-32
Main PC Board	B-40
Wiring Diagrams	D-1
Exploded Views / Part Numbers	E-1

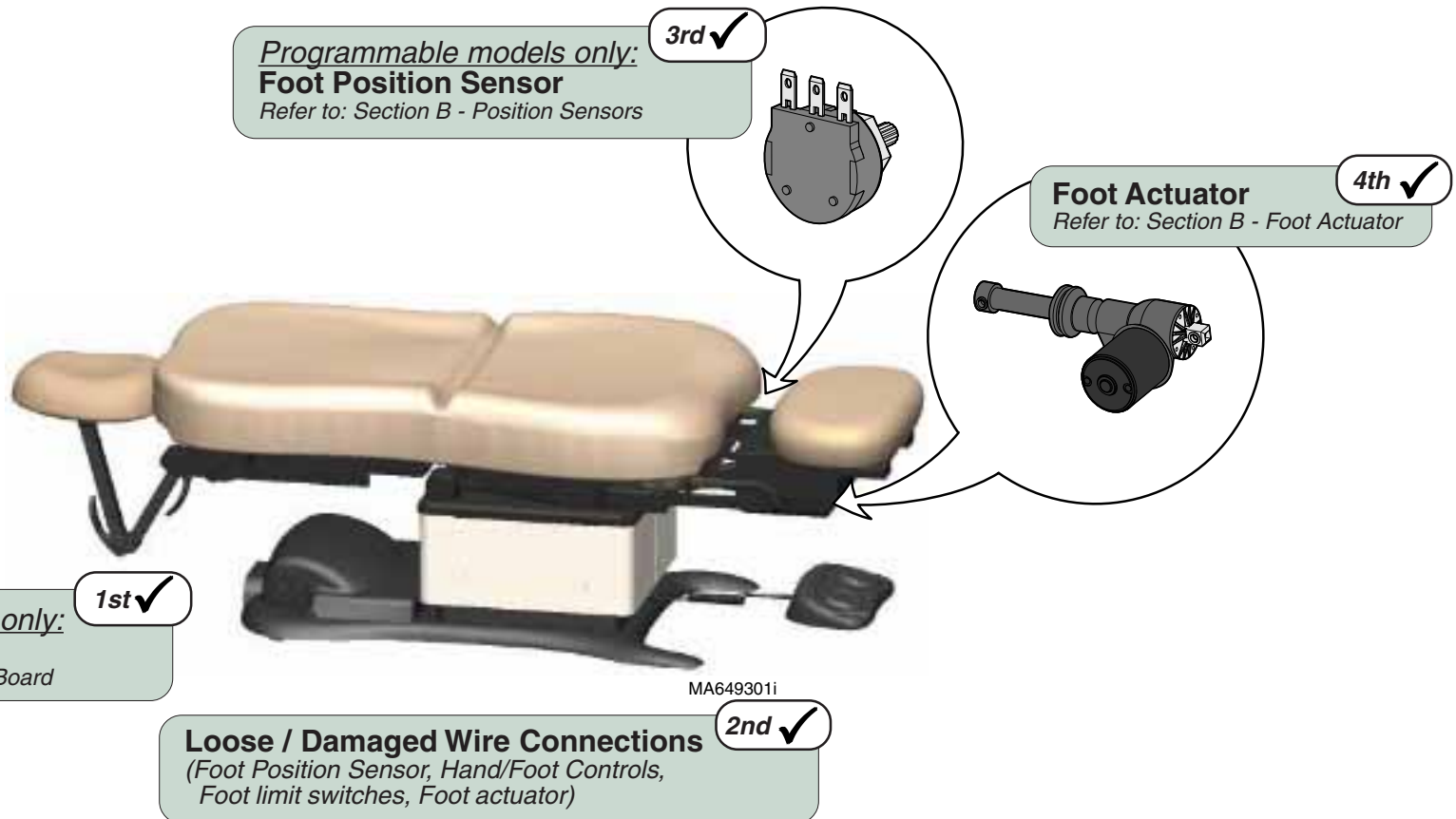

This page intentionally blank.

Operation & Troubleshooting

Crash Avoidance System

The Crash Avoidance System disables the *Base Down*, *Back Down*, and *Tilt Up* functions if a potential crash position is detected.

This illustration shows only the components that are monitored by the Crash Avoidance System. Refer to the following page for a detailed description of "crash" position and how the system functions.

Troubleshooting [Crash Avoidance System]

Problem	Page
No Base Down, Back Down, Tilt Up [Table is NOT in "Crash Position"]	A-50
Headrest Collides w/Floor	A-51

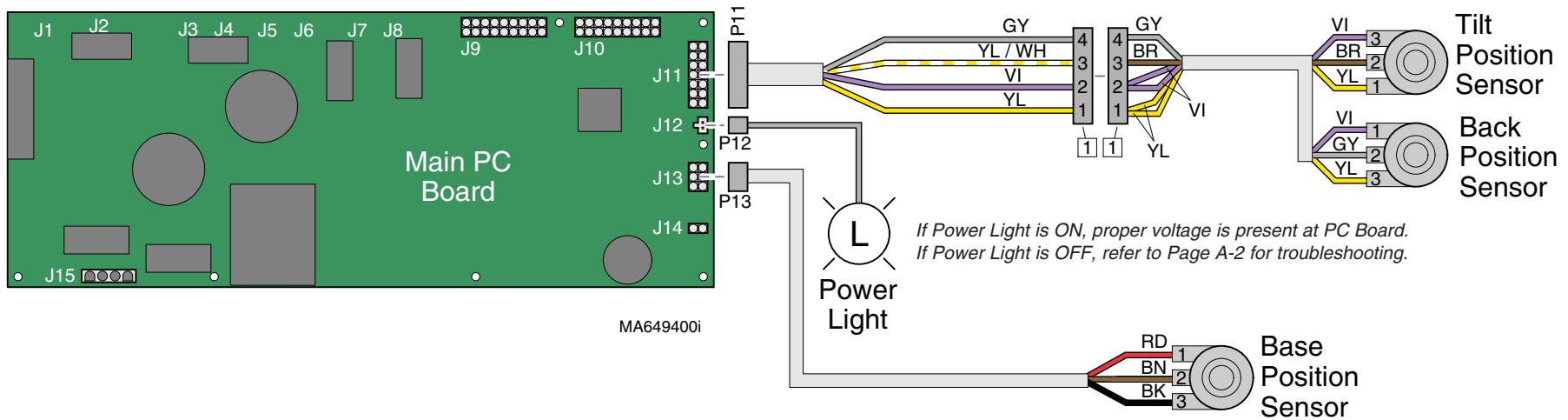

Crash Avoidance System

When Are Functions Disabled?

The Base, Back, and Tilt position sensors continuously monitor the position of each axis (*Base, Back, Tilt*). This information is transmitted to the PC Board.

Based on the position sensors readings, circuitry on the PC Board estimates the position of the headrest mechanism. If a potential crash position is detected, the *Base Down*, *Back Down*, and *Tilt Up* functions are disabled.

When Are Functions Restored?

Functionality is restored when one or more of the axis (*Base, Back, and/or Tilt*) are moved out of the potential crash position.

What Is Crash Position?

The chair is considered to be in a potential crash position when the Base, Back, and Tilt position sensors indicate that the headrest mechanism is approximately 2 in. (5 cm) from the floor*.

* This measurement is an estimate based on "normal" headrest position (shown). The distance from the floor will vary with different headrest positions.

Example: Chair in Crash Position

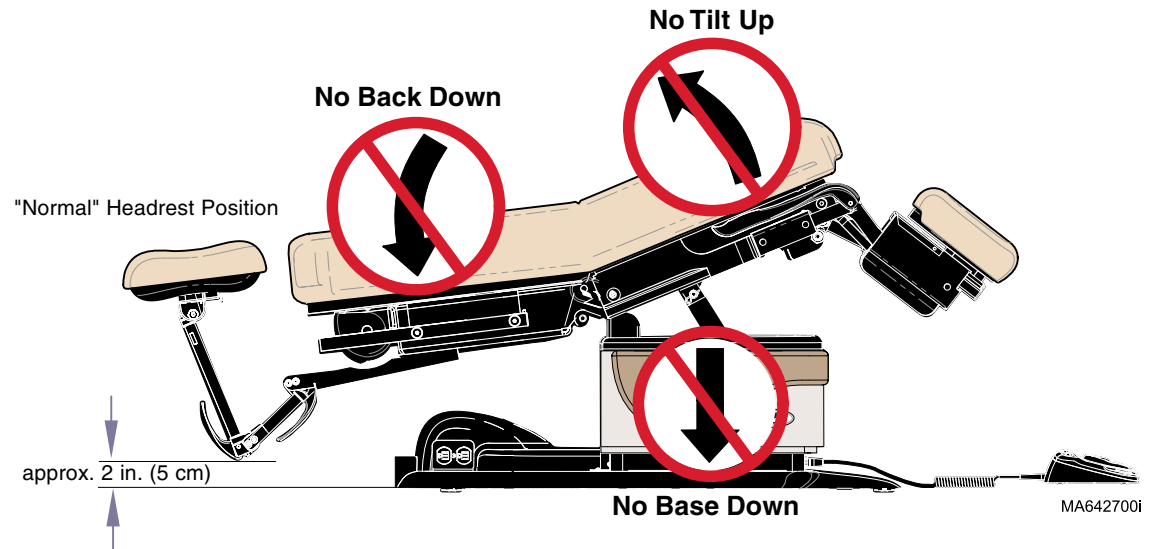

Models:
Serial Numbers:

630 (all)
all

75 (-020/-021)
all

**Crash Avoidance
System**

Operation & Troubleshooting

Crash Avoidance System - continued

Problem: No Base Down, Back Down, Tilt Up functions.
- and - Table is not in "Crash Position"

Refer To:	Page
Position Sensors	B-32
Main PC Board	B-40
Wiring Diagrams	D-1
Exploded Views / Part Numbers	E-1

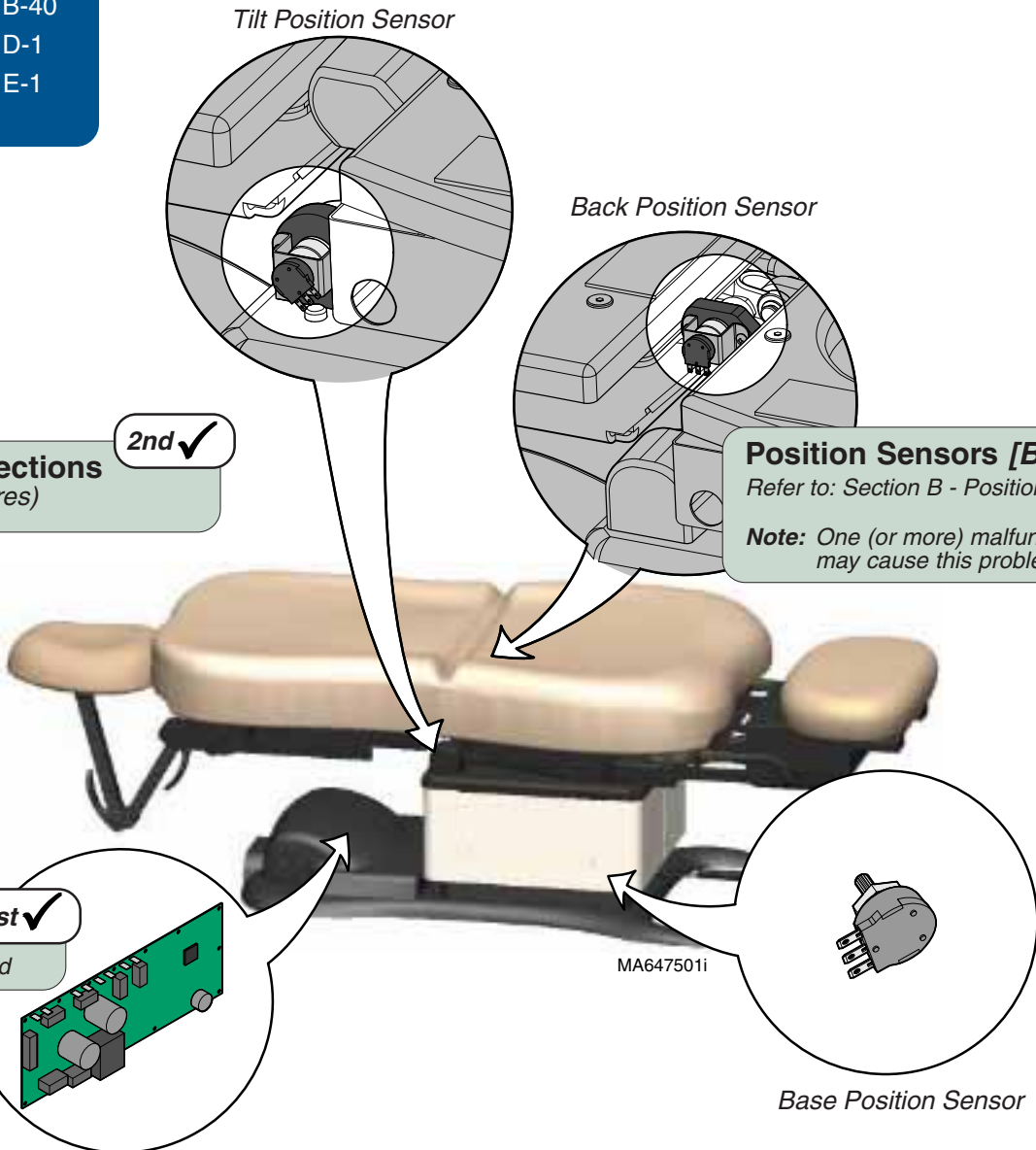

Loose / Damaged Wire Connections 2nd ✓
(Base / Tilt / Back Position Sensor wires)

Position Sensors [Base / Back / Tilt] 3rd ✓
Refer to: Section B - Position Sensors
Note: One (or more) malfunctioning sensor may cause this problem to occur.

Calibrate PC Board 1st ✓
Refer to: Section B - Main PC Board

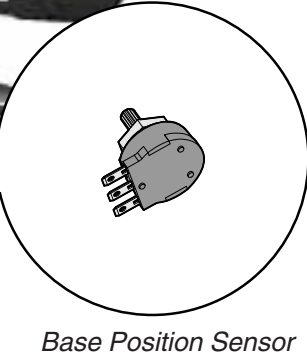
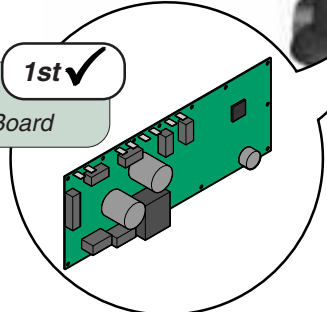

Models:	630 (all)	75 (-020/-021)
Serial Numbers:	all	all

Crash Avoidance System - continued

Problem: Headrest collides with floor.

Refer To:	Page
Position Sensors	B-32
Main PC Board	B-40
Wiring Diagrams	D-1
Exploded Views / Part Numbers	E-1

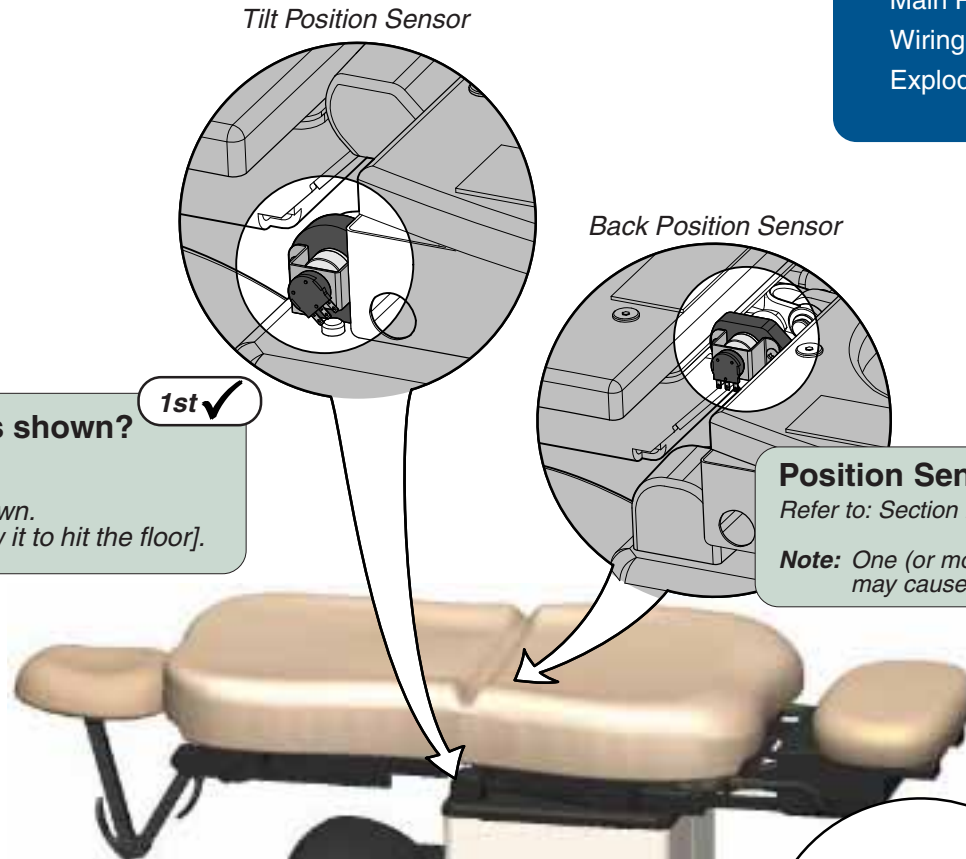

1st ✓
Is the headrest positioned as shown?
 If YES, go to next check.
 If NO, reposition the headrest as shown.
 [Certain headrest positions may allow it to hit the floor].

3rd ✓
Position Sensors [Base / Back / Tilt]
 Refer to: Section B - Position Sensors
Note: One (or more) malfunctioning sensor may cause this problem to occur.

2nd ✓
Calibrate PC Board
 Refer to: Section B - Main PC Board

Models:
Serial Numbers:

630 (all)
 all

75 (-020/-021)
 all

Crash Avoidance System

Operation & Troubleshooting

Position Programming

The programming feature allows the user to store up to four frequently used table positions.

This illustration shows only the components that affect the position programming. Refer to the following page for a detailed description of this feature.

Troubleshooting [Position Programming]

Problem	Page
Positions cannot be programmed	A-54
When Position Button (1,2,3,4) is pressed: Table does not move	A-54
Table moves to wrong position	A-54

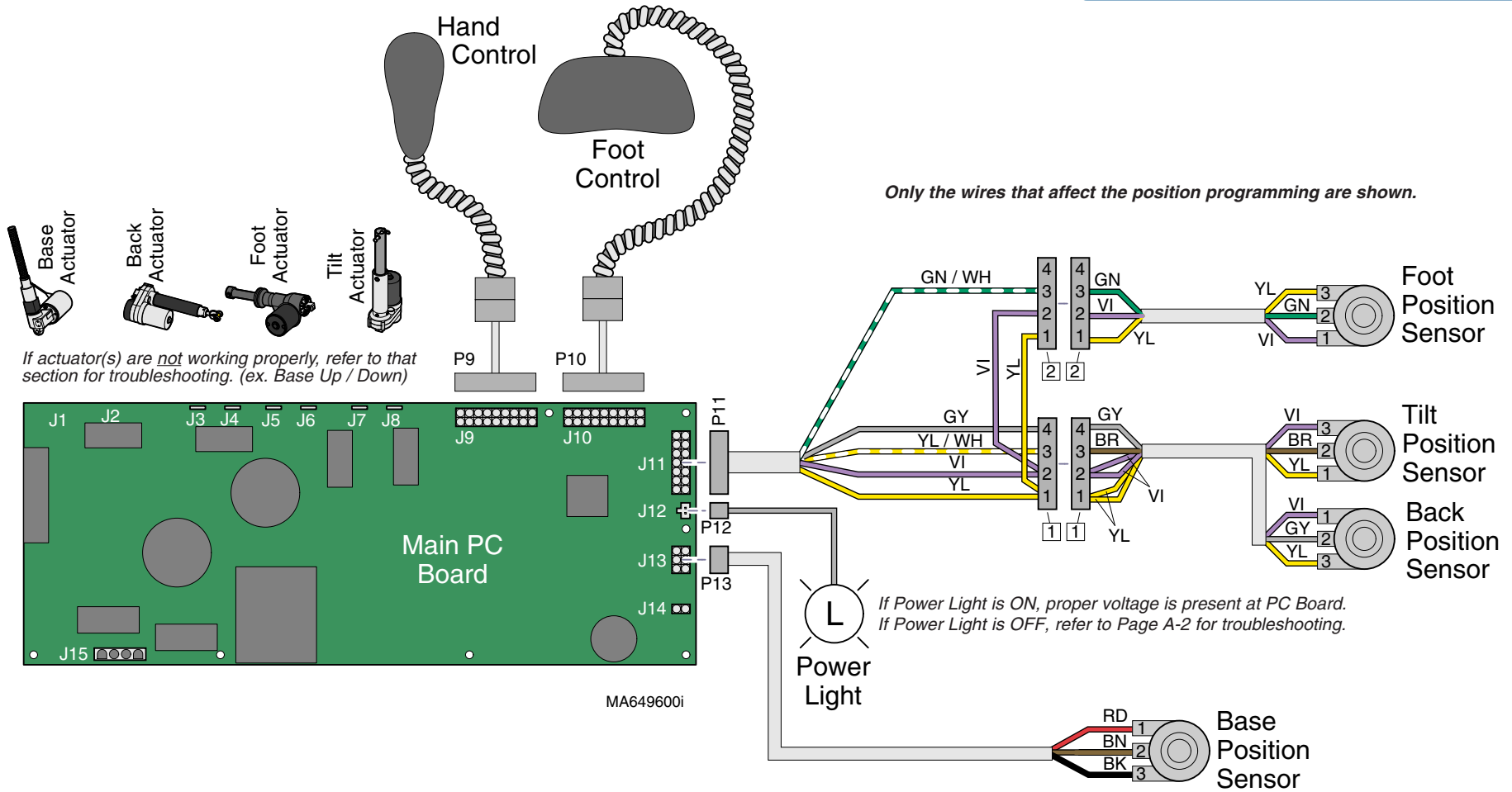

Position Programming

Programming a Table Position

The four position sensors continuously monitor the position of each axis (*Base, Back, Tilt, Foot*). This information is transmitted to the PC Board.

When a table position is properly programmed into the PC board's memory, the position of each axis is recorded based on the readings from the four sensors.

Recalling a Programmed Position

When a programmed position is recalled, the PC board activates the required functions (*all at the same time*) until the readings from the four position sensors match those of the recorded position.

To program a table position....

- A. Move the table to desired position.
- B. Press the Program button. (you will hear a single "beep")
- C. Press the desired Position button (1, 2, 3, or 4). (three "beeps")

Tip: You must press the Position button within 5 seconds of pressing the Program button.



To recall a programmed position....

Press and hold the desired Position button (1, 2, 3, or 4).

Models:
Serial Numbers:

630 (-002 & -004)
all

75 (-021)
all

Position Programming

© Midmark Corporation 2005 SF-1838

Operation & Troubleshooting

Refer To:	Page
Hand & Foot Controls	B-6
Main PC Board	B-40
Wiring Diagrams	D-1
Exploded Views / Part Numbers	E-1

Position Programming - continued

Problem: Positions cannot be programmed. - or
When position button is pressed, table does not move,
or moves to wrong position.

[All manual functions - OK]

Note: If manual function(s) are not working properly, refer to that section for troubleshooting. (ex. Base Up / Down)

Reprogram the desired position. (see previous page)

Did you hear all of the "beeps" indicated in the programming procedure?

If NO, go to **2nd** ✓

If YES, go to **3rd** ✓

1st ✓

Calibrate PC Board

Refer to: Section B - Main PC Board

3rd ✓

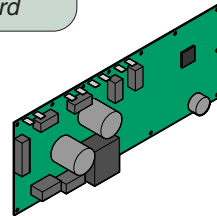

Main PC Board

Refer to: Section B - Main PC Board

4th ✓

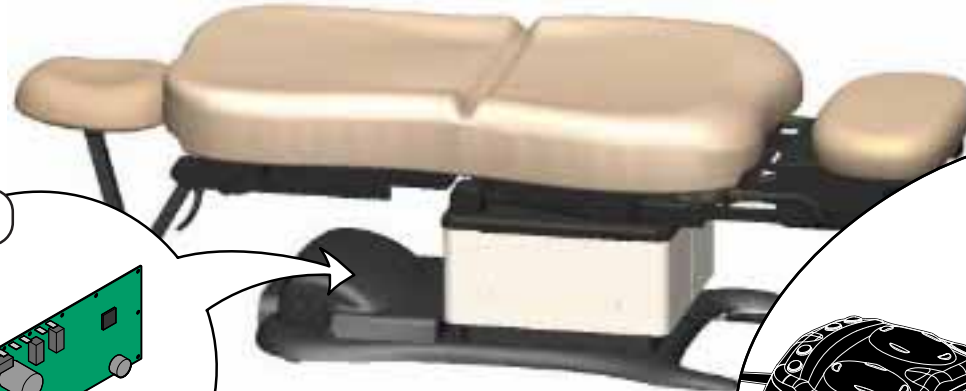

MA649701i

Hand / Foot Controls

Refer to: Section B - Hand & Foot Controls.

2nd ✓

This page intentionally blank.

Operation & Troubleshooting

"Home" Function

The Home function automatically lowers the table base to **Home Position "A"** [23 in. (58.4 cm)] or **Home Position "B"** [19 in. (48.2 cm)].

This illustration shows only the components that affect the Home Function. Refer to the following page for a detailed description of this feature.

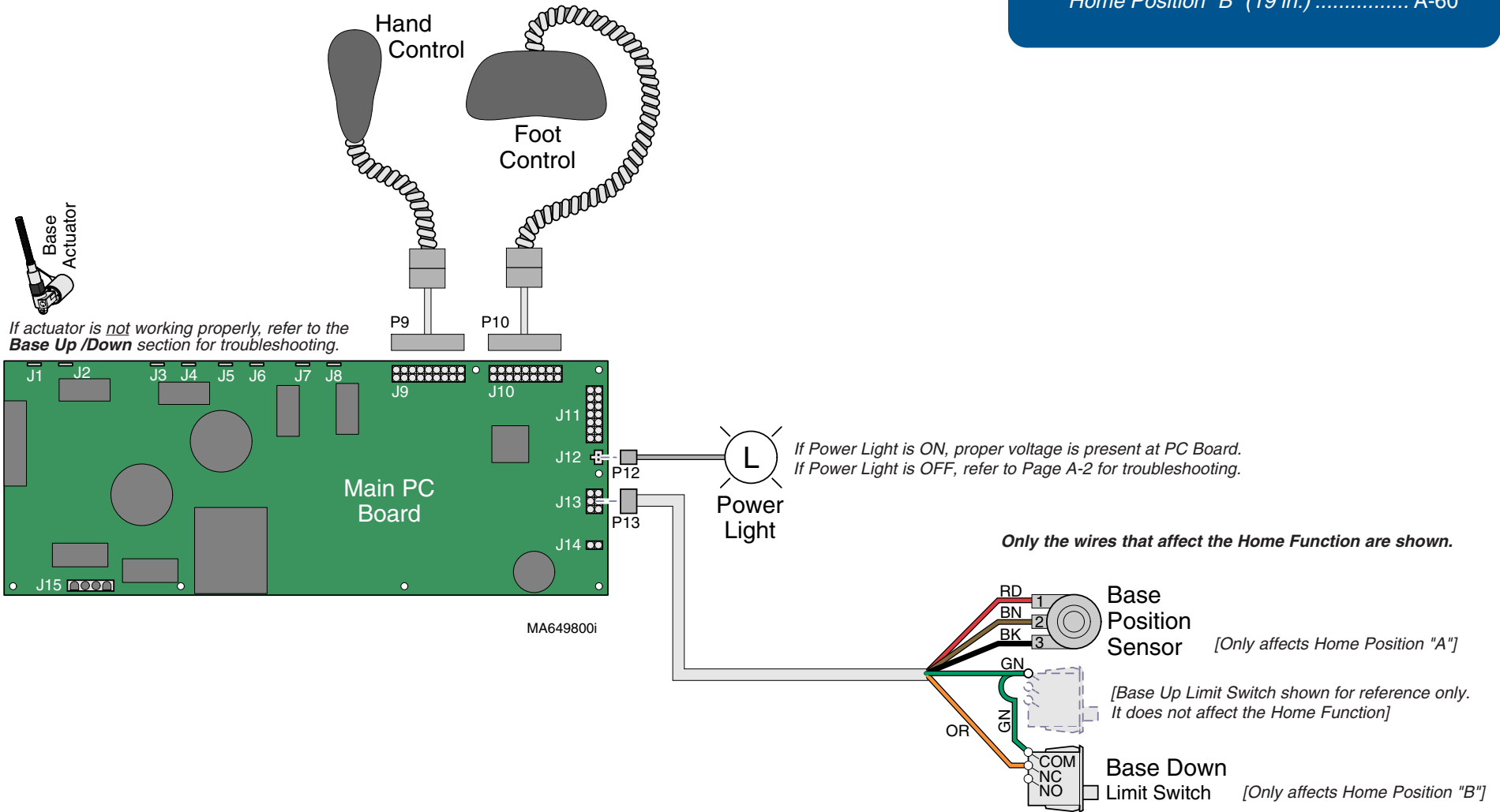

Troubleshooting

["Home" Function]

Problem	Page
When Home button is pressed, nothing happens	A-58
Table does not stop at correct height:	
Home Position "A" (23 in.)	A-59
Home Position "B" (19 in.)	A-60

"Home" Function

Home Position "A" [23 in. (58.4 cm)]

When the Home button is pressed then immediately released, the Base Down function is activated.

The Base Position Sensor monitors the height of the table as it lowers. This information is transmitted to the PC Board.

When the Base Position Sensor indicates that table has reached 23 in., the PC Board stops the table.

Home Position "B" [19 in. (48.2 cm)]

When the Home button is pressed and held for approximately 2 seconds a short "beep" is emitted, and the Base Down function is activated.

The table stops when the Base Down Limit Switch is tripped at approx. 19 in.

*To go to Home Position "A" [23 in. (58.4 cm)]....
Press, then immediately release the Home button.*



*To go to Home Position "B" [19 in. (48.2 cm)]...
Press and hold the Home button until you hear a single "beep"
(approx. 2 seconds).*

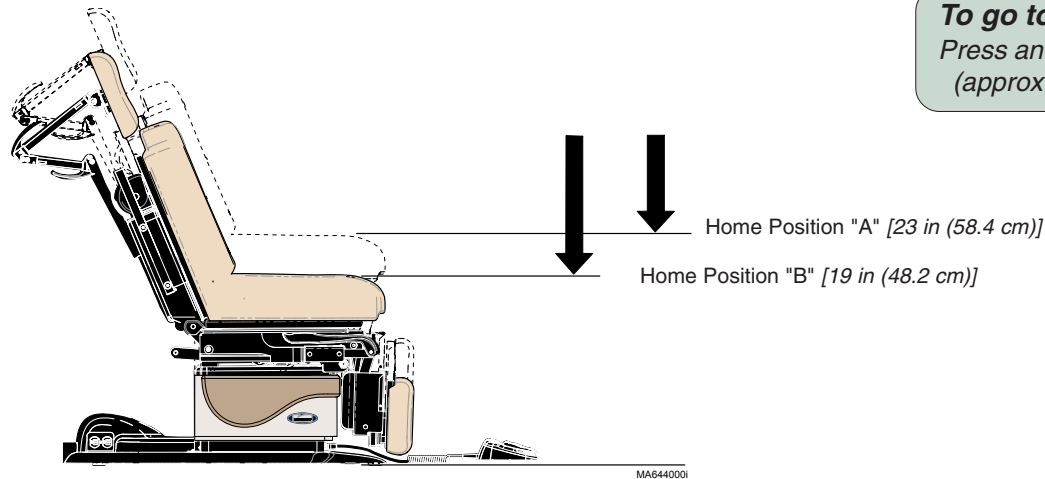

Models:
Serial Numbers:

630 (all)
all

75 (-020/-021)
all

"Home" Function

Operation & Troubleshooting

<u>Refer To:</u>	<u>Page</u>
Hand & Foot Controls	B-6
Main PC Board	B-40
Wiring Diagrams	D-1
Exploded Views / Part Numbers	E-1

"Home" Function - continued

Problem: When Home button is pressed, nothing happens.

[All manual functions - OK]

Note: If manual function(s) are not working properly, refer to that section for troubleshooting. (ex. Base Up / Down)

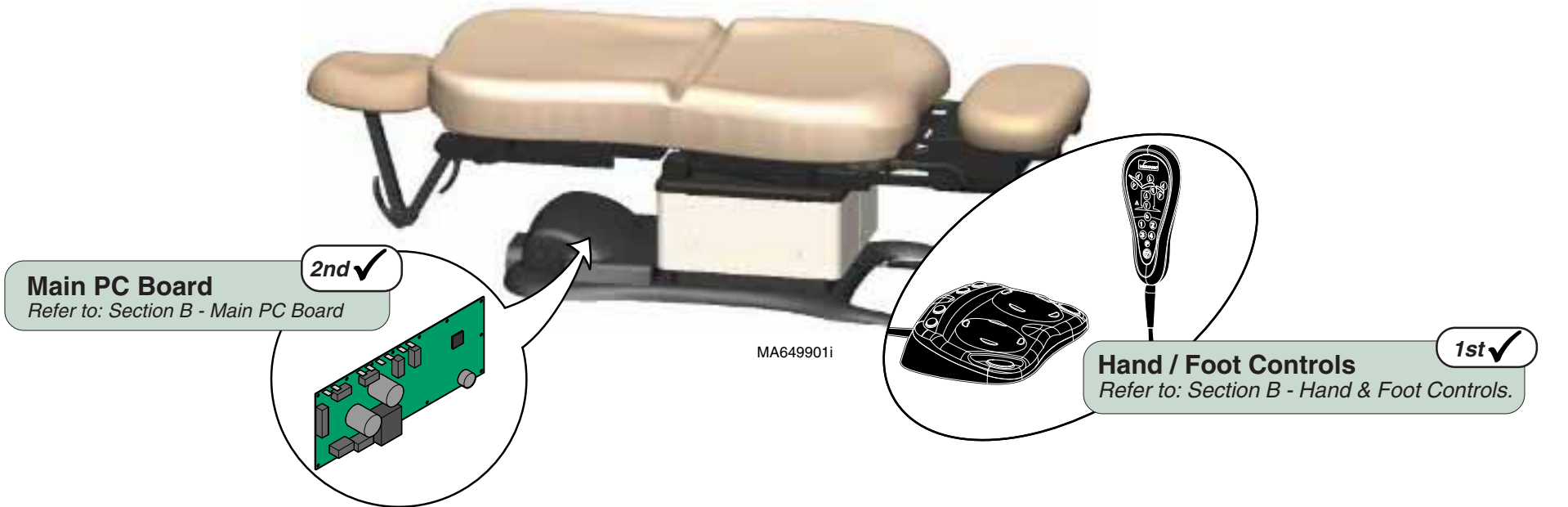

"Home" Function - continued

Problem: Home position "A" does not stop at 23 in. (58 cm).
Home position "B" - OK.

[All manual functions - OK]

Note: If manual function(s) are not working properly, refer to that section for troubleshooting. (ex. Base Up / Down)

Refer To:	Page
Position Sensors	B-32
Main PC Board	B-40
Wiring Diagrams	D-1
Exploded Views / Part Numbers	E-1

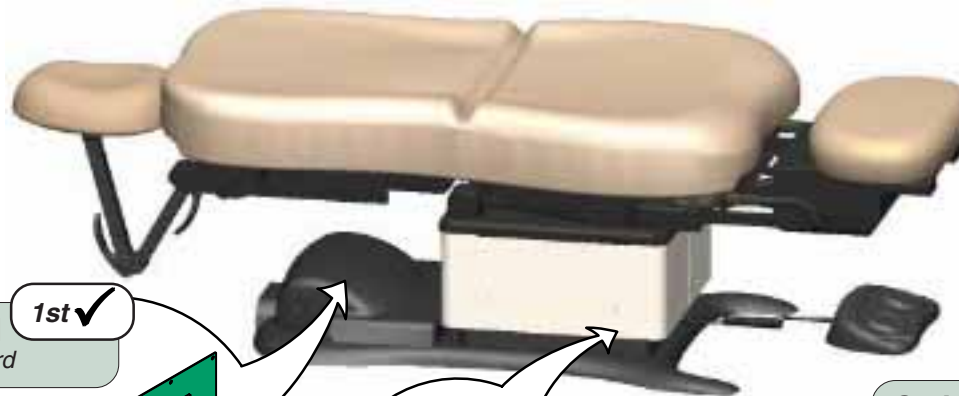

Calibrate Main PC Board

Refer to: Section B - Main PC Board

1st ✓

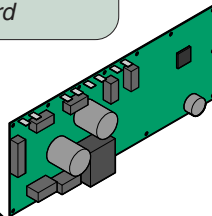

Calibrate Main PC Board

Refer to: Section B - Main PC Board

1st ✓

Base Position Sensor

Refer to: Section B - Position Sensors

2nd ✓

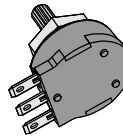

MA650001i

Models:
Serial Numbers:

630 (all)
all

75 (-020/-021)
all

"Home" Function

Operation & Troubleshooting

Refer To:	Page
Limit Switches	B-3
Wiring Diagrams	D-1
Exploded Views / Part Numbers	E-1

"Home" Function - continued

Problem: Home position "B" does not stop at 19 in. (48 cm).
Home position "A" - OK.

[All manual functions - OK]

Note: If manual function(s) are not working properly,
refer to that section for troubleshooting.
(ex. Base Up / Down)

Loose / Damaged Wire Connections
(Base Down Limit Switch)

1st ✓

Base Down Limit Switch

Refer to: Section B - Limit Switches

2nd ✓

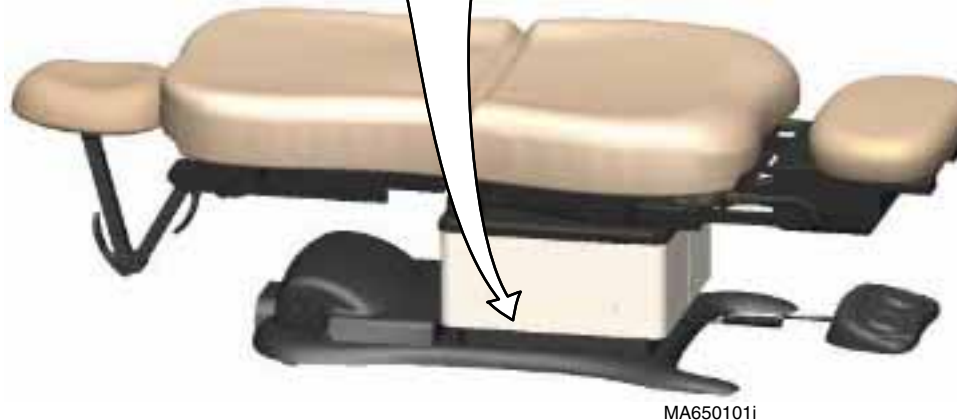

This page intentionally blank.

Operation & Troubleshooting

Quick Chair™ Function (w/ Foot Control Only)

This function activates the *Base Down*, *Tilt Down*, *Foot Down*, and *Back Up* functions at the same time to move the table into "chair position".

This illustration shows only the components that affect the Quick Chair™ Function. Refer to the following page for a detailed description of this feature.

Troubleshooting [Quick Chair™ Function]

Problem	Page
When Quick Chair button is pressed & held, the table does not move	A-64

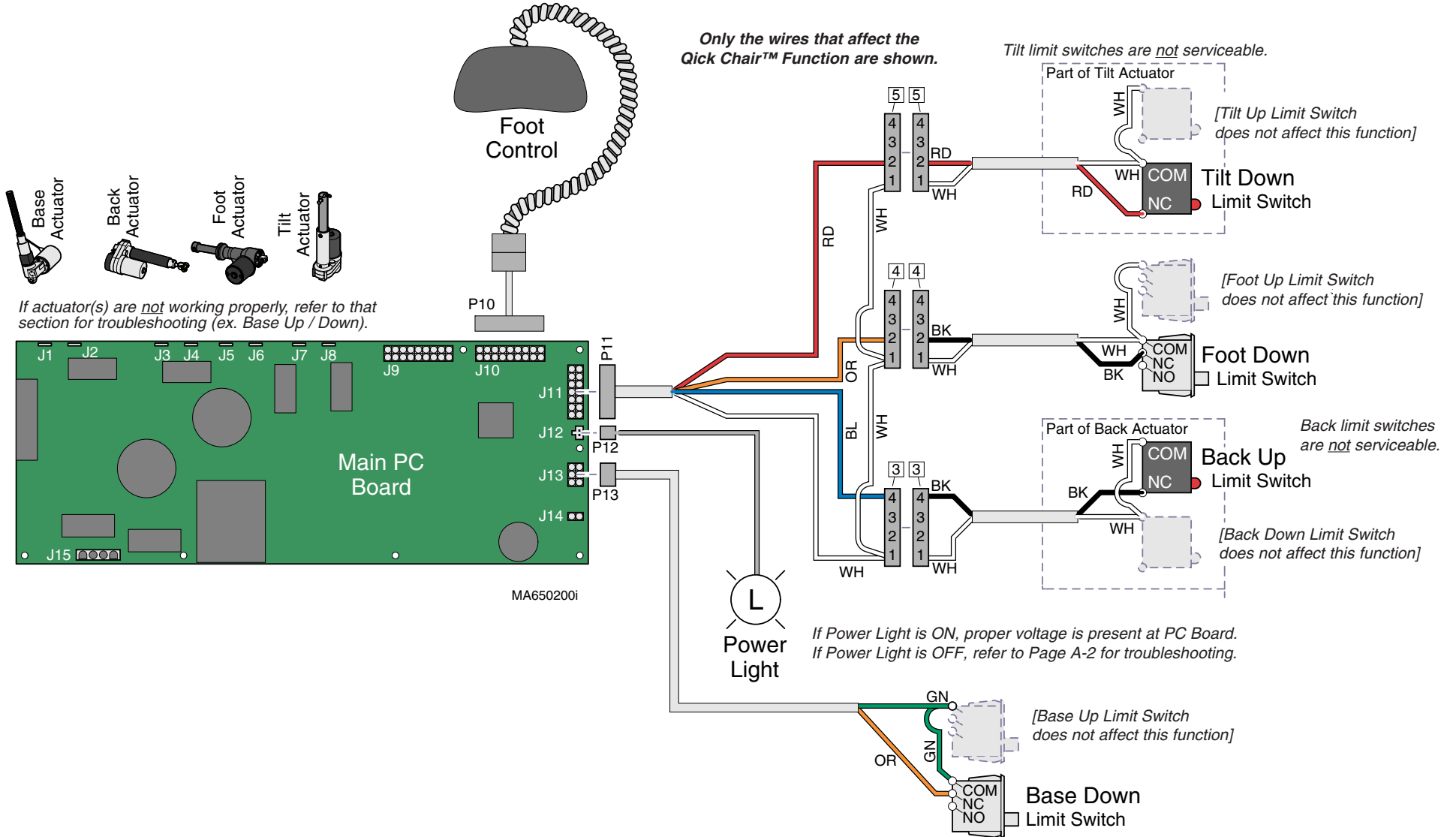

Quick Chair™ Function

What is "Chair Position"?

Base: *all the way down*
 Back: *all the way up*
 Tilt: *all the way down*
 Foot: *all the way down*

How it works...

When the Quick Chair™ button is pressed and held, the PC Board activates all of the following functions:

<u>Function</u>	<u>Runs until...</u>
Base Down	Base Down limit switch is tripped
Back Up	Back Up limit switch is tripped
Tilt Down	Tilt Down limit switch is tripped
Foot Down	Foot Down limit switch is tripped



Quick Chair™
Button

To activate the Quick Chair™ function....
 Press and hold the Chair Position button.

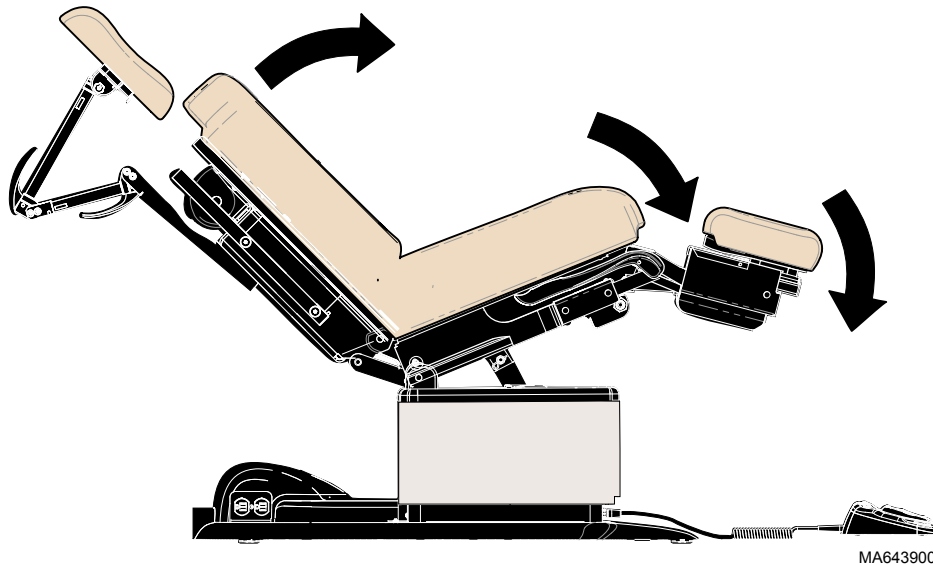

MA643900i

Models:	630 (all)	75 (-020/-021)	
Serial Numbers:	all	all <small>(w/optional foot control)</small>	

**Quick Chair™
Function**

Operation & Troubleshooting

Refer To:	Page
Hand Foot Controls	B-6
Main PC Board	B-40
Wiring Diagrams	D-1
Exploded Views / Part Numbers	E-1

Quick Chair™ Function - continued

Problem: When Quick Chair™ button is pressed & held, the table does not move.

[All manual functions - OK]

Note: If manual function(s) are not working properly, refer to that section for troubleshooting. (ex. Base Up / Down)

Is table already in Chair Position? **1st ✓**

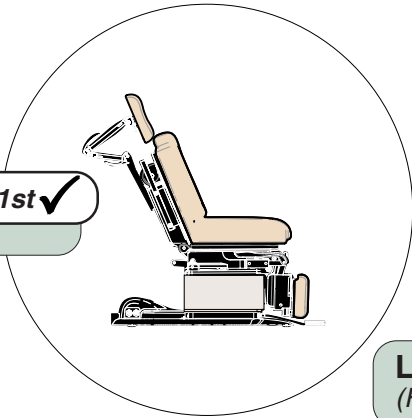

Loose / Damaged Wire Connections **2nd ✓**
(Foot control to PC Board)

Main PC Board **4th ✓**
Refer to: Section B - Main PC Board

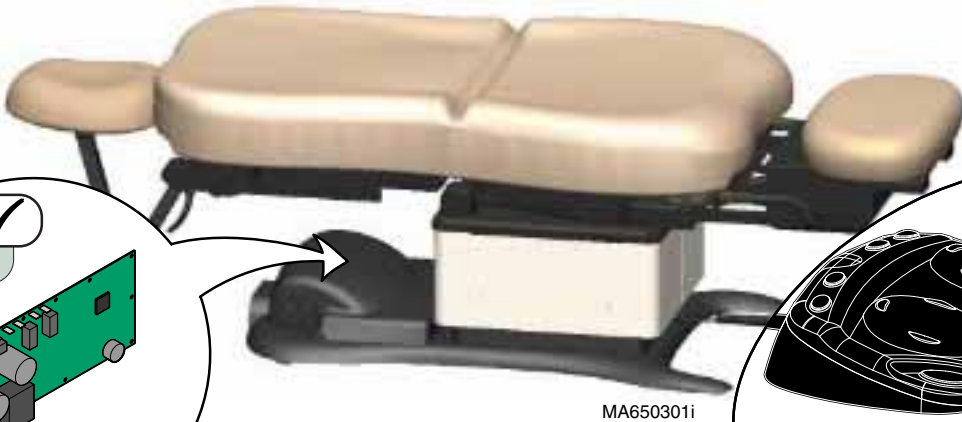
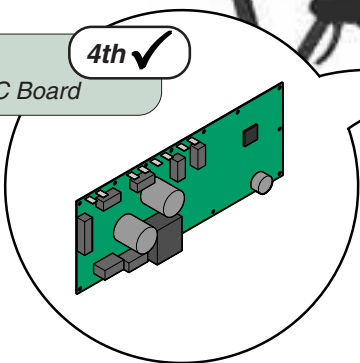

Foot Control **3rd ✓**
Refer to: Section B - Hand & Foot Controls

This page intentionally blank.

Operation & Troubleshooting

Table Receptacles (optional - 115 VAC models only)

This illustration shows only the components that affect the table receptacle.

Only the wires that affect the table receptacles are shown.

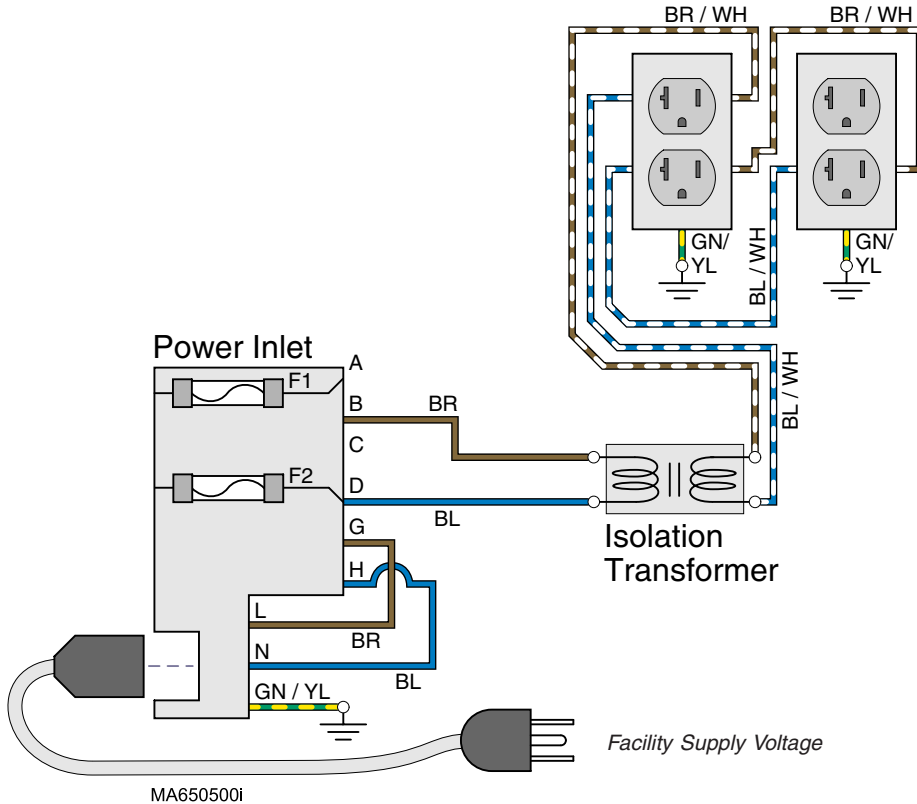

Troubleshooting [Table Receptacles]

Problem	Page
No power at receptacles	A-67

Facility Supply Voltage

With the table's power cord properly connected, facility supply voltage (115 VAC) is supplied thru the cord to the power inlet.

Power Inlet



EQUIPMENT ALERT

The voltage setting displayed in the power inlet window must match facility supply voltage (115 VAC).
[Remove fuse holder and rotate 180° to change voltage setting].

Current flows thru two fuses in the power inlet, to the isolation transformer.

Isolation Transformer

NOTE

The isolation transformer separates the receptacles from the rest of the table's electrical system. This transformer is protected from overload by a thermal cutout feature. It will automatically reset when the transformer cools.

The isolation transformer provides 115 VAC to each of the table receptacles.

Table Receptacles - continued

Problem: No power at receptacle(s).

Refer To:	Page
Isolation Transformer / Table Receptacle	B-29
Wiring Diagrams	D-1
Exploded Views / Part Numbers	E-1

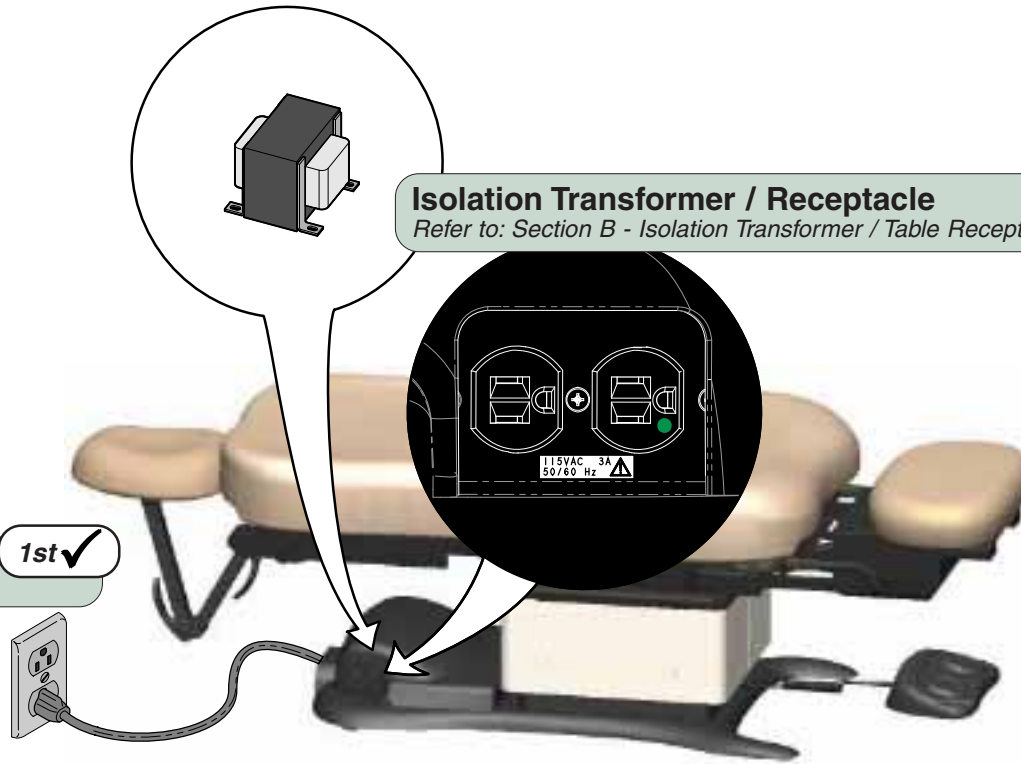

Isolation Transformer / Receptacle

Refer to: Section B - Isolation Transformer / Table Receptacle

3rd ✓

Is there power to the table?

1st ✓

Loose / Damaged Wire Connections
(between power inlet & receptacles)

2nd ✓

MA650601i

Models:
Serial Numbers:

230 (-002)
all

630 (-003/-004/-008/-009)
all

75 (-020/-021)
all

Table Receptacles

Operation & Troubleshooting

Upholstery Heater System (optional)

This illustration shows only the components that affect the Upholstery Heater System. A detailed description of current flow during this function also appears below.

Upholstery Heater Operation

115 VAC is supplied to the upholstery heater PC board thru the power inlet. Circuitry on the PC board converts 115 VAC to 12 VAC. Fuses F1 and F2 protect the circuit.

When the upholstery heater button on the hand control is pressed, 12 VAC is supplied to the upholstery heater.

Note

A timer on the PC board (initiated when the *uph. heater button is pressed*) automatically turns the heater OFF after 8 hours.

A potentiometer on the upholstery heater PC board allows a service technician to adjust the temperature up to 105° F (41° C).

A thermostat, located in the Back Heating Pad, opens at 131° F (55°C) +/- 10% removing power from both Back and Seat section heating elements.

Upholstery Heater runs until:

1. Upholstery heater button is pressed again.
2. 8 hour time limit is reached.
3. Fuse(s) on upholstery heater PC board opens (blows).

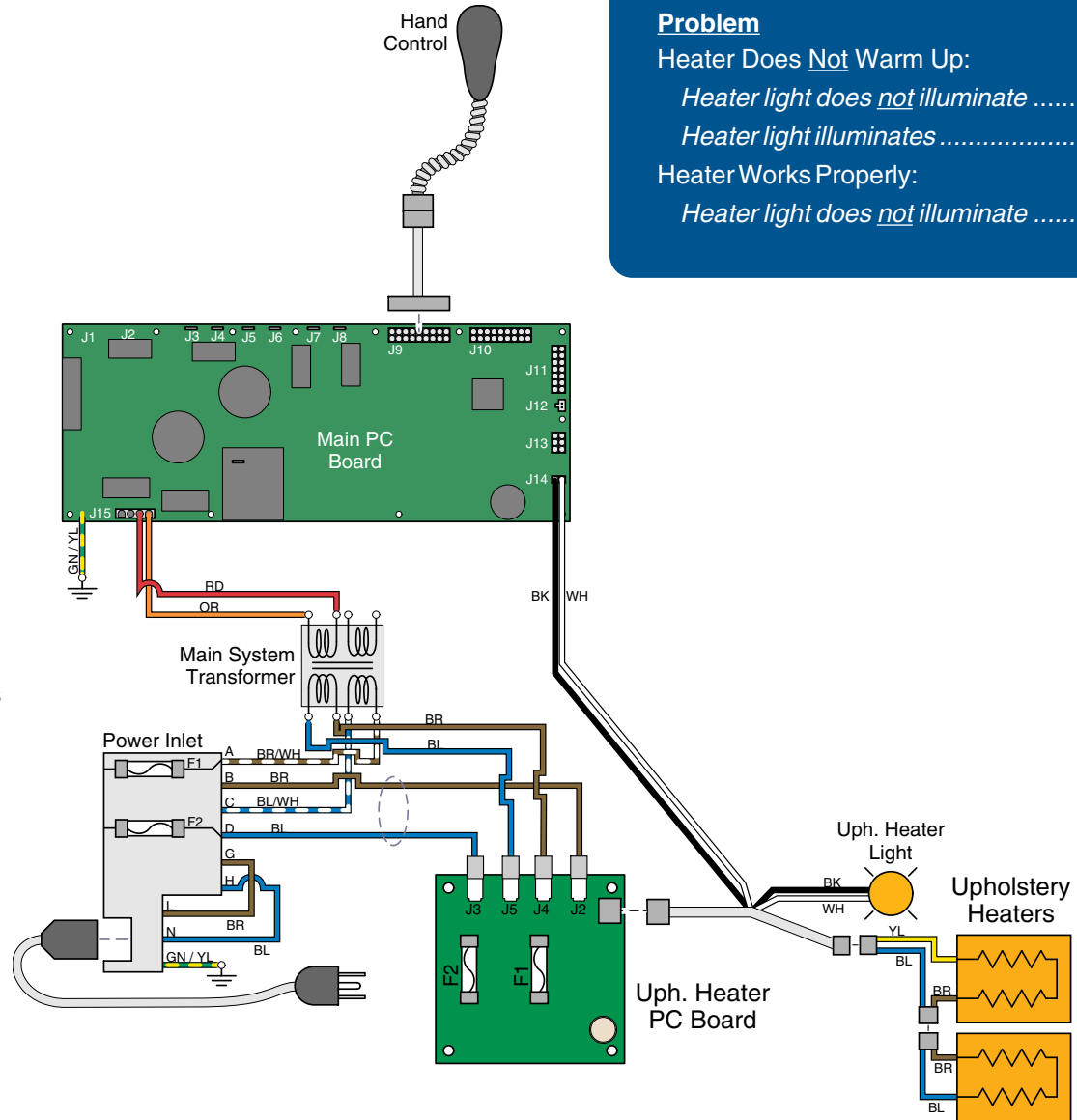

Troubleshooting [Upholstery Heater System]

Problem	Page
Heater Does <u>Not</u> Warm Up:	
Heater light does <u>not</u> illuminate	A-69
Heater light illuminates	A-70
Heater Works Properly:	
Heater light does <u>not</u> illuminate	A-71

MA683600i

Upholstery Heater System - continued

Problem: Heater does not warm up. - and Heater light does not illuminate.

Refer To:	Page
Hand & Foot Controls	B-6
Upholstery Heater System	B-45
Wiring Diagrams	D-1
Exploded Views / Part Numbers	E-1

1st ✓
8-Hour Timer Expired
 Press upholstery heater button to restart heater.

2nd ✓
Loose Wire Connection
 Check uph. heater PCB connections to the following:
 heater light / power inlet / main PCB

4th ✓
Hand Control
 Upholstery heater button malfunctioning.
 Refer to: Section B - Hand & Foot Controls



3rd ✓
Fuse(s)
 Check fuses on upholstery heater PCB.

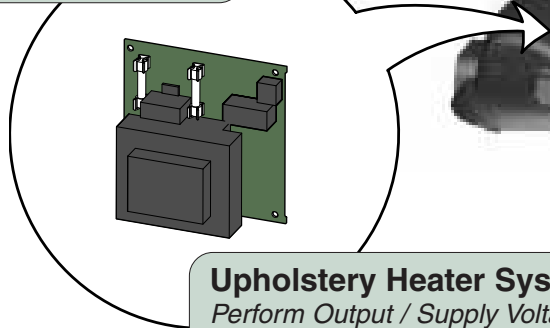

5th ✓
Upholstery Heater System
 Perform Output / Supply Voltage Tests.
 Refer to: Section B - Uph. Heater System



MA6942011

Operation & Troubleshooting

Upholstery Heater System - *continued*

Refer To:

Page

Upholstery Heater System B-45

Wiring Diagrams D-1

Exploded Views / Part Numbers E-1

Problem: Heater does not warm up. - **but**
Heater light does illuminate.

Loose Wire Connection

Check the following connections:
Back & seat section heaters to uph. heater PCB.

1st ✓

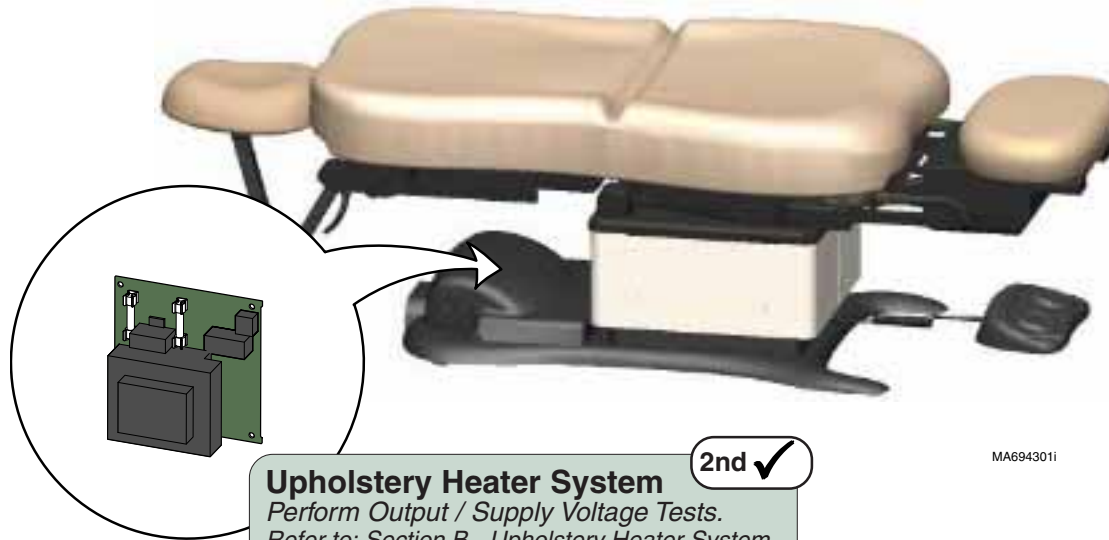

Upholstery Heater System

Perform Output / Supply Voltage Tests.
Refer to: Section B - Upholstery Heater System.

2nd ✓

MA694301i

Operation & Troubleshooting

Upholstery Heater System - continued

Problem: Heater works properly - **but**
Heater light does not illuminate

Refer To:	Page
Upholstery Heater System	B-45
Wiring Diagrams	D-1
Exploded Views / Part Numbers	E-1

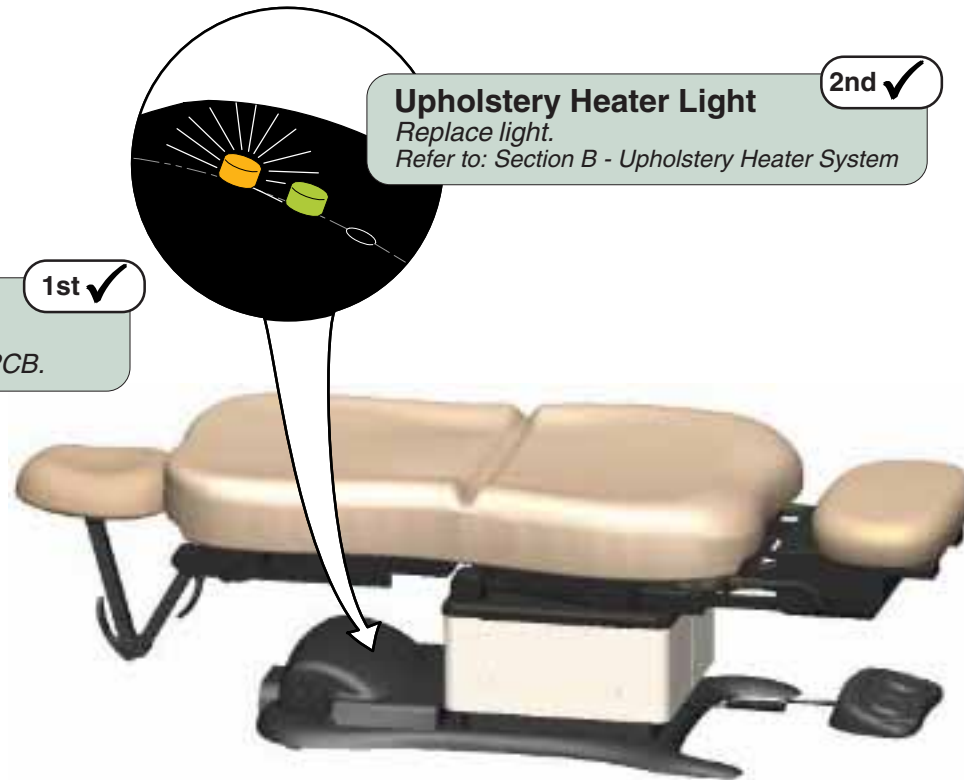

MA694401i

Models: 630 (-007)
Serial Numbers: all

Upholstery Heater

Operation & Troubleshooting

Rotational Base Brake System (optional)

This illustration shows only the components that affect the Rotational Base Brake System. A detailed description of current flow during this function also appears below.

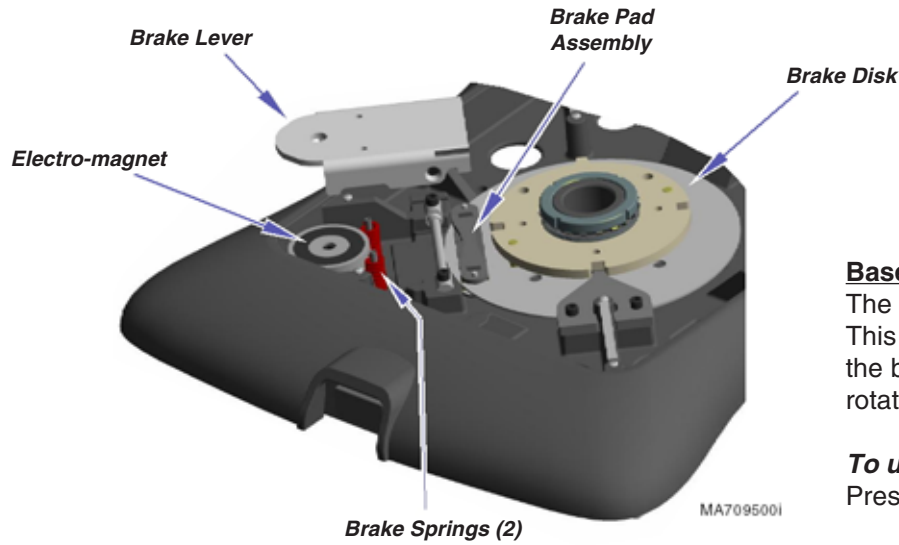

Base Rotation LOCKED:

The two brake springs press upward on the brake lever. This pivots the brake lever so that pressure is applied to the brake pad assembly. This prevents the brake disk from rotating.

To unlock base rotation:

Press & release either brake pedal.

Base Rotation UNLOCKED:

The rotational base PC board supplies 31 - 36 VAC to the two normally closed brake switches. When either brake pedal is pressed & released, the corresponding brake switch opens. When the open switch is detected, the PC board supplies approximately 15 - 20 VAC to the electro-magnet thru the F1 fuse.

When voltage is applied to the electro-magnet, the magnet's pull overpowers the brake springs. This removes pressure from the brake pad assembly allowing the brake disk to rotate.

To lock base rotation:

Press & release either brake pedal.

Note: Base automatically locks in place after 2 minutes.

Troubleshooting

[Rotational Base Brake System]

Problem	Page
Base rotation will not unlock	A-73
Base rotation will not lock	A-74
Base "wobbles" when locked	A-75
Base grinds when rotating	A-75

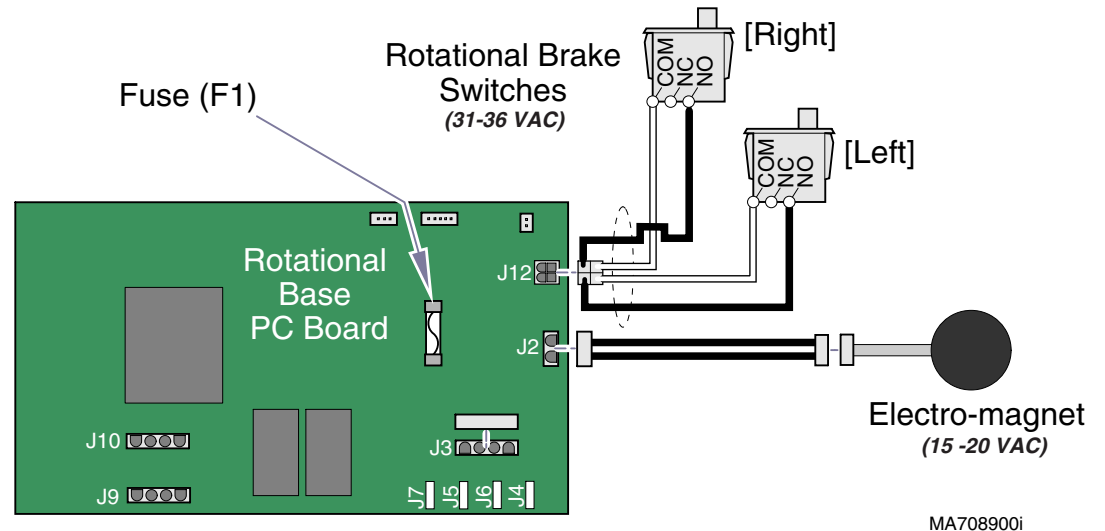

Operation & Troubleshooting

Rotational Base Brake System - continued

Problem: Base rotation will not unlock.

Refer To:	Page
Rotational Base Brake System	B-51
Wiring Diagrams	D-1

Check both brake pedals 1st ✓

If one brake pedal unlocks the base, go to: 2nd ✓

If neither pedal unlocks the base, go to: 3rd ✓

Check Rotational Base PC Board Fuse 5th ✓

If fuse is OK, perform Rotational Brake Electrical Test
Refer to: Section B - Rotational Base Brake System

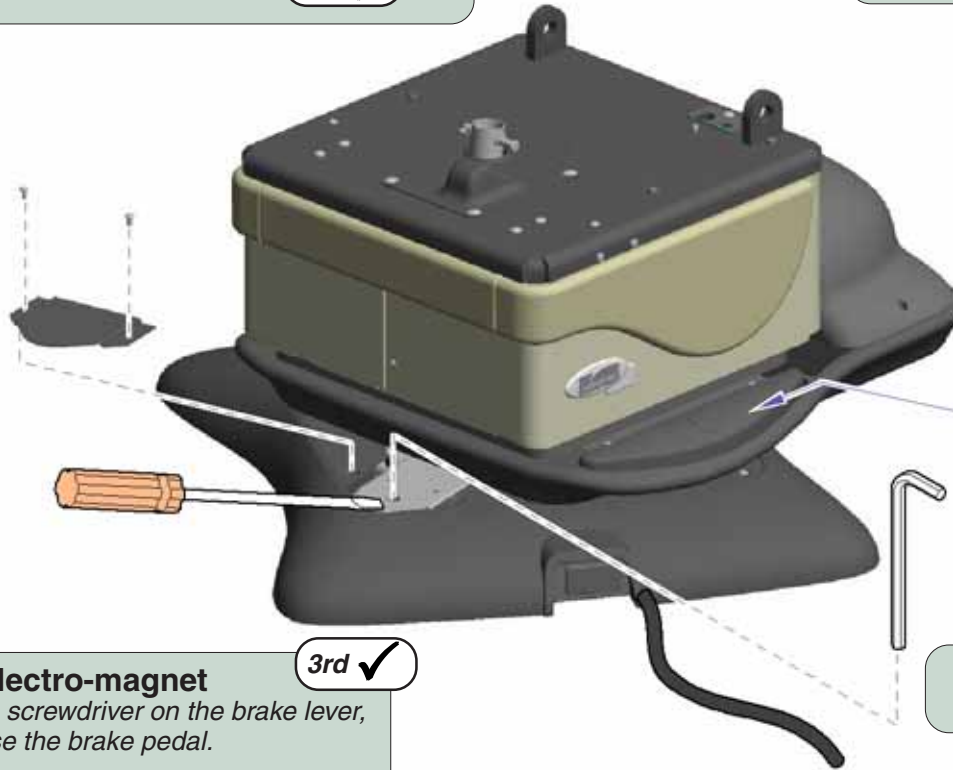

Faulty brake pedal switch 2nd ✓

Check connections / replace switch if necessary.
Refer to: Section B - Rotational Base Brake System

Check the electro-magnet 3rd ✓

While holding a screwdriver on the brake lever, press & release the brake pedal.

Can you feel the electro-magnet energize?

If YES, go to: 4th ✓

If NO, go to: 5th ✓

Perform Magnet Position Adjustment 4th ✓

Refer to: Section B - Rotational Base Brake System

MA709600I

Models:	230 (-003)	630 (-005 & -006)
Serial Numbers:	all	all

**Rotational Base
Brake System**

Operation & Troubleshooting

Rotational Base Brake System - continued

Problem: Base rotation will not lock.

Refer To:	Page
Rotational Base Brake System	B-51
Wiring Diagrams	D-1

Unplug table power cord 1st ✓
If base rotation locks, go to: 2nd ✓
If base does not lock, go to: 3rd ✓

Perform Rotational Brake Electrical Test 2nd ✓
Refer to: Section B - Rotational Base Brake System



Inspect mechanical brake components. 3rd ✓
Refer to: Section B - Rotational Base Brake System
(Brake Lever Removal)

MA709700i

Models:	230 (-003)	630 (-005 & -006)
Serial Numbers:	all	all

Rotational Base Brake System - continued

Problem: Base "wobbles" when locked. - and / or
Base makes grinding noise when rotating

Refer To: **Page**
Rotational Base Brake System B-51
Wiring Diagrams D-1

1st ✓ Debris between upper & lower castings

Without separating the base castings, remove any debris.

2nd ✓ Loose hub screws

Tighten four screws securing the upper & lower castings.

For access instructions refer to:
Section B - Rotational Base Brake System
(Separating Upper & Lower Base Castings)

3rd ✓ Inspect rotation bearings / brake disc

Inspect needle bearing & brake disc for damage, debris, etc.
Lock nut must be tightened to 75 ft/lbs.

For access instructions refer to:
Section B - Rotational Base Brake System
(Separating Upper & Lower Base Castings)

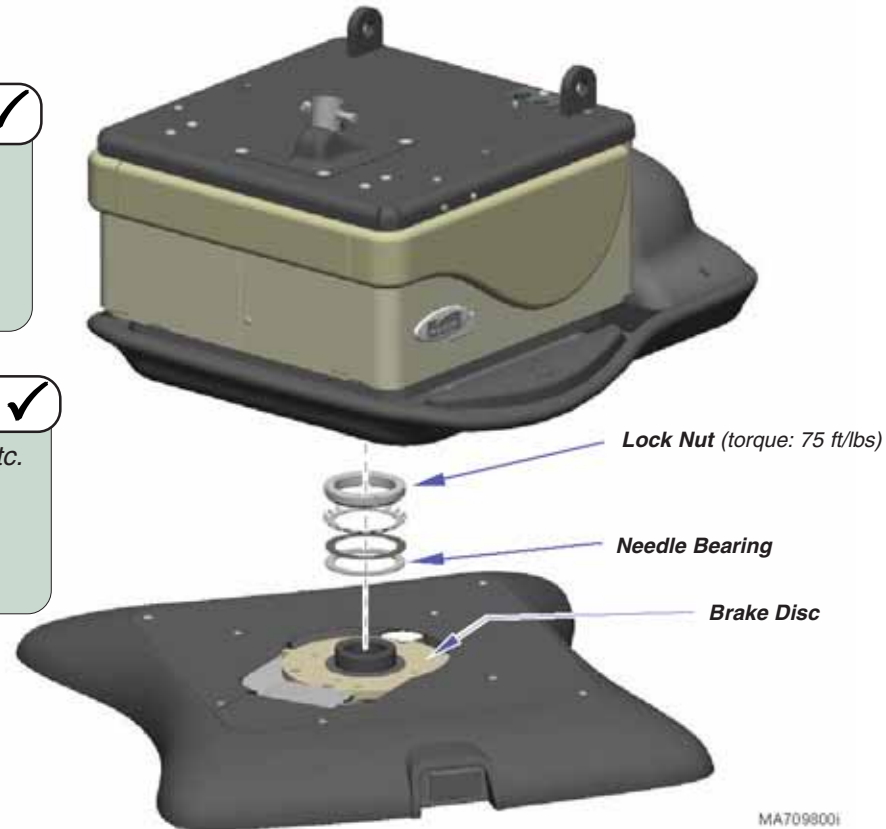

Models: | 230 (-003) | 630 (-005 & -006)
Serial Numbers: | all | all

**Rotational Base
Brake System**

Section B

Component Testing & Repair

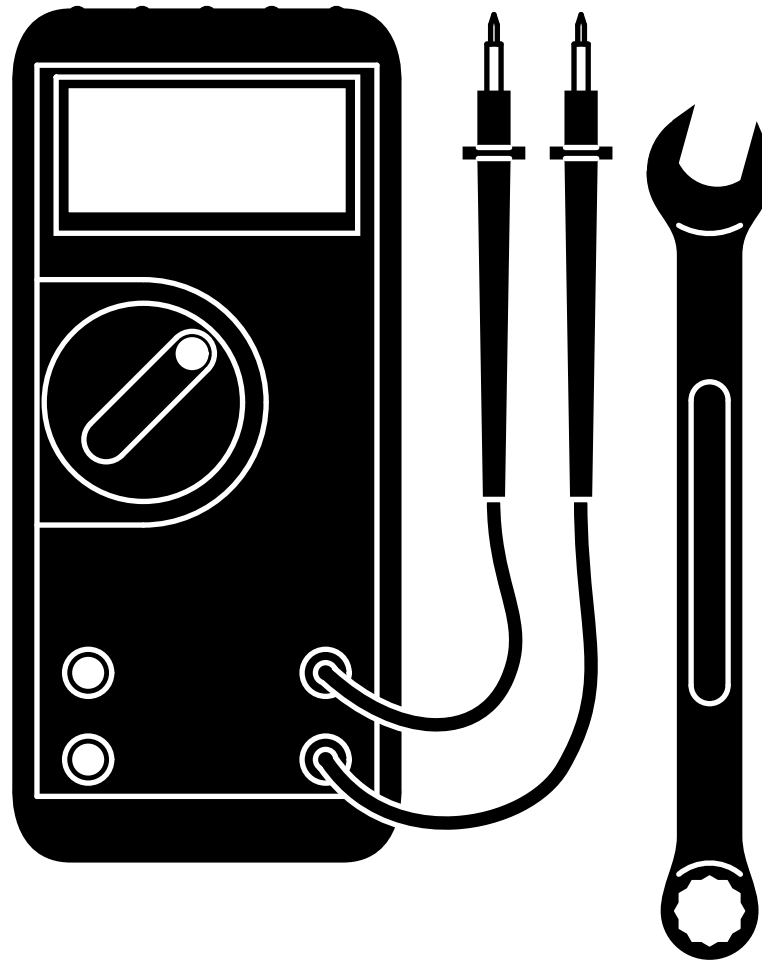

<u>Components</u>	<u>Page</u>
Primary Fuses	B-2
Limit Switches	B-3
Hand / Foot Control	B-6
Base Actuator	B-11
Back Actuator	B-17
Tilt Actuator	B-21
Foot Actuator	B-25
Gas Springs	B-28
Isolation Transformer / Table Receptacles	B-29
Main System Transformer	B-30
Position Sensors	B-32
Main PC Board	B-40
Upholstery Heater System	B-45
Headrest Mechanism	B-50
Rotational Base Brake System	B-51

Component Testing & Repair

Primary Fuses

Location

If Power Indicator Light is...
OFF: No power to table (test the fuses)
ON: Table has power (fuses - OK)

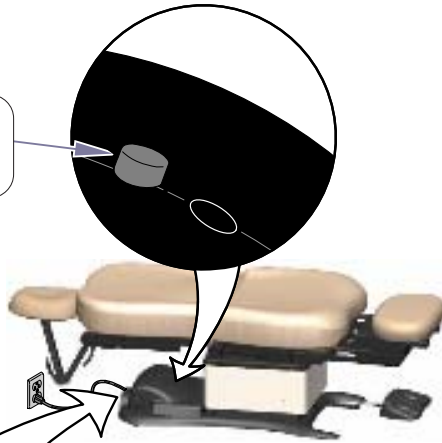

MA651601i

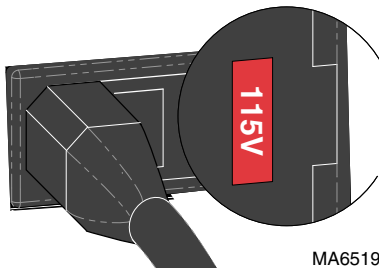
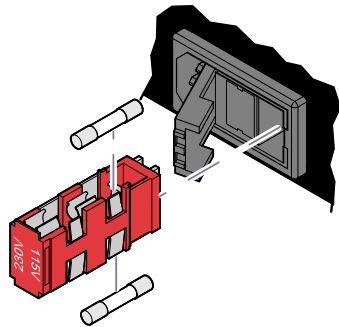

MA651900i

Equipment Alert
 Voltage setting must match facility supply voltage.
 Incorrect setting will result in damage to the table.

Fuse Test

Fuse Test Step 1: Set meter to 200 Ω .

Primary Fuses

Page

Location	B-2
Fuse Test	B-2
Wiring Diagrams	D-1
Fuse Rating	6.3A, 250V
	Type T, 5 x 20mm
Part Number	015-0346-40

Fuse Test Step 2: Place meter probes on each end of fuse.

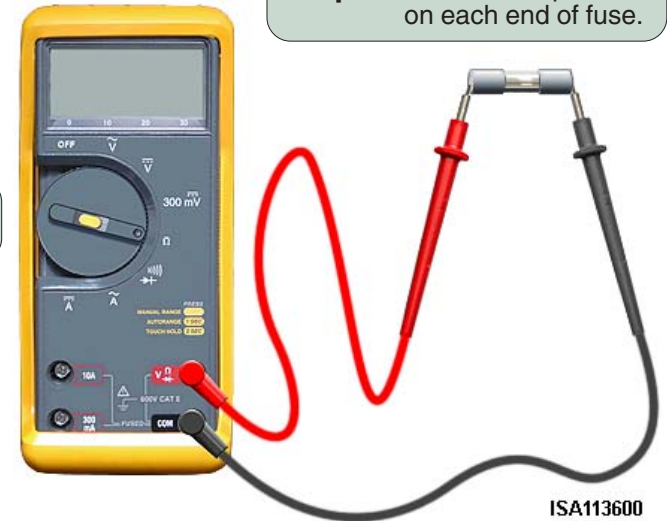

ISA113600

Meter Reading	Status	Required Action
OL		Replace both fuses.
less than 5 Ω		Fuse - OK

Limit Switches

Location

Limit Switches	Page
Location	B-3
Limit Switch / Harness Test	B-4
Access Procedures	C-1
Wiring Diagrams	D-1
Exploded Views / Part Number	E-1

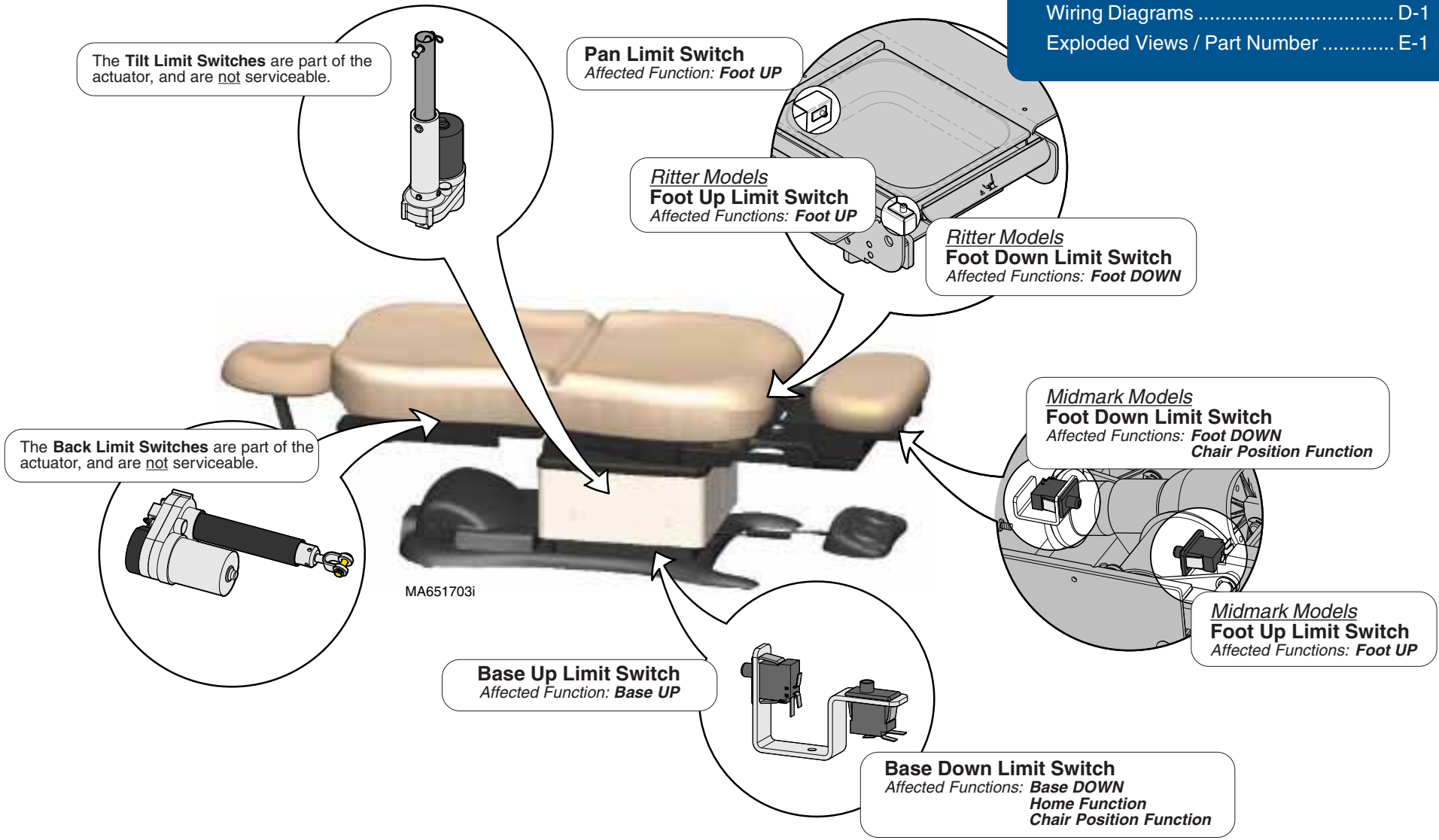

Models: | **ALL**
Serial Numbers: |

Limit Switches

Component Testing & Repair

Limit Switches - continued

Refer To: [Limit Switch Continuity Test](#) **Page** B-5

PC Board Harness Test

Step 1: Disconnect appropriate harness from main PC board. (see illustration)

Step 2: Place one meter probe on the common wire. (see illustration)

Step 3: Place other meter probe on the wire for the appropriate switch (see illustration).
Note: Check switch "tripped" & "untripped".

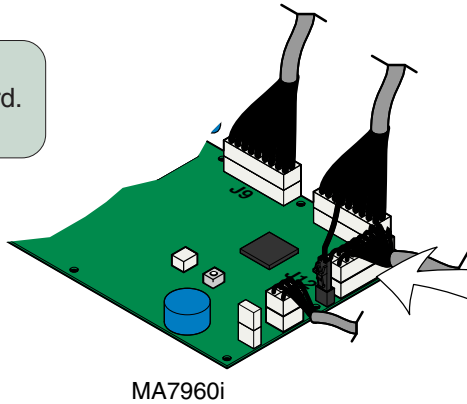

MA7960i

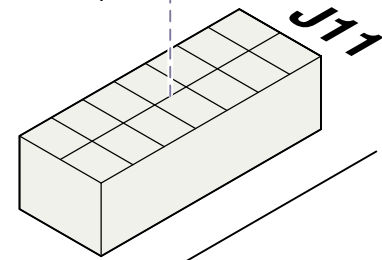
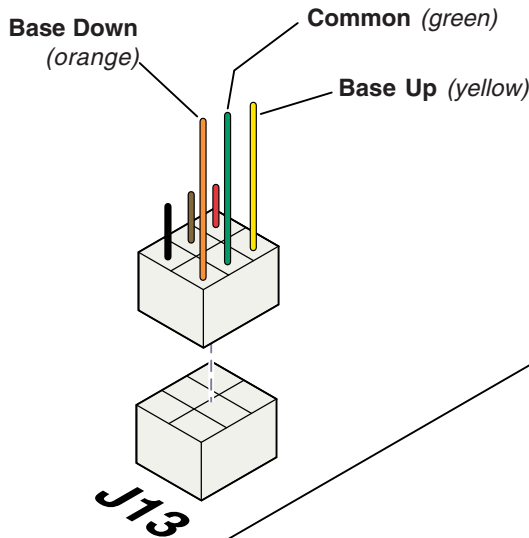
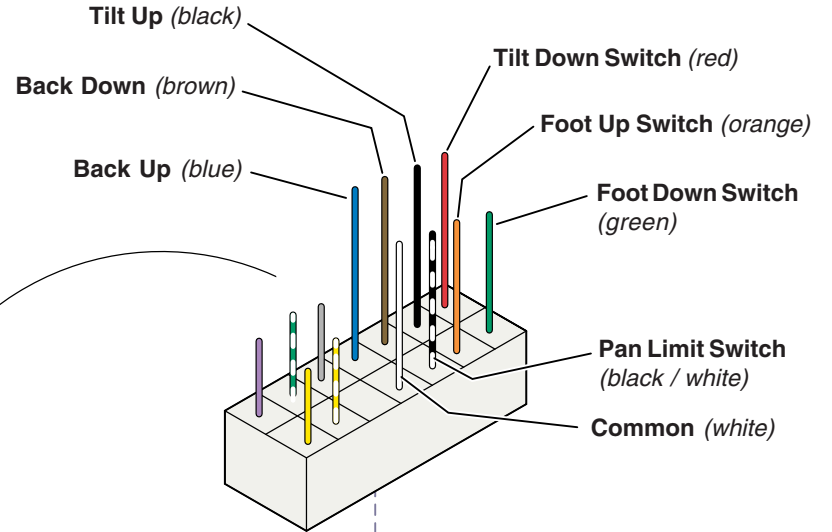

Normally CLOSED switches* "untripped"... -or-
Normally OPEN switches* "tripped"...

Meter Reading	Req'd Action
OL	Perform Limit Switch / Harness Test
less than 10 Ω	Limit switch / harness - OK Test actuator.

Normally CLOSED switches* "tripped"... -or-
Normally OPEN switches* "untripped"...

Meter Reading	Req'd Action
less than 10 Ω	Perform Limit Switch / Harness Test
OL	Limit switch / harness - OK Test actuator.

*** Switch**

Base UP	Normally Closed
Base Down	Normally Closed
Back Up	Normally Closed
Back Down	Normally Closed
Tilt Up	Normally Closed
Tilt Down	Normally Closed
Foot Up	Normally Closed
Foot Down	Normally Closed
Pan Limit Switch	Normally Open

Component Testing & Repair

Limit Switches - continued

Limit Switch Harness Test

Note: This test is for the Foot, Tilt, & Back functions only.
For Base function, perform Limit Switch Continuity Test.

Step 1: Unplug the appropriate limit switch harness.

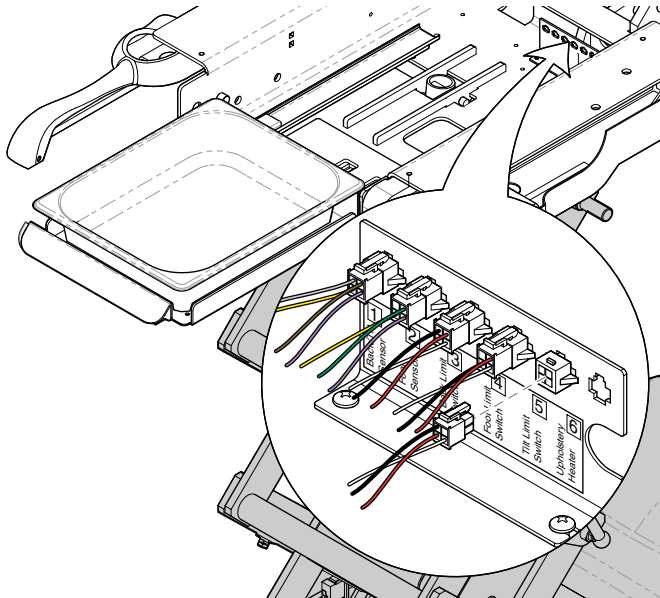

Step 2: Measure continuity,

MA8289i

Meter reading should be...

Actuator Full Up	White to Black - Open
	White to Red - Closed
Actuator Full Down	White to Black - Closed
	White to Red - Open
Actuator Midway Point	White to Black - Closed
	White to Red - Closed

Limit Switch Continuity Test

Attention

The Back & Tilt limit switches are part of the actuator, and are not serviceable.

Step 1: Tag & disconnect wires from switch.



Step 2: Place one meter probe on **COM** terminal.
Place other probe on the **NC** or **NO** terminal.
(depending on the switch*)

Note: Check switch 'tripped' and 'untripped'.

Normally CLOSED switch* "tripped"... -or-
Normally OPEN switch* "untripped"...

Meter Reading	Status	Required Action
OL		Switch - OK. Replace harness
less than 5 Ω		Replace switch

Normally CLOSED switch* "untripped"... -or-
Normally OPEN switch* "tripped"...

Meter Reading	Status	Required Action
OL		Replace switch
less than 5 Ω		Switch - OK. Replace harness

Models:
Serial Numbers:

ALL

Limit Switches

B-5

Component Testing & Repair

Hand & Foot Controls

Isolating a Malfunction



NOTE: Older Ritter models only have one connection port. Go directly to Hand / Foot Control Test.

To isolate a malfunction...

Plug the hand / foot control into the other connection port.

Does the hand / foot control work properly?

If **YES**, replace the wire harness at the malfunctioning connection port. (Refer to *Wiring Diagrams* for part number).

If **NO**, perform the *Hand / Foot Control Test*.

Hand & Foot Controls	Page
Isolating a Malfunction	B-6
Hand / Foot Control Test	B-7
Control Cord Continuity Test	B-8
Repair Procedures:	
<i>Hand Control</i>	B-9
<i>Foot Control</i>	B-10
Wiring Diagrams	D-1
Exploded View / Part Numbers:	
<i>Foot Control (Disc-style)</i>	E-20*
<i>Foot Control (Linear-style)</i>	E-21
<i>Hand Control</i>	E-22



Component Testing & Repair

Hand & Foot Controls - continued

Hand / Foot Control Test

Refer To:	Page
Control Cord Test	B-8
PC Board Cover Removal:	
<i>models w/ Standard Base</i>	C-2
<i>models w/Rotational Base</i>	C-3

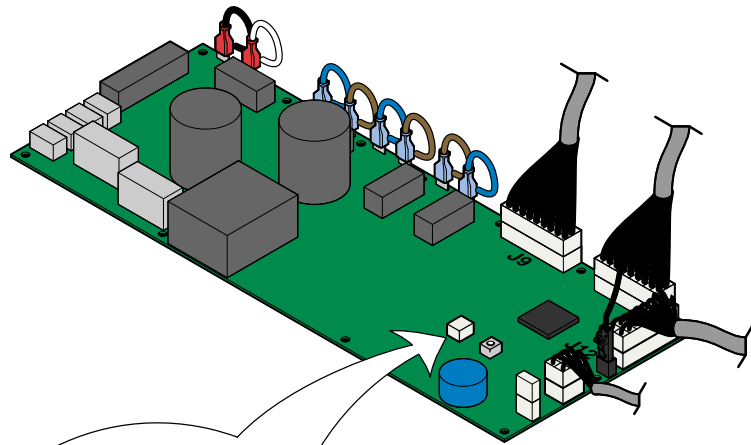

MA653000i

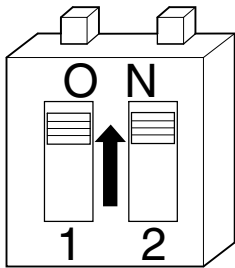

MODE SELECT

Hand/Foot Control Test
Step 1: Move both switches on
 MODE SELECT block to ON.

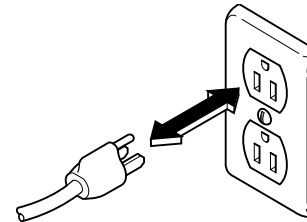

Hand/Foot Control Test
Step 2: Unplug table (to reset PC Board).
 Plug table back in.

Hand/Foot Control Test
Step 3: One at a time, press & hold each button on
 the hand / foot control.

Do you hear "beeps" each time a button is pressed?

If **YES**, that button is functioning properly.
 If **NO**, perform the *Control Cord Test*.



ATTENTION!
To return to normal operation...
 A. Move MODE SELECT block switches
 back to original position.
 B. Unplug table (to reset board).
 C. Plug table back in.

Models: ALL
Serial Numbers:

Hand & Foot Controls

Component Testing & Repair

Hand & Foot Controls - continued

Control Cord Test

Attention

The hand & foot control cords are interchangeable. If a working cord is available, switch the cords to test. If one is not available, perform the Continuity Test.

Continuity Test

Step 1: Disconnect cord from hand / foot control. [Refer to *Repair Procedures* for instruction]

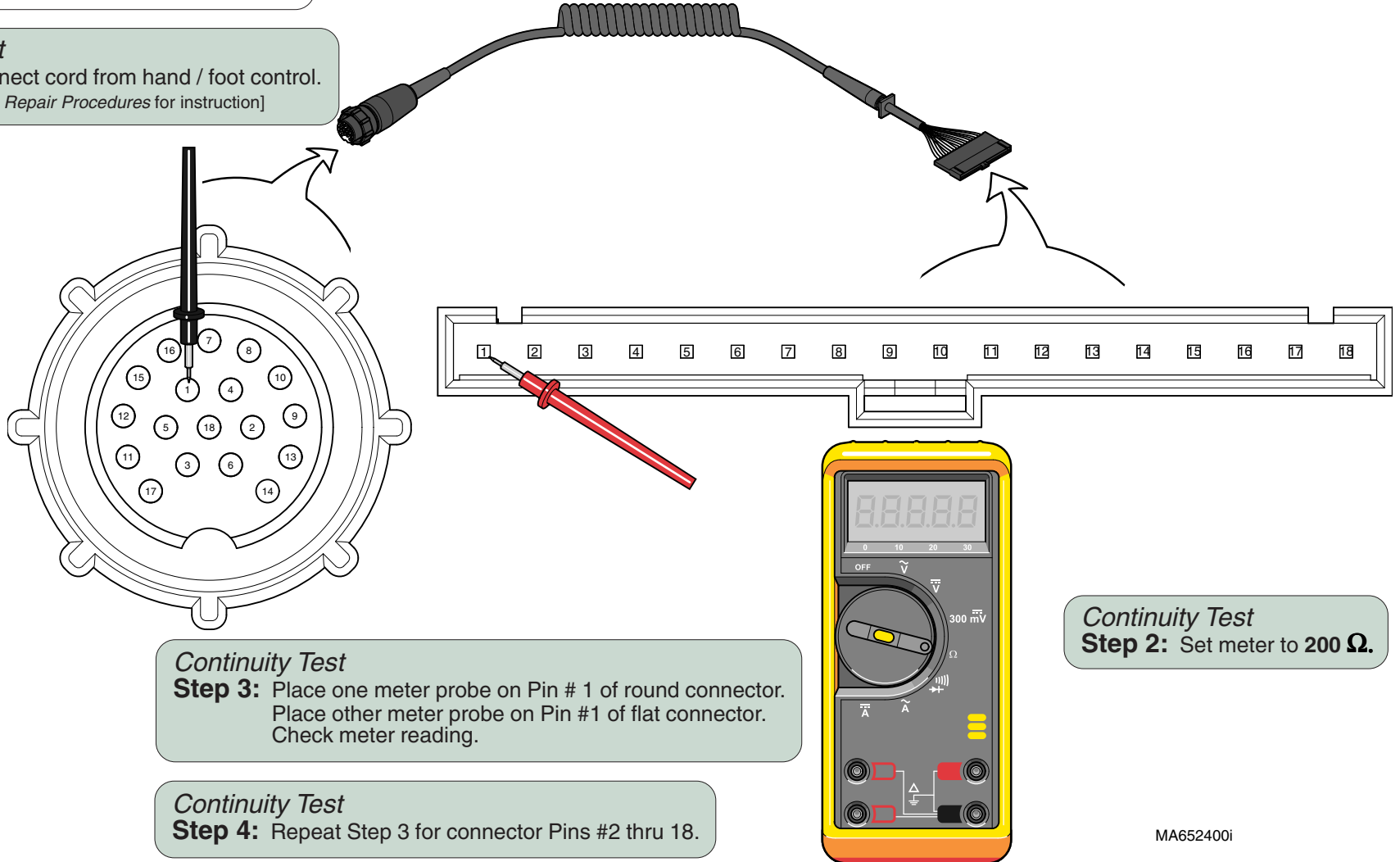

Continuity Test

Step 3: Place one meter probe on Pin # 1 of round connector. Place other meter probe on Pin #1 of flat connector. Check meter reading.

Continuity Test

Step 4: Repeat Step 3 for connector Pins #2 thru 18.

Continuity Test

Step 2: Set meter to 200 Ω.

MA652400i

Component Testing & Repair

Hand & Foot Controls - continued

Hand Control Repair Procedure

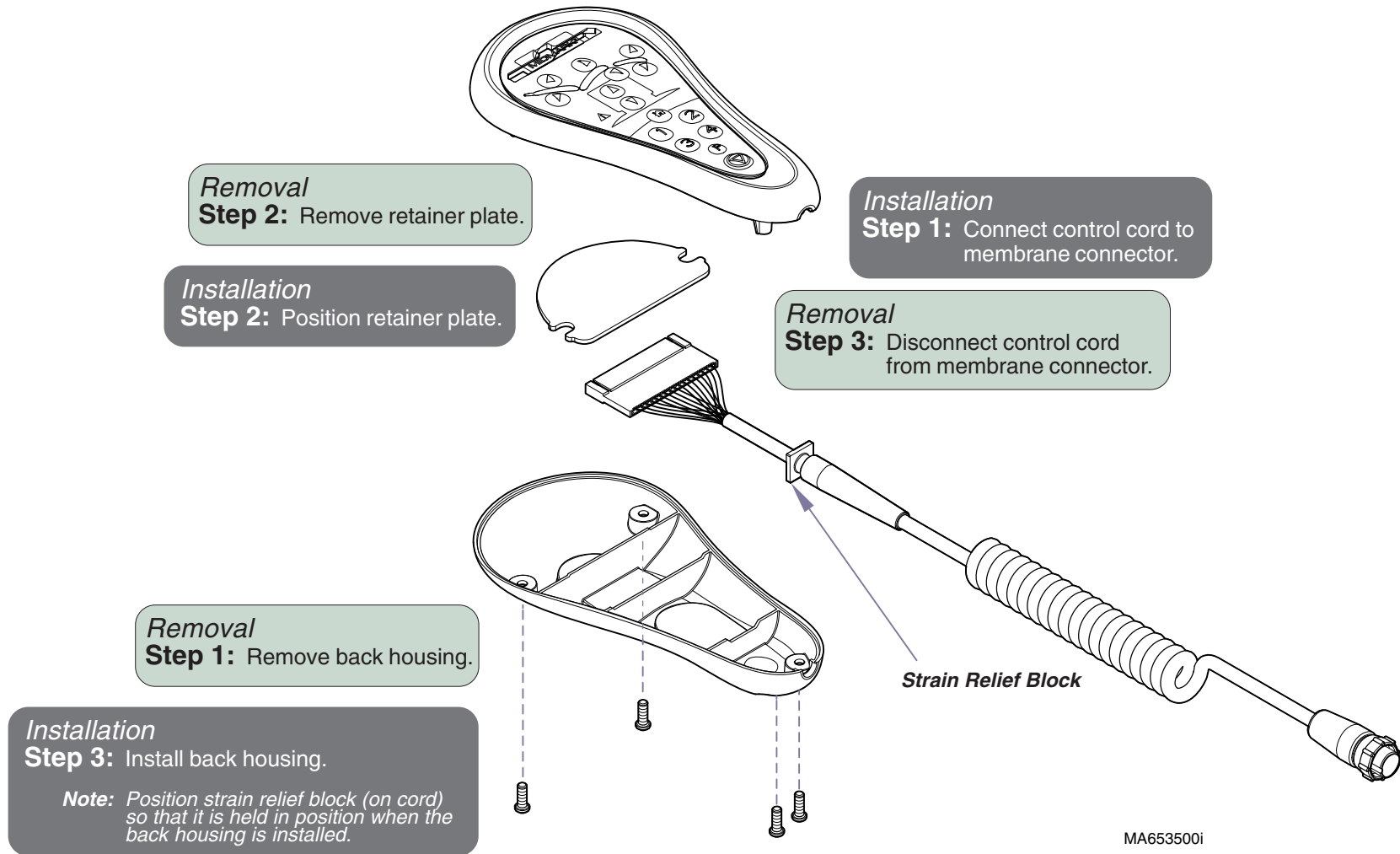

Models:
Serial Numbers:

ALL

Hand & Foot Controls

© Midmark Corporation 2005 SF-1838

Component Testing & Repair

Hand & Foot Controls - continued

Foot Control Repair Procedure

Removal (if necessary)

Step 3: Peel touch pad off of membrane panel.

Installation (if necessary)

Step 1: Install touch pad onto membrane panel.

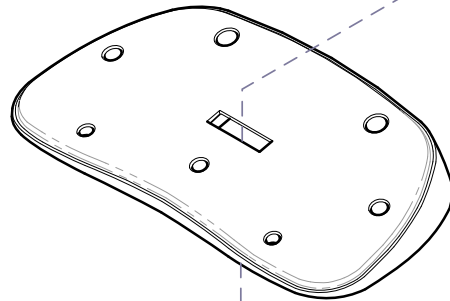
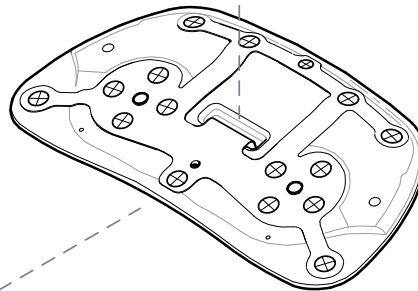
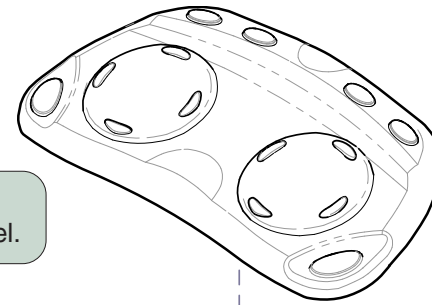

Strain Relief Block

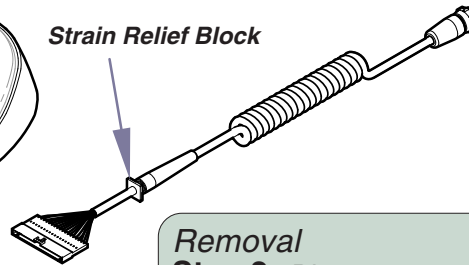

Removal

Step 2: Disconnect control cord from membrane connector.

Installation

Step 2: Insert control cord thru hole in base. Connect to membrane connector.

Note: Slide strain relief block (on cord) into slot on base.

Removal

Step 1: Remove base plate.

Installation

Step 3: Install base plate.

MA653400i

Base Actuator

Isolating a Malfunction

This illustration shows the three serviceable components of the base actuator. Use the table below to isolate the malfunction.

Problem	Required Action
Motor runs, but makes grinding noise.	Clean / lube actuator threads. Replace actuator if necessary.
Motor runs, but table does not move.	Inspect / replace motor coupler.
Motor does not run.	Perform Actuator Motor Test

Base Actuator	Page
Isolating a Malfunction	B-11
Actuator Motor Test	B-12
PC Board Test	B-13
Motor / Motor Coupler Replacement	B-14
Actuator Removal	B-15
Actuator Installation	B-16
Wiring Diagrams	D-1
Exploded View / Part Numbers	E-24

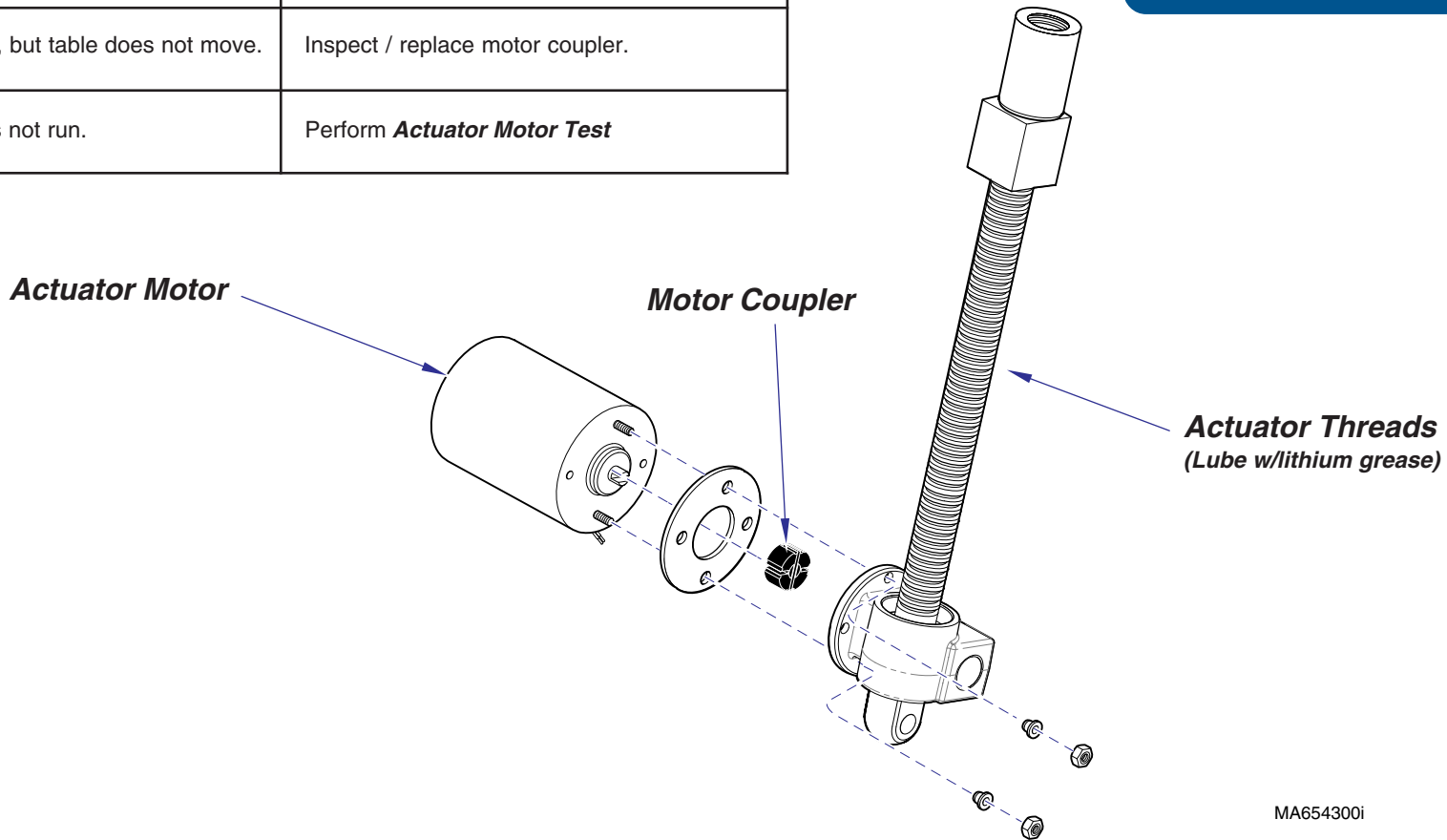

MA654300i

Component Testing & Repair

Base Actuator - continued

Actuator Motor Test

Actuator Motor Test

Step 1: Tag, then disconnect base actuator wires (J1 & J2).

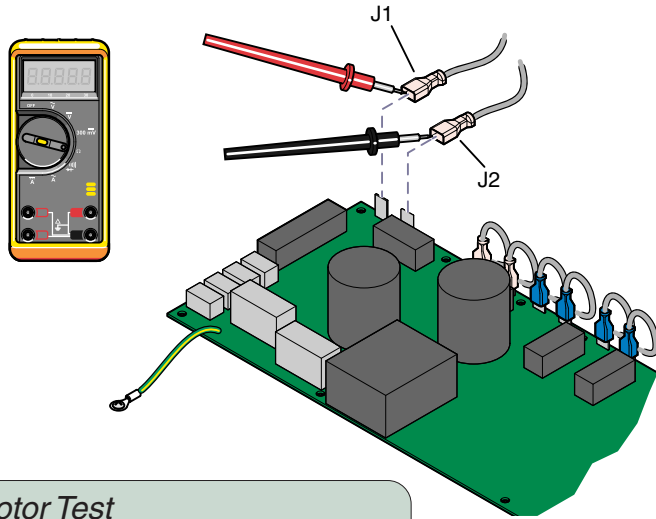

Actuator Motor Test

Step 2: Place meter probes on actuator wires. Check meter reading.

Meter Reading	Status	Required Action
1 to 10 Ω		Actuator motor - OK. Perform Motor Ground Test
OL -or- less than 1 Ω		Replace motor*.

*Replacement instructions are provided with the part. They are also available on Documark.com, or by clicking on the link in the blue box.

Refer To:

Page

PC Board Test	B-13
PC Board Cover Removal models w/ Standard Base	C-2
models w/Rotational Base	C-3

Motor Ground Test

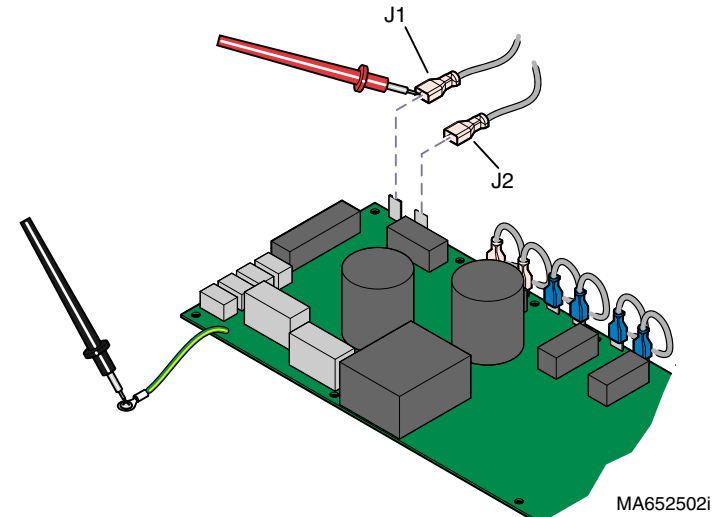

Motor Ground Test

Step 1: Place one meter probe on actuator wire (J1). Place other meter probe on PC board ground wire. Check meter reading. (Repeat for J2)

Meter Reading	Status	Required Action
OL -or- more than 1 M Ω		Motor harness - OK. Perform PC Board Test
less than 1 Ω		Replace motor*.

Component Testing & Repair

Base Actuator - continued

PC Board Test

PC Board Test

Step 1: Move **BACK** section so that it is approx. halfway between its maximum & minimum positions.

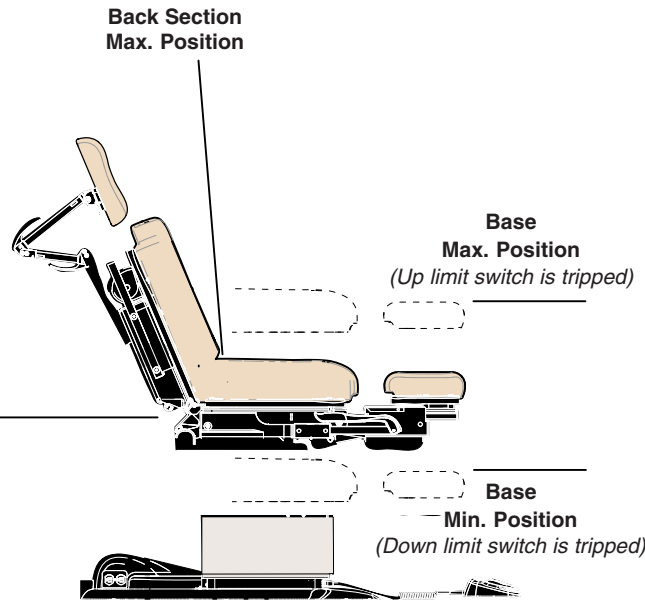

Refer To:

Page

PC Board Replacement B-45

PC Board Cover Removal:

models w/ Standard Base C-2

models w/Rotational Base C-3

PC Board Test

Step 2: This test **cannot** be performed if either base limit switch is tripped.

If necessary, remove switch bracket. (Switch wires **must** remain connected)

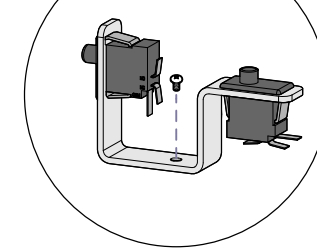

PC Board Test

Step 3: Disconnect base actuator wires from J1 & J2.

Back Section
Min. Position

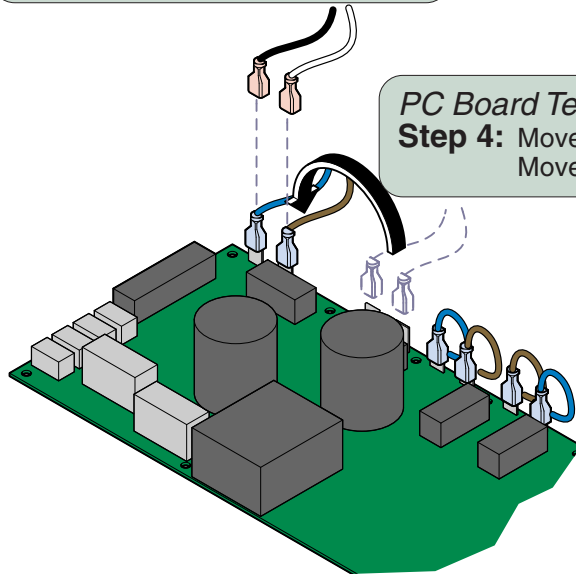

PC Board Test

Step 4: Move blue wire from J3 to J1.
Move brown wire from J4 to J2.

MA655400i



Equipment Alert

The back limit switches will not stop movement during this test.

Do not run past max. / min. positions.



PC Board Test

Step 5: Press & hold Base Up button (on the hand or foot control) for 5 seconds.

Does **back section** move up briefly, then stop & "beep"?
If **YES**, go to Step 6.
If **NO**, replace PC Board.

PC Board Test

Step 6: Press & hold Base Down button (on the hand or foot control) for 5 seconds.

Does **back section** move down briefly, then stop & "beep"?
If **YES**, PC Board is OK.
If **NO**, replace PC Board.

Models:
Serial Numbers:

ALL

Base Actuator

B-13

Component Testing & Repair

Base Actuator - continued

Motor / Motor Coupler Replacement

Removal
Step 1: Raise base as high as possible.

Removal
Step 2: Disconnect base actuator wires from choke harness.
Disconnect ground wire.
Note: Remove cable ties & wire clamps as necessary.

Installation
Step 2: Connect actuator wires to choke harness.
[white to white] [black to black]
Connect ground wire.
Note: Replace all cable ties & wire clamps.

Removal
Step 3: Remove two nuts,
motor, gasket, & coupler.

Installation
Step 1: Install coupler, gasket, and motor.
Secure with two nuts.

Refer To:	Page
PC Board Cover Removal:	
models w/ Standard Base	C-2
models w/Rotational Base	C-3
Base Shrouds:	
Raising (w/bungee cord)	C-4
Removal	C-5

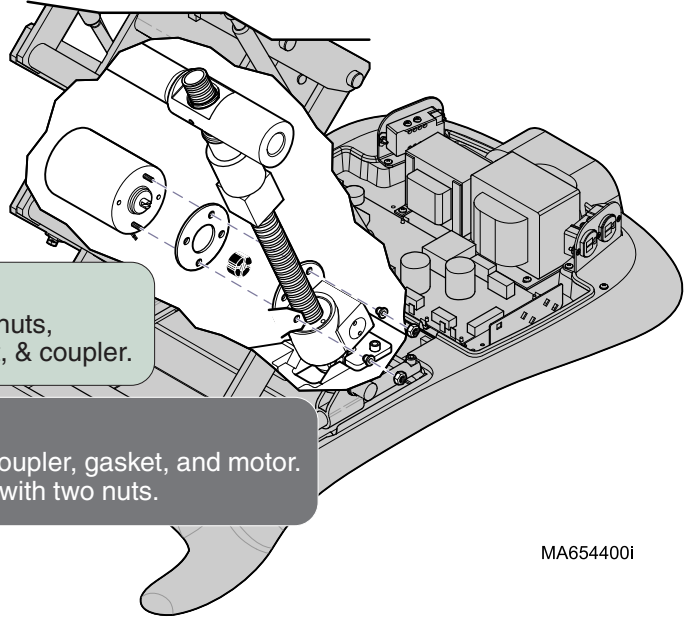
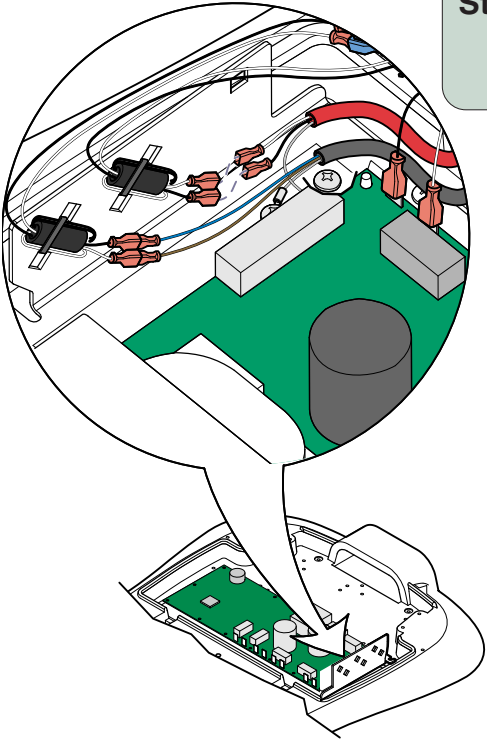

MA654400i

Base Actuator - continued

Actuator Removal

Removal

Step 1: Run Base Up function to maximum height.

Removal

Step 3: Disconnect base actuator wires from choke harness. Disconnect ground wire.

Note: Remove cable ties & wire clamps as necessary.

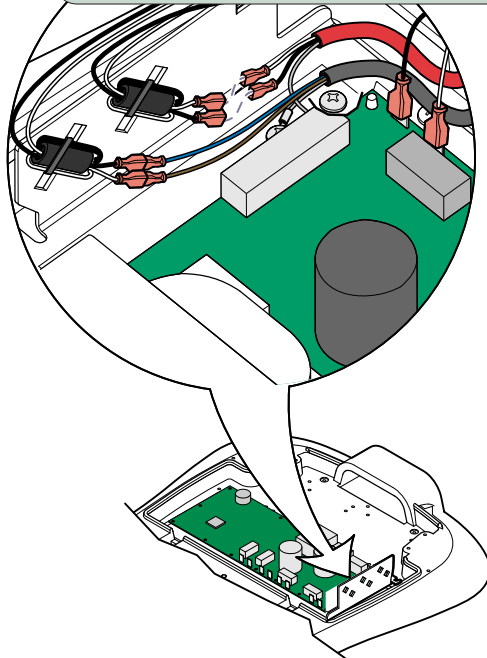

Removal

Step 4: Remove retaining ring. Loosen set screw.

Retaining Ring

Set Screw

Removal

Step 5: Manually rotate the collar & block to the bottom of the actuator shaft.

Removal

Step 6: Remove retainer plate and actuator.

Stop Bolt

Removal

Step 2: Install the Stop Bolt (included w/actuator kit).



Caution

The gas springs **may** support the full weight of the table, but the stop bolt is still required to ensure safety.

MA654001i

Models:
Serial Numbers:

ALL

Base Actuator

B-15

Component Testing & Repair

Base Actuator - continued

Actuator Installation

Installation

Step 6: Connect actuator wires to choke harness.
 [white to white] [black to black]
 Connect ground wire.

Note: Replace all cable ties & wire clamps.
 Raise table & remove stop bolt.

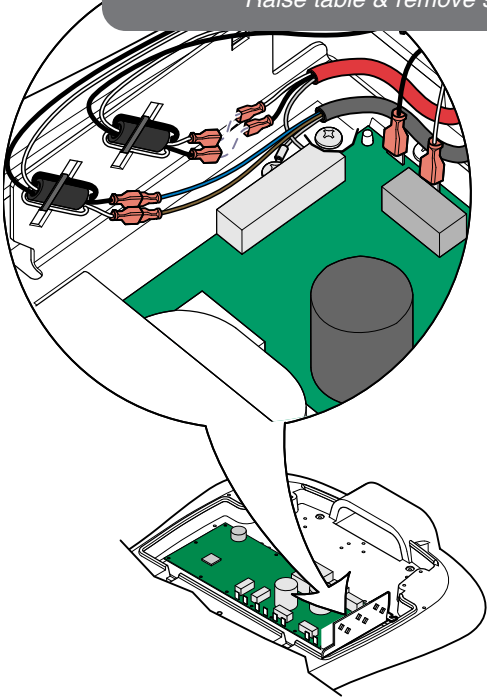

Refer To:	Page
PC Board Cover Removal:	
models w/ Standard Base	C-2
models w/Rotational Base	C-3
Base Shrouds:	
Raising (w/bungee cord)	C-4
Removal	C-5

Installation
Step 4: Install retaining ring.
 Tighten set screw.

Installation
Step 3: Push table top down, until top of collar sticks thru cross bar.

Retaining Ring

Set Screw

Installation
Step 2: Manually rotate the collar and block to the top of the actuator shaft.

Installation
Step 5: Install retainer plate and secure with screws.

Installation
Step 1: Insert actuator shaft thru hole.
 Position actuator with bottom pin in slot.

Stop Bolt

MA654600i

Back Actuator

[NOTE: The Back Actuator has no serviceable components. If the actuator malfunctions, it must be replaced.]

Actuator Motor Test

Actuator Motor Test

Step 1: Tag / disconnect back actuator wires (J3 & J4).

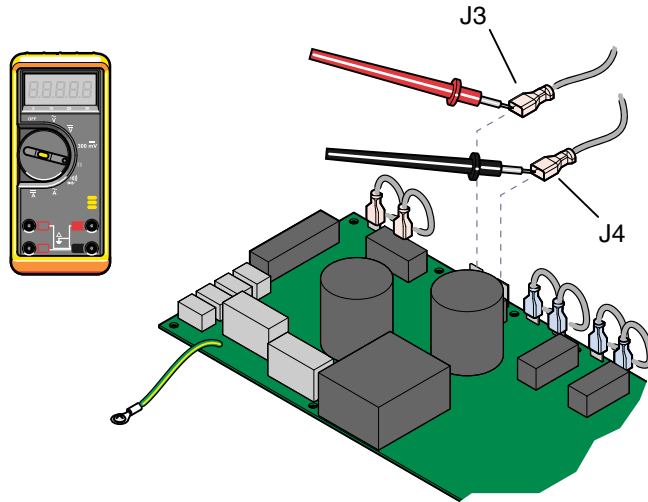

Actuator Motor Test

Step 2: Place meter probes on actuator wires. Check meter reading.

Meter Reading	Status	Required Action
1 to 10 Ω		Actuator motor - OK. Perform Motor Ground Test
OL -or- less than 1 Ω		Replace motor*.

Motor Ground Test

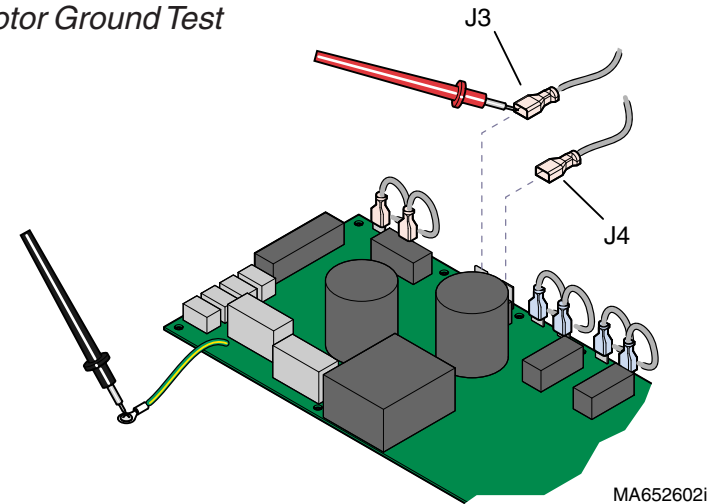

Motor Ground Test

Step 1: Place one meter probe on actuator wire (J3). Place other meter probe on PC board ground wire. Check meter reading. (Repeat for J4)

Meter Reading	Status	Required Action
OL -or- more than 1 M Ω		Motor harness - OK. Perform PC Board Test
less than 1 Ω		Replace motor*.

Back Actuator

Page

Actuator Motor Test B-17

PC Board Test B-18

Actuator Replacement B-19

Wiring Diagrams D-1

Exploded View / Part Numbers:

Midmark models E-11

Ritter models E-12

Models:
Serial Numbers:

ALL

Back Actuator

Component Testing & Repair

Back Actuator - continued

PC Board Test

PC Board Test

Step 1: This test cannot be performed with the back section in the max. or min. position.

If necessary, reposition the back section.
Refer to: *Base Actuator - PC Board Test*

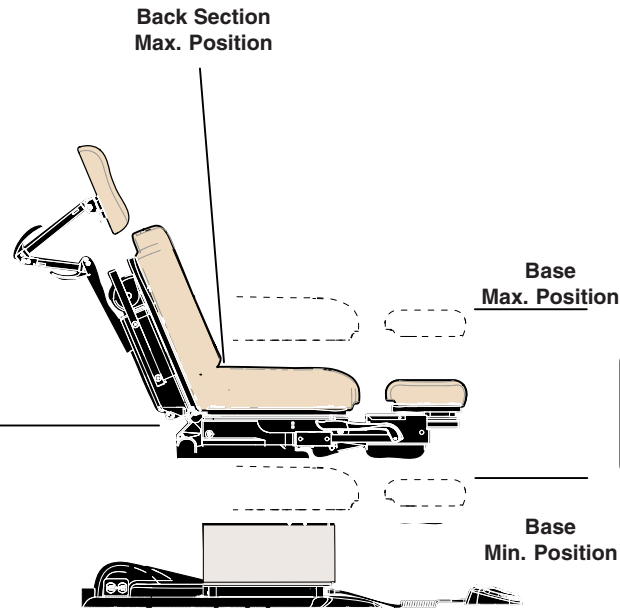

PC Board Test

Step 2: Move the **BASE** function so that it is approx. halfway between the maximum & minimum positions.

PC Board Test

Step 3: Disconnect back actuator wires from J3 & J4.

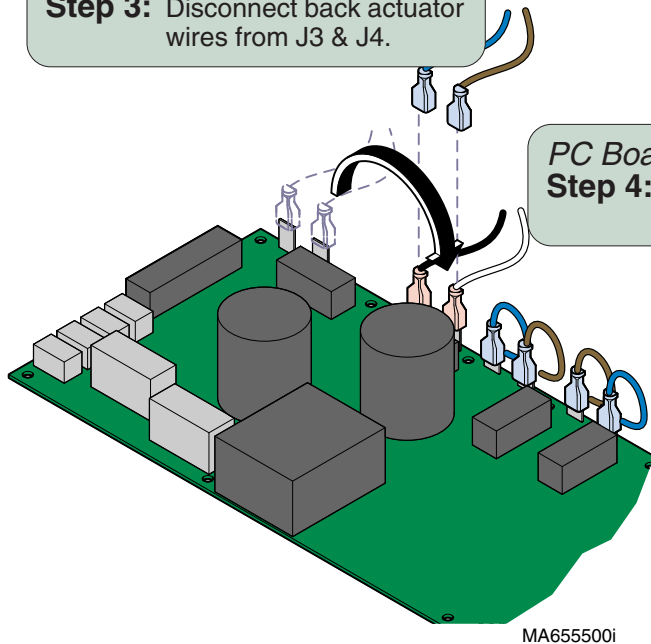

PC Board Test

Step 4: Move black wire from J1 to J3.
Move white wire from J2 to J4.



Equipment Alert

The base limit switches will not stop movement during this test.

Do not run past max. / min. positions.



PC Board Test

Step 5: Press & hold Back Up button for 5 seconds.

Does the **base** move up, then stop & "beep"?
If **YES**, go to Step 6.
If **NO**, replace PC Board.

PC Board Test

Step 6: Press & hold Back Down button for 5 seconds.

Does the **base** move down, then stop & "beep"?
If **YES**, PC Board is OK.
If **NO**, replace PC Board.

Back Actuator - continued

Actuator Replacement

Tape

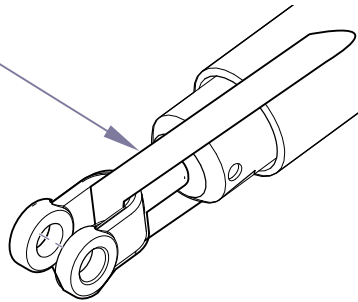

Equipment Alert

Do **not** remove tape from new actuator, until instructed to do so.

Doing so will allow the actuator shaft & yoke to rotate resulting in misalignment of the internal limit switches

Refer To:

Page

PC Board Cover Removal:

models w/ Standard Base C-2

models w/Rotational Base C-3

Base Shrouds:

Raising (w/bungee cord) C-4

Removal C-5

Back Section Covers C-7

Seat Section Covers C-8

Removal

Step 1: Disconnect back actuator wires from choke harness. Disconnect ground wire. Pull actuator wire up thru table.

Note: Remove cable ties & wire clamps as necessary.

Installation

Step 4: Route actuator wire down thru table. Connect actuator wires to choke harness. [brown to brown] [blue to blue] Connect ground wire.

Note: Replace all cable ties & wire clamps.

Installation

Step 3: Route back limit switch harness and connect to junction board.

Removal

Step 2: Disconnect back limit switch harness [3] from junction board.

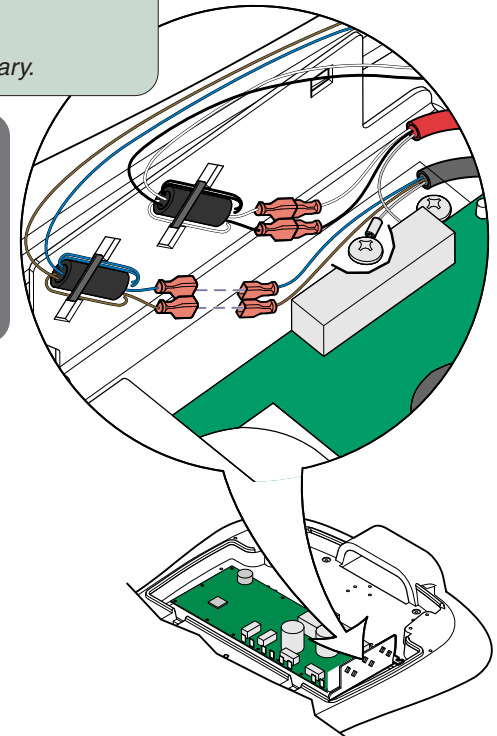
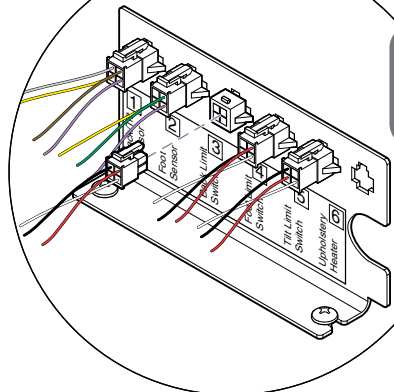
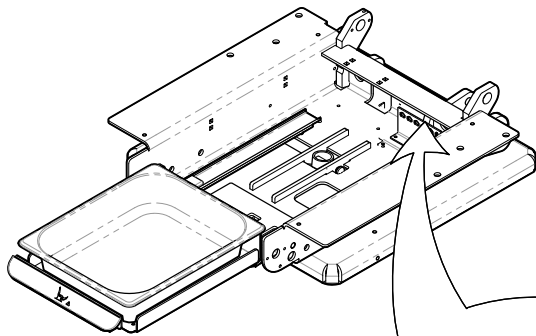

MA696102I

Models:
Serial Numbers:

ALL

Back Actuator

B-19

Component Testing & Repair

Back Actuator - continued

Actuator Replacement - continued

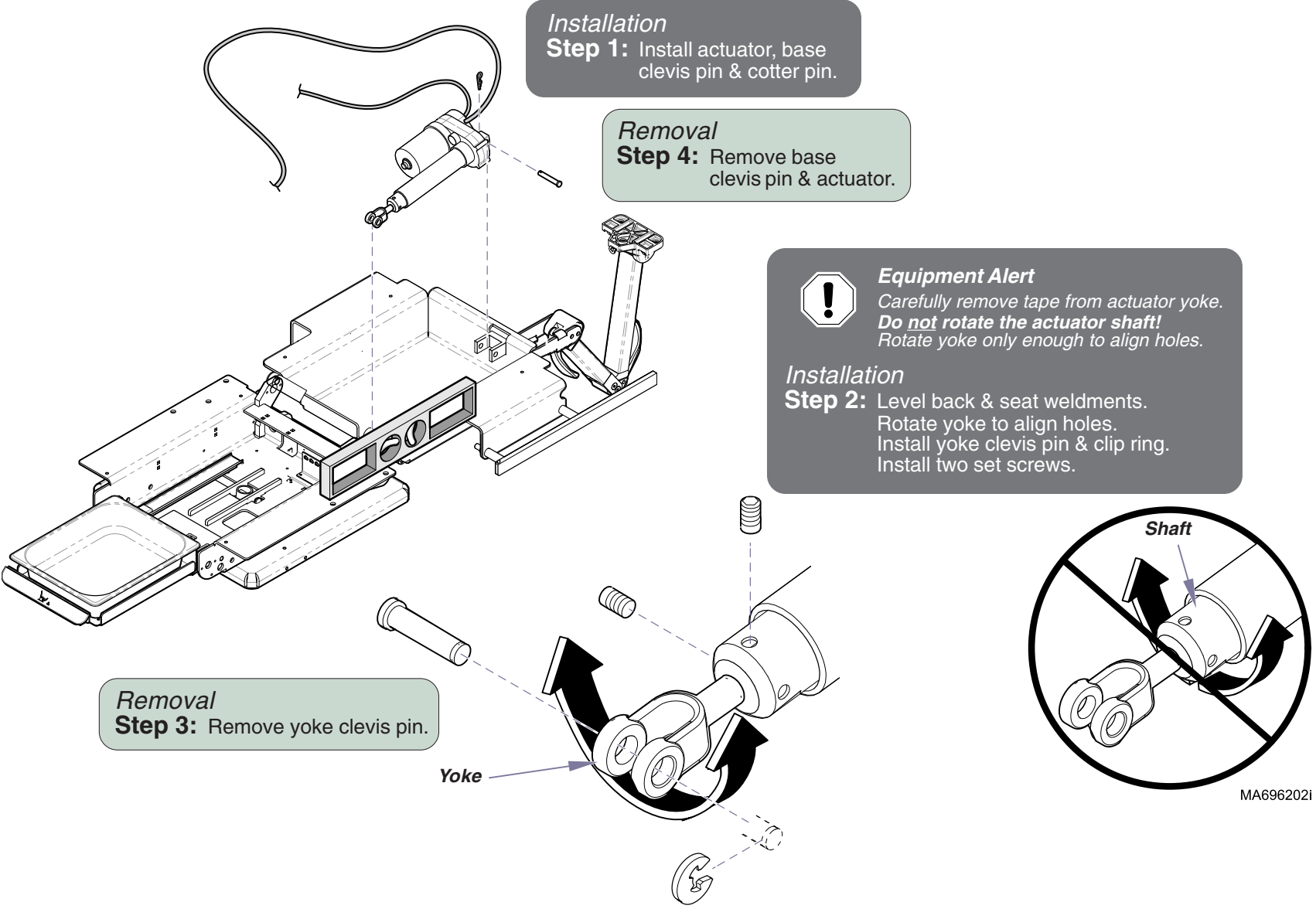

Removal
Step 3: Remove yoke clevis pin.

Installation
Step 1: Install actuator, base clevis pin & cotter pin.

Removal
Step 4: Remove base clevis pin & actuator.

Equipment Alert
Carefully remove tape from actuator yoke.
Do not rotate the actuator shaft!
Rotate yoke only enough to align holes.

Installation
Step 2: Level back & seat weldments.
Rotate yoke to align holes.
Install yoke clevis pin & clip ring.
Install two set screws.

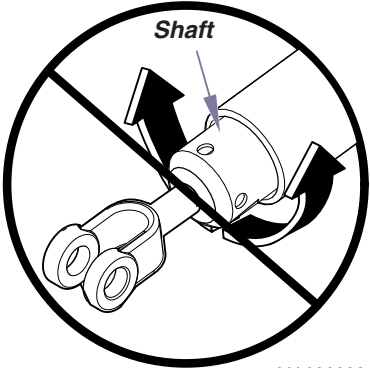

MA6962021

Tilt Actuator

[NOTE: The Tilt Actuator has no serviceable components. If the actuator malfunctions, it must be replaced.]

Actuator Motor Test

Actuator Motor Test

Step 1: Tag, then disconnect tilt actuator wires (J7 & J8).

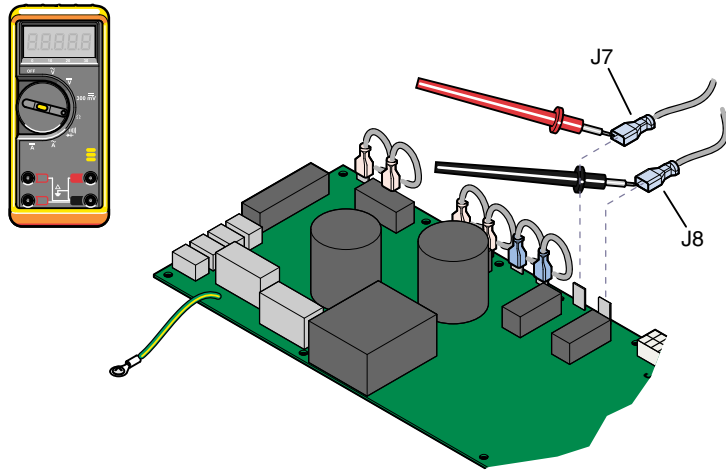

Actuator Motor Test

Step 2: Place meter probes on actuator wires. Check meter reading.

Meter Reading	Status	Required Action
1 to 10 Ω		Actuator motor - OK. Perform Motor Ground Test
OL -or- less than 1 Ω		Replace motor*.

Motor Ground Test

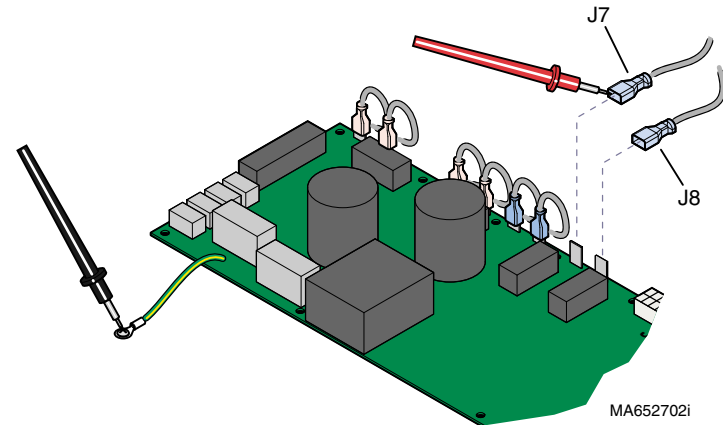

Motor Ground Test

Step 1: Place one meter probe on actuator wire (J7). Place other meter probe on PC board ground wire. Check meter reading. (Repeat for J8)

Meter Reading	Status	Required Action
OL -or- more than 1 M Ω		Motor harness - OK. Perform PC Board Test
less than 1 Ω		Replace motor*.

Tilt Actuator

Page

Actuator Motor Test	B-21
PC Board Test	B-22
Actuator Replacement	B-23
Wiring Diagrams	D-1
Exploded View / Part Numbers	E-17

Models:
Serial Numbers:

ALL

Tilt Actuator

B-21

Component Testing & Repair

Tilt Actuator - continued

PC Board Test

PC Board Test

Step 1: This test cannot be performed with the tilt function in the max. or min. position.

If necessary, reposition the tilt function.
Refer to: *Foot Actuator - PC Board Test*

PC Board Test

Step 3: Disconnect tilt actuator wires from J7 & J8.

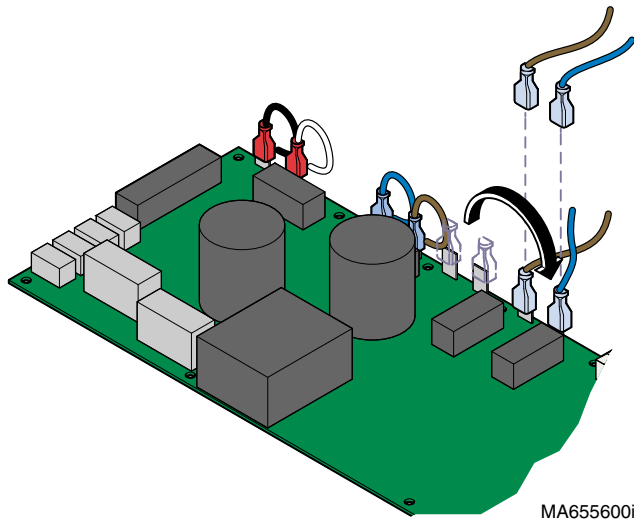

PC Board Test

Step 4: Move brown wire from J6 to J7.
Move blue wire from J5 to J8.

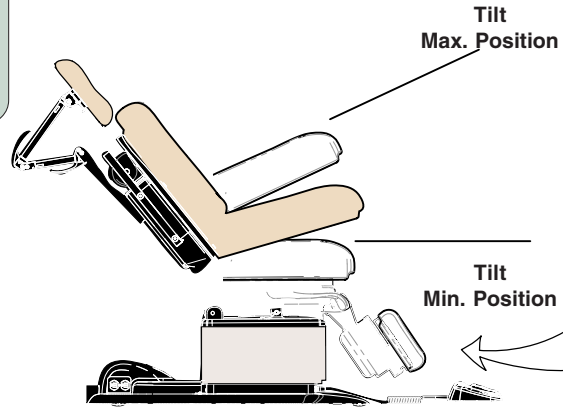

Foot Section

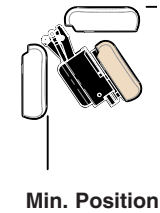

PC Board Test
Step 2: Move the **FOOT** section halfway between the max. & min. positions.

Refer To:

Page

PC Board Cover Removal:

models w/ Standard Base C-2

models w/Rotational Base C-3

Base Shrouds:

Raising (w/bungee cord) C-4

Removal C-5

Seat Section Covers C-8



Equipment Alert

The foot limit switches will not stop movement during this test.

Do not run past max. / min. positions.



PC Board Test

Step 5: Press & hold Tilt Up button for 5 seconds.

Does the **foot section** move up, then stop & "beep"?
If **YES**, go to Step 6.
If **NO**, replace PC Board.

PC Board Test

Step 6: Press & hold Tilt Down button for 5 seconds.

Does the **foot section** move down, then stop & "beep"?
If **YES**, PC Board is OK.
If **NO**, replace PC Board.

Tilt Actuator - continued

Actuator Replacement

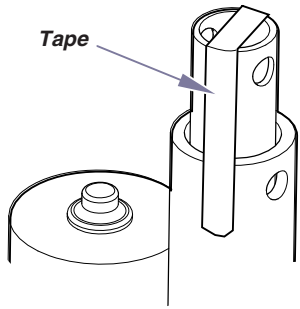

Equipment Alert

Do **not** remove tape from new actuator, until instructed to do so.

Doing so will allow the actuator shaft to rotate resulting in misalignment of the internal limit switches

Installation

Step 5: Route actuator wire thru table.
Connect actuator wires to PC board.
[brown - J7] [blue - J8]

Note: Replace all cable ties & wire clamps.

Removal

Step 1: Disconnect tilt actuator wires from PC board.
Pull actuator wire up thru table.

Note: Remove cable ties & wire clamps as necessary.

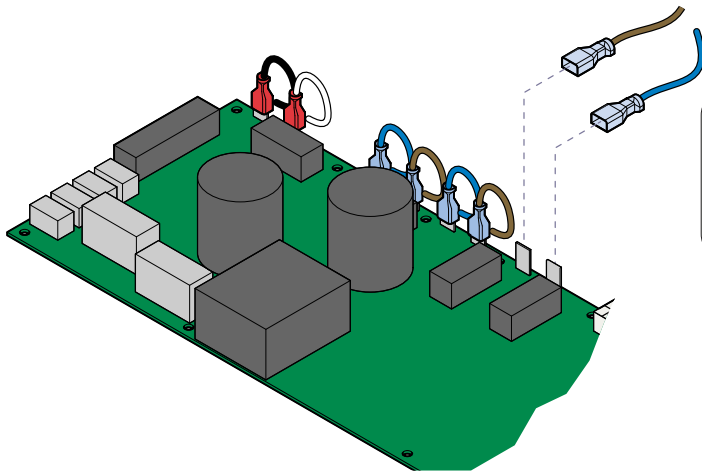

Refer To:

Page

PC Board Cover Removal:

models w/ Standard Base C-2

models w/Rotational Base C-3

Base Shrouds:

Raising (w/bungee cord) C-4

Removal C-5

Seat Section Covers C-8

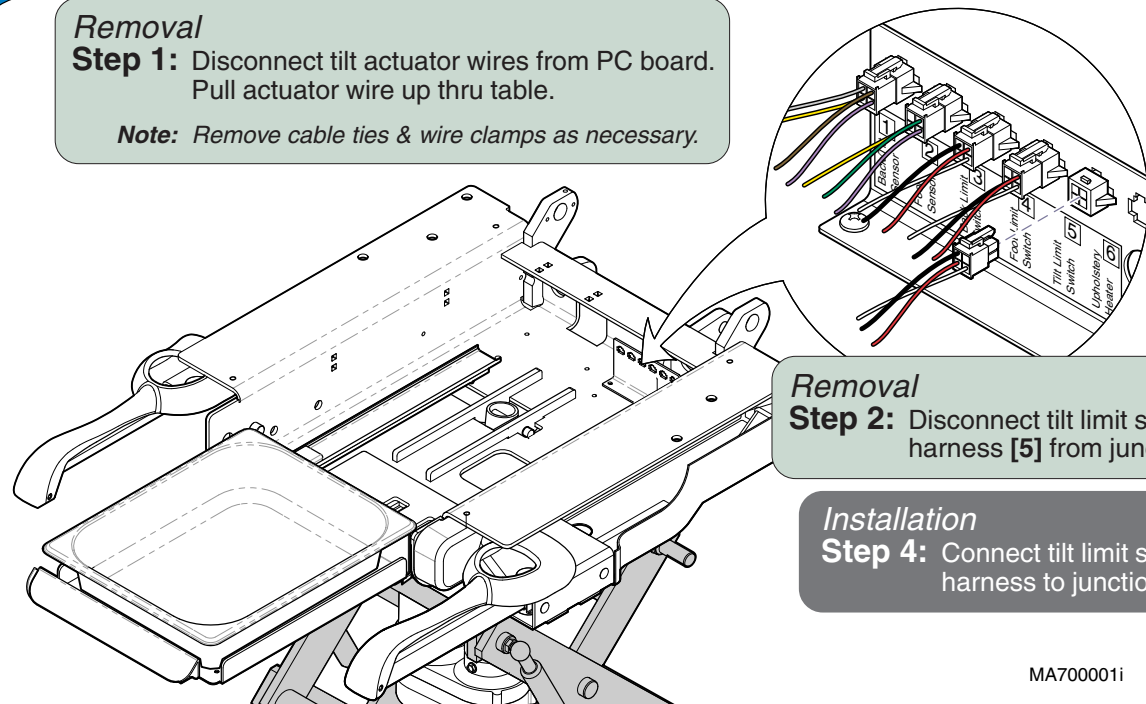

Removal

Step 2: Disconnect tilt limit switch harness [5] from junction board.

Installation

Step 4: Connect tilt limit switch wire harness to junction board.

MA700001i

Models:
Serial Numbers:

ALL

Tilt Actuator

B-23

Component Testing & Repair

Tilt Actuator - continued

Actuator Replacement - continued

Removal
Step 3: Remove clevis pin.

Equipment Alert
Carefully remove tape from actuator shaft.
Do not rotate actuator shaft!

Installation
Step 3: Install clevis pin & cotter pin.

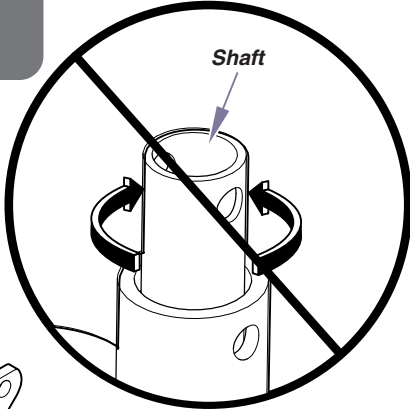

Removal
Step 5: Remove jam nuts, pivot screws, & actuator.

Installation
Step 2: Position actuator then install pivot screws, and jam nuts.

Removal
Ritter models only
Step 4: Remove support strap.

Installation
Ritter models only
Step 1: Install support strap.

MA700101i

Foot Actuator

[NOTE: The Foot Actuator has no serviceable components. If the actuator malfunctions, it must be replaced.]

Actuator Motor Test

Actuator Motor Test

Step 1: Tag / disconnect foot actuator wires (J5 & J6).

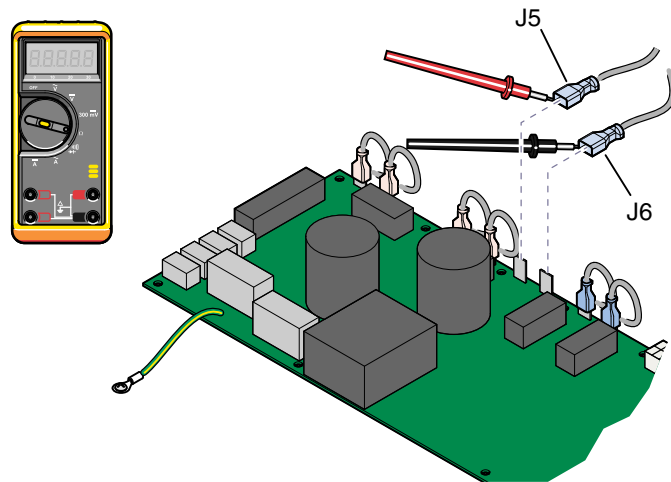

Actuator Motor Test

Step 2: Place meter probes on actuator wires. Check meter reading.

Meter Reading	Status	Required Action
1 to 10 Ω		Actuator motor - OK. Perform Motor Ground Test
OL -or- less than 1 Ω		Replace motor*.

Motor Ground Test

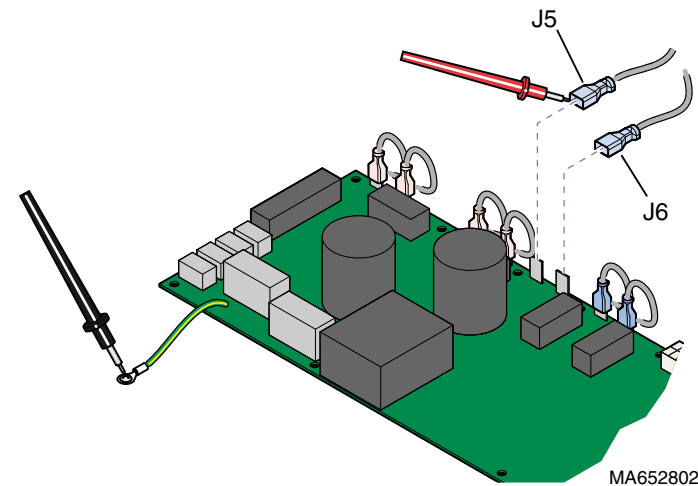

Motor Ground Test

Step 1: Place one meter probe on actuator wire (J5). Place other meter probe on PC board ground wire. Check meter reading. (Repeat for J6)

Meter Reading	Status	Required Action
OL -or- more than 1 M Ω		Motor harness - OK. Perform PC Board Test
less than 1 Ω		Replace motor*.

Foot Actuator

Page

Actuator Motor Test B-25

PC Board Test B-26

Actuator Replacement B-27

Wiring Diagrams D-1

Exploded View / Part Numbers:

Midmark models E-7

Ritter models E-8

Models:
Serial Numbers:

ALL

Foot Actuator

Component Testing & Repair

Foot Actuator - continued

PC Board Test

Refer To:	Page
PC Board Cover Removal:	
models w/ Standard Base	C-2
models w/Rotational Base	C-3
Base Shrouds:	
Raising (w/bungee cord)	C-4
Removal	C-5
Seat Section Covers	C-8

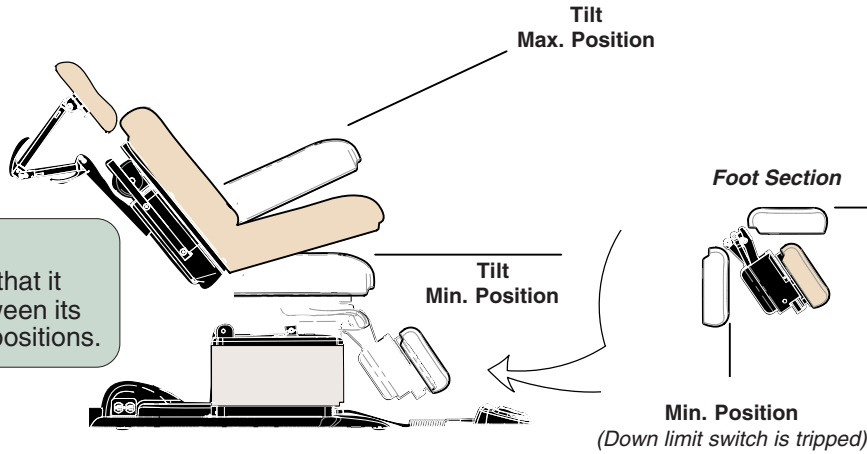

PC Board Test
Step 1: Move **TILT** function so that it is approx. halfway between its maximum & minimum positions.

PC Board Test
Step 2: This test **cannot** be performed if treatment pan is pulled out, or if either foot limit switch is tripped.
 If necessary, remove switch trigger bracket. Refer to: *Foot Section Covers* in Section C

PC Board Test
Step 3: Disconnect foot actuator wires from J5 & J6.

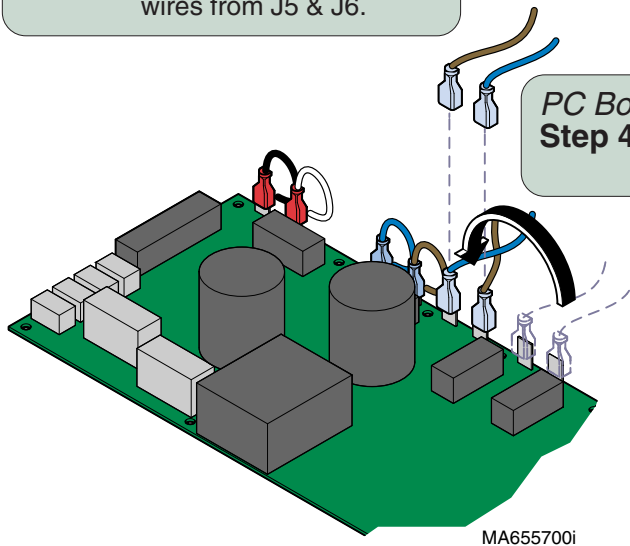

PC Board Test
Step 4: Move brown wire from J7 to J6. Move blue wire from J8 to J5.

Equipment Alert
 The tilt limit switches will not stop movement during this test.
Do not run past max. / min. positions.



PC Board Test
Step 5: Press & hold Foot Up button for 5 seconds.
 Does the **tilt function** move up, then stop & "beep"?
 If **YES**, go to Step 6.
 If **NO**, replace PC Board.

PC Board Test
Step 6: Press & hold Foot Down button for 5 seconds.
 Does the **tilt function** move down, then stop & "beep"?
 If **YES**, PC Board is OK.
 If **NO**, replace PC Board.

Foot Actuator - continued

Actuator Replacement

NOTE: Midmark table is shown. The procedure for Ritter tables is similar.

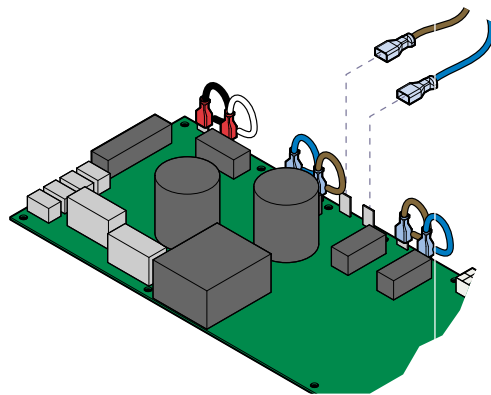

Removal

Step 1: Disconnect foot actuator wires from PC board. Pull actuator wire up thru table.

Note: Remove cable ties & wire clamps as necessary.

Installation

Step 3: Route actuator wire thru table. Connect actuator wires to PC board.
Midmark models: blue to J5 & brown to J6
Ritter models: black to J5 & white to J6

Note: Replace all cable ties & wire clamps.

Refer To:

Page

PC Board Cover Removal:

models w/ Standard Base C-2

models w/Rotational Base C-3

Base Shrouds:

Raising (w/bungee cord) C-4

Removal C-5

Seat Section Covers C-8

Foot Section Covers:

Midmark models C-7

Ritter models C-8

Removal

Step 3 : Remove clevis pin and actuator.

Installation

Step 1: Position actuator and install clevis pin & e-rings.

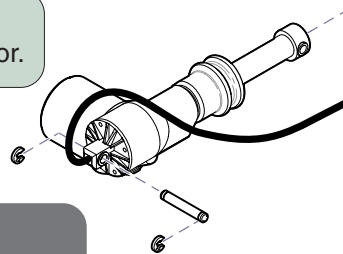

Removal

Step 2: Remove jam nuts and pivot screws.

Installation

Step 2: Install pivot screws & jam nuts.

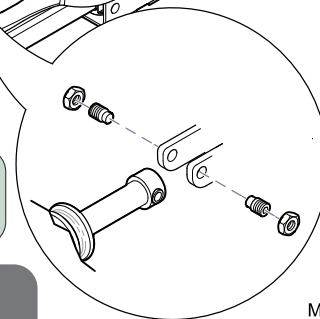
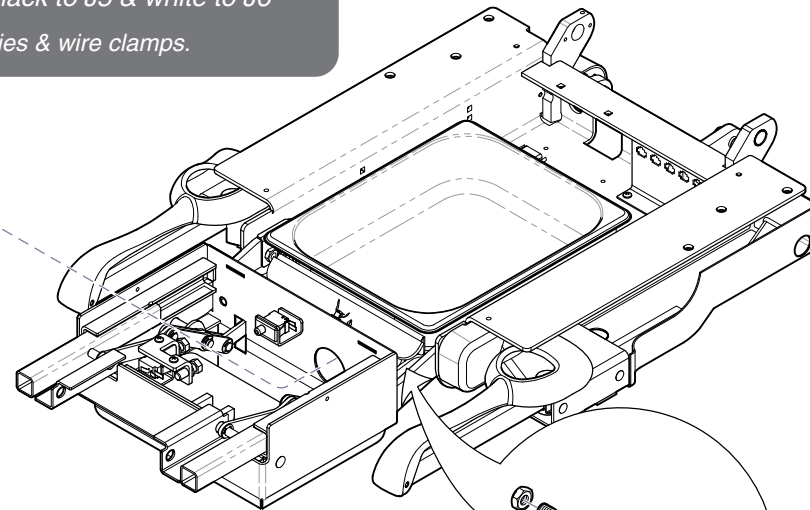

MA653600i

Models:
Serial Numbers:

ALL

Foot Actuator

Component Testing & Repair

Gas Springs

Replacement

Removal

Step 1: Run base function all the way up.

Gas Springs

Page

Replacement B-28

Base Shroud (Removal / Installation) ... C-5

Wiring Diagrams D-1

Exploded View / Part Numbers E-18

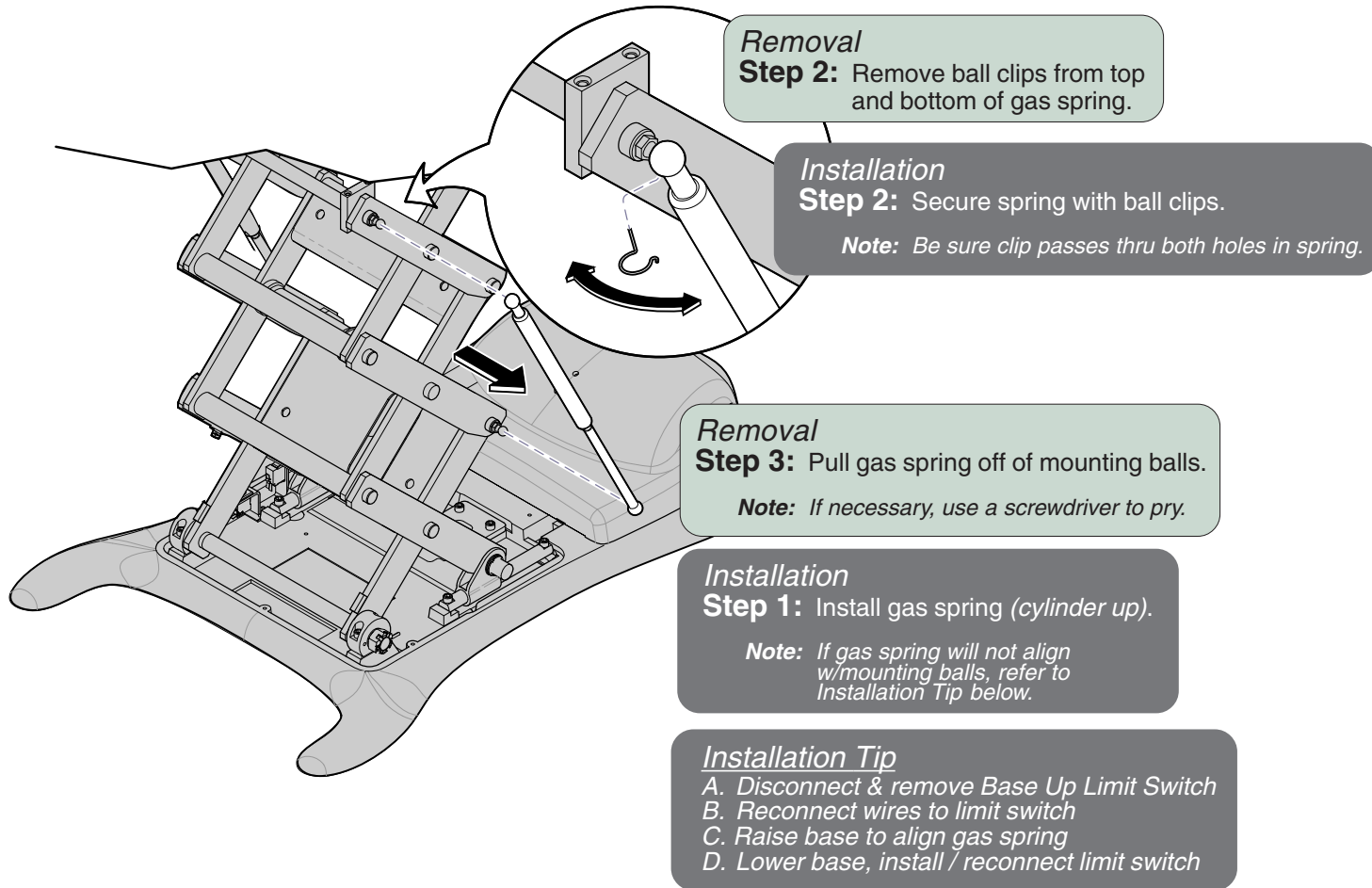

Component Testing & Repair

Isolation Transformer / Table Receptacles

[NOTE: This transformer affects table receptacles only].

Output Voltage Test

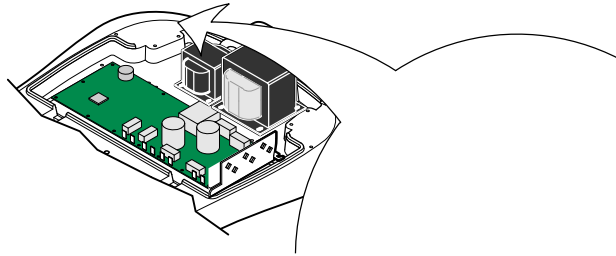

<u>Isolation Transformer</u>	<u>Page</u>
Output Voltage Test	B-29
PC Board Cover Removal:	
<i>models w/ Standard Base</i>	C-2
<i>models w/Rotational Base</i>	C-3
Wiring Diagrams	D-1
Exploded View / Part Numbers	E-26

Output Voltage Test
Step 1: Set meter to 200 VAC.

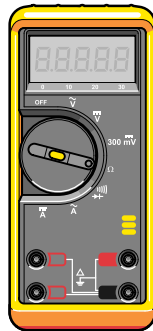

Output Voltage Test
Step 2: Place meter probes on receptacle screws (*top & bottom*). Check meter reading.

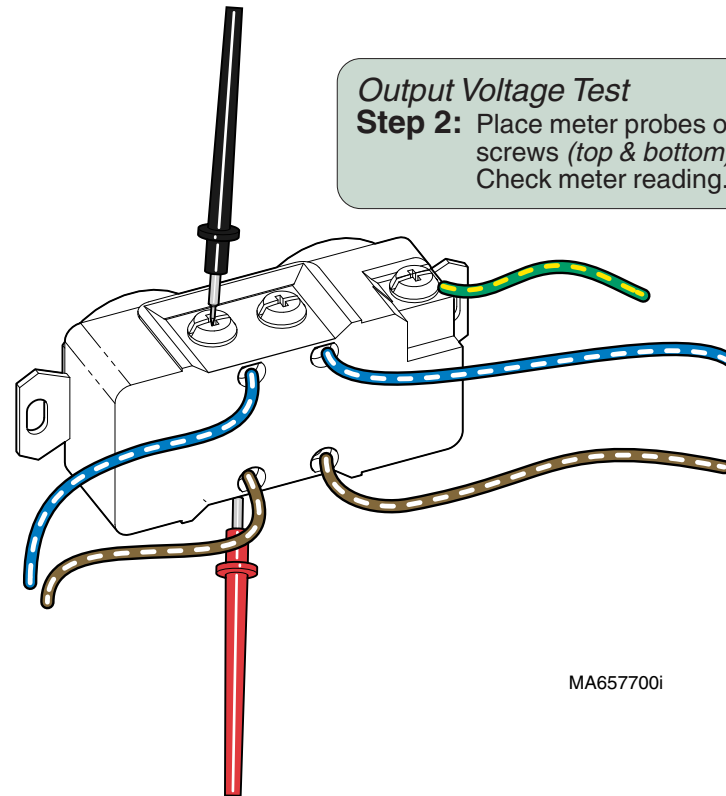

MA657700i

Meter Reading	Status	Required Action
120 (± 12) VAC		Transformer - OK Replace receptacle(s).
less than 108 VAC		If table power light is ON, replace transformer. If not, check supply voltage.

Models:	230 (-002)	630 (-003/-004/-008/-009)	75 (-020/-021)
Serial Numbers:	All	All	All

Isolation Transformer

Component Testing & Repair

Main System Transformer

[NOTE: This transformer affects all table functions (except table receptacles)].

Output Voltage Test

Main System Transformer	Page
Output Voltage Test	B-30
Resistance Test	B-31
PC Board Cover Removal:	
<i>models w/ Standard Base</i>	C-2
<i>models w/ Rotational Base</i>	C-3
Wiring Diagrams	D-1
Exploded View / Part Numbers	E-23

Output Voltage Test
Step 1: Set meter to 200 VAC.



Output Voltage Test
Step 3: Place meter probes on red and orange wires of transformer connector. Check meter reading.

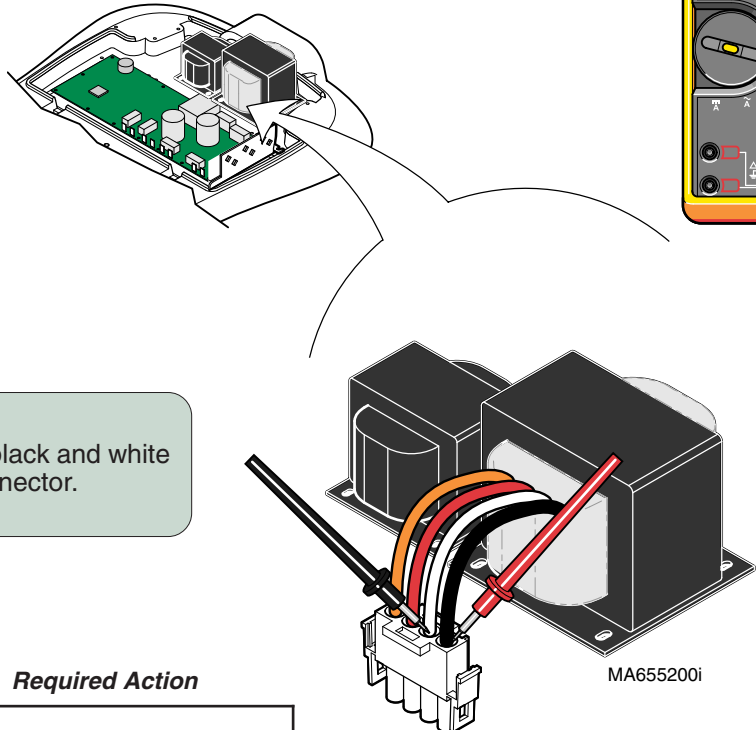

Output Voltage Test
Step 2: Place meter probes on black and white wires of transformer connector. Check meter reading.

[Black & White Wires] Meter Reading	Status	Required Action
42 to 58 VAC		Transformer - OK
less than 42 VAC more than 58 VAC		Perform Resistance Test

[Red & Orange Wires] Meter Reading	Status	Required Action
23 to 43 VAC		Transformer - OK
less than 23 VAC		Perform Resistance Test

Component Testing & Repair

Main System Transformer - continued

Resistance Test

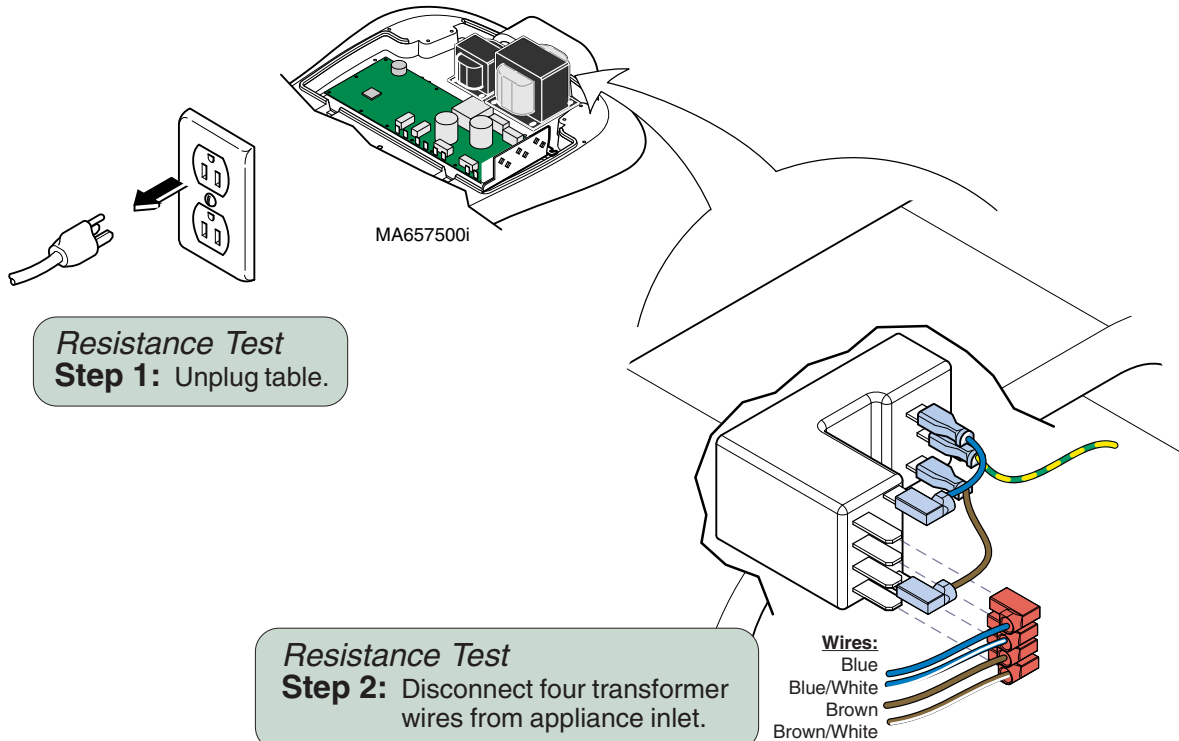

Resistance Test Step 2: Disconnect four transformer wires from appliance inlet.

Resistance Test Step 3: Set meter to 200 Ω .

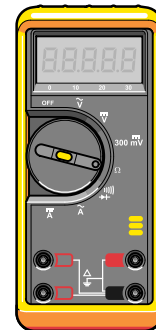

Meter Reading	Status	Required Action
less than 10 Ω		Transformer - OK
OL -or- more than 10 Ω		Replace transformer.

Resistance Test Step 5: Place meter probes on blue and brown wires. Check meter reading.

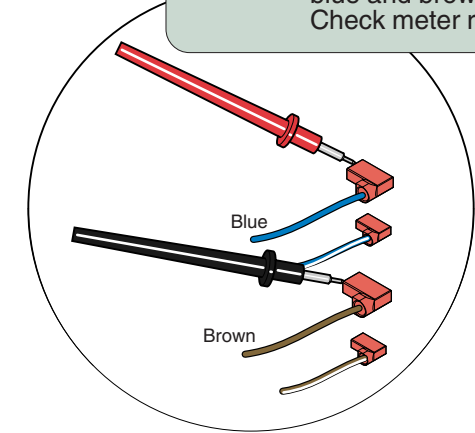

Resistance Test Step 4: Place meter probes on blue/white and brown/white wires. Check meter reading.

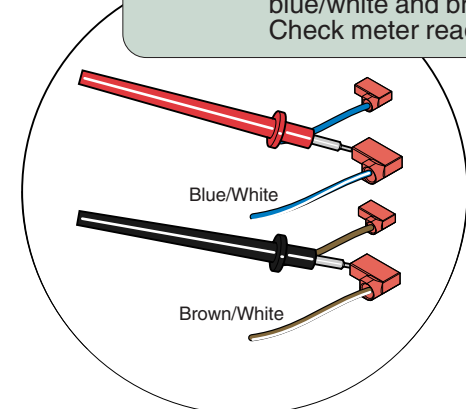

Models: | ALL
Serial Numbers:

Main System Transformer

Component Testing & Repair

Position Sensors

Testing

Step 1: Verify position sensor shoulder bolts are tight (50 ft-lbs).
Note: This step does not apply to the Base position sensor.

Step 2: Perform **Output Voltage Test (at Sensor)**.
Note: This test must *always* be performed first. The results from this test determine the next required action.

Position Sensors	Page
Testing	B-32
Location	B-32
Output Voltage Test (at Sensor)	B-33
Removal	B-37
Adjustment	B-38
Access Procedures	C-1
Wiring Diagrams	D-1
Exploded View / Part Numbers	E-25

Location

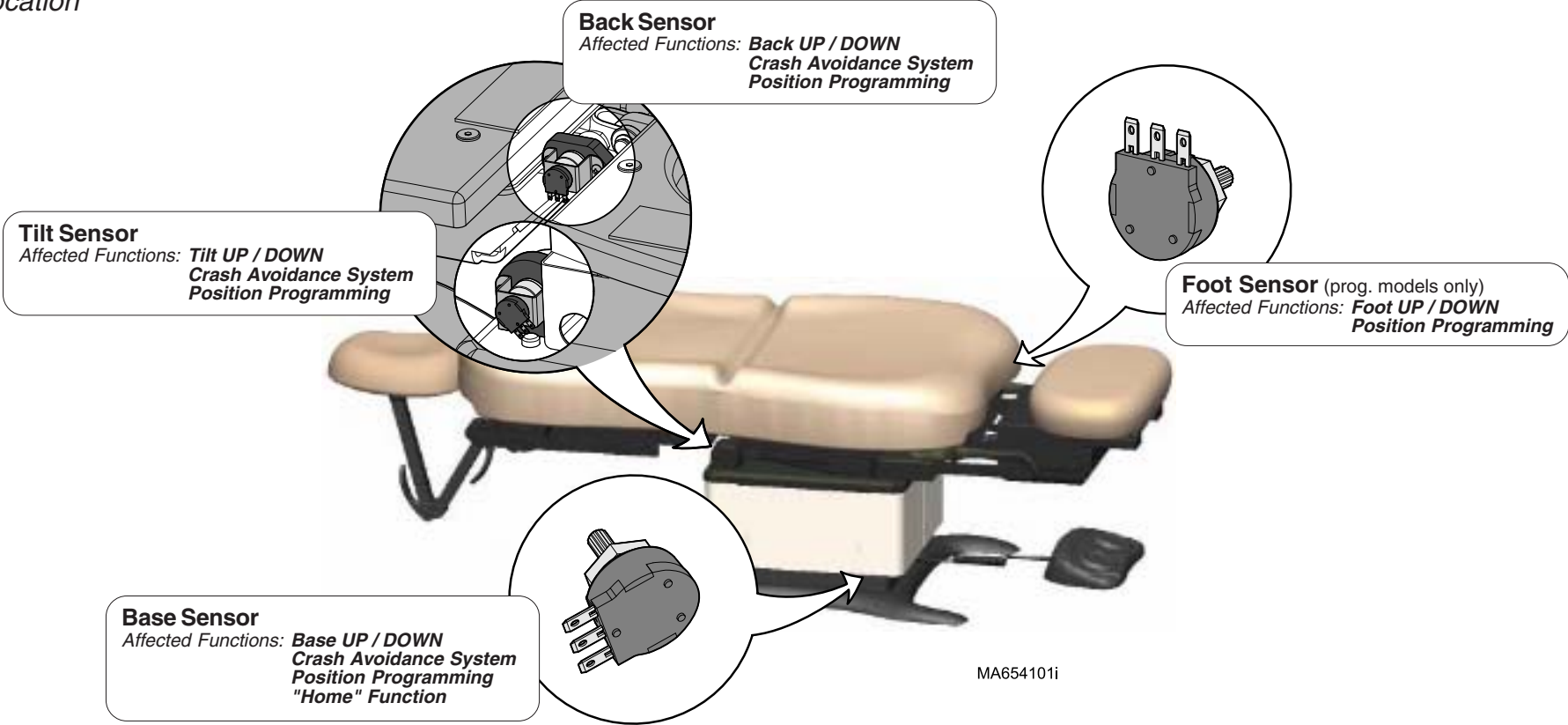

Position Sensors - continued

Output Voltage Test (at Sensor)

Go to:

Page

Output Voltage Test (at PC Board) B-34

Supply Voltage Test (at Sensor) B-35

Output Voltage Test

Step 1: Set meter to 20 VDC.

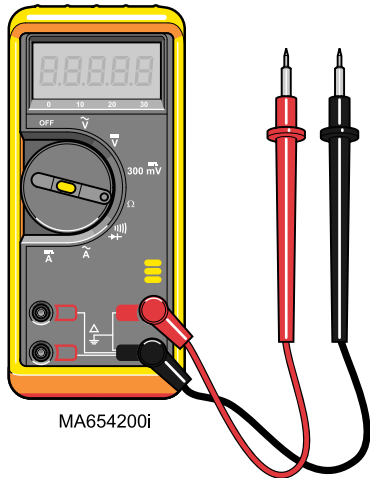

Output Voltage Test

Step 2: Place meter probes on proper terminals.
(See appropriate illustration)

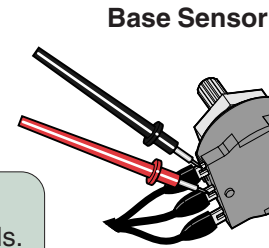

Base Sensor

Foot Sensor

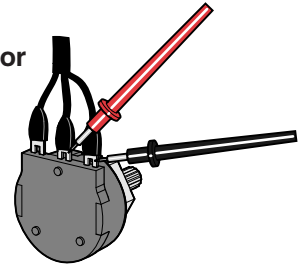

Tilt Sensor

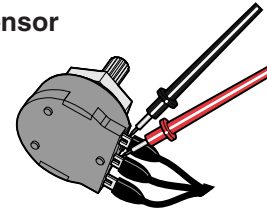

Back Sensor

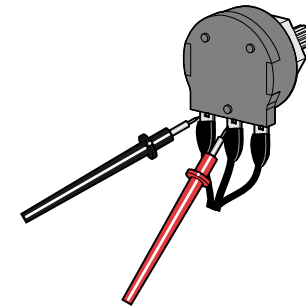

Output Voltage Test

Step 3: Run desired function up & down.
Watch meter reading as function moves.

Note: Each sensor has a different voltage range.

Meter Reading	Position Sensor Status	Required Action
Voltage steadily increases / decreases as function moves up / down		Perform Output Voltage Test (at PC Board)
Voltage does not change, or changes erratically as function moves up / down		Perform Supply Voltage Test (at Sensor)

Models:
Serial Numbers:

630 (all)
All

75 (-020/-021)
All

Position Sensors

Component Testing & Repair

Position Sensors - continued

Output Voltage Test (at PC Board)

Go to: [PC Board Replacement](#) **Page** B-44

Output Voltage Test
Step 1: Set meter to 20 VDC .

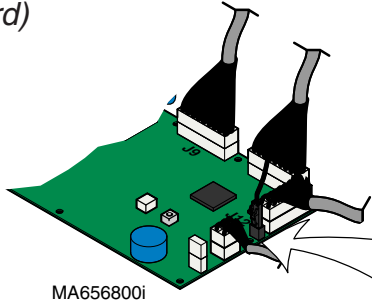
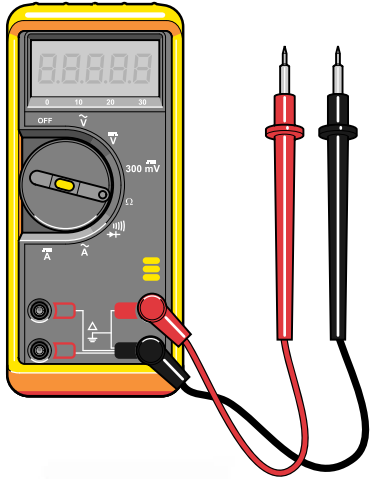

Output Voltage Test
Step 2: Place meter probes on proper wires.
(See appropriate illustration)

Output Voltage Test
Step 3: Run desired function up & down.
Watch meter reading as function moves.
Note: Each sensor has a different voltage range.

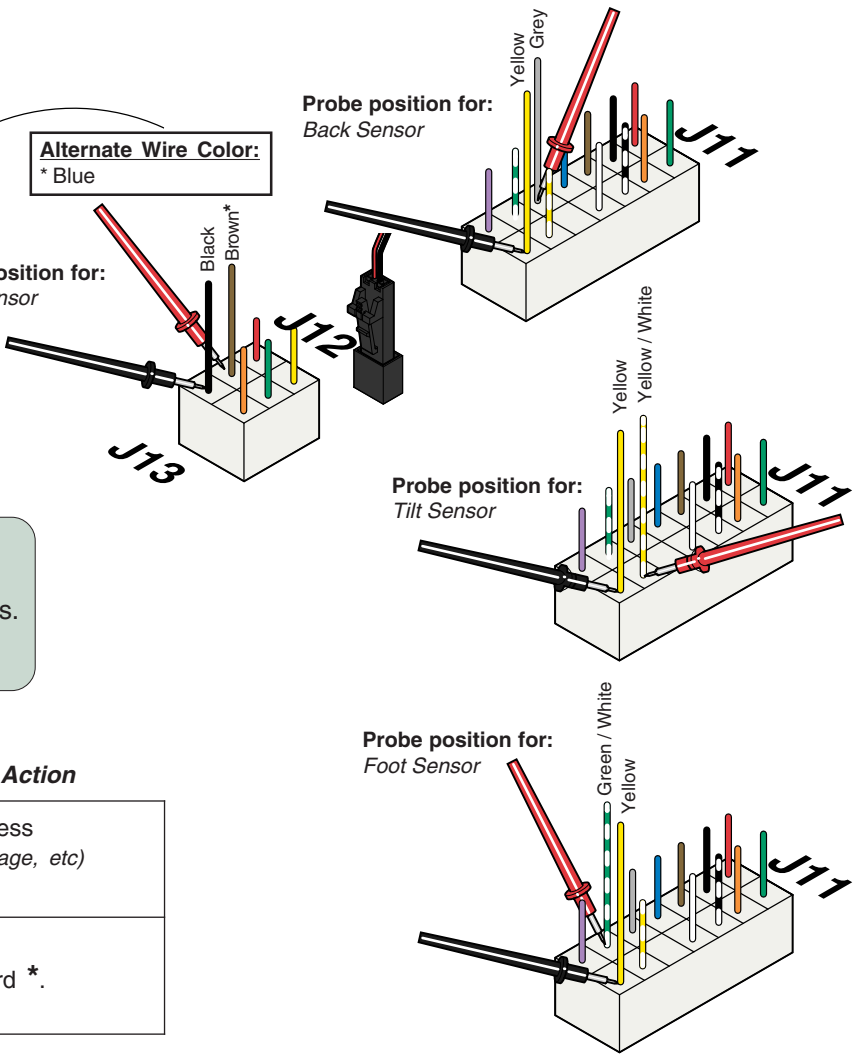

Meter Reading	PC Board Status	Required Action
Voltage does not change, or changes erratically as function moves up / down		Check wire harness (connections, damage, etc)
Voltage steadily increases / decreases as function moves up / down		Replace PC Board *.

* Before replacing PC board, be sure shoulder bolt at the position sensor pivot point is tight (and jam nut is in place). If bolt is loose, tighten it, then recalibrate PC board & check for proper operation.

Position Sensors - continued

Supply Voltage Test (at Sensor)

Go to: [Page](#)
Supply Voltage Test (at PC Board) B-36

Supply Voltage Test
Step 1: Set meter to 20 VDC.

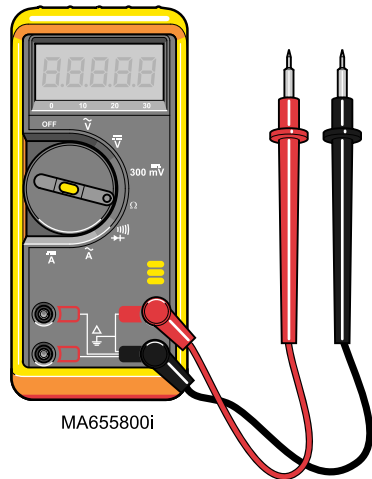

Supply Voltage Test
Step 2: Place meter probes on proper terminals.
(See appropriate illustration)

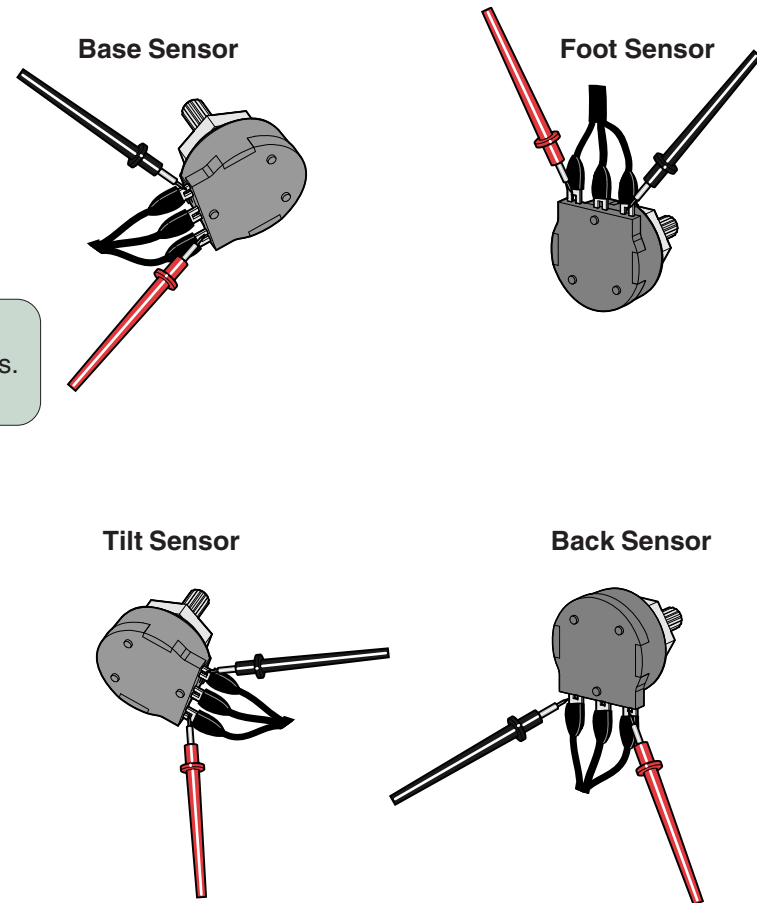

Meter Reading	Position Sensor Status	Required Action
2 to 4 VDC		1. Position Sensor Adjustment 2. Replace position sensor*.
less than 2 VDC more than 4 VDC		Perform Supply Voltage Test (at PC Board)
Reading changes erratically as BASE moves up / down		Perform Supply Voltage Test (at PC Board)

Models:
Serial Numbers:

630 (all)
All

75 (-020/-021)
All

Position Sensors

Component Testing & Repair

Position Sensors - continued

Supply Voltage Test (at PC Board)

Go to: **Page**
 PC Board Replacement B-44

Supply Voltage Test
Step 1: Set meter to 20 VDC .

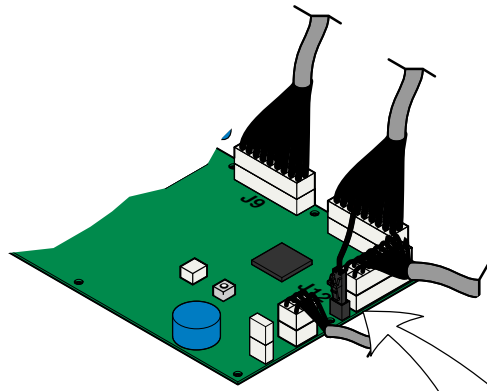
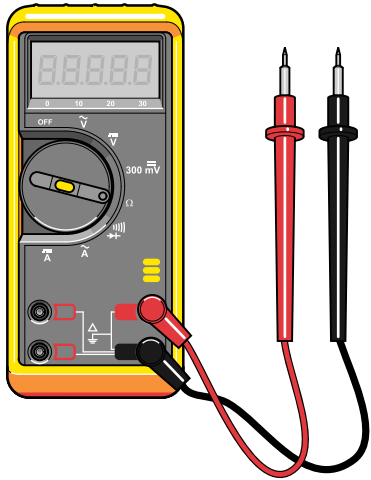

MA654700i

Supply Voltage Test
Step 2: Place meter probes on proper wires.
 (See appropriate illustration)

*** Attention (Back / Tilt / Foot only)**
 If initial reading is less than 2VDC or more than 4VDC, unplug J11 connector & check meter reading at pins on PC board (same location).
 If reading is:
 2 to 4 VDC Replace sensor wire harness.
 < 2 VDC Replace PC board.
 > 4 VDC Replace PC board

Probe position for:
 Back Sensor*
 Tilt Sensor*
 Foot Sensor*

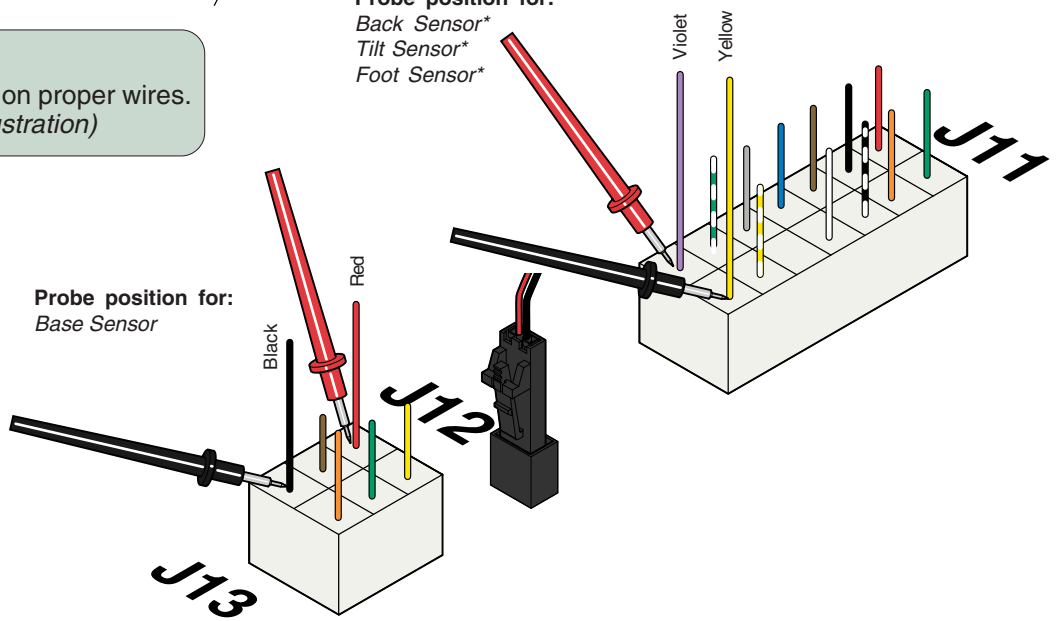

Probe position for:
 Base Sensor

Meter Reading	PC Board Status	Required Action
2 to 4 VDC		Replace wire harness between: (sensor & junction board) - or (junction board & PC board)
less than 2 VDC more than 4 VDC		Replace PC board*.

Position Sensors - continued

Adjustment

NOTE: Complete replacement instructions are supplied with the sensor kit. They are also available on Midmark.com, or by clicking on the blue link.



Adjustment

Step 1: Move the corresponding function as indicated below:

BASE / BACK / FOOT: all the way UP

TILT: all the way DOWN

Example: If changing back sensor, press Back Up button until back section is all the way up.

Base Sensor Bracket

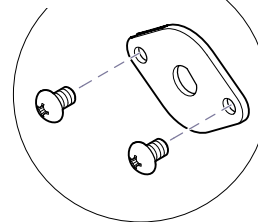

(Old-style brackets shown)

Adjustment

Step 2: Remove sensor cover (or shrouds for base sensor).

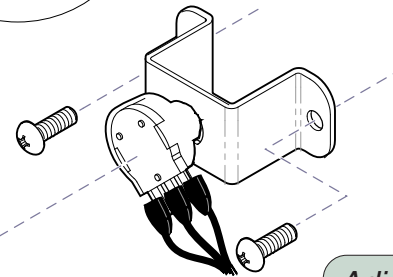
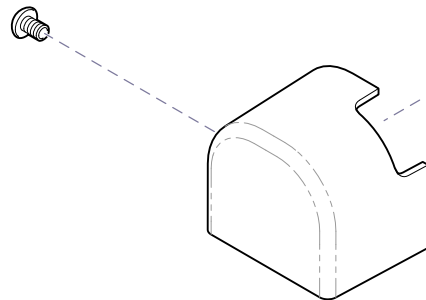

Adjustment

Step 3: Separate bracket / sensor from chair.

MA657101i

Models:
Serial Numbers:

630 (all)
All

75 (-020/-021)
All

Position Sensors

B-37

Component Testing & Repair

Position Sensors - continued

Adjustment

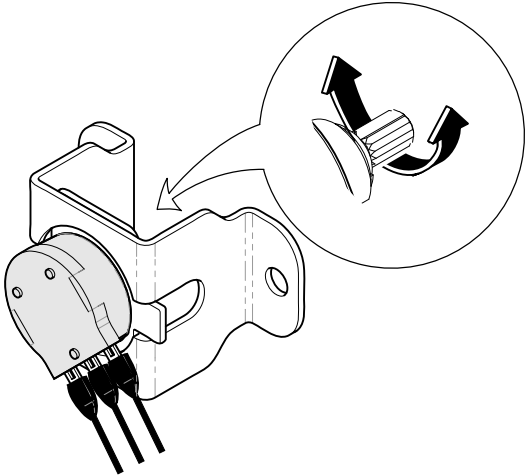

Adjustment

Step 5: Turn sensor knob until voltage reading is in the indicated range.

SENSOR	FUNCTION POSITION	VOLTAGE READING
BASE	all the way UP	1.7 to 2.1 VDC
BACK	all the way UP	2.4 to 2.6 VDC
TILT	all the way DOWN	1.8 to 2.1 VDC
FOOT	all the way UP	2.4 to 2.6 VDC

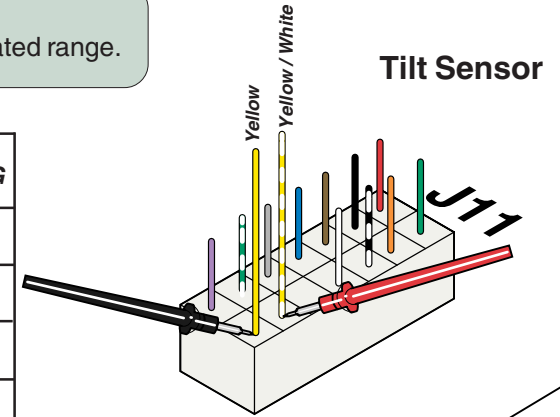

Adjustment

Step 4: Remove main PC board cover. Place meter probes as shown to test desired sensor.

Base Sensor

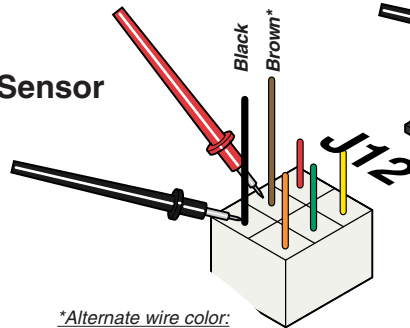

*Alternate wire color:
Blue

Back Sensor

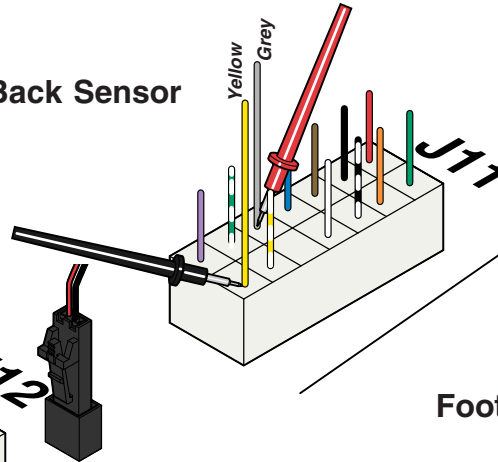

Foot Sensor

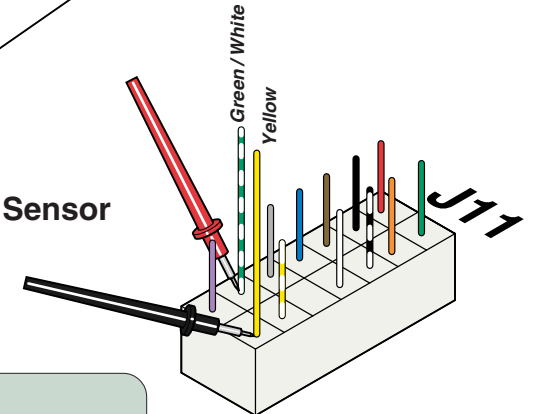

Adjustment

Step 6: Perform PC Board Calibration. [Refer to PC Board in Section B].

MA8060i

This page intentionally blank.

Component Testing & Repair

Main PC Board

Error Codes

If the PC Board detects a malfunction in the electrical system, the two Error Code LEDs on the PC Board will flash in a specific sequence to identify the cause of the problem.

How to Display an Error Code

If you suspect a problem with a specific function...

- Remove PC Board cover / locate Error Code LEDs
- Press hand/foot control button for desired function.

If an electrical malfunction is detected:

- Function will stop moving.
- You will hear a "beep".
- Error Code LEDs will flash error code sequence.

How to Recall Last Five Error Codes

To recall the last five error codes ...

- Move both MODE SELECT switches to ON (up).
- Unplug table (to reset PC Board), then plug back in.
- Press and release S2 Button.
(To repeat error codes, press S2 Button again)
(To erase all error codes from memory, press & hold S2 Button until you hear three "beeps")

If there are error codes stored in the system memory:

- Error Code LEDs will flash the sequence of the five most recent error codes.
(You will hear three "beeps" between each error code)

Main PC Board

Page

Error Codes:

How To Display / Recall Last Five Error Codes	B-40
Identification (Error Code Charts)	B-41
Calibration Procedure	B-42
Child Lock-Out Mode	B-43
Replacement	B-44
PC Board Cover Removal / Installation:	
models w/ Standard Base	C-2
models w/Rotational Base	C-3
Wiring Diagrams	D-1
Exploded Views / Part Numbers	E-23

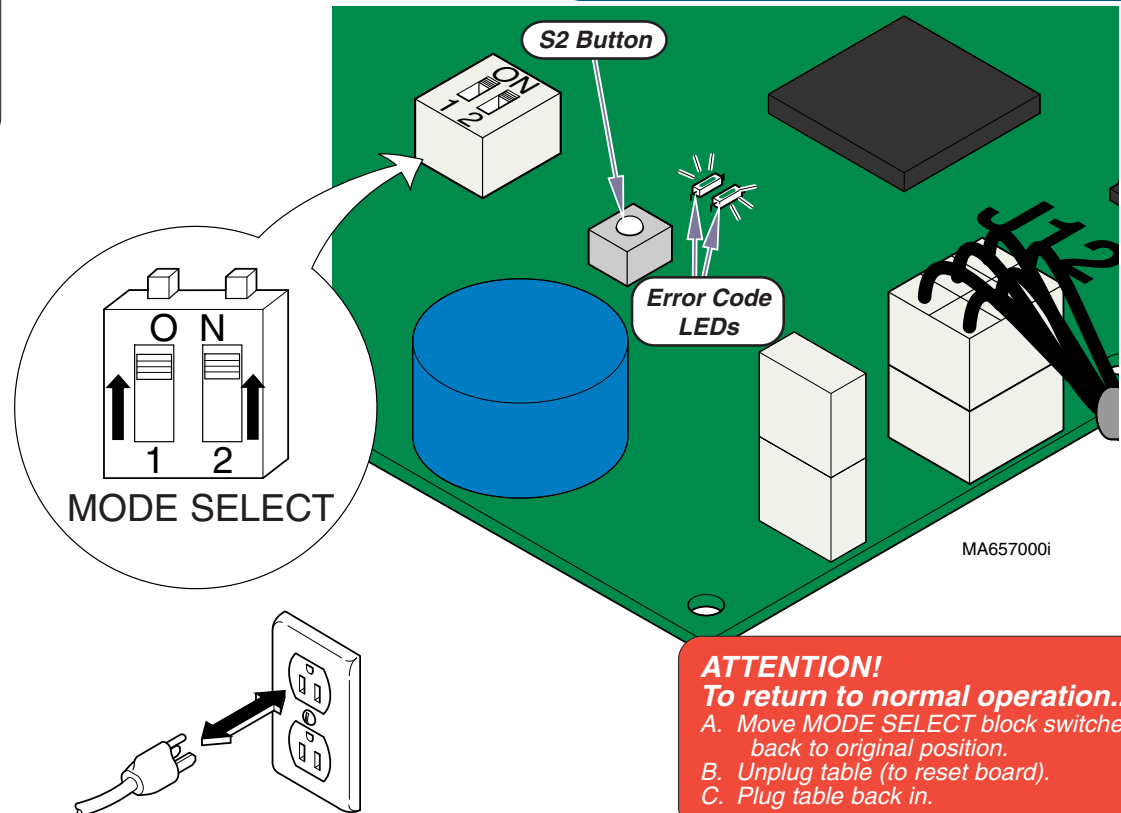

ATTENTION!
To return to normal operation...
A. Move MODE SELECT block switches back to original position.
B. Unplug table (to reset board).
C. Plug table back in.

Component Testing & Repair

Main PC Board - continued

Error Codes - continued

Identification

Digit 1 LED: This LED identifies the function or mode during which the error was detected. (ex. Base / Back / Tilt / Foot, Programming Mode, Calibration Mode, Software System)
Record the number of times this LED flashes before Digit 2 LED begins to flash.

Digit 2 LED: This LED identifies cause of the error. (ex. actuator motor overload, treatment pan out, etc.)
Record the number of times this LED flashes before Digit 1 LED flashes again.

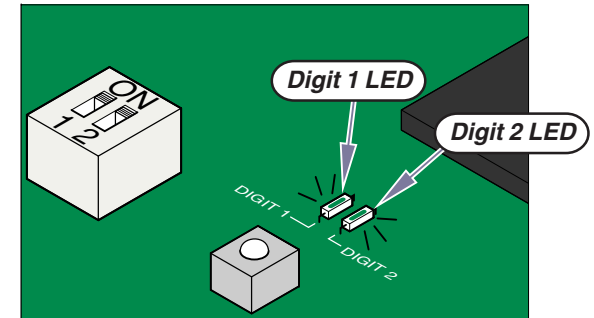

MA657200i

Locate the two digit error code in the charts below:

(# of flashes) Digit 1 LED	Table Function	(# of flashes) Digit 2 LED	Cause of the Error
1	BASE	1	Function in potential crash position
2	BACK	2	Actuator motor run time exceeded max. limit
3	TILT	3	Position sensor did not move when function was activated
4	FOOT	4	Position sensor reading is out of acceptable range
5	(not used)	5	Actuator motor overload
6	(not used)	6	Function failed during calibration
7	Programming Mode	1	Position Button (1,2,3, or 4) not pressed within 5 seconds.
		2	Incorrect button pressed while in Programming Mode.
		3	Position cannot be programmed (possible "crash" position)

(# of flashes) Digit 1 LED	Table Function	(# of flashes) Digit 2 LED	Cause of the Error
8	Calibration Mode	1	Calibration was not successful
		2	Incorrect button pressed while in Calibration Mode.
	Error Recall Mode	3	Incorrect button pressed while in Error Recall Mode.
9	Software System	1	Software malfunction
		2	Software malfunction
		3	Software malfunction
		4	Foot UP function activated w/ Treatment Pan pulled out
		5	Hand/foot control button pressed while in Child Lock-Out Mode
		9	Disregard this error.

Models:
Serial Numbers:

ALL

Main PC Board

B-41

Component Testing & Repair

Main PC Board - continued

Calibration Procedure

During the Calibration Procedure, the PC Board records the voltage readings from the position sensors as all of the table functions (*base, back, tilt, foot*) move to their maximum, then minimum positions. You will hear a steady pattern of "beeps" as the table moves during calibration. When successful calibration is complete, the table will stop moving and you will hear three "beeps".

You **must** calibrate the PC Board in the following situations:

- After replacing the PC Board
- After replacing any of the position sensors
- After any of the position sensors are removed or disconnected

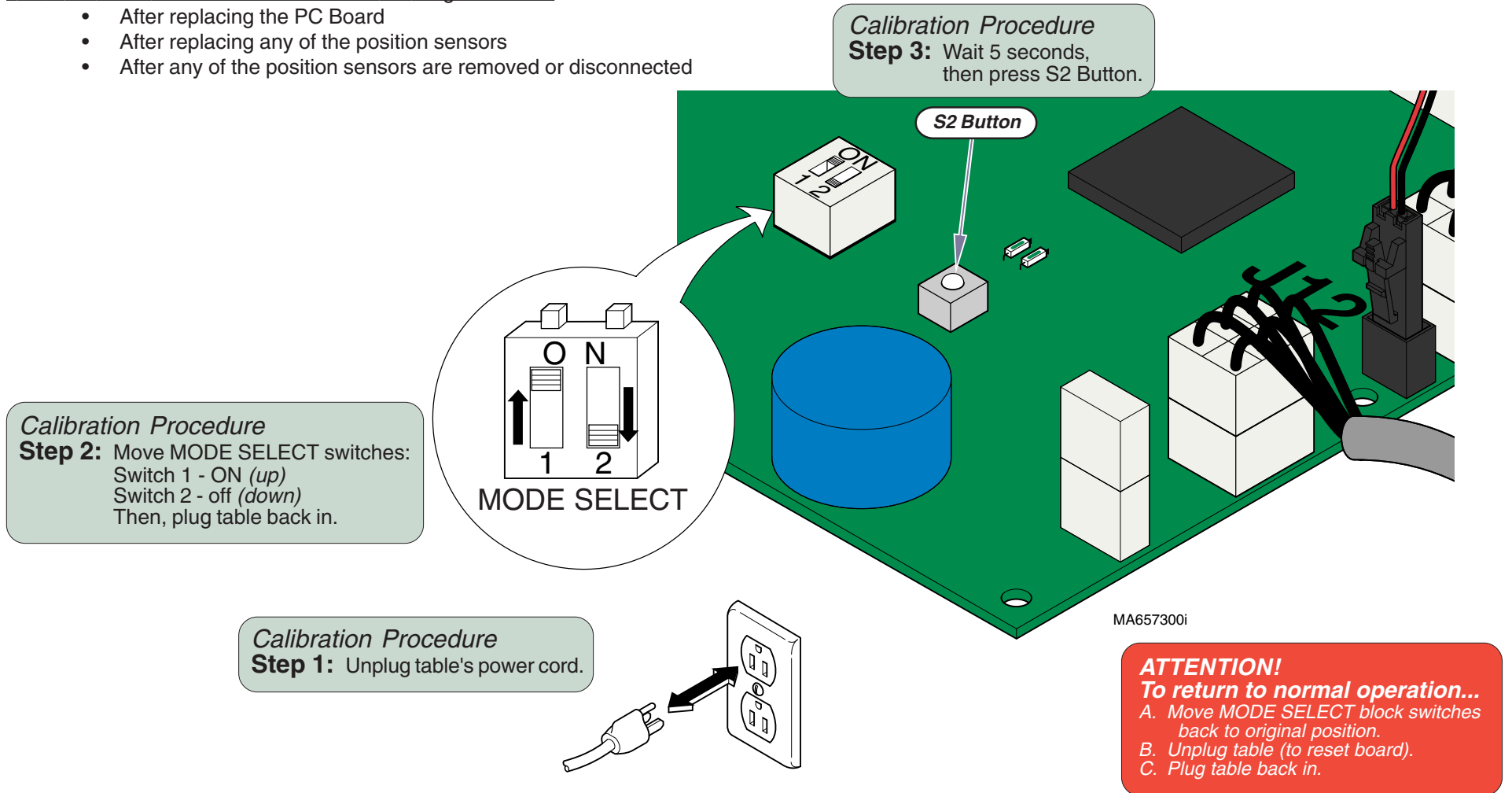

Component Testing & Repair

Main PC Board - continued

Child Lock-Out Mode (Programmable models only)

This feature allows the user to lock-out the hand & foot controls to prevent unauthorized use.

[NOTE: When the table is in Child Lock-Out Mode, the Position "4" button cannot be used to store a programmed position.]

Child Lock-Out Mode
Step 1: Move MODE SELECT switches:
Switch 1 - off (down)
Switch 2 - ON (up)

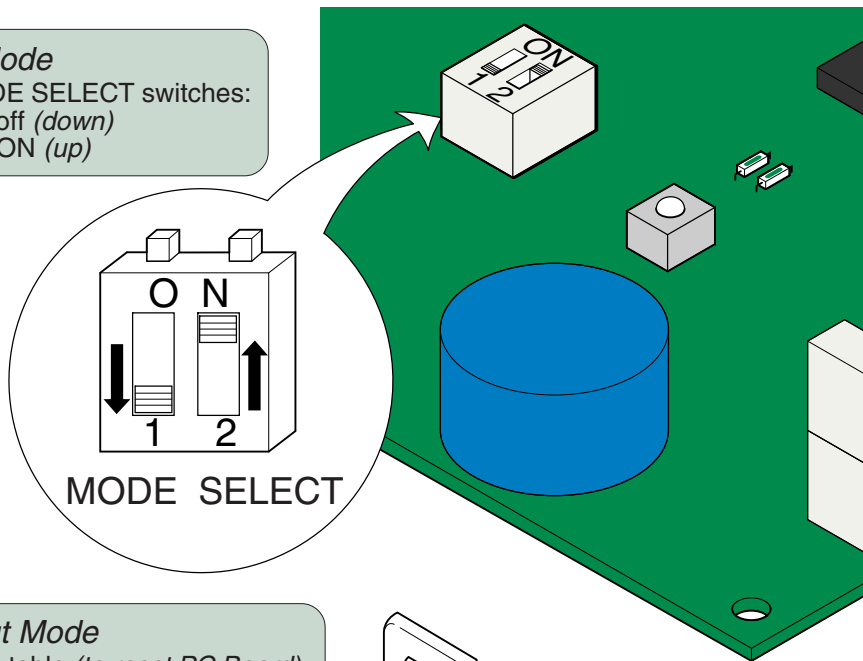

Child Lock-Out Mode
Step 2: Unplug table (to reset PC Board),
then plug table back in.

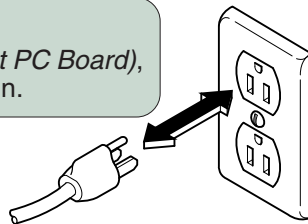

MA657400i

Child Lock-Out Mode

Step 3: To lock hand / foot controls...

Press & hold "4" button on hand / foot control.
(After 5 seconds you will hear a "beep".
This indicates the controls are locked)

Note: If a button is pressed while controls are locked,
you will hear a "beep".

To unlock hand / foot controls...

Press & hold "4" button on hand / foot control.
(After 5 seconds you will hear a "beep".
This indicates the controls are unlocked)

Position "4" Button



To deactivate Child Lock-Out Mode...

- Move MODE SELECT switches:
Switches 1 & 2 - off (down).
- Unplug table (to reset board).
- Plug table back in.

Models: | 630 (-002 / -004 / -006 / -007 / -009)
Serial Numbers: | All

75 (-021)
All

Main PC Board

B-43

Component Testing & Repair

Main PC Board - continued

Replacement

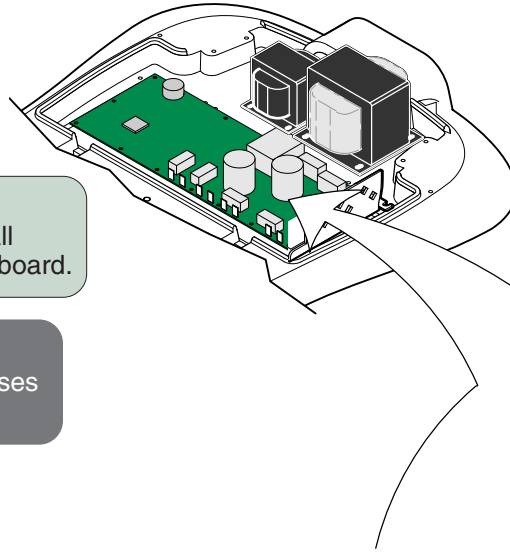

Removal

Step 1: Tag and disconnect all wire harnesses from board.

Installation

Step 2: Connect all wire harnesses to proper terminals.

Removal

Step 2: Push tabs back and remove board from mounting studs.

Installation

Step 1: Align board with mounting studs, then press down until tabs lock board in place.

Note: To minimize stress on the board, work from one end to the other.

Installation

Midmark models only!

Step 3: Perform **Calibration Procedure**.

Note: This must be performed any time PC Board is disconnected.

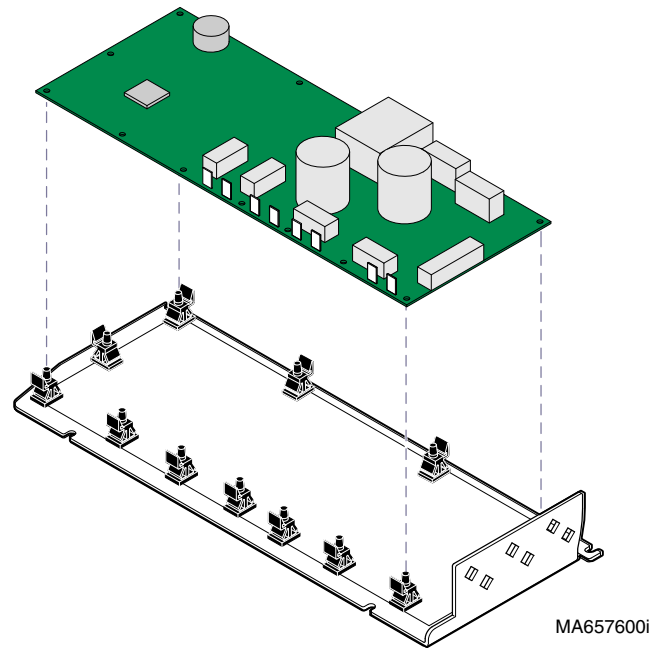

Upholstery Heater System

Use the table below to determine the required action.

<i>Problem</i>	<i>Required Action</i>
Upholstery heater does not warm up. Heater light does <u>not</u> illuminate	Perform <i>Upholstery PC Board Test</i>
Upholstery heater does not warm up. Heater light illuminates.	Perform <i>Upholstery Heater Test</i>
Upholstery heater - OK Heater light does <u>not</u> illuminate	Check wire connections. Replace heater light.

Upholstery Heater System	Page
Adjusting the Temperature	B-45
Upholstery Heater PC Board Test:	
<i>Output Voltage Test</i>	B-46
<i>Supply Voltage Test</i>	B-47
Upholstery Heater Test	B-48
PC Board Replacement	B-49
PC Board Cover Removal:	
<i>models w/ Standard Base</i>	C-2
<i>models w/Rotational Base</i>	C-3
Wiring Diagrams	D-1
Part Numbers	E-28

Adjusting the Temperature

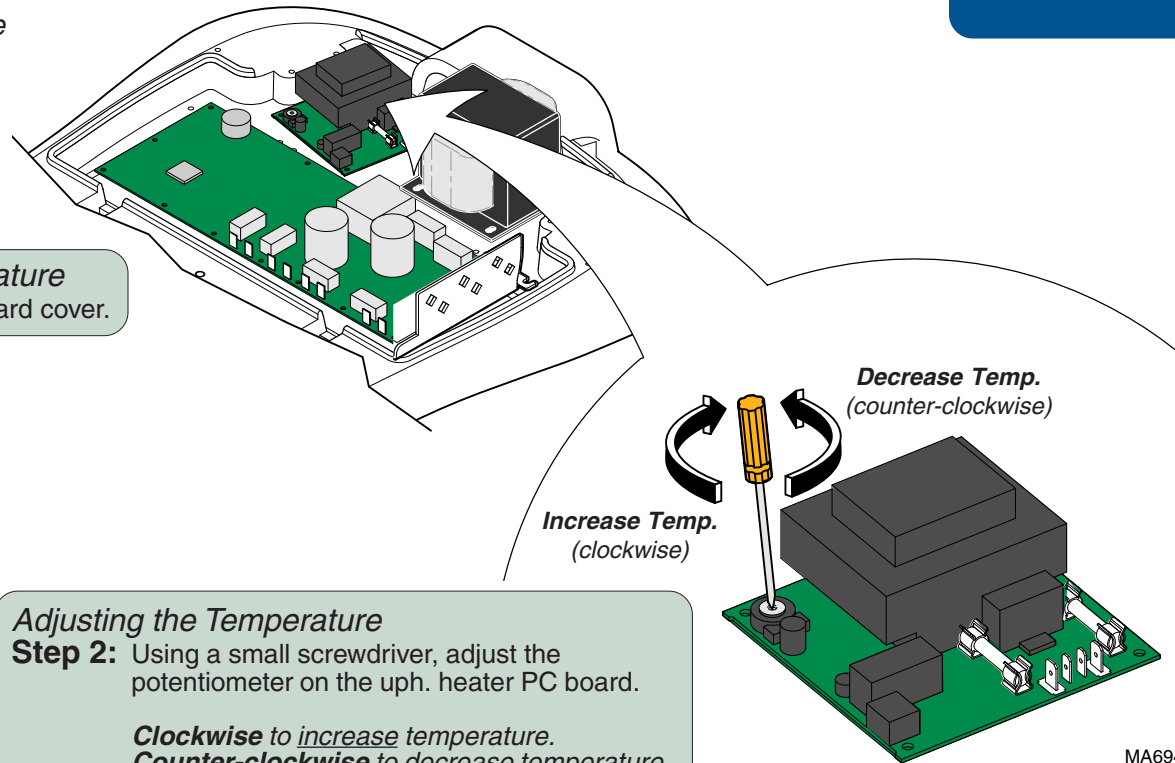

Adjusting the Temperature
Step 1: Remove PC board cover.

Adjusting the Temperature
Step 2: Using a small screwdriver, adjust the potentiometer on the uph. heater PC board.

Clockwise to increase temperature.
Counter-clockwise to decrease temperature.

MA694900i

Models: 630 (-007)
Serial Numbers: All

Upholstery Heater

Component Testing & Repair

Upholstery Heater System - continued

Upholstery Heater PC Board Test

(Outlook Voltage Test)

Output Voltage Test

Step 1: Disconnect upholstery heater wires.

Output Voltage Test

Step 2: Set meter to 20 VAC.



Output Voltage Test

Step 3: Place meter probes on wire from uph. heater PC board.

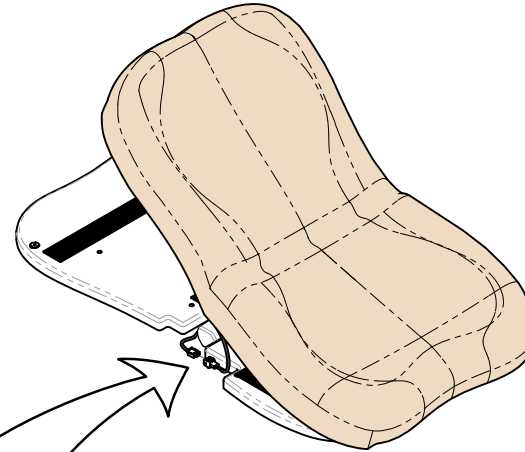
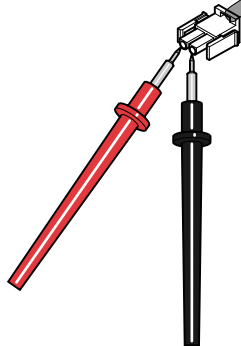

Output Voltage Test

Step 4: Turn upholstery heater ON.

Meter Reading	Status	Required Action
0 VAC		Check supply voltage to heater PC board
14 VAC + /- 3 VAC		Check upholstery heater

Component Testing & Repair

Upholstery Heater System - continued

Upholstery Heater PC Board Test - continued

(Supply Voltage Test)

Refer To:

Page

PC Board Cover Removal:

models w/ Standard Base C-2

models w/Rotational Base C-3



Caution

The power cord must be plugged in when performing this test.

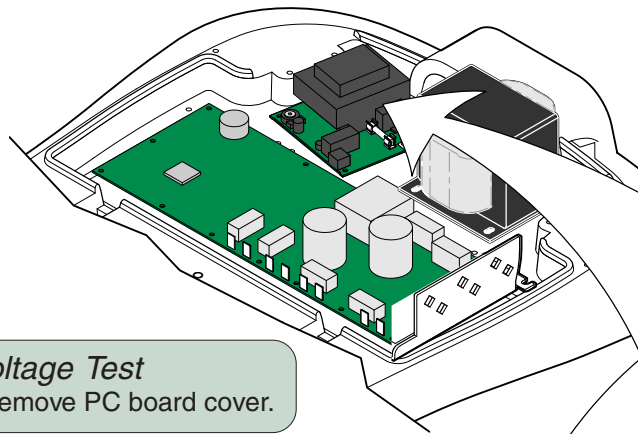

Supply Voltage Test
Step 1: Remove PC board cover.

Supply Voltage Test
Step 2: Set meter to 200 VAC.



Meter Reading	Status	Required Action
0 VAC		Check incoming power supply to the table.
115 VAC		Check wire connections & fuses on uph. heater PCB.

Supply Voltage Test
Step 3: With wires & power cord connected, place meter probes on J2 & J3 terminals on upholstery heater PC board.

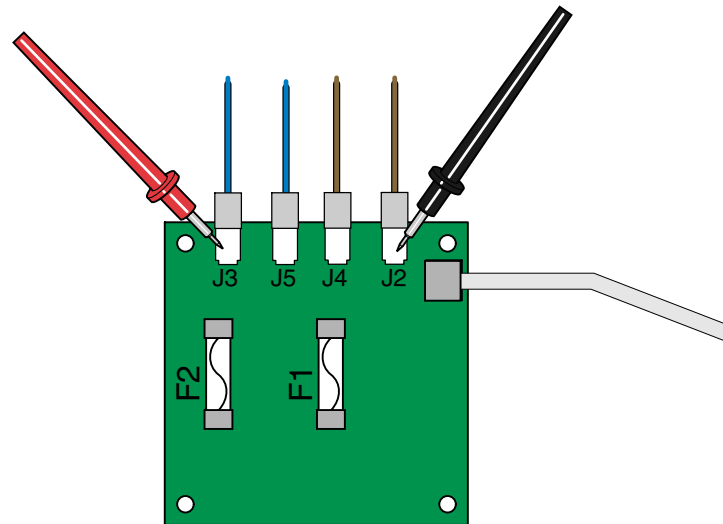

MA694800i

Models: 630 (-007)
Serial Numbers: All

Upholstery Heater

Component Testing & Repair

Upholstery Heater System - continued

Upholstery Heater Test

Upholstery Heater Test

Step 1: Disconnect upholstery heater wires.

Upholstery Heater Test

Step 2: Set meter to 200 Ω .

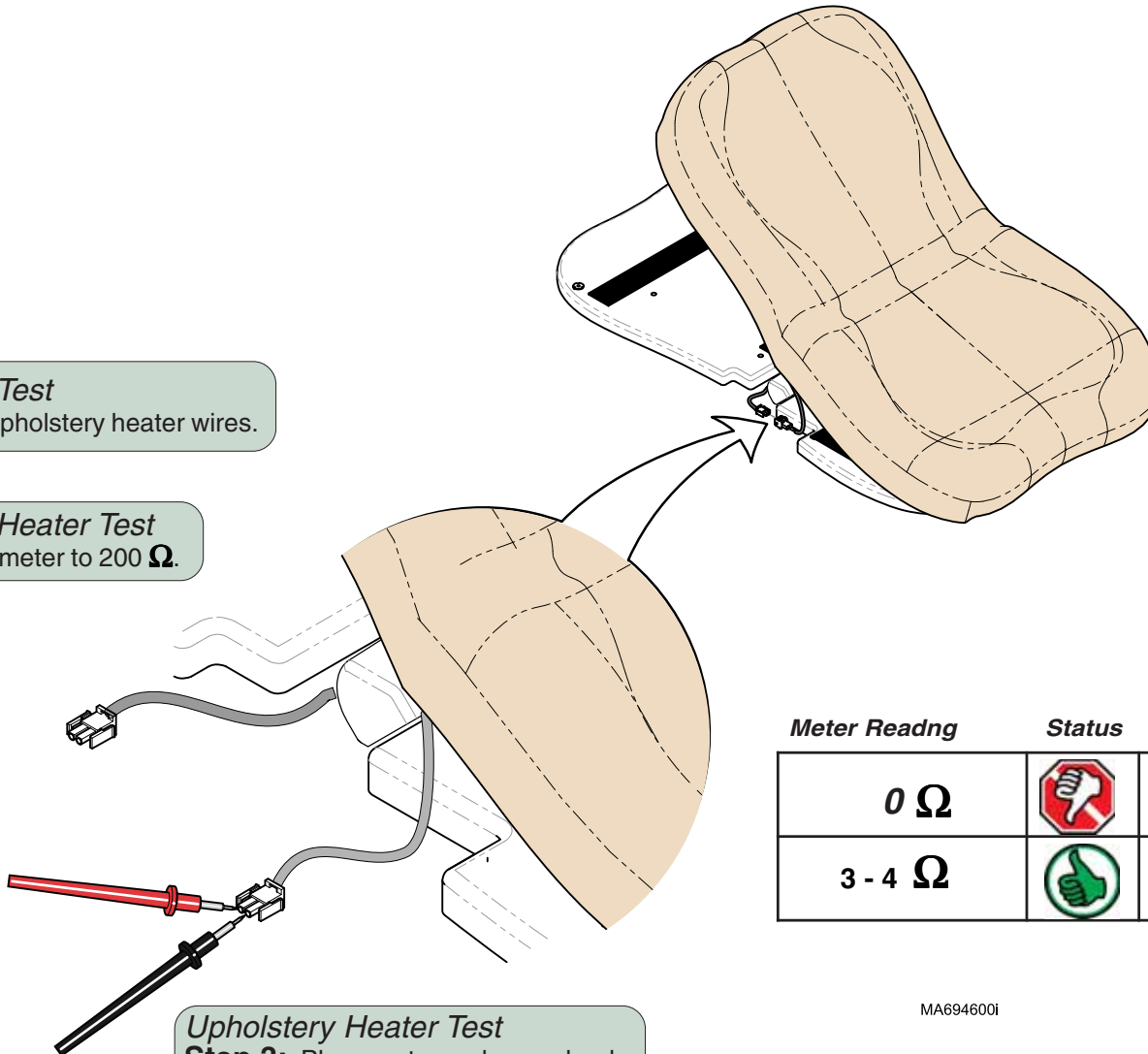

Upholstery Heater Test

Step 3: Place meter probes on leads from upholstery heater.

Meter Reading	Status	Required Action
0 Ω		Replace Upholstery
3 - 4 Ω		Check hand control. (Upholstery Heater button)

MA694600i

Upholstery Heater System - continued

Upholstery Heater PC Board Replacement

Removal

Step 1: Remove PC board cover.

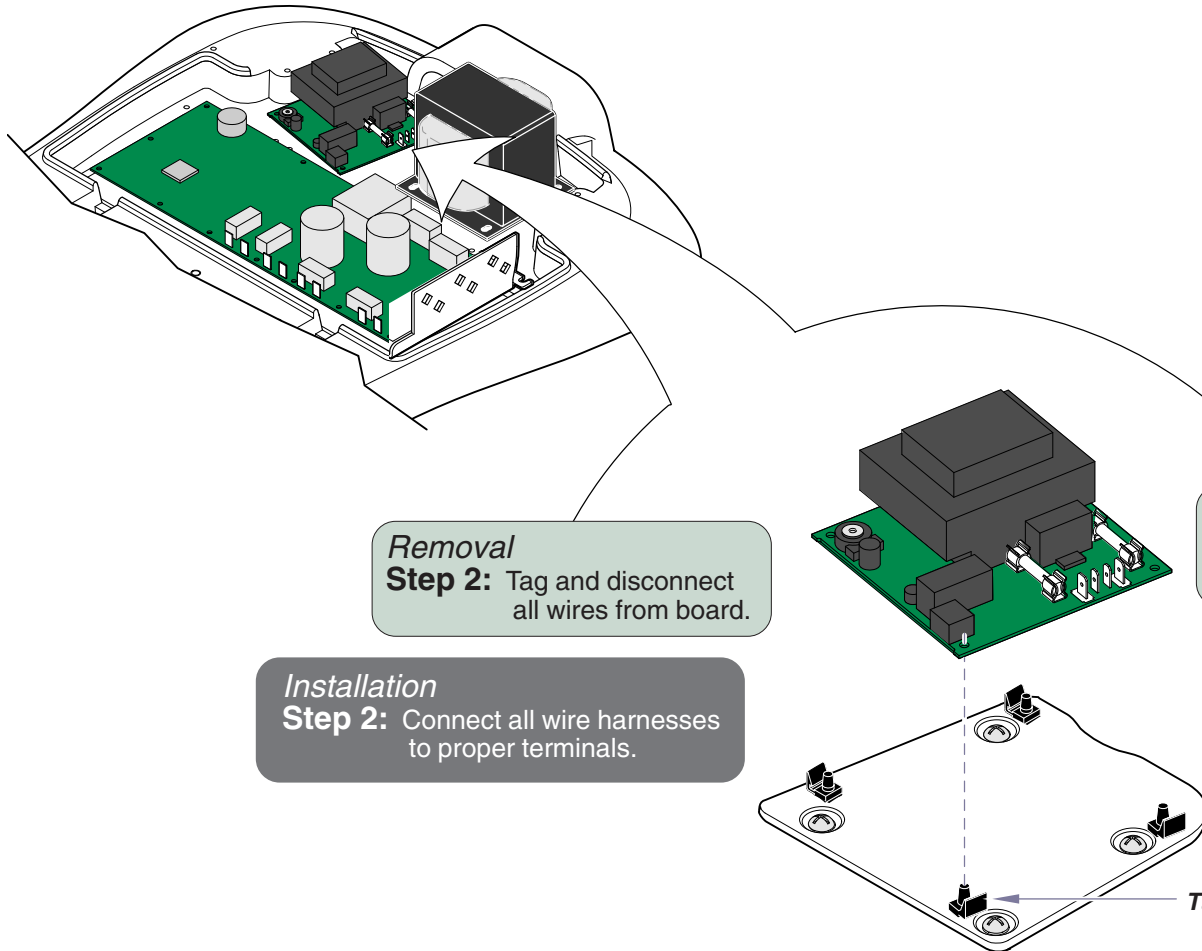

Removal

Step 2: Tag and disconnect all wires from board.

Installation

Step 2: Connect all wire harnesses to proper terminals.

Removal

Step 3: Push tabs back and remove board from mounting studs.

Installation

Step 1: Align board with mounting studs, then press down until tabs lock board in place.

Note: To minimize stress on the board, work from one end to the other.

MA694800i

Models:
Serial Numbers:

630 (-007)
All

Upholstery Heater

Component Testing & Repair

Headrest Mechanism

Handle Tension Adjustment

Headrest MechanismPage
Handle Tension Adjustment B-50
Exploded View / Part Numbers E-13

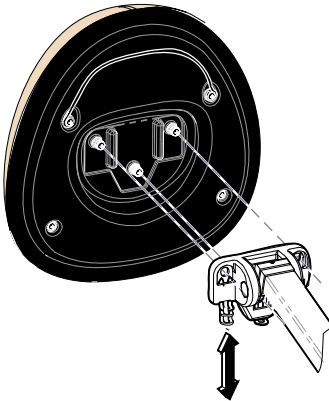

To adjust upper handle tension...
A. Loosen set screw.
B. Loosen / tighten adjustment screw.
C. Test upper handle for desired tension.
D. Tighten set screw when finished.

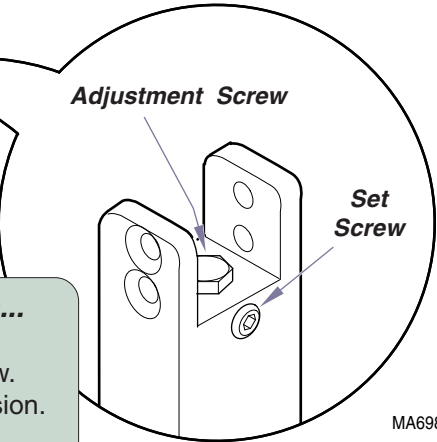
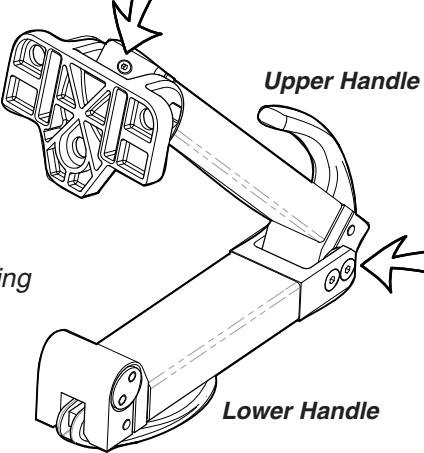
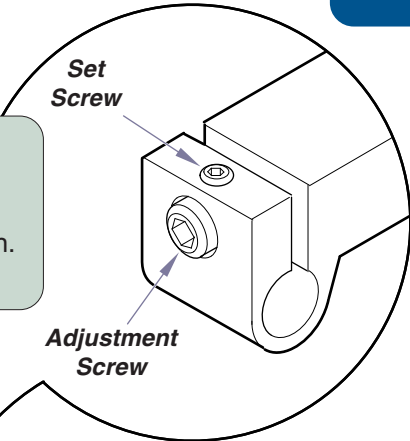

To adjust lower handle tension...
A. Loosen set screw.
B. Loosen / tighten adjustment screw.
C. Test lower handle for desired tension.
D. Tighten set screw when finished.



Caution
Adjusting the handle tension changes the amount of pressure the headrest will support.

The headrest must safely support the patients head when the table is in use. Always test the headrest following any handle tension adjustment.

MA698600i

Rotational Base Brake System

Magnet Position Adjustment

If the rotational brake will not unlock, the electro-magnet may be out of adjustment.

Magnet Position Adjustment

Step 1: Rotate the base to access the brake lever cover. Remove brake lever cover.

Note: If the brake will not release, the base can still be rotated manually by applying additional force.

The brake lever cover is located between the upper & lower base castings at the patient's left rear corner.

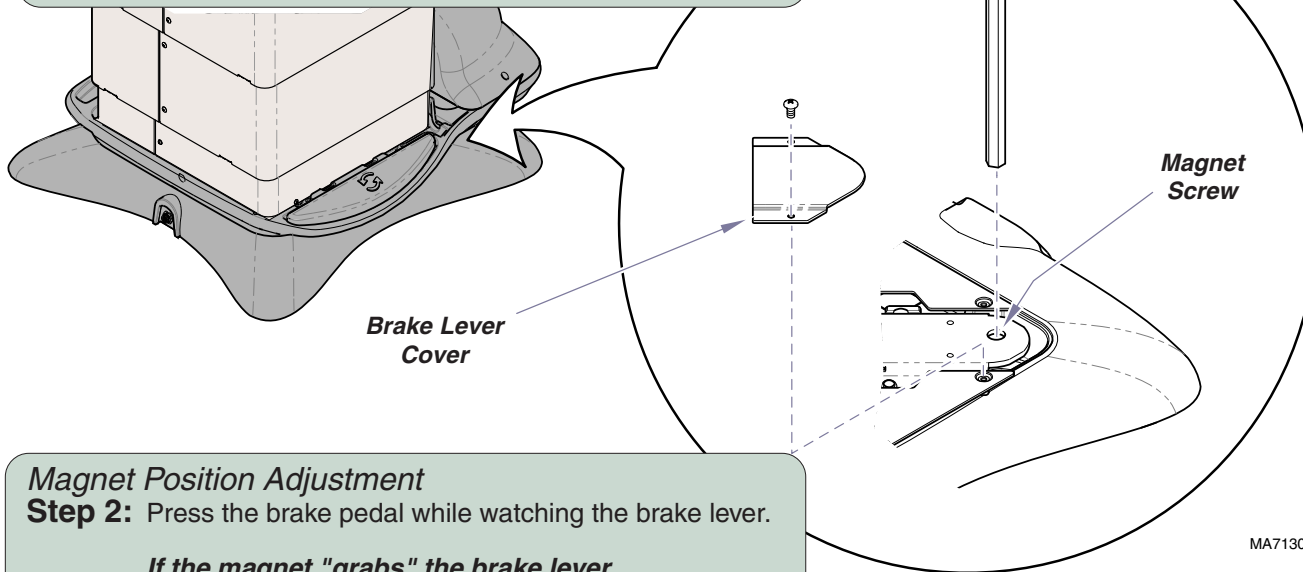

Magnet Position Adjustment

Step 2: Press the brake pedal while watching the brake lever.

If the magnet "grabs" the brake lever...
Tighten the magnet screw 1/4 turn.

If the magnet does not "grab" the brake lever...
Loosen the magnet screw 1/4 turn.

Check for proper operation. Repeat if necessary.

Rotational Base Brake System Page

Magnet Position Adjustment	B-51
Rotational Brake Electrical Test /	
Fuse Location	B-52
Electro-magnet Test	B-53
EMI Filter Board Test	B-54
Rot. Base PC Board Replacement	B-55
Brake Pedal Switch Replacement	B-56
Separating Upper & Lower	
Base Castings	B-57
Brake Lever & Electro-magnet	
Replacement	B-62
Foot Control Inlet / Power Inlet /	
EMI Filter Board Replacement	B-63
Wiring Diagrams	D-1
Exploded View / Part Numbers:	
Lower Section	E-29
Upper Section	E-30

Models:
Serial Numbers:

230 (-003)
All

630 (-005 & -006)
All

**Rotational Base
Brake System**

Component Testing & Repair

Rotational Base Brake System - continued

Rotational Brake Electrical Test / Fuse Location

Rotational Brake Electrical Test.

Step 1: Remove PC board cover.

Refer to: Section C - PC Board Cover

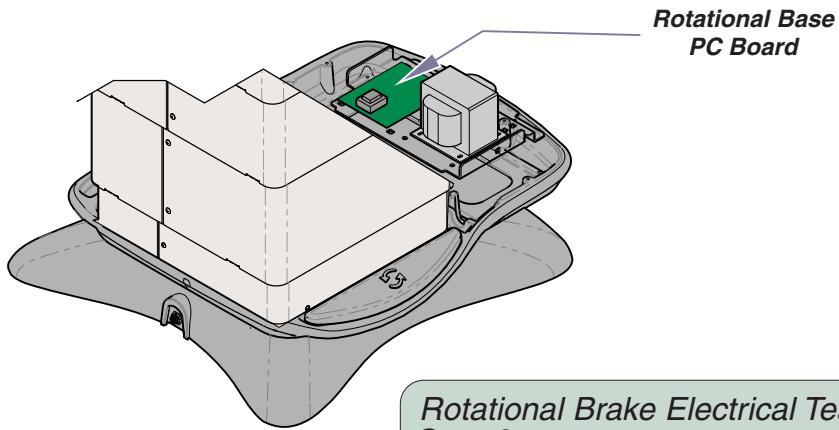

Rotational Brake Electrical Test

Step 3: Place meter probes on wires at J2 on Rotational Base PC Board.

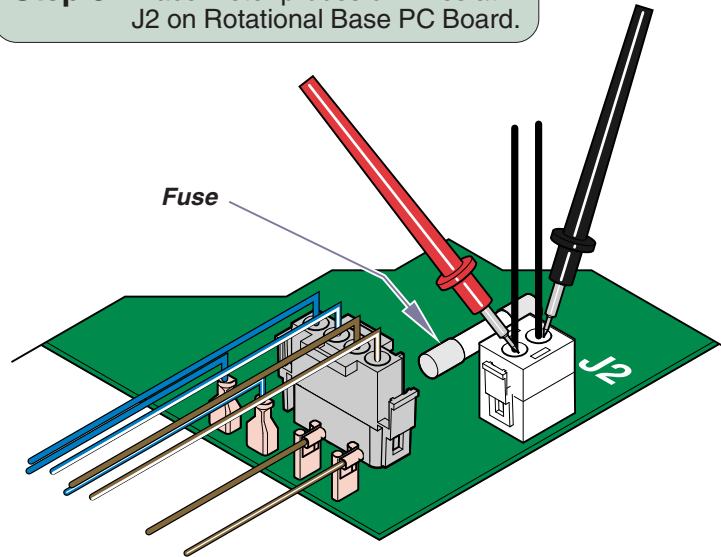

Refer to:

Page

Electro-magnet Test B-53
 Rot. Base PC Board Replacement B-55
 PC Board Cover Removal C-3



Rotational Brake Electrical Test

Step 2: Set meter to VAC.

Rotational Brake Electrical Test

Step 4: Check voltage.

Note: If no voltage is detected, press & release the brake pedal - check voltage again.

Meter Reading	Status	Required Action
15 - 21 VAC		PC board is OK. Perform <i>Electro-magnet Test</i> .
0 VAC		Check Rot. Base PC board fuse. If fuse is OK, replace PC board.

MA713100i

Rotational Base Brake System - continued

Electro-magnet Test

Refer to:

Page

Electro-magnet Replacement B-62

PC Board Cover Removal C-3

Electro-magnet Test.

Step 1: Remove PC board cover.

Refer to: Section C - PC Board Cover

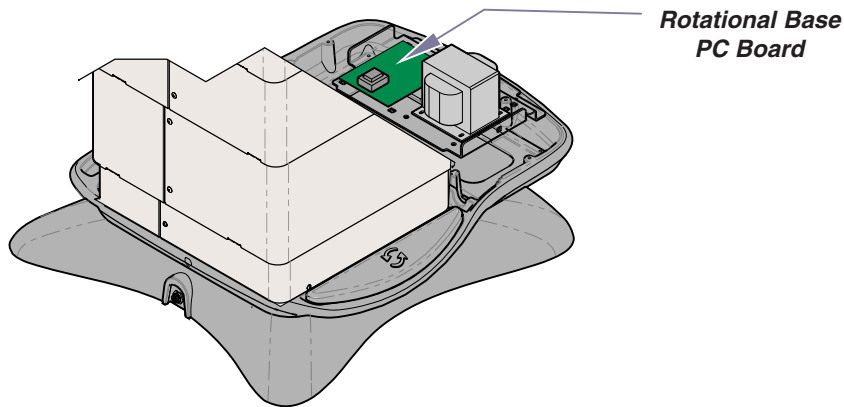

Electro-magnet Test.

Step 2: Set meter to Ω .

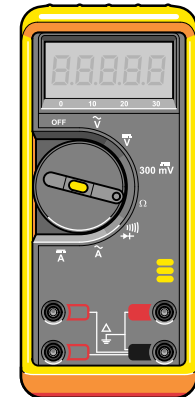

Electro-magnet Test.

Step 4: Place meter probes on wire harness.

Electro-magnet Test.

Step 3: Disconnect electro-magnet wire harness from J2 on Rotational Base PC Board.

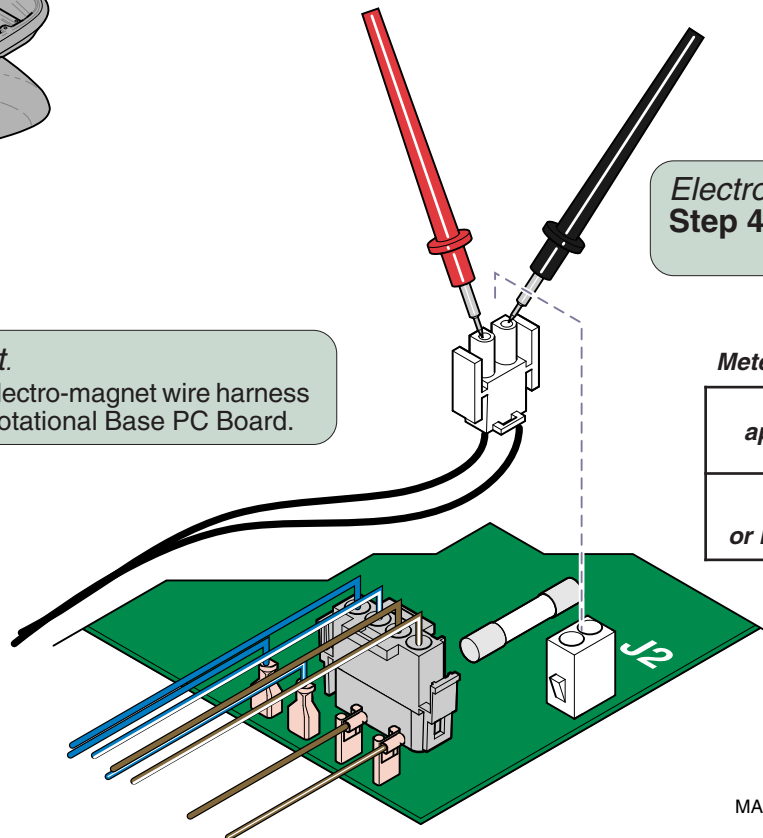

Meter Reading

Status

Required Action

approx. 10 Ω



Electro-magnet is OK.
Check mechanical components.

OL -
or less than 5 Ω



Inspect magnet wire harness.
If OK, replace electro-magnet.

MA713200i

Models:
Serial Numbers:

230 (-003)
All

630 (-005 & -006)
All

**Rotational Base
Brake System**

Component Testing & Repair

Rotational Base Brake System - continued

EMI Filter Board Test

This test allows you to check for line voltage coming thru the EMI filter board without separating the upper & lower base castings.

Refer to:

Page

Primary Fuses	B-2
EMI Filter Board Replacement	B-63
PC Board Cover Removal	C-3

Rotational Brake Electrical Test.

Step 1: Remove PC board cover.

Refer to: Section C - PC Board Cover

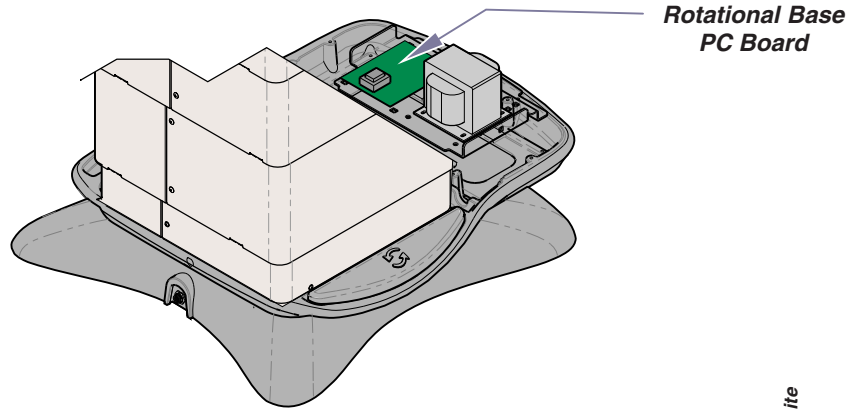

Rotational Brake Electrical Test

Step 2: Set meter to VAC.

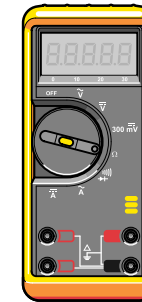

Rotational Brake Electrical Test

Step 3: Place meter probes on blue wire and brown / white wire at J3 on Rotational Base PC Board.

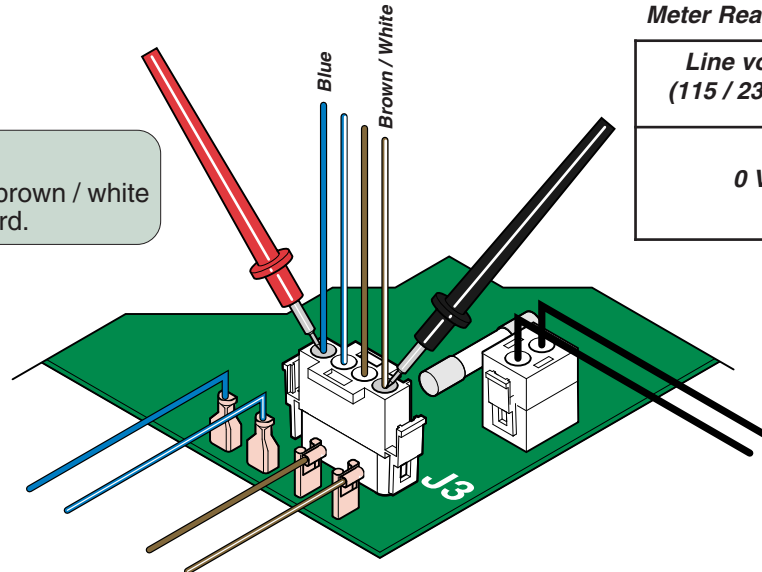

Meter Reading	Status	Required Action
Line voltage (115 / 230 VAC)		EMI Filter board is OK. Check connections to main PC board.
0 VAC		Check primary fuses & wire harness. If fuses & harness are OK, replace EMI filter board.

MA717800i

Rotational Base Brake System - continued

Refer to: [Page](#)
PC Board Cover Removal C-3

Rotational Base PC Board Replacement

Removal.

Step 1: Remove PC board cover.
Refer to: *Section C - PC Board Cover*

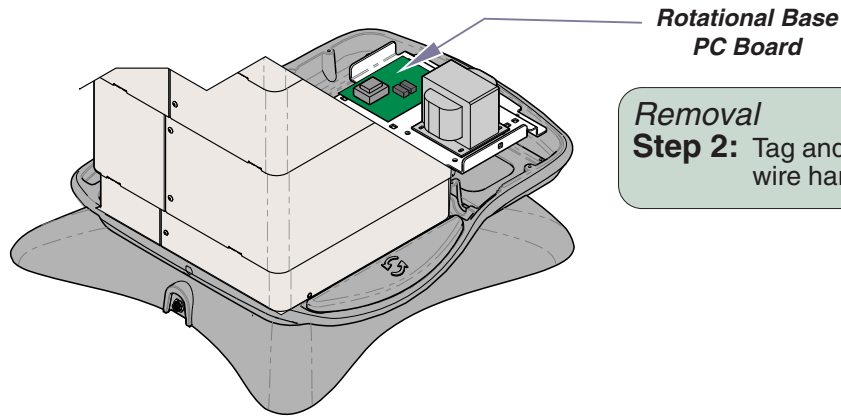

Removal

Step 2: Tag and disconnect all wire harnesses from board.

Installation

Step 2: Connect all wire harnesses to proper terminals.

Removal

Step 3: Push tabs back and remove board from mounting studs.

Installation

Step 1: Align board with mounting studs, then press down until tabs lock board in place.

Note: To minimize stress on the board, work from one end to the other.

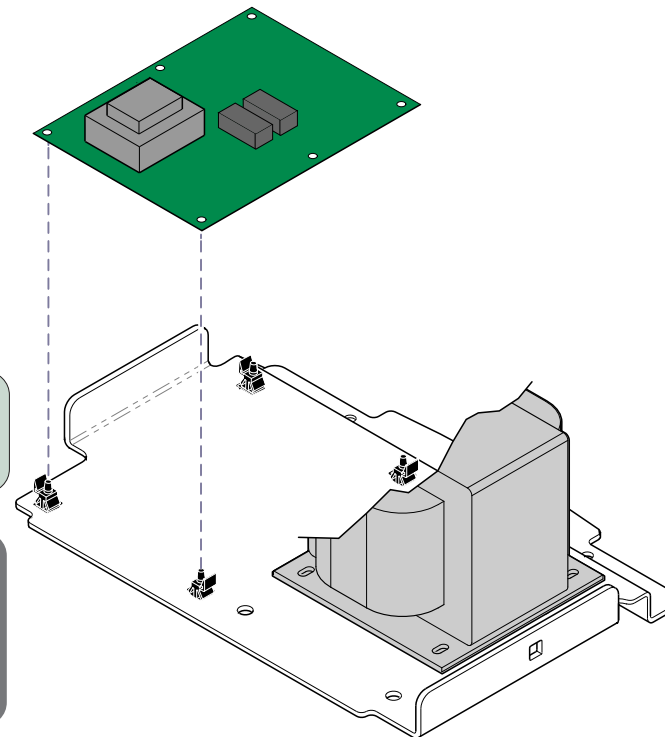

MA714900i

Models:
Serial Numbers:

230 (-003)
All

630 (-005 & -006)
All

**Rotational Base
Brake System**

Component Testing & Repair

Rotational Base Brake System - continued

Brake Pedal Switch Replacement

Refer To:	Page
Base Shrouds:	
Raising (w/bungee cord)	C-4

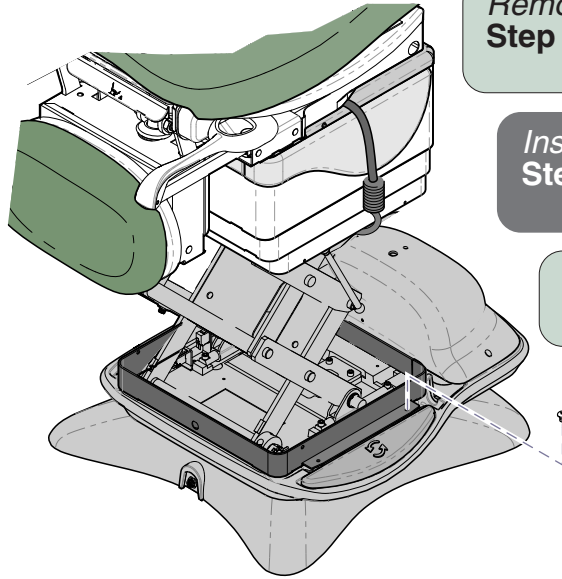

Removal.
Step 1: Raise base shrouds.
Refer to: Section C - Base Shrouds

Installation
Step 3: Secure shroud spacer w/ two screws.
Lower base shrouds.

Removal.
Step 2: Remove two screws from shroud spacer.

Installation
Step 2: Install brake pedal.
Connect wires to proper terminals.

Removal.
Step 3: Remove brake pedal.
Note: Pivot brake pedal toward column, then press down and push forward to release.

Removal.
Step 4: Tag & disconnect wires from switch.
Remove switch.

Installation
Step 1: Install switch.
Connect wires to proper terminals.

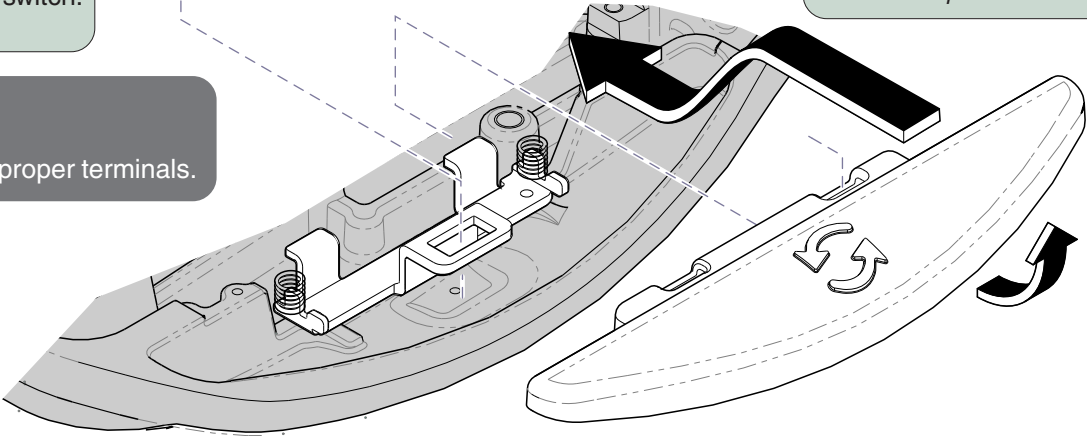
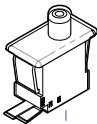

MA715000i

Models:	230 (-003)	630 (-005 & -006)
Serial Numbers:	All	All

Component Testing & Repair

Rotational Base Brake System - continued

Separating Upper & Lower Base Castings

Separating

Step 1: Route bungee cord across top of base column (*under seat*).

Note: It may be necessary to run the Tilt UP function to route bungee cord under seat section.

Separating

Step 2: Run Base UP function to its max height. Position table so that foot & back sections are level as shown.

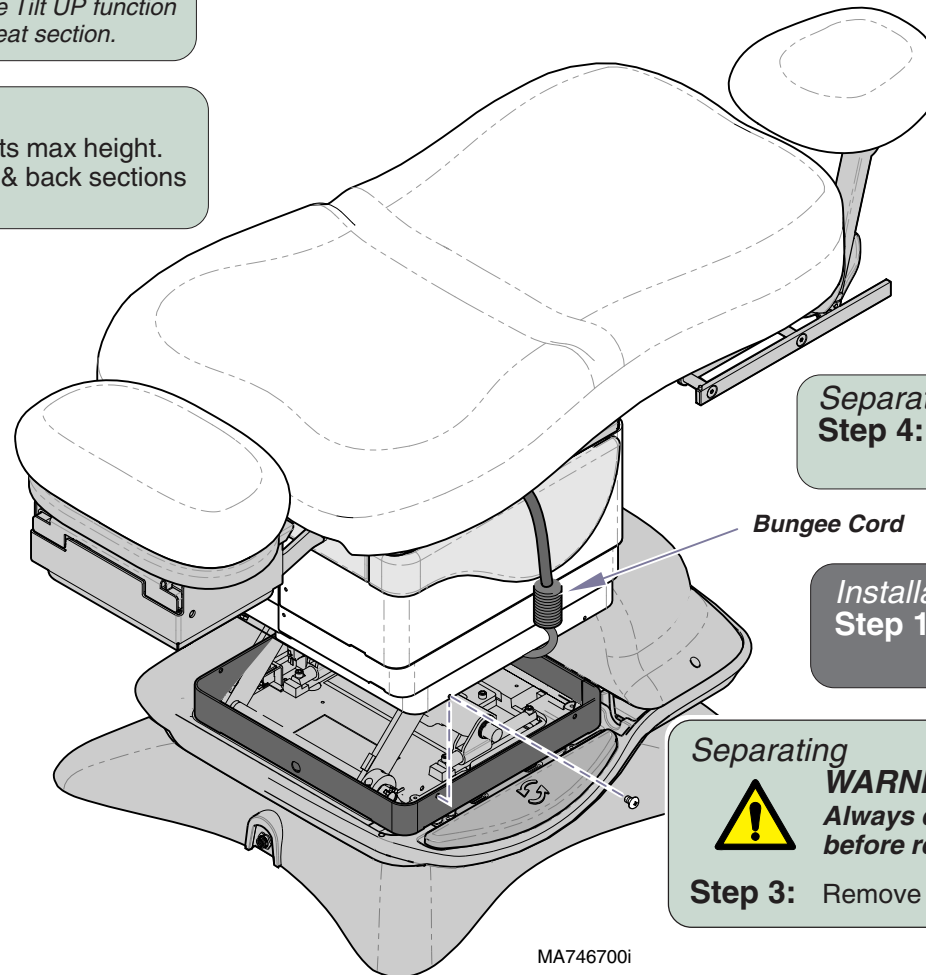

Separating

Step 4: Raise shrouds, then attach bungee cord hooks under shrouds on both sides.

Installation

Step 10: Remove bungee cord. Secure inner shrouds w/screws.

Separating

WARNING

Always disconnect table power cord before removing any covers or shrouds.

Step 3: Remove bottom screws from inner shrouds.

MA746700i

Procedure continued on following page...

Models:
Serial Numbers:

230 (-003)
All

630 (-005 & -006)
All

**Rotational Base
Brake System**

B-57

Component Testing & Repair

Rotational Base Brake System - continued

Separating Upper & Lower Base Castings - continued

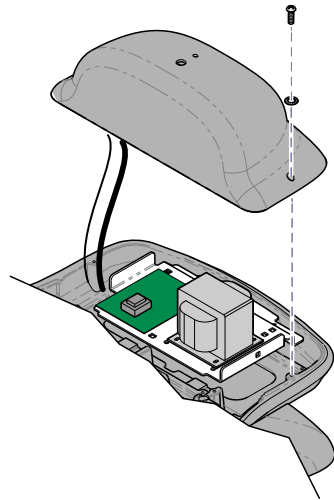

Removal
Step 5: Partially separate PC board cover.

Note: Do not disconnect wire harnesses.

Installation
Step 9: Replace PC board cover.

Installation
Step 7: Install wire harness cover.

Removal
Step 7: Remove wire harness cover.

Removal
Step 6: Remove shroud spacer.

Installation
Step 8: Install shroud spacer.

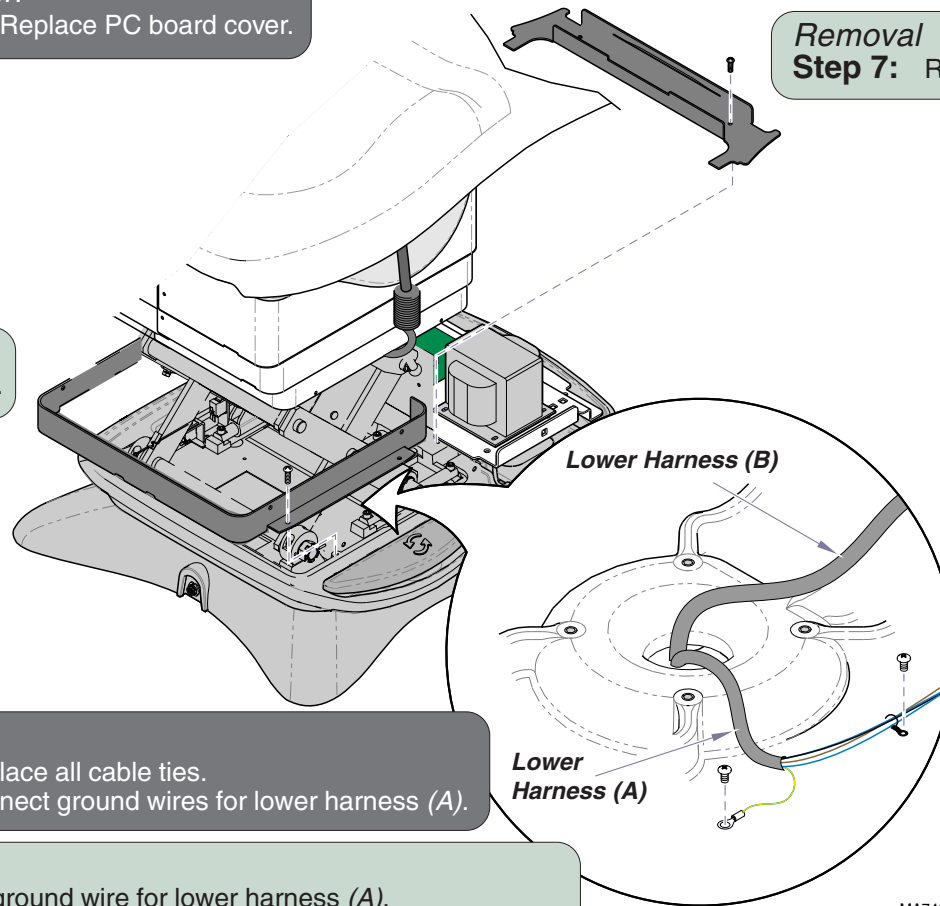

Installation
Step 6: Replace all cable ties.
Connect ground wires for lower harness (A).

Removal
Step 8: Disconnect ground wire for lower harness (A).
Remove cable ties securing lower harnesses (A & B) to base.

MA7466001

Procedure continued on following page...

Component Testing & Repair

Rotational Base Brake System - continued

Separating Upper & Lower Base Castings - continued

Removal



CAUTION

The table weighs approx. 540 lbs (244 kg).
Use supports designed for this amount of weight.

Step 9: Position sawhorses (or other suitable supports) under back section weldment & foot section weldment.

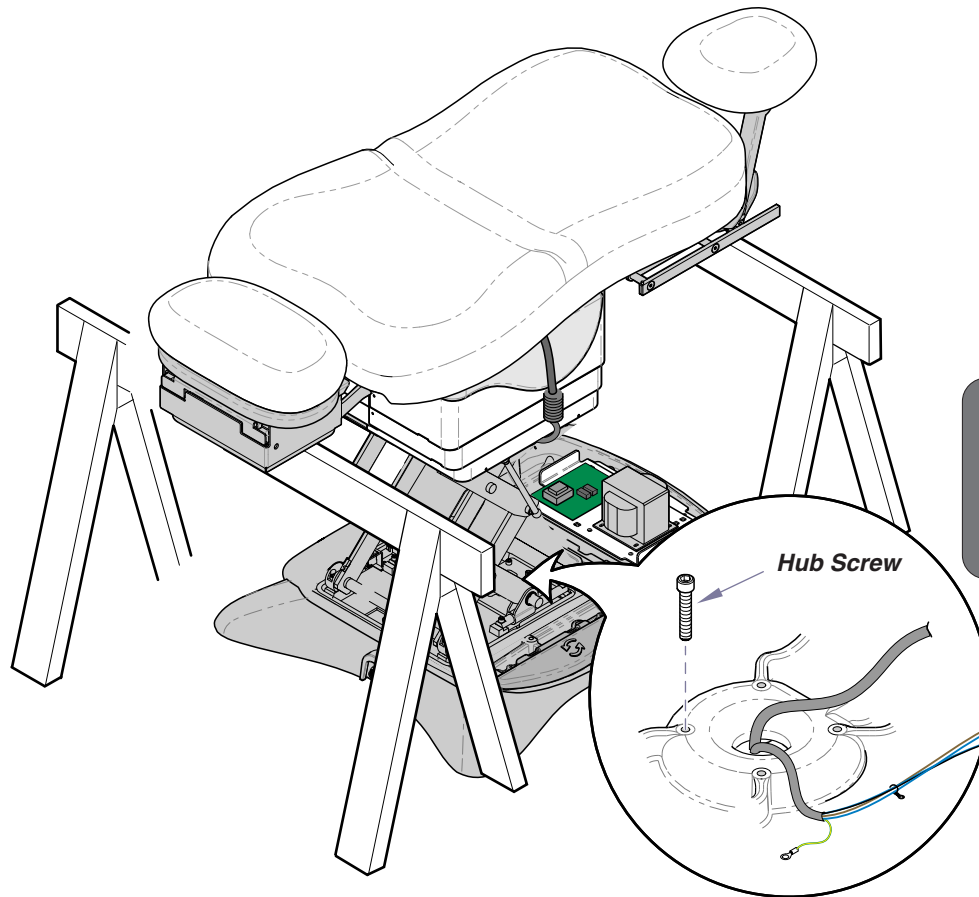

Installation



WARNING

Disconnect the table power cord before performing the remaining Installation steps.

Step 5: Install four hub screws.

Removal



CAUTION

The table top / upper base is not secured once the hub screws are removed. Hold onto the table when performing the following steps.

Step 10: Remove four hub screws.

MA715200i

Procedure continued on following page...

Models:
Serial Numbers:

230 (-003)
All

630 (-005 & -006)
All

**Rotational Base
Brake System**

B-59

Component Testing & Repair

Rotational Base Brake System - continued

Separating Upper & Lower Base Castings - continued

Removal & Installation



WARNING

The Removal & Installation steps on this page require power to be connected to the table. Avoid all contact with wiring & electrical components.

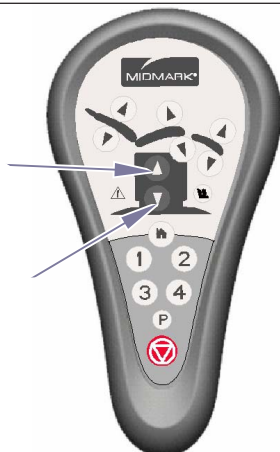

Base UP

Base DOWN

Removal



Equipment Alert

The two lower wire harnesses are still connected to upper casting. Running the Base Down function too long may result in damage to the table.

Step 11: Press **Base DOWN** button on hand or foot control until upper and lower base castings separate slightly.

Installation



CAUTION

The table top / upper base is not secured until the hub screws are installed. Hold onto the table when performing the following steps.

Step 3: Press **Base UP** button on hand / foot control until table raises (slightly) off of sawhorses.

Installation

Step 4: Carefully adjust table top until alignment studs on bottom of upper casting lock into the notches on the rotation wheel.

Note: You will feel table top drop into place when alignment studs engage notches.

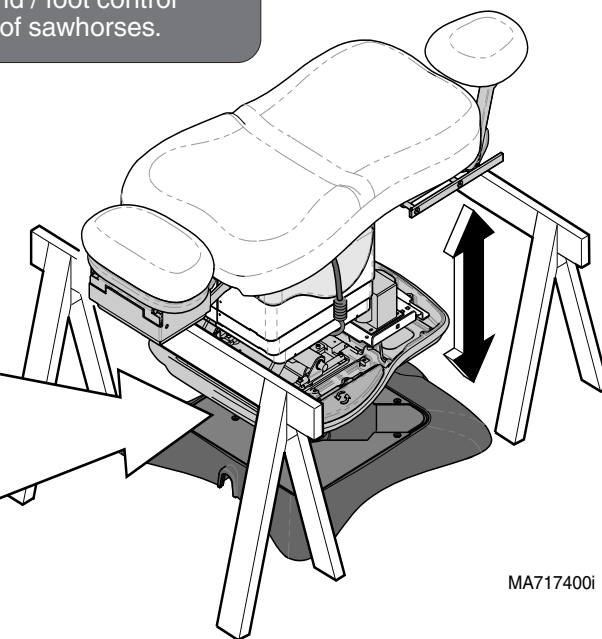
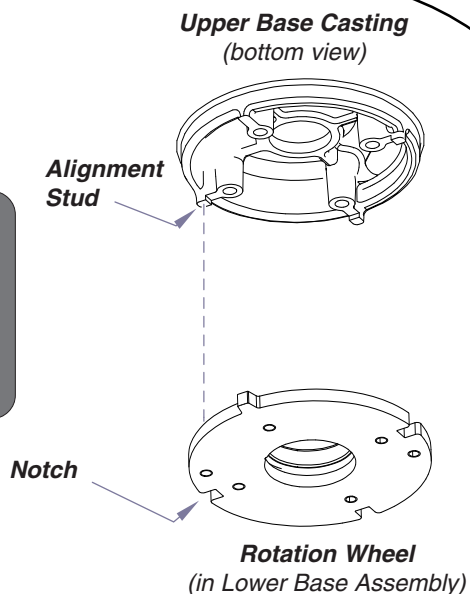

MA717400i

Procedure continued on following page...

Component Testing & Repair

Rotational Base Brake System - continued

Separating Upper & Lower Base Castings - continued

Installation

Step 2: Route wire harnesses thru upper casting. Reconnect all wire harnesses as shown.

Removal & Installation



WARNING

Disconnect table power cord before performing any of the Removal / Installation steps on this page.

Removal

Step 12: Disconnect wire harness from J2 & J3 on rotational base PC board.

Removal

Step 13: Disconnect wire harness from J9 on main PC board.

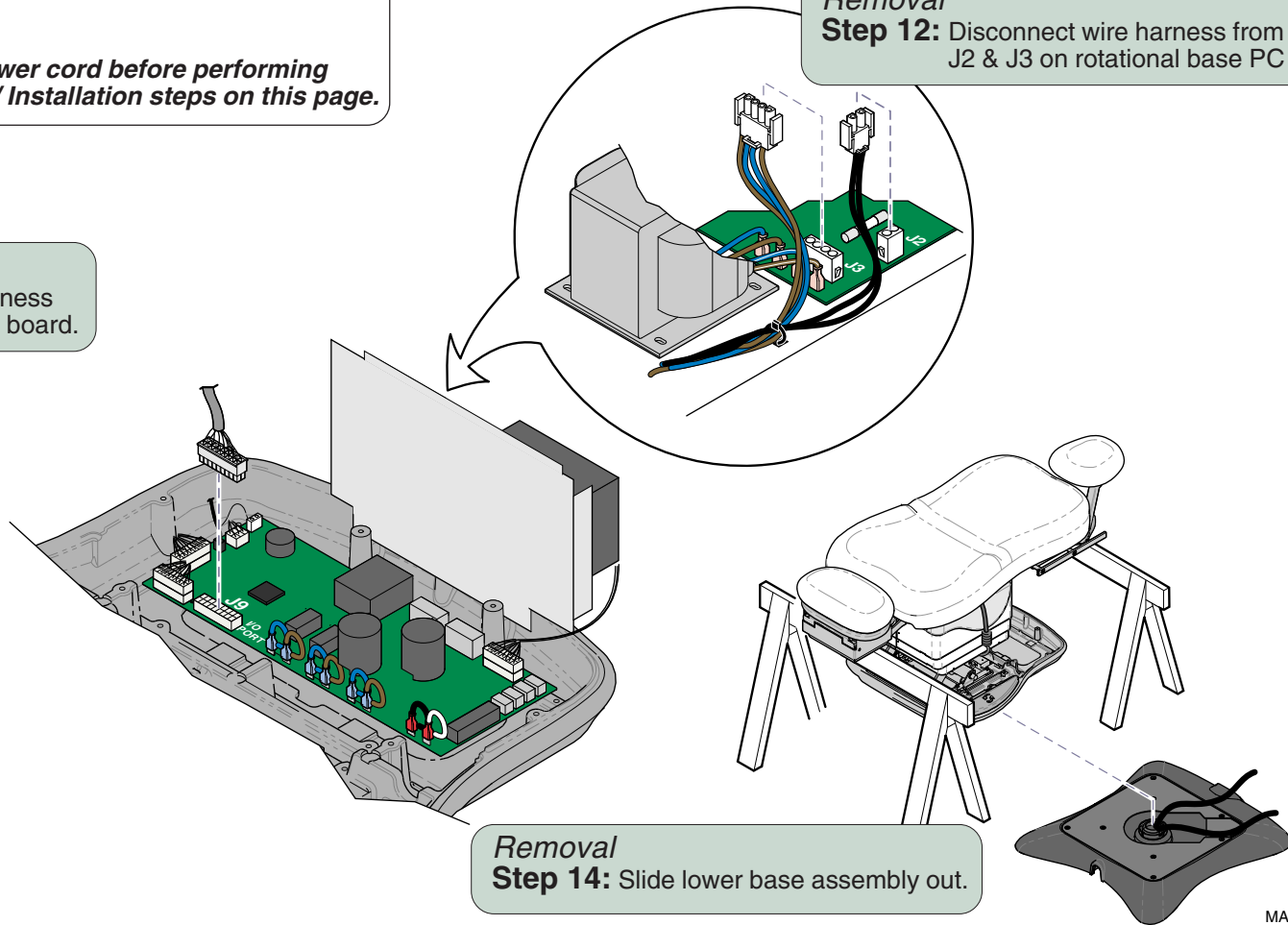

Removal

Step 14: Slide lower base assembly out.

Installation

Step 1: Slide lower base assembly under table.

Note: To ease installation, align the new lower base assembly in the same position as the old base.

MA717500i

Models:
Serial Numbers:

230 (-003)
All

630 (-005 & -006)
All

**Rotational Base
Brake System**

B-61

Component Testing & Repair

Rotational Base Brake System - continued

Brake Lever & Power Electro-magnet Replacement

Refer To:	Page
Separating Upper & Lower Base Castings	B-57

Brake Lever Removal

Step 1: Separate upper & lower base castings.
Refer to: Section B - Rot. Base Brake System.

Brake Lever Removal

Step 2: Remove corner cover & top cover from lower base assembly.

Brake Lever Installation

Step 1: Position brake lever so that it aligns w/ slots in brake pad.
Secure lever with two screws.

Note: Be sure roll pins (in brake lever) align with springs

Brake Lever Removal

Step 3: Remove brake lever.

Attention: Check brake pad for excessive wear.
Brake disk should rotate when lever is removed.
Remove any debris in mechanism.

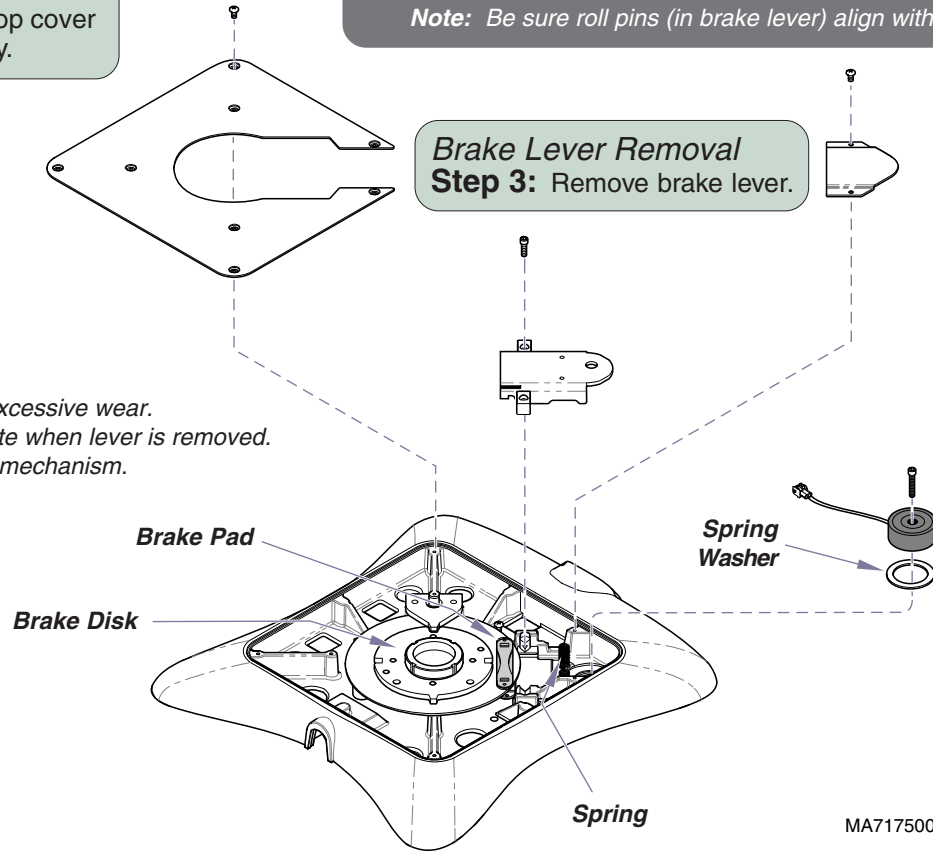

Electro-magnet Removal

Step 1: Remove brake lever.

Electro-magnet Removal

Step 2: Disconnect magnet wire harness.
Remove magnet.

Electro-magnet Installation

Step 1: Connect magnet wire harness.
Install magnet.

Note: Be sure spring washer is in place under magnet.

Rotational Base Brake System - continued

Foot Control Inlet / Power Inlet / EMI Filter Board Replacement

Refer To:

Page

Separating Upper & Lower

Base Castings B-57

Removal (all)

Step 1: Separate upper & lower base castings.
Refer to: Section B - Rot. Base Brake System.

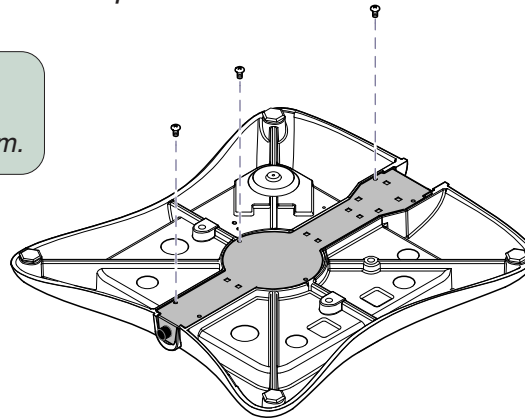

Removal (all)

Step 2: Turn lower base casting upside down.
Remove bottom cover.

To remove EMI filter board...

- A. Tag & disconnect all wires to board.
- B. Remove board from mtg. studs.

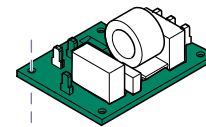

To remove foot control inlet...

- A. Unscrew lock nut.
- B. Remove foot control inlet / harness assembly.

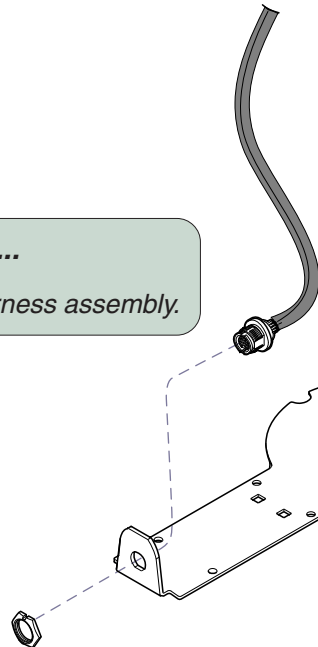

To remove power inlet...

- A. Tag & disconnect all wires to power inlet.
- B. Pry power inlet out of bottom cover.

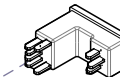

MA717700i

Models:
Serial Numbers:

230 (-003)
All

630 (-005 & -006)
All

**Rotational Base
Brake System**

Section C

Access Procedures

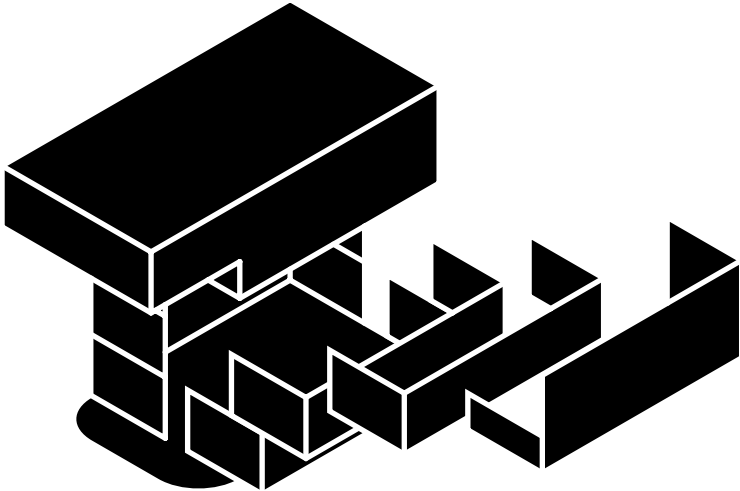
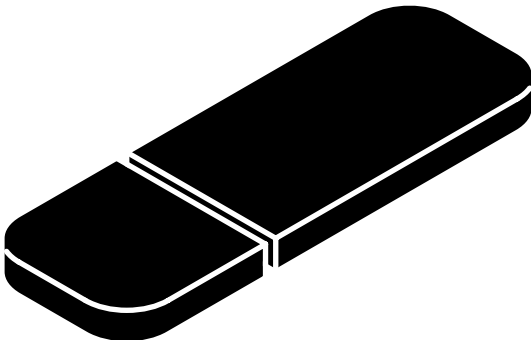

<u>Removing & Installing:</u>	<u>Page</u>
PC Board Cover:	
<i>models w/ Standard Base</i>	C-2
<i>models w/Rotational Base</i>	C-3
Base Shrouds:	
<i>Raising (w/bungee cord)</i>	C-4
<i>Removing / Installing</i>	C-5
Upholstery	C-6
Back Section Covers	C-7
Seat Section Covers	C-8
Foot Section Covers:	
<i>Midmark models</i>	C-9
<i>Ritter models</i>	C-10
Junction Board Cover	C-11

Access Procedures

PC Board Cover (models w/ Standard Base)

Removal / Installation



Caution

Unplug power cord before removing PC Board cover.

Installation

Step 3: Position cover.
Secure with two screws.

Removal

Step 1: Remove two screw(s) and partially separate cover.

Note: You must perform Step 2 before cover can be completely removed.

Installation

Step 2: Connect wire harnesses to J9 & J12 on PC Board.

Removal

Step 2: Disconnect wire harnesses from J9 & J12 on PC Board.

Removal (if necessary)

Step 3: Remove wire harness cover.

Installation (if necessary)

Step 1: Install wire harness cover.

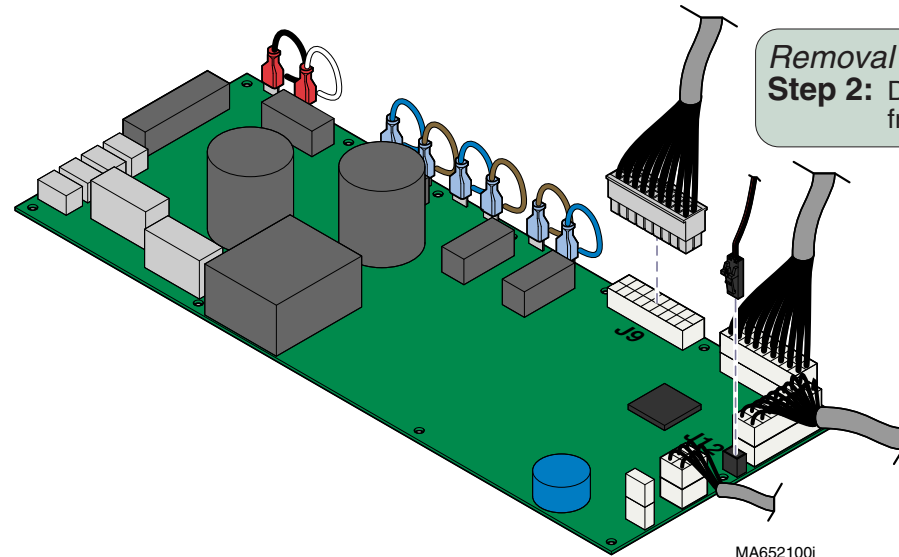
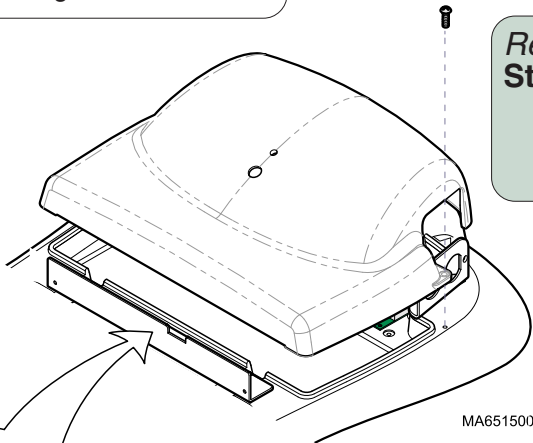

Access Procedures

PC Board Cover (models w/ Rotational Base)

Removal / Installation



Caution
Unplug power cord before removing PC Board cover.

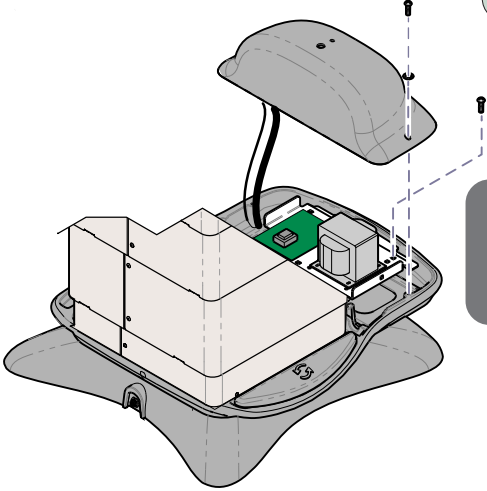

Removal
Step 1: Remove two screw(s) and **partially** separate cover.
Note: You must perform Step 3 before cover can be completely removed.

Removal
Step 2: Remove two screw(s) from transformer mtg. plate.

Installation
Step 3: Secure transformer mtg. plate. Position cover. Secure with two screws.

Removal
Step 4: Disconnect wire harnesses from J9 & J12 on PC Board.

Installation
Step 1: Connect wire harnesses to J9 & J12 on PC Board.

Installation
Step 2: Position transformer mtg. plate so that tab is engaged.

Removal
Step 3: Pull transformer mtg. plate out to disengage tab. Prop mtg. plate up behind two standoffs as shown.

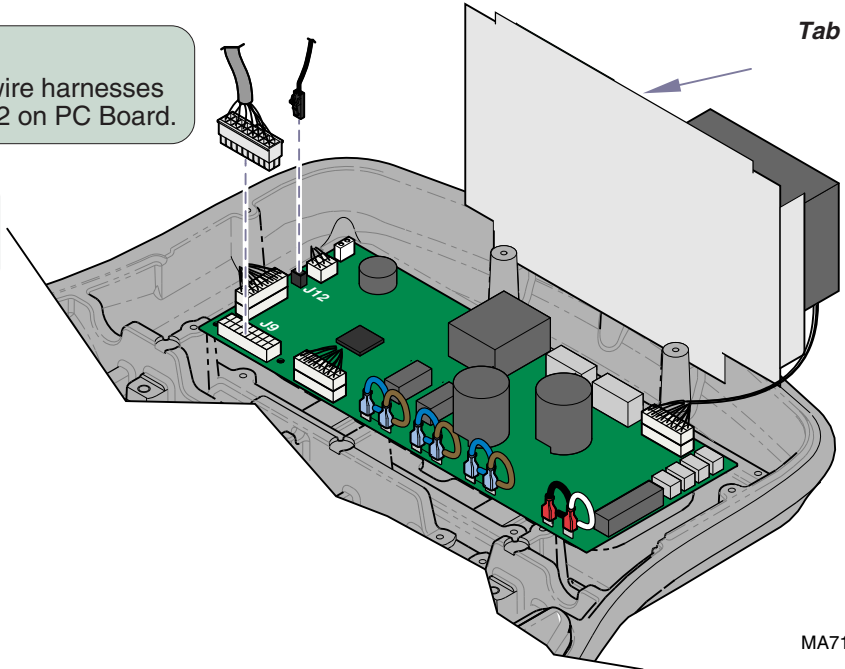

MA713300i

Models:	230 (-003)	630 (-005 & -006)
Serial Numbers:	all	all

PC Board Cover
(Rotational Base)

Access Procedures

Base Shrouds

Raising (w/ bungee cord)

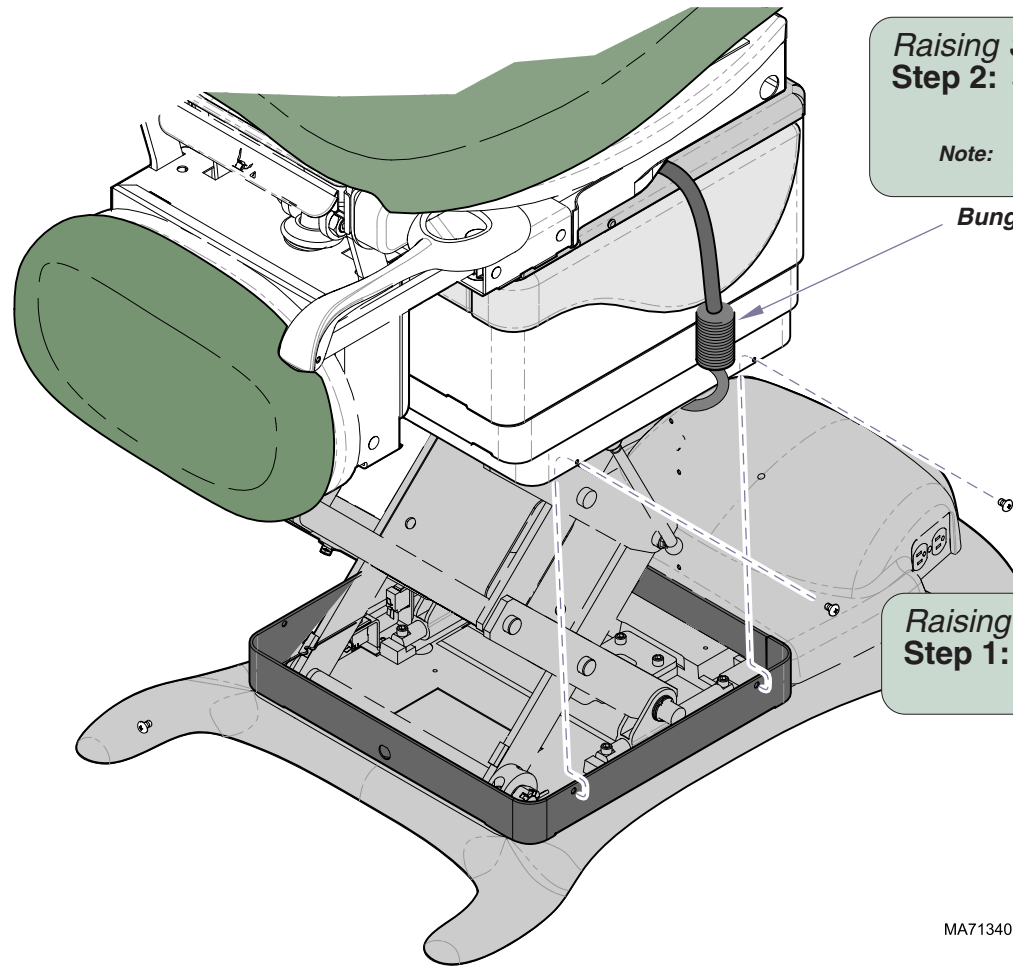

Raising Shrouds

Step 2: Stretch bungee cord across top of base column (*under seat*).

Note: It may be necessary to run Tilt UP function to route bungee cord under seat section.

Bungee Cord

Raising Shrouds

Step 3: Lift shrouds, then attach bungee cord hooks under shrouds on both sides.

Raising Shrouds

Step 1: Remove bottom screws from inner shrouds.

MA713400i

Base Shrouds - continued

Removal / Installation

Installation

Midmark models only

Step 4: Install magnetic covers.



Removal

Midmark models only

Step 1: Remove magnetic covers.

Installation

Step 3: Position outer shrouds.
Secure with screws at both ends.

Note: Insert shroud tabs into seat weldment slots.

Installation

Step 2: Position middle shrouds.
Secure with screws at both ends.

Note: Be sure shroud tabs stack on top of each other.

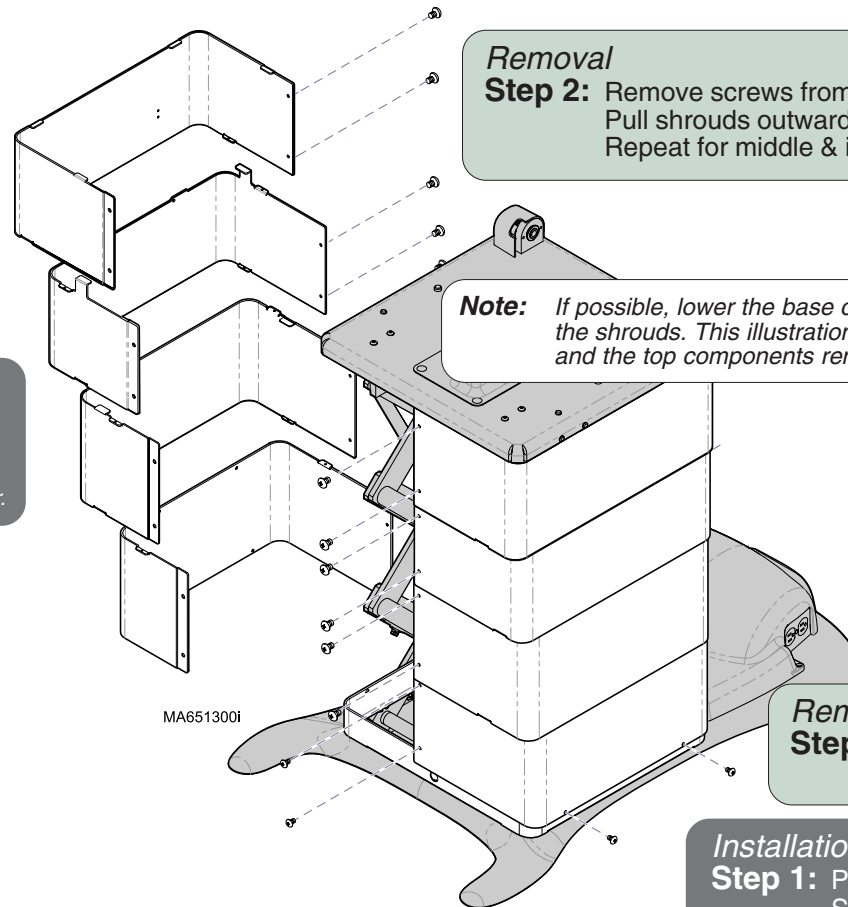

Removal

Step 2: Remove screws from both ends of outer shrouds.
Pull shrouds outward to disengage tabs.
Repeat for middle & inner shrouds

Note: If possible, lower the base completely before removing the shrouds. This illustration shows the base raised, and the top components removed for clarity only.

Removal

Step 3: Remove bottom screws from inner shrouds.

Installation

Step 1: Position inner shrouds.
Secure with screws at both ends and bottom.

Models:
Serial Numbers:

ALL

Base Shrouds

Access Procedures

Upholstery

Removal / Installation

NOTE: Midmark upholstery is shown. The procedure for Ritter upholstery is similar.

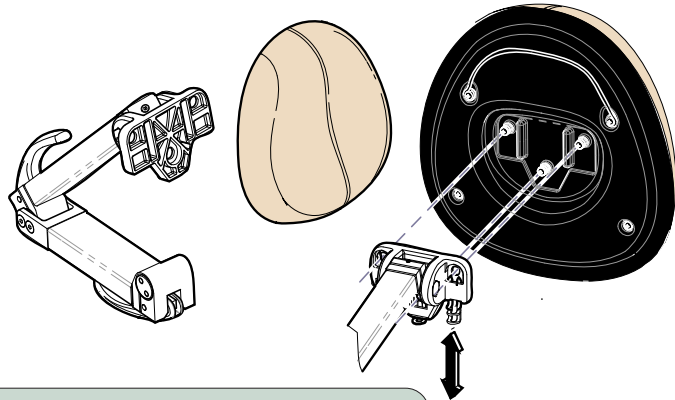

Removal

Step 1: Pull lock levers down to unlock.
Remove headrest pad.

Installation

Step 1: Position headrest pad.
Push lock levers up to secure.

Removal



Equipment Alert

If the table has heated upholstery, you must disconnect heater wires before removing the seat / back section.

Step 2: Pull back / seat section up to release velcro.

Installation

Step 2: Position front of seat section against mounting board.
Lay upholstery flat, then press down firmly.

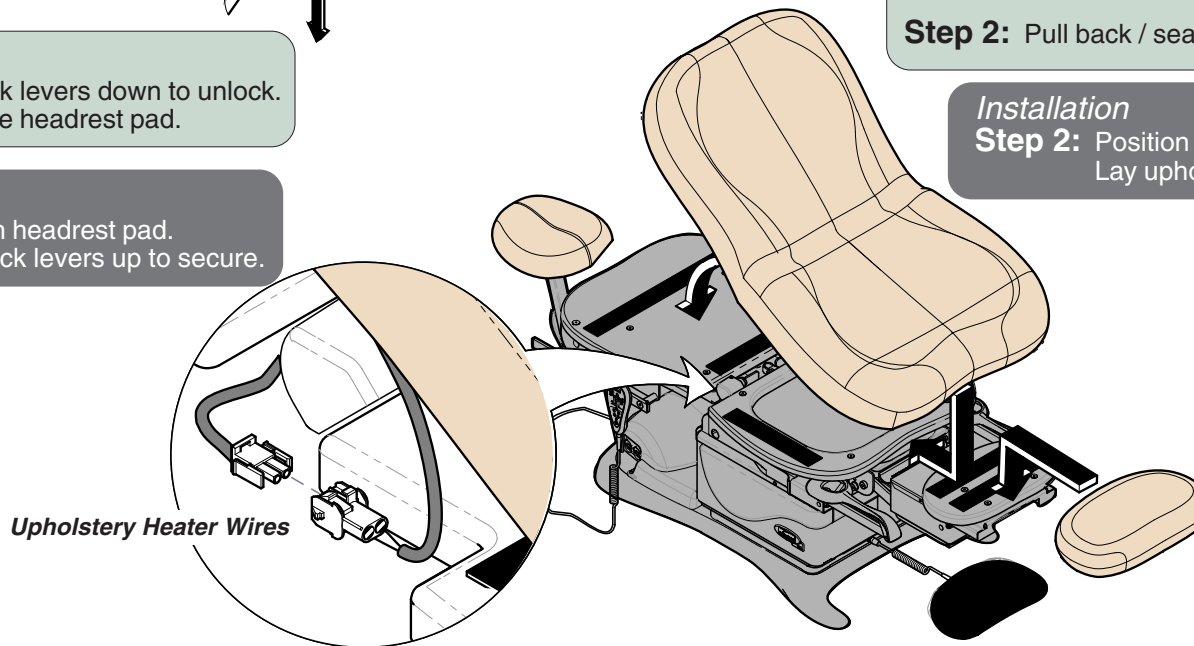

Upholstery Heater Wires

Removal

Step 3: Pull foot section pad up to release velcro.

Installation

Step 3: Align velcro strips.
Press down firmly.

MA651101i

Back Section Covers

Removal / Installation

Refer To: Upholstery Removal / Installation C-6
Page

NOTE: Midmark table is shown. The procedure for Ritter tables is similar.

Removal
Step 1: Remove back / seat upholstery.
(Refer to: Section C - Upholstery Removal)

Removal
Step 2: Remove mounting board and support plate.

Installation
Step 1: Install support plate and mounting board.

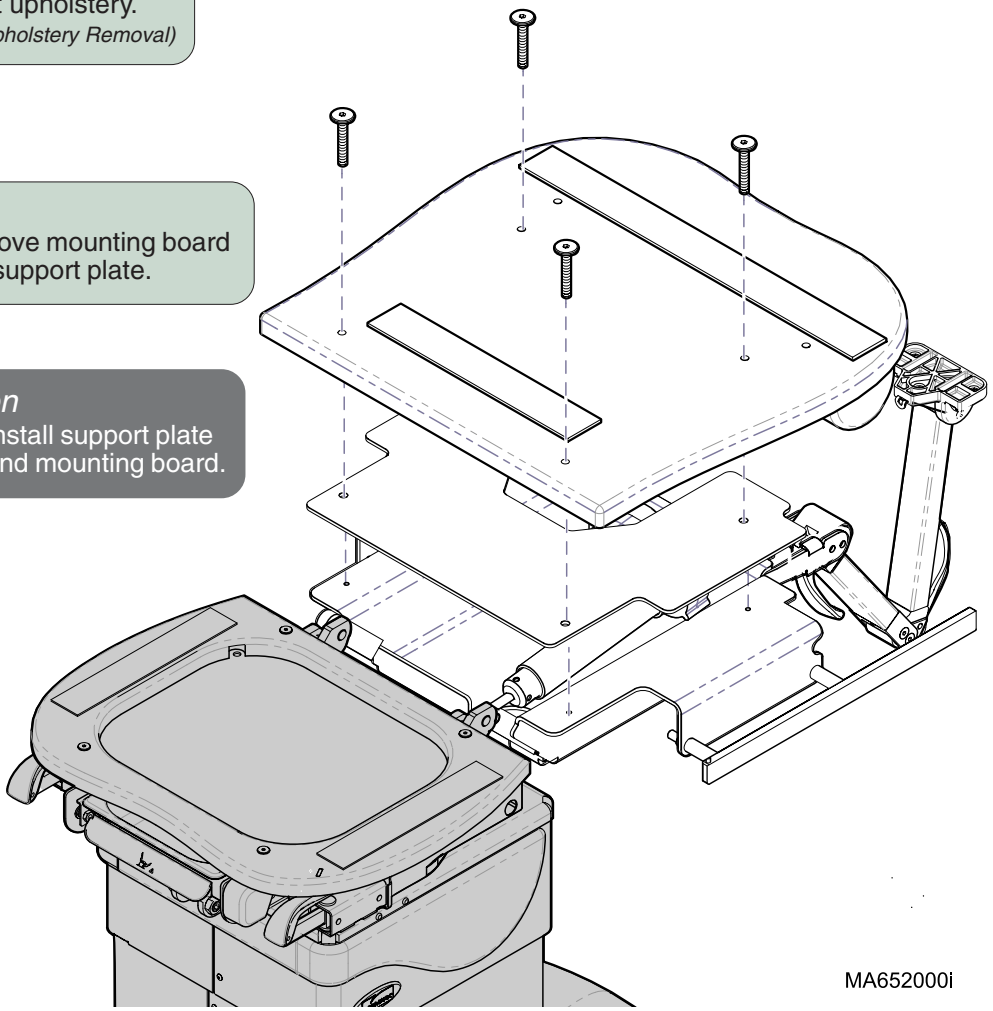

MA652000i

Models: ALL
Serial Numbers:

Back Section Covers

Access Procedures

Seat Section Covers

Removal / Installation

Refer To:

Page

Upholstery Removal / Installation C-6

NOTE: Midmark table is shown. The procedure for Ritter tables is similar.

Removal

Step 1: Remove back / seat upholstery.
(Refer to: Section C - Upholstery Removal)

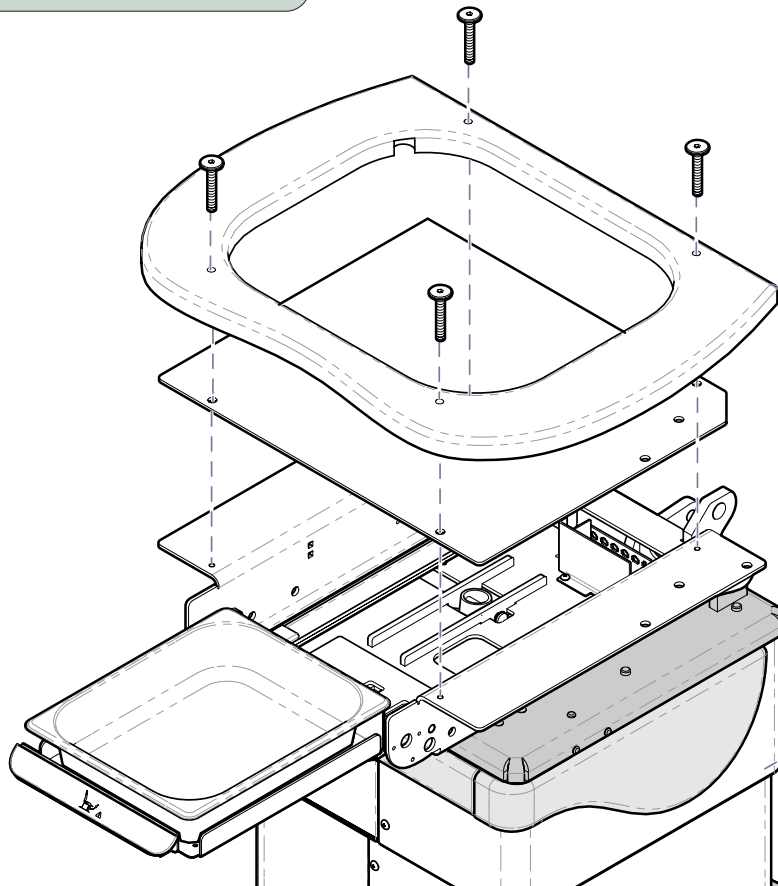

Removal

Step 2: Remove mounting board and support plate.

Installation

Step 1: Install support plate and mounting board.

MA651400i

Foot Section Covers - Midmark Models Removal / Installation

Refer To: Upholstery Removal / Installation C-6
Page

Removal
Step 1: Remove foot upholstery.
(Refer to: Section C - Upholstery Removal)

Removal
Equipment Alert

If the mounting board is installed backwards, it may collide with the floor. Be sure mounting board is oriented as shown.
Step 4: Install mounting board.

Removal
Step 2: Remove mounting board.

Removal
Step 4: Remove two screws and switch trigger bracket.

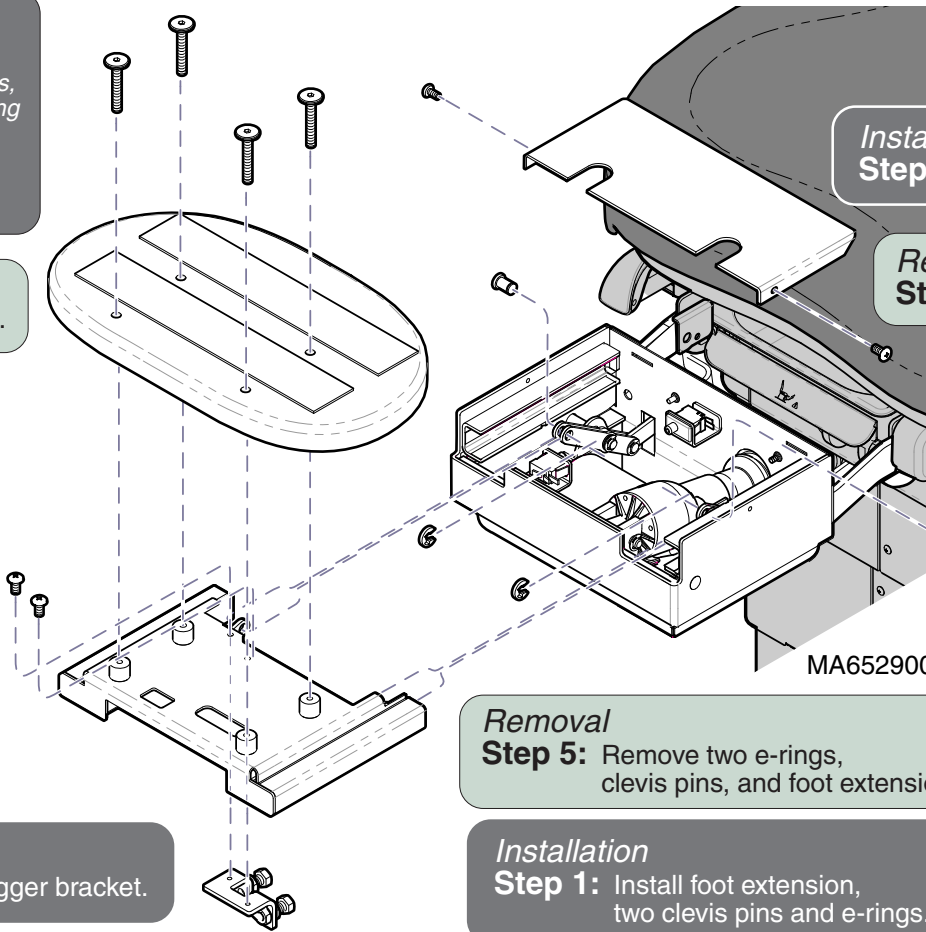
Installation
Step 2: Install switch trigger bracket.



Installation
Step 3: Install foot cover.

Removal
Step 3: Remove foot cover .

Removal
Step 5: Remove two e-rings, clevis pins, and foot extension.

Installation
Step 1: Install foot extension, two clevis pins and e-rings.

Models:	630 (all)	75 (-020/-021)
Serial Numbers:	V1000 thru Present	V1000 thru Present

Foot Section Covers:
Midmark Models

Access Procedures

Foot Section Covers - Ritter Models Removal / Installation

Refer To:

Page

Upholstery Removal / Installation C-6

Removal

Step 1: Remove leg section upholstery.
(Refer to: Section C - Upholstery Removal)

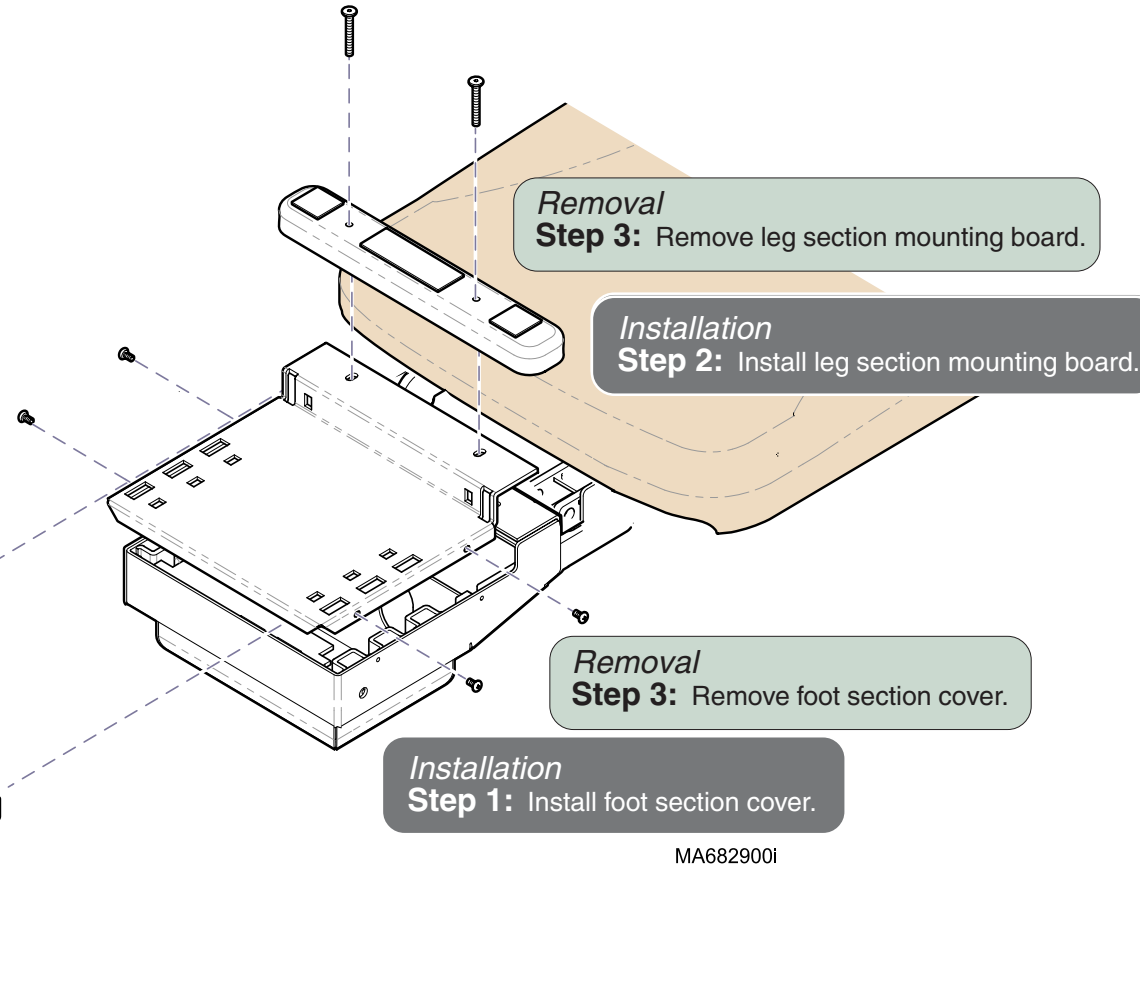

Removal
Step 3: Remove leg section mounting board.

Installation
Step 2: Install leg section mounting board.

Installation
Step 3: Install foot section.

Removal
Step 2: Remove foot section.

Removal
Step 3: Remove foot section cover.

Installation
Step 1: Install foot section cover.

MA682900i

Junction Board Cover Removal / Installation

Refer To:	Page
Seat Section Covers	C-8

Removal
Step 1: Remove seat section covers.
(Refer to: Section C - Seat Section Covers)

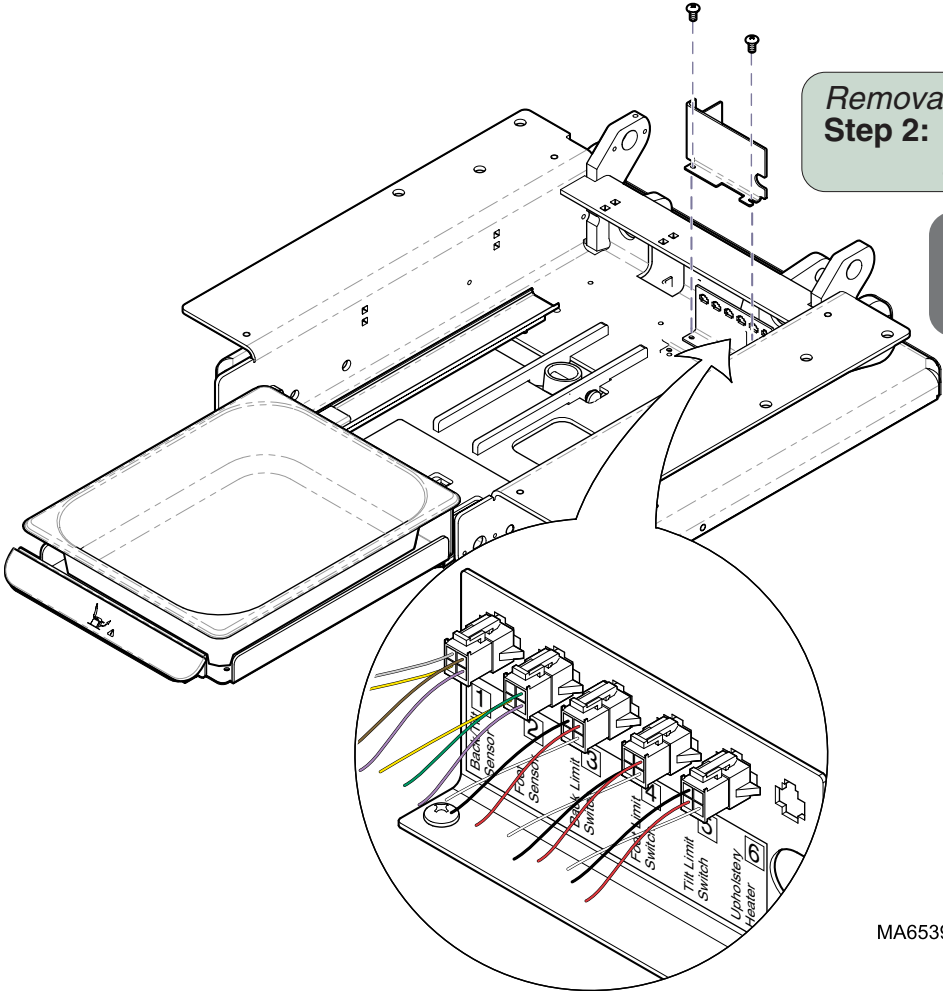

Removal
Step 2: Remove two screws and junction board cover.

Installation
Step 1: Position cover and secure with two screws.

MA653900i

Section D

Wiring Diagrams

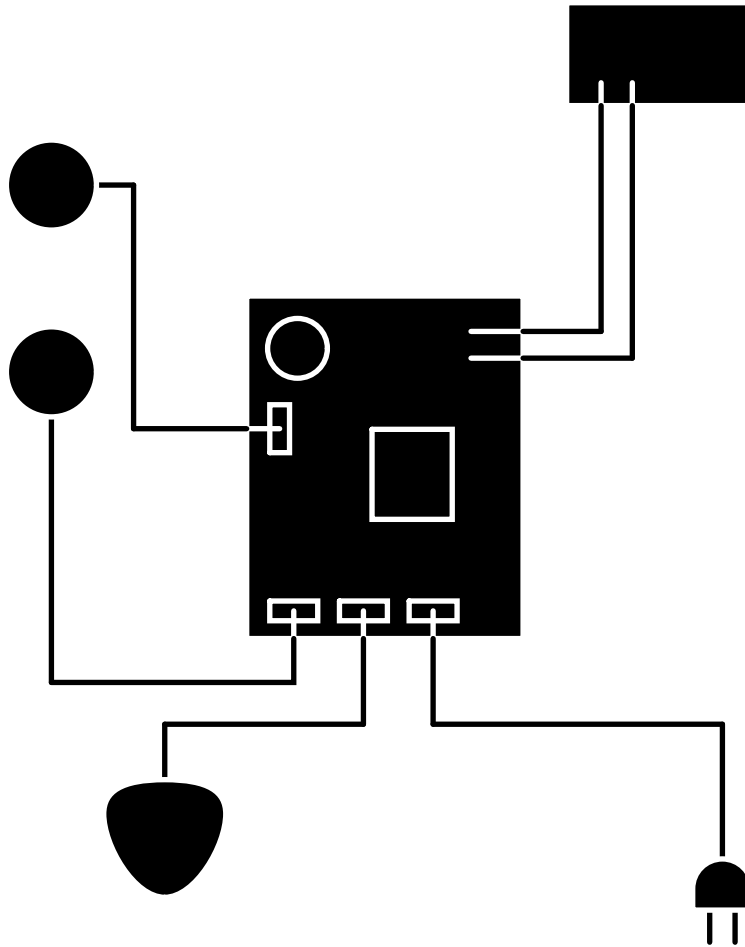

<u>Model</u>	<u>Page</u>
230:	
(-001 & -004)	D-2
(-002)	D-3
(-003)	D-4
630:	
(-001 & -002)	D-5*
(-003 / -004 / -008 / -009)	D-6*
(-005 & -006)	D-7
(-007)	D-8
75:	
(-019)	D-2
(-020 & -021)	D-6*

Wiring Diagrams

Refer To: [Page](#)
Primary Fuses B-2

Item	Harness Description <i>(sensors & switches not included)</i>	Part Number
A*	Connection Port Harness <i>[short - head end]</i> * [Serial Numbers: V370644 thru present]	002-1110-00
B	Connection Port Harness <i>[long - foot end]</i>	002-1110-01
C	Limit Switch Harness - BASE	015-1821-00
D	Power Light Harness <i>[includes green light]</i>	015-1793-00
E	'PC Board to Junction Board' Harness	015-1937-00
F	Tilt Limit Switch Harness	n/a <i>(part of Tilt actuator)</i>
G	Foot Limit Switch Harness	015-1857-00
H	Back Limit Switch Harness	n/a <i>(part of Back actuator)</i>

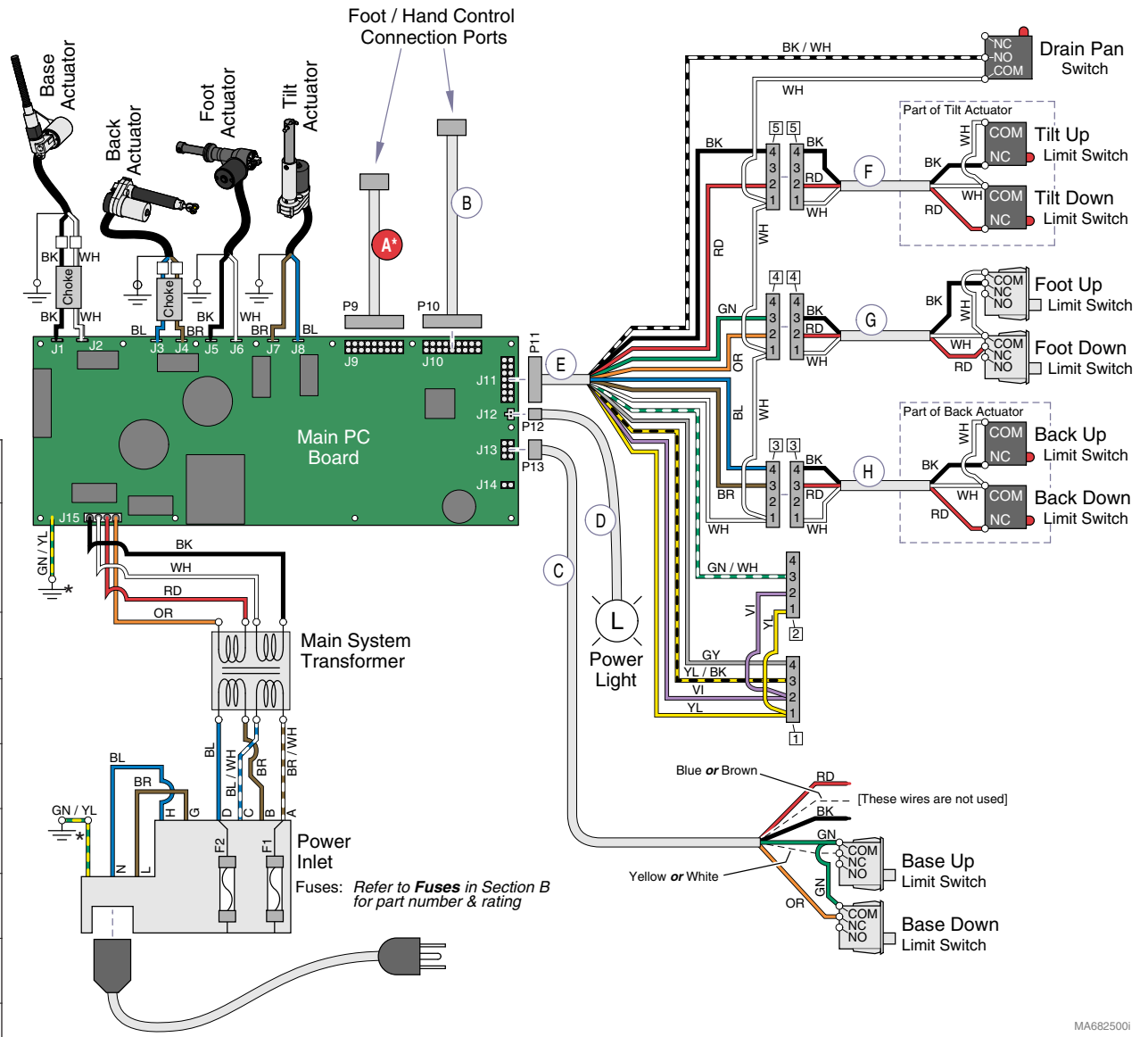

MA6825001

Wiring Diagrams

Refer To: [Page](#)
 Primary Fuses B-2

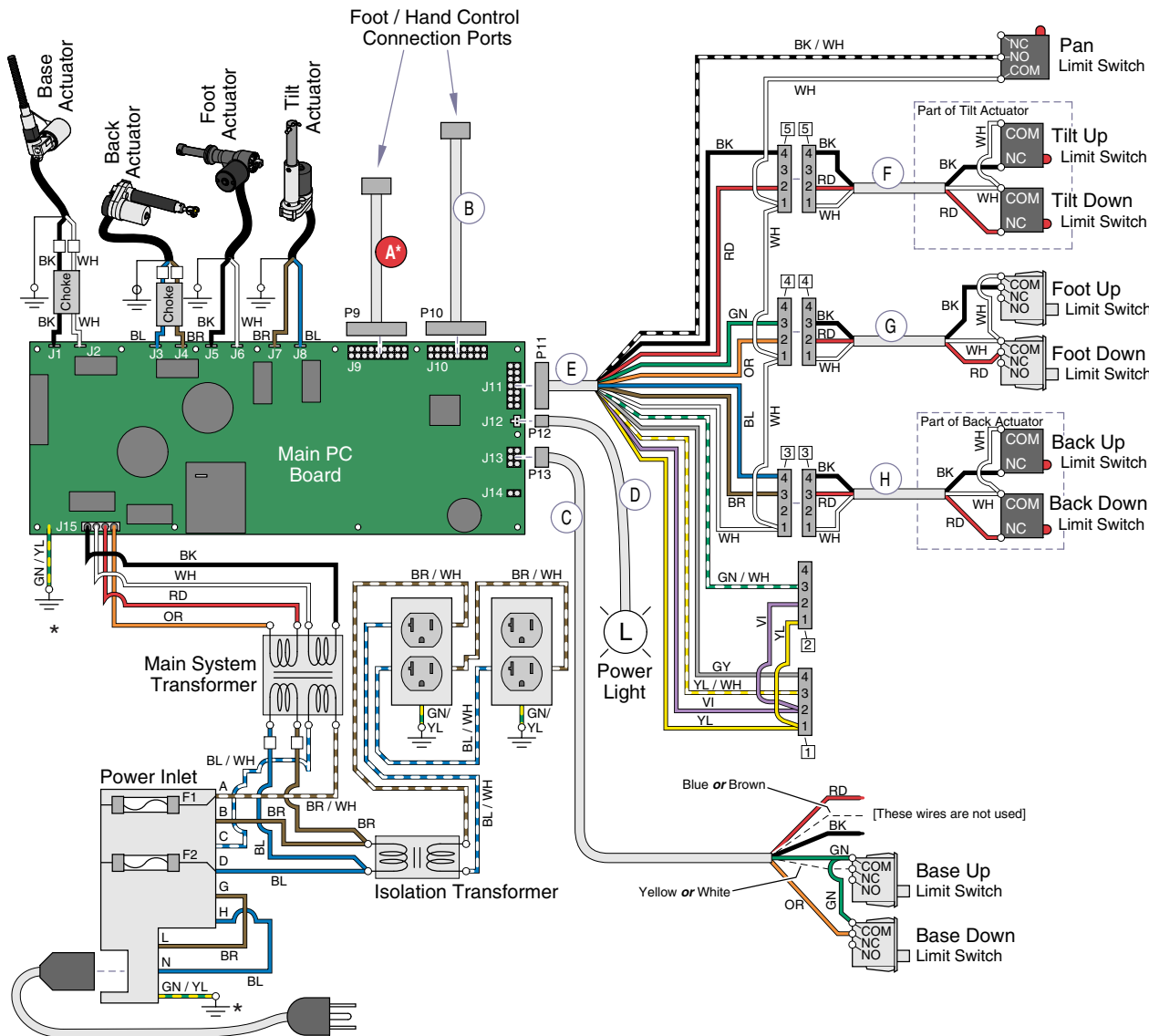

* Ground Wire p/n: 015-1774-03

MA6826001

Item	Harness Description (sensors & switches not included)	Part Number
A*	Connection Port Harness [short - head end] * [Serial Numbers: V370644 thru present]	002-1110-00
B	Connection Port Harness [long - foot end]	002-1110-01
C	Limit Switch Harness - BASE	015-1821-00
D	Power Light Harness [includes green light]	015-1793-00
E	'PC Board to Junction Board' Harness	015-1937-00
F	Tilt Limit Switch Harness	n/a (part of Tilt actuator)
G	Foot Limit Switch Harness	015-1857-00
H	Back Limit Switch Harness	n/a (part of Back actuator)

Models:
Serial Numbers:

230 (-002)
 All

Wiring Diagrams

D-3

Wiring Diagrams

Refer To: Page
 Primary Fuses B-2

Item	Harness Description <i>(sensors & switches not included)</i>	Part Number
A*	Connection Port Harness <i>[short - head end]</i> * [Serial Numbers: V370644 thru present]	002-1110-02
B	Connection Port Harness <i>[long - foot end]</i>	002-1110-03
C	Limit Switch Harness - BASE	015-1821-00
D	Power Light Harness <i>[includes green light]</i>	015-1793-01
E	'PC Board to Junction Board' Harness	015-1937-00
F	Tilt Limit Switch Harness	n/a <i>(part of Tilt actuator)</i>
G	Foot Limit Switch Harness	015-1857-00
H	Back Limit Switch Harness	n/a <i>(part of Back actuator)</i>
I	Brake Switch Harness	015-1967-00
J	Rotational Base PC Board to Power Inlet	015-1966-00
K	Rotational Base PC Board to Main PC Board	015-1968-00

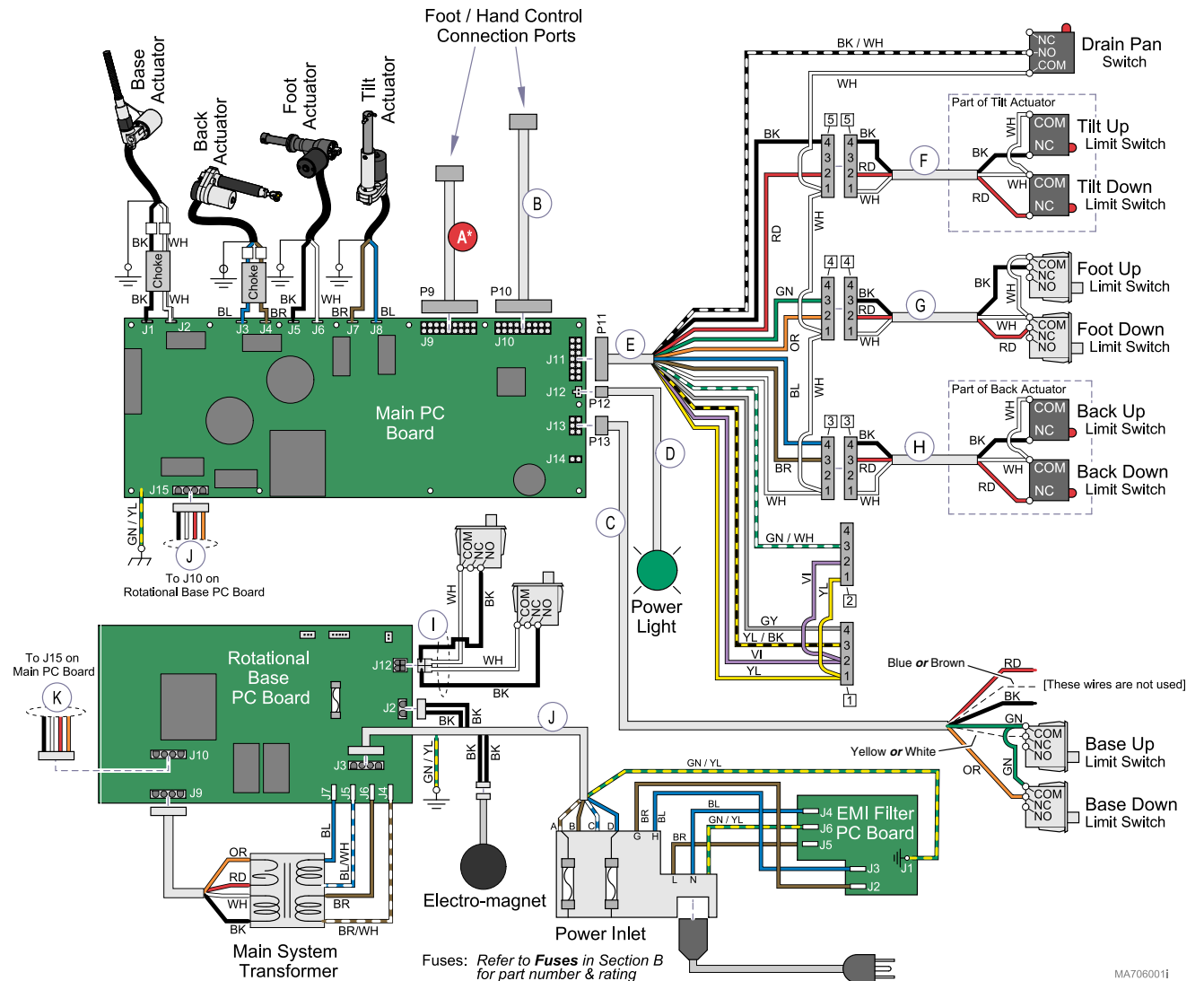

MA706001i

Wiring Diagrams

Refer To: **Page**
 Primary Fuses B-2

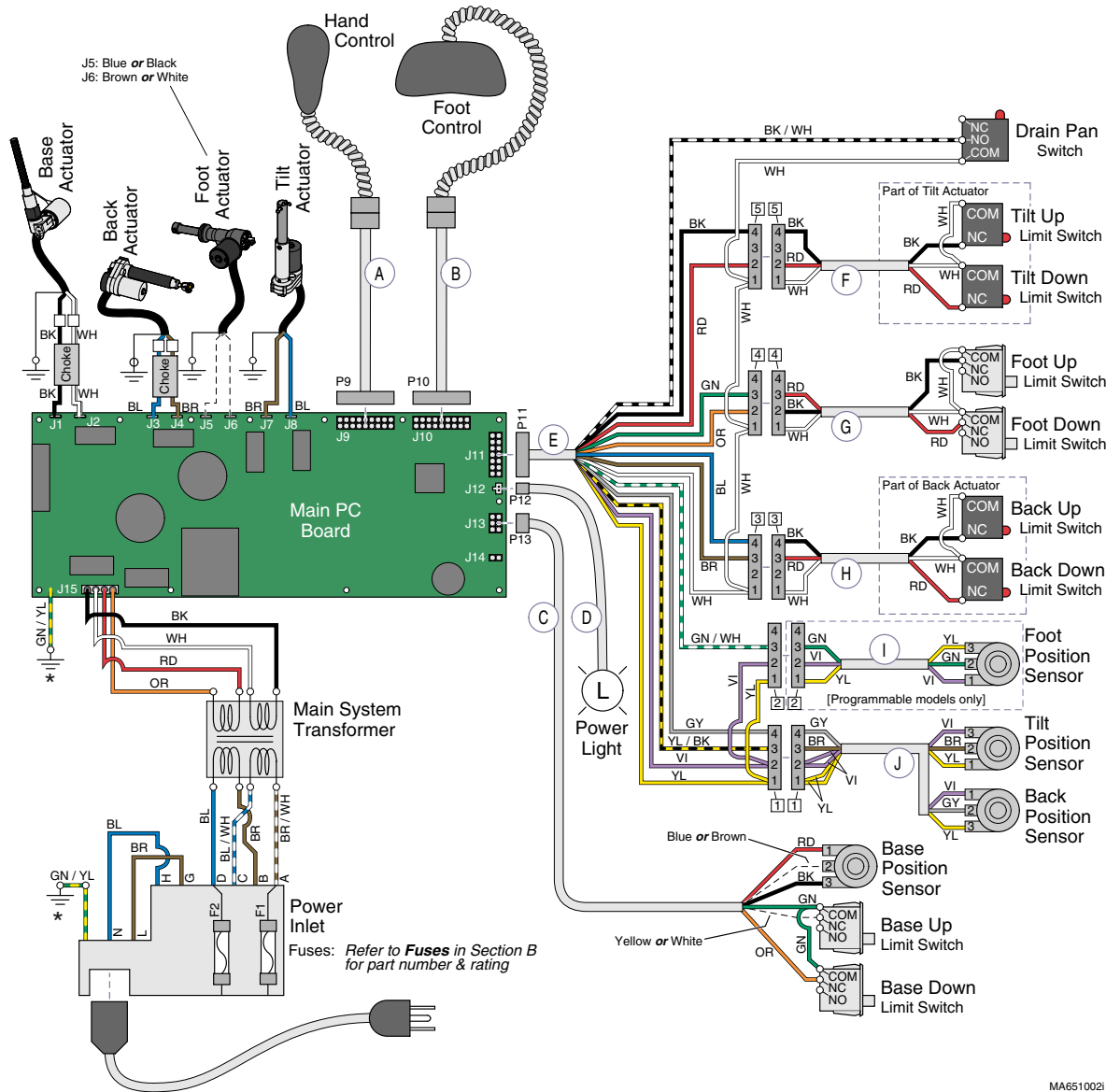

* Ground Wire p/n: 015-1774-03

MA651002

Item	Harness Description <i>(sensors & switches not included)</i>	Part Number
A	Connection Port Harness <i>[short - head end]</i>	002-1110-00
B	Connection Port Harness <i>[long - foot end]</i>	002-1110-01
C	Position Sensor / Limit Switch Harness - BASE	015-1821-00
D	Power Light Harness <i>[includes green light]</i>	015-1793-00
E	'PC Board to Junction Board' Harness	015-1746-00
F	Tilt Limit Switch Harness	n/a <i>(part of Tilt actuator)</i>
G	Foot Limit Switch Harness	015-1731-00
H	Back Limit Switch Harness	n/a <i>(part of Back actuator)</i>
I	Position Sensor Harness - FOOT <i>[Prog. models only]</i>	015-1773-00 <i>(includes sensor)</i>
J	Position Sensor Harness - TILT & BACK	015-1761-00 <i>(incl. both sensors)</i>

Models:
Serial Numbers:

Non-Programmable
630 (-001)
V1000 thru V76347

Programmable
630 (-002)
V1000 thru V77339

Wiring Diagrams

Wiring Diagrams

Refer To:

Primary Fuses B-2

Page

B-2

Item	Harness Description <i>(sensors & switches not included)</i>	Part Number
A	Connection Port Harness <i>[short - head end]</i>	002-1110-00
B	Connection Port Harness <i>[long - foot end]</i>	002-1110-01
C	Position Sensor / Limit Switch Harness - BASE	015-1821-00
D	Power Light Harness <i>[includes green light]</i>	015-1793-00
E	'PC Board to Junction Board' Harness	015-1937-00
F	Tilt Limit Switch Harness	n/a <i>(part of Tilt actuator)</i>
G	Foot Limit Switch Harness	015-1731-00
H	Back Limit Switch Harness	n/a <i>(part of Back actuator)</i>
I	Position Sensor Harness - FOOT <i>[Prog. models only]</i>	015-1773-00 <i>(includes sensor)</i>
J	Position Sensor Harness - TILT & BACK	015-1761-00 <i>(incl. both sensors)</i>

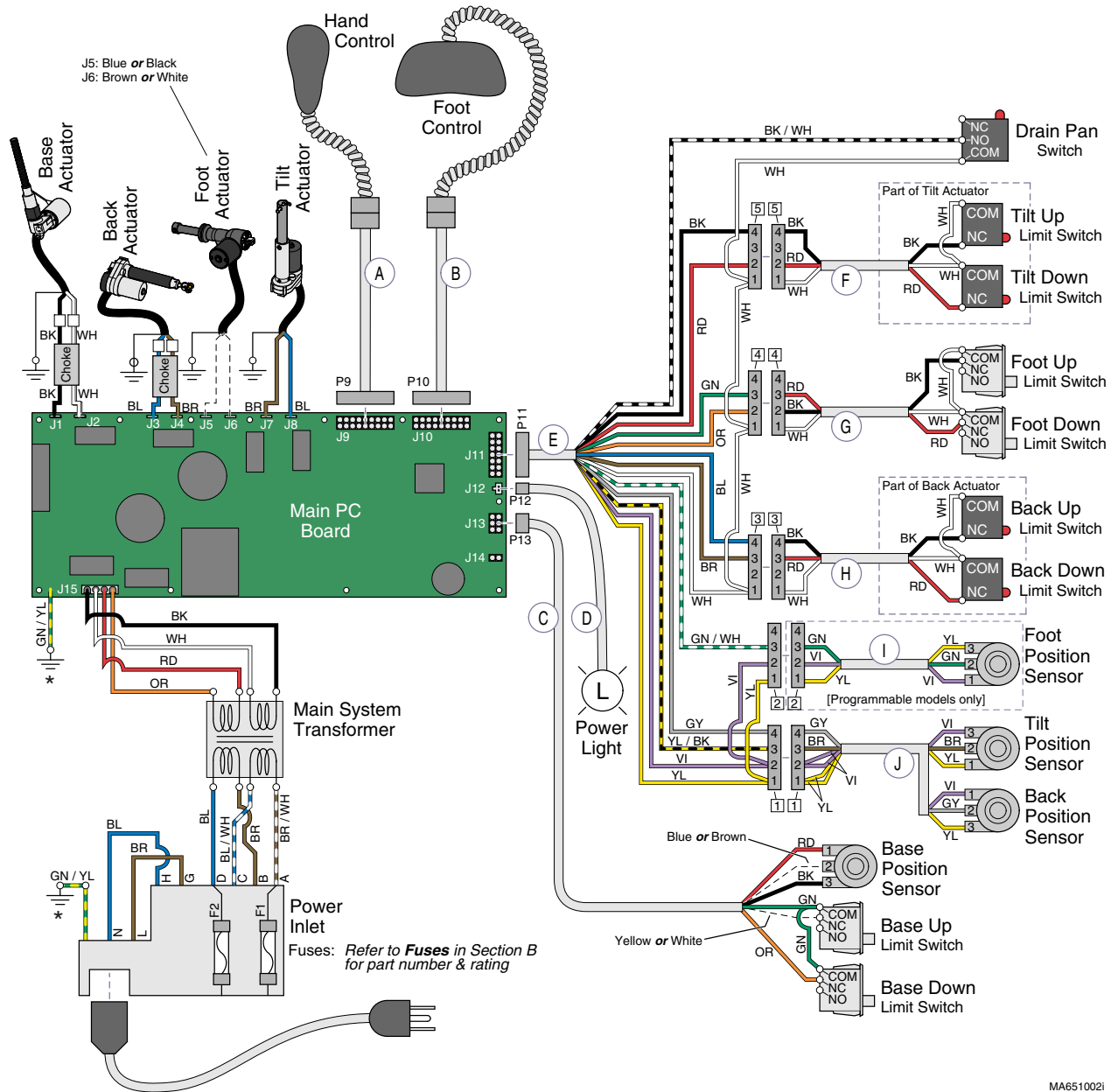

* Ground Wire p/n: 015-1774-03

MA6510021

Wiring Diagrams

Models:
Serial Numbers:

Non-Programmable
630 (-001)
V76348 thru Present

Programmable
630 (-002)
V77340 thru Present

Wiring Diagrams

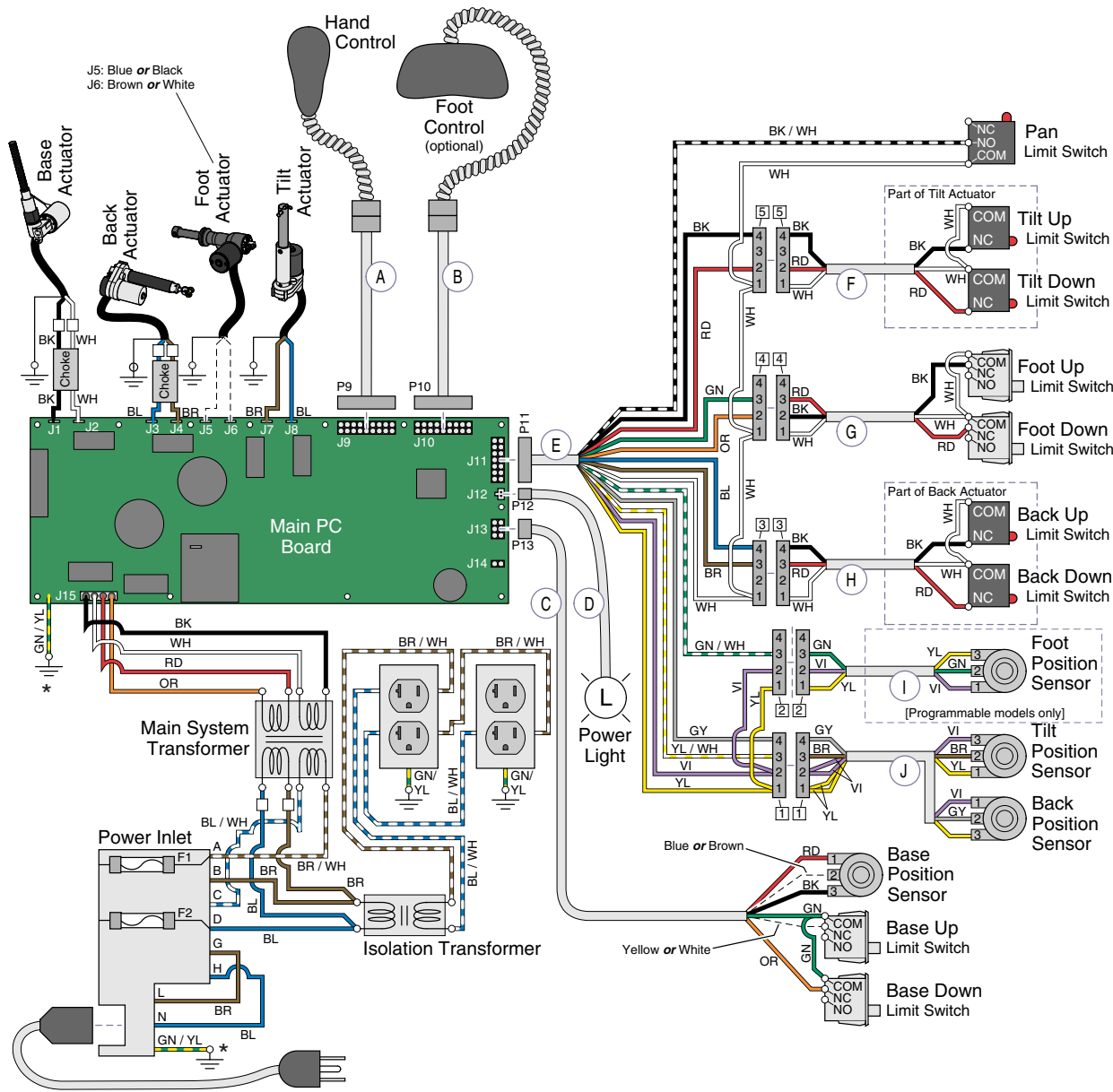

Refer To:
 Primary Fuses B-2

Item	Harness Description (sensors & switches not included)	Part Number
A	Connection Port Harness [short - head end]	002-1110-00
B	Connection Port Harness [long - foot end]	002-1110-01
C	Position Sensor / Limit Switch Harness - BASE	015-1821-00
D	Power Light Harness [includes green light]	015-1793-00
E	'PC Board to Junction Board' Harness	015-1746-00
F	Tilt Limit Switch Harness	n/a (part of Tilt actuator)
G	Foot Limit Switch Harness	015-1731-00
H	Back Limit Switch Harness	n/a (part of Back actuator)
I	Position Sensor Harness - FOOT [Prog. models only]	015-1773-00 (includes sensor)
J	Position Sensor Harness - TILT & BACK	015-1761-00 (incl. both sensors)

Models:	<i>Non-Programmable</i> 630 (-003 & -008)	<i>Programmable</i> 630 (-004 & -009)	<i>Non-Programmable</i> 75 (-020)	<i>Programmable</i> 75 (-021)
Serial Numbers:	V1000 thru V77350	V1000 thru V77350	V1000 thru V77350	V1000 thru V77350

Wiring Diagrams

Wiring Diagrams

Refer To:

Primary Fuses

Page

B-2

Item	Harness Description <i>(sensors & switches not included)</i>	Part Number
A	Connection Port Harness <i>[short - head end]</i>	002-1110-00
B	Connection Port Harness <i>[long - foot end]</i>	002-1110-01
C	Position Sensor / Limit Switch Harness - BASE	015-1821-00
D	Power Light Harness <i>[includes green light]</i>	015-1793-00
E	'PC Board to Junction Board' Harness	015-1937-00
F	Tilt Limit Switch Harness	n/a <i>(part of Tilt actuator)</i>
G	Foot Limit Switch Harness	015-1731-00
H	Back Limit Switch Harness	n/a <i>(part of Back actuator)</i>
I	Position Sensor Harness - FOOT <i>[Prog. models only]</i>	015-1773-00 <i>(includes sensor)</i>
J	Position Sensor Harness - TILT & BACK	015-1761-00 <i>(incl. both sensors)</i>

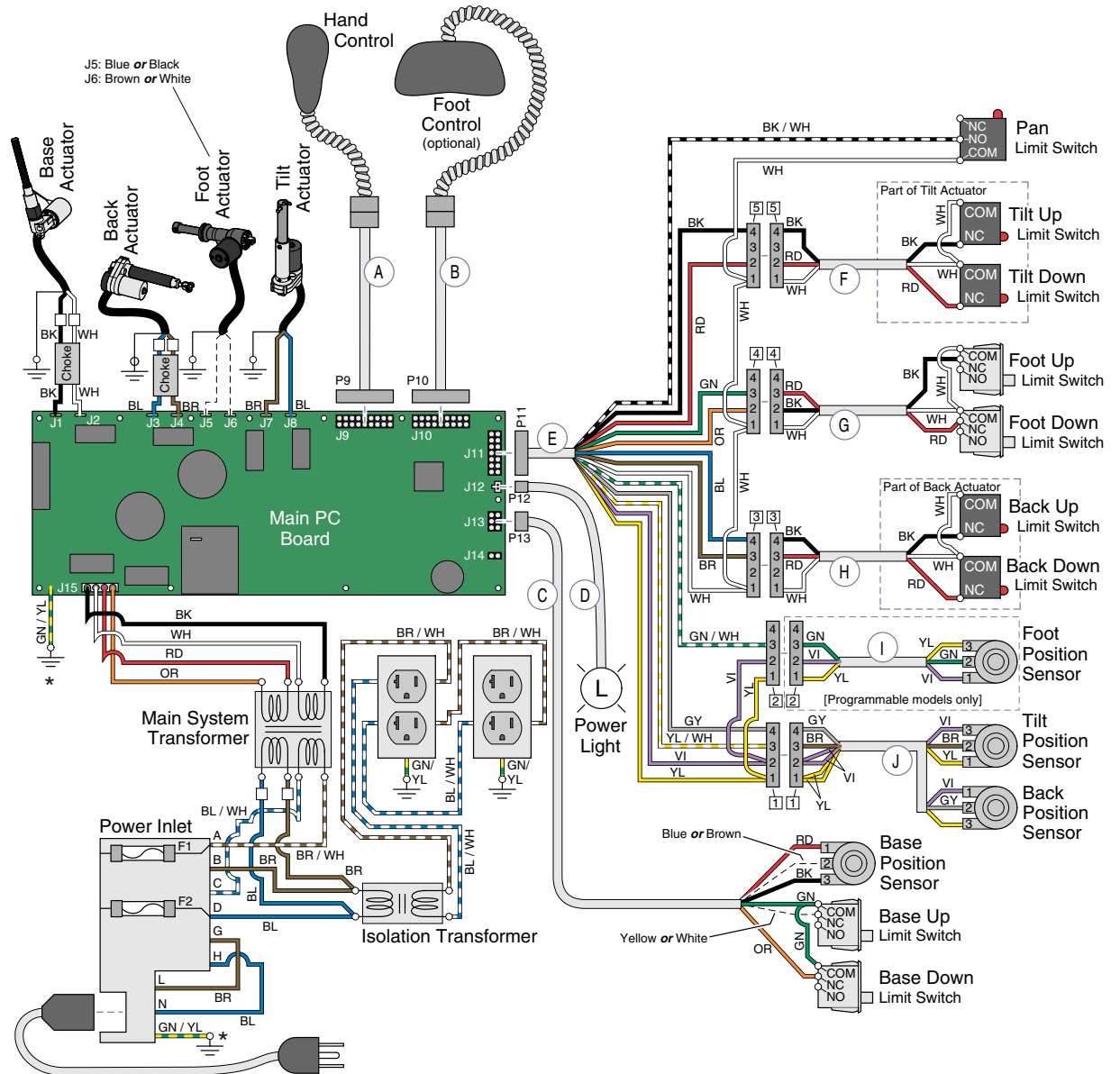

* Ground Wire p/n: 015-1774-03

MA6509011

Wiring Diagrams

D-6.1

Models:
Serial Numbers:

Non-Programmable
630 (-003 & -008)
V77351 thru Present

Programmable
630 (-004 & -009)
V77351 thru Present

Non-Programmable
75 (-020)
V77351 thru Present

Programmable
75 (-021)
V77351 thru Present

Wiring Diagrams

Refer To:

Page

Primary Fuses B-2

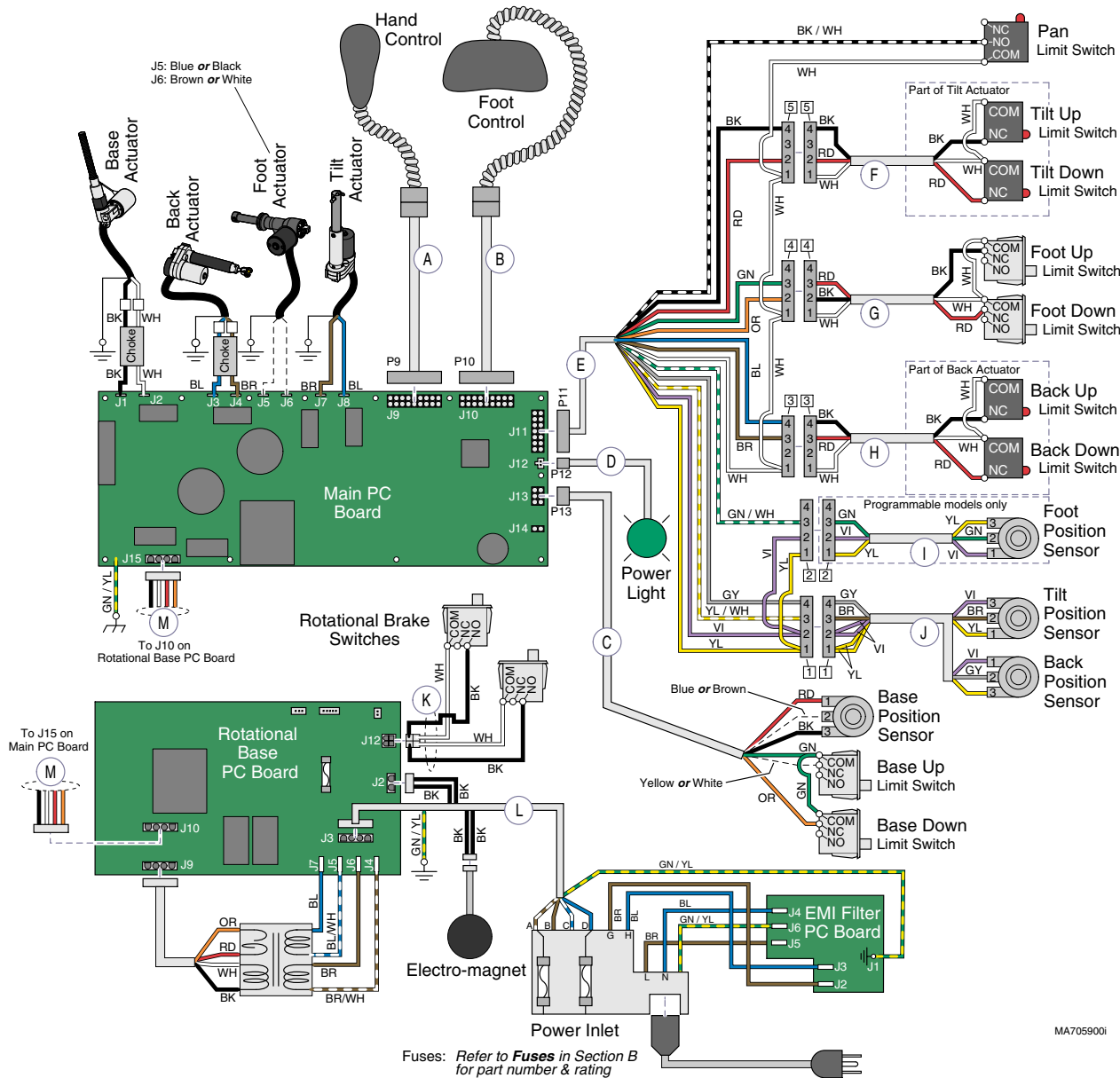

Item	Harness Description <i>(sensors & switches not included)</i>	Part Number
A	Connection Port Harness <i>[short - head end]</i>	002-1110-02
B	Connection Port Harness <i>[long - foot end]</i>	002-1110-03
C	Position Sensor / Limit Switch Harness - BASE	015-1821-00
D	Power Light Harness <i>[includes green light]</i>	015-1793-01
E	'PC Board to Junction Board' Harness	015-1937-00
F	Tilt Limit Switch Harness	n/a <i>(part of Tilt actuator)</i>
G	Foot Limit Switch Harness	015-1731-00
H	Back Limit Switch Harness	n/a <i>(part of Back actuator)</i>
I	Position Sensor Harness - FOOT <i>[Prog. models only]</i>	015-1773-00 <i>(includes sensor)</i>
J	Position Sensor Harness - TILT & BACK	015-1761-00 <i>(incl. both sensors)</i>
K	Brake Switch Harness	015-1967-00
L	Rotational Base PC Board - Power Inlet	015-1966-00
M	Rotational Base PC Board - Main PC Board	015-1968-00

Models:
Serial Numbers:

Non-Programmable
630 (-005)
All

Programmable
630 (-006)
All

Wiring Diagrams

D-7

Wiring Diagrams

Refer To:

Primary Fuses

Page

B-2

Item	Harness Description <i>(sensors & switches not included)</i>	Part Number
A	Connection Port Harness [short - head end]	002-1110-00
B	Connection Port Harness [long - foot end]	002-1110-01
C	Position Sensor / Limit Switch Harness - BASE	015-1821-00
D	Power Light Harness <i>[includes green light]</i>	015-1793-00
E	'PC Board to Junction Board' Harness	015-1937-00
F	Tilt Limit Switch Harness	n/a <i>(part of Tilt actuator)</i>
G	Foot Limit Switch Harness	015-1731-00
H	Back Limit Switch Harness	n/a <i>(part of Back actuator)</i>
I	Position Sensor Harness - FOOT [Prog. models only]	015-1773-00 <i>(includes sensor)</i>
J	Position Sensor Harness - TILT & BACK	015-1761-00 <i>(incl. both sensors)</i>
K	Uph. Heater PC Board - Uph. Heaters - Main PC Board	015-1871-00
L	Uph. Heater PC Board - Power Inlet	015-1870-00
M	Uph. Heater Light Harness <i>(includes light)</i>	015-1938-00

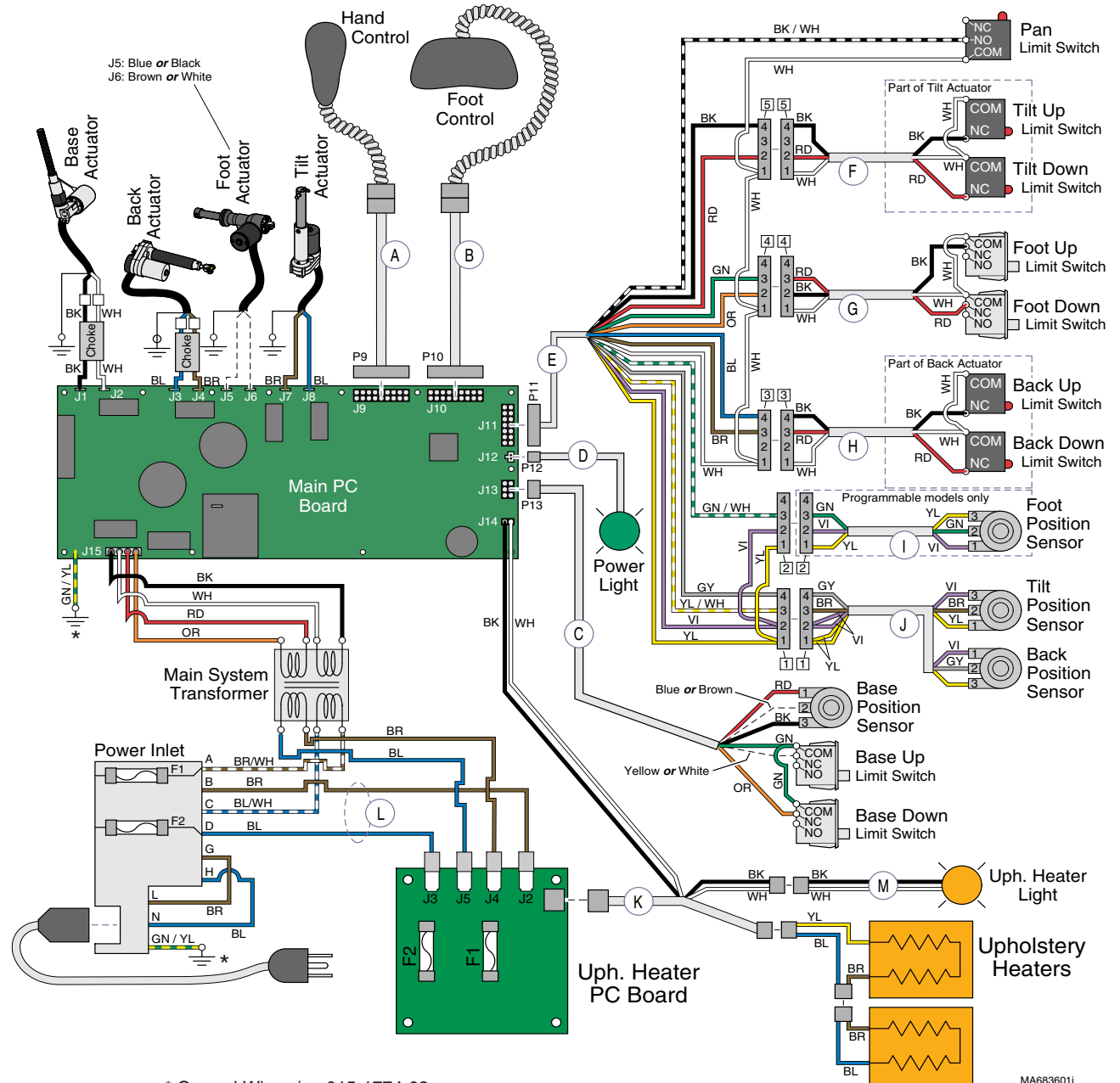

* Ground Wire p/n: 015-1774-03

MA6836011

Section E

Exploded Views & Parts Lists

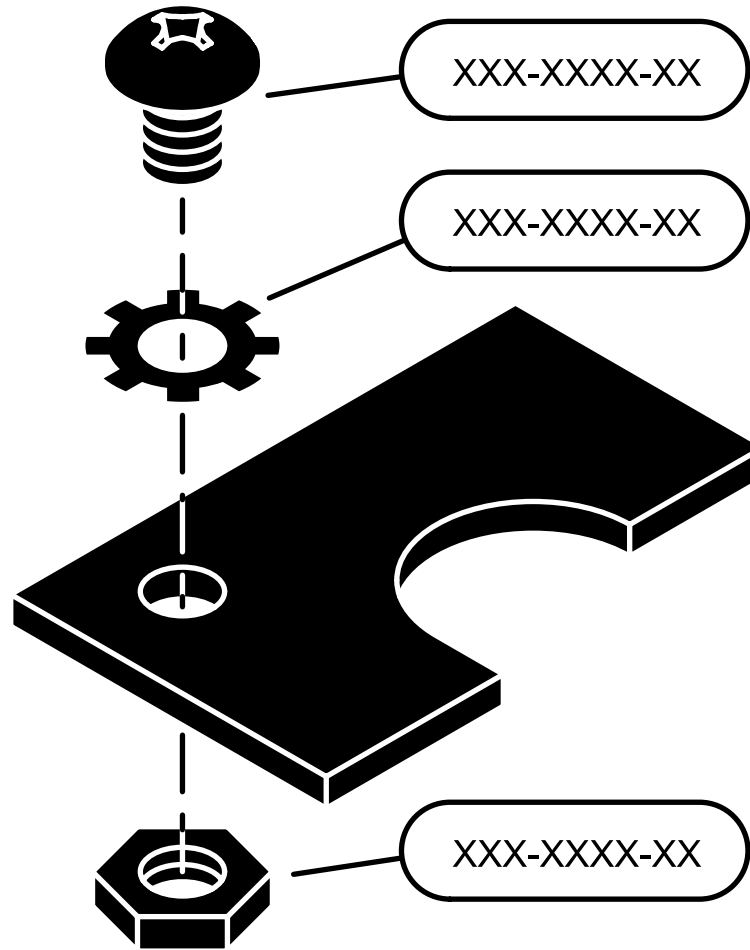

<u>Model</u>	<u>Page</u>
230	E-2
630	E-3
75:	
(-019)	E-2
(-020 / -021)	E-3

230(all) / 75(-019)

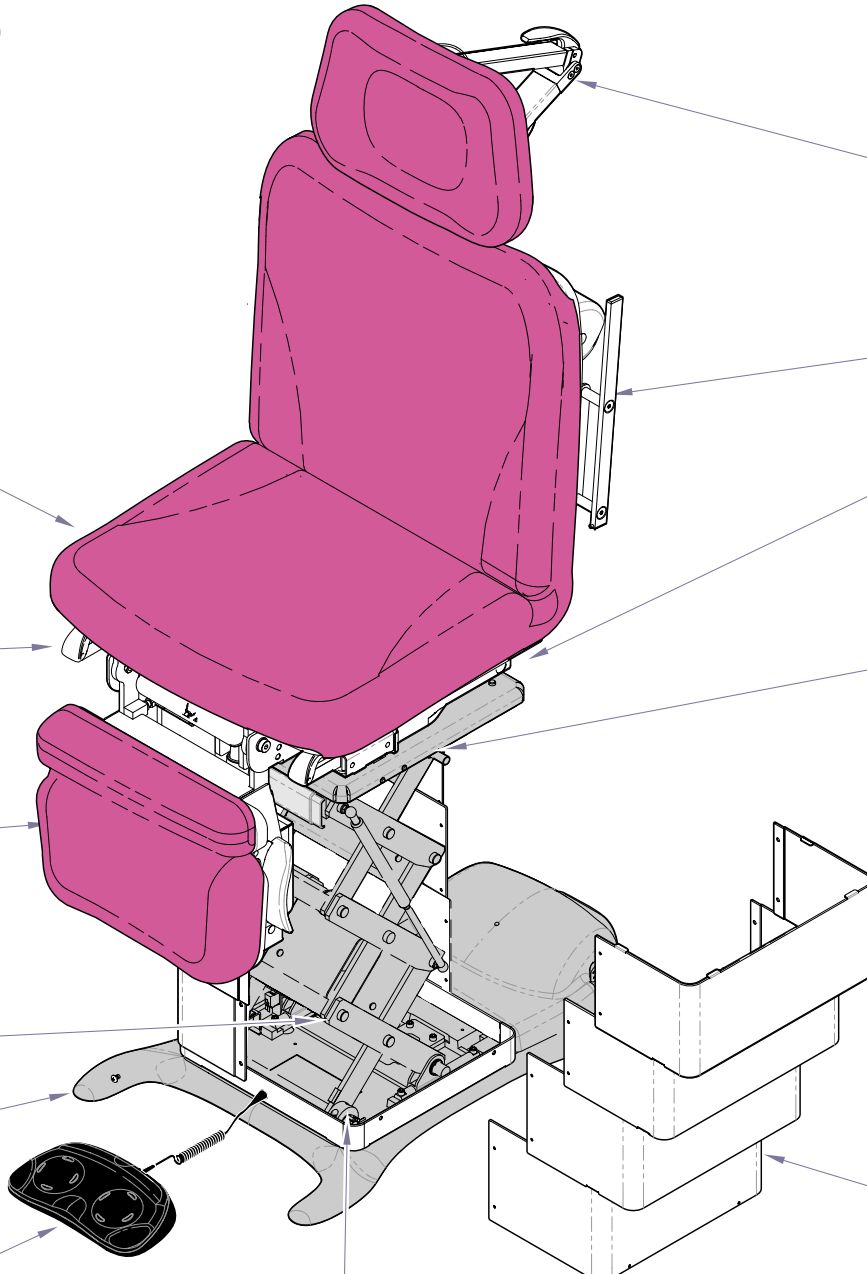

Hand Control E-22

Ritter Upholstery E-6

Stirrup Components E-14

Foot Section:
Ritter Models E-8
includes:
foot actuator & limit switches

Base Actuator E-24

Base Section Components E-19
includes:
PC Board cover & base casting

Foot Control:
Disc-style E-20*
Linear-style E-21

Scissor Components E-18
includes:
base limit switches & gas springs

Headlock Assembly E-13

Back Section:
Ritter Models E-12*
includes:
back actuator & paper roll holder

Seat Section:
Ritter Models E-10
includes:
pan limit switch & treatment pan

Column Top Components E-17
includes:
tilt actuator & wire routing strap

Electrical Components E-23
includes:
PC board, power cord, & fuses

Label Location E-27

Base Shrouds:
Ritter Models E-16

OPTIONAL FEATURES
Table Receptacles E-26
Rotational Base:
Lower Section E-29
Upper Section E-30

* Indicates multiple pages due to a serial number break for the parts illustration

630(all) / 75(-020/-021)

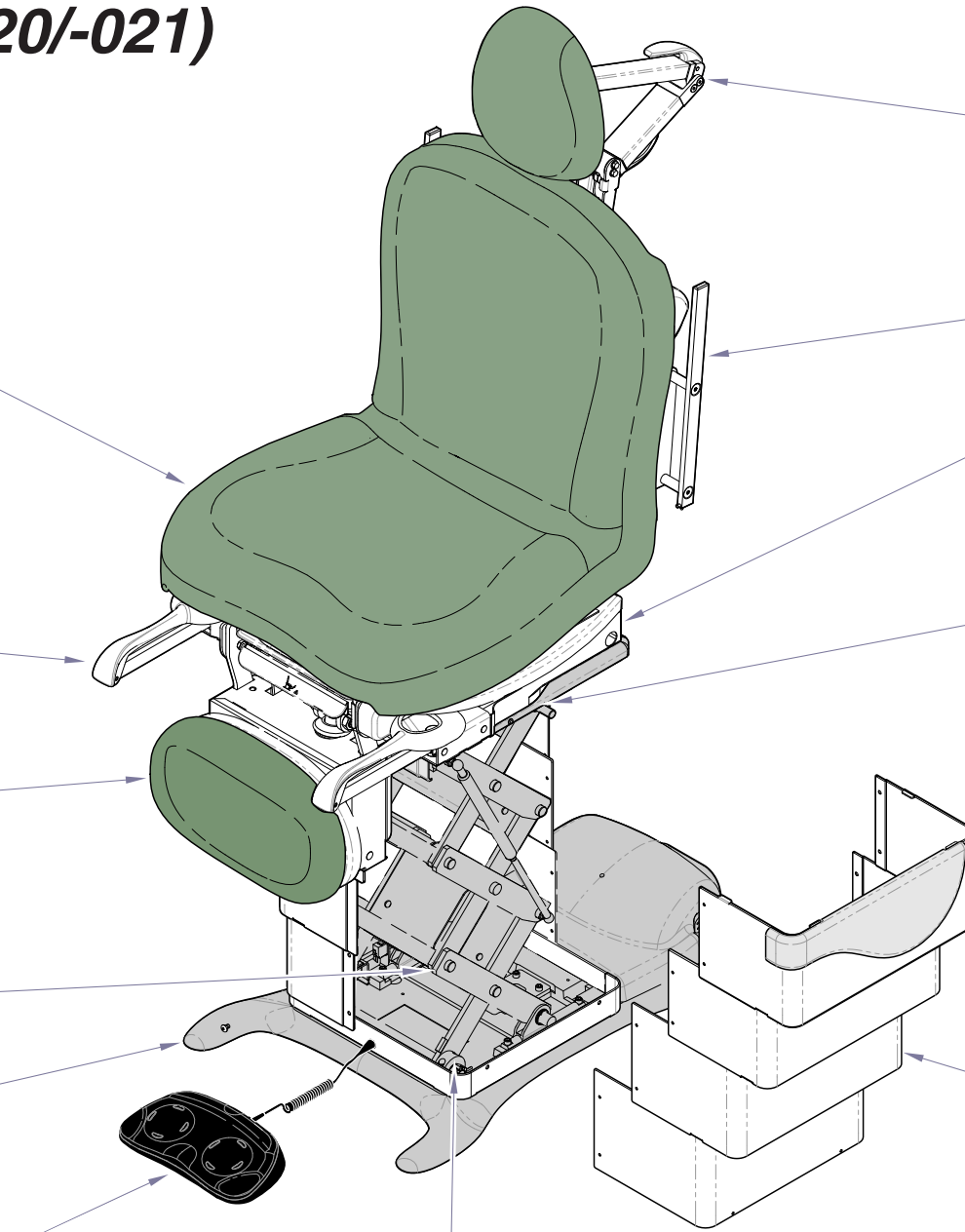

Hand Control E-22

Midmark Upholstery:
Premium E-4
Ultra-Premium E-5

Position Sensors E-25

Stirrup Components E-14

Foot Section:
Midmark Models E-7
includes:
foot actuator & limit switches

Base Actuator E-24

Base Section Components E-19
includes:
PC Board cover & base casting

Foot Control:
Disc-style E-20*
Linear-style E-21

Scissor Components E-18
includes:
base limit switches & gas springs

Headlock Assembly E-13

Back Section:
Midmark Models E-11*
includes:
back actuator & paper roll holder

Seat Section:
Midmark Models E-9*
includes:
pan limit switch & treatment pan

Column Top Components E-17
includes:
tilt actuator & wire routing strap

Electrical Components E-23
includes:
PC board, power cord, & fuses

Label Location:
Midmark Models E-27

Base Shrouds:
Midmark Models E-15

OPTIONAL FEATURES
 Table Receptacles E-26
 Htd Uph. PC Board E-28*
 Rotational Base:
 Lower Section E-29
 Upper Section E-30

* Indicates multiple pages due to a serial number break for the parts illustration

Refer To:
 Color Selector www.midmark.com

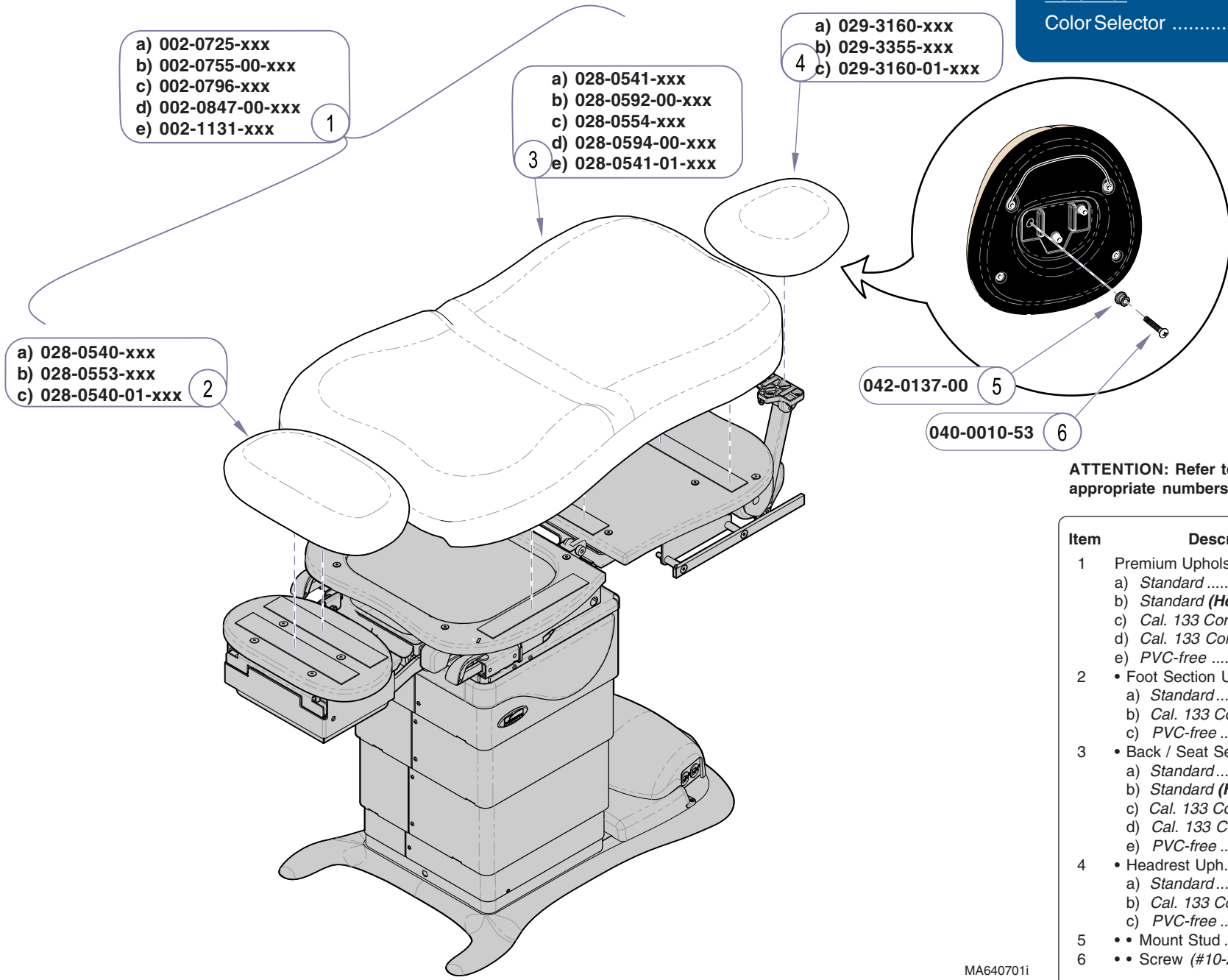

- 1
- a) 002-0725-xxx
 - b) 002-0755-00-xxx
 - c) 002-0796-xxx
 - d) 002-0847-00-xxx
 - e) 002-1131-xxx

- 3
- a) 028-0541-xxx
 - b) 028-0592-00-xxx
 - c) 028-0554-xxx
 - d) 028-0594-00-xxx
 - e) 028-0541-01-xxx

- 4
- a) 029-3160-xxx
 - b) 029-3355-xxx
 - c) 029-3160-01-xxx

- 2
- a) 028-0540-xxx
 - b) 028-0553-xxx
 - c) 028-0540-01-xxx

042-0137-00 5

040-0010-53 6

ATTENTION: Refer to *Color Selector* link for appropriate numbers to replace -xxx.

Item	Description	Qty.
1	Premium Upholstery Kit (incl. items 2 thru 4):	
	a) Standard	1
	b) Standard (Heated)	1
	c) Cal. 133 Compliant	1
	d) Cal. 133 Compliant (Heated)	1
	e) PVC-free	1
2	• Foot Section Uph.	
	a) Standard	1
	b) Cal. 133 Compliant	1
	c) PVC-free	1
3	• Back / Seat Section Uph.	
	a) Standard	1
	b) Standard (Heated)	1
	c) Cal. 133 Compliant	1
	d) Cal. 133 Compliant (Heated)	1
	e) PVC-free	1
4	• Headrest Uph. (incl. items 5 & 6)	
	a) Standard	1
	b) Cal. 133 Compliant	1
	c) PVC-free	1
5	• • Mount Stud	3
6	• • Screw (#10-24 x 1 1/4")	3

Always Specify Model & Serial Number

MA640701i

Refer To:
Color Selector www.midmark.com

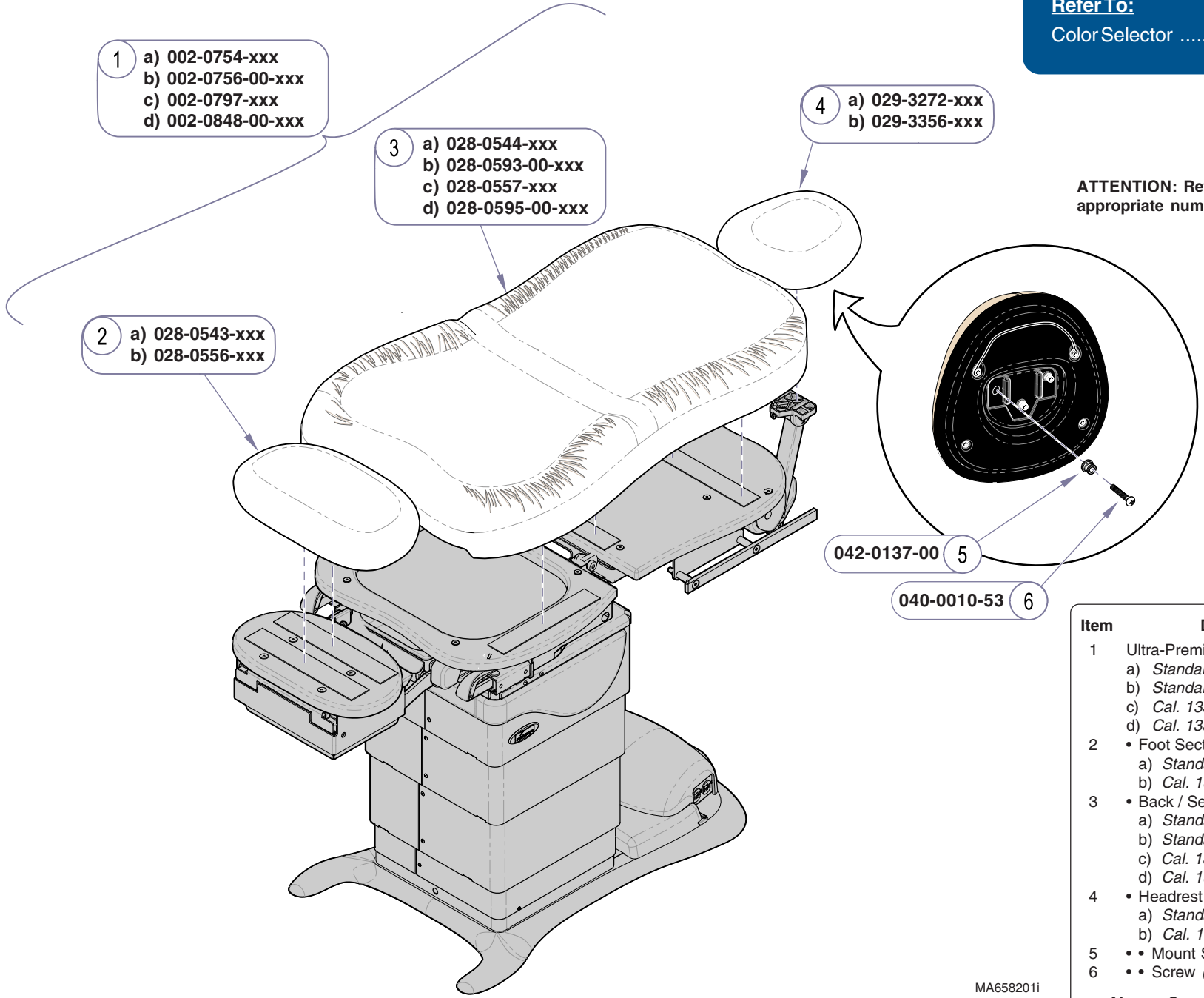

ATTENTION: Refer to *Color Selector* link for appropriate numbers to replace -xxx.

- 1 a) 002-0754-xxx
b) 002-0756-00-xxx
c) 002-0797-xxx
d) 002-0848-00-xxx

- 3 a) 028-0544-xxx
b) 028-0593-00-xxx
c) 028-0557-xxx
d) 028-0595-00-xxx

- 4 a) 029-3272-xxx
b) 029-3356-xxx

- 2 a) 028-0543-xxx
b) 028-0556-xxx

042-0137-00 5

040-0010-53 6

Item	Description	Qty.
1	Ultra-Premium Uph. Kit (incl. items 2 thru 4):	
	a) Standard	1
	b) Standard (Heated)	1
	c) Cal. 133 Compliant	1
	d) Cal. 133 Compliant (Heated)	1
2	• Foot Section Uph.	
	a) Standard	1
	b) Cal. 133 Compliant	1
3	• Back / Seat Section Uph.	
	a) Standard	1
	b) Standard (Heated)	1
	c) Cal. 133 Compliant	1
	d) Cal. 133 Compliant (Heated)	1
4	• Headrest Uph.	
	a) Standard	1
	b) Cal. 133 Compliant	1
5	• • Mount Stud	3
6	• • Screw (#10-24 x 1 1/4")	3

Always Specify Model & Serial Number

MA658201i

Models:	630 (all)	75 (-020/-021)
Serial Numbers:	All	All

Midmark Upholstery:
Ultra-Premium

Standard Width Upholstery

(27 in. wide)

Refer To:

Color Selector www.midmark.com

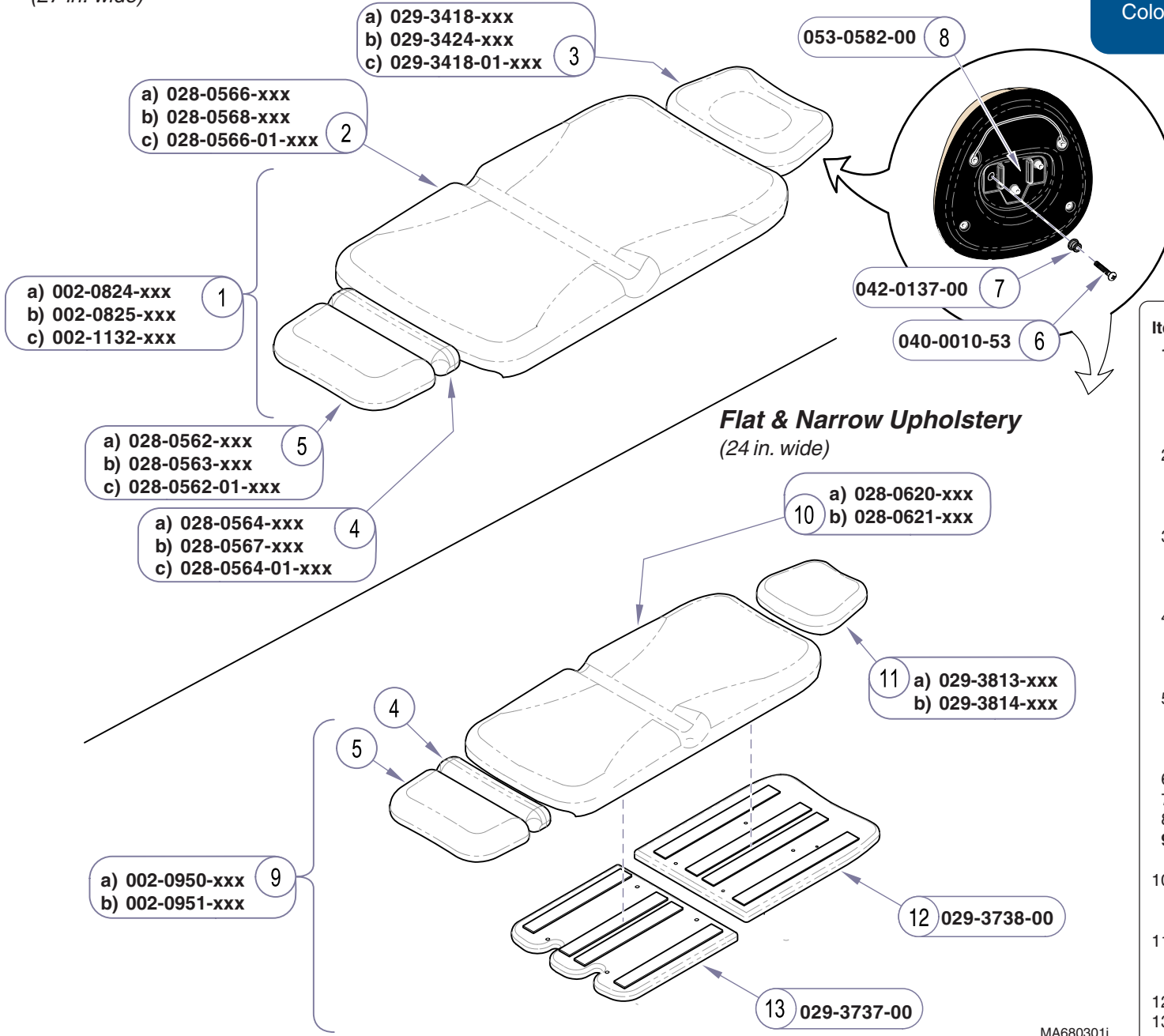

ATTENTION: Refer to *Color Selector* link for appropriate numbers to replace -xxx.

Item	Description	Qty.
1	Ritter Upholstery Kit - Standard Width (incl. items 2 thru 7):	
	a) Standard	1
	b) Cal. 133 Compliant	1
	c) PVC-free	1
2	• Back / Seat Upholstery.	
	a) Standard	1
	b) Cal. 133 Compliant	1
	c) PVC-free	1
3	• Headrest Upholstery	
	a) Standard	1
	b) Cal. 133 Compliant	1
	c) PVC-free	1
4	• Thigh Upholstery.	
	a) Standard	1
	b) Cal. 133 Compliant	1
	c) PVC-free	1
5	• Foot Upholstery	
	a) Standard	1
	b) Cal. 133 Compliant	1
	c) PVC-free	1
6	• Screw	3
7	• Upholstery Mount Stud	3
8	• Headboard Pillow Mount	1
9	Ritter Flat & Narrow Upholstery Kit (incl. items 4 thru 7 & 9 thru 12)	1
10	• Back / Seat Upholstery - Narrow	
	a) Standard	1
	b) Cal. 133 Compliant	1
11	• Headrest Upholstery - Narrow	
	a) Standard	1
	b) Cal. 133 Compliant	1
12	• Back Support Board - Narrow	1
13	• Seat Support Board - Narrow	1

Always Specify Model & Serial Number

MA680301i

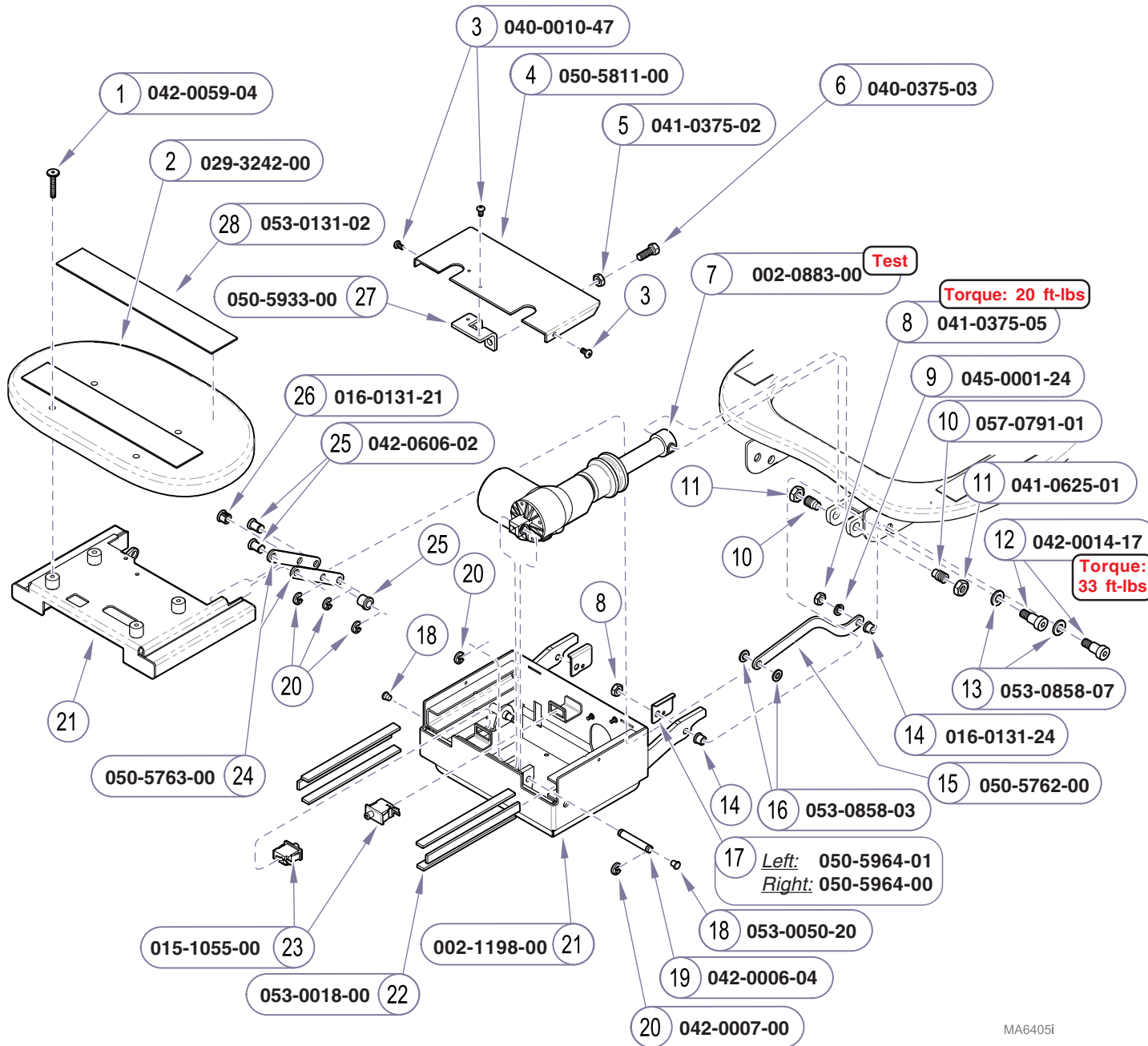

NOTE
Actuator kit includes a grounding harness (015-0737-22). The grounding harness is required on early models only.

Item	Description	Qty.
1	Bolt (1/4-20 x 1.575)	4
2	Foot Pad Mounting Board (incl. velcro)	1
3	Screw (#10-24 x 3/8")	4
4	Top Foot Cover	1
5	Nut (3/8-16)	2
6	Bolt (3/8-16 x 1")	2
7	Foot Actuator Kit (see NOTE)	1
8	Nut (3/8"-16)	2
9	Lock Washer	2
10	Pivot Screw	2
11	Jam Nut (5/8"-11)	2
12	Shoulder Screw (1/2" x 3/8")	4
13	Nylon Washer (3/4" x 1/2" x 1/8")	3
14	Flange Bearing	4
15	Seat Weldment Link	2
16	Nylon Washer (5/8" x 3/8" x 1/32")	4
17	Restraint Bracket	2
18	Hole Plug	2
19	Clevis Pin	1
20	E-ring (3/8" diameter)	8
21	Foot Weldment Assembly	1
22	Limit Switch	AR
23	Nylon Tape (42" required)	2
24	Pivot Link	4
25	Clevis Pin	4
26	Flange Bearing	4
27	Adjustable Limit Switch Bracket	1
28	Velcro Hook	2

Always Specify Model & Serial Number

Models: 630 (all) 75 (-020/-021)
Serial Numbers: V1000 thru V717499 V1000 thru V717499

Foot Section:
Midmark Models

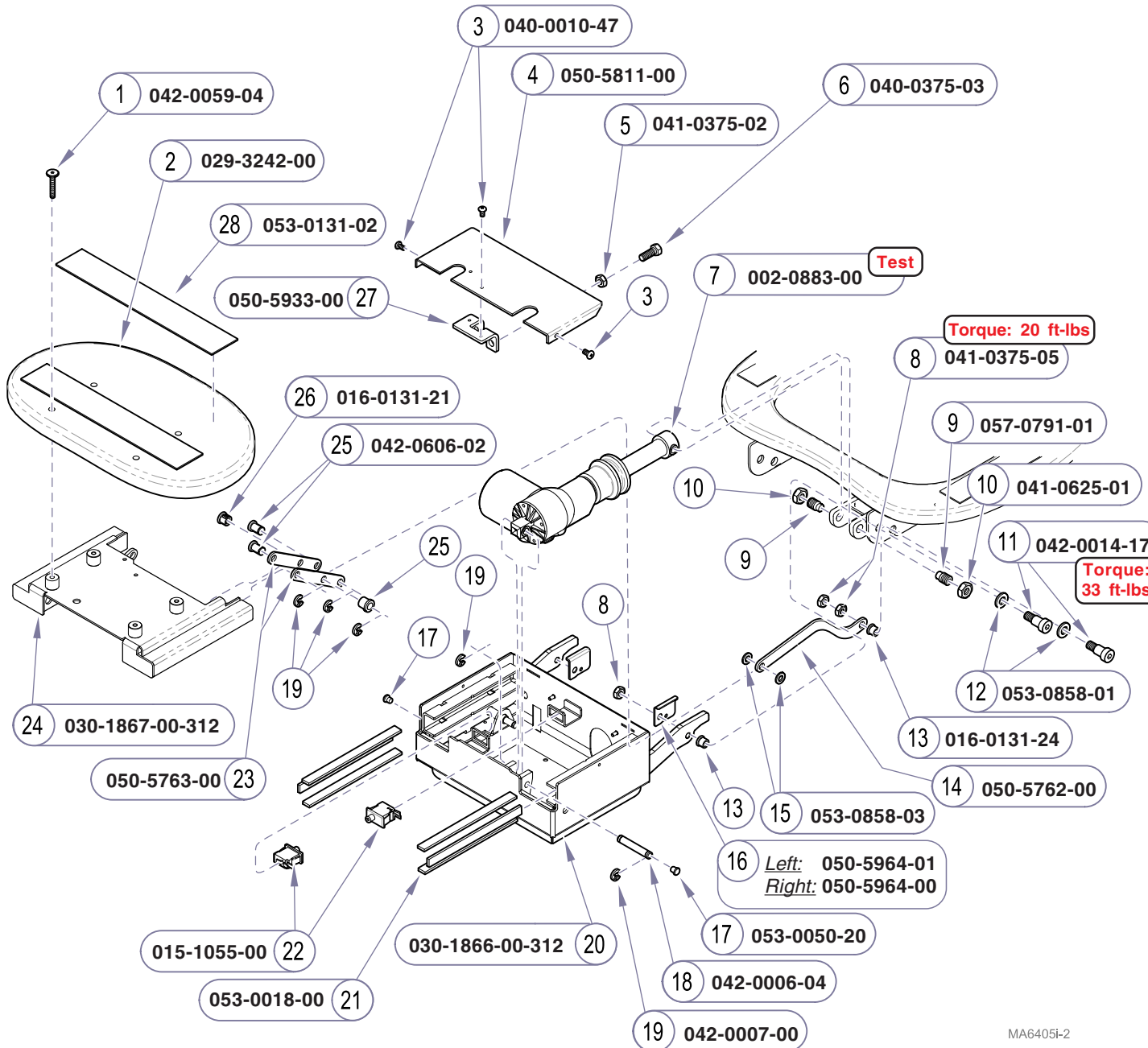

NOTE
 Actuator kit includes a grounding harness (015-0737-22). The grounding harness is required on early models only.

Item	Description	Qty.
1	Bolt (1/4-20 x 1.575)	4
2	Foot Pad Mounting Board (incl. velcro)	1
3	Screw (#10-24 x 3/8")	4
4	Top Foot Cover	1
5	Nut (3/8-16)	2
6	Bolt (3/8-16 x 1")	2
7	Foot Actuator Kit (see NOTE)	1
8	Nut (3/8-16)	6
9	Pivot Screw	2
10	Jam Nut (5/8-11)	2
11	Shoulder Screw (1/2" x 3/8")	4
12	Nylon Washer (3/4" x 1/2" x 1/8")	3
13	Flange Bearing	4
14	Seat Weldment Link	2
15	Nylon Washer (5/8" x 3/8" x 1/32")	4
16	Restraint Bracket	2
17	Hole Plug	2
18	Clevis Pin	1
19	E-ring (3/8" diameter)	8
20	Foot Weldment	1
21	Nylon Tape (42" required)	AR
22	Limit Switch	2
23	Pivot Link	4
24	Foot Extension Weldment	1
25	Clevis Pin	4
26	Flange Bearing	4
27	Adjustable Limit Switch Bracket	1
28	Velcro Hook	2

Always Specify Model & Serial Number

Models: 630 (all) 75 (-020/-021)
Serial Numbers: V730707 thru Present V730707 thru Present

Foot Section:
 Midmark Models

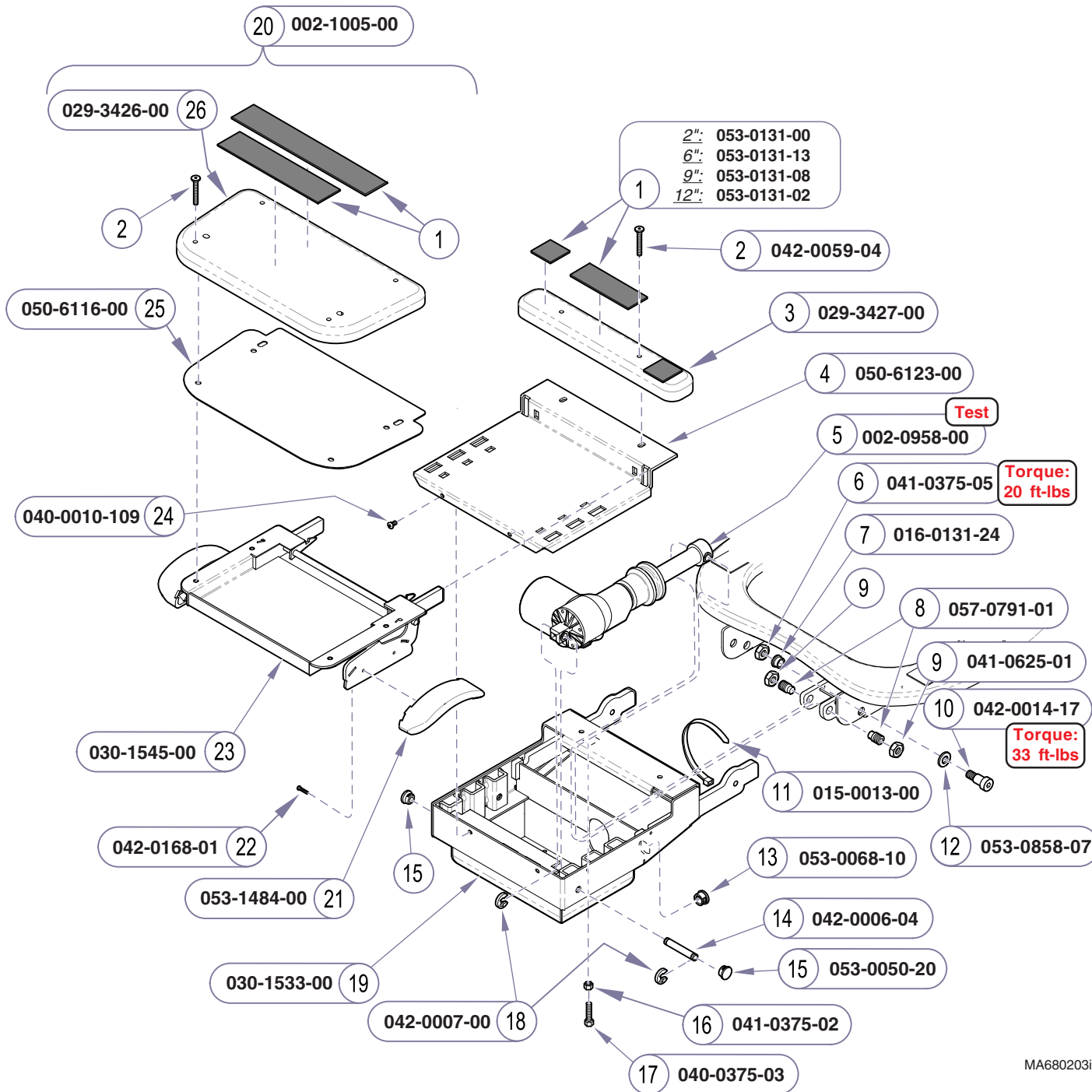

MA680203i

Item	Description	Qty.
1	Velcro Hook (lengths are listed)	AR
2	JC Bolt (1/4"-20 x 1")	6
3	Thigh Pad Mounting Board (includes velcro strips)	1
4	Foot Trim Cover	1
5	Foot Actuator Kit	1
6	Nut (3/8"-016)	2
7	Flange Bearing	2
8	Pivot Screw	2
9	Jam Nut (5/8"-11)	2
10	Shoulder Bolt (1/2" x 3/8")	2
11	Cable Tie (7 1/4" long)	2
12	Nylon Washer (3/4" x 1/2" x 1/8")	2
13	Snap Bushing	1
14	Clevis Pin	1
15	Hole Plug	2
16	Jam Nut (3/8"-16)	1
17	Bolt (3/8" -16 x 1)	1
18	E-ring (3/8")	2
19	Foot Weldment	1
20	Knee Rest Assembly Kit (includes items 2, & 21 thru 26)	1
21	• Release Handle	2
22	• Screw (3.5-1.57 a 16 atf pt zn)	4
23	• Knee / Chest Weldment	1
24	• Screw (#10-24 x 3/8")	2
25	• Foot Substrate Support Plate	1
26	• Foot Pad Mounting Board (includes velcro strips)	1

Always Specify Model & Serial Number

Foot Section:
 Ritter Models

Models: 230 (all)
 Serial Numbers: All

75 (-019)
 All

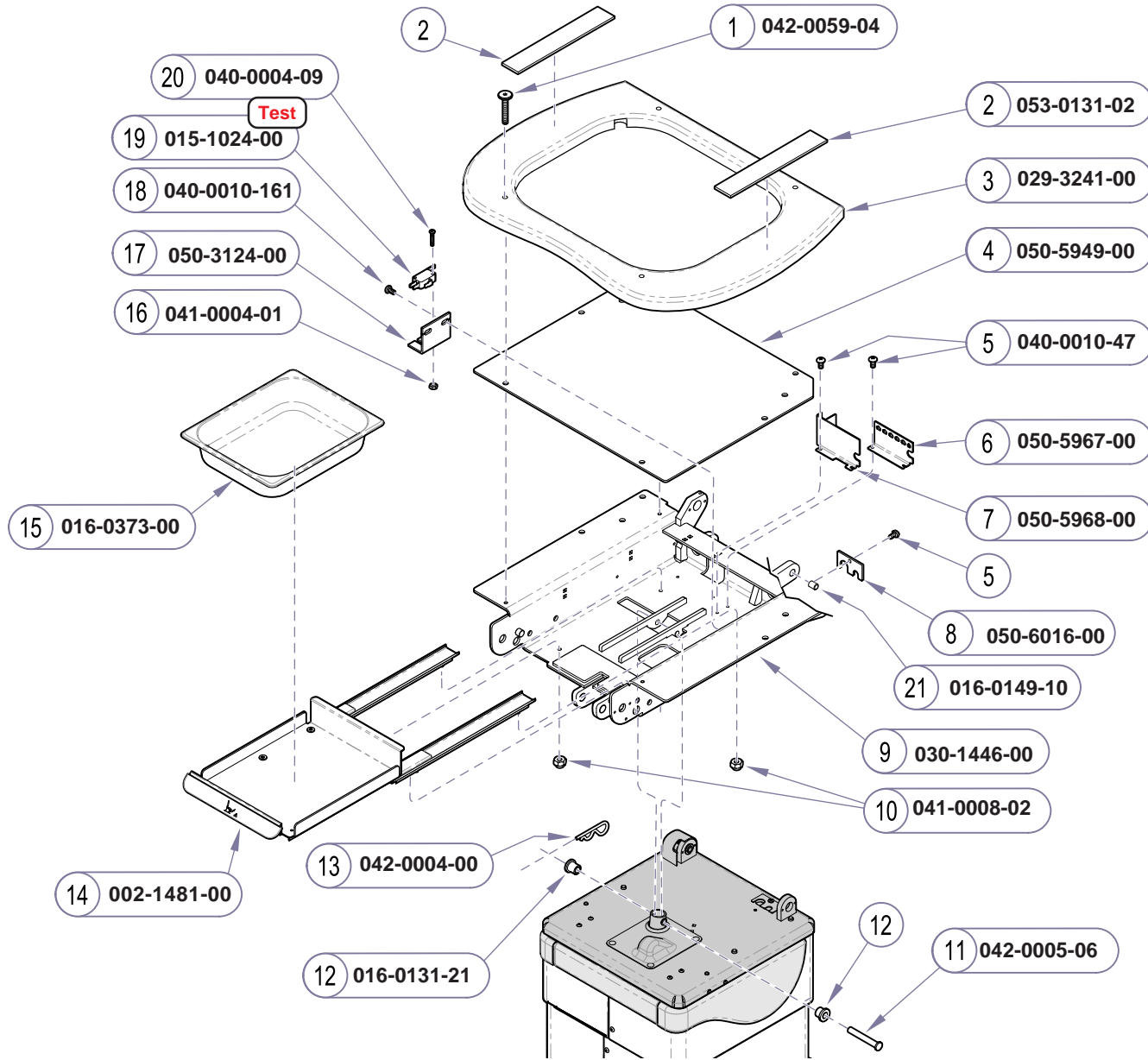

Item	Description	Qty.
1	Bolt (1/4-20 x 1.575")	4
2	Velcro Hook (2" x 12")	2
3	Seat Mounting Board (includes velcro)	1
4	Seat Cushion Support Panel	1
5	Screw (10-24 x 3/8" Phillips Pan Head)	4
6	Electrical Connection Bracket	1
7	Electrical Cover Panel	1
8	Corrugated Tubing Bracket	1
9	Seat Weldment	1
10	Nut (8-32)	4
11	Pin	2
12	Bushing	2
13	Clevis Pin	1
14	Treatment Pan Slide Assembly	1
15	Treatment Pan	1
16	Nut (4-40)	2
17	Limit Switch Bracket	1
18	Screw (10-24 x 1/4" Phillips Pan Head)	2
19	Limit Switch	1
20	Screw (4-40 x 5/8" Phillips Pan Head)	1
21	Bearing	1

Always Specify Model & Serial Number

MA640201

Models:	630 (all)	75 (-020/-021)
Serial Numbers:	V2200 thru V76347	V2200 thru V76347

**Seat Section:
Midmark Models**

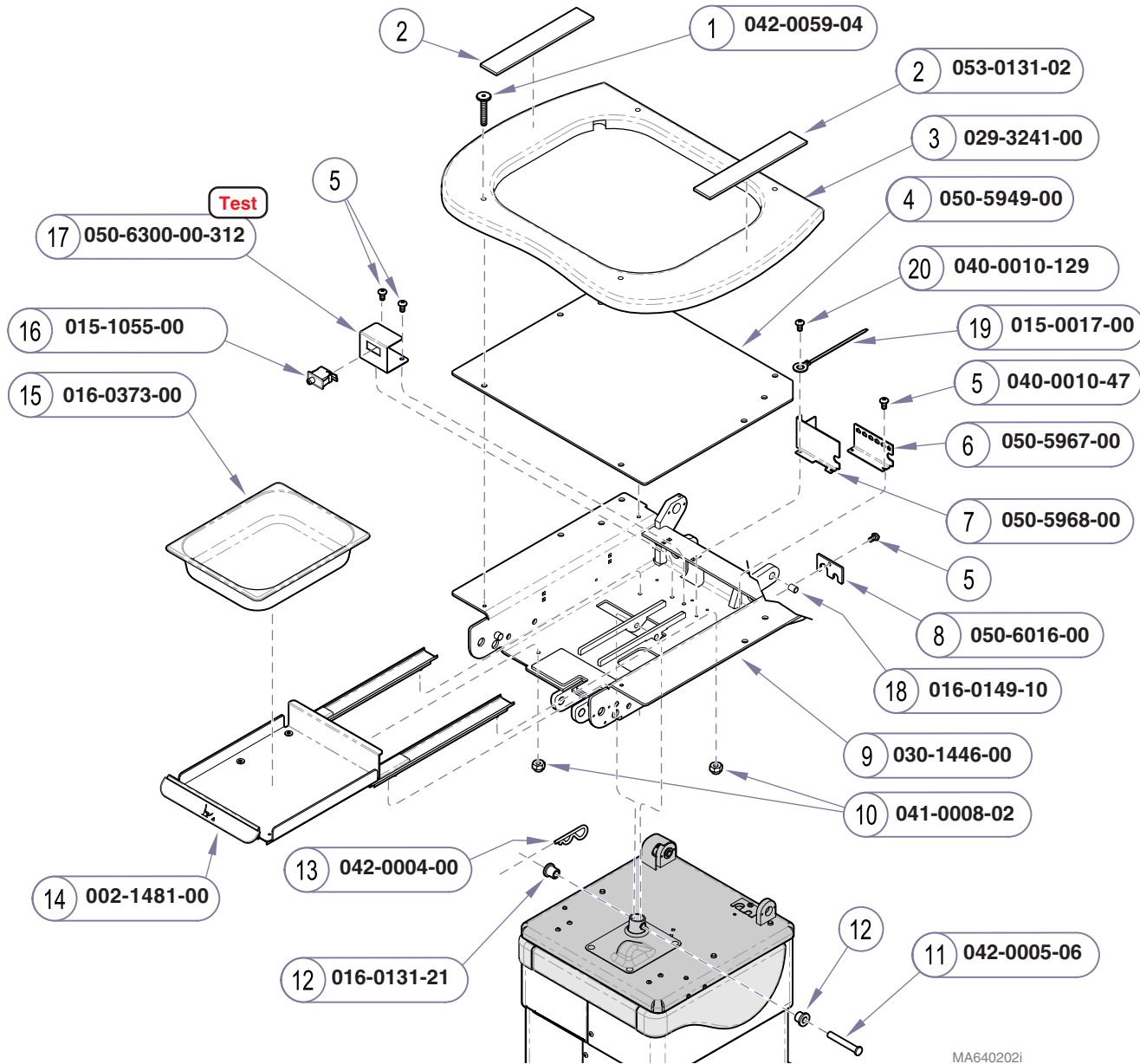

MA640202i

Item	Description	Qty.
1	Bolt (1/4-20 x 1.575")	4
2	Velcro Hook (2" x 12")	2
3	Seat Mounting Board (includes velcro)	1
4	Seat Cushion Support Panel	1
5	Screw (10-24 x 3/8" Phillips Pan Head)	3
6	Electrical Connection Bracket	1
7	Electrical Cover Panel	1
8	Corrugated Tubing Bracket	1
9	Seat Weldment	1
10	Nut (8-32)	4
11	Pin	2
12	Bushing	2
13	Clevis Pin	1
14	Treatment Pan Slide Assembly	1
15	Treatment Pan	1
16	Limit Switch	1
17	Limit Switch Bracket	1
18	Bearing	1
19	Cable Tie	1
20	Screw (10-24 x 1/2" Phillips Pan Head)	1

Always Specify Model & Serial Number

Seat Section:
 Midmark Models

Models: 630 (all)
 Serial Numbers: V76348 thru Present

75 (-020/-021)
 V76348 thru Present

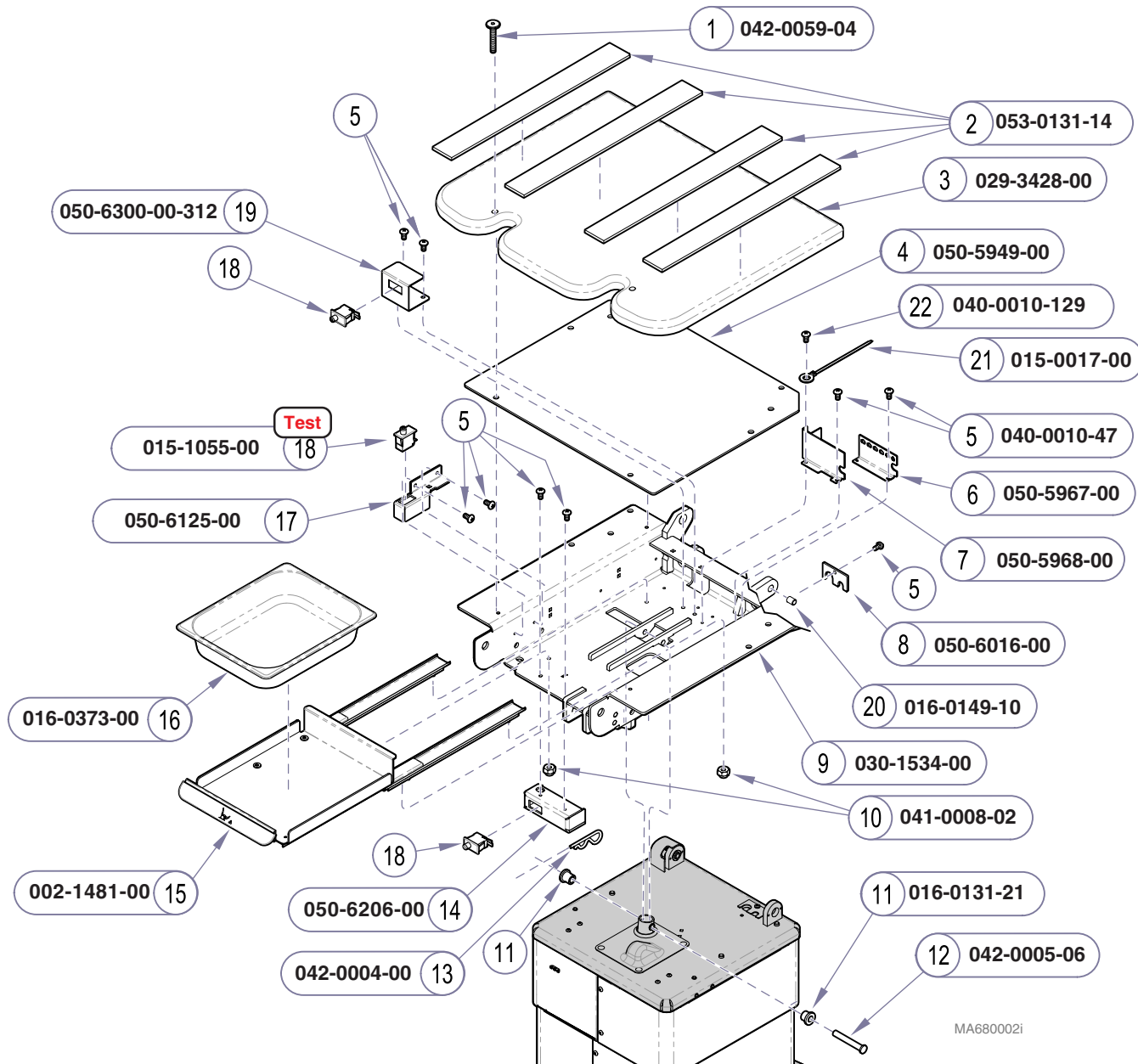

Item	Description	Qty.
1	Bolt (1/4-20 x 1.575")	4
2	Velcro Hook (2" x 12")	2
3	Seat Mounting Board (includes velcro)	1
4	Seat Cushion Support Panel	1
5	Screw (10-24 x 3/8" Phillips Pan Head)	9
6	Electrical Connection Bracket	1
7	Electrical Cover Panel	1
8	Corrugated Tubing Bracket	1
9	Seat Weldment	1
10	Nut (8-32)	4
11	Bushing	2
12	Pin	2
13	Clevis Pin	1
15	Treatment Pan Slide Assembly	1
16	Treatment Pan	1
17	Upper Limit Switch Bracket	1
18	Limit Switch	2
19	Pan Limit Switch Bracket	1
20	Bearing	1
21	Cable Tie	1
22	Screw (10-24 x 1/2" Phillips Pan Head)	1

Always Specify Model & Serial Number

Models: **230 (all)** | **75 (-019)**
 Serial Numbers: All | All

Seat Section:
 Ritter Models

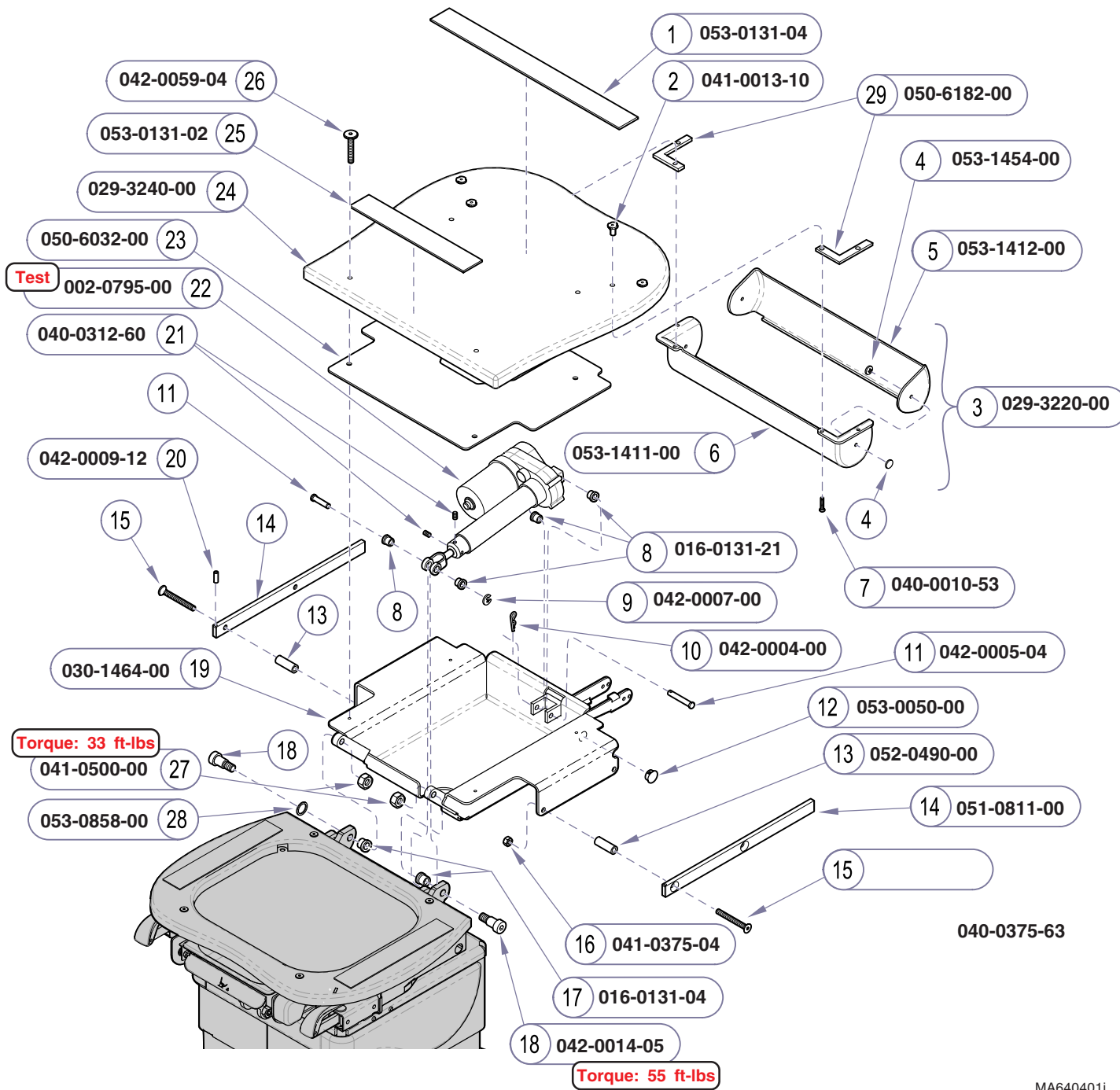

NOTE
 Actuator kit includes the choke & a grounding harness (015-0737-22). The grounding harness is required on early models only.

Item	Description	Qty.
1	Velcro Hook (2" x 20")	1
2	Wood Insert T-Nut	4
3	Paper Roll Holder Assembly (includes items 4 thru 6)	1
4	• Ratchet Rivet	4
5	• Paper Roll Holder Lid	1
6	• Paper Roll Holder	1
7	Screw (#10-24 x 1 1/4" Phillips Pan Head) ..	4
8	Flange Bearing	4
9	E-ring	1
10	Hitch Pin Clip	1
11	Clevis Pin	1
12	Hole Plug	1
13	Spacer	4
14	Side Rail	2
15	Bolt (3/8-16 x 3" Flathead Socket)	4
16	Nut (3/8-16)	4
17	Flange Bearing	2
18	Shoulder Bolt (5/8" x 3/4")	2
19	Back Weldment	1
20	Groove Pin (3/16" x 1/2")	2
21	Set Screw	2
22	Back Actuator Kit (see NOTE)	1
23	Back Assembly Cover	1
24	Back Mounting Board (includes all T-Nuts & velcro)	1
25	Velcro Hook (2" x 12")	1
26	JC Bolt (1/4-20 x 1.575")	4
27	Jam Nut (1/2"-13)	2
28	Washer, nylon	1
29	Spacer	2

Always Specify Model & Serial Number

MA640401i

Back Section:
 Midmark Models

Models: 630 (all)
Serial Numbers: V1000 thru V185140

75 (-020/-021)
 V1000 thru V185140

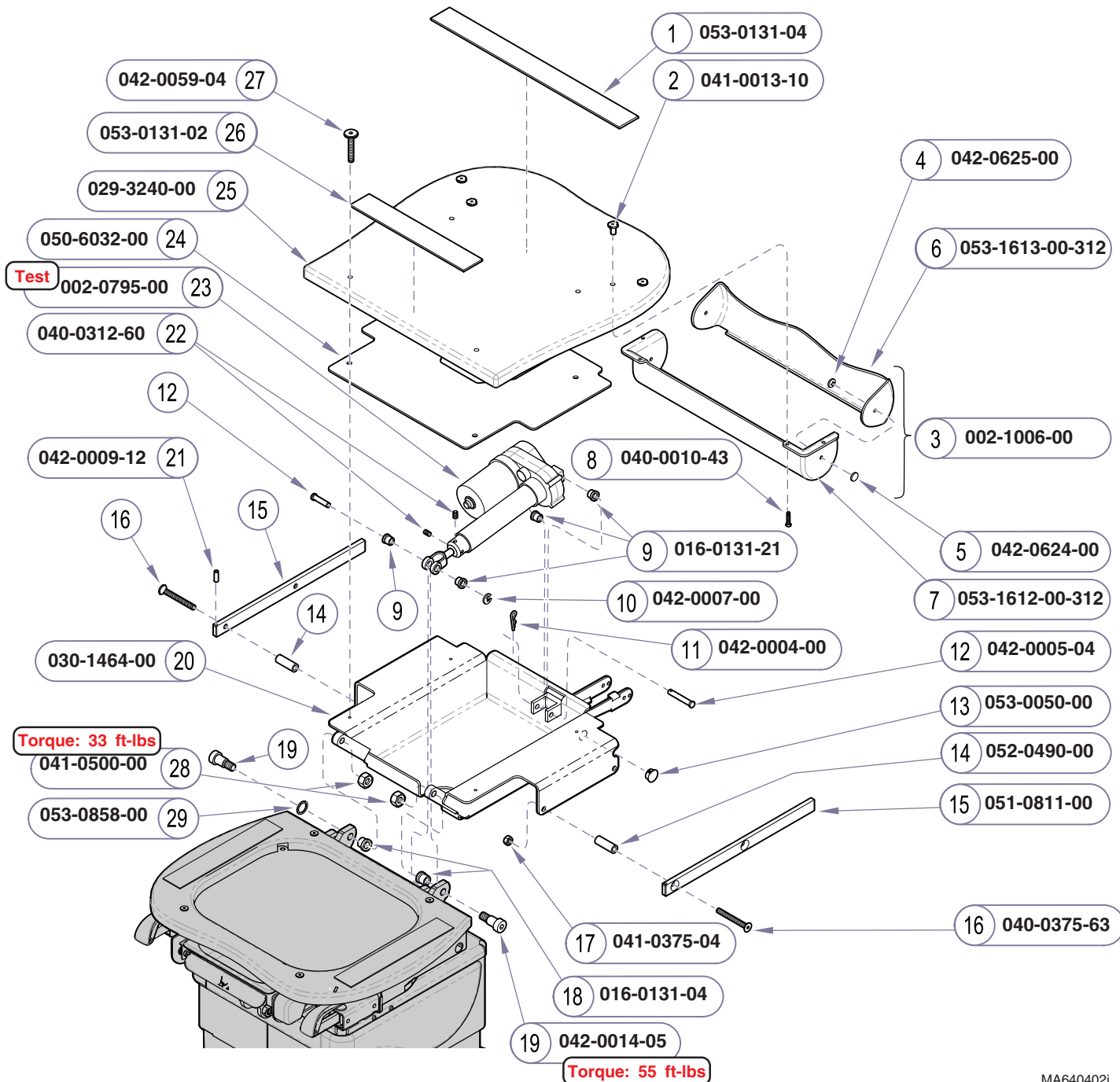

NOTE
 Actuator kit includes the choke & a grounding harness (015-0737-22). The grounding harness is required on early models only.

Item	Description	Qty.
1	Velcro Hook (2" x 20")	1
2	Wood Insert T-Nut	4
3	Paper Roll Holder Kit (includes items 4 thru 8)	1
4	• Ratchet Rivet	4
5	• Cap	2
6	• Paper Roll Holder Lid	1
7	• Paper Roll Holder	1
8	• Screw (#10-24 x 1" Phillips)	4
9	Flange Bearing	4
10	E-ring	1
11	Hitch Pin Clip	1
12	Clevis Pin	1
13	Hole Plug	1
14	Spacer	4
15	Side Rail	2
16	Bolt (3/8-16 x 3" Flathead Socket)	4
17	Nut (3/8-16)	4
18	Flange Bearing	2
19	Shoulder Bolt (5/8" x 3/4")	2
20	Back Weldment	1
21	Groove Pin (3/16" x 1/2")	2
22	Set Screw	2
23	Back Actuator Kit (see NOTE)	1
24	Back Assembly Cover	1
25	Back Mounting Board (includes all T-Nuts & velcro)	1
26	Velcro Hook (2" x 12")	1
27	JC Bolt (1/4-20 x 1.575")	4
28	Jam Nut (1/2"-13)	2
29	Washer, nylon	1

MA640402i

Always Specify Model & Serial Number

Models:	630 (all)	75 (-020/-021)
Serial Numbers:	V185141 thru Present	V185141 thru Present

Back Section:
 Midmark Models

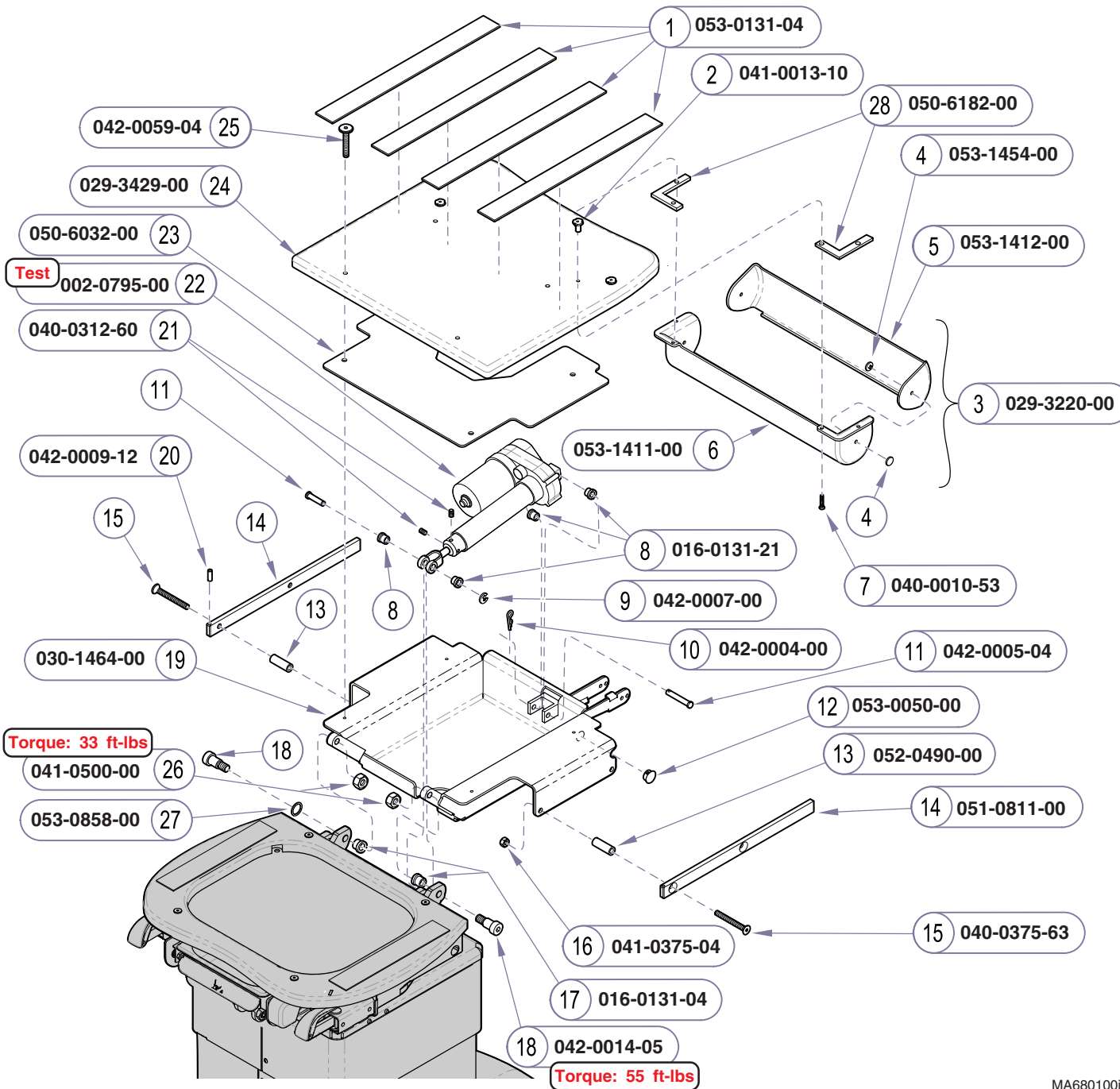

NOTE
 Actuator kit includes the choke & a grounding harness (015-0737-22). The grounding harness is required on early models only.

Item	Description	Qty.
1	Velcro Hook (2" x 20")	1
2	Wood Insert T-Nut	4
3	Paper Roll Holder Assembly (includes items 4 thru 6)	1
4	• Ratchet Rivet	4
5	• Paper Roll Holder Lid	1
6	• Paper Roll Holder	1
7	Screw (#10-24 x 1 1/4" Phillips Pan Head) ..	4
8	Flange Bearing	4
9	E-ring	1
10	Hitch Pin Clip	1
11	Clevis Pin	1
12	Hole Plug	1
13	Spacer	4
14	Side Rail	2
15	Bolt (3/8-16 x 3" Flathead Socket)	4
16	Nut (3/8-16)	4
17	Flange Bearing	2
18	Shoulder Bolt (5/8" x 3/4")	2
19	Back Weldment	1
20	Groove Pin (3/16" x 1/2")	2
21	Set Screw	2
22	Back Actuator Kit (see NOTE)	1
23	Back Assembly Cover	1
24	Back Mounting Board (includes all T-Nuts & velcro)	1
25	JC Bolt (1/4-20 x 1.575")	4
26	Jam Nut (1/2"-13)	2
27	Washer, nylon	1
28	Spacer	2

Always Specify Model & Serial Number

MA680100i

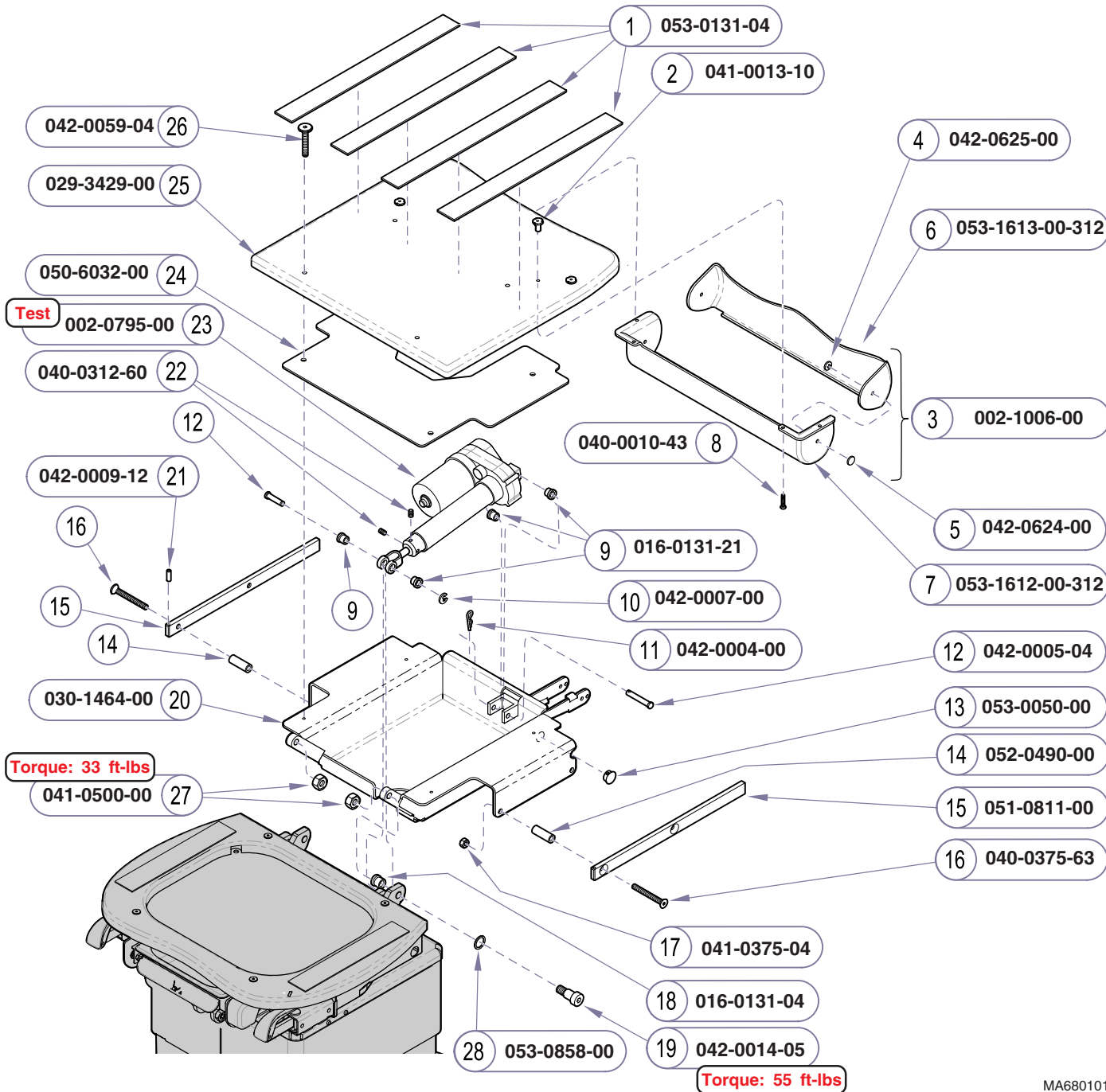

NOTE

Actuator kit includes the choke & a grounding harness (015-0737-22). The grounding harness is required on early models only.

Item	Description	Qty.
1	Velcro Hook (2" x 20")	1
2	Wood Insert T-Nut	4
3	Paper Roll Holder Kit (includes items 4 thru 8)	1
4	• Ratchet Rivet	4
5	• Cap	2
6	• Paper Roll Holder Lid	1
7	• Paper Roll Holder	1
8	• Screw (#10-24 x 1" Phillips)	4
9	Flange Bearing	4
10	E-ring	1
11	Hitch Pin Clip	1
12	Clevis Pin	1
13	Hole Plug	1
14	Spacer	4
15	Side Rail	2
16	Bolt (3/8-16 x 3" Flathead Socket)	4
17	Nut (3/8-16)	4
18	Flange Bearing	2
19	Shoulder Bolt (5/8" x 3/4")	2
20	Back Weldment	1
21	Groove Pin (3/16" x 1/2")	2
22	Set Screw	2
23	Back Actuator Kit (see NOTE)	1
24	Back Assembly Cover	1
25	Back Mounting Board (includes all T-Nuts & velcro)	1
26	JC Bolt (1/4-20 x 1.575")	4
27	Jam Nut (1/2"-13)	2
28	Washer, nylon	1

Always Specify Model & Serial Number

MA680101i

Models:	230 (all)	75 (-019)
Serial Numbers:	V185141 thru Present	V185141 thru Present

Back Section:
Ritter Models

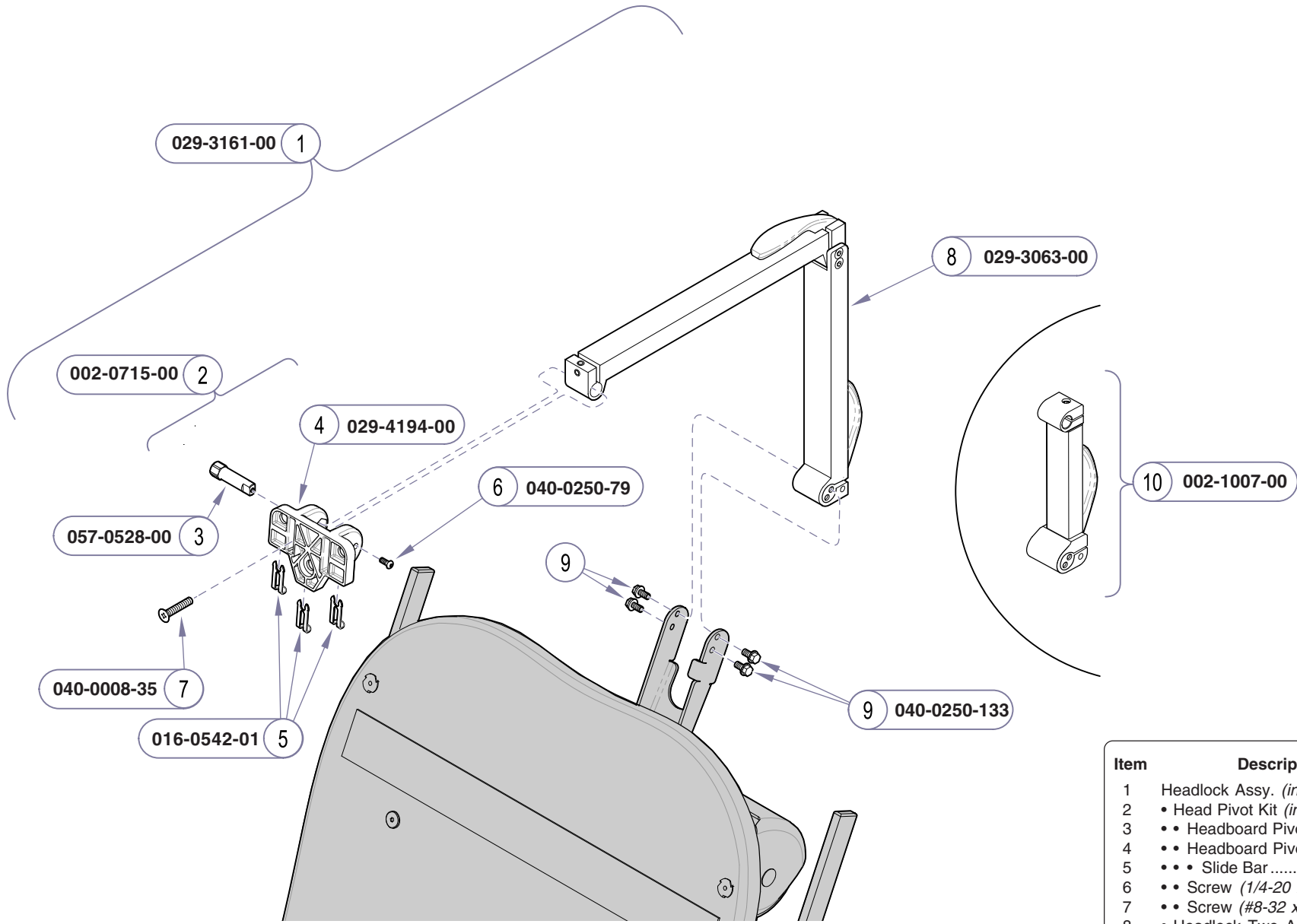

Item	Description	Qty.
1	Headlock Assy. (includes items 2 thru 8) ..	1
2	• Head Pivot Kit (incl. items 3 thru 7)	
3	•• Headboard Pivot Pin	1
4	•• Headboard Pivot Mount (incl. item 5)....	1
5	••• Slide Bar	3
6	•• Screw (1/4-20 x 5/8).....	1
7	•• Screw (#8-32 x 7/8 Flat Head).....	4
8	• Headlock Two Arm Assembly	1
9	Screw (1/4-20 x 1/2 Hex Head).....	1
10	Single Arm Headlock Kit (includes item 10 <u>only</u>).....	1

Always Specify Model & Serial Number

MA640601i

Headlock Assembly

Models: ALL
Serial Numbers:

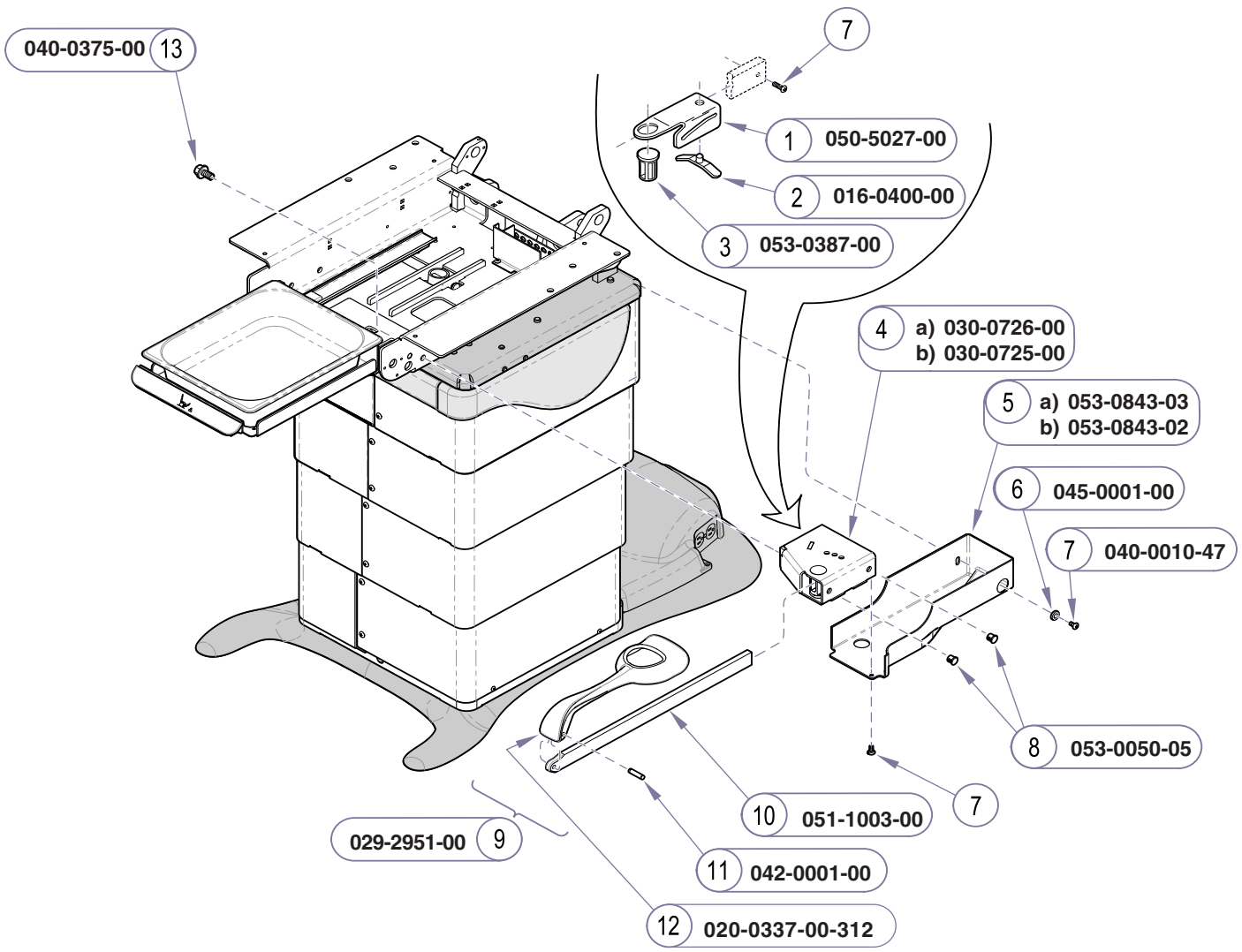

Item	Description	Qty.
1	Stirrup Guide Bracket	1
2	Stirrup Spring	2
3	Pivot Boss	2
4	Stirrup Mount:	
	a) Left Side (shown)	1
	b) Right Side (not shown)	1
5	Stirrup Housing:	
	a) Left Side (shown)	1
	b) Right Side (not shown)	1
6	Washer	2
7	Screw (10-24 x 3/8" Phillips pan Head)	6
8	Hole Plug	4
9	Stirrup Assembly (incl. items 10 thru 12) ...	2
10	• Stirrup Bar	1
11	• Roll Pin	1
12	• Stirrup	1
13	Bolt (3/8-16 x 3/4")	4

Always Specify Model & Serial Number

MA640300i

Models: ALL
Serial Numbers:

Stirrup Components

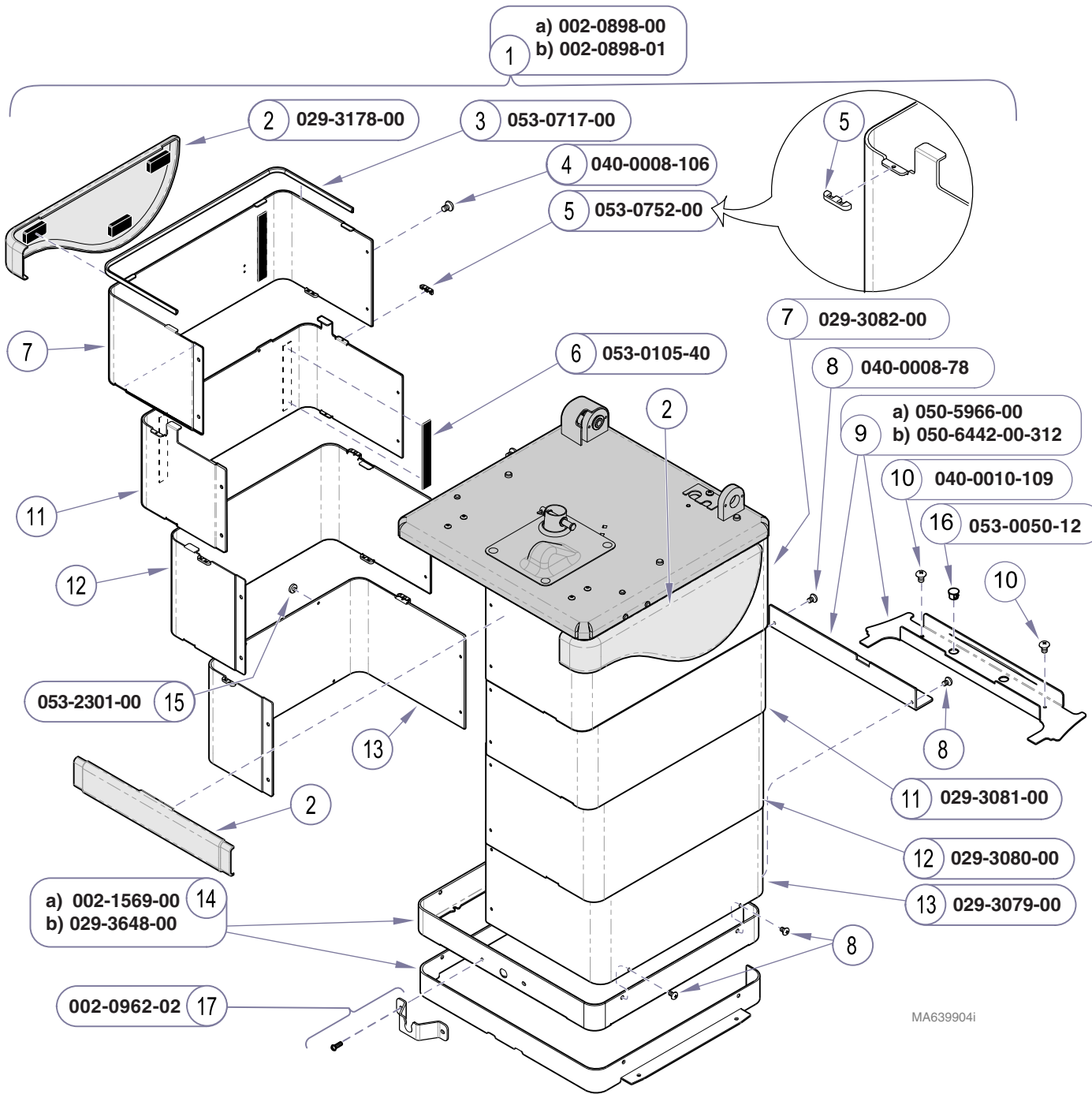

NOTE:
Shroud assemblies include all Snap-on-Guides (item 5) and nutserts.

Item	Description	Qty.
1	Midmark Shroud Set (incl. items 2 thru 16):	
	a) Standard base	1
	b) Rotational base	1
2	• Cladding Set (includes RH, LH, & front pieces)	1
3	• Outer Shroud Seal	2
4	• Screw (#8-32 x 1/4" truss head)	10
5	• Snap-on-guide	24
6	• Velcro Loop	4
7	• Outer Shroud Assembly	2
8	• Screw (#8-32 x 1/4" Pan Head)	10
9	• Wire Harness Cover:	
	a) Standard base	1
	b) Rotational base	1
10	• Screw	2
11	• Middle Outer Shroud Assembly	2
12	• Middle Inner Shroud Assembly	2
13	• Inner Shroud	2
14	• Shroud Spacer:	
	a) Standard base (incl. two #8-32 x 3/8" screws)	1
	b) Rotational base	1
15	• Bumper	2
16	• Hole Plug	2
17	Control Cord Bracket Kit (incl. bracket, two #8-32 x 3/8" screws, & two nuts)	1

Always Specify Model & Serial Number

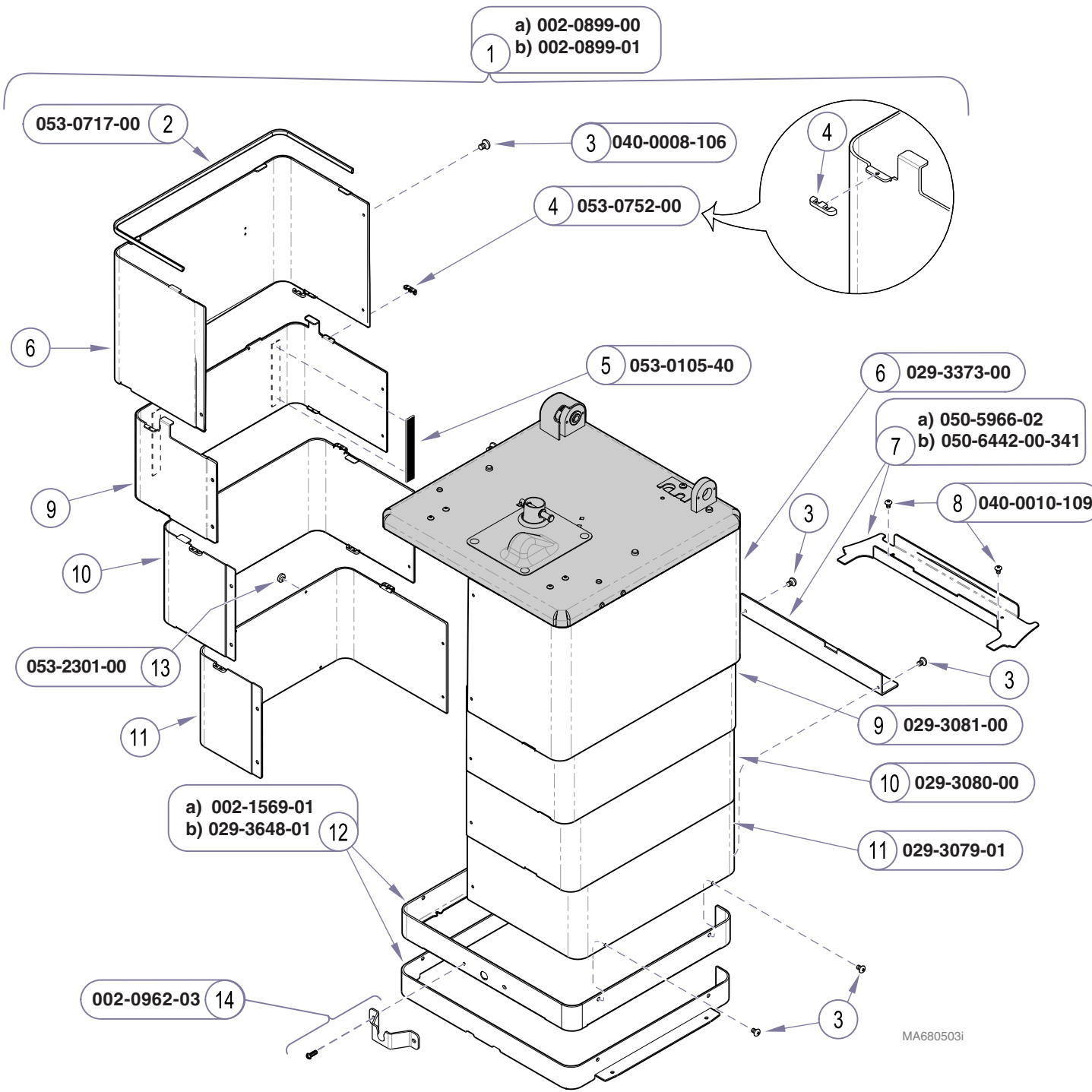

NOTE:
Shroud assemblies include all Snap-on-Guides (item 4) and nutserts.

Item	Description	Qty.
1	Ritter Shroud Set (incl. items 2 thru 13):	
	a) Standard base	1
	b) Rotational base	1
2	• Outer Shroud Seal	2
3	• Screw (#8-32 x 1/4" truss head)	22
4	• Snap-on-guide	24
5	• Velcro Loop	4
6	• Outer Shroud Assembly	2
7	• Wire Harness Cover:	
	a) Standard base	1
	b) Rotational base	1
8	• Screw	2
9	• Middle Outer Shroud Assembly	2
10	• Middle Inner Shroud Assembly	2
11	• Inner Shroud	2
12	• Shroud Spacer:	
	a) Standard base (incl. two #8-32 x 3/8" screws)	1
	b) Rotational base	1
13	• Bumper	2
14	Control Cord Bracket Kit (incl. bracket, two #8-32 x 3/8" screws, & two nuts)	1

Always Specify Model & Serial Number

Models:	230 (all)	75 (-019)
Serial Numbers:	All	All

Base Shrouds:
Ritter Models

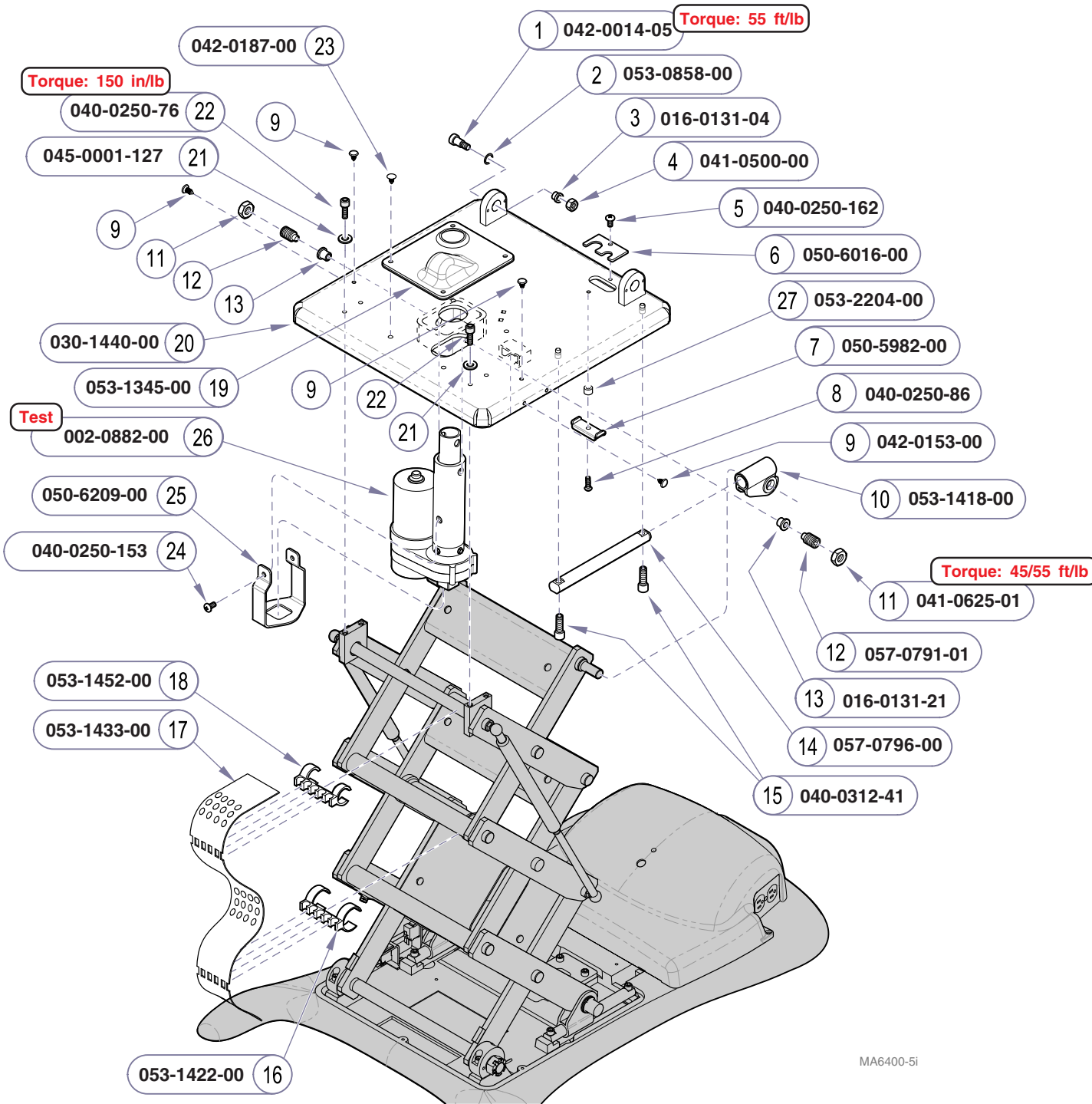

Item	Description	Qty.
1	Shoulder Bolt (5/8" x 3/4")	2
2	Washer, nylon	1
3	Flange Bearing	2
4	Jam Nut (1/2"-13)	2
5	Screw (1/4-20 x 1/2" Phillips)	1
6	Corrugated Tubing Bracket	1
7	Cable Restraint Clamp	1
8	Screw (1/4-20 x 3/4" Phillips Head)	1
9	Rivot Drive	6
10	Upper Glide	2
11	Jam Nut (5/8" x 11)	2
12	Pivot Screw	2
13	Brass Bushing	2
14	Guide Bar	2
15	Cap Screw (5/16-18 1" Socket Head)	4
16	Lower Wire Clamp	2
17	Wire Ribbon Guide	1
18	Upper Wire Clamp	2
19	Screw Tip Cover	1
20	Column Adaptor Weldment	1
21	Washer	4
22	Cap Screw (1/4-20 x 3/8" Socket Head) (Note: apply permanent thread adhesive) ..	4
23	Barbed Push Fastener	4
NOTE: Items 24 & 25 used on Ritter models only		
24	Screw (8-32 x 1/4")	2
25	Support Strap	1
26	Tilt Actuator (includes choke)	1
27	Spacer	1

Always Specify Model & Serial Number

Column Top Assembly

Models: **ALL**
Serial Numbers:

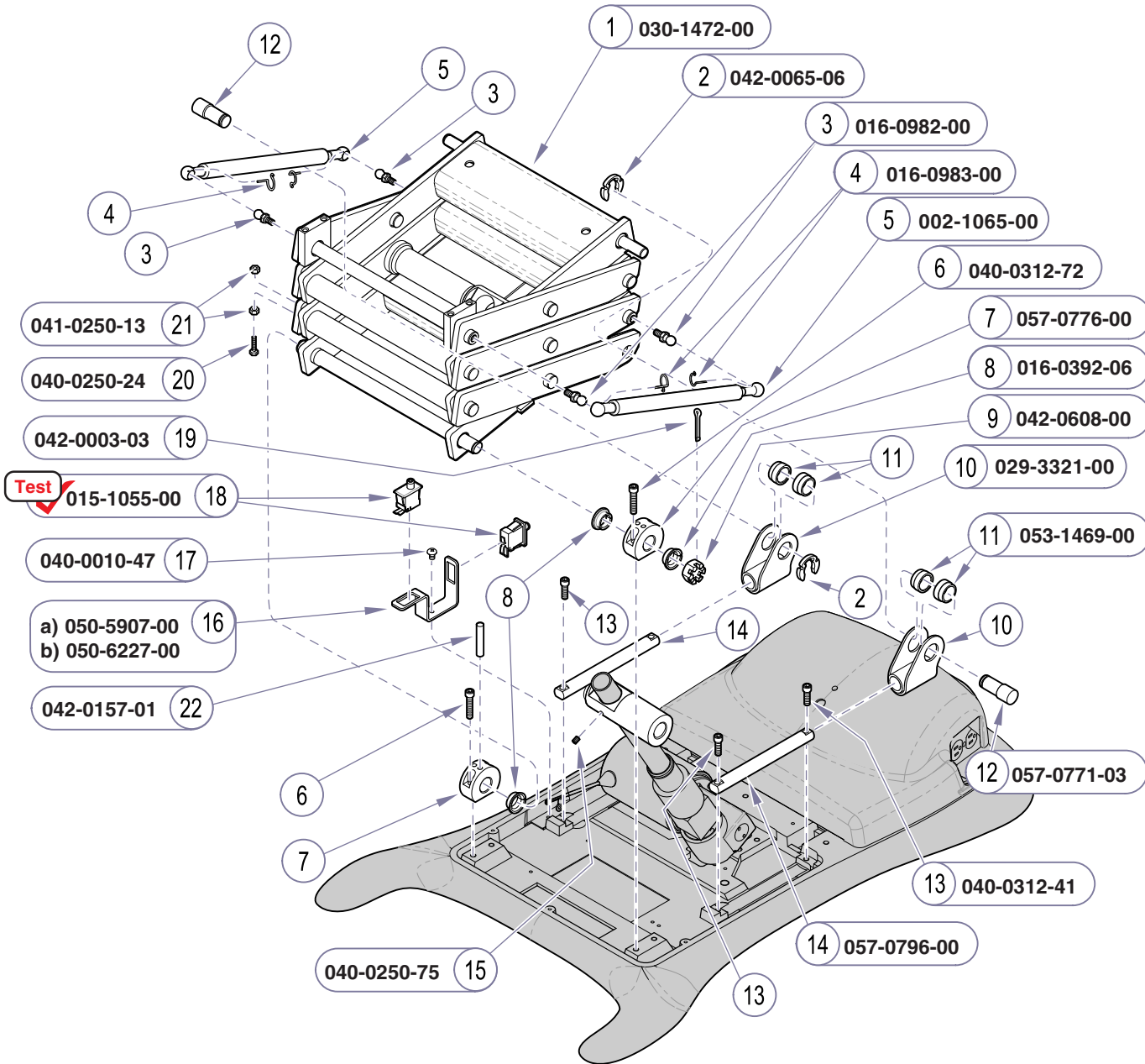

MA635402i

Item	Description	Qty.
1	Scissors Assembly	1
2	Clip Ring (3/4")	2
3	Gas Spring Ball Stud	4
4	Gas Spring Ball Clip	4
5	Gas Spring Kit (incl. two gas springs & four ball clips)	1
6	Bolt (5/16-18 x 1-1/2") socket head cap	4
7	Main Bearing Housing	2
8	Flange Bearing	3
9	Slotted Nut	1
10	Slide Weldment (incl. item 11)	2
11	• Bearing Insert	2
12	Guide Shaft	2
13	Bolt (5/16-18 x 1") socket head cap	4
14	Guide Bar	2
15	Set Screw	1
16	Limit Switch Bracket:	
	a) Midmark models	1
	b) Ritter models	1
17	Screw (10-32 x 3/8")	1
18	Limit Switch	2
19	Cotter Pin	1
20	Limit Switch Actuator Bolt (1/4-20 x 1")	1
21	Nut (1/4-20)	2
22	Stop Pin (Ritter models only)	2
23	Snap Ring	1

Always Specify Model & Serial Number

Models:	230 (all)	630 (all)	75 (-019 / -020 / -021)
Serial Numbers:	V1000 thru V109445	V1000 thru V109444	V1000 thru V109444

Scissor Components

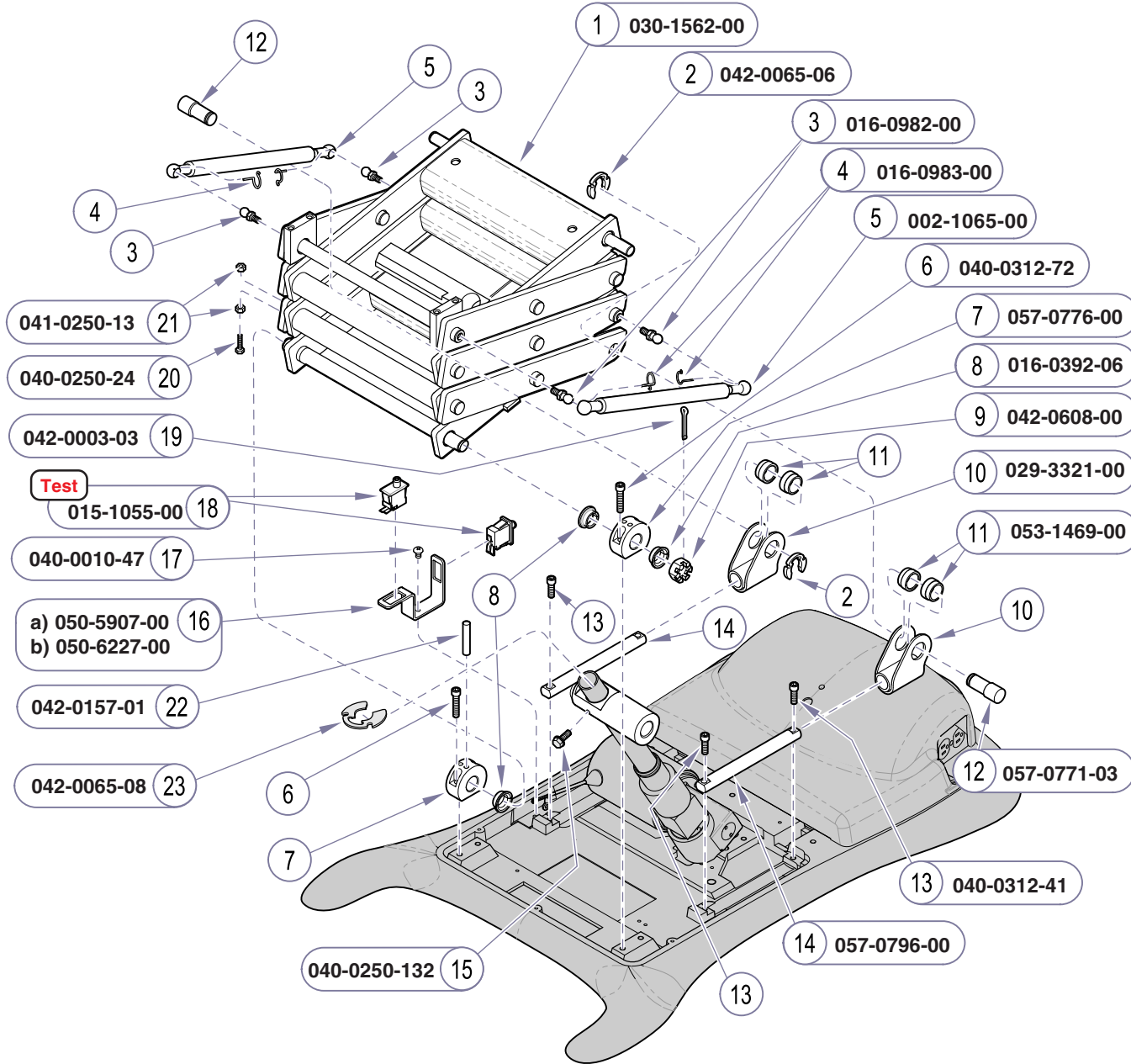

MA635404i

Item	Description	Qty.
1	Scissors Assembly	1
2	Clip Ring (3/4")	2
3	Gas Spring Ball Stud	4
4	Gas Spring Ball Clip	4
5	Gas Spring Kit (incl. two gas springs & four ball clips)	1
6	Bolt (5/16-18 x 1-1/2") socket head cap	4
7	Main Bearing Housing	2
8	Flange Bearing	3
9	Slotted Nut	1
10	Slide Weldment (incl. item 11)	2
11	• Bearing Insert	2
12	Guide Shaft	2
13	Bolt (5/16-18 x 1") socket head cap	4
14	Guide Bar	2
15	Hex Bolt (1/4-20 x 3/8")	1
16	Limit Switch Bracket: a) Midmark models	1
	b) Ritter models	1
17	Screw (10-32 x 3/8")	1
18	Limit Switch	2
19	Cotter Pin	1
20	Limit Switch Actuator Bolt (1/4-20 x 1")	1
21	Nut (1/4-20)	2
22	Stop Pin (Ritter models only)	2
23	Klip Ring	1

Always Specify Model & Serial Number

E-18.1

Scissor Components

Models:	230 (all)	630 (all)	75 (-019 / -020 / -021)
Serial Numbers:	V109946 thru present	V109445 thru present	V109445 thru present

* multiple pages due to model / serial # break

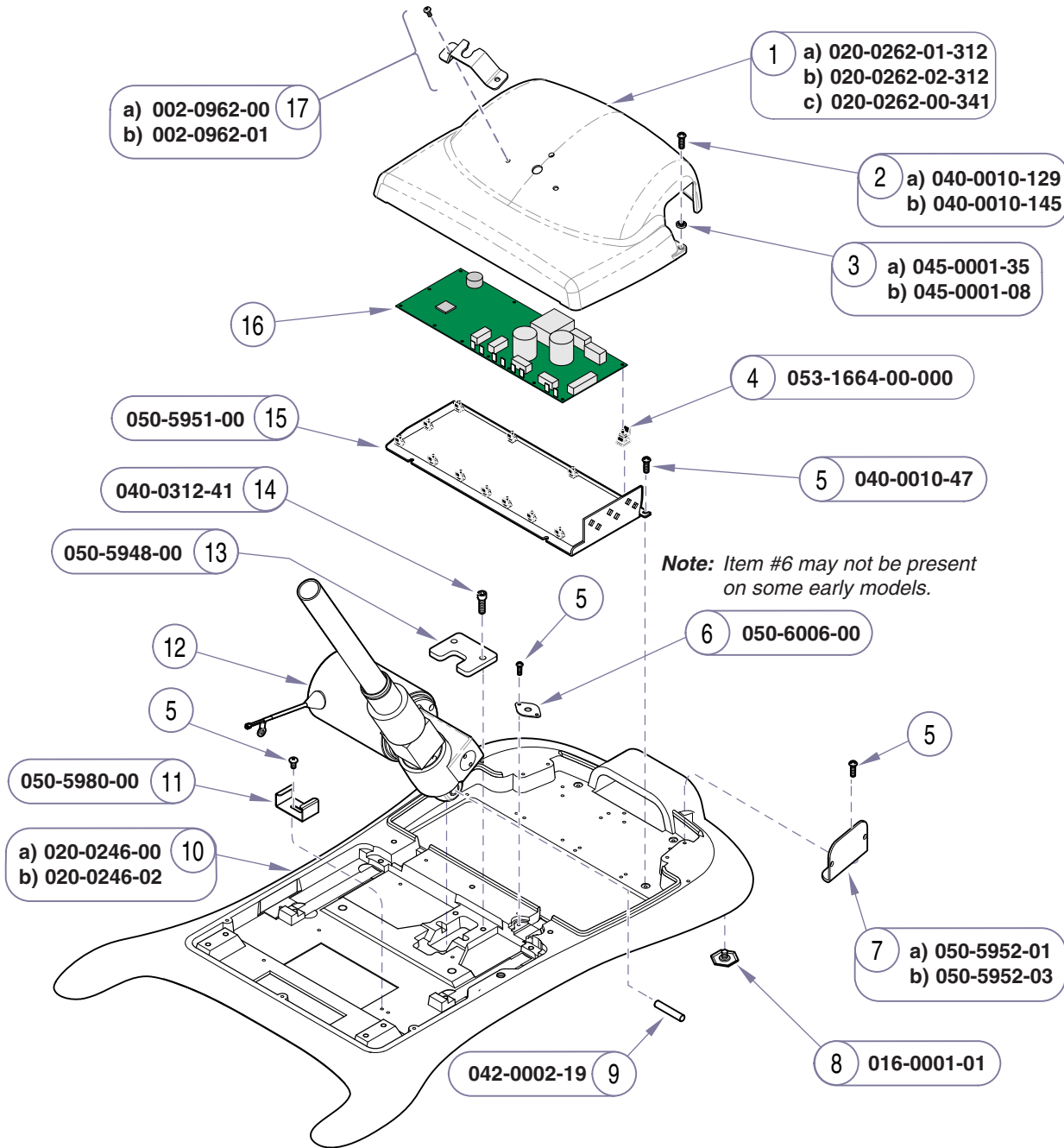

Item	Description	Qty.
1	PC Board Cover: a) Midmark models (w/o uph. heater) b) Midmark models (w/ uph. heater) c) Ritter models	1 1 1
2	Screw(10-24 x.37"): a) Midmark models b) Ritter models	2 2
3	Lock Washer: a) Midmark models b) Ritter models	3 3
4	PC Board Standoff	12
5	Screw (10-24 x 3/8" Phillips)	15
6	Grounding Plate	1
7	Cover Plate (models w/o receptacles): a) Midmark models b) Ritter models	2 2
8	Leveling Feet	4
9	Dowel Pin	1
10	Base Casting: a) Midmark models b) Ritter models	1 1
11	Harness Clip	1
12	Refer to: "Base Actuator"	Ref
13	Retaining Plate	1
14	Bolt (5/16-18 x 1" Socket Head)	2
15	Base Plate	1
16	Refer to: "Electrical Components"	Ref
17	Control Cord Bracket Kit (incl. screws): a) Midmark models b) Ritter models	1 1

Always Specify Model & Serial Number

MA639704i

Models:	230 (all)	630 (all)	75 (-019 / -020 / -021)
Serial Numbers:	V1000 thru V370643	V1000 thru V370643	V1000 thru V370643

Base Section Components

Refer To: **Page**
 Base Actuator E-24*
 Electrical Components E-23
 * multiple pages due to model / serial # break

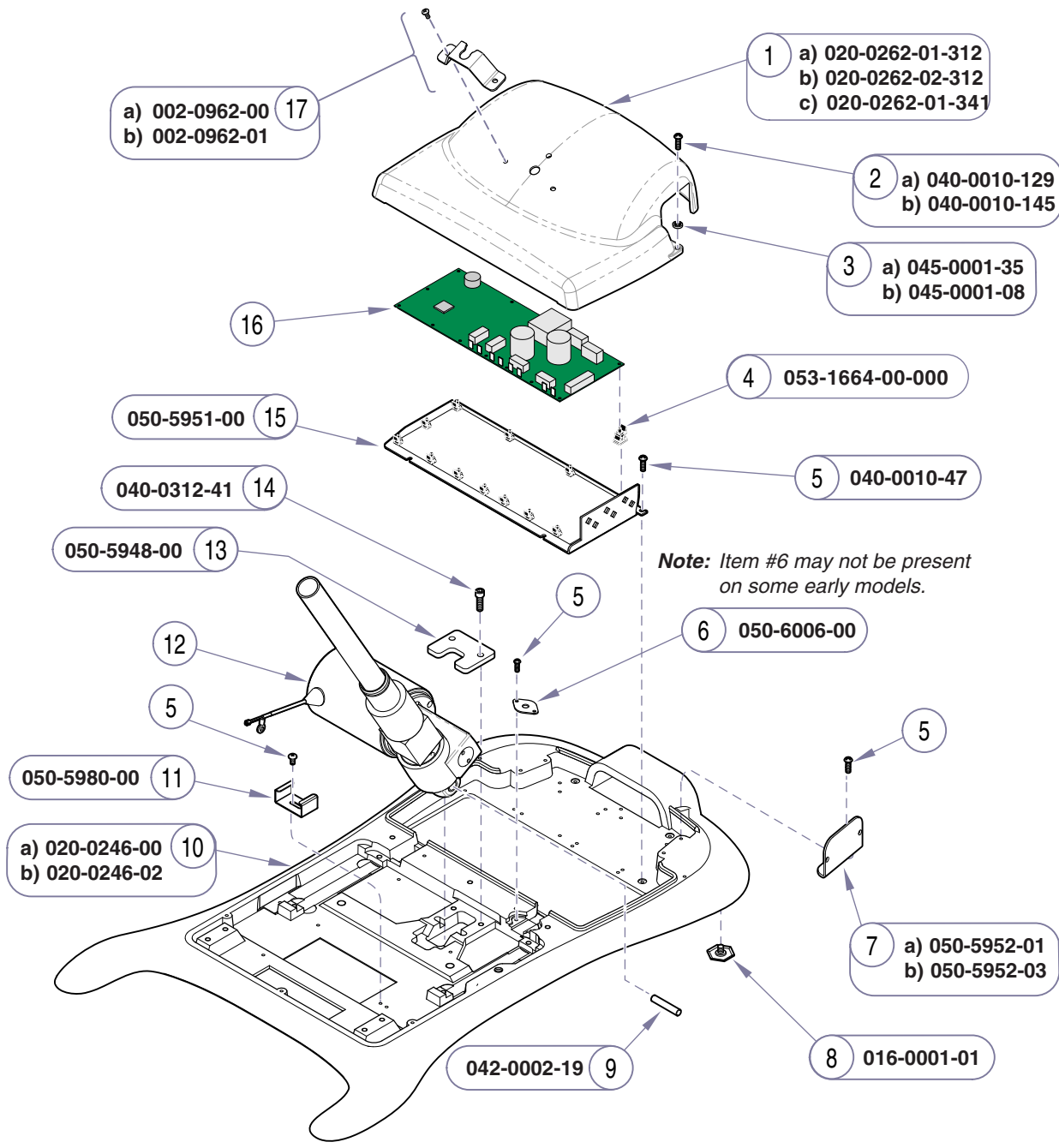

MA639704i

Item	Description	Qty.
1	PC Board Cover:	
	a) Midmark models (w/o uph. heater)	1
	b) Midmark models (w/ uph. heater)	1
	c) Ritter models	1
2	Screw(10-24 x.37"):	
	a) Midmark models	2
	b) Ritter models	2
3	Lock Washer:	
	a) Midmark models	3
	b) Ritter models	3
4	PC Board Standoff	12
5	Screw (10-24 x 3/8" Phillips)	15
6	Grounding Plate	1
7	Cover Plate (models w/o receptacles):	
	a) Midmark models	2
	b) Ritter models	2
8	Leveling Feet	4
9	Dowel Pin	1
10	Base Casting:	
	a) Midmark models	1
	b) Ritter models	1
11	Harness Clip	1
12	Refer to: "Base Actuator"	Ref
13	Retaining Plate	1
14	Bolt (5/16-18 x 1" Socket Head)	2
15	Base Plate	1
16	Refer to: "Electrical Components"	Ref
17	Control Cord Bracket Kit (incl. screws):	
	a) Midmark models	1
	b) Ritter models	1

Always Specify Model & Serial Number

This page intentionally left blank.

Models:
Serial Numbers:

Always Specify Model & Serial Number

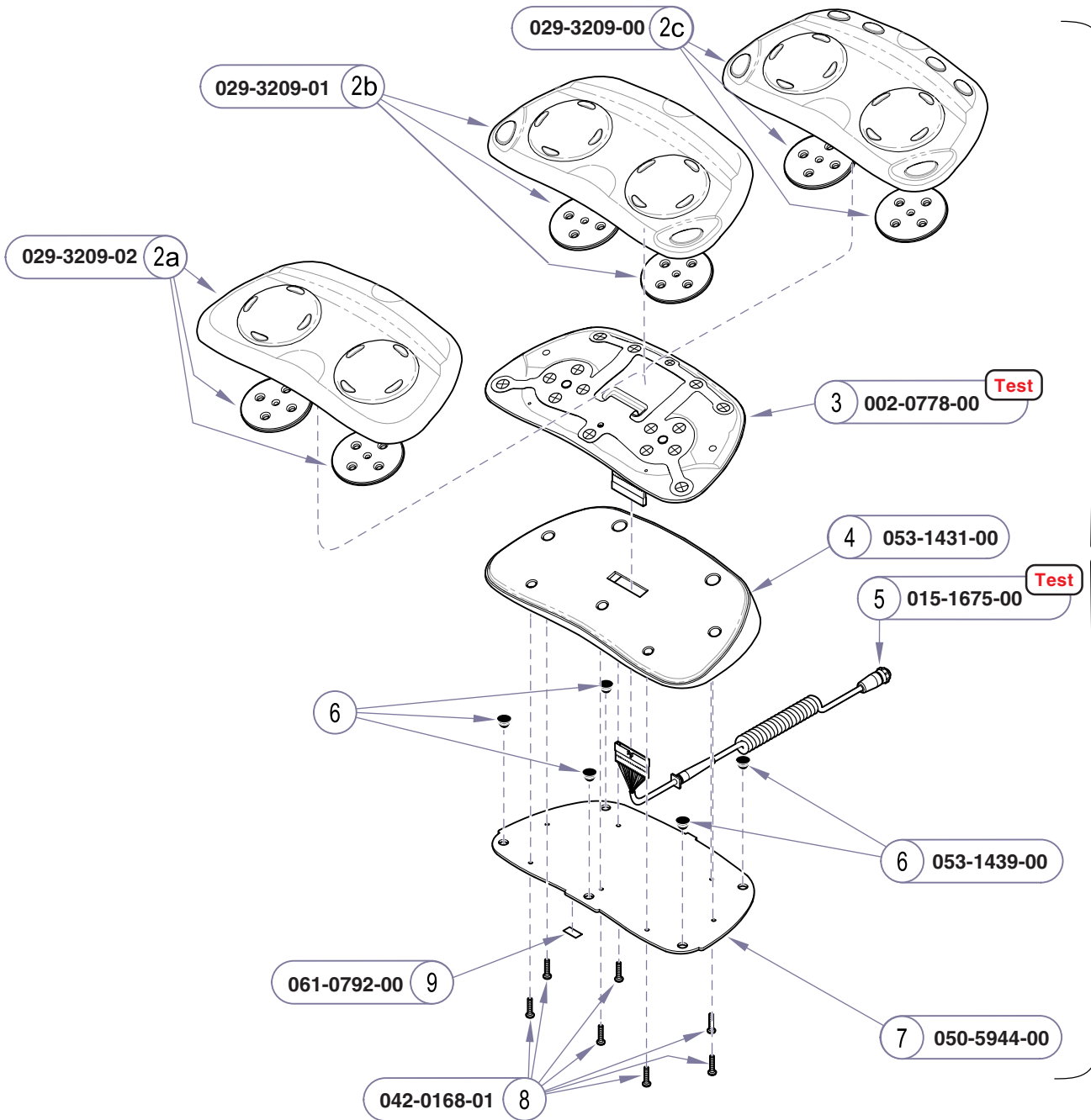

Refer To:	Page
Foot Control Test	B-6
Control Cord Continuity Test	B-7

- 1 a) 002-0760-02
- b) 002-0760-01
- c) 002-0760-00

Attention: Verify foot control style (Disc / Linear) when ordering parts.

Item	Description	Qty.
1	Foot Control Assy. (incl. items 2 thru 9):	
a)	Basic (230 / 75-019)	1
b)	Non-Programmable (630 / 75-020)	1
c)	Programmable (630 / 75-021)	1
2	• Keypad Assembly:	
a)	Basic (230 / 75-019)	1
b)	Non-Programmable (630 / 75-020)	1
c)	Programmable (630 / 75-021)	1
3	• Switch Membrane Kit	1
4	• Base	1
5	• Cord	1
6	• Stem Bumper	5
7	• Base Plate	1
8	• Screw (3.5-1.57 x 16)	7
9	• IPX1 Label	1

Always Specify Model & Serial Number

MA640901i

Foot Control
(Disc-Style)

Models: Serial Numbers:	230 (all) V1000 thru V370643	630 (all) V1000 thru V370643	75 (-019 / -020 / -021) V1000 thru V370643
----------------------------	---------------------------------	---------------------------------	---

Refer To:	Page
Foot Control Test	B-6
Control Cord Continuity Test	B-7

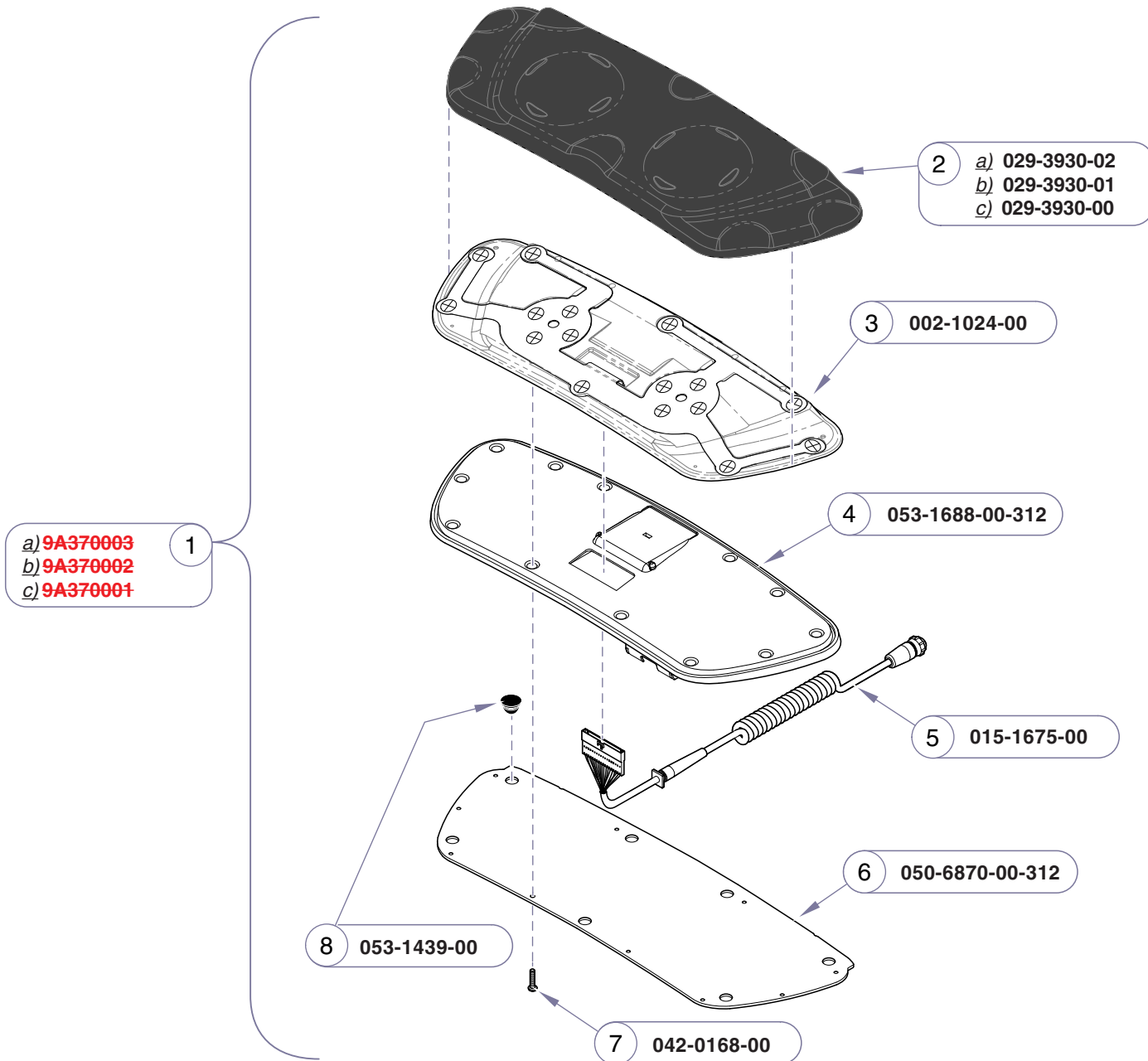

Attention: Verify foot control style (Disc / Linear) when ordering parts.

Item	Description	Qty.
1	Disc-Style Foot Control Assembly (includes items 2 thru 9):	
	a) Basic (230 / 75-019)	1
	b) Non-Programmable (630 / 75-020)	1
	c) Programmable (630 / 75-021)	1
2	• Keypad Assembly:	
	a) Basic (230 / 75-019)	1
	b) Non-Programmable (630 / 75-020)	1
	c) Programmable (630 / 75-021)	1
3	• Switch Membrane Kit	1
4	• Base	1
5	• Cord	1
6	• Base Plate	1
7	• Screw (3.5mm x 10mm)	10
8	• Stem Bumper	5
9	• IPX1 Label	1

Always Specify Model & Serial Number

Models:
Serial Numbers:

This accessory foot control is compatible with all Ritter / Midmark models.

Foot Control
(Disc-Style)

E-20.1

Refer To:	Page
Foot Control Test	B-6
Control Cord Continuity Test	B-7

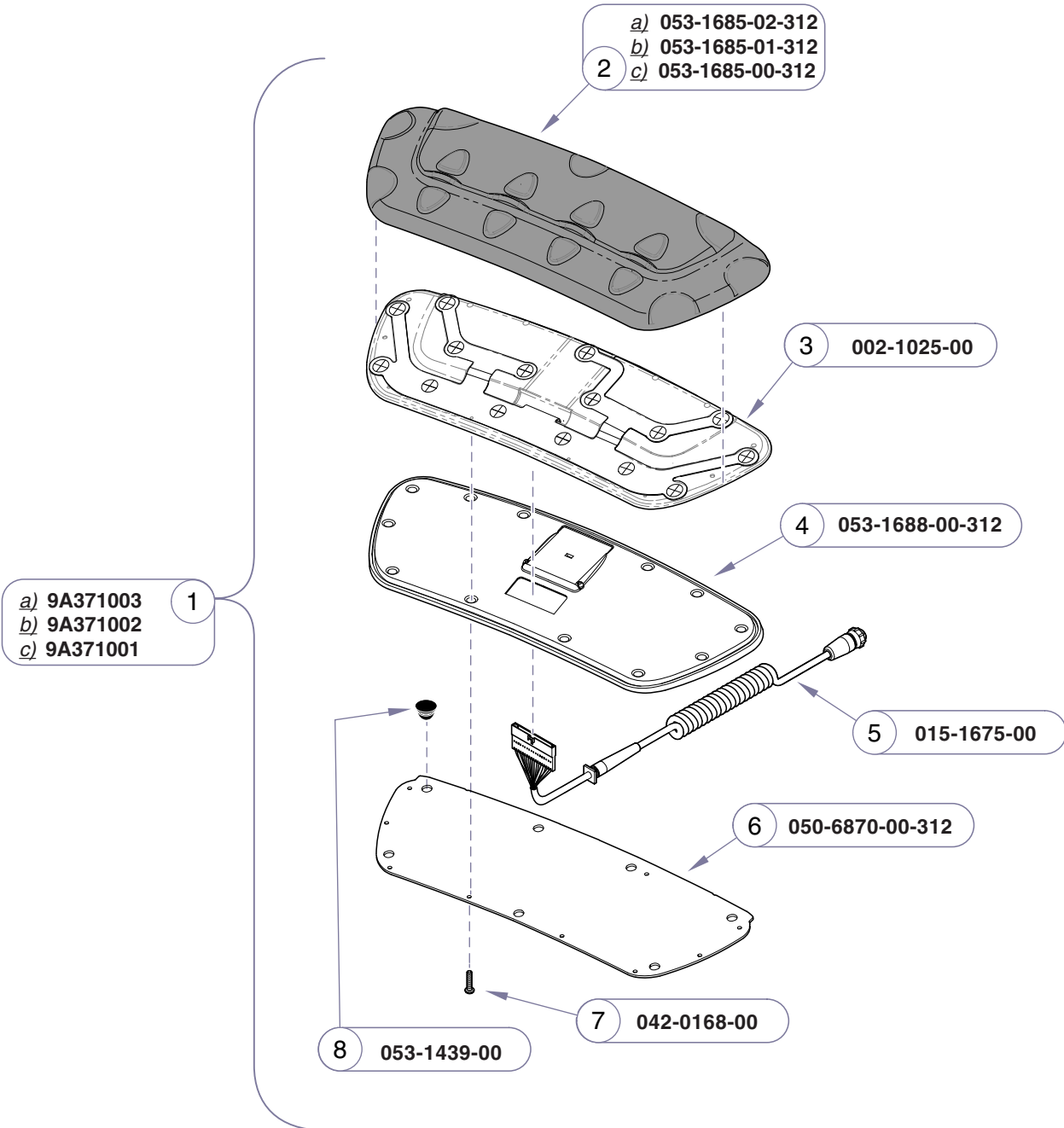

Attention: Verify foot control style (Disc / Linear) when ordering parts.

Item	Description	Qty.
1	Linear-Style Foot Control Assembly (includes items 2 thru 9):	
	a) Basic (230 / 75-019)	1
	b) Non-Programmable (630 / 75-020)	1
	c) Programmable (630 / 75-021)	1
2	• Keypad Assembly:	
	a) Basic (230 / 75-019)	1
	b) Non-Programmable (630 / 75-020)	1
	c) Programmable (630 / 75-021)	1
3	• Switch Membrane Kit	1
4	• Base	1
5	• Cord	1
6	• Base Plate	1
7	• Screw (3.5 mm x 10mm)	10
8	• Stem Bumper	7
9	• IPX1 Label (not shown)	1

Always Specify Model & Serial Number

NOTE: This foot control comes standard with the model / serial numbers listed below. It may also be used as a direct replacement for any other foot control (Ritter / Midmark).

Foot Control (Linear-Style)	Models: 630 (all) Serial Numbers: V370644 thru present
---------------------------------------	---

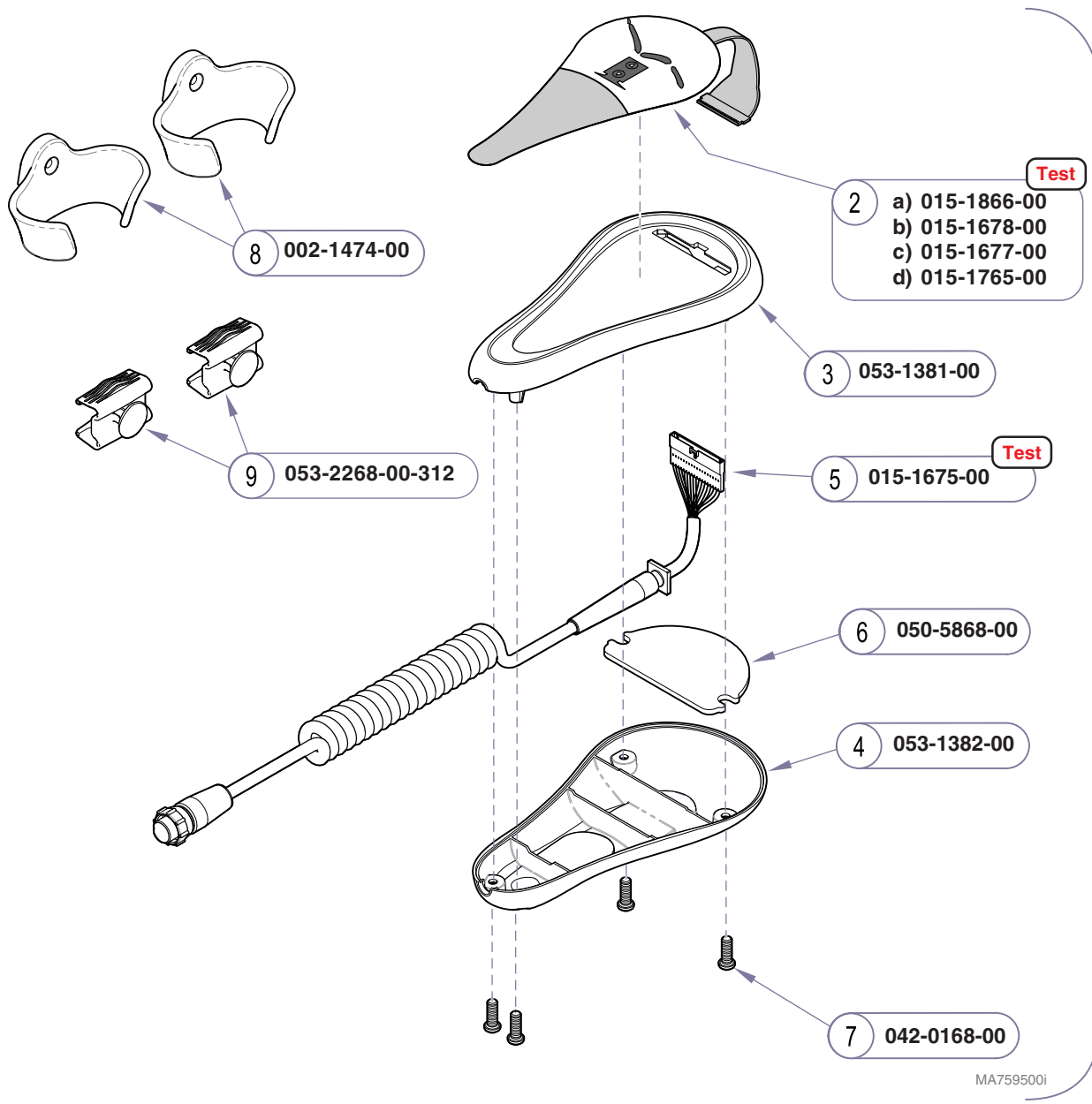

- 1 a) 002-0911-04
 b) 002-0911-02
 c) 002-0911-01
 d) 002-0911-05

- 2 a) 015-1866-00
 b) 015-1678-00
 c) 015-1677-00
 d) 015-1765-00

3 053-1381-00

- 5 015-1675-00

6 050-5868-00

4 053-1382-00

7 042-0168-00

8 002-1474-00

9 053-2268-00-312

Item	Description	Qty.
1	Hand Control Assy. (incl. items 2 thru 8)	
	a) Basic (230 / 75-019)	1
	b) Programmable (630 / 75-021)	1
	c) Non-Programmable (630 / 75-020)	1
	d) Programmable w/Htd Uph. (630)	1
2	• Touch Pad:	
	a) Basic (230 / 75-019)	1
	b) Programmable (630 / 75-021)	1
	c) Non-Programmable (630 / 75-020)	1
	d) Programmable w/Htd Uph. (630)	1
3	• Top Housing	1
4	• Bottom Housing	1
5	• Retractable Cord Assembly	1
6	• Hand Control Weight	1
7	• Screw (3,5 x 10)	4
8	• Kit, Hand Control Holsters (Includes Item 9)	1
9	• Siderail Hand Control Brackets	2

Always Specify Model & Serial Number

Models: ALL
Serial Numbers:

Hand Control

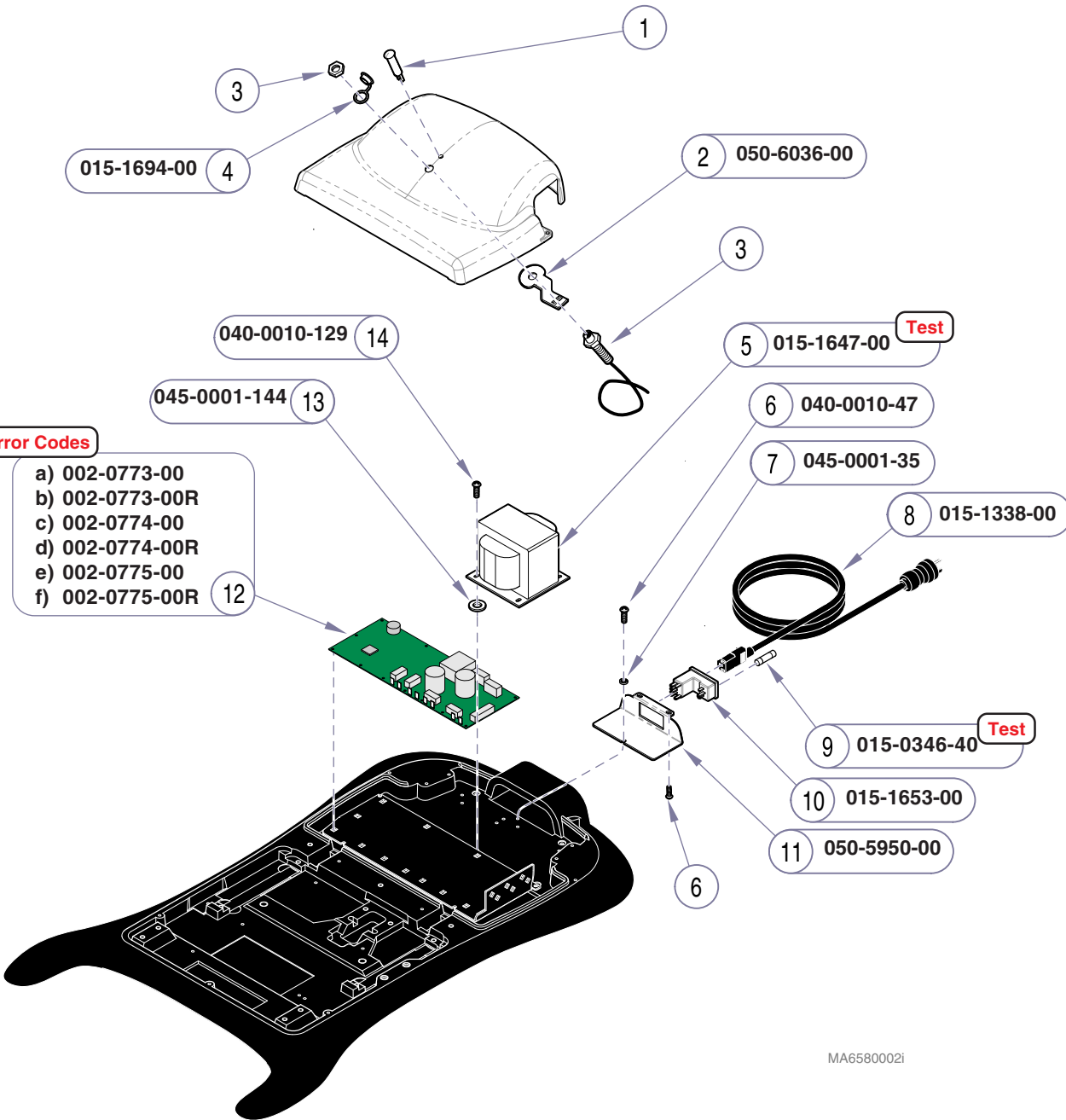

MA6580002i

MA6580002i

Refer To:	Page
Primary Fuse Test	B-2
Main System Transformer Test	B-30
Main PC Board - Error Codes	B-40
Section D - Wiring Diagrams	D-1

- Error Codes**
- a) 002-0773-00
 - b) 002-0773-00R
 - c) 002-0774-00
 - d) 002-0774-00R
 - e) 002-0775-00
 - f) 002-0775-00R

Item	Description	Qty.
1	Power Indicator Light w/wire harness (Refer to Section D)	Ref
NOTE: Items 2 thru 4 used on Midmark models only		
2	Cable Holder	1
3	Connection Port / Harness (includes nut) (Refer to Section D - Wiring Diagrams) ..	Ref
4	Dust Cap	1
5	Main System Transformer	1
6	Screw (10-24 x 3/8" Phillips)	3
7	Lockwasher	1
8	Power Cord (N. American, 120 VAC, 8 ft)	1
<i>Note: Export models require 9A152 International Cordsets.</i>		
9	Fuse (6.3 A, 250 V, Type "T", 5 x 20mm)	2
10	Power Inlet	1
11	Inlet Plate	1
12	PC Board:	
	a) Basic (230 / 75-019)	1
	b) Basic (230 [Refurbished])	1
	c) Non-Programmable (630 / 75-020)	1
	d) Non-Programmable (630 [Refurbished]) ..	1
	e) Programmable (630 / 75-021)	1
	f) Programmable (630 [Refurbished])	1
13	Rubber Washer	4
14	Screw (10-24 x 1/2" Phillips)	4

Always Specify Model & Serial Number

Electrical Components

Models: ALL
Serial Numbers:

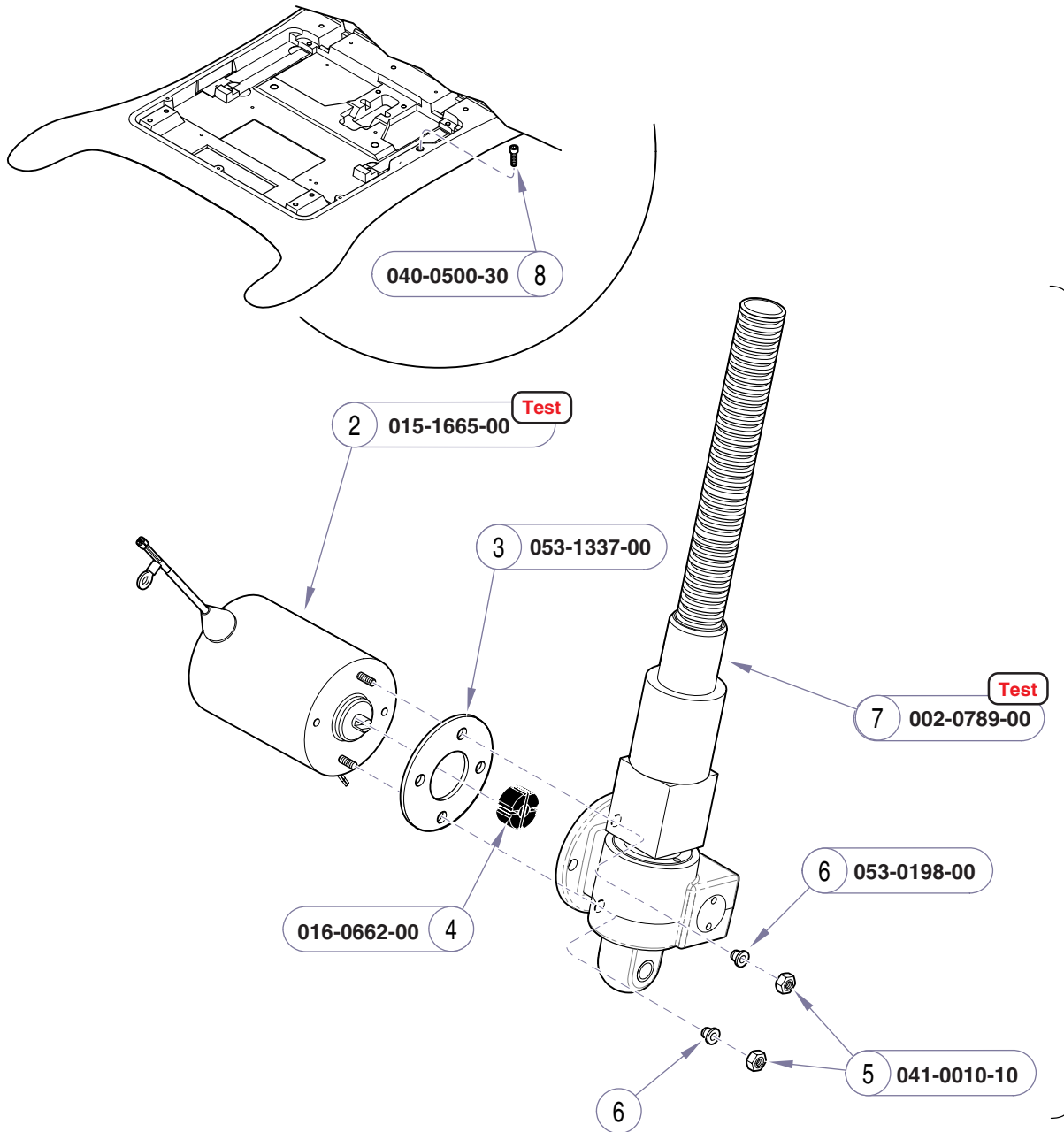

NOTE

The base actuator & ball screw assembly kits each include a grounding harness (015-0737-22). The grounding harness is required on early models only.

1 002-0789-01 **Test**

Item	Description	Qty.
1	Base Actuator Kit (includes items 2 thru 7) - see NOTE	1
2	• Motor	1
3	• Motor Isolator	1
4	• Coupler	1
5	• Nut	2
6	• Shoulder Washer	2
7	• Ball Screw Assembly Kit (includes item 8) - see NOTE	1
8	• • Stop Bolt	1

Always Specify Model & Serial Number

MA654501i

Models:	230 (all)	630 (all)	75 (-019 / -020 / -021)
Serial Numbers:	V1000 thru V109945	V1000 thru V109444	V1000 thru V109444

Base Actuator

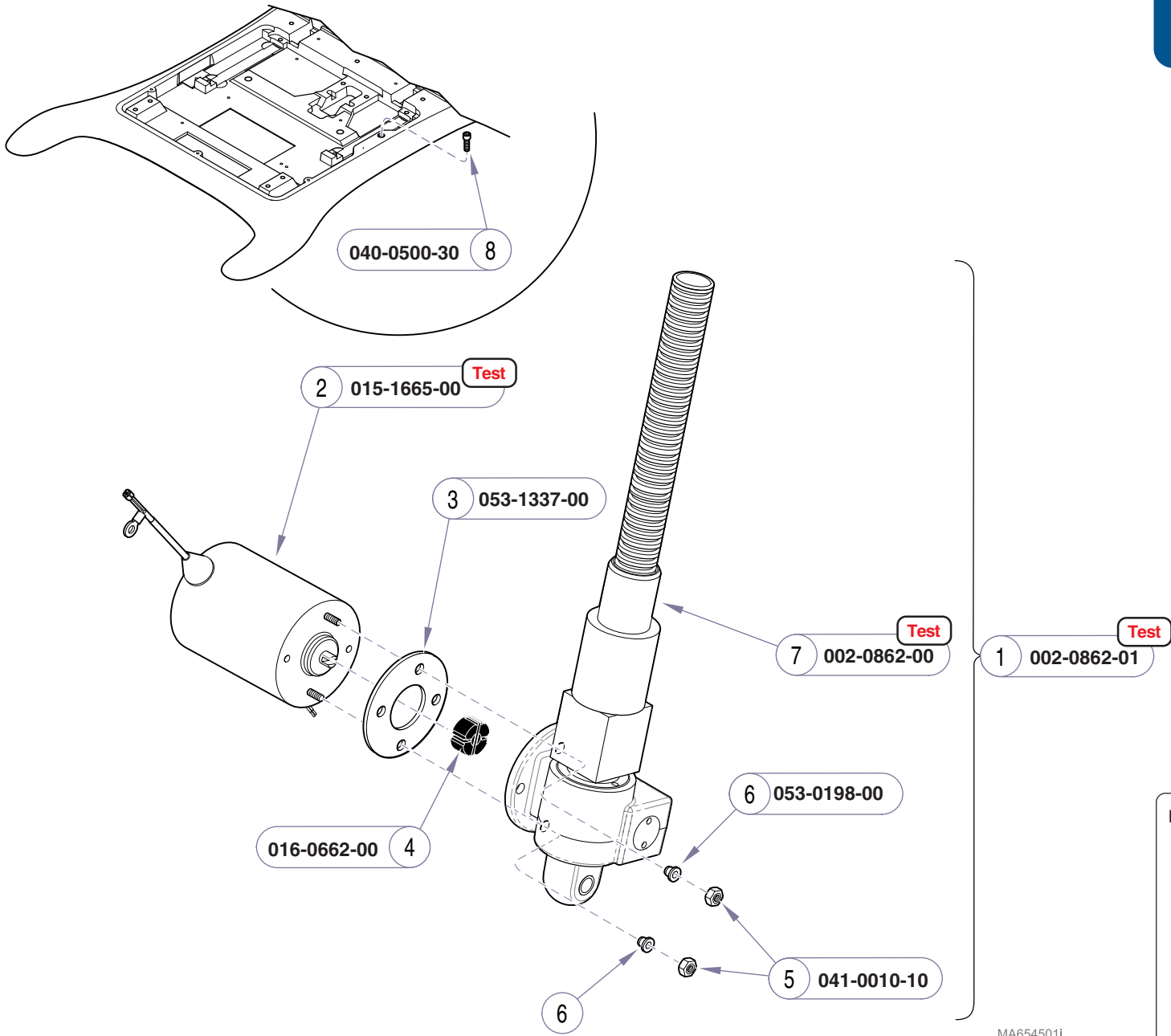

Item	Description	Qty.
1	Base Actuator Kit (includes items 2 thru 7)	1
2	• Motor	1
3	• Motor Isolator	1
4	• Coupler	1
5	• Nut	2
6	• Shoulder Washer	2
7	• Ball Screw Assembly Kit (includes item 8)	1
8	• • Stop Bolt	1

Always Specify Model & Serial Number

MA654501i

E-24.1

Base Actuator

Models:	230 (all)	630 (all)	75 (-019 / -020 / -021)
Serial Numbers:	V109946 thru V1399451	V109445 thru V1399451	V109445 thru V1399451

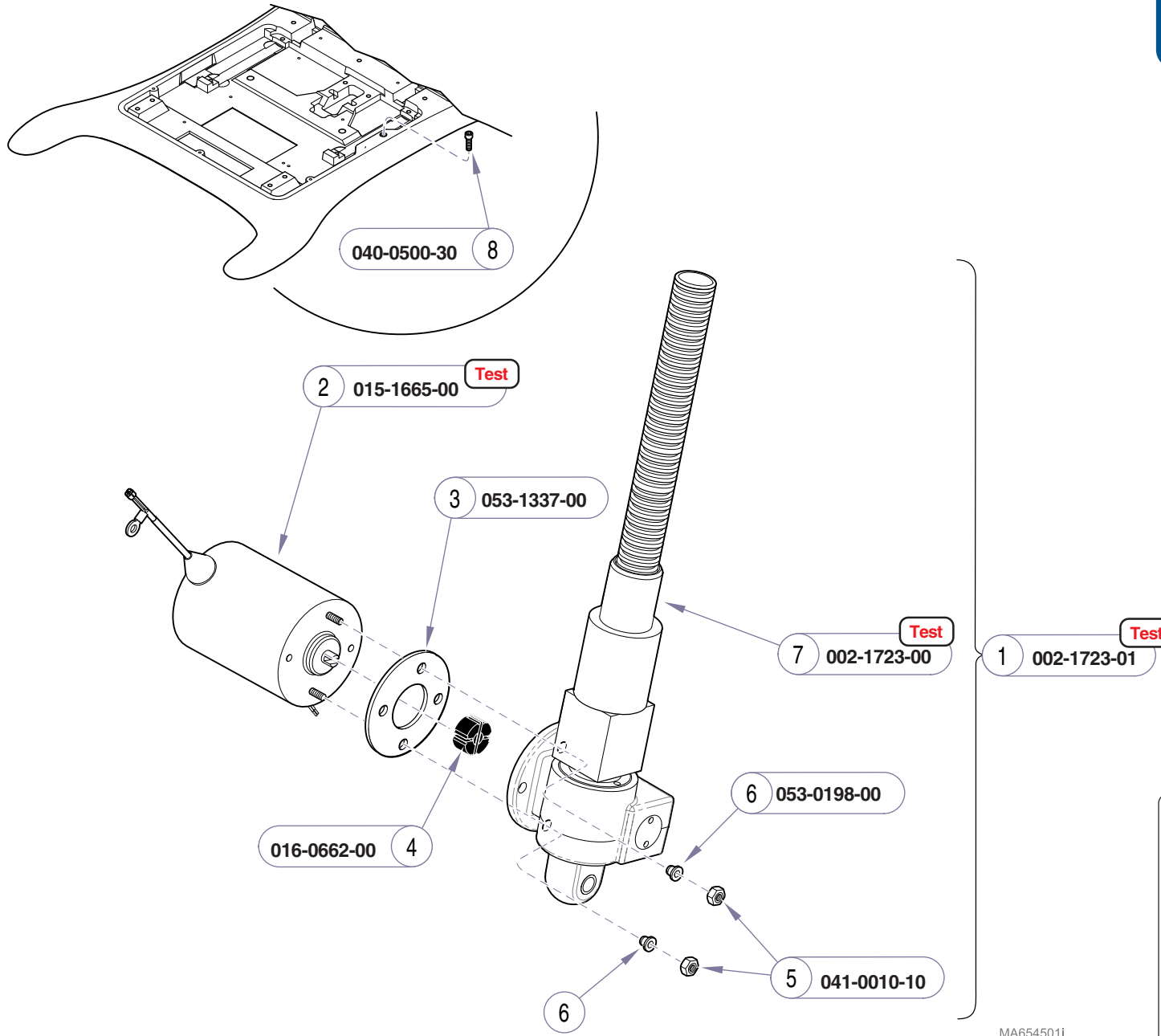

MA654501i

Item	Description	Qty.
1	Base Actuator Kit (includes items 2 thru 7)	1
2	• Motor	1
3	• Motor Isolator	1
4	• Coupler	1
5	• Nut	2
6	• Shoulder Washer	2
7	• Ball Screw Assembly Kit (includes item 8)	1
8	• • Stop Bolt	1

Always Specify Model & Serial Number

Models:	230 (all)	630 (all)	75 (-019 / -020 / -021)
Serial Numbers:	V1399452 thru present	V1399452 thru present	V1399452 thru present

Base Actuator

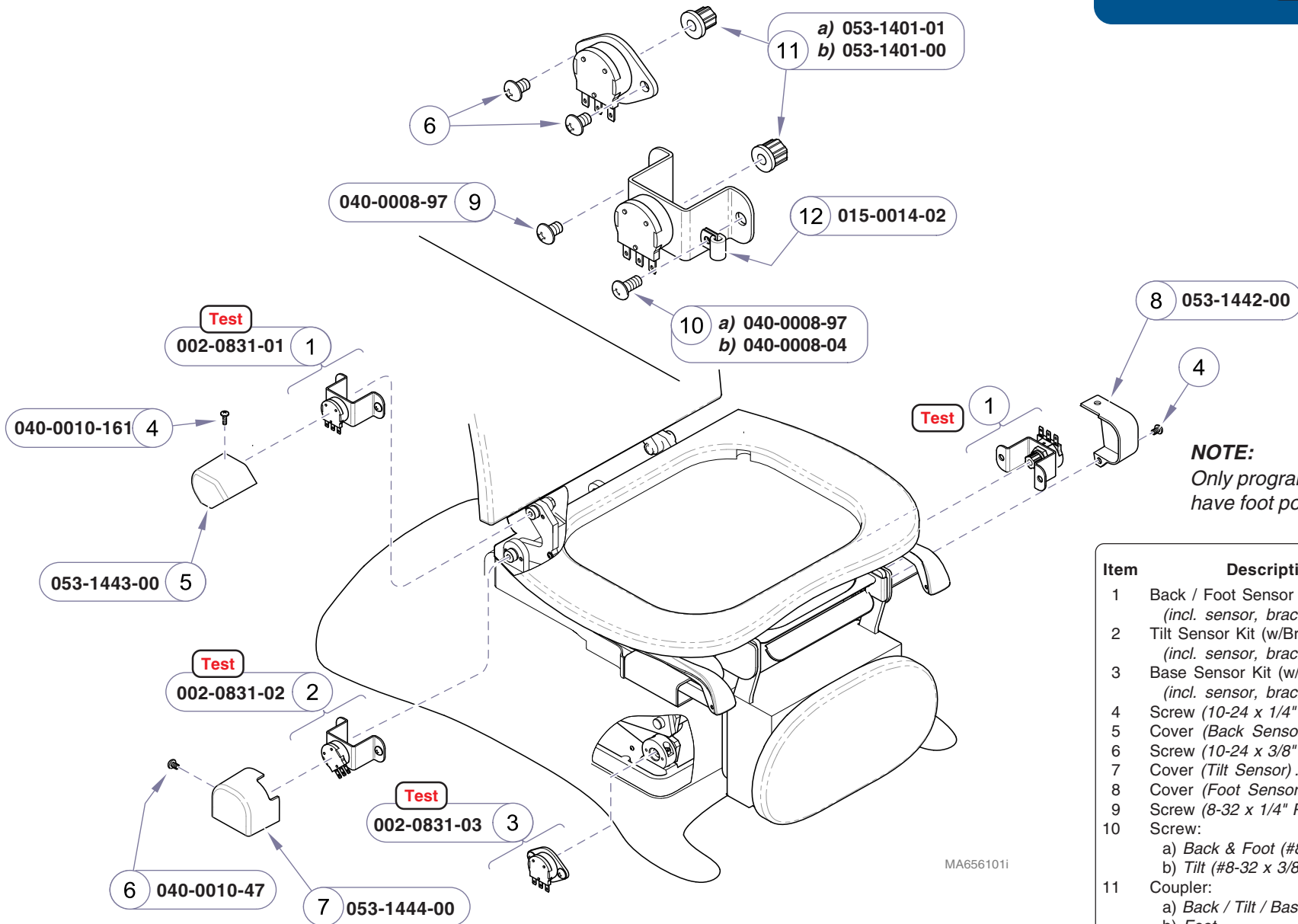

NOTE:
 Only programmable models
 have foot position sensor.

Item	Description	Qty.
1	Back / Foot Sensor Kit (w/Bracket) (incl. sensor, bracket, coupler)	2
2	Tilt Sensor Kit (w/Bracket) (incl. sensor, bracket, coupler)	1
3	Base Sensor Kit (w/Bracket) (incl. sensor, bracket, coupler)	1
4	Screw (10-24 x 1/4" Phillips Head)	4
5	Cover (Back Sensor)	1
6	Screw (10-24 x 3/8" Phillips Head)	3
7	Cover (Tilt Sensor)	1
8	Cover (Foot Sensor)	1
9	Screw (8-32 x 1/4" Phillips Head)	5
10	Screw: a) Back & Foot (#8-32 x 1/4")	3
	b) Tilt (#8-32 x 3/8")	1
11	Coupler: a) Back / Tilt / Base	3
	b) Foot	1
12	Cable Clamp (Tilt sensor only)	1

Always Specify Model & Serial Number

Models:	630 (all)	75 (-020/-021)
Serial Numbers:	V1000 thru V775313	All

Position Sensors

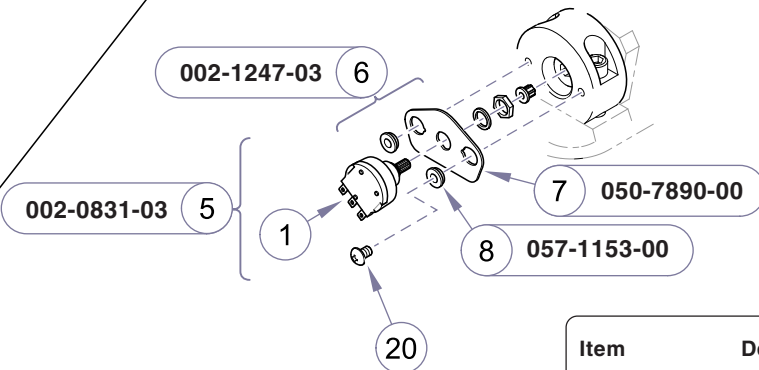
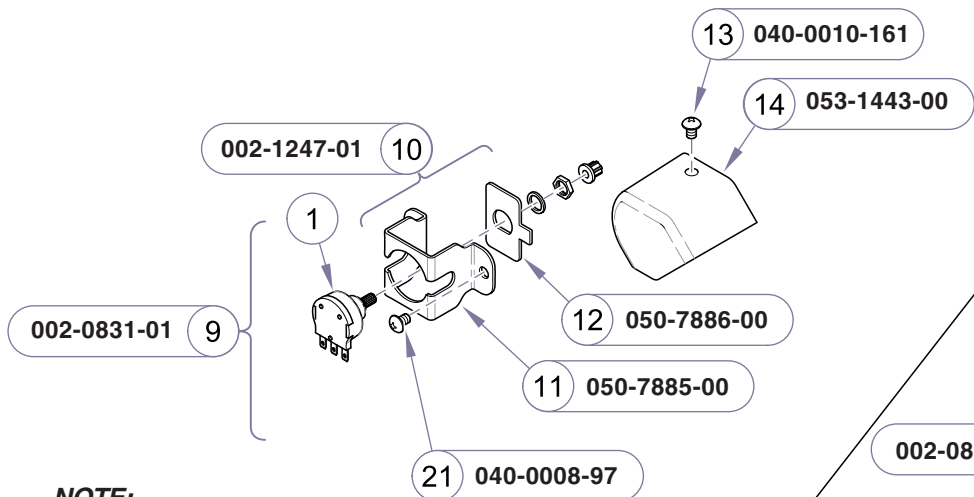

NOTE:
 Only programmable models
 have foot position sensor.

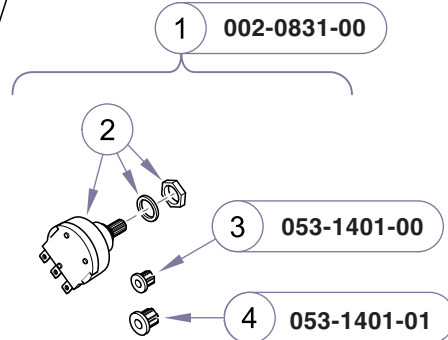
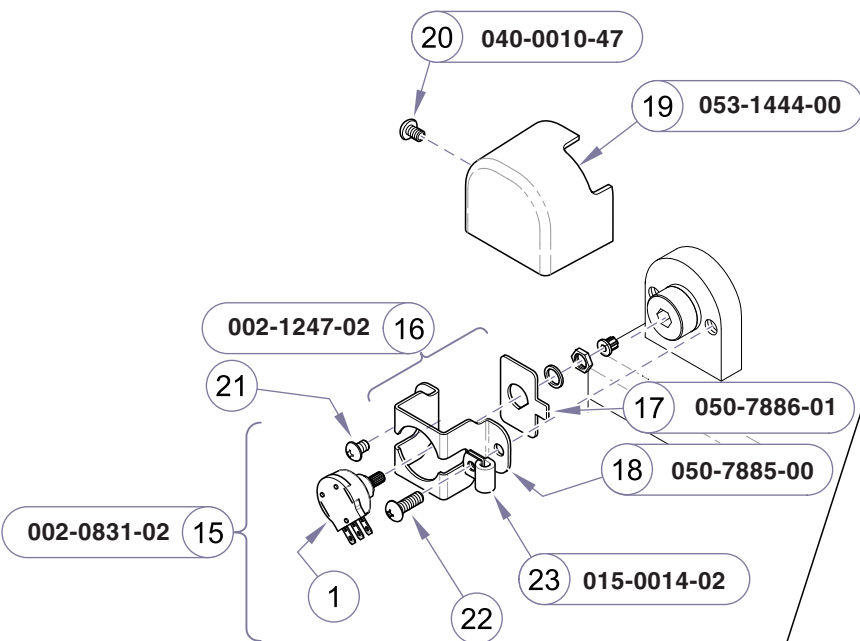

Item	Description	Qty.
1	Position Sensor <u>Only</u> Kit (includes items 2 thru 4)	4
2	• Position Sensor (incl. washer & nut)	1
3	• Coupler (small: for Foot)	1
4	• Coupler (large: for Base / Back / Tilt)	1
5	BASE Sensor Kit w/Bracket (includes items 1 & 6)	1
6	• Bracket Kit: BASE (incl. items 7 & 8)	1
7	• • Mounting Plate	1
8	• • Flange Bushing	2
9	BACK / FOOT Sensor Kit w/Bracket (includes items 1 & 10)	2
10	• Bracket Kit: BACK / FOOT (includes items 11 & 12)	2
11	• • Bracket	1
12	• • Mounting Plate	1
13	Screw (#10-24 x 1/4")	1
14	Cover (BACK Sensor)	1
15	TILT Sensor Kit w/Bracket (includes items 1 & 16)	1
16	• Bracket Kit: TILT (includes items 17 & 18)	1
17	• • Bracket	1
18	• • Mounting Plate	1
19	Cover (TILT Sensor)	1
20	Screw (#10-24 x 3/8")	3
21	Screw (#8-32 x 1/4")	5
22	Screw (#8-32 x 3/8")	1
23	Wire Clamp	1

MA8048i

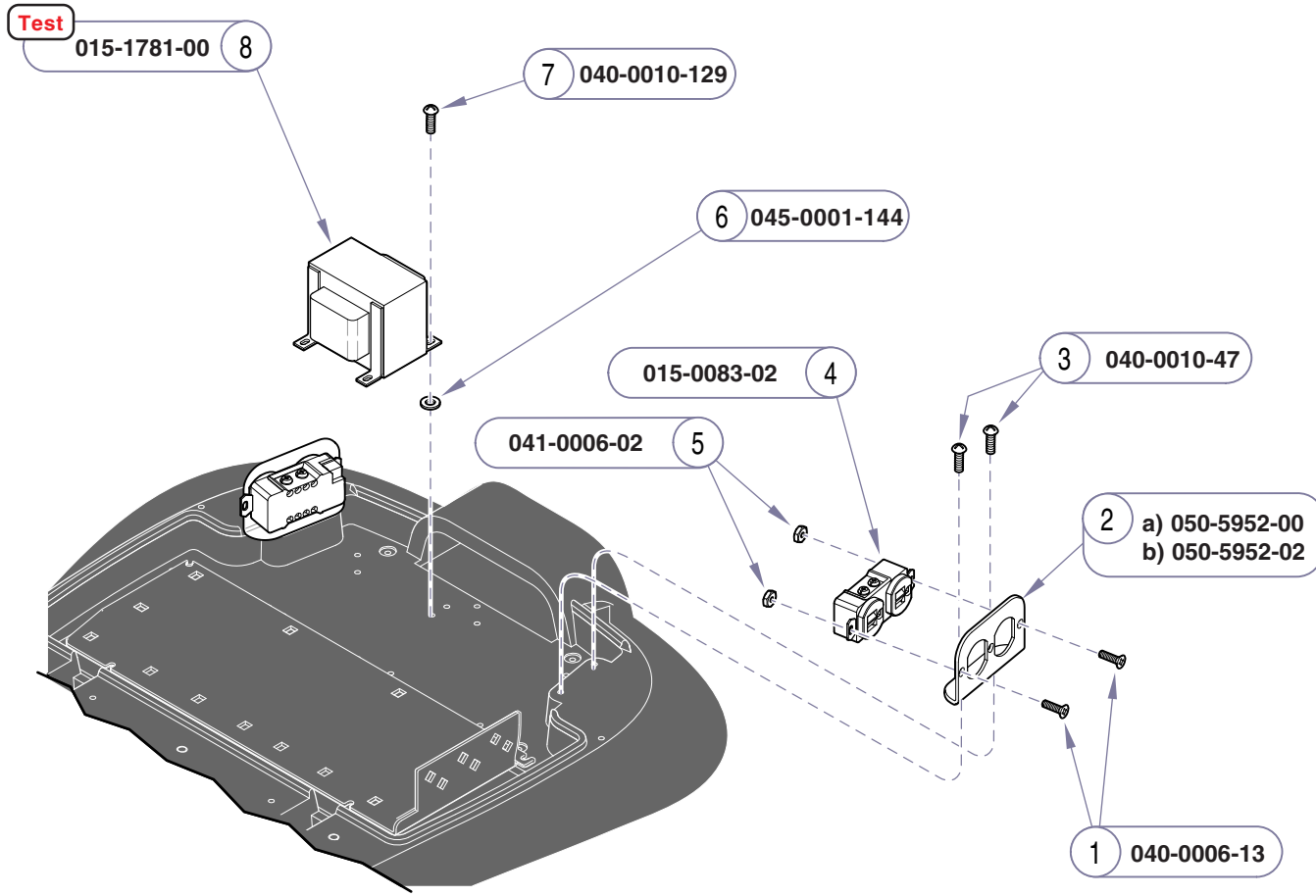

Item	Description	Qty.
1	Screw (6-32 x self-tap)	4
2	Receptacle Plate:	
	a) Midmark models	2
	b) Ritter models	2
3	Screw (10-24 x 3/8" pan head)	4
4	Duplex Receptacle	2
5	Nut (6-32 hex)	4
6	Rubber Washer	4
7	Screw (10-24 x 1/2" Phillips)	4
8	Isolation Transformer	1

Always Specify Model & Serial Number

MA658102i

Models:	230 (-002)	630 (-003/-004/-008/-009)	75 (-020/-021)
Serial Numbers:	All	All	All

Table Receptacles

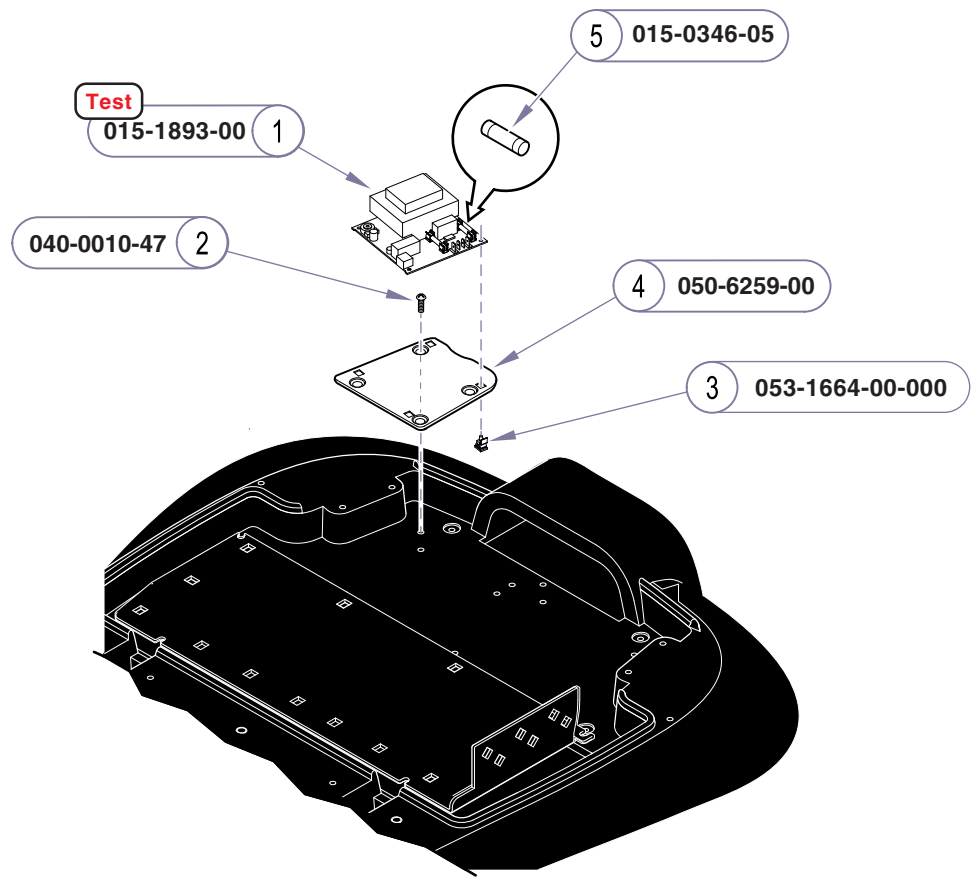

MA694700i

Item	Description	Qty.
1	Upholstery Heater PC Board [includes two fuses (item 5)]	1
2	Screw (#10-24 x 3/8")	4
3	Standoff	4
4	Mounting Plate	1
5	Fuse (3 ag, Slo-Blo, 0.5 A, 250V)	2
6	Wiring Harnesses - not shown (refer to: Section D - Wiring Diagrams) ..	Ref

Always Specify Model & Serial Number

Models: 630 (-007)
Serial Numbers: V2200 thru present

**Upholstery Heater
 PC Board**

Refer To: **Page**
 Electro-magnet **Test** B-53
 EMI Filter Board **Test** B-54

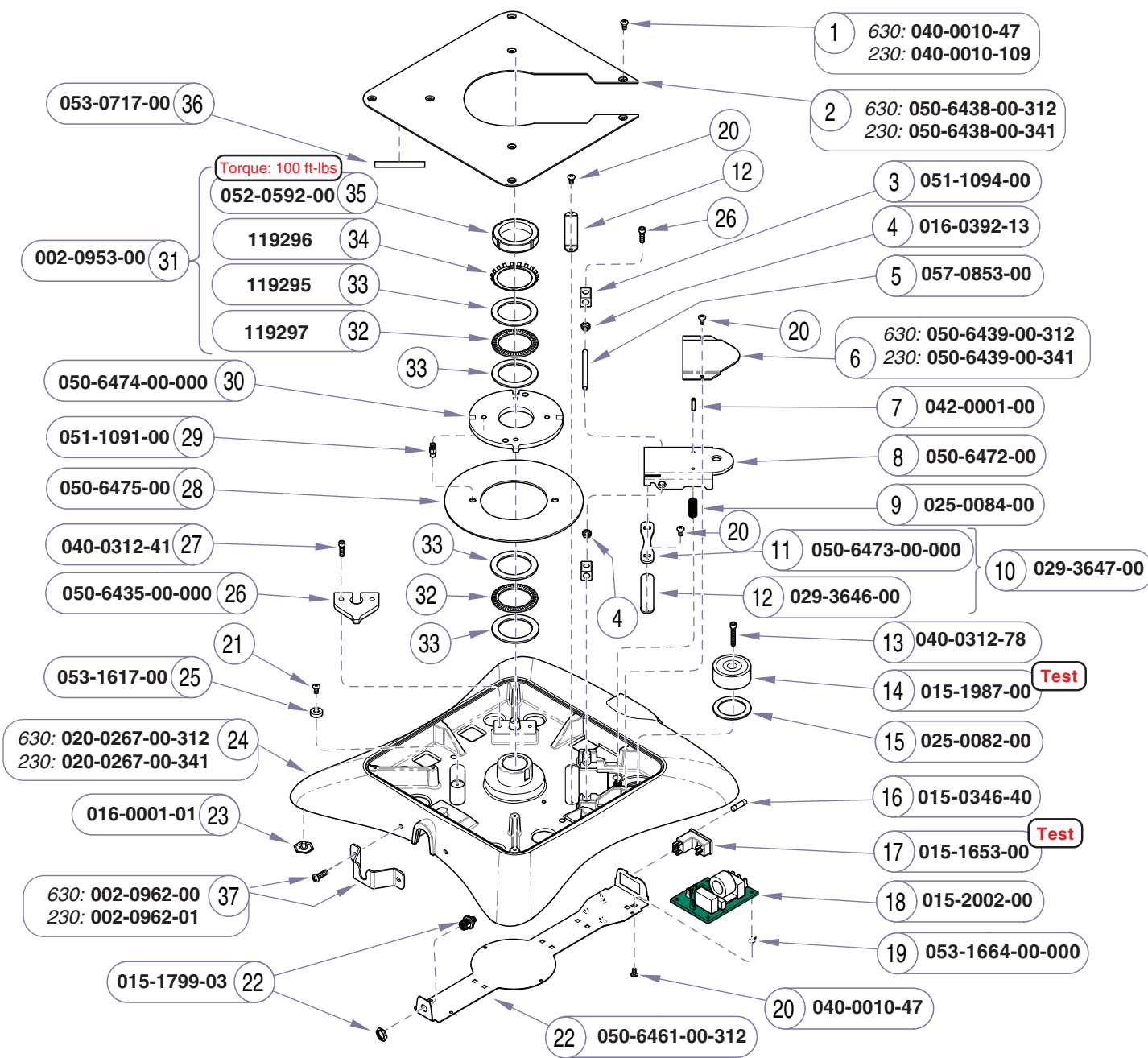

Item	Description	Qty.
1	Screw(#10-24 x 3/8")	5
2	Rotational Base Cover	1
3	Shaft Mount	2
4	DU Bearing	2
5	Bearing Shaft	2
6	Brake Lever Cover	1
7	Roll Pin	2
8	Brake Lever	1
9	Spring	2
10	Swivel Plate Assy (incl. items 11 & 12)	1
11	• Swivel Plate	1
12	• Brake Pad Assembly	2
13	Cap Screw (5/16"x18 x1 3/4")	1
14	Electromagnet Assembly	1
15	Wave Spring	1
16	Fuse (250V, 6.3A, Type-T, Slo-Blo)	2
17	Power Inlet	1
18	PC Board (inlet filter)	1
19	PC Board Standoff	4
20	Screw(#10-24 x 3/8")	14
21	Wire Trough Cover	1
22	I/O Harness Assembly	1
23	Leveling Screw	4
24	Lower Base	1
25	Delrin Spacer	1
26	Rotational Stop Bracket	1
27	Screw (5/16"-18 x 1")	4
28	Brake Disc	1
29	Brake Disc Shoulder Screw (apply Loctite 262 to threads)	2
30	Rotation Wheel	1
31	Bearing Kit (incl. items 32 thru 35)	1
32	• Thrust bearing	2
33	• Race Washer (2.75 id X 3.62 od)	4
34	• Lockwasher	1
35	• Lock Nut	1
36	Outer Seal	3
37	Control Cord Bracket Kit (incl. bracket & two #10-24 x 1/2" screws): a) Midmark models 1 b) Ritter models 1	1

MA710002i

Always Specify Model & Serial Number

**Rotational Base
Lower Section**

Models:	230 (-003)	630 (-005 & -006)
Serial Numbers:	All	All

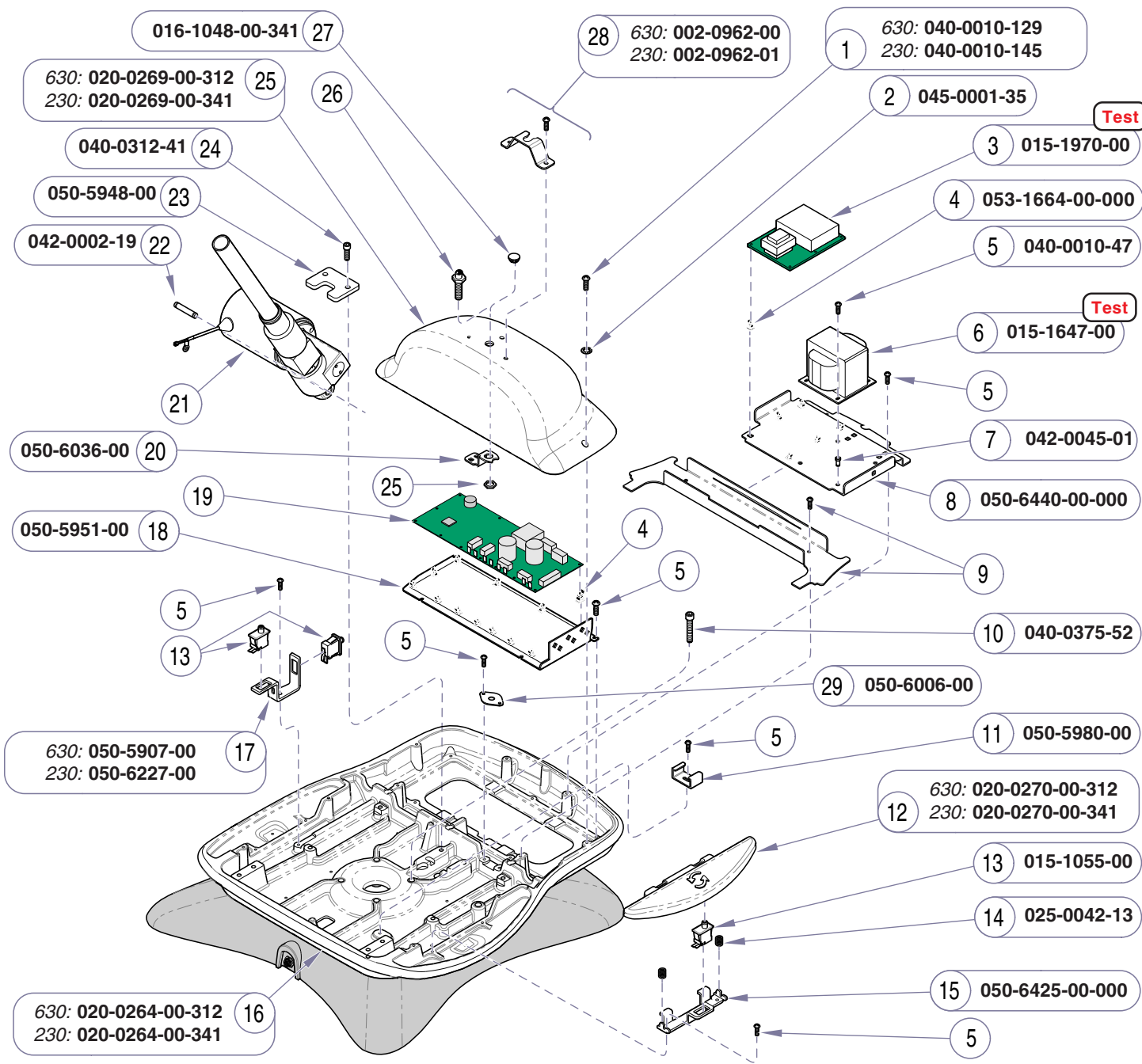

Refer To: **Page**
 Main System Transformer **Test** . B-30
 Rot. Base PC Board **Test** B-52
 Section D - *Wiring Diagrams*..... D-1
 Base Shrouds:
 Midmark models E-15
 Ritter models E-16
 Electrical Components E-23
 Base Actuator E-24*
 * multiple pages due to model / serial # break

Item	Description	Qty.
1	Screw (10-24 x .50 tt)	2
2	Lockwasher (#10 Int. tooth)	2
3	Rotation Control PC Board Assy.	1
4	PC Board Standoff	16
5	Screw (Pan hd phl. 10-24 X 3/8")	18
6	Main System Transformer Assy.	1
7	Nutsert (10-24)	4
8	Transformer Bracket	1
9	Refer to: <i>Base Shrouds</i>	Ref.
10	Bolt (3/8"-16 x 2")	4
11	Harness Clip	1
12	Brake Pedal	2
13	Limit Switch	4
14	Compression Spring	4
15	Switch Hinge Bracket	2
16	Upper Base Casting	1
17	Limit Switch Bracket	1
18	PC Board Base Plate	1
19	Refer to: <i>Electrical Components</i>	Ref.
20	Cable Holder (630 models only)	1
21	Refer to: <i>Base Actuator</i>	Ref.
22	Dowel Pin	1
23	Actuator Plate	1
24	Bolt (5/16"-18 x 1")	2
25	PC Board Cover	1
26	ConnectionPort / <i>Wiring Harness (incl. nut)</i> (Refer to Section D)	Ref.
27	Plug (230 models only)	1
28	Control Cord Bracket Kit (incl. bracket & two #10-24 x 1/2" screws): a) <i>Midmark models</i>	1
	b) <i>Ritter models</i>	1
29	Grounding Plate	1

MA710101i













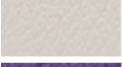

Models:	230 (-003)	630 (-005 & -006)
Serial Numbers:	All	All

Rotational Base Upper Section

Current Medical Color Palette:

Ritter Soft Touch & Seamless Upholstery

This chart shows all standard Ritter upholstery colors currently available.
Special order colors may be available at an additional charge.

<u>Color Sample</u>	<u>Color Name</u>	<u>Numeric Code (-xxx): Upholstery</u>	<u>Color Insert</u>
	Sand Grey	-200	-200
	Slate Grey	-201	-201
	Iris Blue	-202	-202
	Nile Green	-203	-203
	Terra Rosa	-204	-204
	Royal Lavendar	-205	-205
	Pebble Grey	-216	-216
	Perfect Plum	-229	-229
	Moss	-230	-230
	Navy	-231	-231
	Shadow	-232	-232
	Dusty Blue	-233	-233
	Clay	-234	-234
	Black	-312	-312

Effectivity
Date:

January 1, 2006 thru present























Ritter Color Palette:
Soft Touch & Seamless Uph.

© Midmark Corporation 2007

Current Medical Color Palette:

Midmark Premium Upholstery







This chart shows all standard Midmark Premium upholstery colors currently available. Special order colors may be available at an additional charge.

<u>Color Sample</u>	<u>Color Name</u>	<u>Numeric Code (-xxx): Upholstery</u>	<u>Color Insert</u>	<u>Color Sample</u>	<u>Color Name</u>	<u>Numeric Code (-xxx): Upholstery</u>	<u>Color Insert</u>
	Blueberry	-235	-235		Wedgewood	-206	-206
	Silver Sage	-236	-236		Monaco	-207	-207
	Tea Green	-237	-237		Royal Carriage	-208	-208
	Fossil Grey	-238	-238		Monet	-209	-209
	Cashmere Blue	-239	-239		Soft Pearl	-210	-210
	Terra Cotta	-240	-240		Waterford	-211	-206
	Belagio	-247	-247		English Gardens	-212	-207
	Siena	-248	-248		Cabernet	-213	-208
	Tuscany	-249	-249		Tapestry	-214	-209
	Firenze	-250	-250		Cathedral	-215	-210
	Capri	-251	-251				
	Treviso	-252	-252				
	Black	-312	-312				

Current Medical Color Palette:

Midmark Ultra-Premium Upholstery

This chart shows all standard Midmark Ultra-Premium upholstery colors currently available. Special order colors may be available at an additional charge.

Color Sample	Color Name	Numeric Code (-xxx): Upholstery	Color Insert
	Raven Wing	-228	-228
	Pacific Blue	-241	-235
	Spruce	-242	-242
	Olivine	-243	-237
	Arctic	-244	-244
	Sky	-245	-239
	Canyon	-246	-246

Effectivity
Date:

January 1, 2006 thru present

Midmark Color Palette:
Ultra-Premium Uph.

© Midmark Corporation 2007

Midmark Corporation
60 Vista Drive
P.O. Box 286
Versailles, OH 45380-0286
937-526-3662
Fax 937-526-5542
www.midmark.com



Because we care.