



Propaq[®] MD Service Manual



Use this manual with MP App software version 02.06.07.00 or higher.

The issue date for the Propaq MD Service Manual (**REF 9650-0807-01 Rev. C**) is **December, 2015**.

If more than 3 years have elapsed since the issue date, contact ZOLL Medical Corporation to determine if additional product information updates are available.

Copyright © 2015 ZOLL Medical Corporation. All rights reserved. Rectilinear Biphasic, SurePower, and ZOLL are trademarks or registered trademarks of ZOLL Medical Corporation in the United States and/or other countries.

Masimo and Rainbow are trademarks or registered trademarks of Masimo Corporation in the United States and/or other countries.

Propaq is a registered trademark of Welch Allyn Inc.



ZOLL Medical Corporation
269 Mill Road
Chelmsford, MA USA
01824-4105



ZOLL International Holding B.V.
Newtonweg 18
6662 PV ELST
The Netherlands



0123

Table of Contents

Preface

OVERVIEW	1
SAFETY CONSIDERATIONS	2
ADDITIONAL REFERENCE MATERIAL	2
CONVENTIONS	3
SERVICE POLICY WARRANTY	3
TECHNICAL SERVICE	3
TECHNICAL SERVICE FOR INTERNATIONAL CUSTOMERS	4

Chapter 1 Maintenance Tests

PROPAQ MD OVERVIEW	5
Before You Begin the Maintenance Tests	6
Equipment You Need to Perform the Maintenance Tests	7
Accessories You Need for the Propaq MD Options Maintenance Tests	7
MAINTENANCE TESTS	8
Physical Inspection of the Unit	8
Operational Tests	9
Leads Test	15
Heart Rate Display Test	16
Heart Rate Alarm Test	17
Power Supply Test	19
Leakage Current Test	21
Shock Test	22
Advisory Test	25
Synchronized Cardioversion Test	26
Pacer Test	27
Printer Test	28
Treatment Report Test	29
SpO ₂ Test (for SpO ₂ feature without SpCO and SpMet)	30
SpO ₂ , SpCO, and SpMet Tes (for SpO ₂ feature with SpCO, or SpCO and SpMet)	31
EtCO ₂ Calibration (required for annual calibration)	33
EtCO ₂ Calibration Check	34
EtCO ₂ Test	35
IBP Test	36
NIBP Calibration Check	37
NIBP Leak Test	40
Deflation Test	41

TABLE OF CONTENTS

Inflation Test	42
NIBP Test	43
Temperature Test	44
Wi-Fi Test (Optional)	45

Chapter 2 **Troubleshooting**

OVERVIEW	47
PROPAQ MD ERROR MESSAGES	47

Chapter 3 **Disassembly Procedures**

OVERVIEW	59
REQUIRED EQUIPMENT	59
SAFETY PRECAUTIONS	60
MODULES	60
REMOVING THE HANDLE	61
REMOVING THE PRINTER MODULE	62
DISASSEMBLING THE MAIN UNIT	64
REMOVING THE FRONT ENCLOSURE MODULE	68
REMOVING THE DISPLAY MODULE	70
REMOVING THE EtCO ₂ AND NIBP MODULES	74
REMOVING THE MONITOR BOARD AND SPO ₂ MODULES	78
REMOVING THE CP CARRIER MODULE	83
REMOVING THE DEFIBRILLATOR BOARDS AND CAPACITOR BANK MODULES	86
REMOVING THE AUX POWER CONNECTOR	92
REMOVING THE DOCK CONNECTOR	94

Chapter 4 **Replacement Parts**

OVERVIEW	97
Replacement Parts List	98
Pictures and Diagrams	102

Chapter 5 Functional Description

OVERVIEW	119
Circuit Distribution	119
Monitor Board	119
Defibrillator Pacer Module	122
Printer	123
Lithium Ion Battery	124

Appendix A

OVERVIEW	125
PROPAQ MD ELECTRICAL HARDWARE INTERCONNECT DIAGRAM	126
PROPAQ MD SIGNAL AND POWER INTERCONNECT SCHEMATIC	127

Appendix B

OVERVIEW	129
NIBP Simulator Performance	129
Fluke Biomedical BP Pump/Bio-Tek Instruments BP Pump	130
Fluke Biomedical BP Pump/Bio-Tek Instruments BP Pump2	130
Fluke Biomedical BP Pump/Dynatech Nevada Inc. CuffLink	131
Clinical Dynamics Smart Arm	131

Maintenance Test Checklist

OVERVIEW	133
----------------	-----

Preface

Overview

The ZOLL® Propaq® MD Service Manual is intended for the trained biomedical technician whose responsibility is to identify malfunctions and/or make repairs at the subassembly level. The Propaq MD Service Manual has five main sections and two appendixes.

Preface—Contains safety warnings and an overview of the manual's contents. Be sure to review this section thoroughly before attempting to use or service the Propaq MD unit.

Chapter 1—Maintenance Tests describes step-by-step procedures for various maintenance tests.

Chapter 2—Troubleshooting provides a listing of error messages to help the service technician detect faults and repair them.

Chapter 3—Disassembly Procedures describes step-by-step procedures for disassembling modules in the Propaq MD unit.

Chapter 4—Replacement Parts List displays a complete list of ZOLL part numbers for field replaceable parts available for the Propaq MD unit, allowing the service person to identify and order replacement parts from ZOLL.

Chapter 5—Functional Description provides technical descriptions for the Propaq MD major subassembly modules.

Appendix A—Propaq MD Electrical Hardware Interconnect Diagram and Propaq MD Signal and Power Interconnect Schematic.

Appendix B—Contains simulators and settings that may be used to assess the performance of the NIBP module.

Safety Considerations

The following section describes general warnings and safety considerations for operators and patients. Service technicians should review the safety considerations prior to servicing any equipment and read the manual carefully before attempting to disassemble the unit. Only qualified personnel should service the Propaq MD unit.

Federal (U.S.A.) law restricts this unit for use by or on the order of a physician.

Safety and effectiveness data submitted by ZOLL Medical Corporation to the Food and Drug Administration (FDA) under section 510(K) of the Medical Device Act to obtain approval to market is based upon the use of ZOLL accessories such as disposable electrodes, patient cables and batteries. The use of external pacing/defibrillation electrodes and adapter units from sources other than ZOLL is not recommended. ZOLL makes no representations or warranties regarding the performance or effectiveness of its products when used in conjunction with pacing/defibrillation electrodes and adapter units from other sources. If unit failure is attributable to pacing/defibrillation electrodes or adapter units not manufactured by ZOLL, this may void ZOLL's warranty.

Only qualified personnel should disassemble the Propaq MD unit.

WARNING! This unit can generate up to 2775 volts with sufficient current to cause lethal shocks.

All persons near the equipment must be warned to “STAND CLEAR” prior to discharging the defibrillator.

Do not discharge the unit’s internal defibrillator energy more than three times in one minute or damage to the unit may result.

Do not discharge a battery pack except in a ZOLL *SurePower™* Charging Station.

Do not use the Propaq MD in the presence of flammable agents (such as gasoline), oxygen-rich atmospheres, or flammable anesthetics. Using the unit near the site of a gasoline spill may cause an explosion.

Do not use the unit near or within puddles of water.

Additional Reference Material

In addition to this guide, there is a Propaq MD Operator’s Guide which is a comprehensive reference work that describes all the user tasks needed to operate the Propaq MD.

Conventions

WARNING! Warning statements describe conditions or actions that can result in personal injury or death.

Caution Caution statements describe conditions or actions that can result in damage to the unit.

Note: Notes contain additional information on using the defibrillator.

Service Policy Warranty

In North America: Consult your purchasing agreement for terms and conditions associated with your warranty. Outside of North America, consult a ZOLL authorized representative.

In order to maintain this warranty, the instructions and procedures contained in this manual must be strictly followed. For additional information, please call the ZOLL Technical Service Department 1-800-348-9011 in North America.

Technical Service

If the ZOLL Propaq MD unit requires service, contact the ZOLL Technical Service Department:

Telephone: 1-978-421-9655; 1-800-348-9011

Fax: 1-978-421-0010

Email: techsupport@zoll.com

Have the following information available for the Technical Service representative:

- Unit serial number.
- Description of the problem.
- Department where equipment is used.
- Sample chart recorder strips or electronic log files documenting the problem, if applicable.
- Purchase Order to allow tracking of loan equipment.
- Purchase Order for a unit with an expired warranty.

If the unit needs to be sent to ZOLL Medical Corporation, obtain a service request number (SR#) from the Technical Service representative. Return the unit in its original container to:

ZOLL Medical Corporation
269 Mill Road
Chelmsford, Massachusetts 01824-4105

Attn: Technical Service Department (SR#)

Telephone: 1-800-348-9011; 1-978-421-9655 FAX: 978-421-0010

Technical Service for International Customers

International customers should return the unit in its original container to the nearest authorized ZOLL Medical Corporation Service Center. To locate an authorized service center, contact the International Sales Department at ZOLL Medical at the above address.

Tamper Proof Labels



ZOLL products must be repaired by qualified individuals. The removal of the tamper proof label could result in voiding the factory warranty. Please contact the Technical Service Department if you have any questions or concerns prior to removing the label.

Chapter 1

Maintenance Tests

Propaq MD Overview

This chapter includes step-by-step procedures for various maintenance tests. At a minimum, a trained biomedical technician must perform a CO₂ calibration and an NIBP calibration check once per year. A CO₂ calibration check may be performed at any time to verify the CO₂ calibration. It is necessary to perform maintenance tests after a module is repaired to ensure that the functions of the Propaq MD unit work properly. Use the checklist at the back of this document (ZOLL Propaq Maintenance Tests Checklist) to record your results of the maintenance tests.

Because the Propaq MD units must be maintained ready for immediate use, it is important for users to conduct the Operator's Shift Checklist procedure at the beginning of every shift. This procedure can be completed in a few minutes and requires no additional test equipment. (See the ZOLL Propaq MD Operator's Guide for the Operator's Shift Checklist.)

This chapter describes the following maintenance tests:

- 1.0 Physical Inspection of the Unit
- 2.0 Operational Tests
- 3.0 Leads Test
- 4.0 Heart Rate Display Test
- 5.0 Heart Rate Alarm Test
- 6.0 Power Supply Test
- 7.0 Leakage Current Test
- 8.0 Shock Test
- 9.0 Advisory Test
- 10.0 Synchronized Cardioversion Test
- 11.0 Pacer Test
- 12.0 Printer Test
- 13.0 Treatment Report Test
- 14.0 SpO₂ Test (for SpO₂ feature without SpCO and SpMet)
- 15.0 SpO₂, SpCO, and SpMet Test (for SpO₂ feature with SpCO, or SpCO and SpMet)
- 16.0 EtCO₂ Calibration (required for annual calibration)
- 17.0 EtCO₂ Calibration Check
- 18.0 EtCO₂ Test
- 19.0 IBP Test
- 20.0 NIBP Calibration Check
- 21.0 NIBP Leak Test
- 22.0 Deflation Test
- 23.0 Inflation Test
- 24.0 NIBP Test
- 25.0 Temperature Test
- 26.0 Wi-Fi Test (Optional)

Before You Begin the Maintenance Tests

- Assemble the tools listed in following section, “Equipment You Need to Perform the Maintenance Tests.”
- Keep an extra fully charged SurePower II battery available.
- Schedule an hour to conduct the entire maintenance test.
- Perform the tests in the order presented.
- Perform all the steps of each test procedure.
- Complete all the steps of the procedure before evaluating the test results.

Equipment You Need to Perform the Maintenance Tests

The equipment listed below is used in the maintenance procedures in this chapter. You can substitute an equivalent device; however, not all simulators and analyzers will produce the same results. Be sure to follow the manufacturer's recommendations for conducting the maintenance tests.

- Fluke Impulse 7000DP Analyzer, with appropriate interface adapter (Fluke Biomedical BP Pump/Dynatech Nevada Inc. part number 3010-0378)
- ECG simulator
- Fluke Index 2 SpO₂ simulator
- IBP/Temp simulator
- NIBP simulator
- 5% CO₂ calibration gas cylinder with CO₂ sample line (kit available from Scott Medical Products, PN 4653ORF-BD)
- CO₂ sampling line airway adapter
- Stop watch
- Battery Current Test Fixture 9100-3055-TF
- Agilent E3633A Power Supply (12V rated for 10A)
- Agilent 34401 Digital Multi-meter

Accessories You Need for the Propaq MD Options Maintenance Tests

- 3-lead, 5-lead and 12-lead ECG cables. (12-lead cable needed if 12-lead option is installed.)
- Dual lumen NIBP hose
- IBP cable
- SpO₂ cable and sensor
- EtCO₂ cable and sensor
- Paddles
- Printer paper
- Battery
- Auxiliary power source
- USB thumb drive

Maintenance Tests

1.0 Physical Inspection of the Unit

	Observe this...	Pass/Fail
	Housing	
1.1	Is the unit clean and undamaged?	O O
1.2	Does the unit show signs of excessive wear?	O O
1.3	Does the handle work properly?	O O
1.4	Does the recorder drawer open and close properly?	O O
1.5	Are input connectors clean and undamaged?	O O
1.6	Are there any cracks in the housing?	O O
1.7	Does the front panel have any damage or cracks?	O O
1.8	Are there any loose housing parts?	O O
1.9	Paddles (if applicable) Do the adult and pedi plates have major scratches or show signs of damage?	O O
1.10	Do the adult shoes slide on and off easily to expose the covered pedi plates?	O O
1.11	Are the paddles clean (e.g., free of gel) and undamaged? (if applicable)	O O
1.12	Cables Are all cables free of cracks, cuts, exposed or broken wires?	O O
1.13	Are all bend/strain reliefs undamaged and free of excessive cable wear?	O O
1.14	Battery Is the Propaq MD battery fully charged?	O O
1.15	Is the battery seated in the battery well correctly?	O O
1.16	Is battery housing free of cracks and damage?	O O
1.17	Are connectors free of damage and excessive wear?	O O



2.0 Operational Tests

The Propaq MD unit comes equipped with routine operational tests that can be performed periodically. With the exception of the Physical Inspection of the Unit test, these tests contain instructions within them that provide guidance during the tests.

The operational tests on the unit can be accessed by doing the following:

1. Turn on the Propaq MD unit.

Note: If the unit is in AED mode, press the **Manual** quick access key to go into manual mode. Use the navigation keys to select the four digits in the Manual Mode pass code. Press **SAVE** when you are finished. If the unit has not been configured to enter a pass code, the message *Exit to Manual Mode* is displayed. Use the navigation keys to select **Yes**.

2. Press the More () then the Setup () quick access keys.

3. Use the navigation keys to select **Supervisor>Service>Device Tests**. The operational tests are displayed. Use the navigation keys to select one of the tests.

Note: You need a supervisor passcode to enter the Supervisor menu.

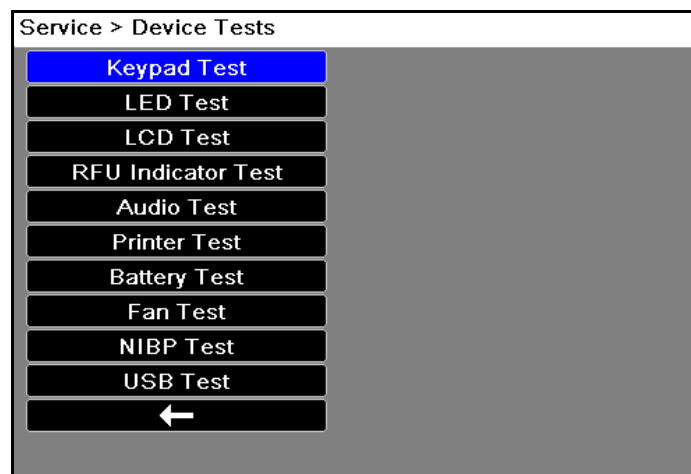

2.1 Keypad Test

This test checks all the front panel buttons on the unit to make sure they are working correctly.

Follow the instructions and use the navigation keys to move around the display and make selections.

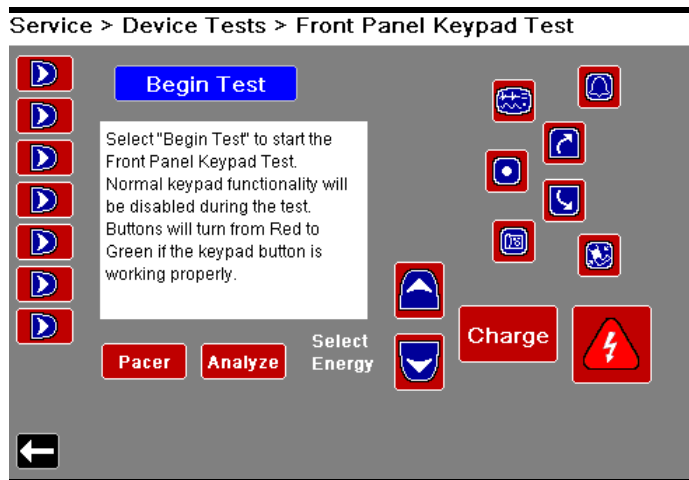

Note: To exit screen after test is complete, press the “Enter” button 3 times to display arrow.

2.2 LED Test

This test checks all the Light Emitting Diodes in the unit to make sure they are working correctly.

Follow the instructions and use the navigation keys to move around the display and make selections.

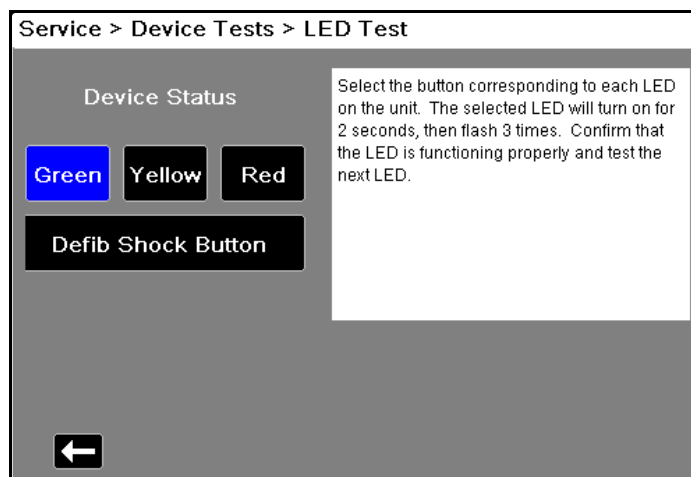

Note: The speed of the flash varies by color.

2.3 LCD Test

This test checks the colors of the Liquid Crystal Display on the unit.

Follow the instructions and use the navigation keys to move around the display and make selections.

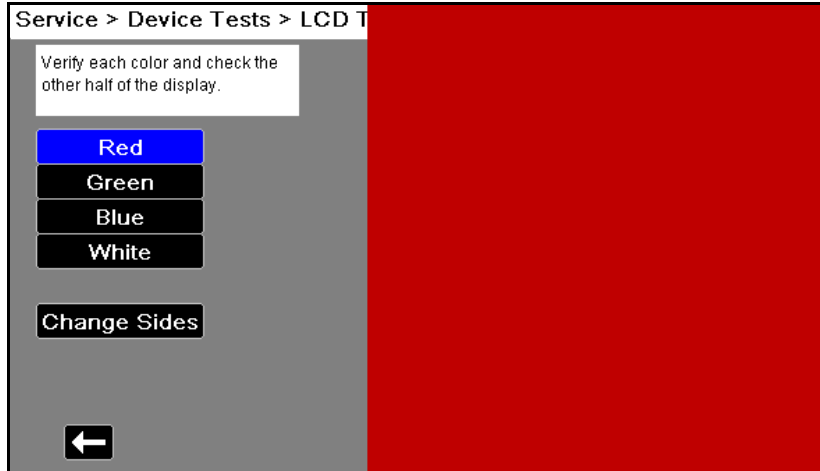

2.4 RFU Indicator Test

This test checks the Ready For Use Indicator on the unit to make sure it is working correctly.

Follow the instructions shown on the display.

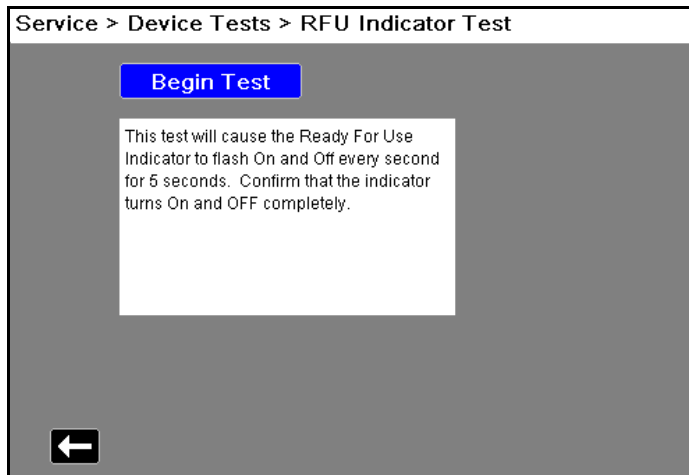

2.5 Audio Test

This test checks the audio tones on the unit to make sure they are working correctly.

Follow the instructions and use the navigation keys to move around the display and make selections.

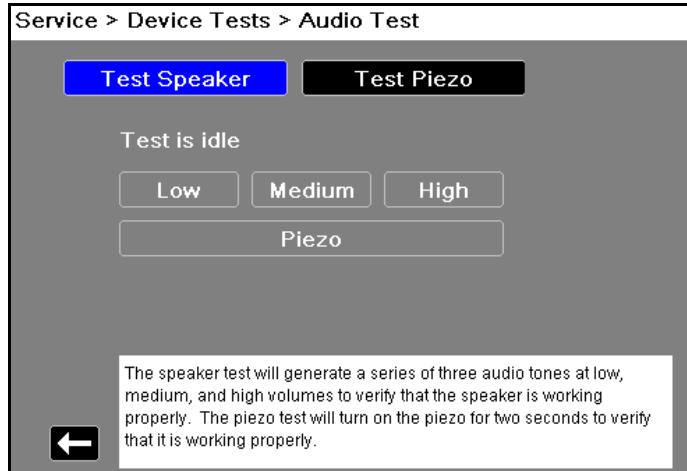

2.6 Printer Test

This test checks the printer to make sure it is working correctly.

Follow the instructions shown on the display.

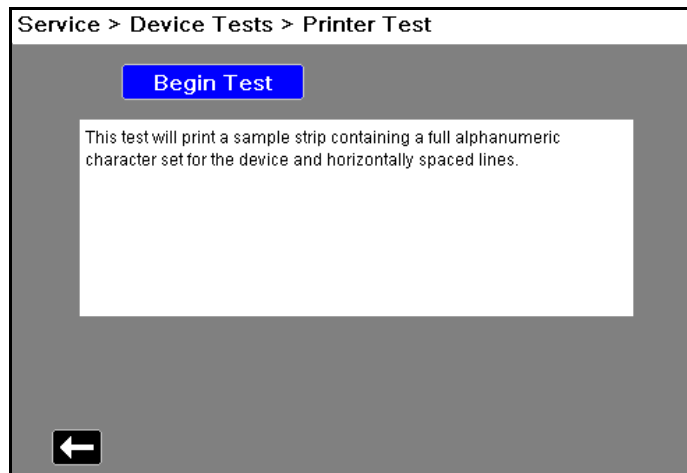

2.7 Battery Test

This test checks the battery to make sure it is working correctly.

Follow the instructions on the display.

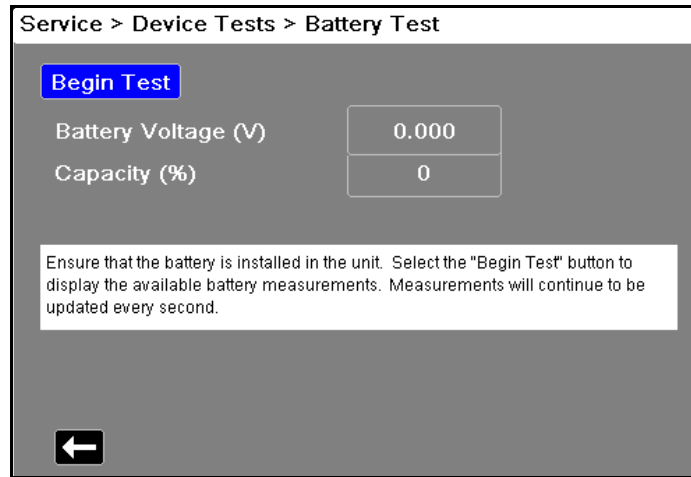

2.8 Fan Test

This test checks the fan in the unit to make sure it is working correctly.

Follow the instructions and use the navigation keys to move around the display and make selections.

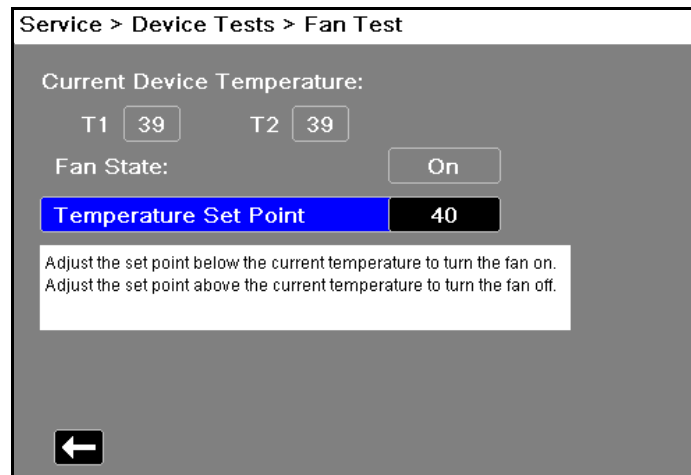

2.9 USB Test (Optional)

Note: Before starting this test, contact the ZOLL Technical Service Department to obtain a test file, or create a file (see instructions below). Once you have obtained a copy, save it on a USB thumb drive.

This test allows you to perform the USB test to make sure it is working correctly.

Follow the instructions and use the navigation keys to move around the display and make selections.

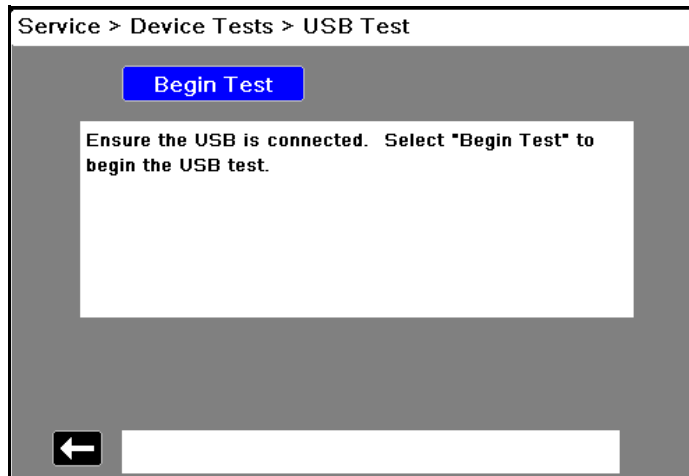

When these tests are completed, use the navigation keys to exit out of the Service menu.

Creating a Test File



1. Create a Text file using Microsoft Notepad.
2. Open new file in Notepad.
3. Click in the first line of the file and type "Thunderbolt Testfile".
4. Save file as Tbolt_usb.txt.

3.0 Leads Test

Equipment 3-lead, 5-lead, and 12-lead cables, Fluke Impulse 7000DP Analyzer

Note: Test each cable separately.

Test Setup Connect the lead wires appropriate for each test to the Fluke Impulse 7000DP Analyzer or equivalent, then connect the ECG cable to the Propaq MD unit.

	Do this...	Observe this...	Pass/Fail
3.1	Turn on the Propaq unit. Note: Make sure the lead is not displayed.	No ECG LEAD FAULT message displayed.	O O
3.2	Disconnect one lead from the simulator.	The ECG LEAD FAULT message displays within 3 seconds (if configured).	O O
3.3	Reconnect the lead. Repeat step 2 with the remaining leads.	Wait for ECG LEAD FAULT message to clear from the display (if configured).	O O
3.4	Repeat steps 2 and 3 for 5 lead and 12 lead cables.	Note: If heart rate alarm sounds, on the Propaq unit: Press the More quick access key () key to access the second set of quick access keys. Press the Alarm quick access key (). Press the Alarm Cancel quick access key ().	O O

4.0 Heart Rate Display Test







Equipment Fluke Impulse 7000DP Analyzer
 ECG Cable (3-lead, 5-lead or 12-lead)

Test Setup Press Lead quick access key until **II** displays.
 Connect the ECG leads to the ECG studs on Analyzer.

	Do this...	Observe this...	Pass/Fail
4.1	Set the ECG Simulator to 120BPM.	The Heart Rate displays as 120 +/- 4 bpm.	<input type="radio"/> <input type="radio"/>

5.0 Heart Rate Alarm Test

Equipment Fluke Impulse 7000DP Analyzer

	Do this...	Observe this...	Pass/Fail
5.1	Press the Leads quick access key () on the Propaq unit and select lead II.	II displays next to the Leads quick access key.	O O
5.2	On the Propaq unit: <ul style="list-style-type: none"> • Press the More quick access key () key to access the second set of quick access keys. • Press the Alarm quick access key (). • Press the Limits softkey. 	The Alarm Settings menu displays.	O O
5.3	On the Propaq unit, select HR/PR Alarm in the Alarm Settings menu and use the navigation keys to do the following: <ul style="list-style-type: none"> • Set the Upper Limit Enable to ON. • Set the Lower Limit Enable to ON. • Set the Lower limit to 35. • Set the Upper limit to 150. Use the navigation keys to exit the Alarm Settings menu.		
5.4	On the Propaq unit, press the Alarm Cancel quick access key ().	The red alarm suspension timer displays at the top of the screen next to the message area.	
5.5	Remove a lead wire from the ECG simulator.	The <i>ECG LEAD FAULT</i> message displays.	O O
5.6	On the Propaq unit, press  .	The Alarm Suspend key flashes.	
5.7	Reattach ECG Lead wire to ECG simulator.	The <i>ECG LEAD FAULT</i> message no longer displays.	O O
5.8	Set simulator to 30 BPM or lower.	Heart Rate Value is highlighted and the alarm tone sounds. The <i>HR/PR LOW ALARM</i> message displays.	
5.9	On the Propaq unit, press  .	The Alarm Suspend key flashes. The red alarm suspension timer displays at the top of the screen next to the message area.	O O
5.10	Set the simulator to 120 BPM.		
5.11	On the Propaq unit, press  .	Alarm is enabled. The alarm suspend key flashes. The alarm suspension timer disappears.	O O

	Do this...	Observe this...	Pass/Fail
5.12	Set simulator to 160 BPM or higher.	Heart Rate Value is highlighted and the alarm tone sounds. The <i>HR/PR HIGH ALARM</i> message displays.	O O
5.13	On the Propaq unit, press the Alarm Silence/Reset button ().	Alarm is suspended for 90 seconds. The alarm suspension timer appears in black.	O O

6.0 Power Supply Test

Equipment Battery Current Test Fixture (P/N 9100-3055-TF), Power Supply, Digital Multi-meter.

Test Setup

1. Set the Power Supply to 12V VDC
2. Turn off the Power Supply output.
3. Connect the positive (PS+) post of the Power Supply to the positive (PS+) post (PS Red) of the Battery Current Test Fixture.
4. Connect the negative (PS-) post of the Power Supply to the negative (PS-) post (PS Black) of the Battery Current Test Fixture.
5. With the Battery Current Test Fixture out of the battery well, turn on the Power Supply output.
6. Wait 5 seconds, then press the charge capacity switch on the Battery Current test fixture and verify that the green LEDs momentarily turn on.
7. Set the Digital Multi-meter to measure *DC I DC* Amps.
8. Set the rear/front switch on the Digital Multi-meter to rear.
9. Connect the Digital Multi-meter (I+) terminal of the Battery Current Test Fixture to the red terminal (I) on the back of the Digital Multi-meter.
10. Connect Digital Multi-meter (I-) terminal of the Battery Current Test Fixture to the black terminal (LO) on the back of the Digital Multi-meter.

	Do this...	Observe this...	Pass/Fail
6.1	Install the Battery Current Test Fixture into battery well and wait about five seconds.		
6.2	Make sure the Propaq unit is turned off. Ensure that paper is loaded in the printer and the printer door is closed.		
6.3	Press the <i>I Measure</i> switch on the Battery Current Test Fixture.	Verify that the reading on the digital multi-meter is between 0.583mA-0.770mA.	o o
6.4	Turn on the Propaq unit, and wait about ten seconds until the power has stabilized.		

	Do this...	Observe this...	Pass/Fail
6.5	<p>Ensure that the unit is in the following configuration:</p> <ol style="list-style-type: none"> Brightness () set to color display. Display brightness is set to the factory default setting 70% (in Setup>Display\Volume>Display) Ensure that no parameters are active/running. 		
6.6	Press the <i>I Measure</i> switch on the Battery Current Test Fixture.	Observe the current measurement on the DMM, and verify that the reading is between 0.47A-1.25A.	O O
6.7	Return brightness levels to previous settings (if changed in 6.5).		

7.0 Leakage Current Test

Equipment See the manufacturer’s instructions or supplied specifications for the leakage tester you use.

Setup See the manufacturer’s instructions or supplied specifications for the leakage tester you use. Repeat leakage test with accessories: MFC, external paddles, internal paddles, and anterior/posterior paddles. Perform these tests at the line-power voltage and frequency used in your installation.

Maximum Leakage Acceptance Limits			
	Patient Leakage		Mains on Applied Part
	Normal	Single Fault	Single Fault
ECG	10 μ A	50 μ A	100 μ A
MFC	10 μ A	50 μ A	100 μ A

	Normal	Single Fault
Earth Leakage	2500 μ A	5000 μ A

8.0 Shock Test

WARNING! Take the necessary precautions to guard against shock or injury before you start conducting the defibrillator tests.

Keep hands and all other objects clear of the multi-function cable connections and defibrillator analyzer when discharging the defibrillator.

Before you discharge the defibrillator, warn everyone near the equipment to **STAND CLEAR**.

Equipment Fluke Impulse 7000 DP Analyzer (or equivalent), stop watch

	Do This...	Observe This...	Pass/Fail
8.1	Turn on the Analyzer.		
8.2	On the Analyzer, select the DEFIB function.		
8.3	On the Analyzer, select ENERGY.		
8.4	Connect the Propaq MFC connector to the pads connection.		
8.5	On the Propaq unit, apply power to the unit using a battery or an AC adapter.		
8.6	Connect the MFC cable to the Propaq unit.		
8.7	Turn on the Propaq unit, and press the Leads quick access key () to select PADS .		
8.8	On the Propaq unit, set energy level to 5J by pressing the Energy Select DOWN arrow.		
8.9	On the Propaq unit, press the CHARGE button.	The unit charges to 5J, the red Shock button illuminates and a ready tone sounds.	o o
8.10	On the Propaq unit, press the Shock button.		
8.11	On the Analyzer, observe and record the energy measurement.	Energy is delivered at 5J. Verify that the delivered energy is within 15% based on the impedance values of your analyzer in the table “Delivered Energy at 200J Defibrillator Setting into a Range of Loads” on page 24.	o o
8.12	On the Propaq unit, set the energy level to 50J by pressing the Energy Select UP arrow.		
8.13	On the Propaq unit, press the CHARGE button.	The unit charges to 50J, the red Shock button illuminates and a ready tone sounds.	o o

	Do This...	Observe This...	Pass/Fail
8.14	On the Propaq unit, press the Shock button.		
8.15	On the Analyzer, observe and record the energy measurement.	Energy is delivered at 50J. Verify that the delivered energy is within 15% based on the impedance values of your analyzer in the table “Delivered Energy at 200J Defibrillator Setting into a Range of Loads” on page 24.	o o
8.16	On the Propaq unit, set energy level to 100J by pressing the Energy Select UP arrow.		
8.17	On the Propaq unit, press the CHARGE button.	The unit charges to 100J, the Shock button illuminates and a ready tone sounds.	o o
8.18	On the Propaq unit, press the Shock button.		
8.19	On the Analyzer, observe and record the energy measurement.	Energy is delivered at 100J. Verify that the delivered energy is within 15% based on the impedance values of your analyzer in the table “Delivered Energy at 200J Defibrillator Setting into a Range of Loads” on page 24.	o o
8.20	On the Propaq unit, set energy level to 200J by pressing the Energy Select UP arrow.		
8.21	On the Propaq unit, press the CHARGE button.	The unit charges to 200J, the red Shock button illuminates and a ready tone sounds.	o o
8.22	On the Propaq unit, press the Shock button.		
8.23	On the Analyzer, observe and record the energy measurement.	Energy is delivered at 200J. Verify that the delivered energy is within 15% based on the impedance values of your analyzer in the table “Delivered Energy at 200J Defibrillator Setting into a Range of Loads” on page 24.	o o
8.24	On the Propaq unit, press the CHARGE button.	The unit charges to 200J, the red Shock button illuminates, and a ready tone sounds.	o o
8.25	When the Propaq unit is charged, start the stop watch.	Verify that after 50 seconds the tone changes and within 10 seconds the unit does an internal discharge and displays <i>DISARMED TIMEOUT</i> .	o o

	Do This...	Observe This...	Pass/Fail
8.26	Turn off the Propaq unit.		

Delivered Energy at 200J Defibrillator Setting into a Range of Loads

Selected Energy	Load							Accuracy*
	25Ω	50Ω	75Ω	100Ω	125Ω	150Ω	175Ω	
5 J	3 J	5 J	6 J	6 J	6 J	6 J	6 J	±15%
50 J	35 J	54 J	59 J	61 J	62 J	61 J	59 J	±15%
100 J	71 J	109 J	119 J	122 J	125 J	123 J	119 J	±15%
200 J	142 J	230 J	249 J	253 J	269 J	261 J	260 J	±15%

Note: For a complete listing of Propaq Delivered Energy at Every Defibrillator Setting into a Range of Loads, see Appendix A in the *Propaq Operator's Guide*.

9.0 Advisory Test

Equipment Fluke Impulse 7000 DP Analyzer (or equivalent), ECG simulator

	Do This...	Observe This...	Pass/Fail
9.1	Connect the multifunction cable (MFC) to the Analyzer.		
9.2	Turn on the Propaq unit and connect the pads.	The unit displays Pads on the top left of the screen.	o o
9.3	On the Analyzer, select VF (ventricular fibrillation), then press the Analyze button.	The Propaq unit displays: <i>ANALYZING</i> <i>SHOCK ADVISED</i>	o o
9.4	On the Propaq unit, press the CHARGE button to activate, then press the CHARGE button again.	The unit charges to the selected energy level.	o o
9.5	On the Propaq unit, press the Shock button.	Verify that the shock count is displayed at the top of the screen.	o o
9.6	On the Analyzer, select NSR (normal sinus rhythm), then press the Analyze button.	The Propaq unit displays: <i>ANALYZING</i> <i>NO SHOCK ADVISED</i>	o o

10.0 Synchronized Cardioversion Test

Equipment Fluke Impulse 7000DP Analyzer (or equivalent)

Test Setup Connect the cable to the defibrillator analyzer.

Select Sync mode on analyzer. Input 1mV ECG signal at 60 BPM.

	Do this...	Observe this...	Pass/Fail
10.1	Verify that the Propaq unit is turned on and the PADS lead is selected.		
10.2	Press the SYNC softkey on the defibrillator. Enter the synchronized cardioversion timing test mode on the defibrillator analyzer.	Sync appears on display. Sync markers display on the monitor. The sync marker appears as an S over the ECG R-wave peaks on strip chart and display.	O O
10.3	Select 200J.		
10.4	Press the CHARGE button. When the Shock button illuminates, press and hold it.	Observe that the R-wave to shock delay (sync delay) is less than 60 milliseconds on the analyzer display. Defibrillator discharges.	O O



11.0 Pacer Test

Equipment Fluke Impulse 7000 DP Analyzer (or equivalent)

	Do This...	Observe This...	Pass/Fail
11.1	On the Analyzer, select the PACER function per test equipment instructions.		
11.2	On the Analyzer, press F2 to select PACER JACKS, then press F5 (Done) to measure pulse.		
11.3	Connect the MFC connector to the Analyzer.		
11.4	On the Propaq unit, apply power to the unit using a battery or an AC adapter.		
11.5	On the Propaq unit, press the PACER button.		
11.6	On the Propaq unit, use the navigation keys to do the following: <ul style="list-style-type: none"> •Set Rate to 30. •Set Mode to Fixed. •Set Output to 10. •Select Start Pacer. 		O O
11.7	On the Impulse 7000 DP Analyzer, record the following: <ul style="list-style-type: none"> •pulse rate •pacer amplitude output •pacer pulse width 	<ul style="list-style-type: none"> •Pacer Rate PPM (28.5ppm-31.5ppm) •Pacer amplitude output (5mA-15mA) •Pacer pulse width (38ms to 42ms) <p>Note: If an <i>ECG FAULT</i> message displays when leads are not attached, it is normal.</p>	
11.8	On the Propaq unit, use the navigation keys to do the following: <ul style="list-style-type: none"> •Set Rate to 180. •Set Output to 140. 		O O
11.9	On the Impulse 7000 DP Analyzer, record the following: <ul style="list-style-type: none"> •pulse rate •pacer amplitude output •pacer pulse width 	<ul style="list-style-type: none"> •Pacer Rate PPM (162ppm-198ppm) •Pacer amplitude output (133mA-147mA) •Pacer pulse width (38ms to 42ms) 	
11.10	Select Turn Pacer Off .		







12.0 Printer Test

Equipment None

	Do this...	Observe this...	Pass/Fail
12.1	On the Propaq unit, verify that paper is installed.		
12.2	Press the Print quick access key () to start the recorder. Note: If the printer fails to start, check <i>setup for printer=yes</i> .		
12.3	Press the Print quick access key () to stop the recorder after approximately 10 seconds.	The printout on the strip chart is clear and dark.	O O

13.0 Treatment Report Test

Equipment Fluke Impulse 7000 DP Analyzer (or equivalent)

	Do this...	Observe this...	Pass/Fail
13.1	Connect the multifunction cable (MFC) to the Analyzer, and turn on the Analyzer.		
13.2	Turn on the Propaq unit, and press the following quick access keys: a)  b)  c) 	The Clear Log window displays.	
13.3	Select Yes .	The unit displays a clearing the log message.	O O
13.4	Press the CHARGE button, select 200 joules, then press the CHARGE button again.	The unit starts to charge, a charging tone sounds, and the Shock button illuminates.	O O
13.5	Press the Shock button.	The unit discharges the shock.	O O
13.6	Wait 20 seconds, press the Treatment quick access key(), and select the first code marker.		
13.7	Wait 15 seconds and turn off the unit, then wait 2 minutes and turn on the unit.		
13.8	On the Propaq unit, press the following quick access keys: a)  b)  c) 	The Treatment Summary window displays.	O O
13.9	Highlight the second event and press Select .	Verify that a green check mark displays next to the file.	O O
13.10	Select Print Treatment Summary .	Verify that the recorder prints out the defib event and the code marker snapshot.	O O
13.11	Turn off the Propaq unit.		

14.0 SpO₂ Test (for SpO₂ feature without SpCO and SpMet)

Note: Perform this test if your unit has SpO₂ only. See the following procedure to test units with SpO₂, SpCO, and SpMet.

Equipment Fluke Index 2 SpO₂ Simulator (or equivalent), Masimo[®] Rainbow[®] SpO₂ finger probe

Test Setup Disconnect any ECG cable or IBP probes from the Propaq unit.

	Do This...	Observe This...	Pass/Fail
14.1	Power on the Propaq unit without the SpO ₂ sensor attached.	Verify that the SpO ₂ numeric displays INITIALIZING, then goes blank.	
14.2	Connect the SpO ₂ sensor to the Propaq unit.	Verify that SpO ₂ numeric displays SEARCHING.	
14.3	Set the simulator to 70% SpO ₂ and 60 PPM. Attach the SpO ₂ sensor to the simulator.	Verify that after a brief period of initialization, the SpO ₂ numeric displays an SpO ₂ value between 67% and 73%. Verify that the displayed pulse rate reads 60 +/- 3 bpm.	O O O O
14.4	Set the simulator to 80% SpO ₂ and 60 PPM.	Verify that after a brief period of initialization, the SpO ₂ numeric displays an SpO ₂ value between 77% and 83%. Verify that the displayed pulse rate reads 60 +/- 3 bpm.	O O O O
14.5	Set the simulator to 90% SpO ₂ and 60 PPM.	Verify that after a brief period of initialization, the SpO ₂ numeric displays an SpO ₂ value between 87% and 93%. Verify that the displayed pulse rate reads 60 +/- 3 bpm.	O O O O
14.6	Disconnect the SpO ₂ simulator.		

15.0 SpO₂, SpCO, and SpMet Test (for SpO₂ feature with SpCO, or SpCO and SpMet)

Note: Use this test if your unit has SpO₂ and SpCO, or SpO₂, SpCO and SpMet. If you do not have the SpMet feature on the unit, disregard the SpMet values in the test below.

Equipment Fluke Index 2 SpO₂ Simulator (or equivalent), Masimo Rainbow 3 ft BioTek Test Sensor (Masimo P/N 3379) or Masimo Rainbow 3 ft Direct Connect Optical Test Sensor

Test Setup Disconnect any ECG cable or IBP probes from the Propaq unit.

	Do This...	Observe This...	Pass/Fail/N/A
15.1	Power on the Propaq unit without the SpO ₂ sensor attached.	Verify that the SpO ₂ numeric displays <i>INITIALIZING</i> , then goes blank.	
15.2	Connect the SpO ₂ sensor to the Propaq unit.	Verify that SpO ₂ numeric displays <i>SEARCHING</i> .	
15.3	Set the simulator to 75% SpO ₂ and 50 BPM. Attach the SpO ₂ sensor to the simulator.	Verify that after a brief period of initialization, The SpO ₂ numeric displays an SpO ₂ value between 72.1% and 78%. The SpCO numeric displays an SpCO value between 13.5 and 21.5. The SpMet numeric displays an SpMet value between 5.5 and 9.5. Verify that the displayed pulse rate reads between 44.5 and 55.5 BPM.	 O O O O O O O O O
15.4	Set the simulator to 75% SpO ₂ and 230 BPM.	Verify that after a brief period of initialization, The SpO ₂ numeric displays an SpO ₂ value between 72.1% and 78%. The SpCO numeric displays an SpCO value between 12.8 and 20.8. The SpMet numeric displays an SpMet value between 5.2 and 9.2. Verify that the displayed pulse rate reads between 222.7 and 236 BPM.	 O O O O O O O O O

	Do This...	Observe This...	Pass/Fail/N/A
15.5	Set the simulator to 95% SpO ₂ and 230 BPM.	<p>Verify that after a brief period of initialization, The SpO₂ numeric displays an SpO₂ value between 91.3% and 98.8%. The SpCO numeric displays an SpCO value between 0.0 and 7.5. The SpMet numeric displays an SpMet value between 0.0 and 3.5.</p> <p>Verify that the displayed pulse rate reads between 222.7 and 236 BPM.</p>	<p>o o</p> <p>o o</p> <p>o o o</p> <p>o o</p>
15.6	Set the simulator to 95% SpO ₂ and 50 BPM.	<p>Verify that after a brief period of initialization, The SpO₂ numeric displays an SpO₂ value between 91.3% and 98.8%. The SpCO numeric displays an SpCO value between 0.0 and 7.5. The SpMet numeric displays an SpMet value between 0.0 and 3.5.</p> <p>Verify that the displayed pulse rate reads between 44.5 and 55.5 BPM.</p>	<p>o o</p> <p>o o</p> <p>o o o</p> <p>o o</p>
15.7	Disconnect the SpO ₂ simulator.		

16.0 EtCO₂ Calibration (required for annual calibration)

Equipment 5% CO₂ calibration gas cylinder with CO₂ sample line (kit available from Scott Medical Products, PN 4653ORF-BD)

	Do This...	Observe This...	Pass/Fail
16.1	Turn on the Propaq unit.		
16.2	On the Propaq unit, select Supervisor>Service>Diagnostic>CO₂>Calibration to enter the CO ₂ Calibration control panel.		
16.3	Connect the Propaq unit to the 5% CO ₂ calibration gas cylinder using the sample line included with the calibration kit.		
16.4	From the CO ₂ Calibration Menu, select Calibration .		
16.5	Activate the calibration gas flow by pressing the top valve on the calibration gas canister.		
16.6	Continue to apply the calibration gas until the status in the CO ₂ Calibration control panel displays: <i>CALIBRATION GAS CAN BE REMOVED</i> . <ul style="list-style-type: none"> When the calibration is complete, the status in the CO₂ Calibration control panel displays: <i>CALIBRATION DONE-OK</i> The calibration date will be updated upon exiting the CO ₂ Test control panel.		<p>O O</p> <p>O O</p>

17.0 EtCO₂ Calibration Check

Equipment 5% CO₂ calibration gas cylinder with CO₂ sample line (kit available from Scott Medical Products, PN 4653ORF-BD)

Note: If you have previously run the CO₂ Calibration procedure, start at step 3.

	Do This...	Observe This...	Pass/Fail
17.1	On the Propaq unit, select Supervisor>Service>Diagnostic>CO₂>Calibration to enter the CO ₂ Calibration control panel.		
17.2	Connect the Propaq unit to the 5% CO ₂ calibration gas cylinder using the sample line included with the calibration kit.		
17.3	From the CO ₂ Calibration control panel, select Verify Calibration .		
17.4	Activate the calibration gas flow by pressing the top valve on the calibration gas canister.		
17.5	Continue to apply the calibration gas until the status in the CO ₂ Calibration control panel displays: <i>CALIBRATION GAS CAN BE REMOVED</i> .		O O
17.6	Verify that the unit displays: <i>VERIFICATION DONE - OK</i> .		O O
17.7	Verify that the measured gas reading is between 4.8 and 5.2 (Vol%).		O O
17.8	Exit out of calibration by pressing the Back arrow key (⬅) three times or pressing the Display/Home button (⏪).		

18.0 EtCO₂ Test

Equipment CO₂ sampling line airway adapter

	Do this...	Observe this...	Pass/Fail
18.1	On the Propaq unit, install the airway adapter set and sampling line in the connector at the side of the unit.		
18.2	Press the CO ₂ quick access key () to activate the CO ₂ trace.	The CO ₂ trace is on the display.	o o
18.3	On Propaq unit, gently blow into the airway adapter set while observing the display.	The CO ₂ waveform changes on the display.	o o

19.0 IBP Test

Tools Needed IBP Simulator (with accuracy better than +/- 1 mmHg), or equivalent

Setup Connect the test cables to IBP patient simulator.



	Do This...	Observe This...	Pass/Fail
19.1	Connect the IBP patient simulator to the Propaq P1 channel.		
19.2	Set the IBP patient simulator to 0 mmHg.		
19.3	On the Propaq unit, press > IBP.		
19.4	On the Propaq unit, Press > P1->0<-.	Display of 0/0(+/-2) in the P1 box at the bottom of the display (P1 is zeroed). The waveform for channel 1 is present.	O O O O
19.5	Exit the menu to see the waveform.		
19.6	Set the IBP patient simulator to 200 mmHg (or as close to 200 mmHg as your simulator allows).	Display of 200/200(+/-5) in the P1 box at the bottom of the display as xxx/yyy where yyy=diastolic (P1 diastolic pressure is 200 (+/-5).	O O
19.7	Repeat steps 1 through 5 of this procedure for P2 and P3 channels.		
19.8	Disconnect IBP cable.		

20.0 NIBP Calibration Check

Equipment NIBP Simulator, dual lumen hose w/ NIBP test fixture cuff (9100-3072-TF) or equivalent

Note: If ECG simulator is connected to the device, either disconnect ECG simulator or disable the Smart Cuff feature in the Supervisor Menu.

Setup Attached the hose connected to the T-fitting of the NIBP test fixture cuff to the pressure port of the NIBP simulator. Set simulator to Static Pressure.



	Do This...	Observe This...	Pass/Fail
20.1	Turn on the Propaq unit. Note: If the unit is in AED mode, press the Manual quick access key to go into manual mode.		
20.2	Connect a dual lumen hose from the NIBP simulator to the NIBP port of the Propaq.		
20.3	On the Propaq unit, do the following to enter the NIBP Test control panel: <ul style="list-style-type: none"> Press the More () then the Setup () quick access keys. Use the navigation keys to select Supervisor>Service>Device Tests>NIBP Test. Note: You need a supervisor passcode to enter the Supervisor menu.		
20.4	From the Propaq NIBP Test control panel, use the navigation keys to select: <ul style="list-style-type: none"> Close Valve Turn Pump On 		
20.5	Monitor the pressure reported by the external pressure standard.		
20.6	Once the pressure reaches the target pressure of 50 +/- 5 mmHg, use the navigation keys to select Turn Pump Off .		
20.7	Allow the system to stabilize for at least 10 seconds.		
20.8	Verify that the primary transducer agrees with the reading on the NIBP simulator.	Reading should be within 3mmHg.	o o
20.9	Verify that the safety transducer agrees with the reading on the NIBP simulator.	Reading should be within 4mmHg.	o o

	Do This...	Observe This...	Pass/Fail
20.10	From the NIBP Test control panel, select Open Valve to release the pressure.		
20.11	From the Propaq NIBP Test control panel, use the navigation keys to select: <ul style="list-style-type: none"> • Close Valve • Turn Pump On 		
20.12	Monitor the pressure reported by the external pressure standard.		
20.13	Once the pressure reaches the target pressure of 150 +/- 5 mmHg, use the navigation keys to select Turn Pump Off .		
20.14	Allow the system to stabilize for at least 10 seconds.		
20.15	Verify that the primary transducer agrees with the reading on the NIBP simulator.	Reading should be within 3mmHg.	O O
20.16	Verify that the safety transducer agrees with the reading on the NIBP simulator.	Reading should be within 4mmHg.	O O
20.17	From the NIBP Test control panel, select Open Valve to release the pressure.		
20.18	From the Propaq NIBP Test control panel, use the navigation keys to select: <ul style="list-style-type: none"> • Close Valve • Turn Pump On 		
20.19	Monitor the pressure reported by the external pressure standard.		
20.20	Once the pressure reaches the target pressure of 250 +/- 5 mmHg, use the navigation keys to select Turn Pump Off .		
20.21	Allow the system to stabilize for at least 10 seconds.		
20.22	Verify that the primary transducer agrees with the reading on the NIBP simulator.	Reading should be within 3mmHg.	O O
20.23	Verify that the safety transducer agrees with the reading on the NIBP simulator.	Reading should be within 4mmHg.	O O
20.24	From the NIBP Test control panel, select Open Valve to release the pressure.		

	Do This...	Observe This...	Pass/Fail
20.25	Once complete, use the navigation keys to select Update NIBP Cal Check Date to save the date of the most recent calibration check. Note: This will reset the date. Nothing displays on the screen.		
20.26	Press  twice and select Diagnostic>NIBP>Calibration Info . Verify that the last NIBP Cal date is today's date.		
20.27	Exit out of the Supervisor menu.		

21.0 NIBP Leak Test

Equipment Dual lumen NIBP hose, stop watch, NIBP simulator

	Do This...	Observe This...	Pass/Fail
21.1	Turn on the Propaq unit. Note: If the unit is in AED mode, press the Manual quick access key to go into manual mode.		
21.2	Connect a dual lumen hose from the NIBP simulator to the NIBP port of the Propaq.		
21.3	On the Propaq unit, do the following to enter the NIBP Test control panel: <ul style="list-style-type: none"> • Press the More () then the Setup () quick access keys. • Use the navigation keys to select Supervisor>Service>Device Tests>NIBP Test. Note: You need a supervisor passcode to enter the Supervisor menu.		
21.4	From the Propaq NIBP Test control panel, use the navigation keys to select: <ul style="list-style-type: none"> • Close Valve • Turn Pump On 		
21.5	Monitor the pressure reported by the external pressure standard.		
21.6	Once the pressure reaches the target pressure of 250 +/- 5 mmHg, use the navigation keys to select Turn Pump Off .		
21.7	Allow the system to stabilize for at least 10 seconds.		
21.8	Select Mark P1 to mark the starting pressure. Wait 15 seconds, then select Mark P2 .		
21.9	From the NIBP Test control panel, select Open Valve to release the pressure.		
21.10	Calculate the leak rate: $L = P1 - P2$.	Reading should be ≤ 5 mmHg.	O O
21.11	From the NIBP Test control panel, select Clear .		

22.0 Deflation Test

Equipment Dual lumen NIBP hose, stop watch, NIBP simulator

	Do This...	Observe This...	Pass/Fail
22.1	From the Propaq NIBP Test control panel, use the navigation keys to select: <ul style="list-style-type: none"> • Close Valve • Turn Pump On 		
22.2	Monitor the pressure reported by the NIBP Test control panel or the external pressure standard, and select Turn Pump Off as soon as the pressure reaches the target pressure of 265 +/- 5 mmHg.		
22.3	Allow the system to stabilize for 5 seconds.		
22.4	Use the navigation keys to select Open Valve and immediately start the timer.		
22.5	Stop the timer as soon as pressure drops below 15 mmHg.	The pressure should drop within 10 seconds.	○ ○

23.0 Inflation Test

Equipment Dual lumen NIBP hose, stop watch, NIBP simulator

	Do This...	Observe This...	Pass/Fail
23.1	Verify that the pressure reported by the NIBP Test control panel or the external pressure standard system is less than 5 mmHg.		
23.2	From the NIBP Test panel, use the navigation keys to select Close Valve .		
23.3	Select Turn Pump On and immediately start the timer.		
23.4	Stop the timer as soon as pressure exceeds 210 mmHg.	Verify the time is less than 7 seconds.	O O
23.5	Select Turn Pump Off , then Open Valve .		
23.6	Exit the Service Menu and turn off the unit.		

24.0 NIBP Test

The primary purpose of an NIBP simulator is to reproduce a pressure profile similar to a live patient to be used for testing repeatability and functionality of the system. There are many different NIBP simulators, and manufacturers use different methods to develop their algorithm, which can cause varying readings from different simulators. In order to test for repeatability, you should first establish the offset of your simulator. The offset is a value that is produced on the NIBP monitor that is shifted from the simulator's setting. This value must be established based on the a statistical sample of monitors and readings.

Note: Refer to Appendix B for information on simulators and settings that you may use to assess the performance of the NIBP module.

Equipment

Dual lumen NIBP hose, NIBP simulator

	Do This...	Observe This...	Pass/Fail
24.1	On the Propaq unit, ensure the patient mode is set to Adult.		
24.2	Set the simulator to the 80/50 simulator preset.		
24.3	Take a manual reading.	Confirm that the NIBP measurement reported is within +/- 10 mmHg of the expected simulator performance.	O O
24.4	Set the simulator to the 120/80 simulator preset.		
24.5	Take a manual reading.	Confirm that the NIBP measurement reported is within +/- 10 mmHg of the expected simulator performance.	O O
24.6	Set the simulator to the 200/150 simulator preset.		
24.7	Take a manual reading.	Confirm that the NIBP measurement reported is within +/- 10 mmHg of the expected simulator performance.	O O
24.8	Disconnect hose.		

25.0 Temperature Test

Equipment IBP Temperature Simulator (or equivalent)





	Do this...	Observe This...	Pass/Fail
25.1	Connect the temperature simulator to the Propaq T1 channel.		
25.2	On the IBP Temp Simulator, Select 98.6 Degree F (36 Degree C) or a setting as close as possible as your simulator allows.	The displayed temperature value is within 1.0 F or 0.5 C of the simulator setting.	O O
25.3	Repeat steps 1 and 2 of this procedure for the T2 channel.		
25.4	Disconnect cable.		







26.0 Wi-Fi Test (Optional)

Equipment Dual-Band Router (2.4GHz and 5.0GHz)

Setup Set the router network name for each of the frequency bands.

- SSID= (your network name, i.e. WATS24, WATS50)
- Authentication= (your authentication mode, i.e. WPA-PSK, WPA2-PSK, Enterprise)
- Security Key= (enter your security key, i.e. 123456789)

	Do This...	Observe This...	Pass/Fail
26.1	Turn on the Propaq unit.	Verify that the amber wireless icon appears at the top of the display screen within one minute.	O O
26.2	<p>On the Propaq unit, do the following to test at 2.4GHz:</p> <ul style="list-style-type: none"> • Press the More () then the Setup () quick access keys. • Use the navigation keys to select Supervisor>Communications. • Use the navigation keys to enable Wi-Fi, then select Configure. • Highlight Add, then in the Add AP Profile window, select DHCP setting, and enter the desired settings for Profile Name (i.e. Test24), SSID (i.e. WATS24), Authentication, and Security Key. • Press the Display/Home () key to exit the menu. 		O O
26.3	<p>On the main display screen, do the following:</p> <ul style="list-style-type: none"> • Use the Display/Home () key and then the navigation keys to highlight the wireless icon. • Use the navigation keys to highlight Wi-Fi Access Point and select the profile name you created in step 2. 	Verify that the Access Point name is in the Selected Access Point field.	O O
26.4	Press () to exit the menu.	Verify that the wireless icon turns green.	O O

	Do This...	Observe This...	Pass/Fail
26.5	<p>On the Propaq unit, do the following to test at 5.0GHz:</p> <ul style="list-style-type: none"> • Press the More () then the Setup () quick access keys. • Use the navigation keys to select Supervisor>Communications. • Use the navigation keys to enable Wi-Fi, then select Configure. • Highlight Add, then in the Add AP Profile window, select DHCP setting, and enter the desired settings for Profile Name (i.e. Test50), SSID (i.e. WATS50), Authentication, and Security Key. • Press the Display/Home () key to exit the menu. 		0 0
26.6	<p>On the main display screen, do the following:</p> <ul style="list-style-type: none"> • Use the Display/Home () key and then the navigation keys to highlight the wireless icon. • Use the navigation keys to highlight Wi-Fi Access Point and select the profile name you created in step 2. 	Verify that the Access Point name is in the Selected Access Point field.	0 0
26.7	Press  to exit the menu.	Verify that the wireless icon turns green.	0 0
26.8	<p>On the main display screen, do the following:</p> <ul style="list-style-type: none"> • Press the More () then the Setup () quick access keys. • Use the navigation keys to select Supervisor>Communications. • Use the navigation keys to enable Wi-Fi, then select Configure. • Highlight the <i>Access Point Names</i> from step 2 and step 5, then select Delete. 	Verify that the wireless icon changes to amber.	0 0
26.9	Turn off the unit.		

Chapter 2

Troubleshooting

Overview

This chapter contains a list of error messages that users may see if the unit is not operating properly.

If the errors you encounter are not listed below, call ZOLL Medical Corporation's Technical Service Department for further assistance. (See "Technical Service" on page 3 for contact information.)

Propaq MD Error Messages

The following is a list of the Propaq MD error messages that may appear on your display. The "Technical Action" column describes what you as a technician can do to correct the situation.

Error Message	Explanation	Technical Action
ALARM SILENCE SHORT	Alarm Silence/Reset key is stuck.	Replace the front panel.
BLUETOOTH PHONE UNAVAILABLE	The Propaq MD unit was unable to establish a Wide Area Network connection. None of the Bluetooth phones paired with the device were detected.	<p>To correct the problem, verify the following:</p> <ul style="list-style-type: none"> • The Bluetooth device is paired with the Propaq MD unit. • The phone is on and near enough to the device to permit communication. • The phone is configured to allow data connection requests (if the phone has such a configuration setting).
CELLULAR CONNECT FAILURE	The Propaq MD unit was unable to establish a Wide Area Network connection. A cellular modem or Bluetooth cellular phone connection was attempted, but failed.	<p>To correct the problem, verify the following:</p> <ul style="list-style-type: none"> • The cellular provider information, particularly the call number, is correctly configured. • The cellular device has an active plan. • There is adequate cellular network signal coverage in the area. • (For phones) The phone is configured to allow data connection requests (if the phone has such a configuration setting). • (For modems) The cellular modem is a supported device and is securely connected to the Propaq MD unit. <p>If all the configurations are correct, retry the operation.</p>

Error Message	Explanation	Technical Action
CHECK COMM CONFIGURATION	A configuration error prevented successful communication.	To correct the problem, verify the following: <ul style="list-style-type: none"> • The reports configuration contains valid values for the Server, Port, Customer ID, and Password fields. • (Cellular modem) You are using a valid cell provider configuration (including call number) and the provider name is specified as the USB cell modem provider. • (Bluetooth DUN phone) A valid cell provider configuration (including call number) is present and the provider name is associated with the DUN phone pairing.
CO2 BAROMETRIC OUT OF RANGE	Altitude is too high for module.	Bring device into specified altitude range. If problem persists, replace the CO ₂ module.
CO2 CAL FAILURE	Calibration failed.	Retry calibration or continue with old calibration. Replace the CO ₂ module.
CO2 CAL REMINDER	Calibration reminder.	Calibrate the CO ₂ module soon.
CO2 CAL REQUIRED	Calibration due.	Calibrate the CO ₂ module.
CO2 CHECK FLOW	Exhaust port blocked.	Check for exhaust port occlusion. If problem persists, replace the CO ₂ module.
CO2 COM ERROR CODE	Communication failure.	Check communication cables. If problem persists, replace the CO ₂ module.
CO2 DEVICE FAILURE	Malfunction or device failure.	Replace the CO ₂ module.

Error Message	Explanation	Technical Action
CO2 GAS INPUT OCCLUSION	CO ₂ inlet blocked.	Replace FilterLine®. If problem persists, check for CO ₂ inlet occlusion. If problem still persists, replace the CO ₂ module.
CO2 MAINTENANCE REMINDER	Periodic maintenance reminder.	Replace CO ₂ module soon.
CO2 MAINTENANCE REQUIRED	Periodic Maintenance due.	Replace CO ₂ module.
CO2 NO FILTERLINE	No filterline is detected.	If FilterLine is connected and problem persists, replace FilterLine. If problem still persists, replace the CO ₂ module.
DEFIB CAP LEAKAGE	Capacitor bank cannot hold a charge.	Replace the capacitor bank module.
DEFIB CHARGE ERROR	Over voltage was detected.	If problem persists, replace the defibrillator board module.
DEFIB CHARGE TIMEOUT FAIL	The battery did not produce enough current to charge capacitor.	Charge the battery. If voltages are okay (from battery and aux), replace the defibrillator board module.
DEFIB DEVICE FAILURE	One of the following issues occurred: <ul style="list-style-type: none"> • Device could not charge up the self-test energy. • Discharge circuit failed to discharge voltage within specified time duration. • Device failed to deliver correct self-test energy. 	Check communication cables. If problem persists, replace defibrillator board module.
DEFIB DISCHARGE TEMP	Device is in a hot environment or the discharge circuit is always on.	Move device to cooler area. If problem persists, replace the defib board module.
DEFIB FATAL CHARGE ERROR	Charging error.	Replace the defibrillator board module.

Error Message	Explanation	Technical Action
DEFIB FIRE FAILURE	High impedance or low impedance (short).	Replace pads. If problem persists, check internal connections. If problem still persists, replace the defibrillator board module.
DEFIB LOW BATTERY	Battery is too low to charge defibrillator.	Charge the battery. Check battery contacts and clean if necessary.
DEFIB NO ENERGY DELIVERED	High impedance. No defib energy was delivered.	Replace pads. If problem persists, check internal connections. If problem still persists, replace the defibrillator board module.
DEFIB PACER DEVICE FAILURE	One of the following issues occurred: <ul style="list-style-type: none"> • Error was detected on the defib/pacer board. • Interface self-test communication failed. • Pacer interface self-test failed. • Communication with pacer hardware failed after startup. 	Check communication cables. If problem persists, replace the defibrillator board module.
DEFIB PHASE FAILURE	Phase I or phase II waveform dropout.	Replace the defibrillator board module.
DEFIB USING DEFAULT CALIBRATION	Calibration data lost.	Replace the defibrillator board module.
ECG DEVICE FAILURE	ECG software detected a problem with the ECG data that is most likely a hardware issue.	Replace the main board.
FP DEFIB CHARGE SHORT	Keys are stuck.	Replace the front panel.
FP DEFIB ENERGY DOWN SHORT	Defib energy Select Down (Decrease) key is stuck.	Replace the front panel.
FP DEFIB ENERGY UP SHORT	Defib energy Select Up (Increase) key is stuck.	Replace the front panel.
FP DEFIB FIRE SHORT	A key or a front panel button is stuck.	Replace the front panel.

Error Message	Explanation	Technical Action
HW SHUTDOWN	Voltage threshold exceeded the minimum working threshold of the device. There is no warning.	Charge the battery.
IBP DEVICE FAILURE	IBP software detected a problem with the IBP data that is most likely a hardware issue.	Replace the main board.
IBP PROBE1/PROBE2/ PROBE3 SHORTED	An A/D value was detected that indicated the probe was shorted.	Replace the problematic IBP probe. If the problem persists, replace the right side panel.
IBP PROBE1/PROBE2/ PROBE3 CIRCUIT FAILURE	An unsupported probe was inserted or there is a circuit problem.	Unplug the problematic probe, power cycle. If problem persists, replace main board.
NAMESERVICE FAILURE	The reports server hostname could not be resolved via DNS.	<p>To correct the problem, verify the following:</p> <ul style="list-style-type: none"> • The server DNS name is entered correctly and completely in the reports configuration. • The DNS server(s) are correctly configured (if using a Wi-Fi profile where static IP information was configured). • The DHCP server on the Wi-Fi network provides valid and correct DNS information in its response (if using a Wi-Fi profile with DHCP). <p>If using any form of cellular connectivity, retry the operation.</p>
NAV PAD DOWN SHORT	Down/Counterclockwise Navigation key is stuck.	Replace the front panel.
NAV PAD SELECT SHORT	Select key is stuck.	Replace the front panel.
NAV PAD UP SHORT	Up/Clockwise Navigation key is stuck.	Replace the front panel.

Error Message	Explanation	Technical Action
NIBP AIR LEAK	Major air leak or could not reach target pressure.	<p>Attempt to identify problems with the hose and/or cuff by doing the following:</p> <ul style="list-style-type: none"> • Check the hose connection to the device. Make sure that the hose is tightly screwed onto the NIBP connector. • Ensure that the cuff is appropriately wrapped and is not too loose. • Inspect the cuff and hose for leaks. Inspect the O-ring on the NIBP hose connector. Consider replacing the cuff and/or hose. <p>If the problem persists, perform the following procedure: "NIBP Leak Test" on page 40: Inspect internal NIBP tubing for leaks.</p>
NIBP ARTIFACT	Unable to determine blood pressure. Check connections; restrict patient movement.	Attempt to identify and eliminate the source of artifact. If problem persists, replace the NIBP module.
NIBP CALIBRATION CHECK DUE	Annual calibration check is due.	Perform the "NIBP Calibration Check" on page 37.
NIBP COMMUNICATION FAILURE	There is a communication problem with the NIBP module.	Ensure that the J32 connection is secure. If error persists, replace the NIBP module.
NIBP EQUIPMENT CHECK	Device is unable to obtain a reading.	<p>Check the hose and cuff connections. If problem persists, perform one or more of the following procedures in Chapter 1:</p> <ul style="list-style-type: none"> • NIBP Leak Test • NIBP Deflation Test • NIBP Inflation Test

Error Message	Explanation	Technical Action
NIBP KINKED HOSE	The cuff inflation was too rapid. There may be kinked tubing or another air obstruction.	Check the external NIBP hose for kinks. If problem persists, check the routing of the NIBP tubing inside the device.
NIBP LOW VOLTAGE	Insufficient voltage is supplied to the NIBP module.	Check the module voltage in the NIBP Test screen. Inspect the unit or water ingress. If evidence of water ingress is found, allow the water to evaporate while periodically checking the module voltage. If problem persists, replace the NIBP module.
NIBP MAX PRESSURE EXCEEDED	Pressure limit exceeded.	If problem persists, do the following: <ul style="list-style-type: none"> • Check the calibration via the “NIBP Calibration Check” on page 37. • Check the routing of the NIBP tubing inside the device for kinks or obstructions. If the NIBP module is out of calibration, replace the NIBP module.
NIBP MONITORING FAILURE	One of the following issues occurred: <ul style="list-style-type: none"> • A failure was reported by the NIBP module. • The two transducers are not aligned. They are either not calibrated, there is a transducer failure, or there is a kinked tube. • A calibration problem was reported by the NIBP module. 	If problem persists, replace the NIBP module.
NIBP NEONATAL DETECTED	Device thinks a neonate cuff is connected. If no neonate cuff is connected, tubing may be damaged or kinked.	Verify that neonate cuff is not connected. If problem persists, check the routing of the NIBP tubing inside the device.

Error Message	Explanation	Technical Action
NIBP TEMP OUT OF RANGE	Module temperature is out of its specified operating range.	Move the device to a cooler or warmer environment.
NIBP WEAK PULSE	Too few pulses are detected during the reading attempt.	Tighten the cuff and ensure appropriate placement.
PACER CURRENT FAULT	Lack of pacer current.	Replace the defibrillator board module.
PACER DEVICE FAILURE	Generation of pacer pulse failed.	Replace the defibrillator board module.
PRINTER OFFLINE	Printer module is off-line.	If it remains off line, try checking the connectors or power to the printer. If problem persists, replace the printer module.
PRINTER OUT OF PAPER	If there is paper in the device, probably a paper sensor problem.	Replace the printer module.
PRINTER PLATEN OPEN	If printer door is closed, probably a problem with the micro switch.	Replace the printer module.
PS DEFIB CHARGE SHORT	One of the paddle set keys are stuck.	Replace the paddle set or MFC.
PS DEFIB ENERGY DOWN	Paddle set keys are stuck.	Replace the paddle set or MFC.
PS DEFIB ENERGY DOWN SHORT	Paddle set energy down select button is stuck.	Replace the paddles.
PS DEFIB ENERGY UP	Paddle set keys are stuck.	Replace the paddle set or MFC.
PS DEFIB FIRE SHORT	Paddle set keys are stuck.	Replace the paddle set or MFC.
PS DEFIB RECORDER SHORT	One of the paddle set keys are stuck.	Replace the paddle set or MFC.
QUICK ACCESS SW 1(to SW 7) SHORT	One of the quick access keys (key 1 to key 7) is stuck.	Replace the front panel.
SCREEN CYCLE SHORT	Display/home key is stuck.	Replace the front panel.

Error Message	Explanation	Technical Action
SERVER AUTHENTICATION FAILED	The reports server rejected the connection request from the Propaq MD device.	To correct the problem, verify the following: <ul style="list-style-type: none"> • The customer ID and password are correctly entered in the reports configuration. (The password is case sensitive.) • The reports configuration has the correct server hostname and port. • The communications processor (CP) software is up to date.
SERVER UNREACHABLE	Although a WAN connection was established, the reports server connection could not be established or the connection was lost during a transfer.	Retry the operation.
SERVICE ERROR <CODE>	While communicating with the remote server, there was an error.	Retry the operation.
SNAPSHOT SHORT	Snapshot key is stuck.	Replace the front panel.
SPO2 COM ERROR CODE	Communication error.	Check communication cables. If problem persists, replace the SpO ₂ module.
SPO2 DEVICE FAILURE	Communication failure or device malfunction.	Check the SpO ₂ communication cables. If problem persists, replace the SpO ₂ module.
SPO2 SENSOR FAILURE	Defective sensor or sensor error.	Replace the SpO ₂ sensor.
SPO2 UNKNOWN RECOVERY NUM	Recovery error.	Replace the SpO ₂ sensor.
SW SHUTDOWN WARNING	Indication that the battery has reached the software shutdown capacity.	Charge the battery.
TEMP1 (or TEMP2) CIRCUIT FAILURE	The software detected an out-of-range A/D converter.	Remove probe then power cycle. If problem persists, replace the main board.

Error Message	Explanation	Technical Action
TEMP DEVICE FAILURE	Temp software detected a problem with the temperature data that is most likely a hardware issue.	Replace the main board.
TEMP PROBE1 (or PROBE2) SHORTED	An A/D value was detected that indicated the probe was shorted.	Replace the temperature probe or adapter cable. If problem persists, replace the right side panel.
TRANSMISSION FAILED	The communication operation failed. This message displays until a new operation is started.	<p>To correct the problem, verify the following:</p> <ul style="list-style-type: none"> • Wireless communication is enabled on the Propaq MD unit. • The Wi-Fi settings are correct in the Communications setup menu. • The ZOLL server is configured correctly. • Your cellular device is configured correctly. • The Propaq MD unit is within range of the wireless server.
WAN CONNECTION UNAVAILABLE	The Propaq MD unit was unable to establish a WAN connection.	<p>To correct the problem, verify the following:</p> <ul style="list-style-type: none"> • Wireless communication is enabled on the Propaq MD unit. • The expected means of communication is enabled (for instance, if using a cell modem, make sure the USB cell modem is set to Enabled). • (Bluetooth) It is paired with the Propaq MD unit. • (Wi-Fi) The correct Wi-Fi access point profile is selected. • (Cellular modem) It is properly connected to the Propaq MD unit and that the USB icon on the display is illuminated.

(This page intentionally left blank.)

Chapter 3

Disassembly Procedures

Overview

This chapter provides instructions on how to disassemble and reassemble the Propaq MD unit, and includes the following sections:

- Required Equipment
- Safety Precautions
- Modules
- Handle Disassembly
- Printer Disassembly
- Main Unit Disassembly
- Front Enclosure Disassembly
- Display Disassembly
- NIBP and EtCO₂ Disassembly
- Monitor Board and SpO₂ Disassembly
- CP Carrier Disassembly
- Defibrillator Board and Capacitor Bank Disassembly
- AUX Power Connector Disassembly
- Dock Connector Disassembly

Required Equipment

- No. 1 Phillips screwdriver with torque capability
- No. 2 Phillips screwdriver with torque capability
- Wooden stick (Available from H.A. Stiles: 1-800-447-8537)
- Needle nose pliers
- 6 mm socket wrench
- 26 mm socket wrench

- Kapton tape
- 3M copper adhesive tape, or equivalent
- Large diagonal cutters

Safety Precautions

WARNING!

SHOCK HAZARD!



Caution

TAKE THE NECESSARY PRECAUTIONS TO GUARD AGAINST SHOCK OR INJURY BEFORE YOU CONDUCT DEFIBRILLATOR TESTS OR REPAIRS.

- Only properly trained technicians should service the unit.
- The unit can contain deadly voltages even if the unit is turned off.
- Make sure to discharge the unit before working with it.
- Make sure you take the necessary precautions when working with static sensitive units. For example, you must wear a conductive wrist strap (which touches your skin) connected to a grounding mat and to the earth ground. You must remove the wrist strap when you discharge high voltage or when you are working on energized equipment.

Modules

The Propaq MD unit contains the following ten (10) modules or assemblies:

- Printer
- Front Enclosure
- Display
- NIBP
- EtCO₂ (Oridion[®])
- Monitor Board
- Capacitor Bank
- Defibrillator Board
- SpO₂
- CP Carrier Module

These modules can be purchased as replacement parts from the ZOLL Technical Support Department. See Chapter 4, "Replacement Parts" for information on ordering replacement parts.

Removing the Handle



Tools Required

- #1 Phillips screwdriver with torque capability
- Wooden stick

Setup

- This procedure should be conducted on a static mat.
- Wear a wrist strap to ground during the procedure.

To reinstall the handle assembly, reverse the steps.

Handle Disassembly		
<p>1</p>	<p>Using a wooden stick, lift the screw covers off the handle in two locations.</p>	
<p>2</p>	<p>Remove four (4) screws (2 on each handle) and remove the handle.</p> <p>Note: During reassembly, torque screws to 8 in-lbs.</p>	

Removing the Printer Module

Tools Required

- #1 Phillips screwdriver with torque capability

Setup

- This procedure should be conducted on a static mat.
- Wear a wrist strap to ground during the procedure.

To reinstall the printer module, reverse the steps.

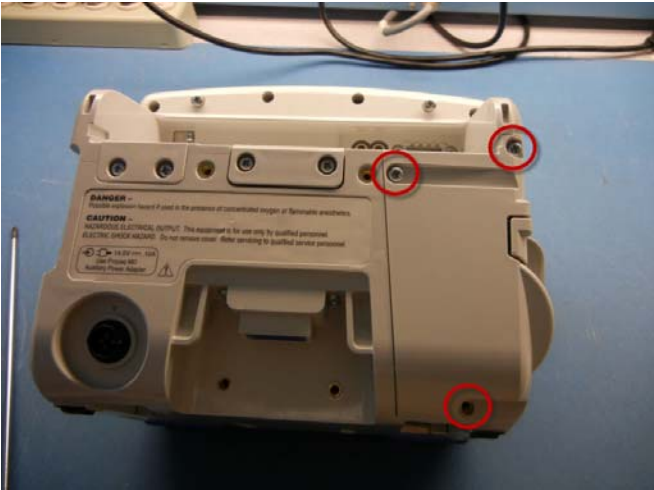
Printer Disassembly		
1	Place the unit on the mat in a horizontal position.	
2	Open the printer housing and remove the printer paper.	
3	Place the unit screen down and remove the three (3) screws outside the printer module in the illustrated areas. Note: During reassembly, torque screws to 6 in-lbs.	

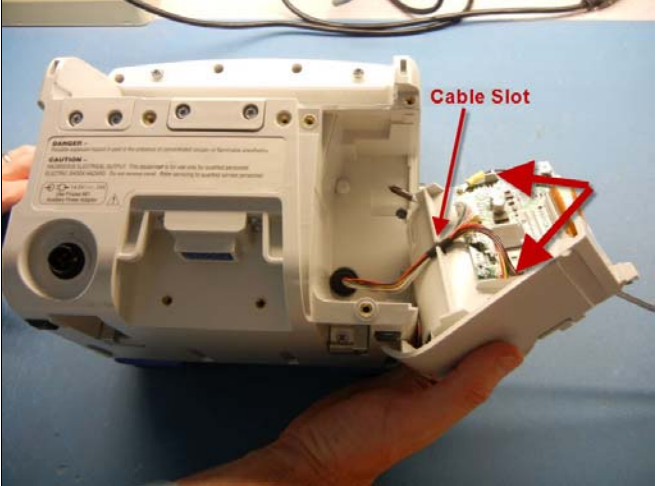
<p>4</p>	<p>Slowly slide the printer from the unit, being careful not to strain the cables.</p>	
<p>5</p>	<p>Disconnect the two 2 cable connectors from the printer module, and pull cables out of slot.</p>	

Disassembling the Main Unit

Tool Required

- # 1 Phillips screwdriver with torque capability
- Wooden stick
- Kapton tape



Setup

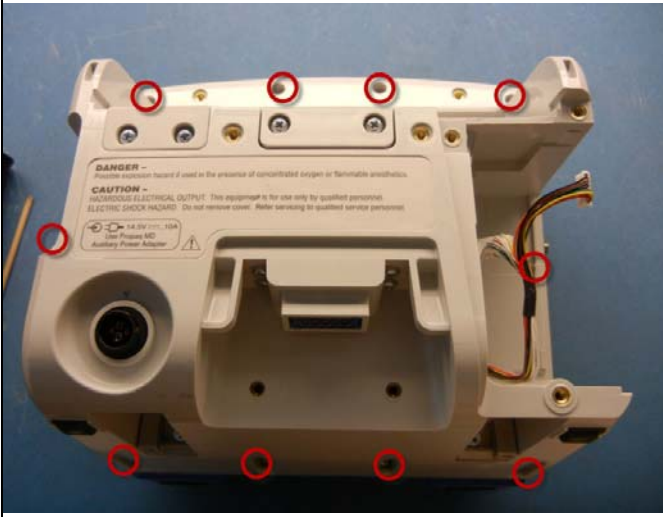
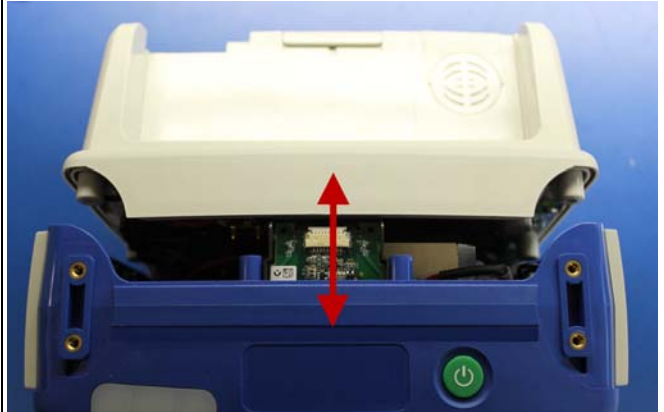

- This procedure should be conducted on a static mat.
- Wear a wrist strap to ground during the procedure.
- Complete these procedures in the following order before performing this procedure:
 1. “Removing the Handle” on page 61
 2. “Removing the Printer Module” on page 62

To reassemble the main unit, reverse the steps.

Main Unit Disassembly		
<p>1</p>	<p>Place tape on both sides of the unit. (This will temporary hold the sections of the unit together).</p>	
<p>2</p>	<p>Gently place unit screen so the display is facing down.</p>	

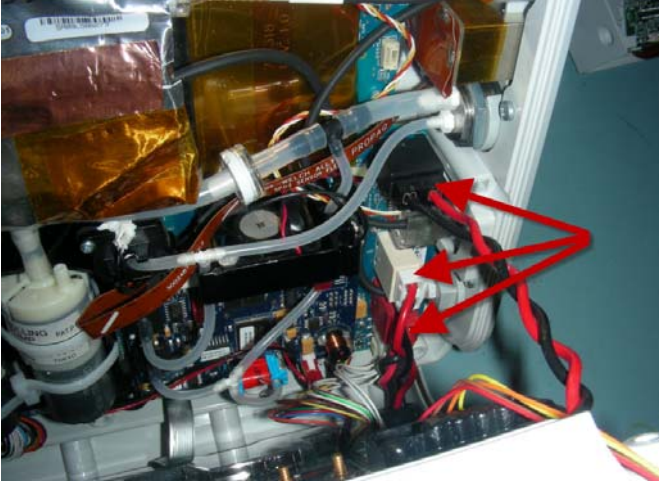
<p>3 Remove ten (10) screws: four (4) on the top, four (4) on the bottom, and two (2) in the middle in the illustrated areas. Take care to keep the two parts of the unit together.</p> <p>Note: During reassembly, torque screws to 6 in-lbs.</p>	 <p>A photograph showing the rear of a white plastic main unit. Ten screws are circled in red: four along the top edge, four along the bottom edge, and two in the center. The unit has a circular port on the left and a power button on the right. Text on the back includes 'DANGER - Possible explosion hazard if used in the presence of concentrated oxygen or flammable anesthetics', 'CAUTION - HIGH VOLTAGE ELECTRICAL OUTPUT. This equipment is for use only by qualified personnel. ELECTRIC SHOCK HAZARD. Do not remove cover. Refer servicing to qualified service personnel.', and 'User Program MD Auxiliary Power Adapter'.</p>
<p>4 While holding the two parts of the unit together, place the unit vertically on the mat (feet down).</p>	
<p>5 Separate the top part of the unit by creating a small gap, and remove any screws that are in the way.</p>	 <p>A photograph showing the top of the white plastic main unit. A red double-headed vertical arrow is positioned in the center, indicating the gap to be created between the top and bottom parts of the unit. The unit is resting on a blue base with a green power button.</p>

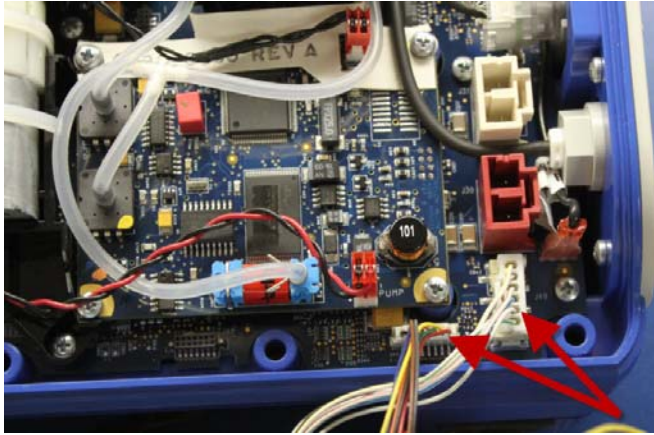
<p>6</p>	<p>Disconnect the battery communication cable (yellow, orange, brown, red) connector from the monitor board.</p>	
<p>7</p>	<p>Disconnect the monitor/defibrillator flex cable and MFC cable connectors from the monitor board.</p> <p>Note: Be careful to pull the connector straight out. Rocking the connector or disconnecting it at an angle may result in bent pins.</p>	
<p>8</p>	<p>Disconnect the three power cable connectors (battery (black), AUX (white), and defibrillator (red)).</p>	

<p>9</p>	<p>Press the tabs on either side of the two printer cables to disconnect them.</p>	
<p>10</p>	<p>Use a wooden stick to release the tabs on either side of brown flex connector between the dock connector and the monitor board.</p> <p>Note: Release one side at a time.</p>	
<p>11</p>	<p>Separate the two parts of the unit.</p>	

Removing the Front Enclosure Module

Tools Required



- #2 Phillips screwdriver with torque capability
- Wooden stick

Setup

- This procedure should be conducted on a static mat.
- Wear a wrist strap to ground during the procedure.
- Complete these procedures in the following order before performing this procedure:
 1. “Removing the Handle” on page 61
 2. “Removing the Printer Module” on page 62
 3. “Disassembling the Main Unit” on page 64

To reinstall the front enclosure module, reverse the steps.

Front Enclosure Disassembly		
1	Remove tape from both sides of the unit.	
2	Separate front enclosure assembly.	
3	Pivot top up with cables still connected.	

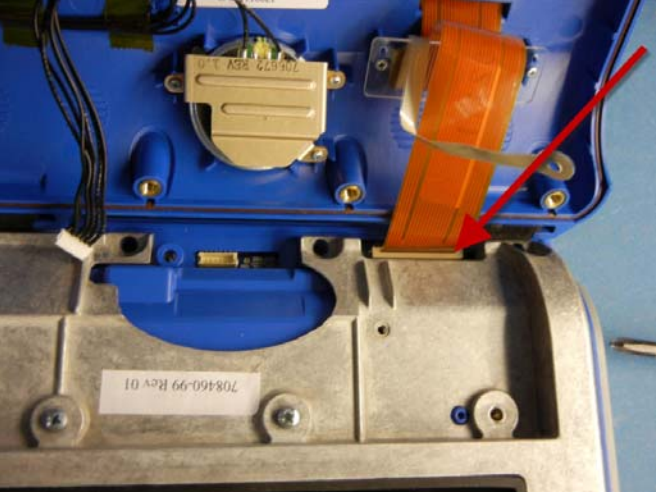
<p>4</p>	<p>Remove grounding screw as shown in the illustration.</p> <p>Note: During reassembly, torque screw to 6 in-lbs.</p>	
<p>5</p>	<p>Disconnect the front panel multi-wire power/speaker cable in the area illustrated.</p>	
<p>6</p>	<p>Remove the ZIF (Zero Insertion Force) flex cable using a wooden stick.</p>	

Removing the Display Module

Tools Required



- #1 Phillips screwdriver with torque capability
- 3M copper adhesive tape
- 6mm socket wrench
- Mid-Frame LCD Cable Routing Assembly Fixture, 9100-3028-AF (Optional)

Setup

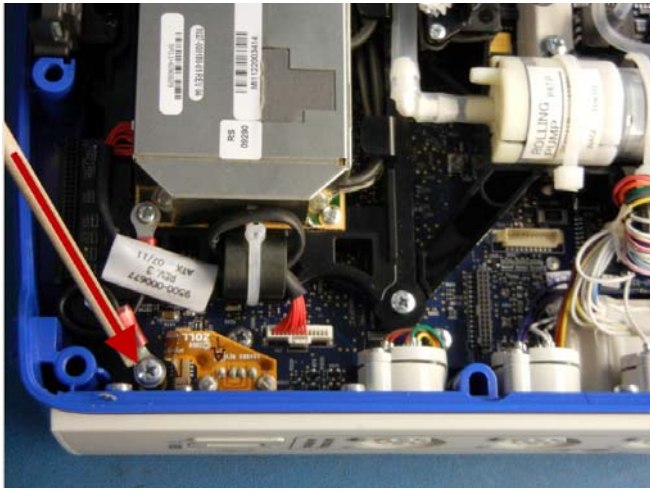

- This procedure should be conducted on a static mat.
- Wear a wrist strap to ground during the procedure.
- Complete these procedures in the following order before performing this procedure:
 1. “Removing the Handle” on page 61
 2. “Removing the Printer Module” on page 62
 3. “Disassembling the Main Unit” on page 64
 4. “Removing the Front Enclosure Module” on page 68

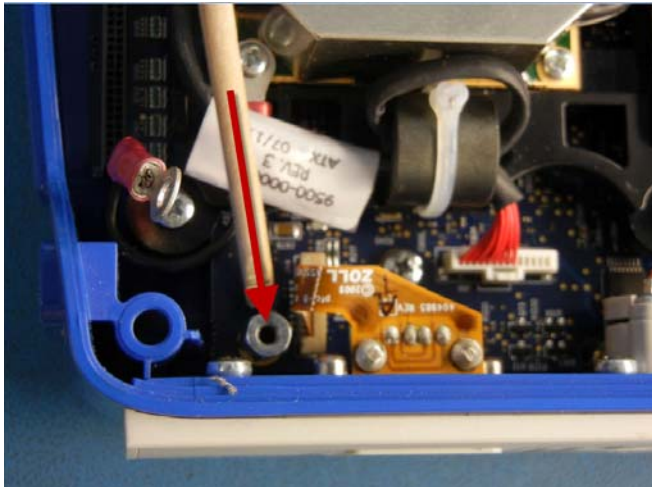
To reinstall the display module, reverse the steps.

Display Disassembly	
<p>1 Remove the grounding screw and washer for EtCO₂ in the area illustrated.</p>	

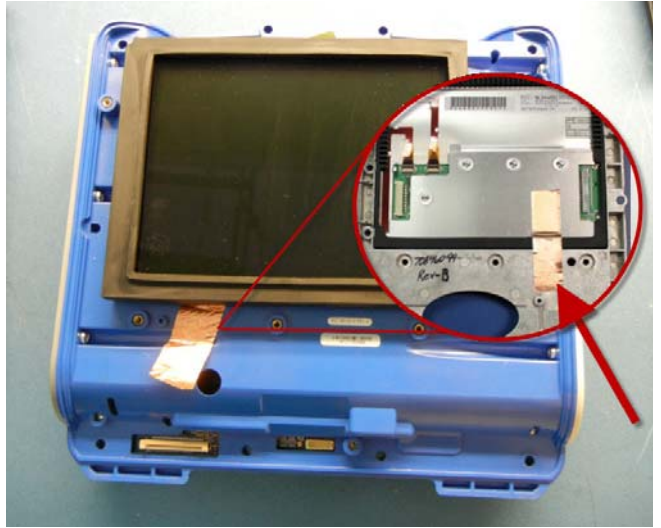
<p>2</p>	<p>Using the 6mm socket wrench, remove the hex standoff located underneath the screw you just removed.</p> <p>Note: During reassembly, torque to 6 in-lbs.</p>	
<p>3</p>	<p>Place the back of the unit down on the mat so that the display screen is facing up.</p>	
<p>4</p>	<p>Remove the six (6) screws from the front of the casting in the areas illustrated.</p> <p>Note: During reassembly, torque screws to 6 in-lbs.</p>	

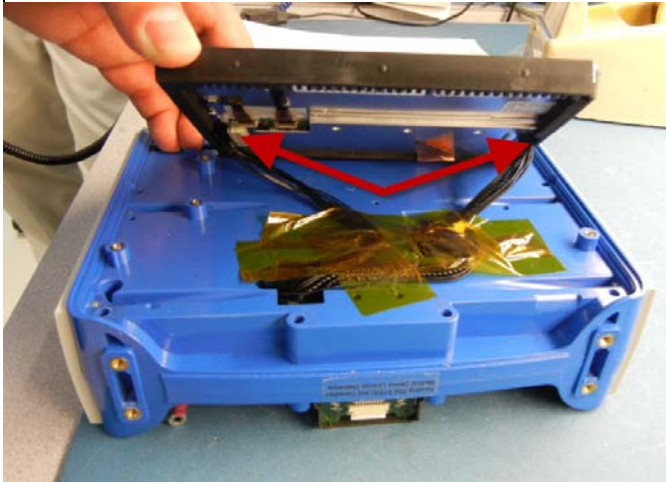
<p>5</p>	<p>Lift the casting up while pushing down on the rubber boot that runs around the edge of the LCD screen.</p>	
<p>6</p>	<p>Remove the copper tape from the casting.</p> <p>Note: During reassembly, apply new copper tape for grounding.</p> <p>If casting is being replaced, scuff the underside of the casting where the tape is being applied, with a fiberglass brush.</p> <p>Wipe area with lint free wipe and alcohol.</p>	

<p>7 Disconnect the LCD display cable connectors from the back of the LCD screen to release it.</p> <p>Note: During reassembly, make sure that when taping the LED cable assembly to the spider frame, that the cable is clear from the display frame as shown. (The use mid-frame assembly fixture 9100-3028-AF is optional.)</p>	 
---	--

Removing the EtCO₂ and NIBP Modules

Tool Required

- # 1 Phillips screwdriver with torque capability
- Wooden stick
- Large diagonal cutters
- Metal Pick

Setup

- This procedure should be conducted on a static mat.
- Wear a wrist strap to ground during the procedure.
- Complete these procedures in the following order before performing this procedure:
 1. “Removing the Handle” on page 61
 2. “Removing the Printer Module” on page 62
 3. “Disassembling the Main Unit” on page 64
 4. “Removing the Front Enclosure Module” on page 68

To assemble the EtCO₂ and/or NIBP modules, reverse the steps.

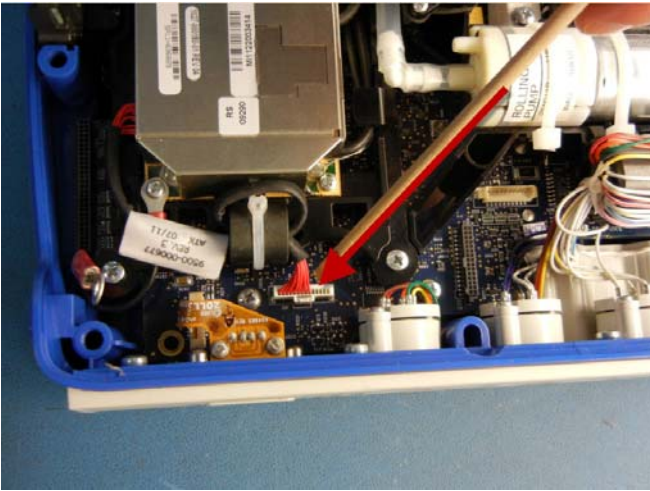
EtCO ₂ and/or NIBP Disassembly	
1	<p>Unplug the power connector by press on the tab and puling straight out.</p> 

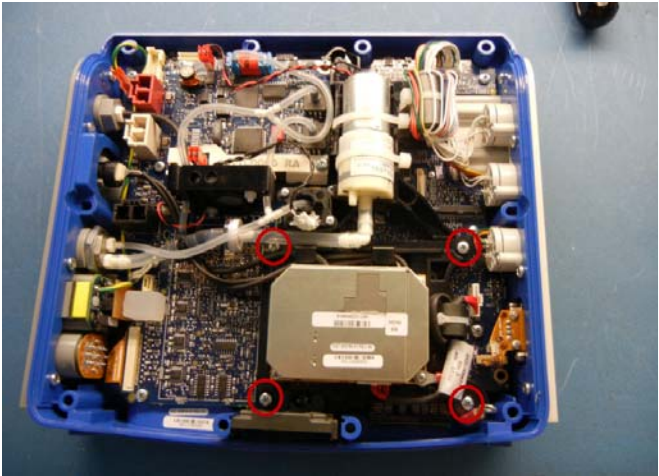
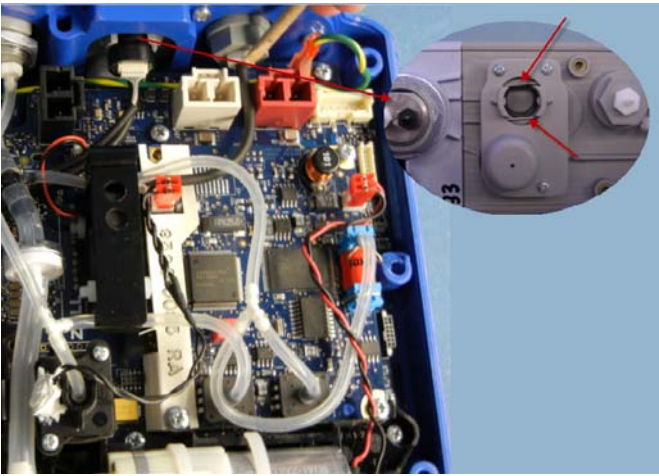
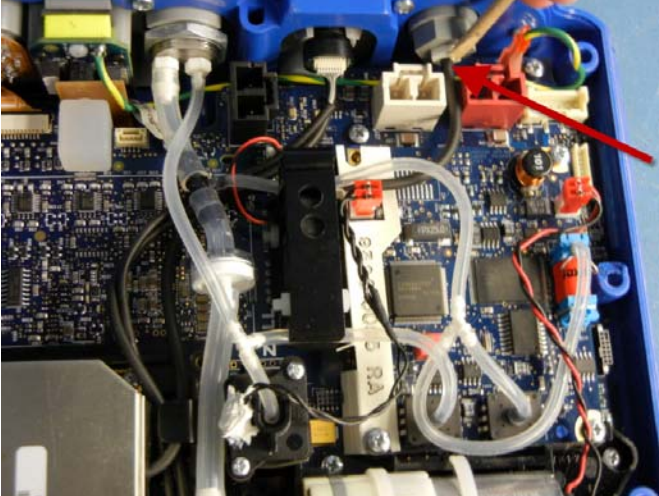
<p>2</p> <p>Remove four (4) screws around the EtCO₂ unit.</p> <p>Note: During reassembly, torque screws to 6 in-lbs.</p>	
<p>3</p> <p>Disconnect the EtCO₂ sensor from side panel by using a metal pick and releasing the clips on both sides.</p>	
<p>4</p> <p>Disconnect the exhaust tube connector from the air vent at area shown.</p>	

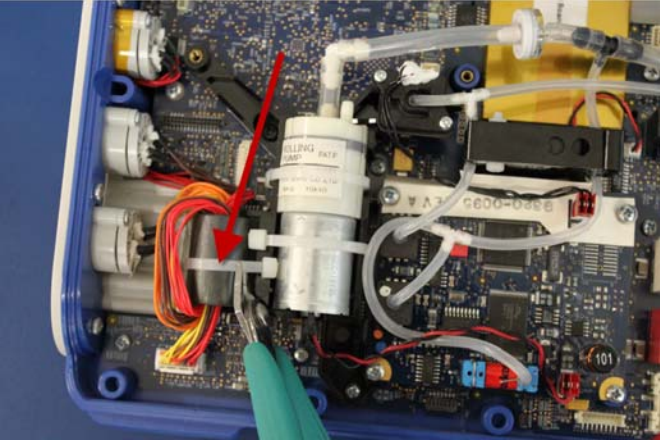
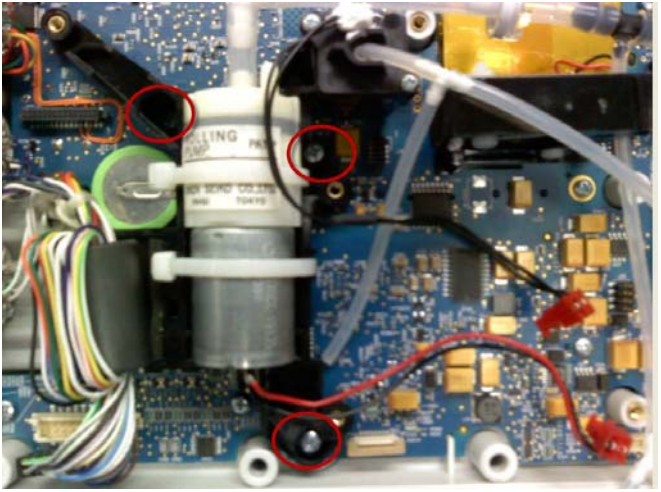
<p>5</p>	<p>Remove EtCO2 module by lifting assembly out. If necessary disconnect NIBP hoses to make it easier to pull connector through.</p>	
<p>6</p>	<p>Cut the tie wrap holding the ferrite bead.</p>	
<p>7</p>	<p>Remove three (3) screws from NIBP unit. Note: During reassembly, torque screws to 6 in-lbs.</p>	

Removing the Monitor Board and SpO₂ Modules

Tool Required

- # 1 Phillips screwdriver with torque capability
- Wooden stick

Setup

- This procedure should be conducted on a static mat.
- Wear a wrist strap to ground during the procedure.
- Complete these procedures in the following order before performing this procedure:
 1. “Removing the Handle” on page 61
 2. “Removing the Printer Module” on page 62
 3. “Disassembling the Main Unit” on page 64
 4. “Removing the Display Module” on page 70
 5. “Removing the EtCO₂ and NIBP Modules” on page 74

To reinstall the monitor board and/or SpO₂ modules, reverse the steps.

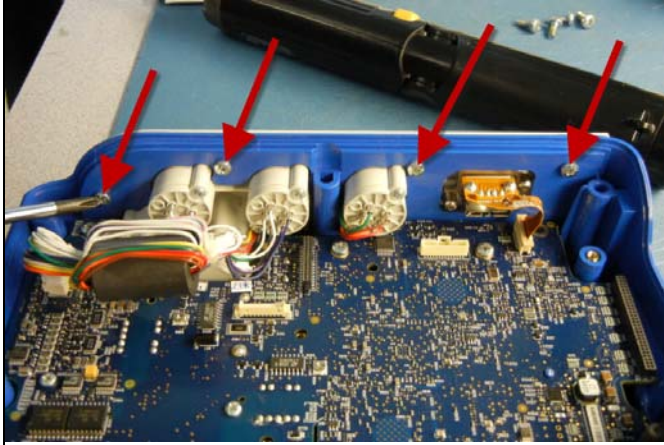
Monitor Board and/or SpO ₂ Disassembly	
<p>1 Remove 4 screws on the right side of the unit in the illustrated areas.</p> <p>Note: During reassembly, torque screws to 6 in-lbs.</p>	

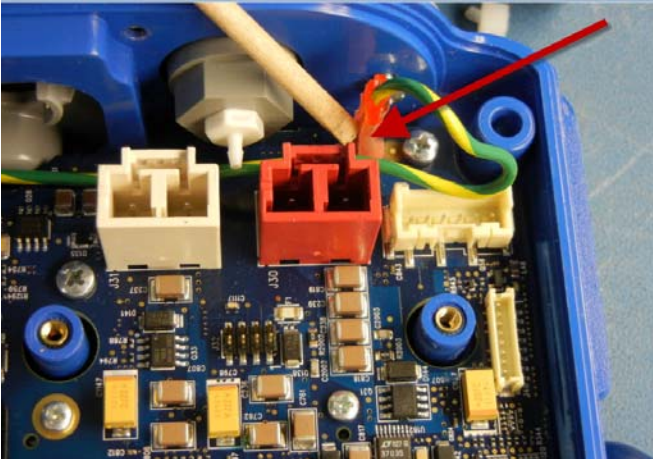
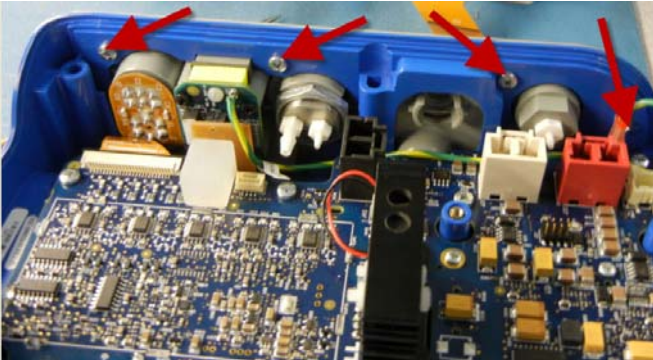
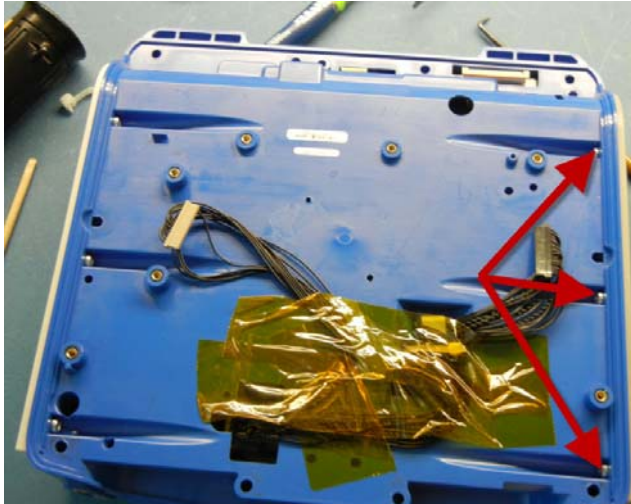
<p>2</p>	<p>Disconnect the SpO₂ ground cable.</p>	
<p>3</p>	<p>Remove 4 screws on the left side in the illustrated areas. Note: During reassembly, torque screws to 6 in-lbs.</p>	
<p>4</p>	<p>Turn the unit over.</p>	
<p>5</p>	<p>Remove 3 screws on the left side of the unit in the illustrated areas.</p>	
<p>6</p>	<p>Turn the unit over.</p>	

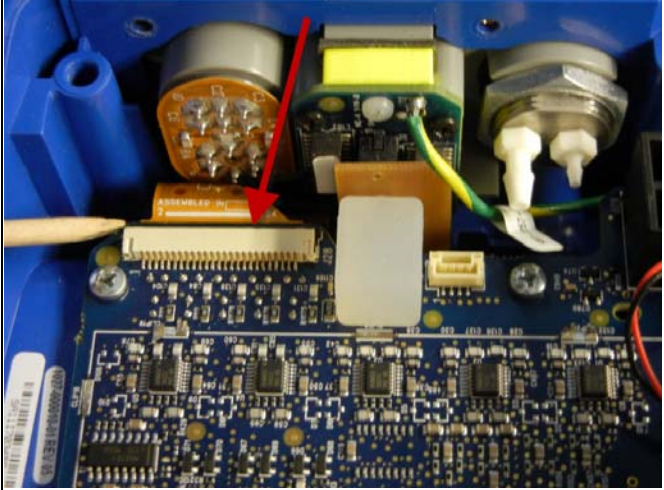
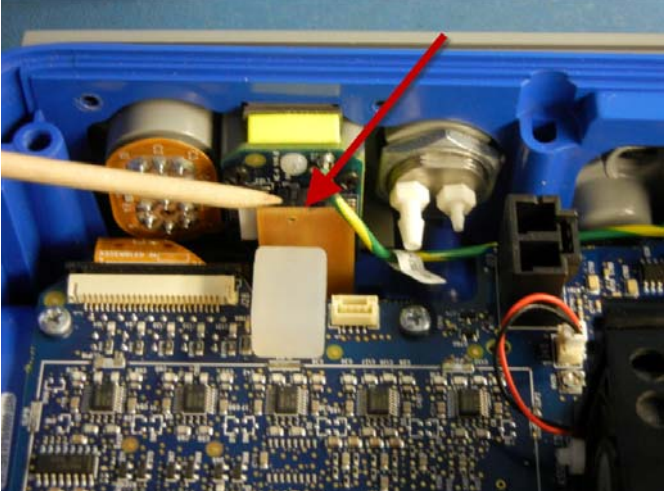
<p>7</p>	<p>Disconnect ECG flex cable ZIF connector from the left side.</p>	
<p>8</p>	<p>Disconnect the SpO₂ connector.</p>	
<p>9</p>	<p>Remove the left side of the unit.</p>	

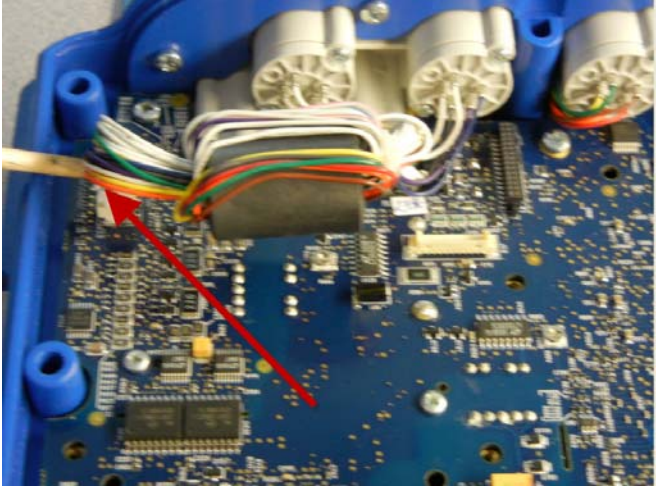
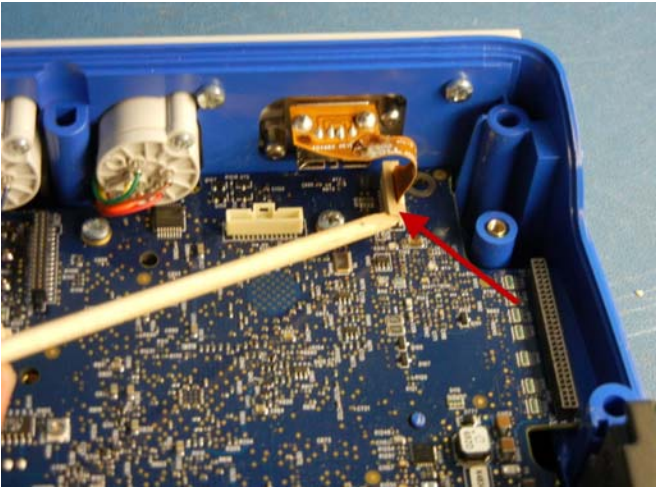
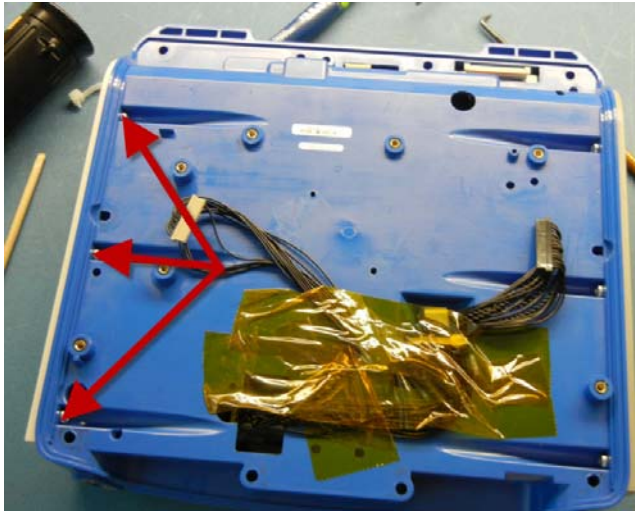
<p>10</p>	<p>Disconnect the IBP connector.</p>	 A close-up photograph of the blue monitor board. A bundle of multi-colored wires is connected to a connector on the board. A wooden stick is being used to lift the connector, and a red arrow points to the connection point.
<p>11</p>	<p>Disconnect the USB ZIF connector.</p>	 A close-up photograph of the monitor board. A USB ZIF connector is being lifted from the board with a wooden stick. A red arrow points to the connector.
<p>12</p>	<p>Turn the unit over.</p>	
<p>13</p>	<p>Remove the 3 screws on the right side of the unit in the illustrated areas.</p>	 A photograph of the back of the blue unit. Three screws on the right side are being removed, as indicated by three red arrows. A gold-colored component is visible in the center of the unit.

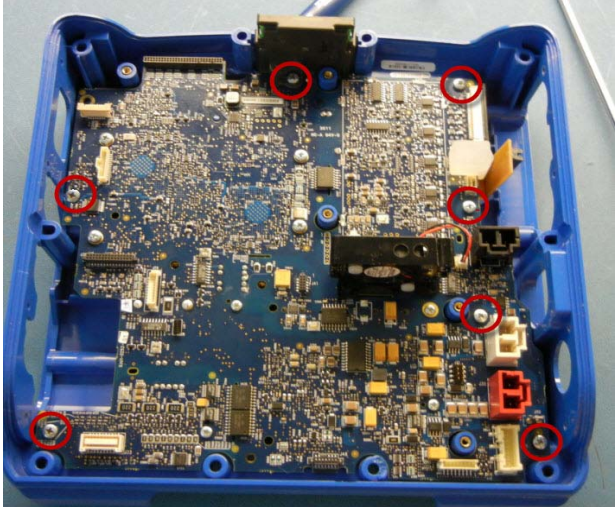
14	Turn the unit over.	
15	Remove the right side panel of the unit.	
16	Disconnect the LCD cable.	
17	Remove 7 screws securing monitor board, then lift board out.	

Removing the CP Carrier Module

Tools Required

- #1 Phillips screwdriver with torque capability

Setup

- This procedure should be conducted on a static mat.
- Wear a wrist strap to ground during the procedure.
- Complete these procedures in the following order before performing this procedure:
 1. “Removing the Handle” on page 61
 2. “Removing the Printer Module” on page 62
 3. “Disassembling the Main Unit” on page 64
 4. “Removing the Display Module” on page 70
 5. “Removing the EtCO2 and NIBP Modules” on page 74
 6. “Removing the Monitor Board and SpO2 Modules” on page 78

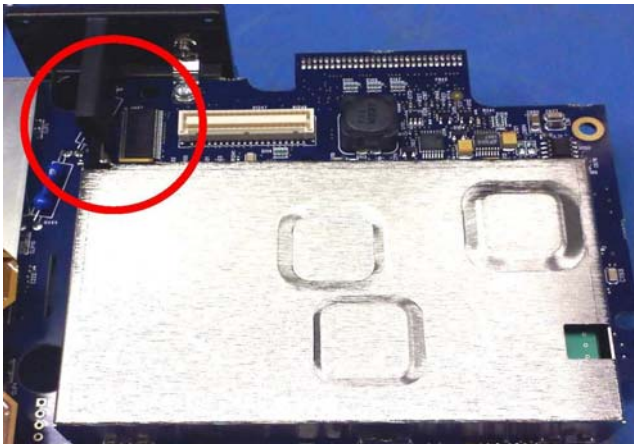
CP Module Disassembly	
<p>1 Remove the shield by pulling it upwards over the CP carrier board.</p> <p>Note: During reassembly, be sure to route antenna wires through slot (red circle) in the shield. Secure the shield to the board by aligning with slots on the board.</p>	

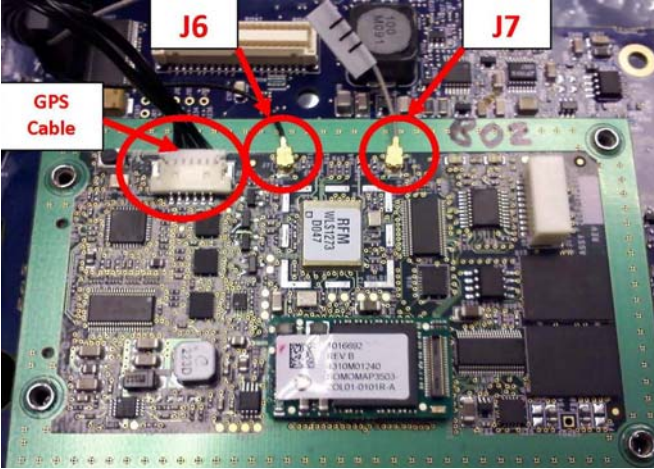
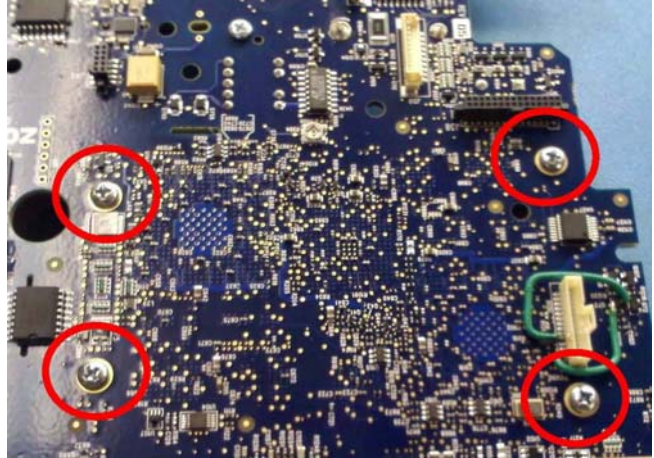
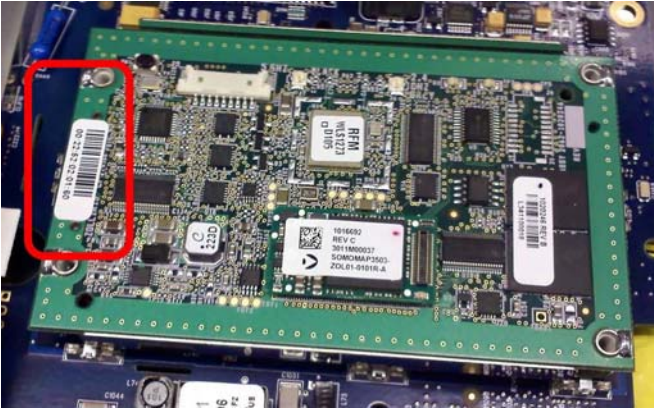
<p>2</p>	<p>Remove the 9-pin GPS and 2 antenna cables (gray cable J7 and black cable J6) from the CP carrier board.</p>	
<p>3</p>	<p>Turn board over, and remove the 4 screws securing the CP board to the monitor board.</p> <p>Note: During reassembly, torque screws to 6 in-lbs.</p>	
<p>4</p>	<p>Only lift the CP carrier board (not the metal heat spreader) upwards at location J60 on the monitor board.</p> <p>Note: During reassembly, align connectors on board.</p>	

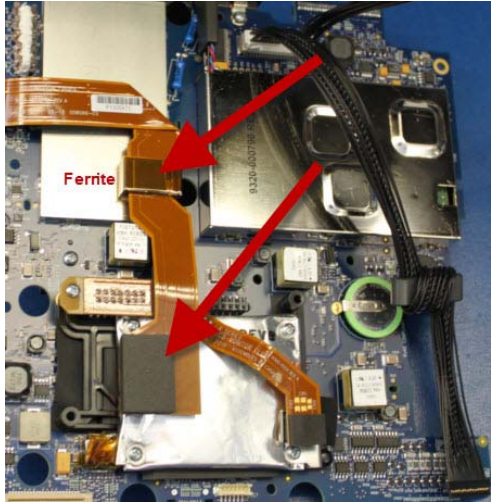
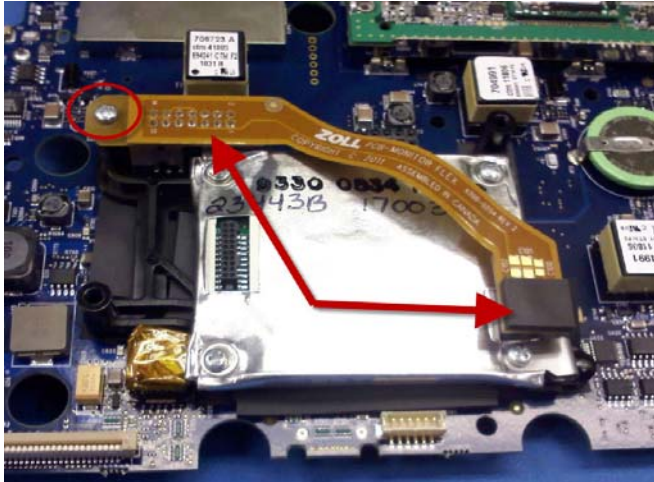
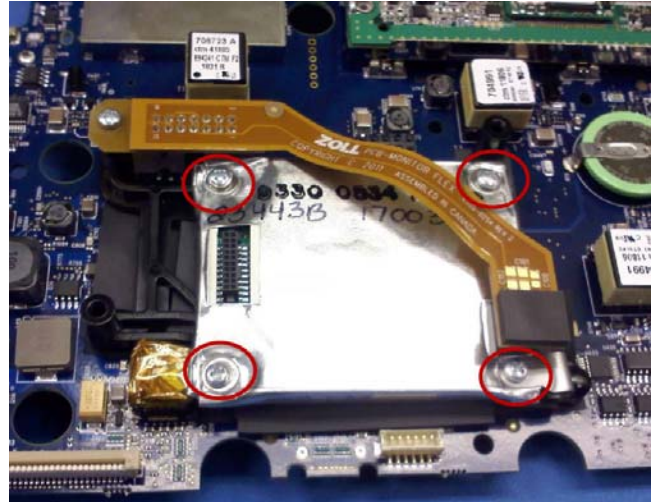
<p>5</p>	<p>Disconnect the top flex cable connectors from SPO₂ module, then remove cable and ferrite.</p>	
<p>6</p>	<p>Remove the screw from the flex cable, then disconnect flex cable from the connectors in two locations.</p> <p>Note: During reassembly, torque screws to 4 in-lbs.</p>	
<p>7</p>	<p>Remove 4 screws from the SpO₂ module and remove it.</p> <p>Note: During reassembly, torque screws to 4 in-lbs.</p>	

Removing the Defibrillator Boards and Capacitor Bank Modules

Tools Required

- #1 Phillips screwdriver with torque capability
- #2 Phillips screwdriver with torque capability
- 26 mm open end wrench
- Large diagonal cutters
- 5k Ohm, 25 watt, resistor

Setup

- This procedure should be conducted on a static mat.
- Wear a wrist strap to ground during the procedure.
- Complete these procedures in the following order before performing this procedure:
 1. “Removing the Handle” on page 61
 2. “Removing the Printer Module” on page 62
 3. “Disassembling the Main Unit” on page 64

To reinstall the defibrillator boards and/or capacitor bank modules, reverse the steps.

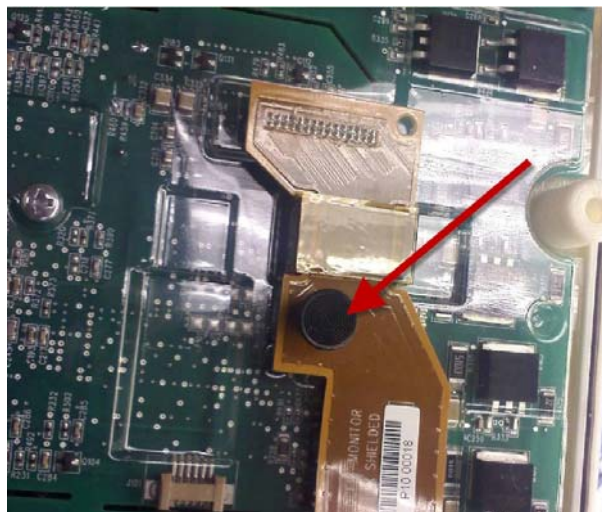

Defibrillator Boards and Capacitor Bank Disassembly	
1	Lay back end of separated unit down with opened side facing up.
2	Pull the black snap rivet straight out.

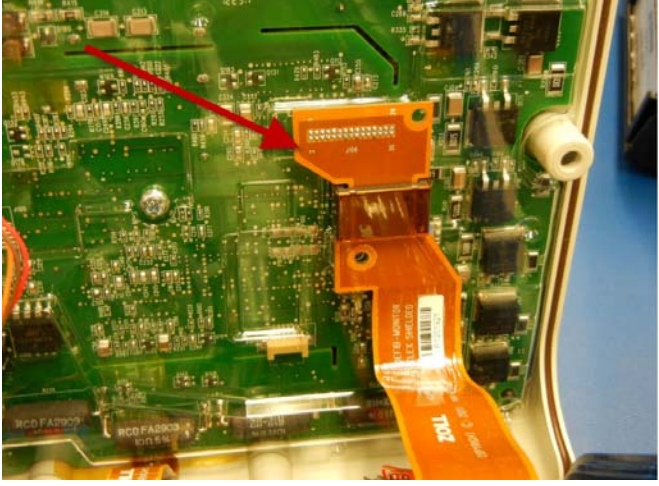
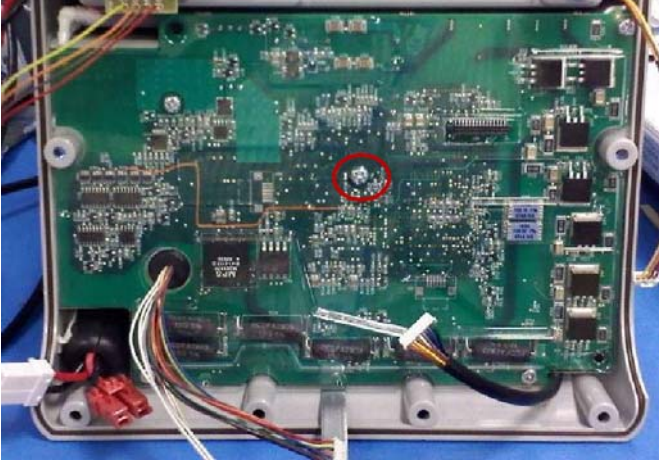



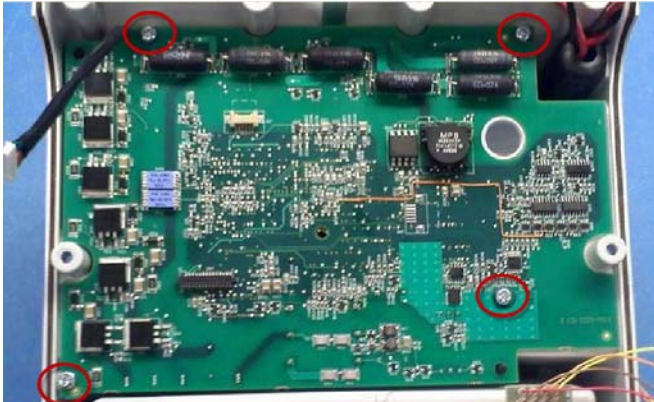

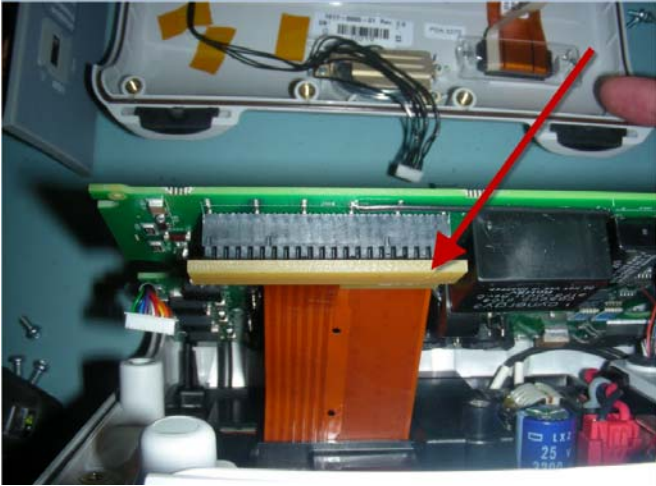
<p>3</p>	<p>Disconnect the defib-system flex cable from the processor board by pulling straight up from board.</p>	
<p>4</p>	<p>Remove screw in the middle of the plastic isolator (located on top of the processor board) in the area illustrated.</p> <p>Note: During reassembly, torque screw to 6 in-lbs.</p>	
<p>5</p>	<p>Remove the plastic isolator shield.</p>	

WARNING! This unit may contain lethal voltages. You **MUST** completely discharge the high voltage capacitor before removing from unit. **DO NOT SHORT THE TRERMINAL ENDS OF THE CAPACITOR.**

<p>6 Discharge the capacitor by bleeding out the excess voltage using a resistor with values of approximately 5k Ohms, (25 watts for 10-20 seconds). Counting from the right connect, apply the resistor across the second and forth via as shown in picture. Measure the voltage of the capacitor on the same two vias to verify that the capacitor is discharged.</p>	 A close-up photograph of a green printed circuit board (PCB) inside a device. Two red test leads are connected to two specific vias on the board. The leads are positioned to short the vias together, as described in the text. Various electronic components like capacitors and resistors are visible on the board.
<p>7 Remove the four (4) screws from the processor board in the areas illustrated.</p> <p><i>Note: During reassembly, torque screws to 6 in-lbs.</i></p>	 A wider photograph of the green PCB. Four screws are circled in red, indicating their locations for removal. The screws are located at the corners of the board: top-left, top-right, bottom-left, and bottom-right. The board is populated with various electronic components.

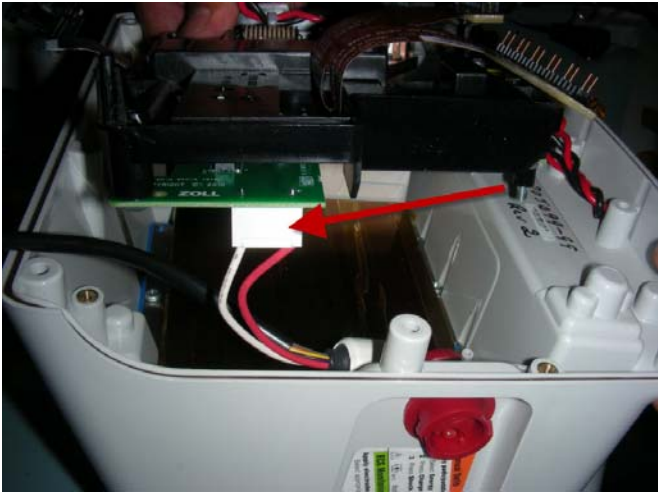
<p>8</p>	<p>Lift up the processor board and disconnect the brown flex cable (there are two connections).</p>	
<p>9</p>	<p>Lift out the processor board.</p>	
<p>10</p>	<p>Remove the black capacitor cable by pressing the tab to release.</p>	

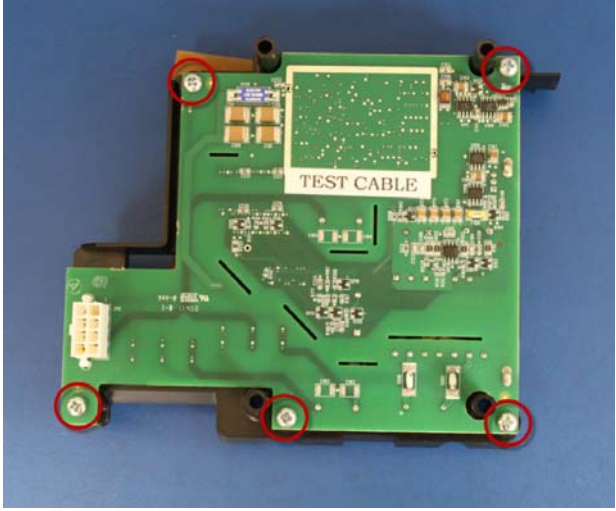
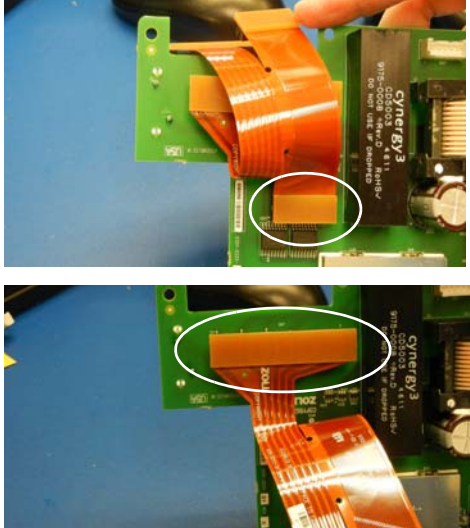
<p>11</p>	<p>Cut the tie wrap securing the Power Monitor to Pace cable (black and red coupled wire) and disconnect the cable (via the red connector) in illustrated area.</p>	
<p>12</p>	<p>Remove four (4) screws from the frame support in the areas illustrated.</p> <p>Note: During reassembly, torque screws to 6 in-lbs.</p>	
<p>13</p>	<p>Lift up on the ECG assembly and remove red and white MFE cable (via the white connector) from the ECG board. Remove ECG assembly.</p>	

<p>14</p>	<p>Remove the 5 screws securing the ECG board to bracket, and then separate the board from the bracket.</p> <p>Note: During reassembly, torque screws to 6 in-lbs.</p>	 <p>A photograph of a green printed circuit board (PCB) mounted on a black metal bracket. Five screws are circled in red, indicating they need to be removed. A white label on the board reads "TEST CABLE".</p>
<p>15</p>	<p>Remove the Bridge/Pace to ECG cable from the ECG board in the two areas illustrated.</p> <p>Note: During reassembly, match the designator on the flex cable and the ECG board.</p>	 <p>Two close-up photographs showing the removal of an orange flex cable from the ECG board. The top photo shows the cable being lifted from a connector, and the bottom photo shows the cable being fully detached. A white circle highlights the connection point in both images.</p>
<p>16</p>	<p>Remove two (2) screws securing the capacitor to housing, then lift capacitor out.</p> <p>Note: During reassembly, torque screws to 6 in-lbs.</p>	 <p>A photograph of a grey capacitor bank module housed in a grey plastic housing. Two screws at the bottom of the module are circled in red, indicating they need to be removed. A white label on the module contains the following text: "AEROVOX ENERGY DISCHARGE CAPACITOR 1000F 450V 5% 180000VDC NO PCB'S MADE IN USA DANGER THE HIGH VOLTAGE CHARGE STORED IN THIS CAPACITOR BANK MAY BE HAZARDOUS TO LIFE AND LIMB. BE WARNED FOR LONG PERIODS TO BE EXPOSED TO THIS CAPACITOR BANK. THE CAPACITOR BANK IS A DANGEROUS SOURCE OF ENERGY. CONTACT THE MANUFACTURER FOR MORE INFORMATION." A red arrow points to the top of the module.</p>



Removing the AUX Power Connector

Tools Required

- Socket, 9100-3060-AF
- Large diagonal cutters

Setup

- This procedure should be conducted on a static mat.
- Wear a wrist strap to ground during the procedure.
- Complete these procedures in the following order before performing this procedure:
 1. “Removing the Handle” on page 61
 2. “Removing the Printer Module” on page 62
 3. “Disassembling the Main Unit” on page 64
 4. “Removing the Defibrillator Boards and Capacitor Bank Modules” on page 86

AUX Power Connector	
<p>1</p> <p>Disconnect AUX Power Connector cable from harness.</p>	
<p>2</p> <p>Using socket, 9100-3060-AF, remove lock nut that is securing the connector to the housing.</p> <p>Note: During reassembly, apply a drop of loctite before secure the lock nut.</p>	

Note: During reassembly, line the white dot on connector with the arrow on the housing.

Note: During reassembly, torque screws to 10 in-lbs.



Removing the Dock Connector

Tools Required

- #1 Phillips screwdriver with torque capability

Setup

- This procedure should be conducted on a static mat.
- Wear a wrist strap to ground during the procedure.
- Complete these procedures in the following order before performing this procedure:
 1. “Removing the Handle” on page 61
 2. “Removing the Printer Module” on page 62
 3. “Disassembling the Main Unit” on page 64
 4. “Removing the Defibrillator Boards and Capacitor Bank Modules” on page 86

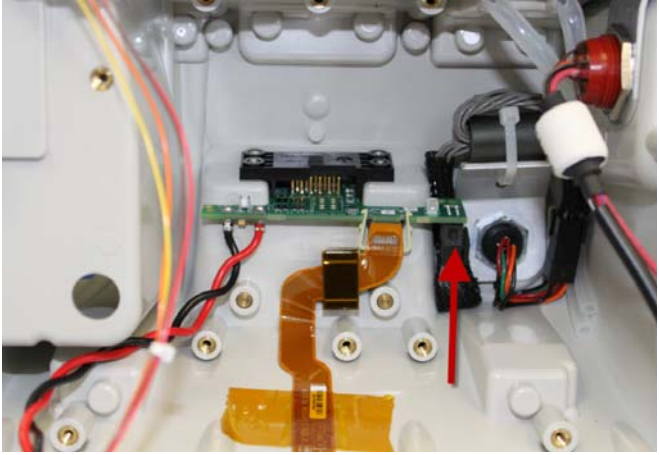
Dock Connector	
<p>1 Remove 4 screws and washers from the back panel that are securing the dock connector to the housing.</p> <p><i>Note: During reassembly, torque screws to 6 in-lbs.</i></p>	
<p>2 Disconnect black connector from the dock connector board.</p>	

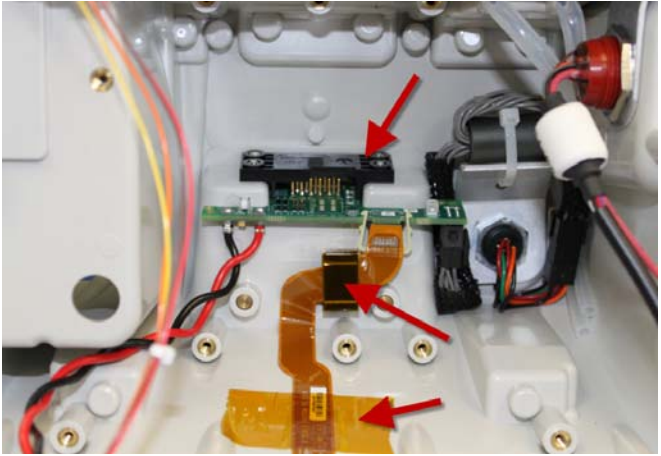
<p>3 Remove tape securing the flex cable to the housing, and then peel back the ferrite that is attached to housing. Remove mounting bracket and lift the dock connector board out of the unit.</p>	
--	--

(This page intentionally left blank.)

Chapter 4

Replacement Parts

Overview

This section contains a listing of the replacement parts available for the ZOLL Propaq MD devices.

Replacement parts may be ordered through an authorized ZOLL distributor or directly from ZOLL Medical Corporation. The prices for parts are available from ZOLL Medical Corporation's Technical Service Department.

When ordering parts, please provide the following information:

- Propaq MD device model and serial number
- Field replaceable part number
- Description of the replacement assembly

ZOLL Technical Service Department

Telephone: 1-978-421-9655; 1-800-348-9011

Fax: 1-978-421-0010

Email: techsupport@zoll.com

Replacement Parts List

Items numbers correspond to the parts pictures and diagrams beginning on page 102.

Part Number	Description	Item #
705517	HANDLE,BOTTOM,OVERMOLD	1
705519-03	HANDLE, TOP HOOK	2
0162-0263	SCR.M4-JIS.MCH.16.PNH.PHL.STL ZNC	3
705524-02	COVER,SCREW,HANDLE,HOOK,RIGHT	4
705523-02	COVER,SCREW,HANDLE,HOOK,LEFT	5
705510	SCR, M3, TFM, 10, PNH, PHL, STL, ZNC, PLASTIC TAPPING	6
705164	WASHER.FLAT.M4.4.3MM ID.7.00MM OD.0.50MM THK.NYL..WHITE	7
708438-02	CATCH, BATTERY, REAR DEFIB	8
705542	SCREW.PAN HEAD.M4X8.STEEL.ZINC PLATING.PHILIPS DRIVE	9
1017-0160-01	ASSY, FILTER, NIBP	10
9161-0040	GASKET, VENT CAP SECONDARY, PROPAQ	11
704992-02	COVER, FILTER RECESS	12
705511	PLUNGER, COUNTERBALANCE	13
705513	SPRING,BATTERY COUNTERBALANCE,DEFIB	14
705512	BRACKET, PLUNGER COUNTERBALANCE, DEFIB	15
707681	SCR PNH PHL M3 MCH 6 STL ZNC	16
705544	WSH, M3, FLT, 6.86MM OD, 3.3MM ID, 0.5MM THK, NYL	17
600-0398-00	PAD.FOOT.SILICONE.BLACK.0.5" SQUARE.0.12"HIGH	18
705515-99	REWORK, LATCH, DOCK RIGHT	19
705516-99	REWORK, LATCH, DOCK LEFT	20
705547	SCR M4 MCH 10 FLT PHL STL ZNC 90 DEG	21
707716	SCR M3 MCH 16 PNH PHL STL ZNC	22
9500-000679	HARNESS, AUX CONNECTOR,	23
9161-0463	GASKET, AUX PWR	24
9320-0093	BRACKET, FERRITE, AUX PWR	25
9330-0944	FOAM, TAPE, VHB 4952, 1.25 X .50, R SERIES	26
9500-0650	ASSY, RECEPACLE, DEFIB CABLE	27

Part Number	Description	Item #
9320-0787	MFC BACKING TAB	28
0500-0014	TUBING.SILICONE.CLR.1/8" ID. X 1/4" OD	29
620-0403-00	CABLE TIE.NYLON,.14"X.05"X7"	30
9500-000688	ASSY, CABLE, IN-LINE AUX FERRITE,	31
9301-000269-01	ASSY, PCB, DOCK CONNECTOR,	32
9301-000277-01	ASSY, PCB, CABLE, FLEX CIRCUIT, SYSTEM-TO-DOCK,	33
9310-000694	BRACKET, DOCK CONNECTOR,	34
403871	ASSEMBLY BATTERY CONNECTION	35
9500-000686	CABLE, ASSY, BATTERY, POWER	36
9330-0149	CONTACT, SOCKET, .059", 10A, #4 STUD	37
0163-0016	WASHER, FLAT, #4, SS	38
0163-0285	NUT, KEPS, 4-40, SS	39
9126-0010	HV CAPACITOR, 100UF	40
9330-000573	FOAM BUMPER, 9301-1251 PWB	41
9500-1720	CABLE, POWER, MONITOR-TO-PACE	42
9310-0682-99	REWORK, SUPPORT FRAME, PACE BOARD	43
9301-001251-02	ASSY, PCB, ECG BOARD	44
705541	SCR, M4, MCH, C0, PNH, PHL, STL, ZNC	45
9301-1250-01	ASSY, PCB, PROCESSOR/BRIDGE/PACE BOARD	46
9310-0683	ISOLATOR, PACE TO MONITOR	47
0140-0103	MAG.CORE.FERRITE.0.640 X 1.64.ROUND CABLE SNAP ON	48
0501-0001	TY-RAP CABLE TIE STD 18 LB .093W X 3.62 L	49
9310-0681	REAR CASE,	50
708502	GASKET,MAIN ENCLOSURE	51
707717	SCR PNH PHL M3 MCH 10 STL ZNC	52
9302-0253-01	ASSY, FLEX CBL, BRIDGE/PACE-TO-ECG	53
9320-0788	SHIELD, ECG, PRIMARY SIDE	54
9301-0252-01	ASSY, PCB, MONITOR BOARD,	55
7608-000001-01	SPO2 MX-3 BOARD	58
9330-000570	ISOLATOR, CP MODULE,	59
9320-000792	BRACKET, HEAT SPREADER,	60

Part Number	Description	Item #
9330-000568	PAD, THERMAL, 19MM X 19MM,	61
3027-000003	PWBA, CARRIER, C	62
9310-000753-99	REWORK,BRACKET, CP ANTENNA,	63
3027-000002	PWBA, ANTENNA, CP	64
9500-000690	CABLE, GPS	65
0500-000354	Cable Assy, RA MHF - RA MHF 36AWG 0.81mm COAXIAL115mm BLK	66
0500-000352	CABLE RF MICRO COAX PCB 50OHM 0.81MM DIA 150MM OAL	67
9320-000791	CLIP, GND, CP ANTENNA,	68
705510	SCR, M3, TFM, 10, PNH, PHL, STL, ZNC, PLASTIC TAPPING	69
0162-000087	SCR, M2, MCH, 5, PNH, PHL, SST	70
9320-000790	SHIELD, CP CARRIER,	71
9330-000569	PAD, THERMAL, 15MM X 15MM,	72
9500-000793	Harness, Fan	73
707681	SCR PNH PHL M3 MCH 6 STL ZNC	74
9301-0256-01	ASSY, PCB, FLEX CBL, SPO2 CONN PCB - SPO2 MODULE,	75
9301-0254-01	ASSY, PCB, FLEX CABLE, SPO2 MODULE,	76
707682	SCR, M3, TFM, 8, PNH, PHL, STL, ZNC, PLASTIC TAPPING	78
9500-000685	CABLE ASSY, LCD,	79
9310-0674-03	SPIDER FRAME, Propaq XM	80
0501-0001	TY-RAP CABLE TIE STD 18 LB .093W X 3.62 L	81
1007-000504-01	ASSY, RIGHT SIDE PANEL,	82
707680	SCR, M3, MCH, 8, PNH, PHL, STL, ZNC	83
1007-000503-01	ASSY, LEFT SIDE PANEL, MASIMO/ORIDION,	84
705415	GASKET,SIDE PANEL,SPIDER	85
403883	SUB ASSY, NIBP PUMP/VALVE/BRACKET	86
405849	PCA, BP OEM, (MODG, CALIBRATED)	87
9320-0095	DEFLECTOR, AIR, MOD G	88
0162-0017	WASHER, FLAT, M3, SS	89
705880	SPRING CLIP, TUBING CLAMP	90
1027-000180-01	SUB ASSY, ETCO2,	91

Part Number	Description	Item #
705440	DISPLAY.LCD MODULE.TFT COLOR.17CM.640X480.800MCD	92
706659	BOOT RUBBER, DISPLAY	93
0550-0037	TAPE COPPER 3/4" W/CONDUCTIVE ADHESIVE	94
1007-000126	ASSY, DIE CAST,	95
0162-0081	SCR,M3X4, PNH, PHL, SST	96
1037-000001-01	Assy, Front Encl, Propaq XMD	97
708502	GASKET,MAIN ENCLOSURE	98
0160-000303	STDOFF,14,M3,STL,Female,FF,HEX, ZNC	99
707681	SCR PNH PHL M3 MCH 6 STL ZNC	100
9301-0272-01	ASSY, PCB, FLEX CBL, DEFIB-MONITOR, SHIELDED,	101
0163-1709	SNAP RIVET BLACK NYLON	102
707354	SCR,M4,MCH,60,PNH,PHL,STL,ZNC	103
705541	SCR, M4, MCH, C0, PNH, PHL, STL, ZNC	104
705164	WASHER.FLAT.M4.4.3MM ID.7.00MM OD.0.50MM THK.NYL..WHITE	105
1007-000502-01	PRINTER ASSEMBLY,	106
9305-000690-01	LABEL, I/O PANEL RIGHT SIDE, TEMP/IBP, USB,	107
705162	LABEL, DEFIB,	108
9305-000708-01	LABEL, Nomenclature	109
9305-000707-01	LABEL, L1-PNL ECG/SPO2 MA/NIBP/ETCO2	110
1027-000015-01	ASSY, MASIMO LABELS,	111
9305-000680-01	LABEL, LOGO,	112
9305-000681-01	LABEL, L1-PNL ECG/SPO2 MA/NIBP/ETCO2- ORD	113
707740	FOOT,RUBBER,FRONT PANEL	114

Pictures and Diagrams

Picture 1

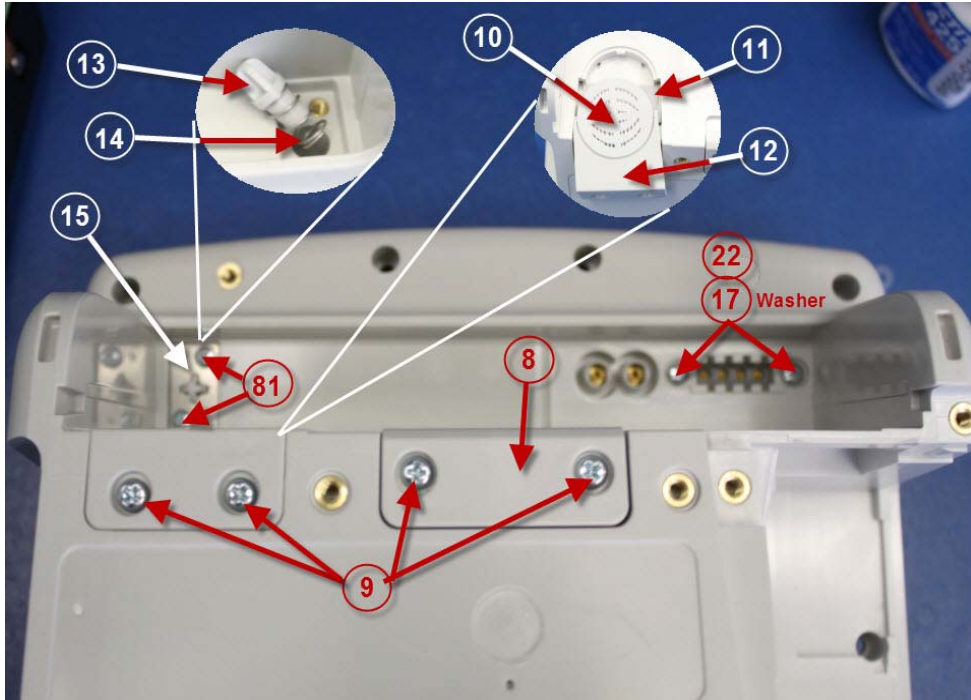

Picture 2

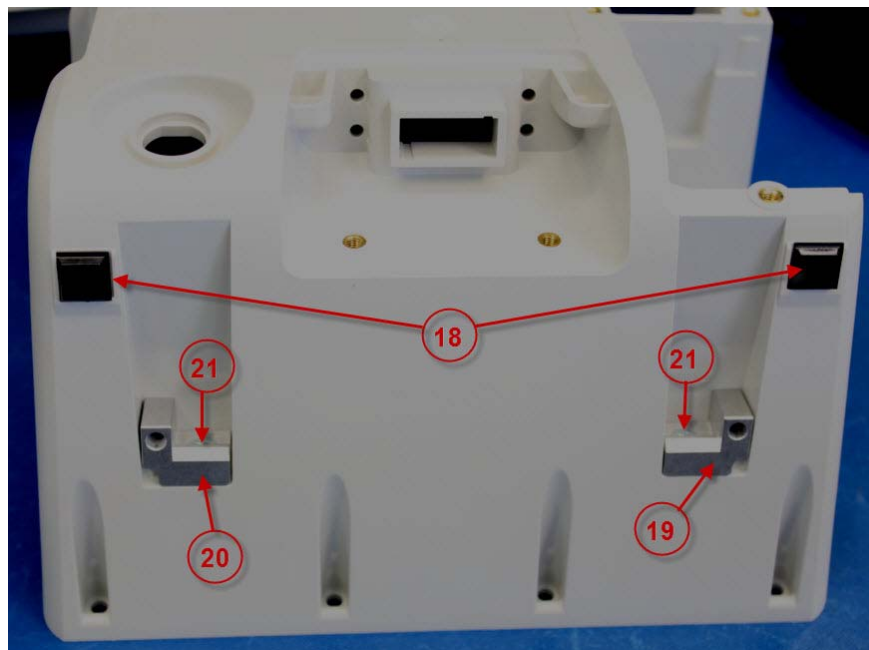

Picture 3

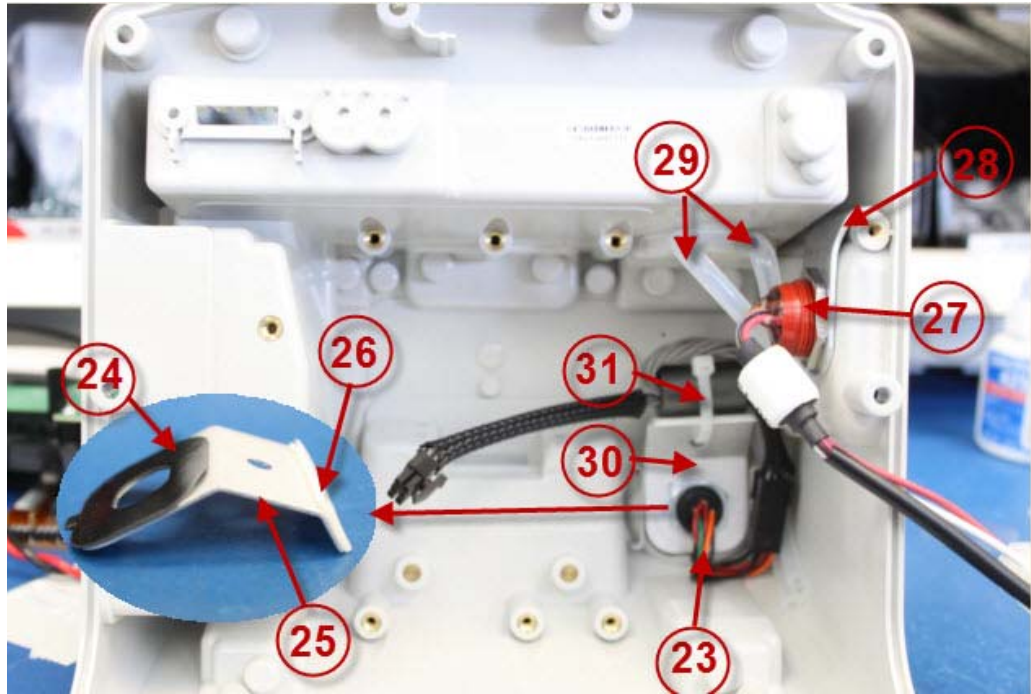

Picture 4

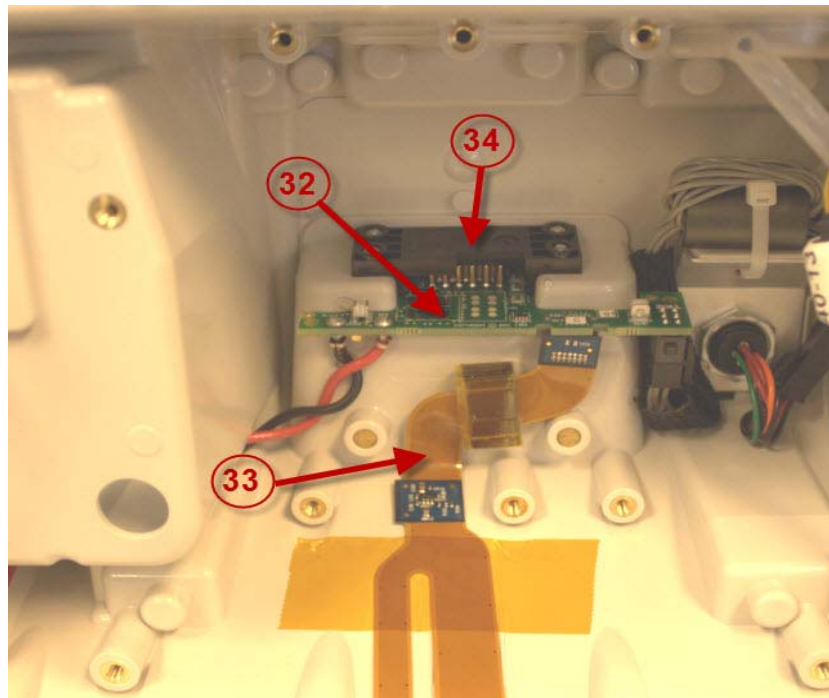

Picture 5

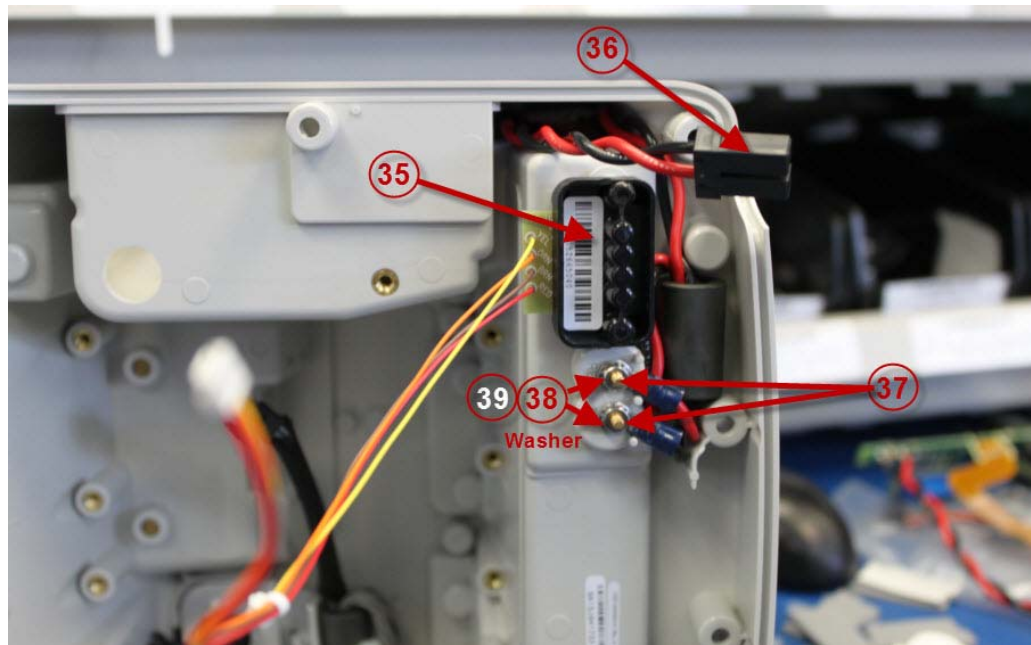

Picture 6

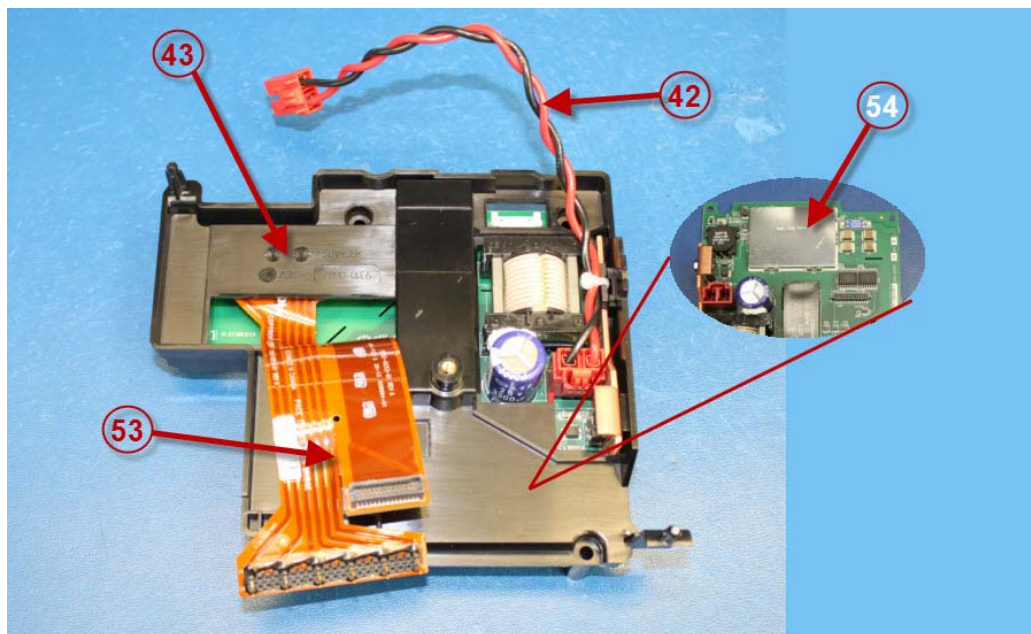

Picture 7

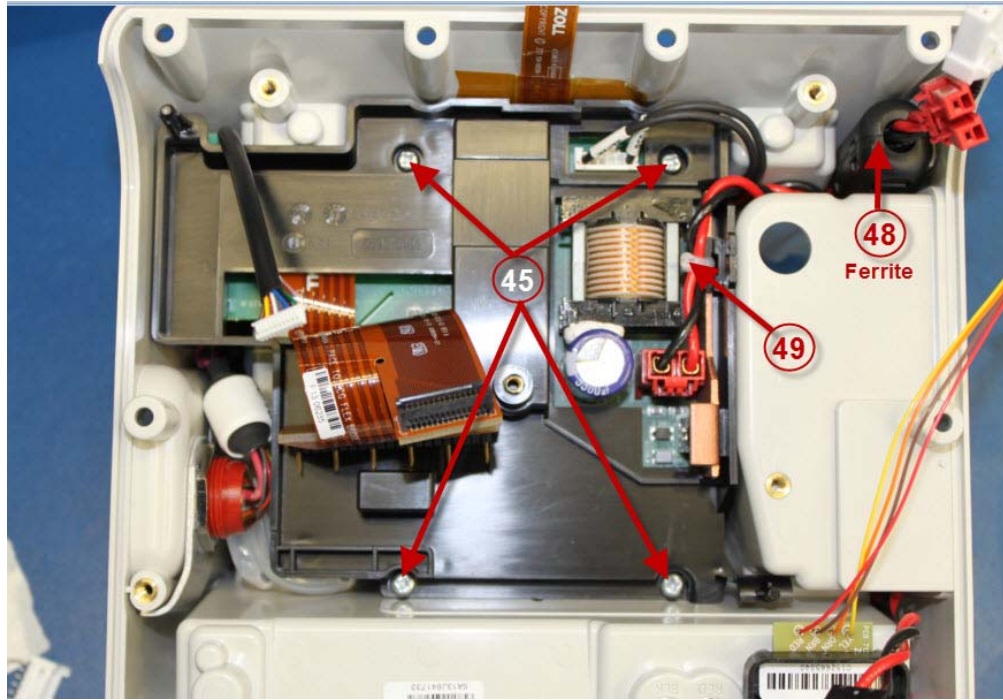

Picture 8

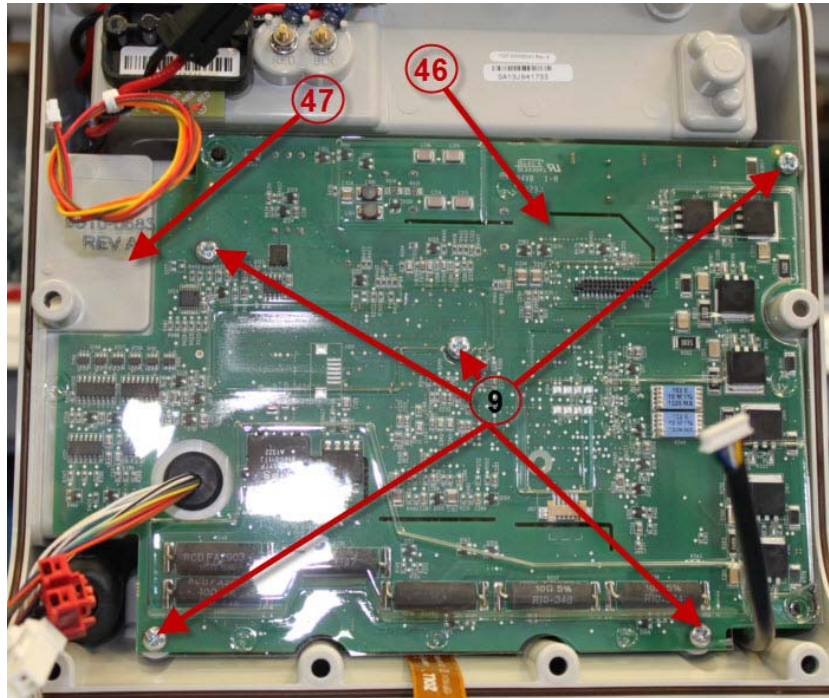

Picture 9

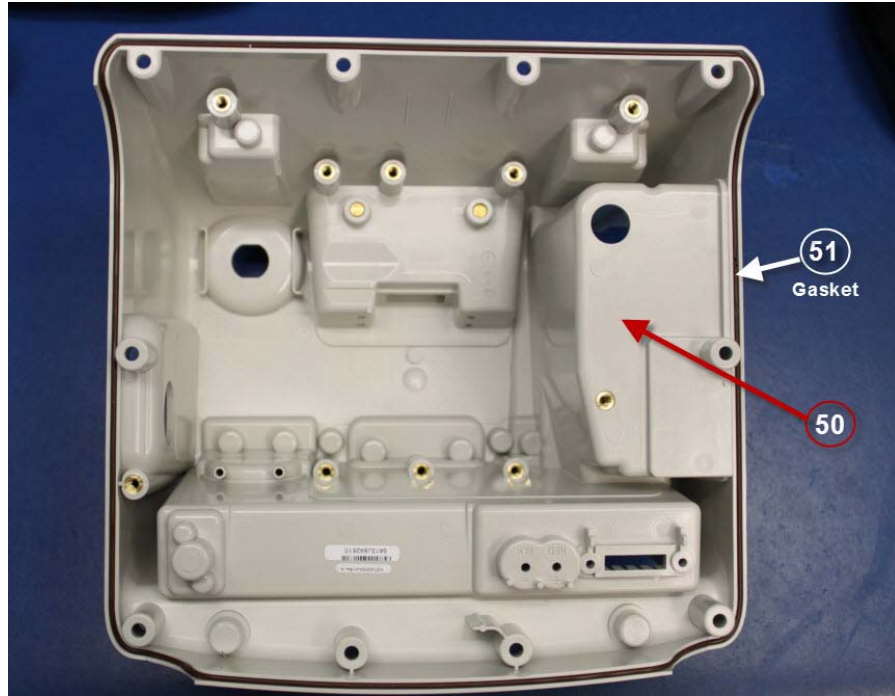

Picture 10

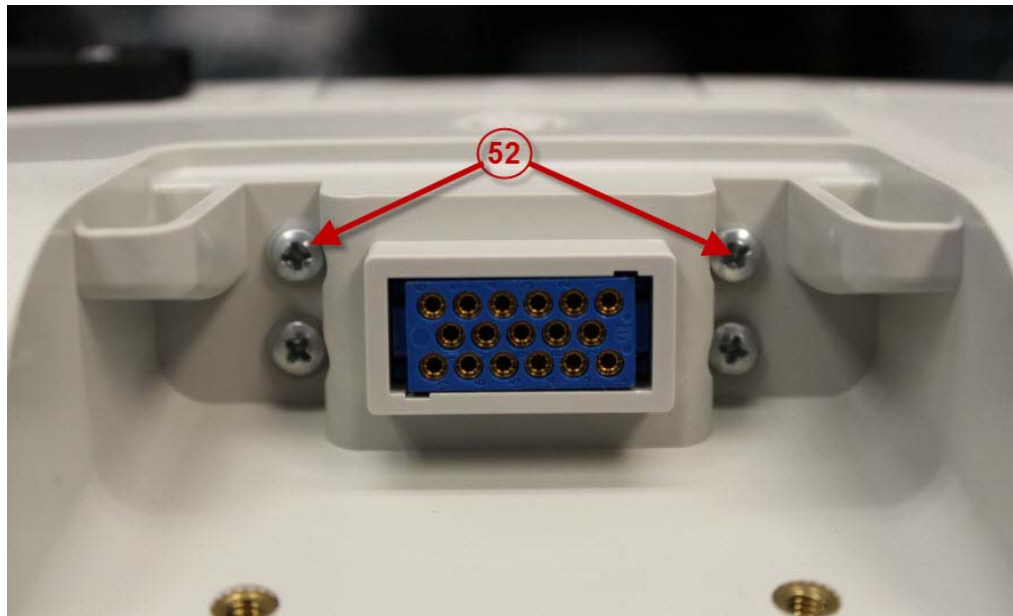

Picture 11

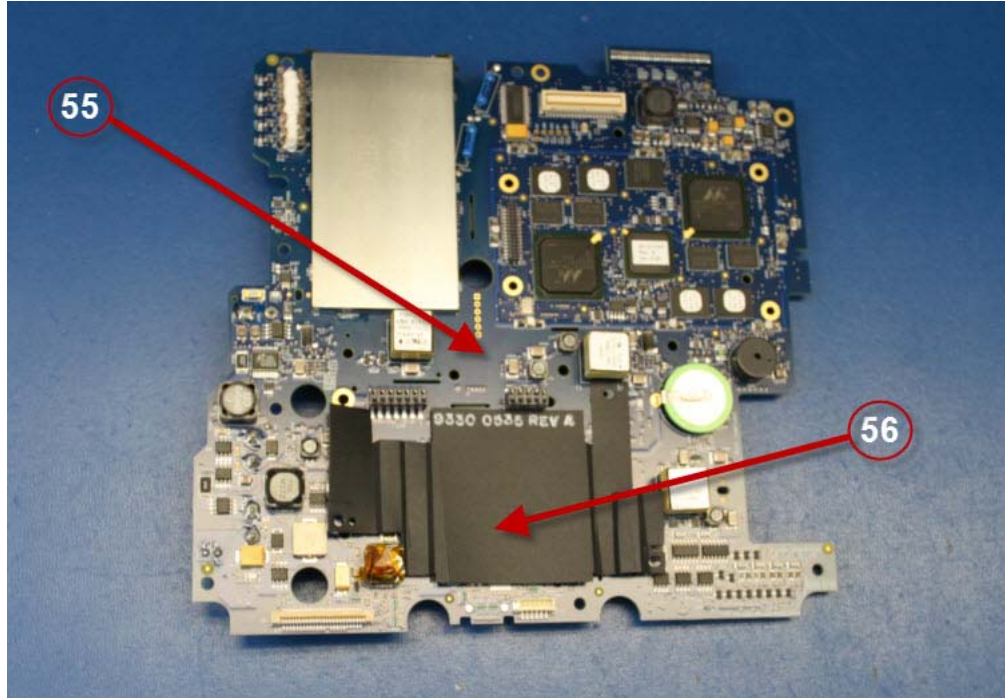

Picture 12

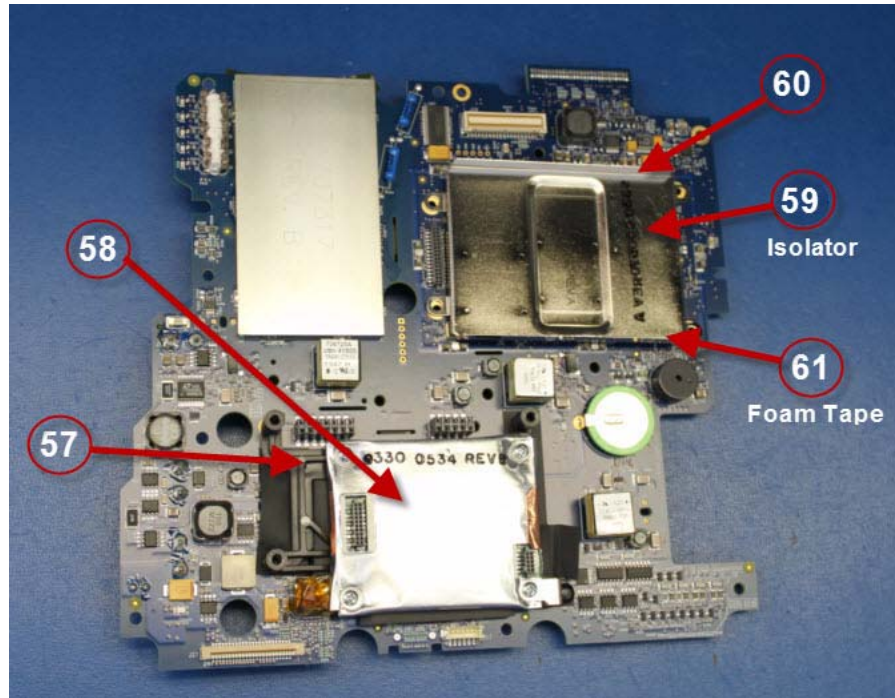

Picture 13

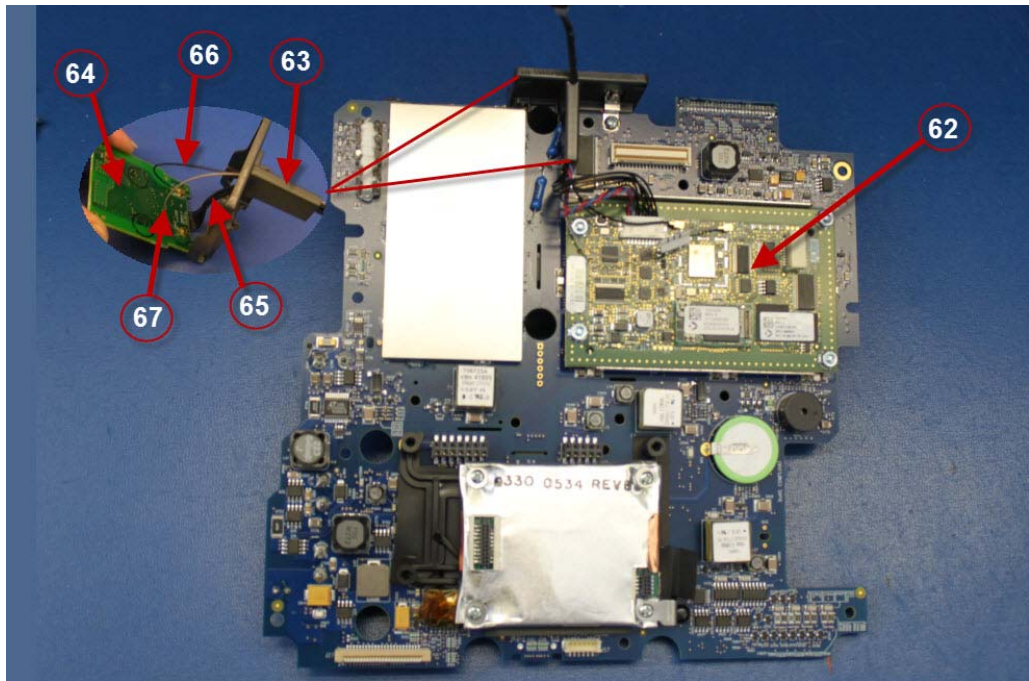

Picture 14

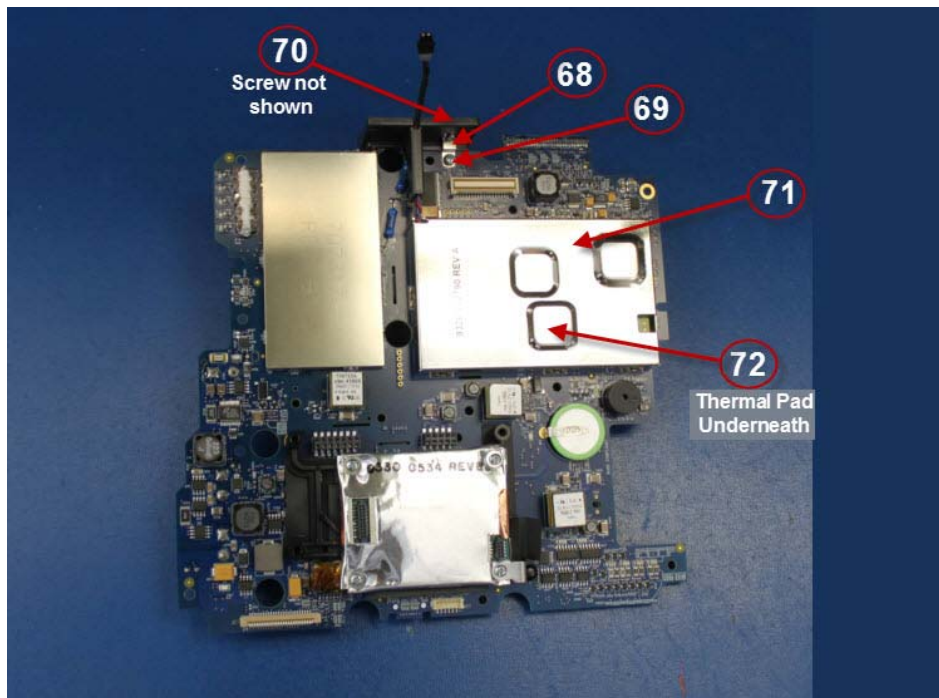

Picture 17

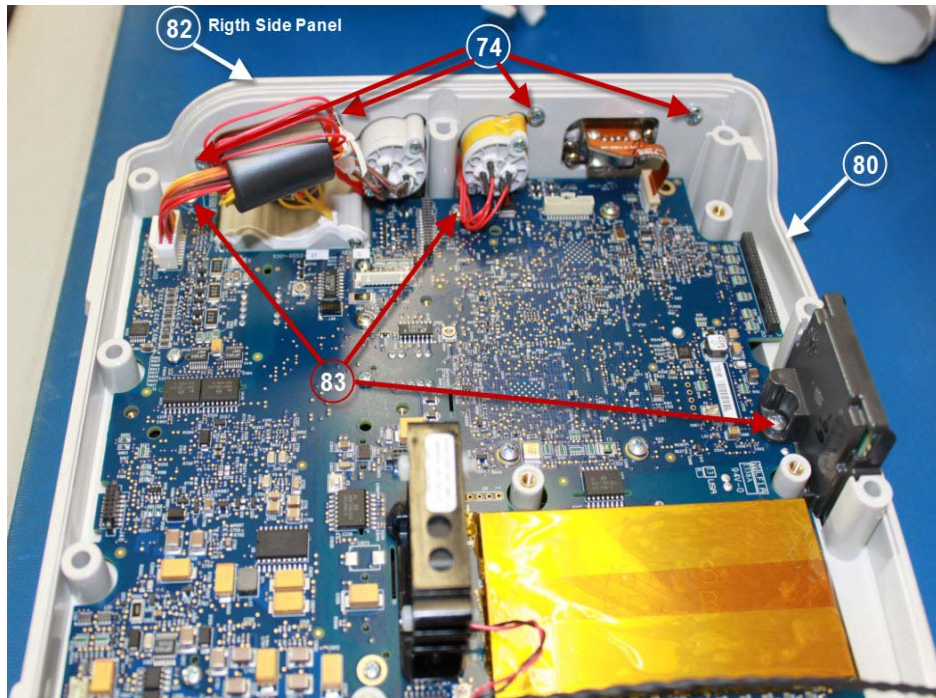

Picture 18

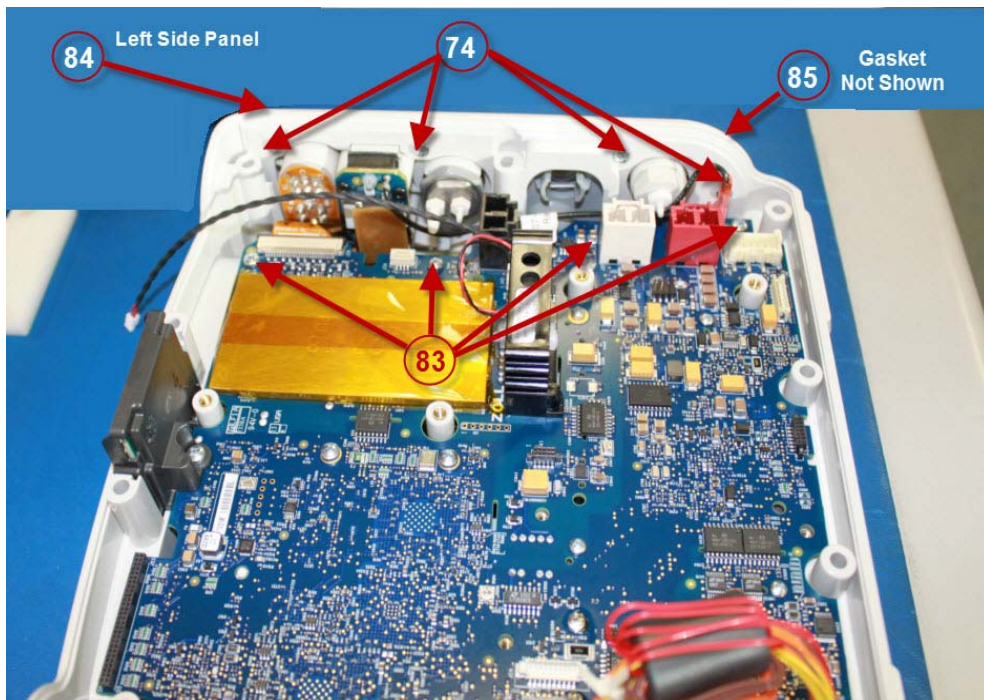

Picture 19

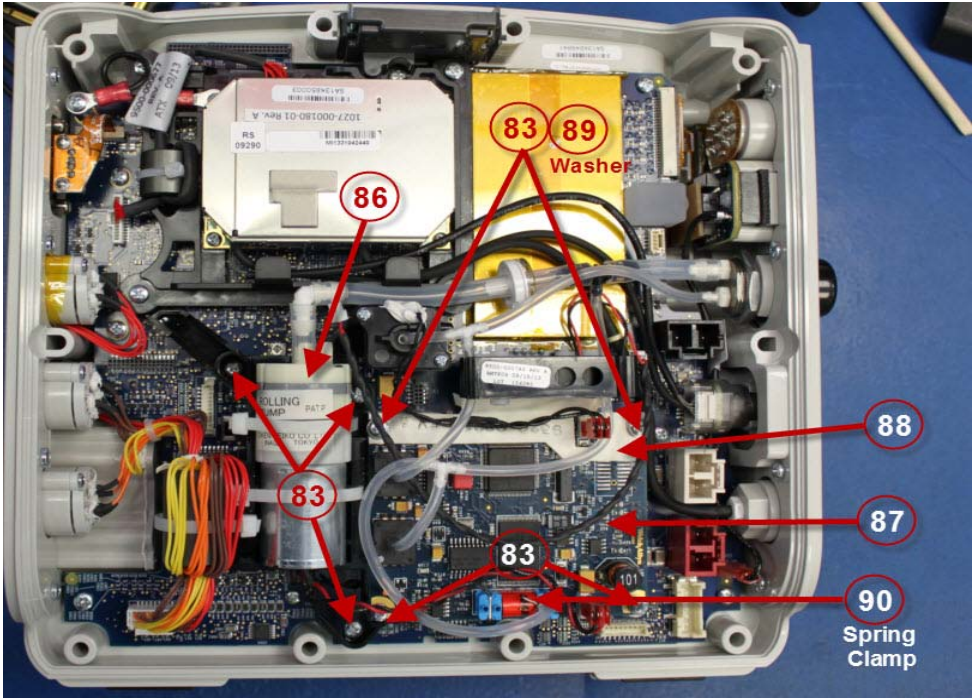

Picture 20

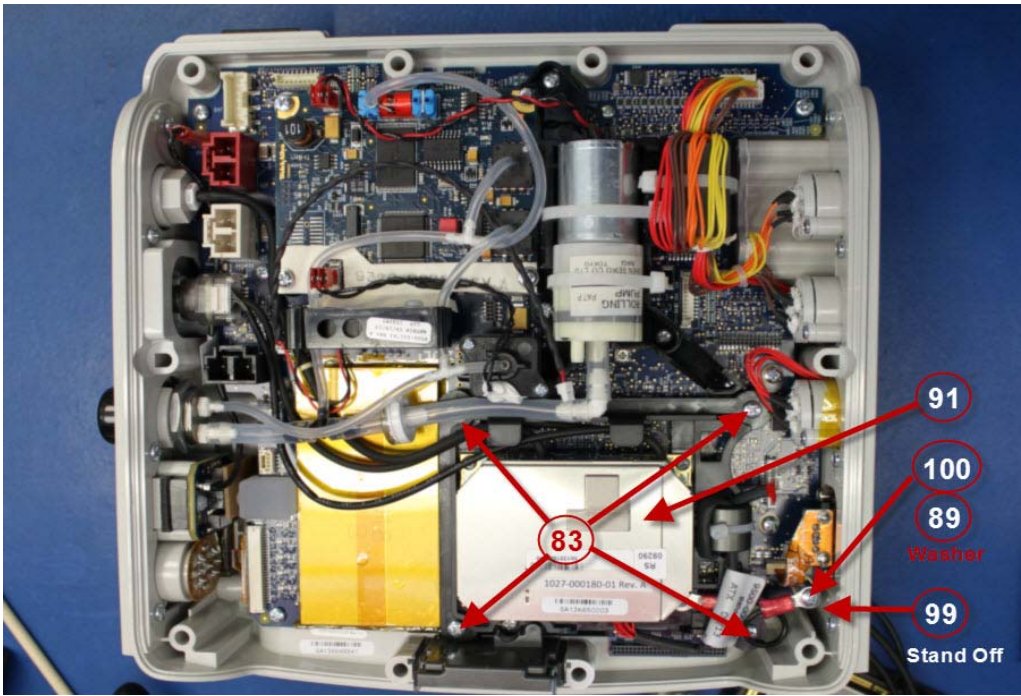

Picture 21

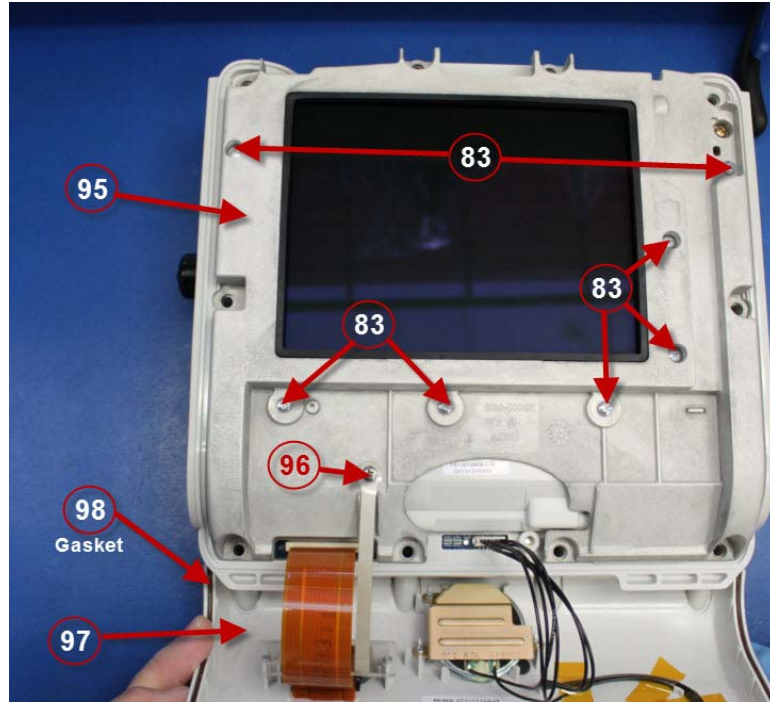

Picture 22

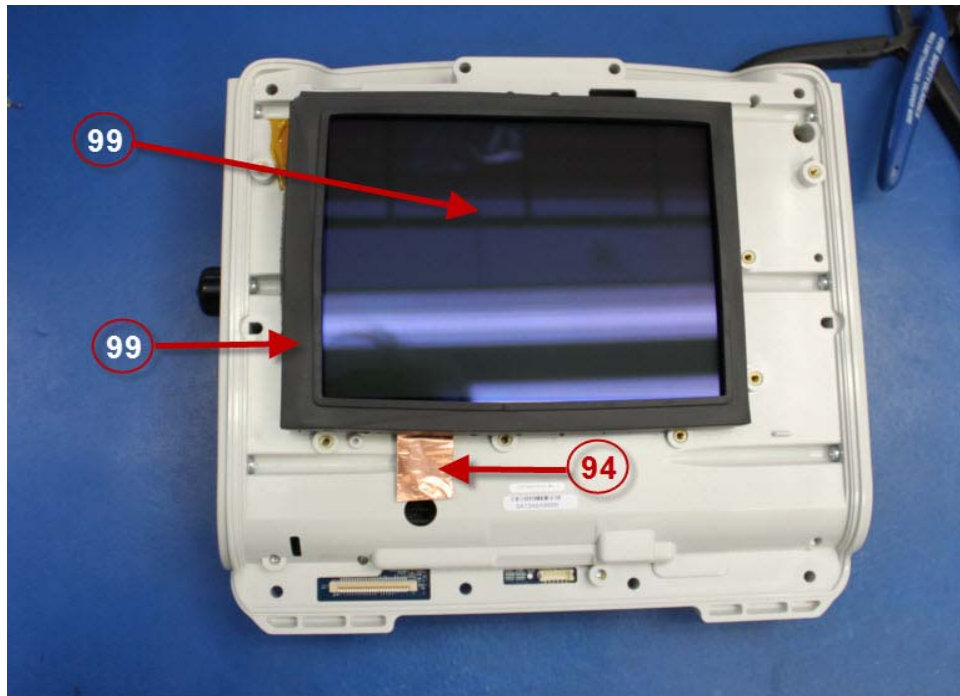

Picture 23

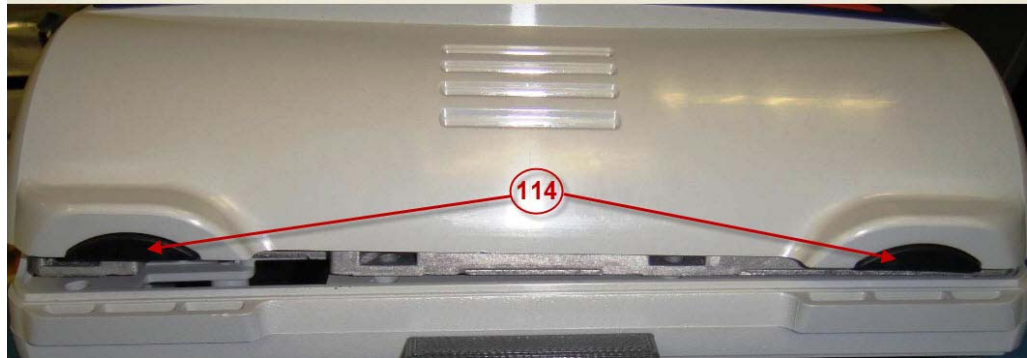

Picture 24

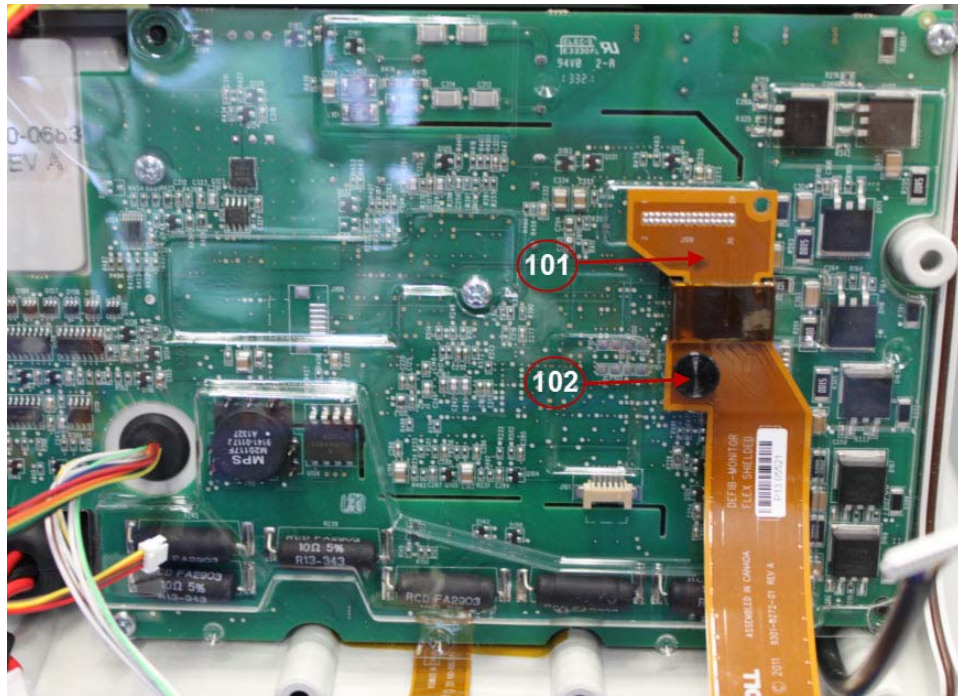

Picture 25

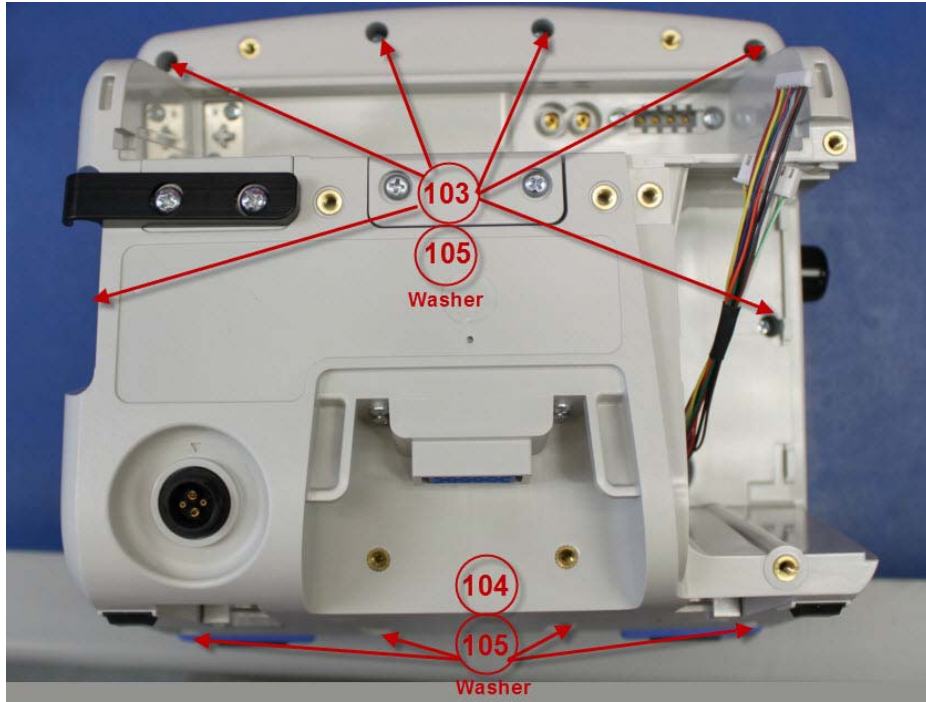

Picture 26

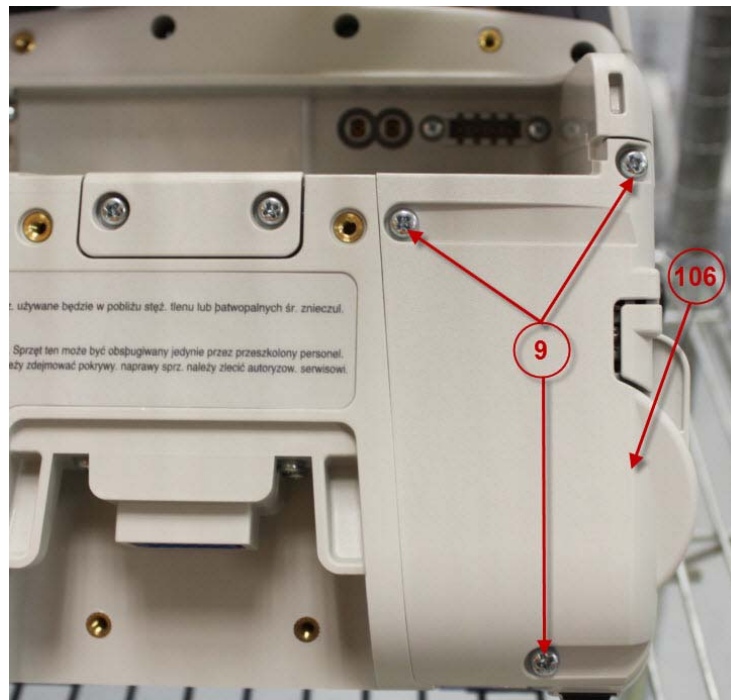

Picture 27

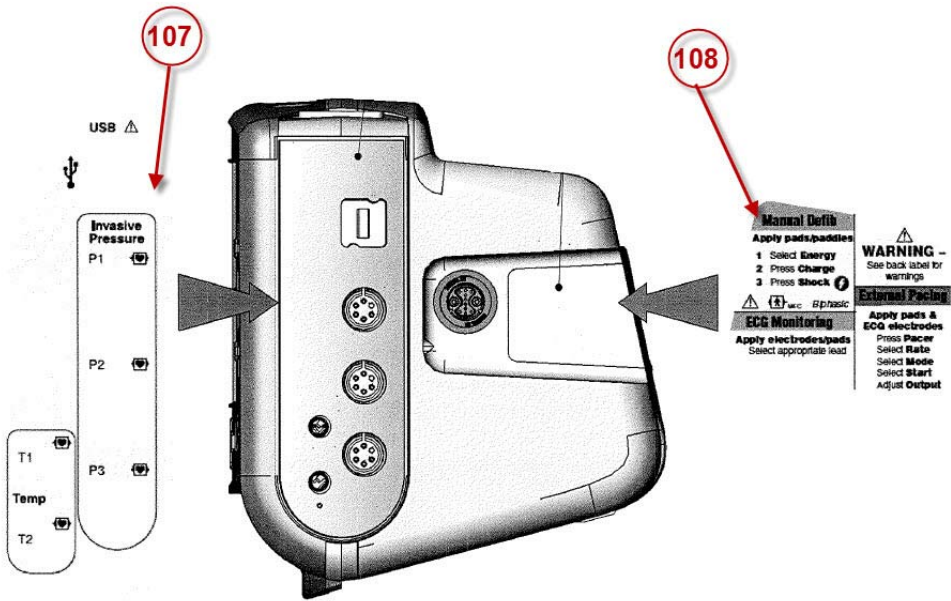

Picture 28

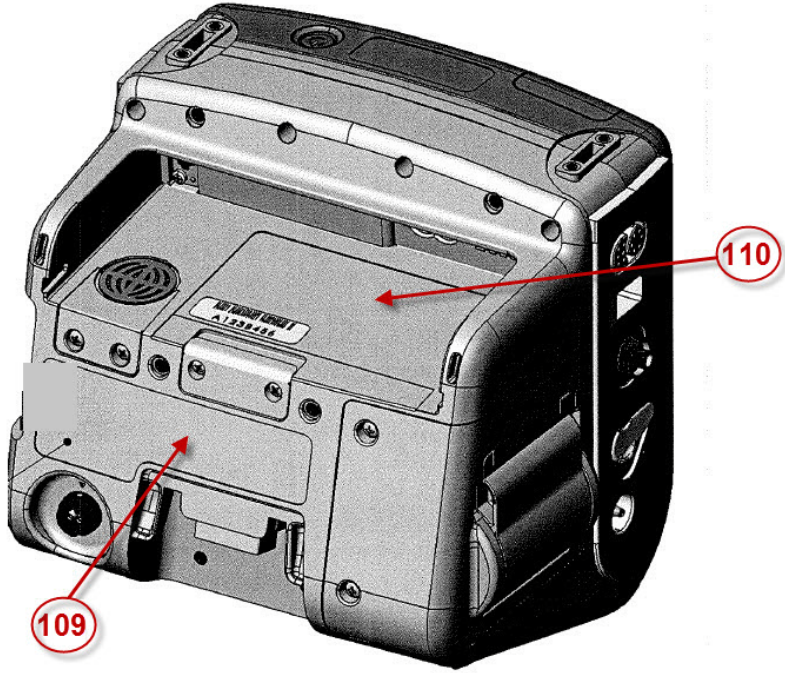

Picture 29

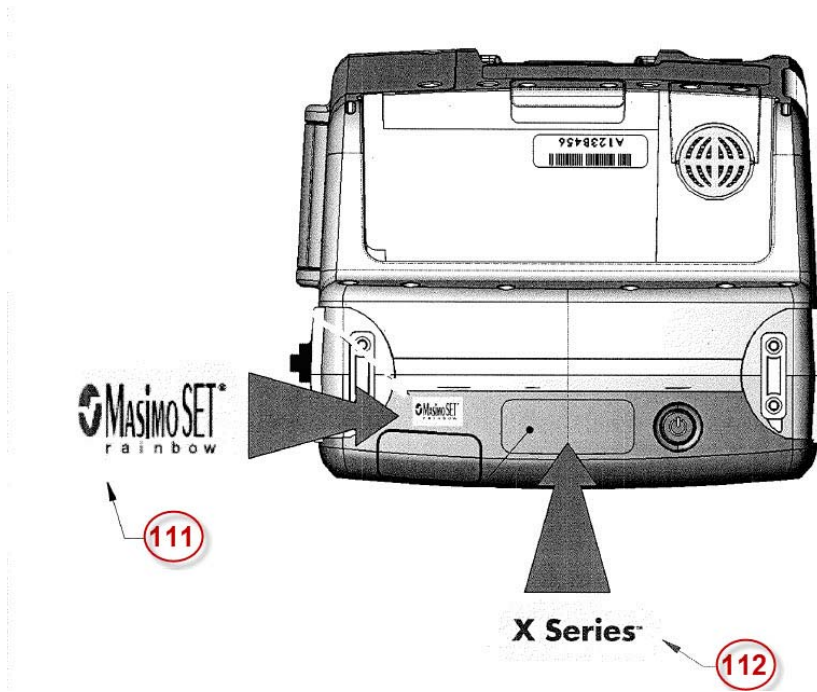

Picture 30

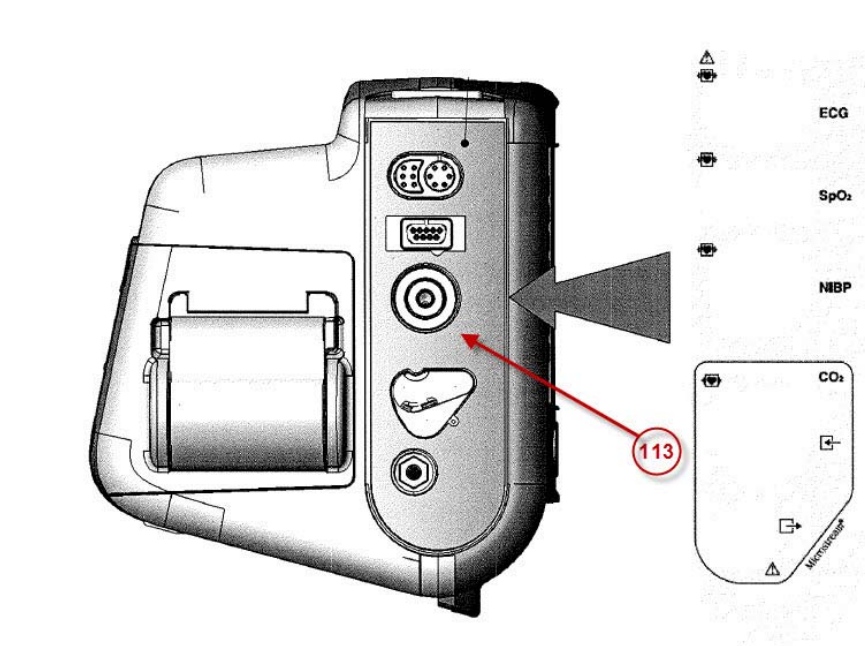

Picture 31

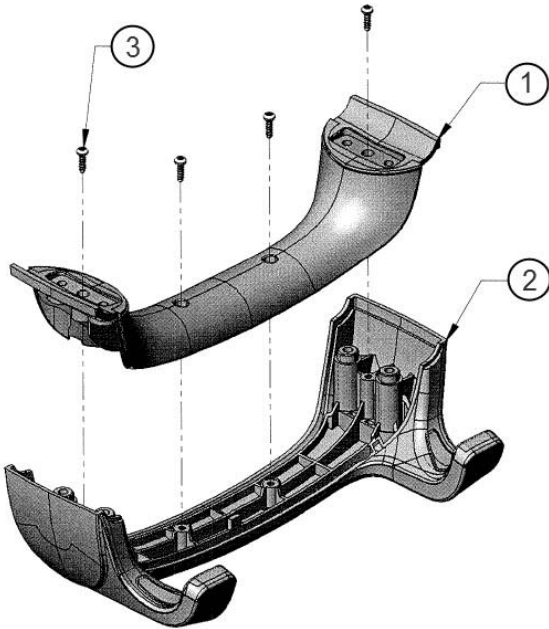

Picture 32

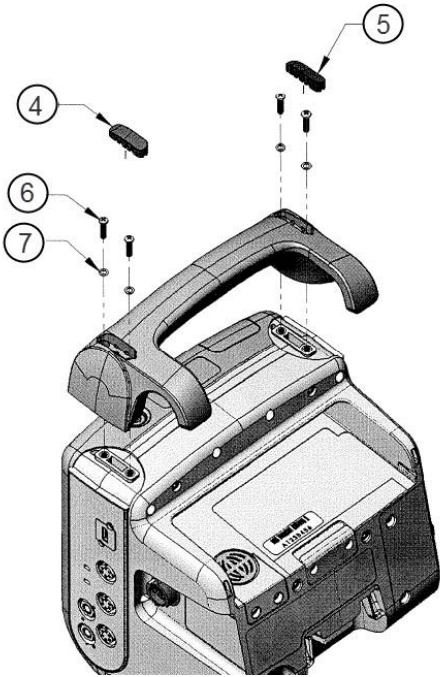

Chapter 5

Functional Description

Overview

This chapter contains functional descriptions of the components contained in the Propaq MD and the Propaq MD options.

Circuit Distribution

The Defib/Monitor Propaq MD unit consists of two key PCB assemblies, the Monitor Board and the Defibrillator Board as well as a few modules and assemblies: the Front Panel Keypad assembly, Status LCD Board, Dock Connector Board, Display, and Printer. The NIBP, CO₂, and SpO₂ circuitry reside on modules that connect to the Monitor Board.

Monitor Board

The Monitor board integrates the analog circuitry and interface circuitry for patient parameters, a digital processing section as well as user interface controls, printer control, audio control, and power circuitry for the entire system and charging circuitry for the battery. The Propaq MD system relies on a centralized dual processor engine for its computing needs. The Main Processor (MP) serves as the primary user interface engine and provides connectivity needs, while the Patient Processor (PP) controls the patient monitoring and defibrillation-pacing functions. An additional power controller micro-controller (PC) controls the power sequencing, and battery/charger interface.

Main Processor (MP)

The Main Processor (MP) section controls the user interface, connectivity needs, as well as data logging, printing, and general system control. It consists of the CPU, program memory Flash and SDRAM, Communication with modules/circuits: USB Client, USB Host, Debug Ports (JTAG,Serial), Storage memory for 24 hour disclosure data, Internal VGA display and interface circuit, LED indicators, Key Pad, and Audio circuit. The MP also controls the real-time clock and interface to the power controller processor, battery and charger.

Patient Processor (PP)

The Patient Processor (PP) circuitry supports the data acquisition, signal processing and conditioning, analysis and control algorithms required for the physiological sensors. The PP also controls the defibrillation and pacing circuitry. It consists of the processor, program memory Flash and SDRAM as well as interface circuitry to physiological sensor modules/circuits.

Power Controller (PC)

The Power Controller (PC) micro-controller controls the power sequencing to turn the device on and off when the power switch is pressed. It also communicates to the battery charger and battery via a serial SPI bus. Additionally, the PC controls the Status LCD and communicates battery and charger status to the MP.

Peripherals Interface

The Communications Processor (CP) is connected to various peripherals:

- MP
- Host Power Control
- USB
- Wifi
- Bluetooth
- GPS
- Expansion FLASH Storage

MP - The CP is connected to the MP via several communication links. The primary link is a high-speed UART with several GPIO lines for general signaling. Additional provision has been made for connection with an SPI link that would operate in parallel to the UART. The CP can perform message-based communication with peripherals that are connected to the MP, such as the PP, the real-time clock and power controller through the MP.

Host Power Control - The CP uses the Host systems' power controller - HC08 - for system power state information. This link consists of several GPIO lines. This link provides information about the connected power sources, imminent shutdown and handshaking.

USB - The USB interface on the CP provides a means to connect USB memory sticks and USB Cellular Modems.

Wifi - The Wifi interface on the CP is provided over an SDIO interface with auxiliary GPIO lines for control. This provides the capability for communication with a/b/g/n 802.11 devices. Collectively, this interface allows the CP to control power, scan for available networks and to select/deselect a desired connection.

Bluetooth - The Bluetooth interface on the CP is provided by a UART interface with auxiliary GPIO lines for control. Collectively, this interface allows the CP to control power, scan for available devices and to select/deselect a desired connection.

GPS - The GPS interface on the CP is provided by a UART interface with auxiliary GPIO lines provided for control. Collectively, this interface allows the CP to control power and to listen for satellites. The UART interface is jumpered and also routed to the expansion connector to provide a means for accessing the CP's console debug port. If the console port is enabled, the GPS interface will not be available and vice-versa.

Expansion FLASH Storage - This consists of a block of supplemental FLASH that is physically separate from the NAND FLASH used to store the boot loaders, kernel and system software. This partition is used to store upgrade images, patient data and device log data. This storage exists on the carrier board and is connected to the CP via an SD interface.

ECG 3/5 or 12 Lead Circuitry

Propaq MD supports 3/5 lead and 12 lead ECG acquisition. Analog circuitry provides signal conditioned data through an A/D converter to the PP. All of the signal processing, lead derivation, fault detection is performed by the PP. The ECG circuitry utilizes a CPLD for control of analog circuitry and transmission of data to the PP across an isolation barrier. A common connector is used to receive 3/5 Lead ECG cables with a 12 Lead ECG extension. The ECG acquisition inputs are CF defib-proof applied parts. The defib protection resistors reside in the patient cable. The ECG signals from the external connector on the left side panel are connected to the monitor board through a flex cable to J28.

Impedance Respiration

Propaq MD provides the circuitry for impedance respiration measurements in 3/5 and 12 lead configurations. This circuitry provides a low-current 72kHz AC signal across leads I and II of the ECG cable. The signal is passed through a synchronous demodulator and decoded by the PP through the ECG CPLD.

Blood Pressure NIBP

The Propaq MD NIBP circuitry resided on module that connects to the Monitor board through J32. The PP communicates to the NIBP module via a bi-directional, serial bus. The NIBP module supports both dual lumen and single lumen cuffs. The NIBP pump and valve hoses are connected to the cuff connector on the left side panel and to the filter on the rear enclosure. The pump and valve are connected to the NIBP module by short, 2-wire cables.

Invasive Blood Pressure (IBP)

Propaq MD supports up to 3 IBP measurement channels. The IBP circuitry supports AAMI BP-22 transducers (5uV/V/mmHg). The PP communicates directly to the IBP ADC over an isolated serial bus through the FPGA. The IBP probes connect to the monitor board through the IBP/Temp wire harness which connects to J33 of the Monitor board.

SPO₂ Module

Propaq MD supports the Masimo Module that mounts to the Monitor board and communicates through J36 and J40. The SpO₂ module communicates across an isolation barrier using a UART on the PP. Signals from the probe are routed to the SpO₂ module through a flex cable that connects to J41 of the Monitor board.

End tidal CO₂ (CO₂)

Propaq MD supports an Oridion[®] Microstream[®] CO₂ module. The CO₂ module mounts to the Monitor board and communicates to the board through a cable connected to J50. Serial communications from the monitor board is implemented via a UART on the PP. The CO₂ module obtains gas samples from the sampling lines through tubing and a 3-wire cable connected to the left side panel.

Thermometry

Propaq MD supports two simultaneous temperature measurements. YSI400/YSI700 series probes are used to make temperature measurements. Data is communicated to the PP from the Temperature ADC via an isolated SPI bus through the FPGA. The Temperature probes connect to the monitor board through the IBP/Temp wire harness which connects to J33 of the Monitor board.

Power Circuitry, Battery Charger, DC-DC converters

Power circuitry for all subsystems but the defibrillator-pacer module reside on the Monitor Board. Auxiliary Power and Battery Power are automatically switched to provide constant current, the unit draws current from auxiliary power when present. There is a smart battery charging circuit that will charge the battery when Auxiliary power is present. Switching mode DC-DC converters are utilized to make internal 6V, 5V, 3.3V, 1.8V and processor core voltages. Regulators are used to provide regulated supply voltages with low dropout for low current consumption circuits. Each of the isolated modules, Temp/IBP, ECG, SpO₂ have independent power supplies. Isolated power supplies are designed for isolating Patient Applied Parts. The MP via the FPGA GPIO has the ability to shut down voltage rails or power to individual patient parameters. Power from the battery connects to the Monitor board through J29. Auxiliary power connects to the Monitor board through J31.

USB Host Port

Propaq MD Monitor Board incorporates one USB Host ver 1.1 port. The port uses the USB controller built into the PXA270 Main processor. Full speed of 12 Mbps and Low speed 1.5Mbps are supported. The Host port supports a USB flash memory stick for data export. The USB host connector is in the right side panel and connects to the Monitor board through J44.

Defibrillator Pacer Module

The Defibrillator/Pacer Module consists of two PCB assemblies connected by a flex cable. This Defibrillator/Pacer module relies on proven core defibrillation/pacing technology for improved power conversion efficiency, reduced EMI, and improved stability in volume production. This module contains power supplies, charging and discharge circuitry, pacing circuitry, and the Pads/Paddles ECG preamplifier and impedance circuitry. Communication with the Defibrillator/Pacer module is a function of the PP. The ECG-Charger board contains the charger circuit, ECG acquisition circuitry, and protection components. The Processor-Bridge-Pacer board contains the micro controller, CPLD, Pacer, and defibrillation shock delivery circuit.

Defib CPLD

The Defib CPLD provides I/O control for the Pacer circuitry, the defibrillator charging and fire control circuitry.

Pace/Defib (PD) Micro controller

The PD micro controller communicates with the PP processor on the monitor board to accept commands to control the defibrillator and pacer. The PD micro controller controls the pacer current and pulse timing and the defibrillation charging and waveform generation.

Communication between the Monitor and Defibrillator/Pacer boards is routed through the flex cable connected to J106 of the defibrillator board and J38 on the Monitor board.

Charging Circuit

This is a high voltage step-up inverter that charges the Defib Capacitor. It provides electrical isolation between the defib output and the system. The charging circuit will charge the Defib Capacitor to up to 2775V. The Defib Capacitor is connected to the Defibrillator/Pacer board through the 2-wire cable connected to J119.

Fire and Relay Circuit

The fire circuit employs high voltage switching devices to deliver a biphasic waveform to the patient. Switching devices are utilized to produce a Rectilinear Biphasic[®] waveform. In addition, relays are located between the fire circuit and the patient for electrical isolation. They are engaged only when a valid command is set from the Defib CPLD.

Pacer

Pacer circuit delivers pacing pulses under control of the PD micro controller over an isolation transformer. The pacer circuitry consists of an adjustable constant current power supply, pulse timing, and current monitoring circuits.

Pads/Paddles ECG Preamplifier

This is a single channel ECG preamplifier paddle pick up that monitors the patient ECG signal from the Defib paddles (or pads). It digitizes this signal and delivers it to the PP processor via the PP interface. This preamp is a simplified version of the 3/5/12 Lead ECG utilized on the Monitor Board.

Paddle Interface

Paddle interface circuitry detects analog voltage levels to decode switches and ID resistors of the standard ZOLL paddles and internal paddles. The paddle set interface is connected to J115 of the Processor-Bridge-Pace PCB.

Printer

Propaq MD uses an internal thermal printer of 80 mm paper size that is built into the Defib section of the enclosure. Communications with the printer is bi-directional, serial, (Main CPU to/from printer) and complies with the software/hardware interface of the internal printer.

Communications are implemented using hardware Universal Asynchronous Receiver.

Transmitter (UART). The printer is controlled by the MP and is connected through a cable to J46 and J49 of the Monitor board.

Lithium Ion Battery

The portable Propaq MD device is powered by a removable Lithium Ion battery pack. This battery pack incorporates protection circuitry and "smart battery" circuitry. The battery power is routed from the 2-pin connector on the rear of the device to J29 of the Monitor board. The Power Controller communicates to the smart circuitry on the battery through the 4 spring contacts connected to J34 on the Monitor board.

Appendix A

Overview

This appendix includes the following diagrams:

- Propaq MD Electrical Hardware Interconnect Diagram
- Propaq MD Signal and Power Interconnect Schematic

Propaq MD Signal and Power Interconnect Schematic

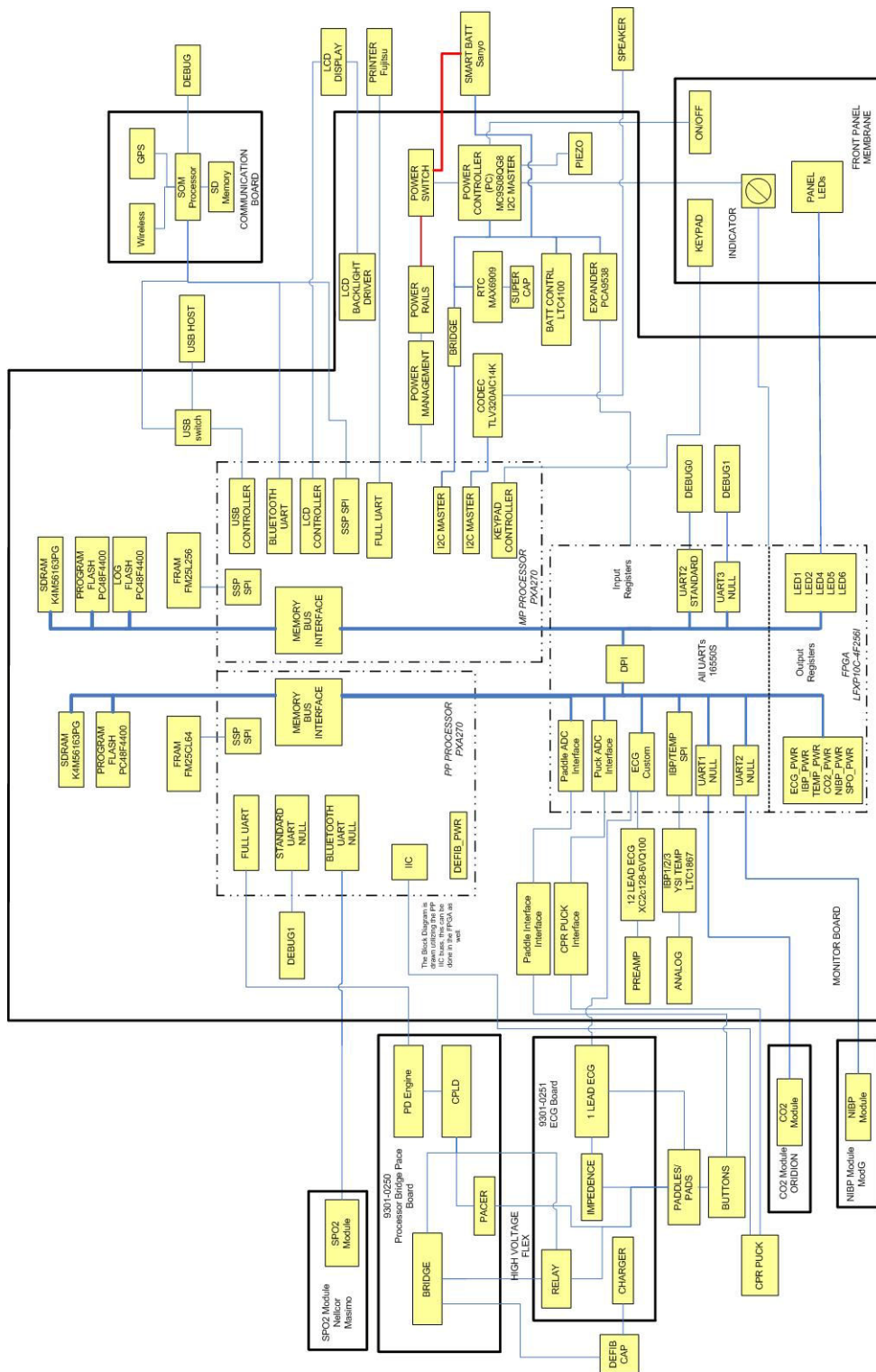

(This page intentionally left blank.)

Appendix B

Overview

This appendix includes simulators and settings that may be used to assess the performance of the NIBP module. Readings should be obtained within +/- 10 mmHg of the expected measurement result. The following simulators are used in this chapter:

- Fluke Biomedical BP Pump/Bio-Tek Instruments BP Pump
- Fluke Biomedical BP Pump/Bio-Tek Instruments BP Pump2
- Fluke Biomedical BP Pump/Dynatech Nevada Inc. CuffLink
- Clinical Dynamics Smart Arm

NIBP Simulator Performance

FastBP

A dual lumen hose is required for FastBP. When you use FastBP, the reading is obtained during cuff inflation.

StepBP

StepBP is compatible with both single and dual lumen hoses. When you use StepBP, the reading is obtained during step deflation.

Fluke Biomedical BP Pump/Bio-Tek Instruments BP Pump

Adult/Pediatric Mode

Simulator Setting	FastBP		StepBP	
	Expected Systolic	Expected Diastolic	Expected Systolic	Expected Diastolic
200/150	198	151	200	149
120/80	120	83	116	84
80/50	83	54	77	53

Neonate Mode

Simulator Setting	NeoBP	
	Expected Systolic	Expected Diastolic
60/30	56	26
35/15	31	12

Fluke Biomedical BP Pump/Bio-Tek Instruments BP Pump2

Adult/Pediatric Mode

Simulator Setting	FastBP		StepBP	
	Expected Systolic	Expected Diastolic	Expected Systolic	Expected Diastolic
200/150	202	157	201	146
120/80	118	80	116	82
80/50	86	51	77	55

Neonate Mode

Simulator Setting	NeoBP	
	Expected Systolic	Expected Diastolic
80/50	78	46
60/30	57	31
35/15	31	12

 Fluke Biomedical BP Pump/Dynatech Nevada Inc. CuffLink
Adult/Pediatric Mode

Simulator Setting	FastBP		StepBP	
	Expected Systolic	Expected Diastolic	Expected Systolic	Expected Diastolic
200/150	210	152	201	138
120/80	116	77	124	80
80/50	87	49	90	50

Clinical Dynamics Smart Arm

Adult/Pediatric Mode

Simulator Setting	FastBP		StepBP	
	Expected Systolic	Expected Diastolic	Expected Systolic	Expected Diastolic
200/150	192	152	194	136
120/80	124	79	122	80
80/50	85	42	80	49

Neonate Mode

Simulator Setting	NeoBP	
	Expected Systolic	Expected Diastolic
80/50	77	48
60/30	57	32
35/15	31	13

(This page intentionally left blank.)

Maintenance Test Checklist

Overview

Use the checklist on the following page to record the results of the Propaq MD unit maintenance tests, and keep it for your records.

Result of Check:

- o No action required
- o Minor problems corrected
- o Disposable supplies replaced
- o Major problems identified (unit out of service)

Additional Remarks

Serial Number: _____	Location: _____
Tester: _____	Signature: _____ Date: _____

ZOLL Propaq MD

Maintenance Test Checklist

OPERATIONAL TESTS

1.0 Physical Inspection

	Pass	Fail	N/A
1.1	0	0	
1.2	0	0	
1.3	0	0	
1.4	0	0	
1.5	0	0	
1.6	0	0	
1.7	0	0	
1.8	0	0	
1.9	0	0	0
1.10	0	0	0
1.11	0	0	0
1.12	0	0	
1.13	0	0	
1.14	0	0	
1.15	0	0	
1.16	0	0	
1.17	0	0	

2.1 Keypad Test

Pass	Fail
0	0

2.2 LED Test

Pass	Fail
0	0

2.3 LCD Test

Pass	Fail
0	0

2.4 RFU Indicator Test

Pass	Fail
0	0

2.5 Audio Test

Pass	Fail
0	0

2.6 Printer Test

Pass	Fail
0	0

2.7 Battery Test

Pass	Fail
0	0

2.8 Fan Test

Pass	Fail
0	0

2.9 USBTest

Pass	Fail
0	0

FUNCTIONAL TESTS

3.0 Leads Test

	Pass	Fail
3.1	0	0
3.2	0	0
3.3	0	0
3.4	0	0

4.0 Heart Rate Display Test

	Pass	Fail
4.1	0	0

5.0 Heart Rate Alarm Test

	Pass	Fail
5.1	0	0
5.2	0	0
5.5	0	0
5.7	0	0
5.9	0	0
5.11	0	0
5.12	0	0
5.13	0	0

6.0 Power Supply Test

	Pass	Fail
6.3.	0	0
6.6.	0	0

7.0 Leakage Current Test

Pass	Fail
0	0

8.0 Shock Test

	Pass	Fail
8.9	0	0
8.11	0	0
8.13	0	0
8.15	0	0
8.17	0	0
8.19	0	0
8.21	0	0
8.23	0	0
8.24	0	0
8.25	0	0

9.0 Advisory Test

	Pass	Fail
9.2	0	0
9.3	0	0
9.4	0	0
9.5	0	0
9.6	0	0

10.0 Synchronized Cardioversion Test

	Pass	Fail
10.2	0	0
10.4	0	0

11.0 Pacer Test

	Pass	Fail
11.6	0	0
11.8	0	0

12.0 Printer Test

	Pass	Fail
12.3	0	0

ZOLL Propaq MD

Maintenance Test Checklist

13.0 Treatment Report Test

	Pass	Fail
13.3	0	0
13.4	0	0
13.5	0	0
13.8	0	0
13.9	0	0
13.10	0	0

14.0 SpO₂ Test

	Pass	Fail	N/A
14.3	0	0	0
	0	0	0
14.4	0	0	0
	0	0	0
14.5	0	0	0
	0	0	0

15.0 SpO₂, SpCo, SpMet Test

	Pass	Fail	N/A
15.3	0	0	0
	0	0	
	0	0	
	0	0	
15.4	0	0	0
	0	0	
	0	0	
	0	0	
15.5	0	0	0
	0	0	
	0	0	
	0	0	
15.6	0	0	0
	0	0	
	0	0	
	0	0	

16.0 EtCO₂ Calibration

	Pass	Fail
16.6	0	0
	0	0

17.0 EtCO₂ Calibration Check

	Pass	Fail
17.5	0	0
17.6	0	0
17.7	0	0

18.0 EtCO₂ Test

	Pass	Fail
18.2	0	0
18.3	0	0

19.0 IBP Test

	Pass	Fail
19.4	0	0
	0	0
19.6	0	0

20.0 IBP Calibration Check

	Pass	Fail
20.8	0	0
20.9	0	0
20.15	0	0
20.16	0	0
20.22	0	0
20.23	0	0

21.0 NIBP Leak Test

	Pass	Fail
21.10	0	0

22.0 Deflation Test

	Pass	Fail
22.5	0	0

23.0 Inflation Test

	Pass	Fail
23.4	0	0

24.0 NIBP Test

	Pass	Fail
24.3	0	0
24.5	0	0
24.7	0	0

25.0 Temperature Test

	Pass	Fail
25.2	0	0

26.0 Wi-Fi Test (Optional)

	Pass	Fail
26.1	0	0
26.2	0	0
26.3	0	0
26.4	0	0
26.5	0	0
26.6	0	0
26.7	0	0
26.8	0	0

(This page intentionally left blank.)
