

Barrier-Free® Power Exam Table



Service and Parts Manual

Model Numbers:

625



FOR USE BY MIDMARK TRAINED TECHNICIANS ONLY

Table of Contents

General Info

GENERAL INFORMATION

Symbols	iii
Ordering Parts	iii
Serial Number Location	iii
Specifications	iv
Model Identification / Compliance Chart	vi
Scheduled Maintenance Cleaning Chart	vii

Section A

TROUBLESHOOTING

Troubleshooting Chart	A-2
Power to the Chair:	
120 V models	A-10
230 V models	A-11
Base Up / Down	A-12
Back Up / Down	A-14
Home Function	A-16
Drawer Heater System	A-18
Table Receptacle(s)	A-19
Scale Information Flow	A-20

Section B

TESTING

Foot / Hand Controls	B-2
Wireless Controls	B-4
Base Function Components	B-7
Back Function Components	B-11
Drawer Heater System	B-15
Table Calibration Procedure	B-20
Scale Calibration Procedure	B-21

Section C

ACCESS PROCEDURES

Manually Raising / Lowering Table	C-6
Removal / Installation:	
Cladding	C-2
Table Shrouds	C-3
Upholstery	C-7
Chair Arms / Brace	C-8
Top Cover	C-9

Section D

WIRING DIAGRAMS

625-001	D-2*
625-003	D-3*
625-004	D-4
625-005	D-5
625-006	D-6

Section E

EXPLODED VIEWS / PARTS LIST

625 (-001 /-003 /-004 /-005 / -006	E-2
--	-----

Digitally Linked Files

REPAIR PROCEDURES & FORMS

Base Actuator	003-2072-00
Back Actuator	003-2071-00
Main PC Board	003-2073-00
Scale / USB PC Boards	003-2454-00
LIN to VSM PC Board	003-2455-00
Wireless Basestation PC Board	003-2471-00
Color Selector	www.midmark.com

(*) Indicates multiple pages due to model / serial number break(s).

Symbols



DANGER

Indicates an imminently hazardous situation which **will** result in serious or fatal injury if not avoided.

This symbol is used only in the most extreme conditions.



WARNING

Indicates a potentially hazardous situation which **could** result in serious injury if not avoided.



Caution

Indicates a potentially hazardous situation which may result in minor or moderate injury if not avoided. It may also be used to alert against unsafe practices.



Equipment Alert

Indicates a potentially hazardous situation which could result in equipment damage if not avoided.

Note

Used for special instructions or additional information.

The symbols below may be used in this manual to represent the operational status of table functions and components.



Indicates the function / component is working properly. No action required.



Indicates the function / component is working, but a problem exists.



Indicates the function is not working at all, or that the component is faulty.

Ordering Parts

The following information is required when ordering parts:

- Serial number & model number
- Part number for desired part
(Refer to Section E: Exploded Views & Parts Lists)

Non-warranty part orders may be faxed to Midmark using the Fax Order Form in the back of this manual.

For warranty part orders, call Midmark's Technical Service Department with the required information.

Hours: 8:00 am to 5:00 p.m. EST (Monday thru Friday)

Phone: 1-800-Midmark (1-800-643-6275)

Serial Number Location

Model / Serial Number Label
Located on the Back Mounting Frame
(exact location may vary)

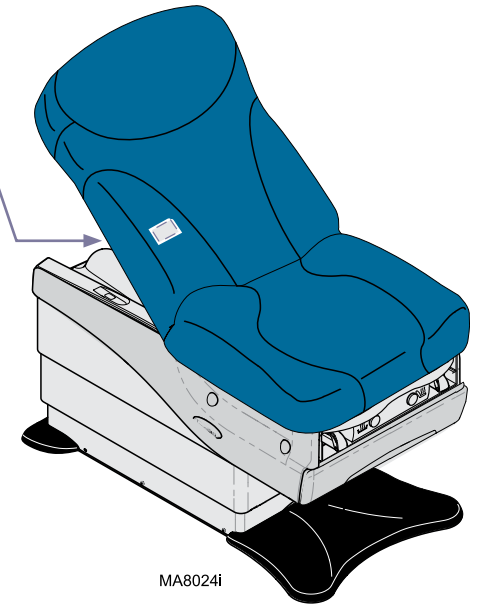

MA8024i

Specifications 625 (-001 /-003 /-005 /-006)

Range of Motion, Weights, Electrical Specifications

Specifications Chart	
Patient Weight (maximum):	650 lbs (295 kg)
Weight of Table:	
w/upholstery	470 lbs (213 kg)
w/packaging & skid (no uph.)	487 lbs (221 kg)
Uph. w/packaging (shipped separately)	45 lbs (20 kg)
Power Cord Length:	8 ft. (244 cm)
Electrical Requirements:	(See Regulatory Compliance Chart)
Foot / Hand Control Voltage:	14 VAC, SELV (Safety Extra Low Voltage)
Duplex Receptacle(s) (maximum load)	115 VAC, 5A, 50/60 Hz
Fuses:	
IEC inlet fuses (2)	6.3A, 250V, Type-T, 5 x 20 mm
F1 & F2 (on main PC board):	10A, 250V, Type-T, 5 x 20 mm
F3 (on main PC board):	160mA, 250V, Type-T, 5 x 20 mm
F4 (on main PC board)	6.3A, 250V, Type-T, 5 x 20 mm
Models w/ drawer heaters distribution board fuses (2)	800mA, 250V, Type-T, 5 x 20mm
Duty Cycle (Motor Run Time):	Intermittent Operation [30 seconds ON / 5 minutes OFF]
Receptacle(s) & Drawer Heater:	Continuous Operation
Classifications:	Class 1, Type B Applied Part
Protection against ingress of fluids:	IPX0 [Foot Control only: IPX1]

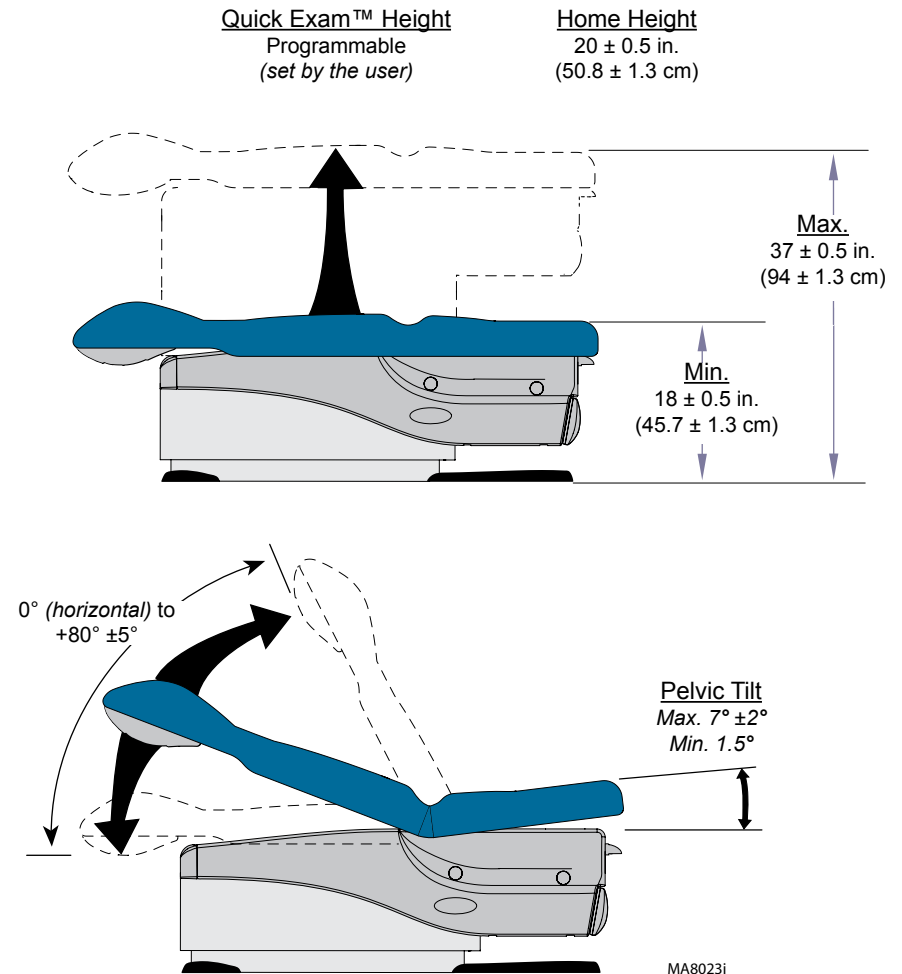

MA8023i



WARNING

Equipment not suitable for use in the presence of a flammable anesthetic mixture.

Specifications 625 (-004)

Range of Motion, Weights, Electrical Specifications

Specifications Chart	
Patient Weight (maximum):	650 lbs (295 kg)
Weight of Table:	
w/upholstery	475 lbs (216 kg)
w/packaging & skid (no uph.)	502 lbs (228 kg)
Uph. w/packaging (shipped separately)	45 lbs (20 kg)
Power Cord Length:	8 ft. (244 cm)
Electrical Requirements:	(See Regulatory Compliance Chart)
Foot / Hand Control Voltage:	14 VAC, SELV (Safety Extra Low Voltage)
Simplex Receptacles (maximum load)	115 VAC, 5A, 50/60 Hz
Fuses:	
IEC inlet fuses (2)	6.3A, 250V, Type-T, 5 x 20 mm
F1 & F2 (on main PC board):	10A, 250V, Type-T, 5 x 20 mm
F3 (on main PC board):	160mA, 250V, Type-T, 5 x 20 mm
F4 (on main PC board)	6.3A, 250V, Type-T, 5 x 20 mm
Models w/ drawer heaters distribution board fuses (2)	800mA, 250V, Type-T, 5 x 20mm
Duty Cycle (Motor Run Time):	Intermittent Operation [30 seconds ON / 5 minutes OFF]
Receptacles & Drawer Heater:	Continuous Operation
Classifications:	Class 1, Type B Applied Part
Protection against ingress of fluids:	IPX0 [Foot Control only: IPX1]

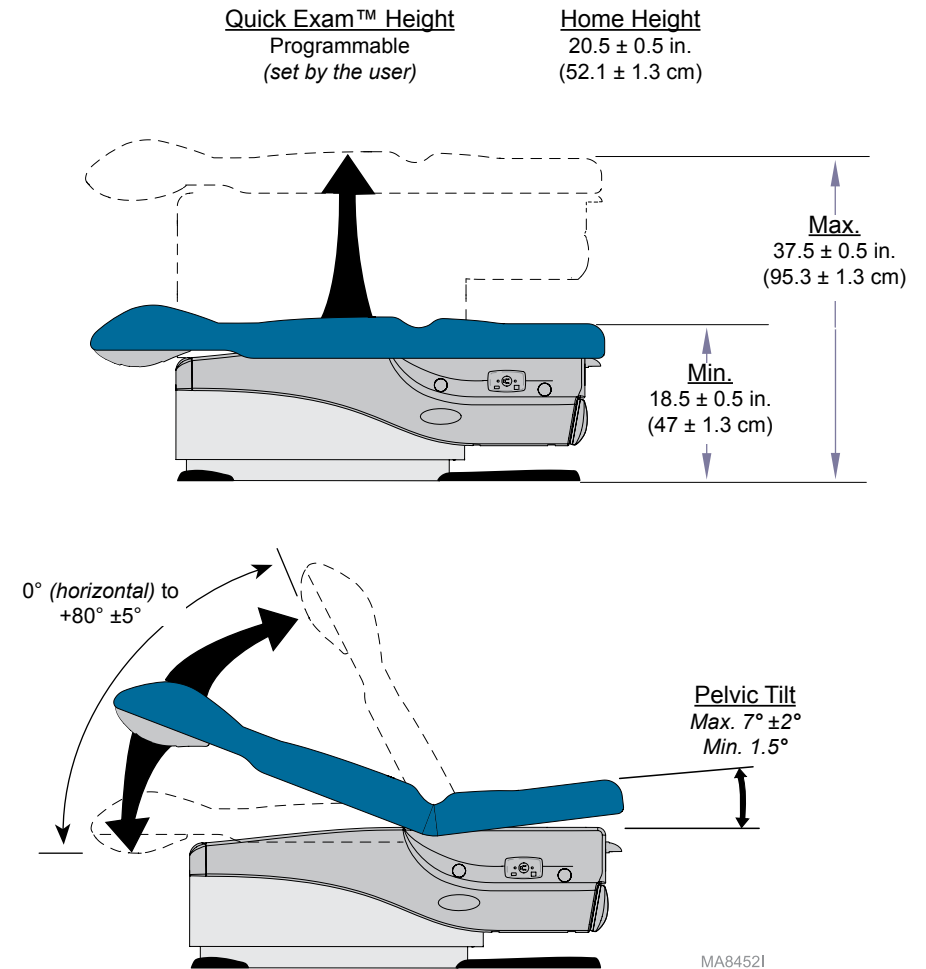

WARNING

Equipment not suitable for use in the presence of a flammable anesthetic mixture.

Model Identification / Compliance Chart

Fire Code Ratings:

All upholstery complies with California Bureau of Home Furnishing Technical Bulletin 117 and California Code of Regulations, Sect. 93120-93120.12, Title 17. Optional upholstery is available that complies with California Bureau of Home Furnishing Technical Bulletin 133.

Model	Description	Complies To:					Electrical Ratings:		
		UL 60601-1	CAN / CSA 22.2, #601.1-M90	EN 60601-1	EN 60601-1-2 (EMC)	NFPA 99	VAC +/- 10%	Amps	Cycles (Hz)
625-001	Two-function table (Base / Back), w/ receptacle(s), pelvic tilt, & drawer heater	•	•		•	•	115	12	50/60
625-003	Two-function table (Base / Back), w/ receptacle(s), pelvic tilt, drawer heater, & wire- less controls	•	•		•	•	115	12	50/60
625-004	Two-function table (Base / Back), w/ receptacles, pelvic tilt, drawer heater, wireless controls, IQscale™, and IQhub™	•	•		•	•	115	12	50/60
625-005	Two-function table (Base / Back), w/ pelvic tilt			•	•		230	4	50/60
625-006	Two-function table (Base / Back), w/ pelvic tilt, & drawer heater			•	•		230	4.5	50/60

Scheduled Maintenance / Cleaning Chart

Interval	Inspection / Service	Description
Weekly	Cleaning	Clean upholstery with appropriate diluted bleach solution 10:1 (water: bleach)
		Wipe painted metal & plastic surfaces with a clean soft cloth and mild cleaner. (Note: Periodic application of common furniture wax will ease cleaning and maintain the luster of the surfaces).
	Obvious Damage	Visually inspect components for damage that could result in unsafe operation.
Semi-Annually	Mechanical Operation	Check all mechanical functions using the foot control. Repeat using the hand control.
		Table shrouds should move smoothly & quietly when base is raised & lowered. <i>(NOTE: There are plastic glides on the shroud tabs, Missing glides may result in noisy operation.)</i>
	Labels / Decals	Replace any missing or illegible labels.
	Lubrication	Lubricate back hinge with light machine oil.
		Lubricate footrest slide with household furniture wax.
	Hardware	All fasteners must be present and fastened securely.
	Electrical System	Inspect power cord and all wiring for damage.
		Be sure all electrical connections are tight.
	Stirrups	Check that stirrups extend easily, and lock securely into each lateral position.
Scale	Verify the scale is measuring accurately using a reference weight of known value.	
Date of Service:		Model Number:
Location:		Serial Number:
Service Technician:		Notes:

Section A

Troubleshooting

Troubleshooting Chart	A-2
Power to the Chair	
120 V models	A-10
230 V models	A-11
Base Up / Down	A-12
Back Up / Down	A-14
Home Function	A-16
Drawer Heater System	A-18
Table Receptacle(s)	A-19

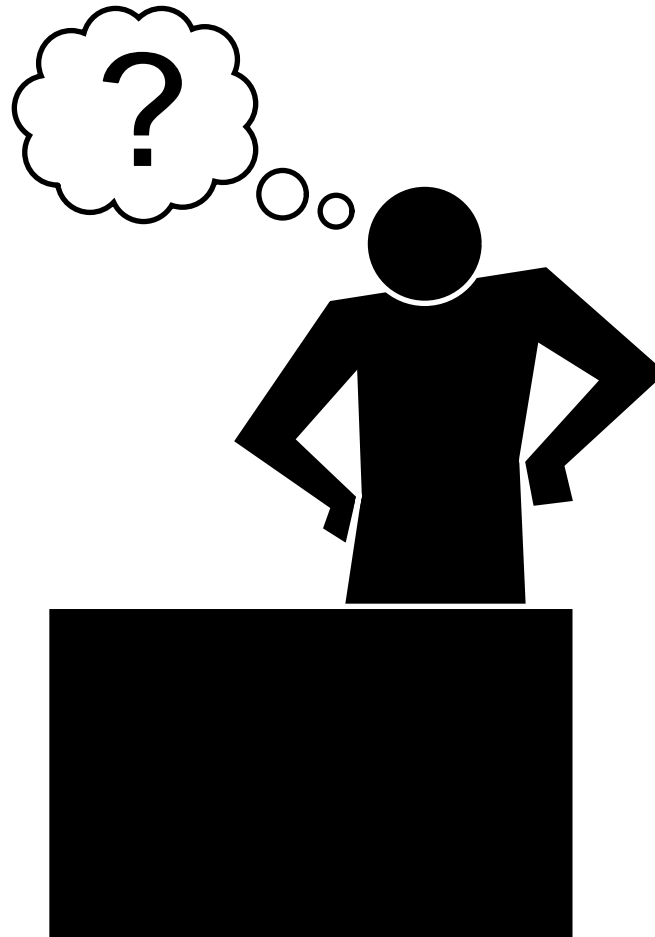

Quick Reference for 625 Scale Table (also refer to 625 Troubleshooting Chart section):

If below information does not resolve the issue, then contact technical service at 1-800-MIDMARK (643-6275).

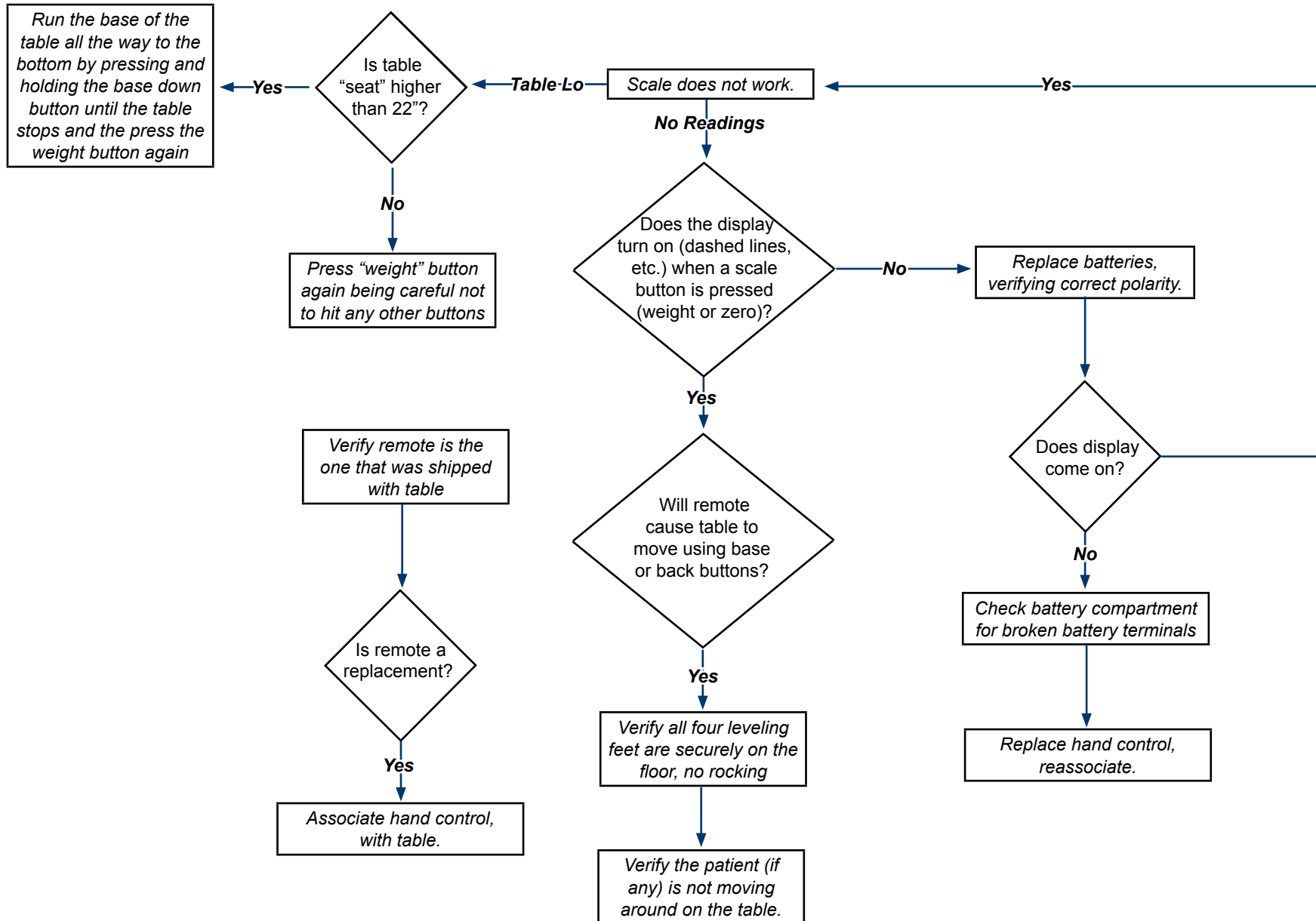

Troubleshooting Chart

Problem	Symptom	Probable Cause	Check	Correction
No functions will operate.	All functions inoperable.	Facility supply voltage	Power cord connections & facility circuit breaker.	Secure power cord connections. Reset circuit breaker if necessary.
		Main PC board fuse(s) blown	Test F1, F2, F3, & F4 fuses	Refer to: Section D - Wiring Diagrams
		Loose wire connections	Wire connections between power inlet and main PC board.	Secure loose wire connections.
		Wireless controls (if applicable)	Refer to: Section B - Wireless Controls	Perform wireless controls test.
		Overtravel limit switch (Later models only)	Perform limit switch test Section B - Limit Switch Test	Replace faulty limit switch.
Base function not operating properly.	No Base Up or Base Down.	Loose wire connections	Wire connections (esp. Foot/Hand control(s) and base up/down limit switches).	Secure loose wire connections.
		Main PC board fuse(s) blown	Test F1, F2, F3, & F4 fuses	Refer to: Section D - Wiring Diagrams
		Foot / Hand control (refer to: Wireless Controls if applicable)	Perform Foot / Hand control test.	Refer to: Section B - Foot / Hand Controls
		Base actuator / PC board	Perform PC board tests.	Refer to: Section B - PC Board Test
	Table stops and beeps	Patient weight exceeded 650 lbs	If patient weight exceeded the 650 lb. weight limit.	Inform staff that max. patient weight is 650 lbs.
	No Base Up / Base Down OK	Loose wire connections	Wire connections (esp. Foot/Hand control(s) and base up limit switch).	Secure loose wire connections.
		Foot / Hand Control (refer to: Wireless Controls if applicable)	Perform Foot / Hand control test.	Refer to: Section B - Foot / Hand Controls
		Base Up limit switch	Perform limit switch test Section B - Limit Switch Test	Replace faulty limit switch.
		Base actuator / PC board	Perform PC board test.	Refer to: Section B - PC Board Test
	No Base Down / Base Up OK	Loose wire connections	Wire connections (esp. Foot/Hand control(s) and base down limit switch).	Secure loose wire connections.
		Foot / Hand Control (refer to: Wireless Controls if applicable)	Perform Foot / Hand control test.	Refer to: Section B - Foot / Hand Controls
		Base Down limit switch	Perform limit switch test Section B - Limit Switch Test	Replace faulty limit switch.
		Base actuator / PC board	Perform PC board test.	Refer to: Section B - PC Board Test

Troubleshooting Chart

Problem	Symptom	Probable Cause	Check	Correction
Base function not operating properly. - continued	Base Up / Down noisy, grinding or squeaking.	Actuator threads dry	Actuator threads.	Clean and lubricate base actuator threads with Lithium grease.
		Debris on Base Slides	For any debris on base slides.	Remove any debris from base slides. <i>Note: Do not lubricate base slides.</i>
		Base Actuator	Run table up and down, if squeaking or grinding continue check base actuator.	Replace base actuator.
	Table Up / Down - Table drifts down.	Foot / Hand Control (<i>refer to: Wireless Controls if applicable</i>)	Run table up, then unplug power cord. If drifting stops, perform Foot / Hand control test.	Refer to: Section B - Foot / Hand control
		Base Actuator	Run table up, then unplug power cord. If drifting continues, check base actuator.	Replace base actuator.
	Back function not operating properly.	No Back Up or Back Down.	Loose wire connections	Wire connections (esp. Foot/Hand control(s) and back up/down limit switches.)
Main PC board fuse(s) blown			Test F1, F2, F3, & F4 fuses	Section D - Wiring Diagrams
Foot / Hand control (<i>refer to: Wireless Controls if applicable</i>)			Perform Foot / Hand control test.	Refer to: Section B - Foot / Hand Controls
Back actuator / PC board			Perform PC board test.	Refer to: Section B - PC Board Test
Table stops and beeps.		Patient weight exceeded 650 lbs	If patient weight exceeded the 650 lb. weight limit.	Inform staff that max. patient weight is 650 lbs.
No Back Up / Back Down OK.		Loose wire connections	Wire connections (esp. Foot/Hand control(s) and back up limit switch.)	Secure loose wire connections.
		Foot / Hand Control (<i>refer to: Wireless Controls if applicable</i>)	Perform Foot / Hand control test.	Refer to: Section B - Foot / Hand Controls
		Back Up Limit Switch	Perform limit switch test. Section B - Limit Switch Test	Replace faulty limit switch.
		Back actuator / PC board	Perform PC board test.	Refer to: Section B - PC Board Test

Troubleshooting Chart

Problem	Symptom	Probable Cause	Check	Correction
Back function not operating properly. - continued	No Back Down / Back Up OK.	Loose wire connections	Wire connections (esp. Foot/Hand control(s) and back down limit switch).	Secure loose wire connections.
		Foot / Hand Control (refer to: Wireless Controls if applicable)	Perform Foot / Hand control test.	Refer to: Section B - Foot / Hand Controls
		Back Down limit switch	Perform limit switch test Section B - Limit Switch Test .	Replace faulty limit switch.
		Back actuator / PC board	Perform PC board test.	Refer to: Section B - PC Board Test
	Back Up / Down - Back drifts down.	Foot / Hand Control (refer to: Wireless Controls if applicable)	Run back up, then unplug power cord. If drifting stops, perform Foot / Hand control test.	Refer to: Section B - Foot / Hand Controls
		Back Actuator	Run back up, then unplug power cord. If drifting continues, check back actuator.	Replace back actuator
Home not functioning properly.	No Home / Base Down OK.	Loose wire connections.	Wire connections (esp. Foot/Hand control(s) and Home limit switches).	Secure loose wire connections.
		Foot / Hand Control (refer to: Wireless Controls if applicable)	Perform Foot / Hand control test.	Refer to: Section B - Foot / Hand Controls
		Home Limit Switch(es)	Perform Limit Switch test. Refer to: Section B - Limit Switch Test	Replace faulty Limit Switch.
Quick Exam® not functioning properly.	Quick Exam® function inoperable.	Quick Exam® function not programmed.	If Quick Exam® function was properly programmed.	Refer to: Quick Exam® Operation in User Guide.
		Loose wire connections.	Wire connections (esp. Foot/Hand control(s) and Travel limit switches).	Secure loose wire connections.
		Foot / Hand Control (refer to: Wireless Controls if applicable)	Perform Foot / Hand control test.	Refer to: Section B - Foot / Hand Controls
		Travel Limit Switch(es)	Perform Limit Switch test. Refer to: Section B - Limit Switch Test	Replace faulty Limit Switch.

Troubleshooting Chart

Problem	Symptom	Probable Cause	Check	Correction
Table Receptacle(s) malfunctioning.	No power at table receptacle(s) All other functions work.	Circuit breaker	If circuit breaker is tripped.	Lift seat section to access circuit breaker(s), press to reset.
		Loose wire connection	Check wire connections between table receptacle and power cord.	Secure loose wire connections.
		Blown isolation transformer fuse(s) at IEC inlet	Test fuses at IEC inlet.	Refer to: Section D - Wiring Diagrams
		Isolation Transformer	Output voltage at isolation transformer.	Replace faulty isolation transformer.
		Table Receptacle	Voltage at receptacle.	Replace faulty receptacle.
Wireless Controls malfunctioning.	When any control button is pressed, that controller sounds a single "beep". (All functions operate)	Low battery	Refer to: Section B - Wireless Controls	Replace batteries. (size: AA)
		Faulty PC board in controller	Refer to: Section B - Wireless Controls	Replace controller PC board.
	When any control button is pressed, nothing happens. (No "beeps", no movement, ect.)	Controller not associated to table.	Refer to: Section B - Wireless Controls	Perform Association Procedure.
		Wireless controls component malfunction.	Refer to: Section B - Wireless Controls	Replace malfunctioning component.
Drawer Heater malfunctioning.	Drawer Heater does not warm up Heater Switch does not illuminate.	Loose wire connections.	Check wire connections between heater switch and power cord.	Secure loose wire connections.
		Blown fuse(s) on distribution board.	Test fuses on distribution board.	Refer to: Section D - Wiring Diagrams
		Drawer heater switch.	Test drawer heater switch. Refer to: Section B - Drawer Heater Switch Test	Replace drawer heater switch.
	Drawer Heater does not warm up Heater Switch-OK (<i>illuminates</i>).	Loose wire connections.	Check wire connections between heater switch and heater plate.	Secure loose wire connections.
		Drawer Heater Plate.	Test drawer heater plate. Refer to: Section B - Drawer Heater Plate Test	Replace drawer heater plate.
	Drawer Heater-OK Heater Switch does <u>not</u> illuminate.	Drawer Heater Switch.	Refer to: Section B - Drawer Heater Switch replacement.	Replace drawer heater switch.

Troubleshooting Chart (625-004)

Problem	Symptom	Probable Cause	Check	Correction
Digital Scale is malfunctioning.	Nothing is displayed on the digital display. Table functions OK.	Ten second scale time out feature activated.	Press Zero button to reactivate display.	Inform operator of the ten second time out feature.
		Faulty PC board in controller	Replace PC Board with known working PC Board.	Replace controller PC board.
	The measured weight of patient is inaccurate or the display scrolls.	Scale is not zeroed.	Check if operator failed to zero scale before seating patient.	Refer to: Scale Operation in Users Guide.
		The patient's feet are making contact with the floor after weight button has been pressed..	Check that the patient is properly seated.	Refer to: Scale Operation in Users Guide.
			Check if stop button was depressed while table was automatically raising.	Refer to: Scale Operation in Users Guide.
		Obstruction under or around table base.	Check for any obstruction under or around table.	Remove obstruction.
		Table not level.	Using bubble level supplied with table, check each corner of table base for level.	Refer to: Leveling Instructions in Installation Guide.
		Display on hand control scrolls without displaying weight.	Hand control not associated with table. (<i>No table functions</i>).	Perform association procedure.
	Wire connection to external antenna loose or broken.		Check wire connections to External Antenna.	Refer to: Wireless Controls.
	Digital Display works, but measured weight stays at zero.	Scale calibration lost.	Verify scale is measuring accurately using a reference weight of known value.	Refer to: Scale Calibration Procedure.
		Loose wire connection.	Check wire connections from each load cell and scale control board.	Secure loose wire connection.
			Check wire connections between Scale PC Board and LIN to Scale PC Board.	Secure loose wire connection.
			Check wire connections between 625 to USB board and LIN to Scale board.	Secure loose wire connection.
		Defective Scale PC Board.	Replace Scale PC Board with known working Scale PC Board.	Refer to: Scale / USB PC Boards Replacement Instructions.
		Defective LIN to Scale PC Board.	Replace LIN to Scale PC Board with known working LIN to Scale PC Board.	Refer to: Scale / USB PC Boards Replacement Instructions.

Troubleshooting Chart (625-004)

Problem	Symptom	Probable Cause	Check	Correction
No function with hand or foot control	When depressing <u>wired or wire-</u> <u>less</u> hand or foot control, no base or back up/down function (green light D12 on PC Board <u>not</u> illumi- nated).	Supply voltage.	Facility circuit breaker.	Reset circuit breaker..
		Power cord inlet (IEC)	Power cord.	Ensure inserted securely into inlet.
			Export Only: IEC inlet trans- former fuses (6.3A, 250 V Slo-Blo)	Replace fuses.
		Main PC Board primary fuses (F1 and F2)	Continuity of fuses (10 A, 250 V Slo-Blo)	Replace blown fuse
		Main PC board transformer fuse (F3)	Continuity on fuse (160 mA, 250V Slo-Blo)	Replace blown fuse.
		Loose wire connections	Wire connections between power inlet and PC board.	Check for correct line voltage at board
			Wire connections on main PC Board	Secure loose wire connection to back/base functions. Ensure har- ness wires are staggered properly to prevent any possible harness disconnection from board or from actuator.
		Overtravel limit switch (only on models with serial numbers from V96852 to present)	Perform limit switch test (untripped = less than 5 ohm; tripped = OL)	Replace faulty limit switch.

Troubleshooting Chart (625-004)

Problem	Symptom	Probable Cause	Check	Correction
No function with hand or foot control	When depressing <u>wired</u> hand or foot control, no base or back up/down function (green light D12 on PC Board illuminated).	Hand control	Coil cord plugged properly into receptacle on table	Properly plug coil cord into receptacle
			Break in coil cord	Check for breaks. Replace coil cord as needed.
			Inlet malfunctioning	Plug hand control into second port to check for functionality. Replace defective port.
			Cord running from inlet to PC Board disconnected or broken.	Check cord for proper installation. Replace suspect cord with known working cord or perform continuity check on cord. Refer to: Section B - Foot / Hand Controls
			Main PC Board is malfunctioning	Refer to: Section B -PC Board Test
		Main PC Board base and back motor fuse (F4)	Continuity on fuse (6.3A, 250 V Slo-Blo)	If board is Version 1.5.X or below, then replace main PC Board. If board is Version 1.6.X or above, then replace fuse. Replace all 625 boards if fuse blown with serial number before V1309272. Replace fuse only with serial number after V1365847.
	Wire connections on main PC Board	Secure loose wire connection to back/base functions. Ensure harness wires are staggered properly to prevent any possible harness disconnection from board or from actuator.		
No function with hand or foot control. Unit gives audible PC Board tones when unplugged and plugged back in.	When depressing <u>wireless</u> hand or foot control, no base or back up/down function (green light D12 on PC Board illuminated).	Wireless hand and/or foot control	Batteries (controller will sound a single beep if batteries are low).	Replace batteries (size AA).
			Association of controller to table	Perform Association Procedure . If association does not work, then refer to: Wireless Controls - Isolating a Malfunction
		Main PC Board base and back motor fuse (F4)	Continuity on fuse (6.3A, 250 V Slo-Blo)	If board is Version 1.5.X or below, then replace main PC Board. If board is Version 1.6.X or above, then replace fuse.
			Wire connections on main PC Board	Secure loose wire connection(s).
Receptacle	Power cord inlet (IEC)		Continuity of isolation transformer fuses (6.3A, 250 V Slo-Blo).	Replace fuses.

Power to the Chair (120 V models)

This illustration shows only the components that affect ALL TABLE FUNCTIONS.
A detailed description of current flow also appears below.

No functions will operateA-3

Facility Supply Voltage

With the chair's power cord properly connected, facility supply voltage (115 VAC) is supplied thru the cord to the main PC board.

Note

The two external fuses at the power cord (IEC) inlet do **not** affect Base or Back functions. These fuses affect the table receptacle only.

Overtravel Limit Switch (Later models only)

Disrupts power to main PC board if table is over extended.

Main PC Board

When proper voltage is supplied to the PC board, the power indicator light (on PC board) is illuminated. Circuitry on the PC board provides the required voltage to power all of the table's components: *hand / foot controls, actuators, limit switches.*

Fuses

The fuses on the PC board affect the following functions:

F1 / F2 / F3 / F4: *Base and Back functions*

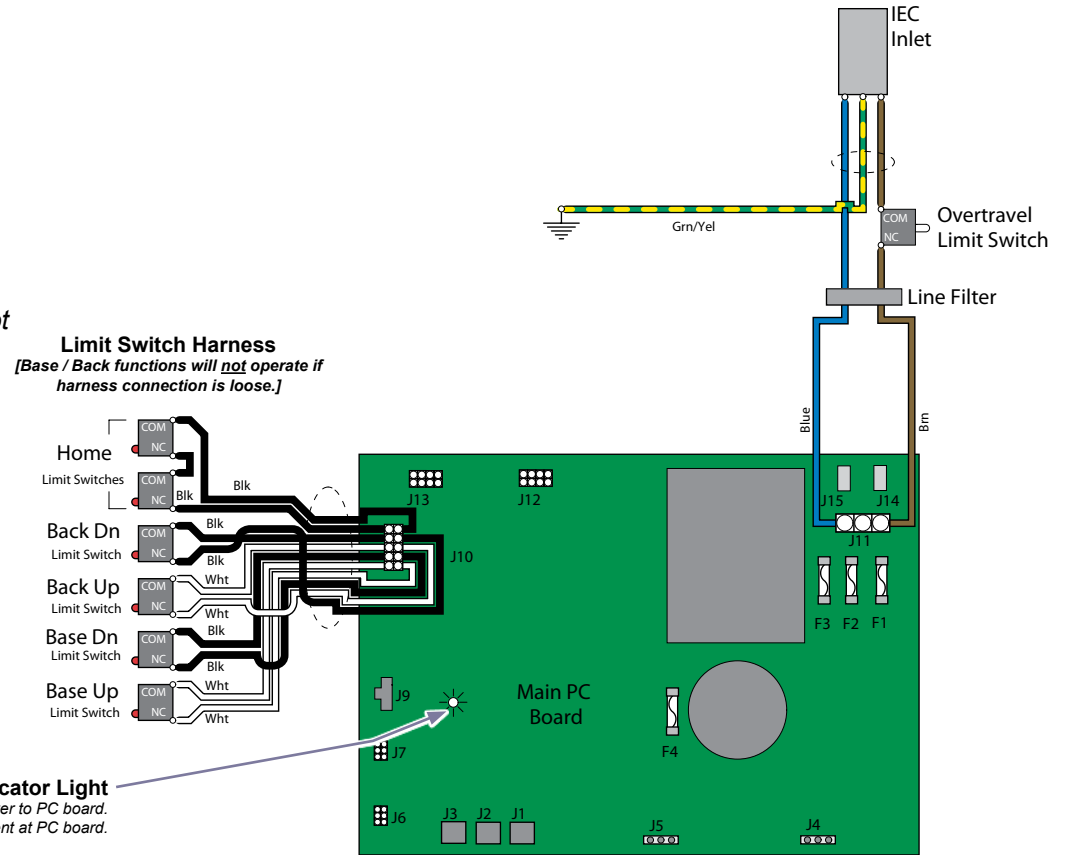

MA81171

Models:	625 (-001 & -003)
Serial Numbers:	<i>all</i>

Power to the Chair (230 V models)

No functions will operateA-3

This illustration shows only the components that affect ALL TABLE FUNCTIONS.
A detailed description of current flow also appears below.

Facility Supply Voltage

With the chair's power cord properly connected, facility supply voltage (230 VAC) is supplied thru the two power cord inlet fuses to the export transformer.

Export Transformer

The export transformer reduces the line voltage and supplies 120V to the main PC board.

Overtravel Limit Switch (Later models only)

Disrupts power to main PC board if table is over extended.

Main PC Board

When proper voltage is supplied to the PC board, the power indicator light (on PC board) is illuminated. Circuitry on the PC board provides the required voltage to power all of the table's components: *actuators, hand / foot controls, limit switches, etc.*

Fuses

The fuses on the PC board affect the following functions:

F1 / F2 / F3 / F4: *Base and Back functions*

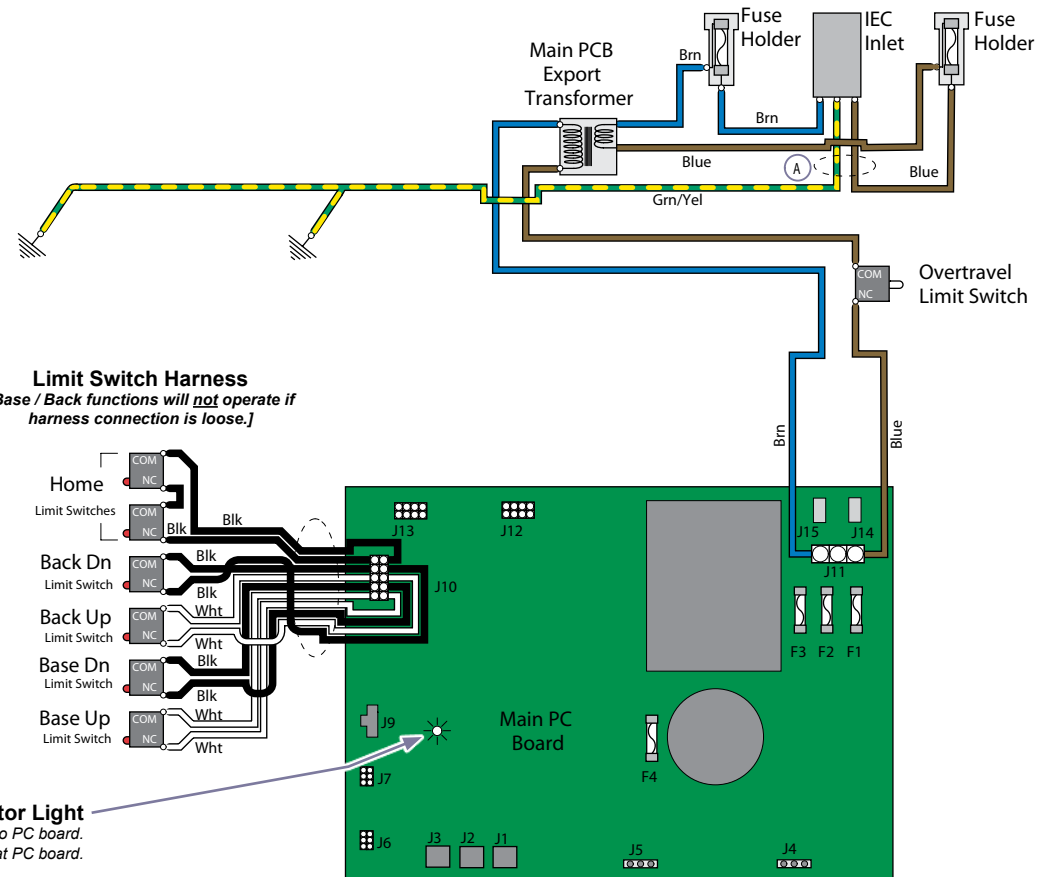

MA8119i

Models:	625 (-005 & -006)
Serial Numbers:	<i>all</i>

Base UP / DOWN Function

This illustration shows only the components that affect the Base UP / DOWN function. .
Refer to the following page for a detailed description of current flow during this function.

No Base Up or Base Down.....	A-3
Table Stops and Beeps	A-3
No Base Up. Base Down - OK	A-3
No Base Down. Base Up - OK	A-3
Noisy Operation.....	A-4
Base Up / Down -Table Drifts	A-4

Note: 230 VAC models only

Line voltage (230 VAC) is supplied thru two fuses (located by the IEC inlet) to a transformer that reduces the line voltage to 115 VAC before it reaches the PC Board.

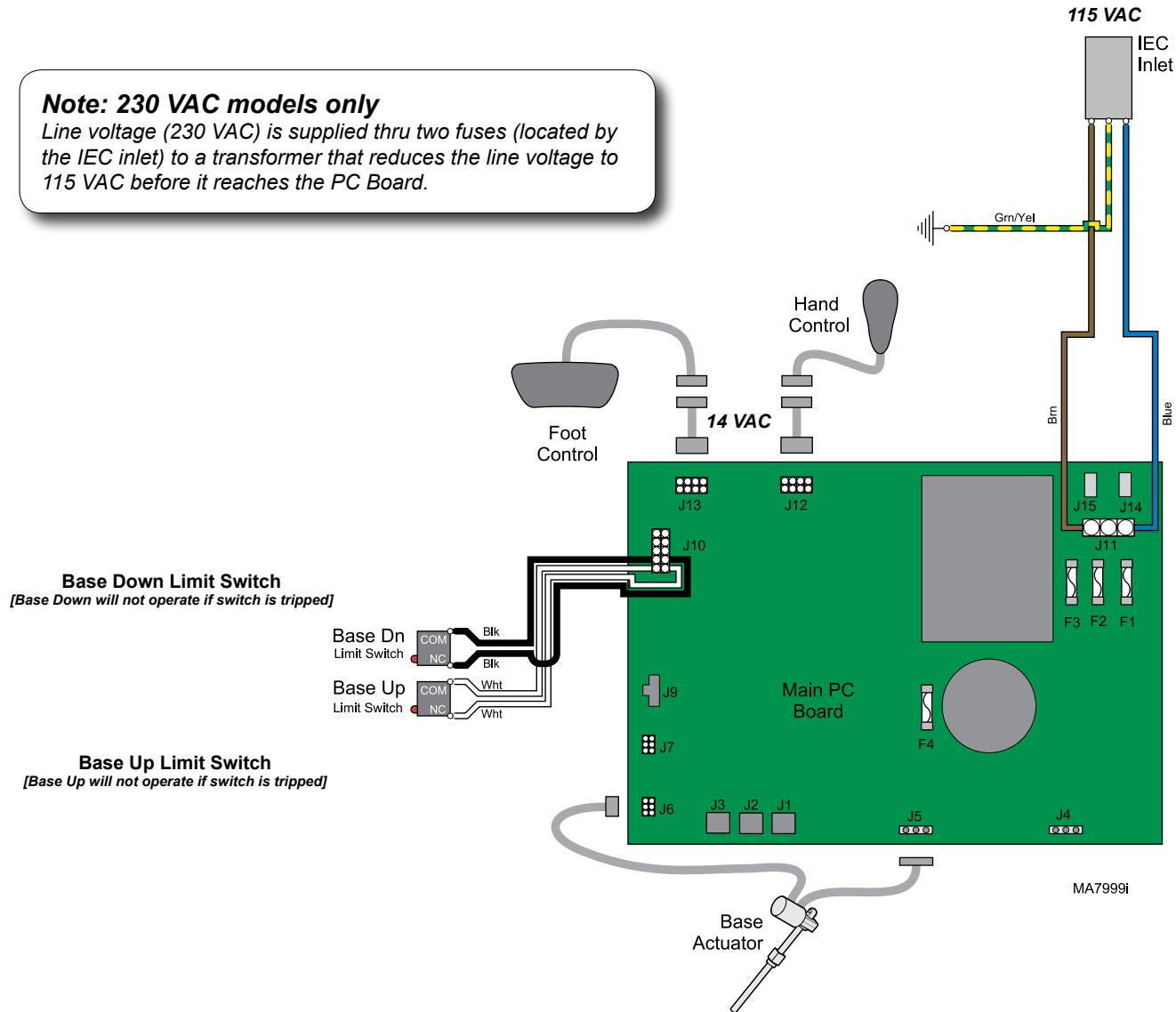

Models:	625
Serial Numbers:	<i>all</i>

Base UP / DOWN Function

Note

On 230 VAC models, line voltage (230VAC) is supplied thru two fuses (located by IEC inlet) to a transformer that reduces the line voltage to 115 VAC before it reaches the PC board.

Power to Foot / Hand Control

115 VAC is supplied thru the two primary fuses (F1 & F2) to the transformer on the PC board. [F3 fuse protects the transformer].

The transformer reduces the line voltage and supplies 14 VAC to the foot / hand control.

Base Up Operation

Note

If the Base Up limit switch is tripped (open), the Base Up function will not operate.

When the Base Up function is activated, current (14 VAC) flows thru the UP function foot switch (N.O.), then back to the PC board. Circuitry on the PC Board energizes the base motor. [F4 fuse protects the base motor].

When the base function is energized, current flows to the actuator motor. When current flows to the actuator, the actuator motor runs and raises the table.

Actuator motor runs until:

1. Foot / Hand control button is released.
2. Base Up limit switch is tripped.
3. Fuse(s) opens (blows).
[Primary, Base Motor, Transformer fuse]
4. Over current condition is detected.

Base Down Operation

Note

If the Base Down limit switch is tripped (open), the Base Down function will not operate.

When the Base Down function is activated, current (14 VAC) flows thru the DOWN function foot switch (N.O.), then back to the PC board. Circuitry on the PC Board energizes the base motor. [F4 fuse protects the base motor].

When the base function is energized, current flows to the actuator motor. When current flows to the actuator, the actuator motor runs and lowers the table.

Actuator motor runs until:

1. Foot / hand control button is released.
2. Base Down limit switch is tripped.
3. Fuse(s) opens (blows).
[Primary, Base Motor, Transformer fuse]
4. Over current condition is detected.



Equipment Alert

If an over current condition* is detected the PC board will “beep” and all power functions will be disabled. Release the function button, remove load, then retry function.

*(weight limit exceeded, mechanical binding, etc),

Models:	625
Serial Numbers:	<i>all</i>

Back UP / DOWN Function

This illustration shows only the components that affect the Back UP / DOWN function. .
Refer to the following page for a detailed description of current flow during this function.

No Back Up or Back Down.....	A-4
Table Stops and Beeps	A-4
No Back Up. Back Down - OK.....	A-4
No Back Down. Back Up - OK.....	A-5
Back Up / Down - Back Drifts.....	A-5

Note: 230 VAC models only
Line voltage (230 VAC) is supplied thru two fuses (located by the IEC inlet) to a transformer that reduces the line voltage to 115 VAC before it reaches the PC Board.

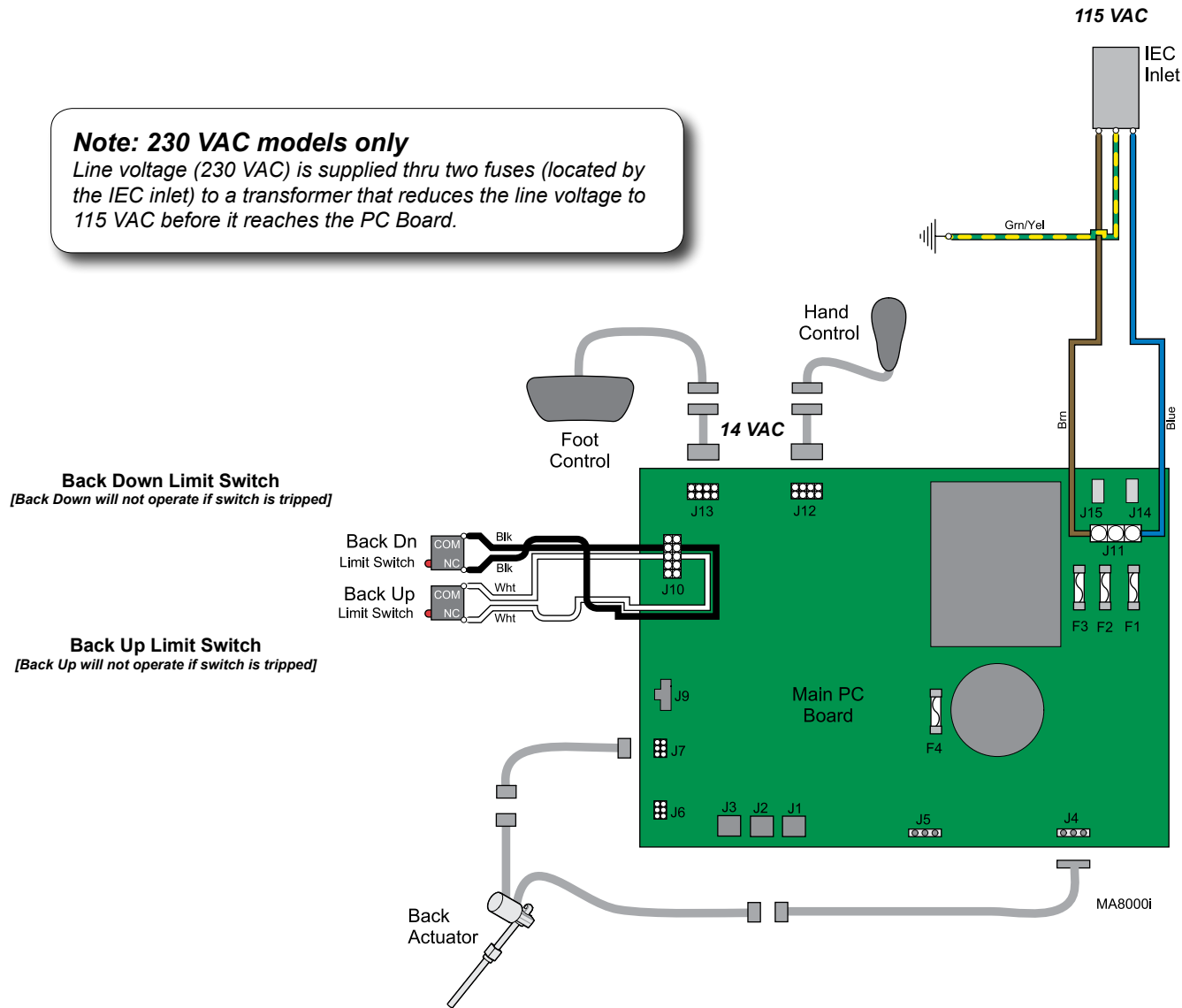

Models:	625	
Serial Numbers:	<i>all</i>	

Back UP / DOWN Function

Note

On 230 VAC models, line voltage (230VAC) is supplied thru two fuses (located by IEC inlet) to a transformer that reduces the line voltage to 115 VAC before it reaches the PC board.

Power to Foot / Hand Control

115 VAC is supplied thru the two primary fuses (F1 & F2) to the transformer on the PC board. [F3 fuse protects the transformer].

The transformer reduces the line voltage and supplies 14 VAC to the foot / hand control.

Back Up Operation

Note

If the Back Up limit switch is tripped (open), the Back Up function will not operate.

When the Back Up function is activated, current (14 VAC) flows thru the UP function foot switch (N.O.), then back to the PC board. Circuitry on the PC Board energizes the back motor. [F4 fuse protects the back motor].

When the back function is energized, current flows to the actuator motor. When current flows to the actuator, the actuator motor runs and raises the back section.

Actuator motor runs until:

1. Foot / Hand control button is released.
2. Back Up limit switch is tripped.
3. Fuse(s) opens (blows).
[Primary, Back Motor, Transformer fuse]
4. Over current condition is detected.

Back Down Operation

Note

If the Back Down limit switch is tripped (open), the Back Down function will not operate.

When the Back Down function is activated, current (14 VAC) flows thru the DOWN function foot switch (N.O.), then back to the PC board. Circuitry on the PC Board energizes the back motor. [F4 fuse protects the back motor].

When the back function is energized, current flows to the actuator motor. When current flows to the actuator, the actuator motor runs and lowers the back section.

Actuator motor runs until:

1. Foot / Hand control button is released.
2. Back Down limit switch is tripped.
3. Fuse(s) opens (blows).
[Primary, Back Motor, Transformer fuse]
4. Over current condition is detected.



Equipment Alert

If an over current condition* is detected the PC board will "beep" and all power functions will be disabled. Release the function button, remove load, then retry function.

*(weight limit exceeded, mechanical binding, etc).

Models:	625
Serial Numbers:	<i>all</i>

Home Function

No Home. Base Down - OK.....A-5

This illustration shows only the components that affect the Home function. .
 Refer to the following page for a detailed description of current flow during this function.

Note: 230 VAC models only
 Line voltage (230 VAC) is supplied thru two fuses (located by the IEC inlet) to a transformer that reduces the line voltage to 115 VAC before it reaches the PC Board.

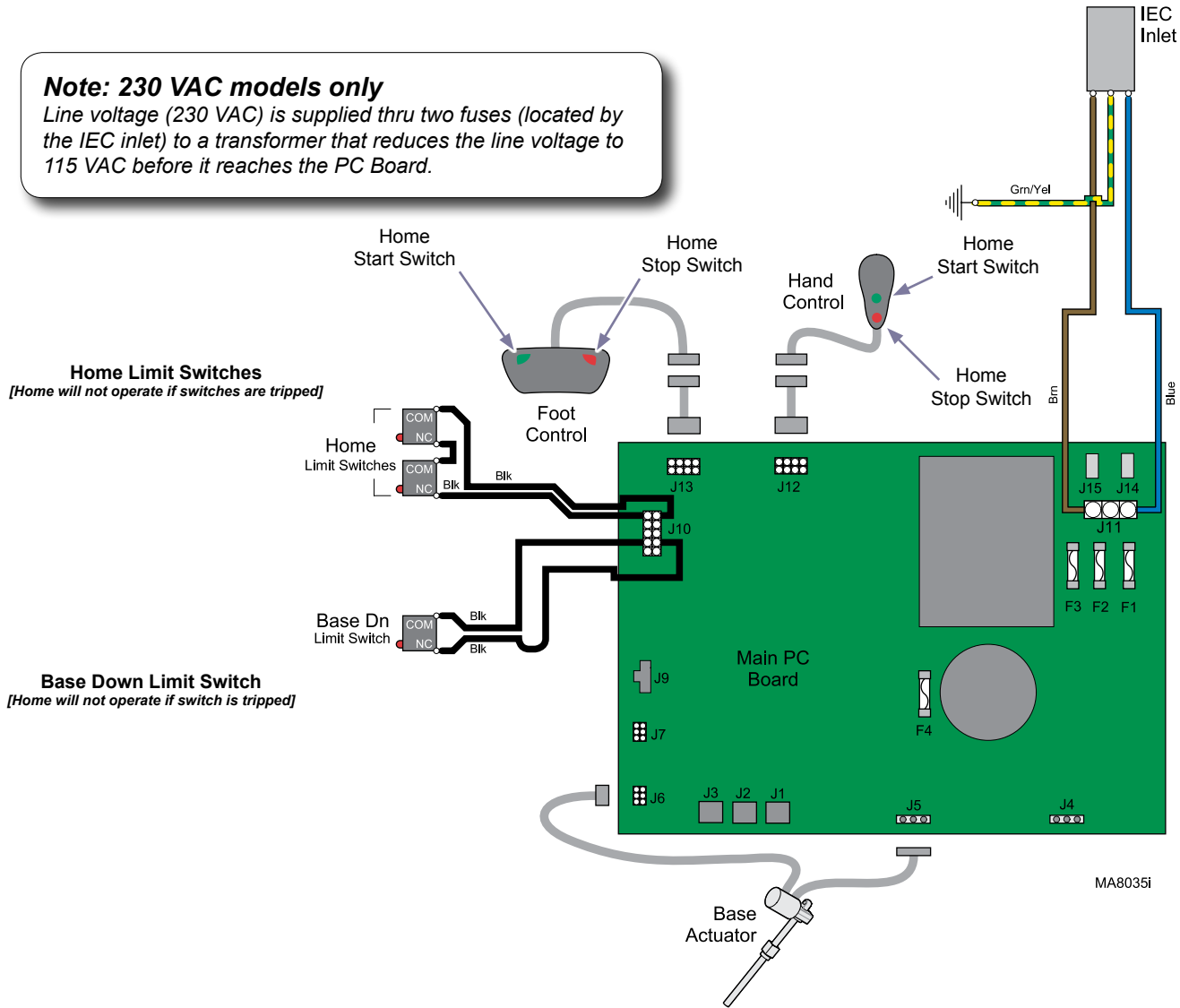

Models:	625
Serial Numbers:	<i>all</i>

Home Function

Note

On 230 VAC models, line voltage (230VAC) is supplied thru two fuses (located by IEC inlet) to a transformer that reduces the line voltage to 115 VAC before it reaches the PC board.

Power to Foot / Hand Control

115 VAC is supplied thru the two primary fuses (F1 & F2) to the transformer on the PC board. [F3 fuse protects the transformer].

The transformer reduces the line voltage and supplies 14 VAC to the foot / hand control.

Home Operation

Note

If either of the Home limit switches or the Base Down limit switch are tripped (open), the Home function will not operate.

When the Home function is activated, current (14VAC) flows thru the Home foot switch, (N.O.), then back to the PC Board. Circuitry on the PC Board energizes the base motor. [F4 fuse protects the base motor].

When the Home function is energized, current flows to the base motor. When current flows to the actuator, the actuator motor runs and lowers the table.

When voltage flows to the actuator, the actuator motor runs lowering the table.

Actuator motor runs until:

1. Stop button is depressed.
2. Home limit switch(es) is tripped.
3. *Base Down limit switch is tripped.*
4. *Fuse(s) opens (blows).*
[Primary, Base Motor, Transformer fuse]
5. Over current condition is detected.



Equipment Alert

If an over current condition* is detected the PC board will “beep” and all power functions will be disabled. Release the function button, remove load, then retry function.

*(weight limit exceeded, mechanical binding, etc).

Models:	625	
Serial Numbers:	<i>all</i>	

Drawer Heater System (optional)

This illustration shows only the components that affect the Drawer Heater System. A detailed description of current flow during this function also appears below.

*Drawer Heater Does Not Warm up:
Switch Does Not Illuminate.....A-5
Switch Illuminates.....A-5
Drawer Heater Works - Properly
Switch Does Not Illuminate.....A-5*

Note: 230 VAC models only

Line voltage (230 VAC) is supplied thru two fuses (located by the IEC inlet) to a transformer that reduces the line voltage to 115 VAC before it reaches the PC Board.

Drawer Heater Operation

115 VAC is supplied directly to the Drawer Heater switch thru two fuses on the Distribution Board. [Voltage bypasses the Main PC Board].

When the drawer heater switch is turned ON, current flows to the heater plate. When the heater plate is energized, it warms the contents of the drawer.

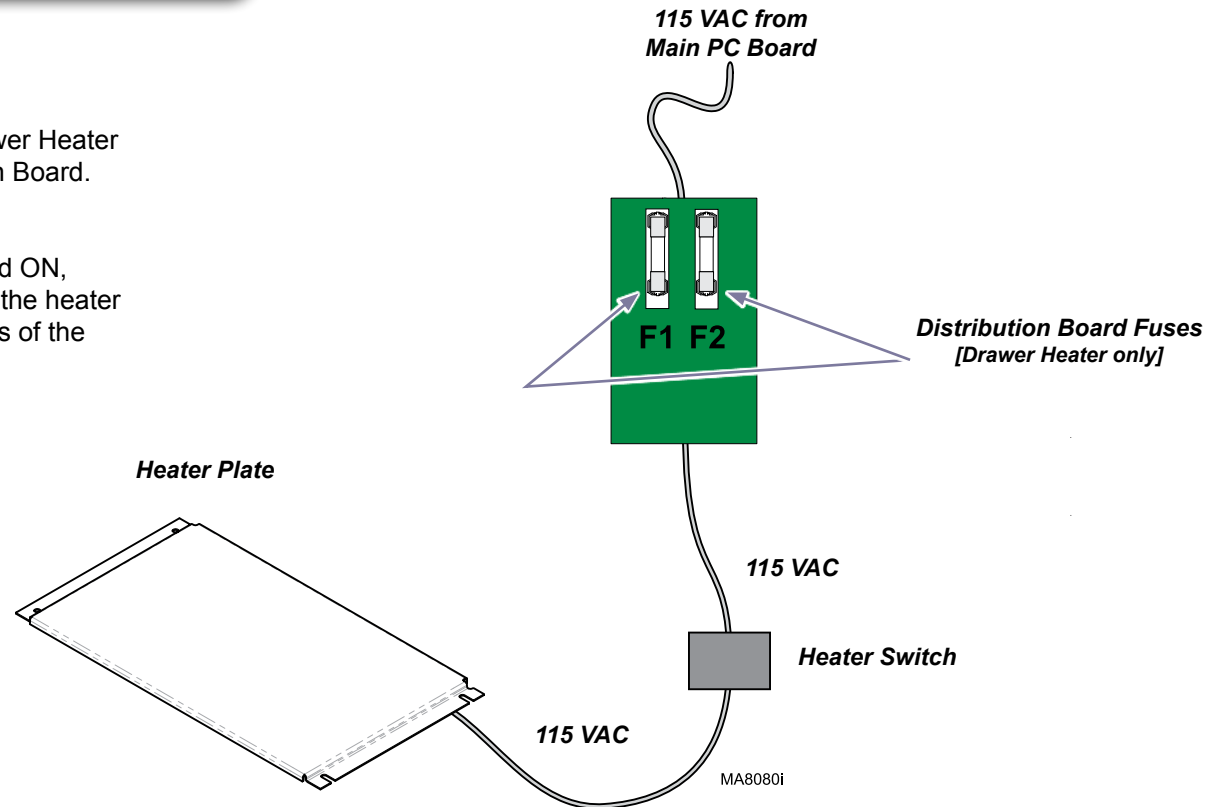

Models:	625 (-001 /-003 /-004 /-006
Serial Numbers:	<i>all</i>

Table Receptacle (optional)

This illustration shows only the components that affect the table receptacle. A detailed description of current flow during this function also appears below.

No Power At Table Receptacle.....A-6

Table Receptacle

115 VAC is supplied directly to the receptacle thru two inlet fuses, isolation transformer, and circuit breakers.
[Voltage bypasses the Main PC Board].

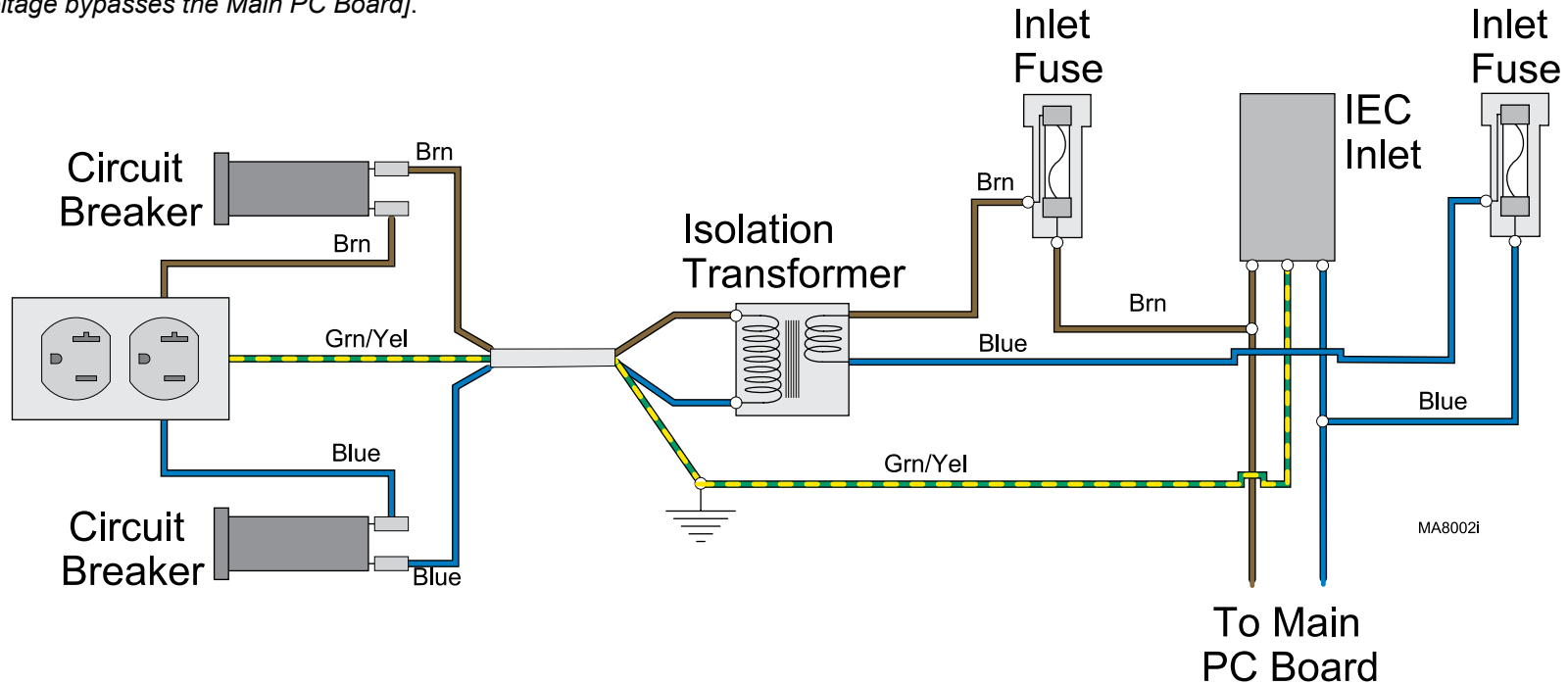

Models:	625 (-001 /-003)
Serial Numbers:	V2200 thru V1149713

Table Receptacles (optional)

This illustration shows only the components that affect the table receptacles. A detailed description of current flow during this function also appears below.

No Power At Table Receptacle.....A-6

Table Receptacles

115 VAC is supplied directly to the receptacles thru two inlet fuses, isolation transformer, and circuit breakers.
[Voltage bypasses the Main PC Board].

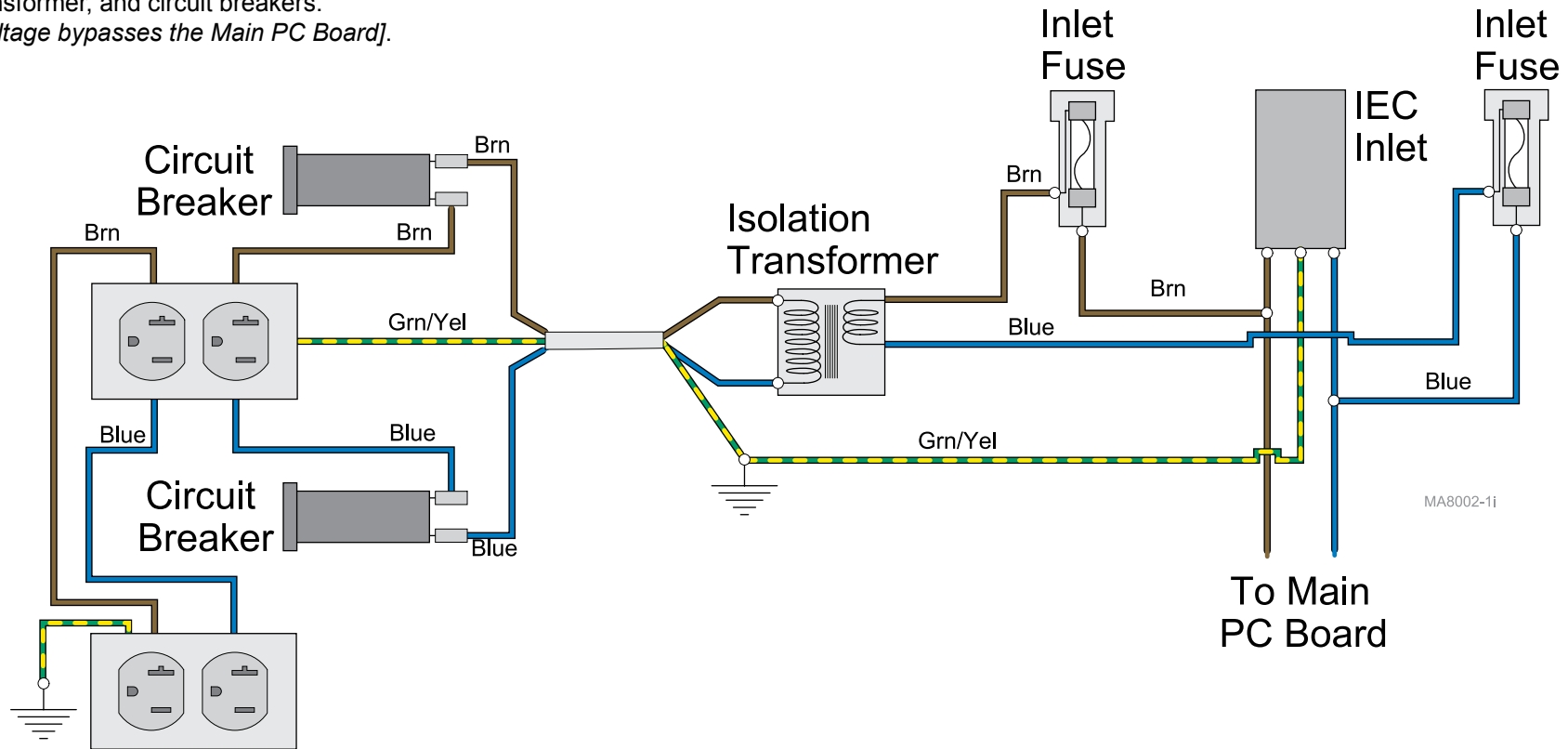

Models:	625 (-001 /-003)
Serial Numbers:	V1149714 thru Present

Table Receptacles

This illustration shows only the components that affect the table receptacles. A detailed description of current flow during this function also appears below.

No Power At Table Receptacle.....A-6

Table Receptacles

115 VAC is supplied directly to the receptacles thru two inlet fuses, isolation transformer, and circuit breakers.
[Voltage bypasses the Main PC Board].

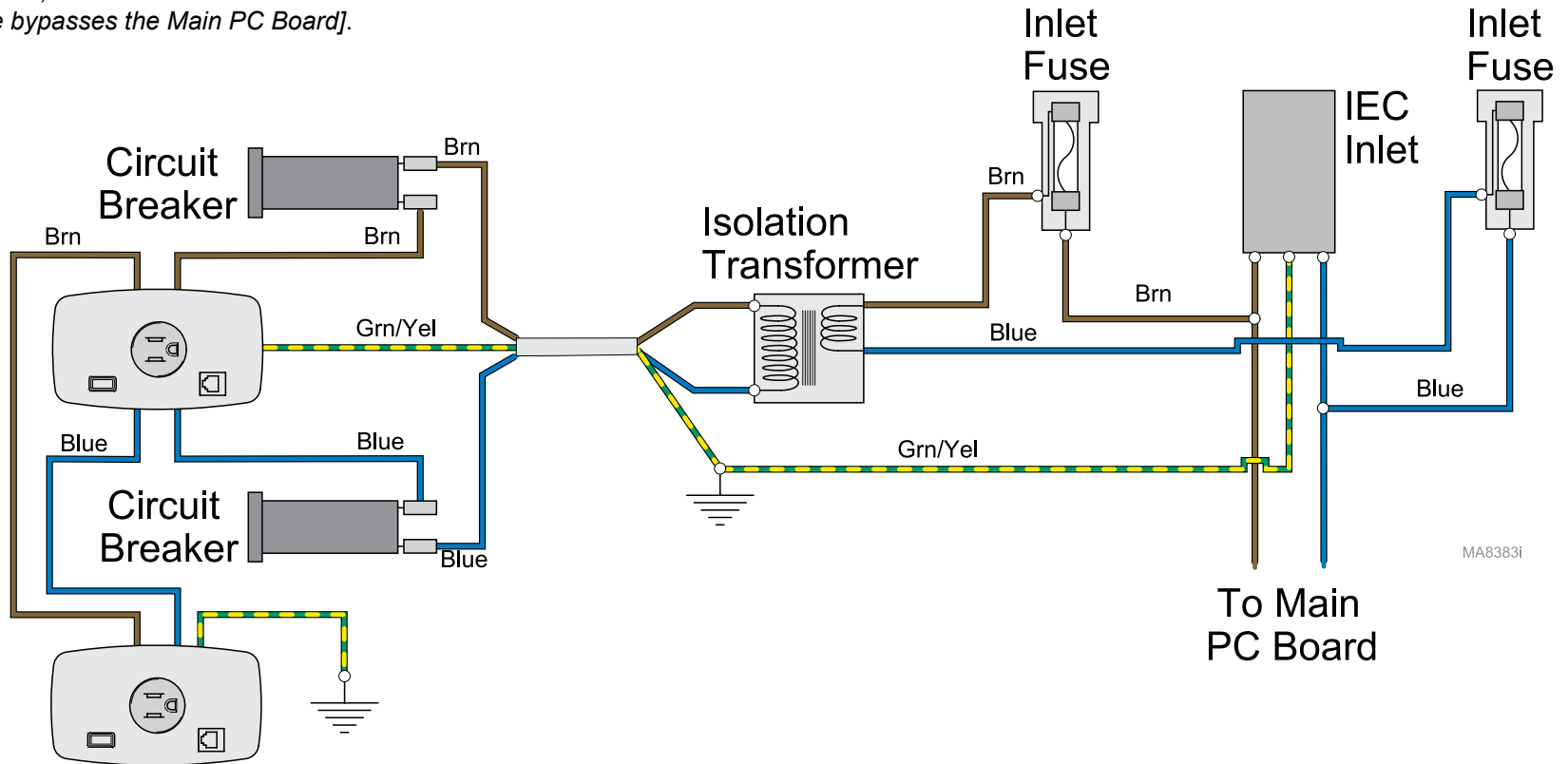

MA8383i

Models:	625 (-004)
Serial Numbers:	All

Scale Information Flow

This illustration shows only the components that affect the flow of information for weight. A detailed description of information flow during this function also appears below.



Hand Control

When activated, the hand control transmits the request through the antenna to the Base Station.

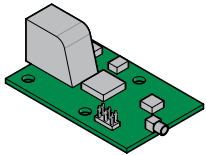

Base Station

When the Base Station receives the request, the “TX” light will flash momentarily. The Base Station then sends the request to the “LIN to Scale” board.

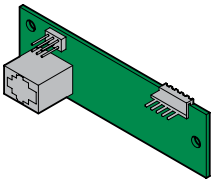

LIN to Scale Board

The LIN to Scale Board receives request from Base Station.

The LIN to Scale Board then asks for weight from the Scale Board.

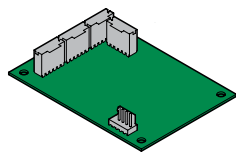

Scale Board

When the Scale Board receives request from LIN to Scale Board, the Red light will flash momentarily.

The Scale Board reads the weight from the load cells.

The Amber light will flash momentarily when the information is sent back to the LIN to Scale Board.

Note: Load cells are plugged into the Scale Board.

The LIN to Scale Board sends information back to Base Station.

The Base Station sends information back to Hand Control.

The Hand Control displays information.

Note: These steps happen even if the Hand Control has not requested a weight. The LIN to Scale Board is constantly monitoring weight.

Models:	625 (-004)
Serial Numbers:	<i>All</i>

Section B

Testing

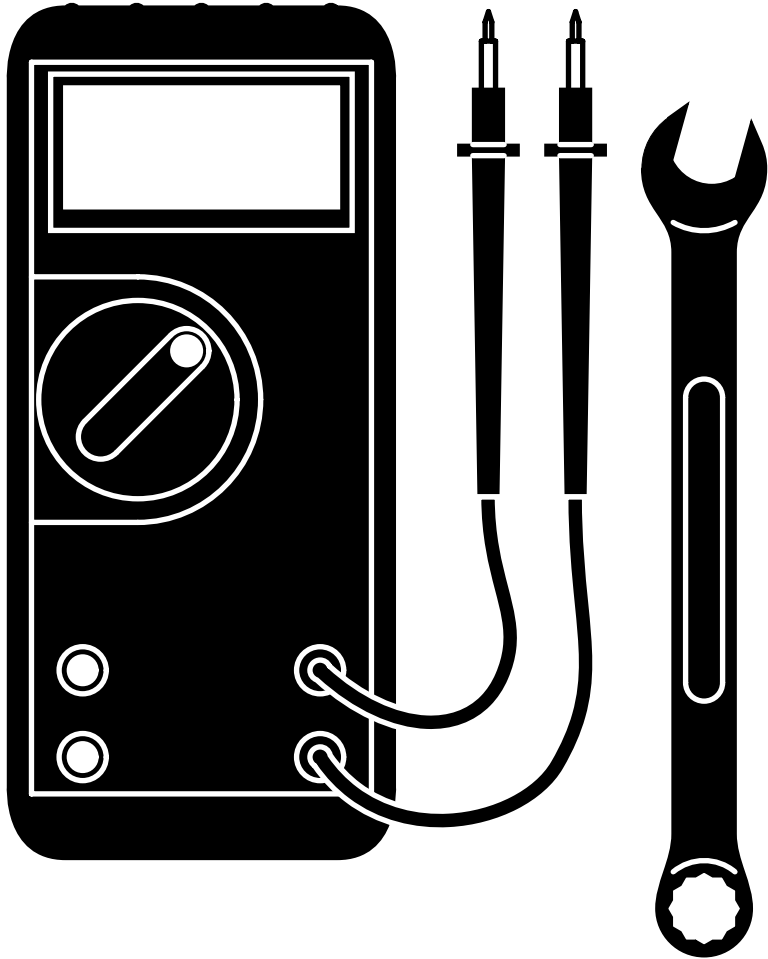

- [Foot / Hand Controls](#)B-2
- [Wireless Controls](#)B-4
- [Base Function Components](#)B-7
- [Base Limit Switch Test](#)B-8
- [Base PC Board Test](#)B-9
- [Base Actuator](#)
- [Motor Resistance Test](#).....B-10
- [Back Function Components](#)B-11
- [Back Limit Switch](#)B-12
- [Back PC Board Test](#)B-13
- [Back Actuator](#)
- [Motor Resistance Test](#).....B-14
- [Drawer Heater System](#)B-15
- [Table Calibration Procedure](#)B-20
- [Scale Calibration Procedure](#).....B-21

Foot / Hand Controls

Isolating a Malfunction

Foot / Hand Control Test	B-3
Access Procedures	C-1
Wiring Diagrams	D-1

To isolate a malfunction, try activating the inoperable function(s) from hand control and foot control.

- If function(s) are inoperable from the foot / hand control...**
- A) Plug the foot / hand control into the other connection port.
 - B) Secure Inlet harness connection(s) on main PC board at J12 & J13.
- If function(s) are operable:**
- C) Replace Inlet harness at malfunctioning connection port.
- If function(s) still inoperable:**
- D) Perform the [Foot / Hand Control Test](#).

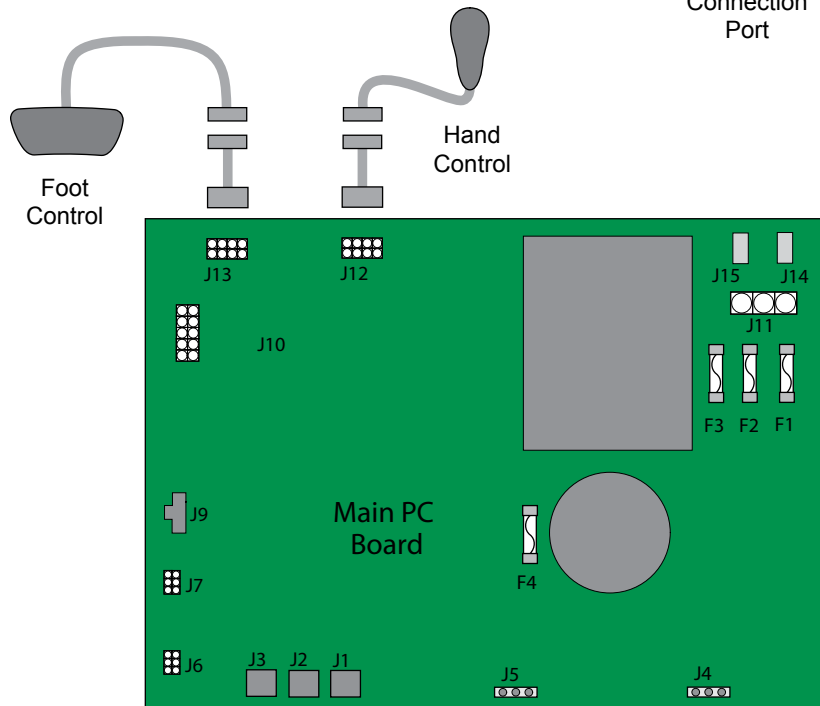
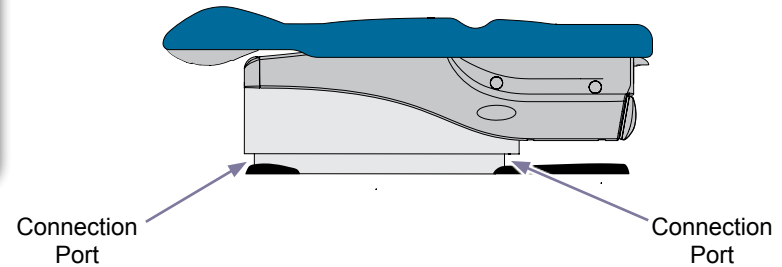

Note
Refer to "Wireless Controls" if applicable.

MA8118i

Models:	625
Serial Numbers:	<i>all</i>

Foot / Hand Controls - continued

Access Procedures.....	C-1
Wiring Diagrams.....	D-1

Foot / Hand Control Test

Note

Refer to "Wireless Controls" if applicable.

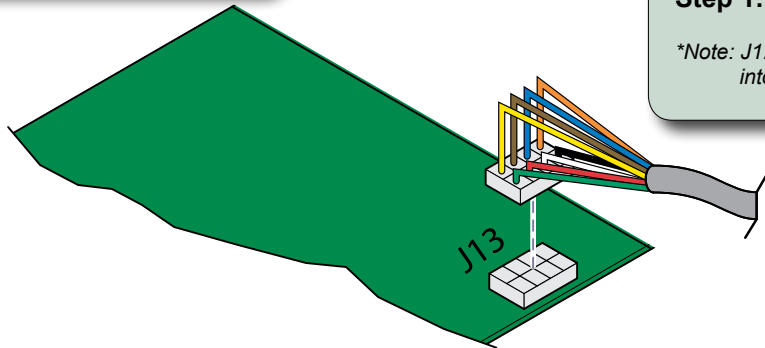

Step 1: Disconnect wire harness from J12 and J13 on main PC board.
 *Note: J12 and J13 are interchangeable. Either harness could be plugged into either J12 or J13.

Step 2: Set meter to Ω .

Step 3: Place one meter probe on black wire (common) of foot / hand control harness.

Place other meter probe on the wire that corresponds to the switch to be tested.

Switch.....Wire Color

- Base Up.....white
- Base Down.....red
- Back Up.....green
- Back Down.....orange
- Home.....blue
- Stop.....brown
- Quick Exam™.....yellow

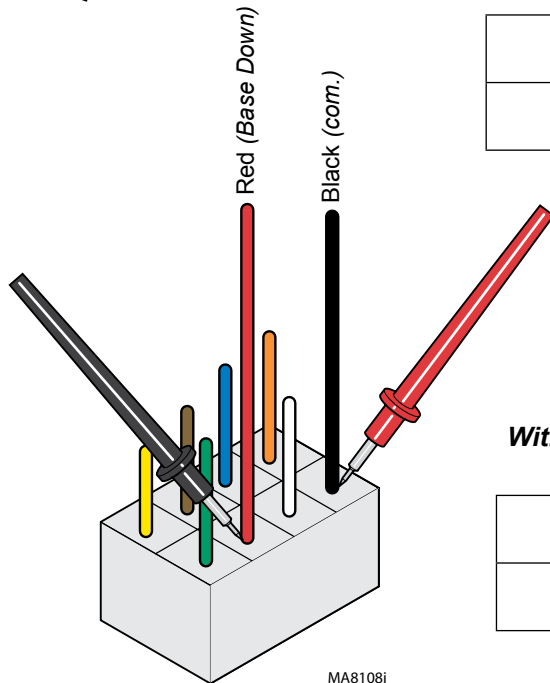

MA8108i

With switch "untripped"...

Meter Reading	Required Action
Any resistance reading	Replace control / switch membrane.
OL	Switch is good. Check fuses.

With switch "tripped"...

Meter Reading	Required Action
Less than or = to 5 ohms	Switch is good. Check fuses.
OL	Replace control / switch membrane.

Models:	625
Serial Numbers:	<i>all</i>

Isolating a Malfunction

Testing

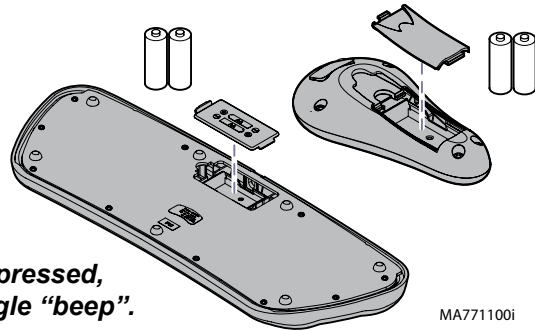

- **When any control button is pressed, that controller sounds a single “beep”.**
(All functions operate)

Cause:

1. Low battery
2. Faulty PC board in controller

Solution:

1. Replace batteries (size: AA)
2. Replace PC board in controller

- **When any control button is pressed, nothing happens.**
(No “beeps”, no movement, etc.)

Check:

1. Perform Association Procedure
2. LEDs on base station PC board

If LED status is normal (see illustration):

- Check LEDs on foot control PC board (see next page).

If no LEDs are illuminated, check the following:

- Modular harness (loose connections, damage, etc.)
- Power supply to chair
- Replace base station PC board if necessary.



Equipment Alert
Antenna connection is very delicate.
Do not kink wire or apply stress to connection.

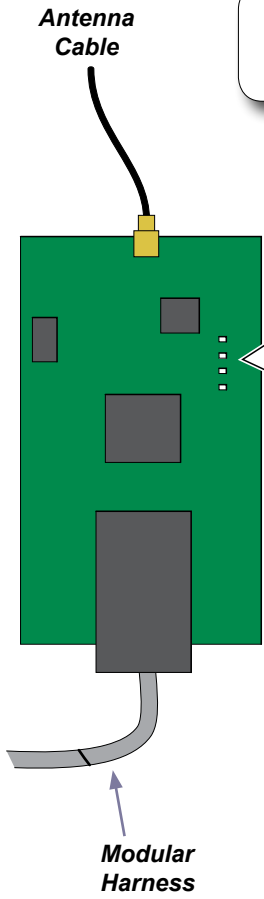

<u>LEDs</u>	<u>Normal Status</u>
<input type="checkbox"/> TX	(OFF - except during Association Procedure)
<input checked="" type="checkbox"/> RX	(ON - except during Association Procedure)
<input checked="" type="checkbox"/> COM	(ON)
<input checked="" type="checkbox"/> PWR	(ON)

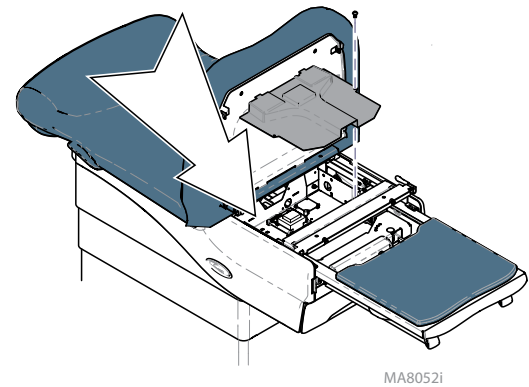

Models:	625	
Serial Numbers:	<i>all</i>	

Testing - continued

- **When any control button is pressed, nothing happens.** - continued
(No “beeps”, no movement, etc.)

(see previous page for Checks 1 & 2)

Check: 3. LEDs on hand / foot control PC board
(press any button on hand / foot control)

If LEDs function properly (see illustration):

- Check antenna connection. (see parts list for detail)
- Replace antenna if necessary.

If LEDs do not function properly:

- Replace batteries in controller (size: AA)
- Replace controller touch membrane
- Replace controller PC board if necessary.

LEDs

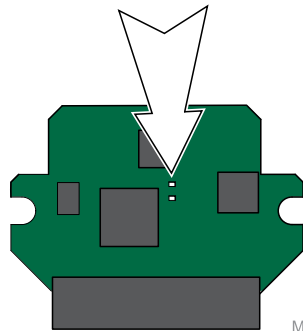
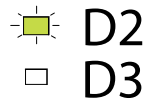

MA7936i

Hand / Foot Control PC Board
(refer to parts list for location)

Normal Status

(ON - only when a button on controller is pressed)

(OFF - except during Association Procedure)

LEDs

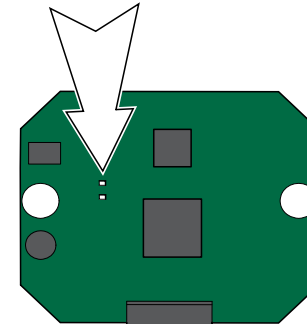
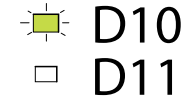

MA8444i

Hand Control / w Scale PC Board
(625-004 Only)
(refer to parts list for location)

Models:	625	
Serial Numbers:	<i>all</i>	

Wireless Controls - continued

Association Procedure

The wireless controllers will only function with the chair they have been “associated” with. This prevents unwanted movement in locations with more than one chair.

Each wireless controller’s association is preset at the factory. This procedure is only required in the event of a malfunction, if a new controller is purchased, or if you are attempting to use the controller with a chair other than the one it was originally associated with.

NOTE: The base station PC board only stores the last two associated controllers. To ensure proper operation, Midmark recommends reassociating both controllers (hand & foot), even if only one new controller is purchased.

Association Procedure:

- A) Disconnect power to the table for at least 3 seconds.
 - B*) Reconnect power, wait for the power up beep sequence from the table, then press & hold the **Stop & Home** buttons on the **wireless controller** until you hear three “beeps”.
- * Note: Step B must be performed within 10 seconds of the power up beep sequence from the table.
- C) Check for proper operation of wireless controller.
 - D) If associating a hand **and** foot control, repeat procedure using the other wireless controller.

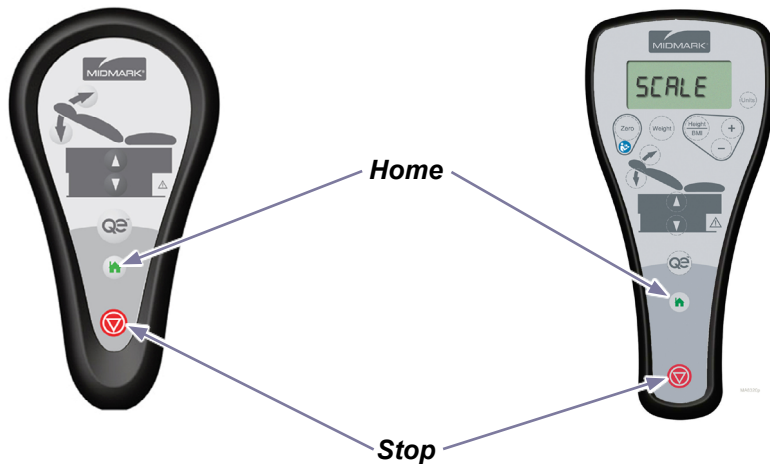

Models:	625	
Serial Numbers:	<i>all</i>	

Base Function Components

Isolating a Malfunction

This illustration shows the base limit switches, the serviceable components of the base actuator, and the fuses on the main PC board. Use the table below to isolate the malfunction.

[Wiring Diagrams](#)D-1
[Base Actuator / Motor Replacement](#) 003-2072-00

Problem	Required Action
Motor does not run.	Check main PC board fuses (F1, F2, F3, & F4) Perform Limit Switch Test .
Base function operates, but makes grinding / squeaking noises	Clean / lube actuator threads. Remove any debris from base slides. <i>Note: Do not lubricate base slides.</i> Replace actuator if necessary*.
Motor runs, but table does not move.	Inspect / replace motor coupler.

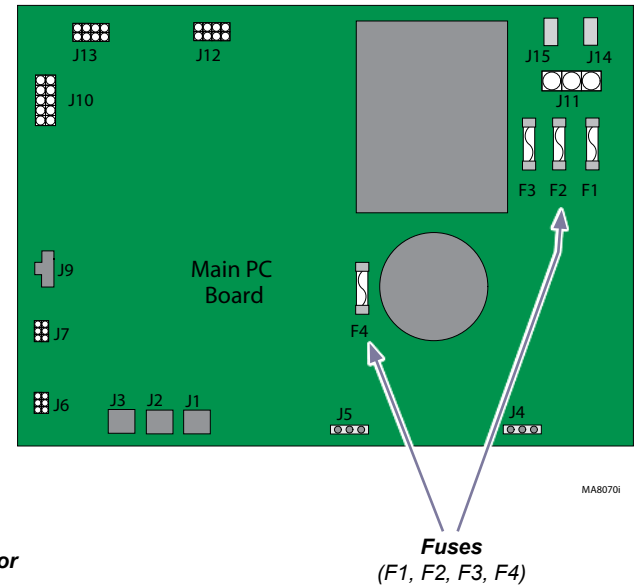
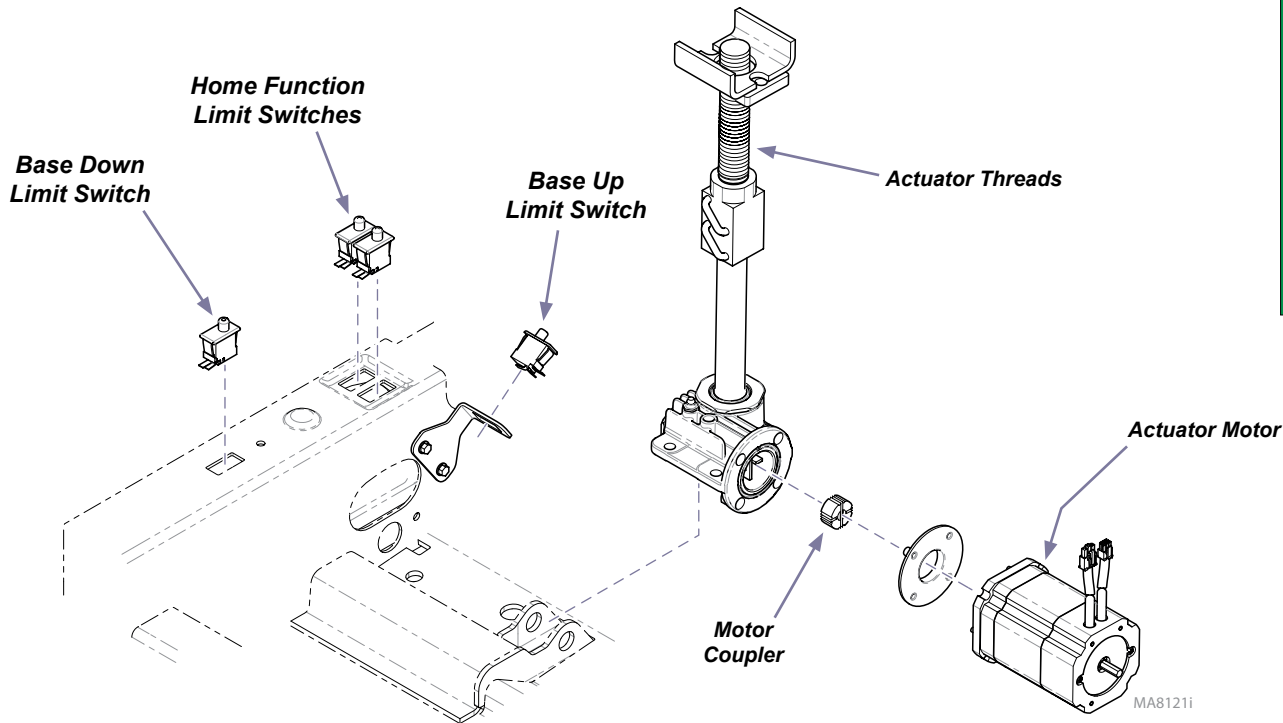

Models:	625
Serial Numbers:	<i>all</i>

* Replacement instructions are provided with the part. They are also available on midmark.com, or by clicking on the blue link.

Base Function Components - continued

Limit Switch Test

Step 1: Disconnect wires from switch.

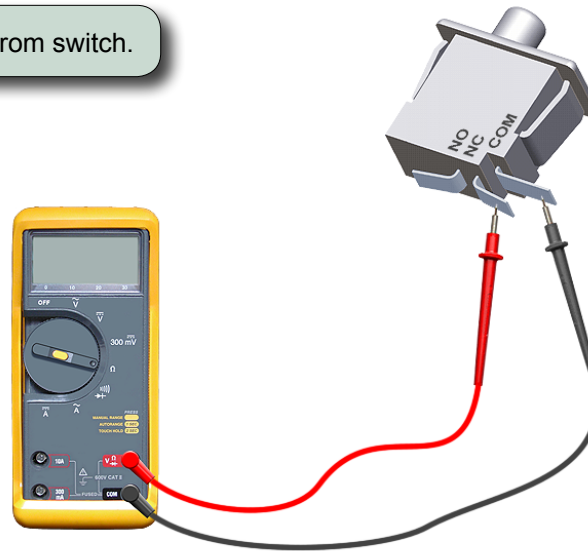

Step 2: Place meter probes on **COM** and **NC** terminals.

Note: Check switch “tripped” and “untripped”.

With switch “untripped”...

Meter Reading	Required Action
OL	Replace limit switch
less than 5 ohms	Limit switch - OK Perform PC Board Test

With switch “tripped”...

Meter Reading	Required Action
OL	Limit switch - OK Perform PC Board Test
less than 5 ohms	Replace limit switch

Models:	625	
Serial Numbers:	all	

Base Function Components - continued

[Calibration Procedure.....B-20](#)
[PC Board Replacement..... 003-2073-00](#)

PC Board Test

Equipment Alert
 The back limit switches will not stop movement during this test.
 Do **not** run past max. / min. positions.

Step 1: Move **Back** section so that it is approx. halfway between its maximum & minimum positions.

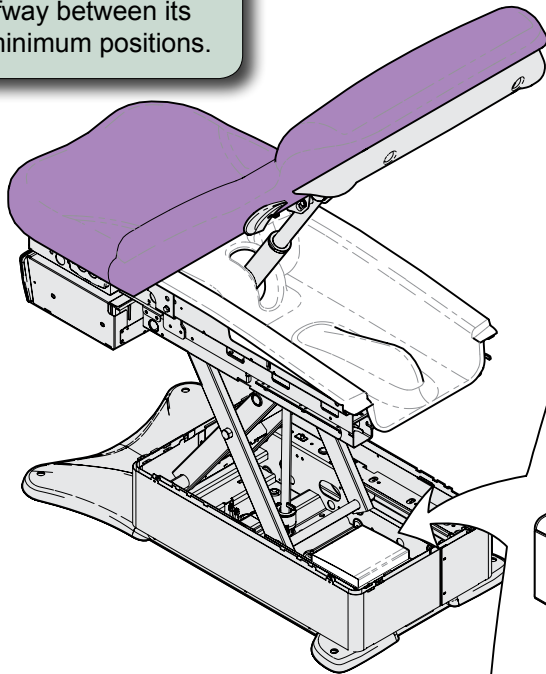

Did BASE move Up and Down in Step 4?	Required Action
YES	Replace main PC board
NO	Refer to: Base Actuator Motor Resistance Test

Step 4: Using the hand / foot control:
 A) Press & hold **BACK UP** briefly.
 B) Press & hold **BACK DOWN** briefly.

Equipment Alert
 Failure to move **both** connections may result in damage to PC Board.

Step 3: Move base actuator connection to J4 and base sensor connection to J7.

Step 2: Tag, then disconnect back & base actuator wire connections at J4 & J5. Tag then disconnect back & base sensor wire connections at J6 & J7.

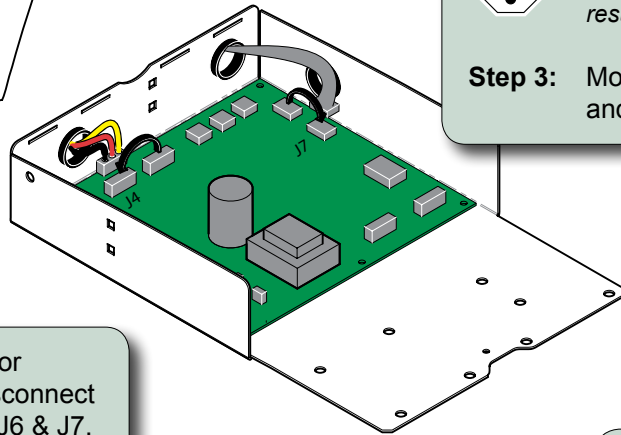

MA8077i

Step 5: Calibrate PC Board.

Models:	625
Serial Numbers:	all

* Replacement instructions are provided with the part. They are also available on midmark.com, or by clicking on the blue link.

Base Actuator Motor Resistance Test

Isolating a Malfunction

[Calibration Procedure](#).....B-20

[Base Actuator /
Motor Replacement](#)..... 003-2072-00



Equipment Alert

Anytime actuator wires are disconnected, the PC Board must be calibrated.

Step 1:

- A) Disconnect power to the table.
- B) Disconnect back actuator from J6 on PC Board.
- C) Set multimeter to Ohms to check resistance.

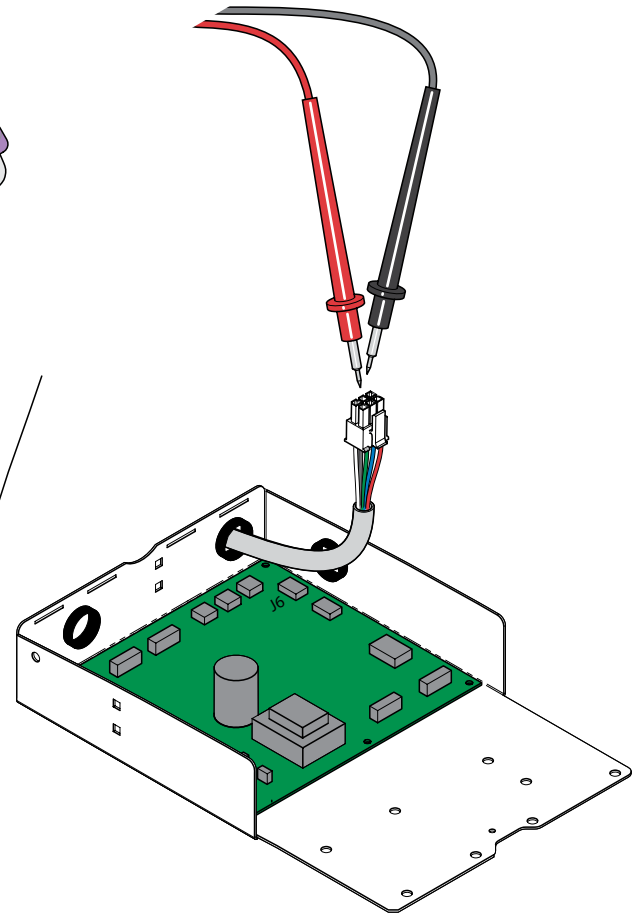
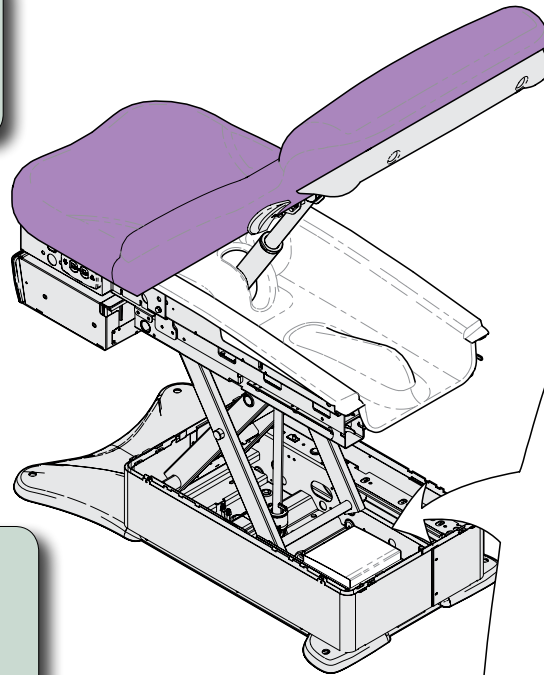

Step 2:

- A) Place the Red meter probe on the Black wire, and the Black meter probe on the Blue wire.
- B) Place the Red meter probe on the Black wire, and the Black meter probe on the Green wire.
- C) Place the Red meter probe on the Black wire, and the Black meter probe on the White wire.

If any of the readings are less than two Mega Ohms after three seconds, the motor is defective.

Models:	625
Serial Numbers:	<i>all</i>

Back Function Components

Isolating a Malfunction

This illustration shows the back limit switches, the serviceable components of the back actuator, and the fuses on the main PC board. Use the table below to isolate the malfunction.

[Wiring Diagrams.....D-1](#)

[Back Actuator / Motor Replacement..... 003-2071-00](#)

Problem	Required Action
Motor does not run.	Check main PC board fuses (F1, F2, F3, & F4) Perform Limit Switch Test
Back function operates, but makes grinding / squeaking noises	Clean / lube actuator threads. Replace actuator if necessary*.
Motor runs, but table does not move.	Inspect / replace motor coupler.

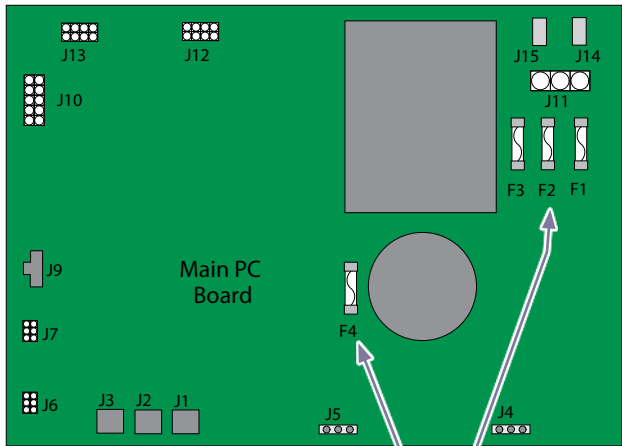

Fuses
(F1, F2, F3, F4)

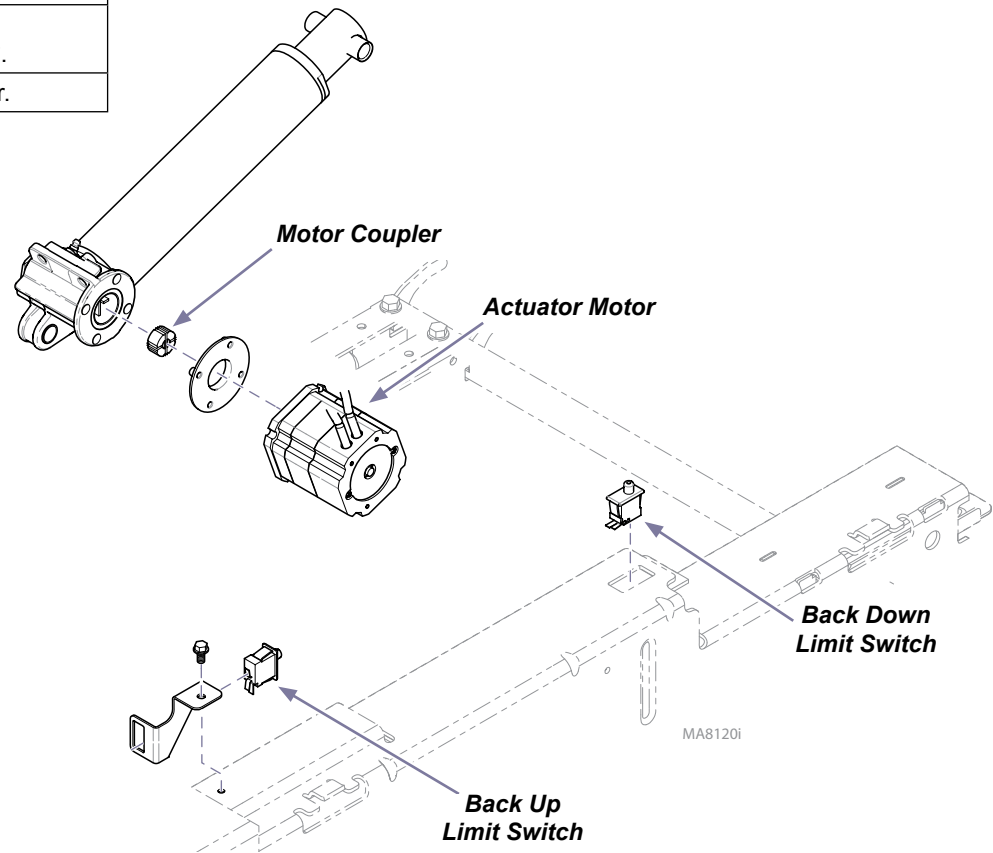

Models:	625
Serial Numbers:	<i>all</i>

* Replacement instructions are provided with the part. They are also available on midmark.com, or by clicking on the blue link.

Back Function Components - continued

Limit Switch Test

Step 1: Disconnect wires from switch.

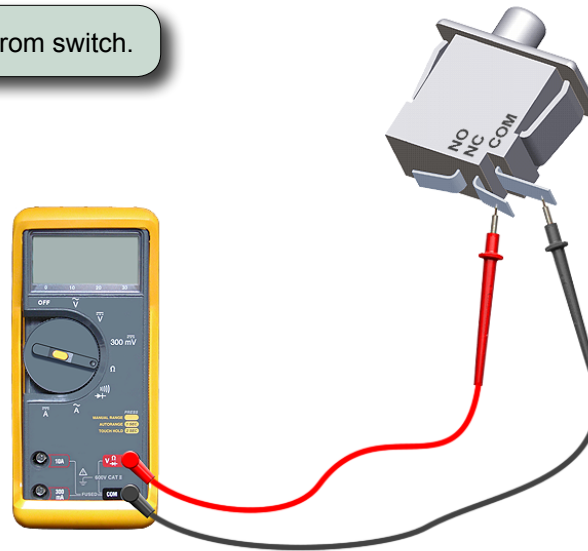

Step 2: Place meter probes on **COM** and **NC** terminals.

Note: Check switch “tripped” and “untripped”.

With switch “untripped”...

Meter Reading	Required Action
OL	Replace limit switch
less than 5 ohms	Limit switch - OK Perform PC Board Test .

With switch “tripped”...

Meter Reading	Required Action
OL	Limit switch - OK Perform PC Board Test .
less than 5 ohms	Replace limit switch

Models:	625	
Serial Numbers:	all	

Back Function Components - continued

[Calibration Procedure.....B-20](#)
[PC Board Replacement..... 003-2073-00](#)

PC Board Test

Equipment Alert
 The base limit switches will not stop movement during this test.
 Do **not** run past max. / min. positions.

Step 1: Move Base section so that it is approx. halfway between its maximum & minimum positions.

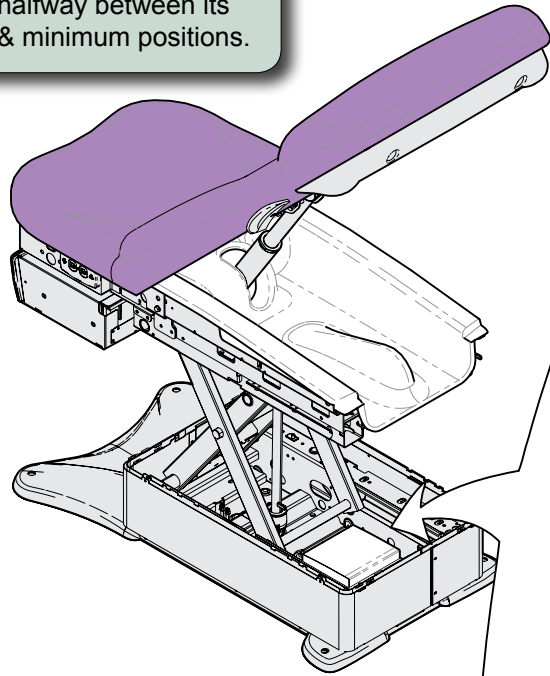

Did BACK move Up <u>and</u> Down in Step 4?	Required Action
YES	Replace main PC board*
NO	Refer to: Back Actuator Motor Resistance Test

Step 4: Using the hand / foot control:
 A) Press & hold **BASE UP** briefly.
 B) Press & hold **BASE DOWN** briefly.

Equipment Alert
 Failure to move **both** connections may result in damage to PC Board.

Step 3: Move back actuator connection to J5 and back sensor connection to J6.

Step 2: Tag, then disconnect back & base actuator wire connections at J4 & J5. Tag then disconnect back & base sensor wire connections at J6 & J7.

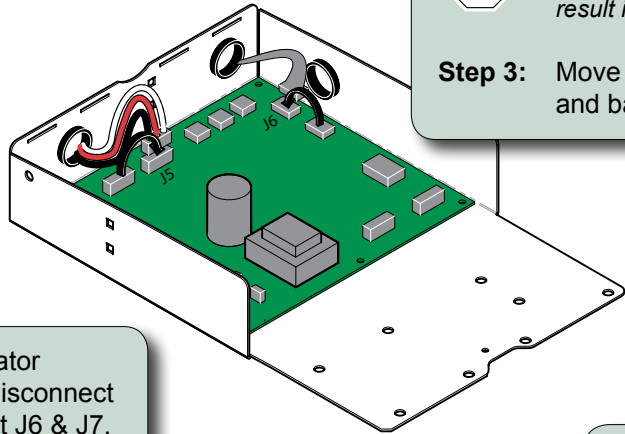

MA8073i

Step 5: Calibrate PC Board.

Models:	625
Serial Numbers:	<i>all</i>

* Replacement instructions are provided with the part. They are also available on midmark.com, or by clicking on the blue link.

Back Actuator Motor Resistance Test

Isolating a Malfunction

[Calibration Procedure.....B-20](#)
[Back Actuator /
Motor Replacement..... 003-2071-00](#)

Equipment Alert
Anytime actuator wires are disconnected, the PC Board must be calibrated.

Step 1:
A) Disconnect power to the table.
B) Disconnect back actuator from J7 on PC Board.
C) Set multimeter to Ohms to check resistance.

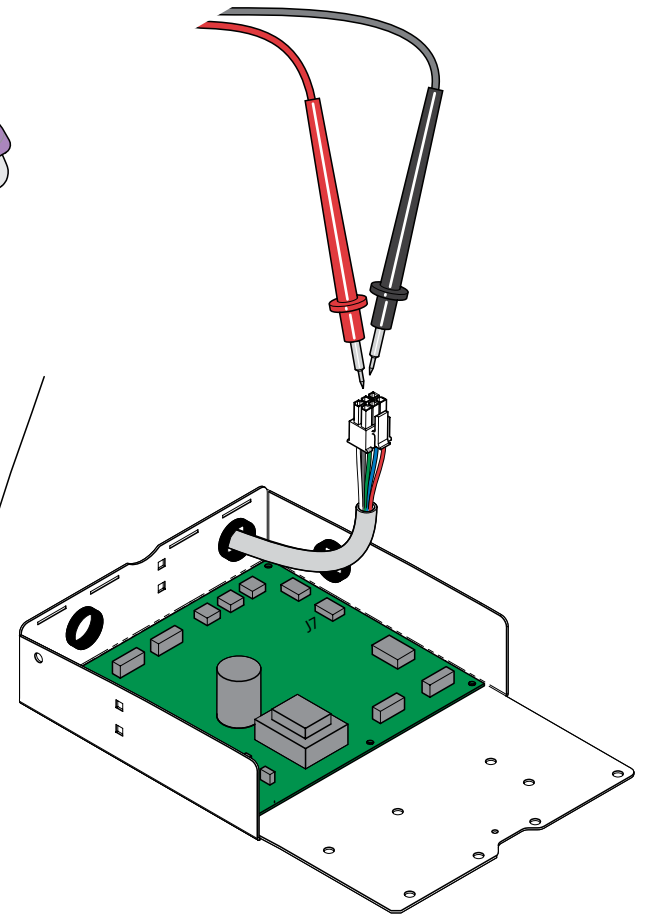
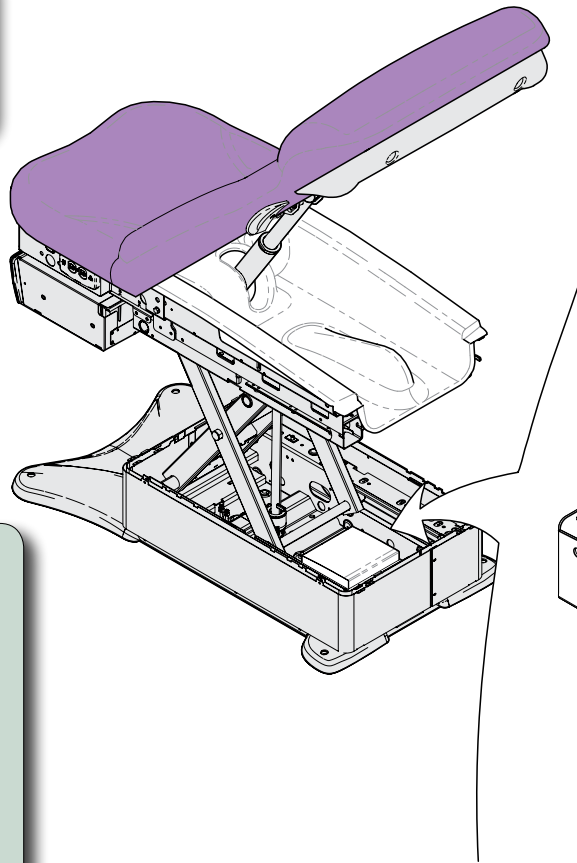

MA9348i

Step 2:
A) Place the Red meter probe on the Black wire, and the Black meter probe on the Blue wire.
B) Place the Red meter probe on the Black wire, and the Black meter probe on the Green wire.
C) Place the Red meter probe on the Black wire, and the Black meter probe on the White wire.

If any of the readings are less than two Mega Ohms after three seconds, the motor is defective.

Models:	625
Serial Numbers:	<i>all</i>

Drawer Heater System

Distribution Board Test

Heater Switch Test	B-16
Heater Switch Replacement	B-17
Heater Plate Test	B-18
Heater Plate Replacement	B-19
Chair Arm Brace Removal	C-8
Wiring Diagrams	D-1

Caution
Unplug power cord before removing stirrup guide.

Step 1: Remove stirrup guide.
Note: If necessary, remove chair arm brace (see Access Procedures).

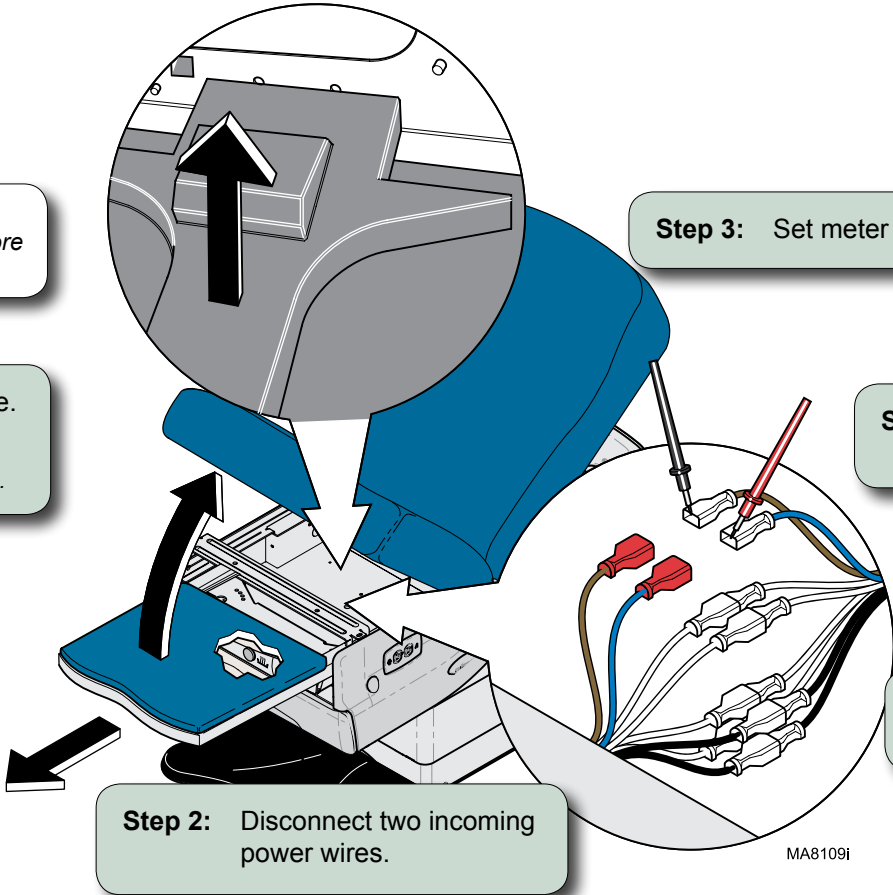

Step 3: Set meter to 200 VAC.

Step 4: Place meter probes on incoming power wires.

Step 5: Plug in power cord, then depress switch ON.

Step 2: Disconnect two incoming power wires.

MA8109i

Meter Reading	Required Action
approx. 115 VAC	Perform Heater Switch Test .
0 VAC	Check connections & distribution board fuses.

Models:	625 (-001 /-003 /-004 /-006)
Serial Numbers:	all

Drawer Heater System - continued

Heater Switch Test

[Heater Switch Replacement](#)..... B-17
[Heater Plate Test](#)..... B-18
[Chair Arm Brace Removal](#)..... C-8



Caution
Unplug power cord before removing stirrup guide.

Step 1: Remove stirrup guide.

Note: If necessary, remove chair arm brace (see Access Procedures).

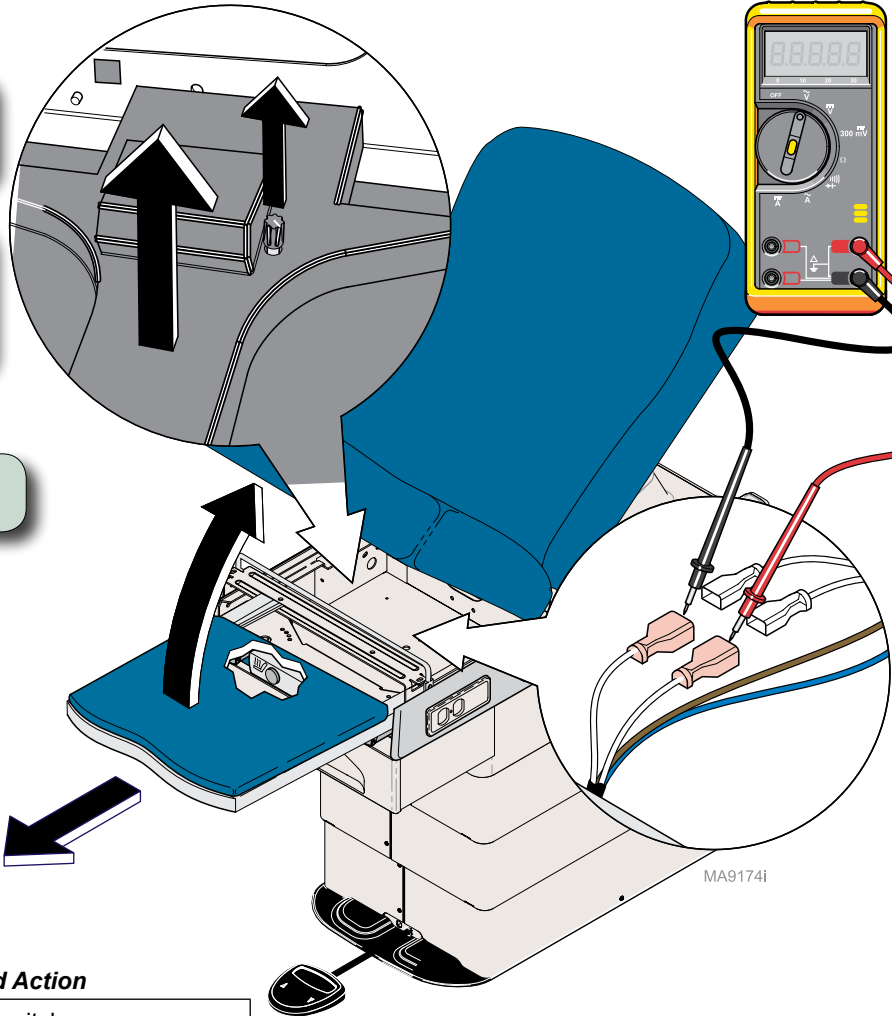

Step 3: Set meter to 200 VAC.

Step 4: Place meter probes on two white leads from switch.

Step 2: Disconnect two white leads from drawer heater switch to the drawer heater.

Step 5: Plug in power cord, then depress switch ON.

Step 7: Replace stirrup guide.

Caution
Unplug power cord before re-connecting electrical leads.

Step 6: Re-connect electrical leads.

Meter Reading	Required Action
0 VAC	Replace switch.
approx. 115 VAC	Switch - OK Perform Heater Plate test

Models:	625 (-001 /-003 /-004 /-006)
Serial Numbers:	all

Drawer Heater System - continued

[Access Procedures](#)
[Chair Arm Brace Removal](#).....C-8

Heater Switch Replacement

(This procedure also applies to the upholstery heater switch)



Caution

Unplug power cord before removing stirrup guide.

Step 1: Remove stirrup guide.

Note: If necessary, remove chair arm brace (see Access Procedures).

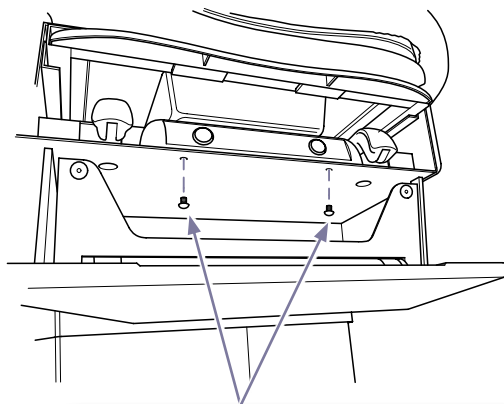

Step 3: Remove switch housing.

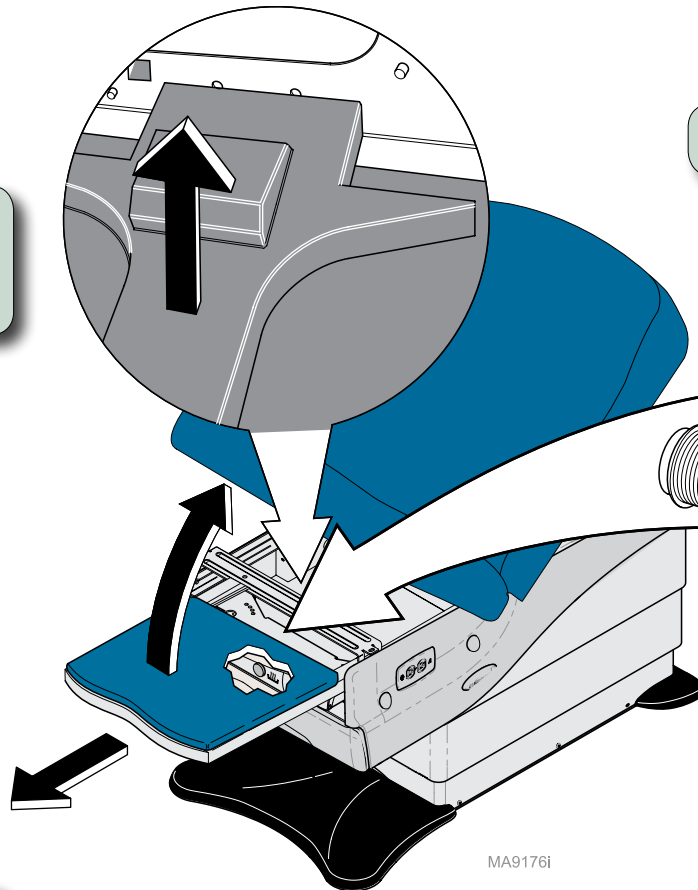

Step 2: Disconnect switch harness.

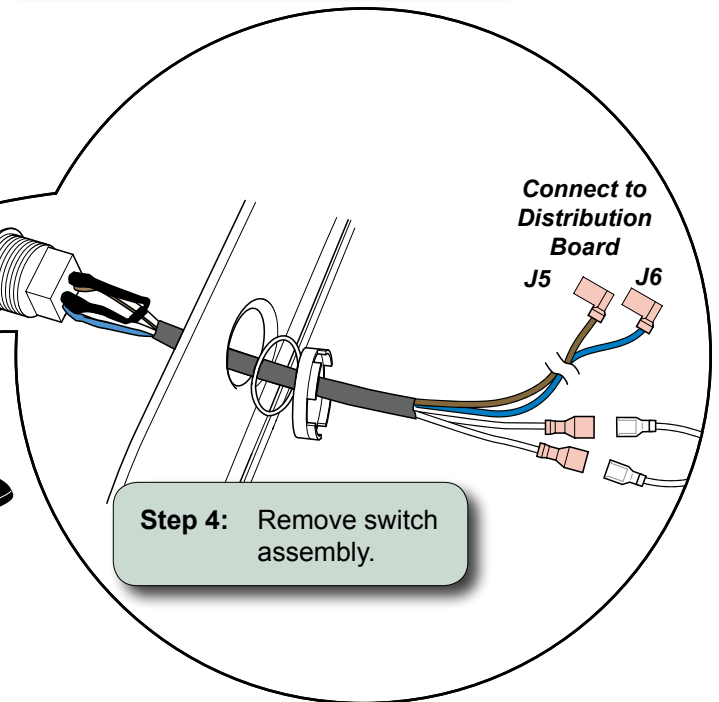

Step 4: Remove switch assembly.

- ### Step 5:
- A) Install switch assembly.
 - B) Install switch housing.
 - C) Re-connect switch harness.
 - D) Replace stirrup guide.

Models:	625 (-001 /-003 /-004 /-006)
Serial Numbers:	all

Drawer Heater System - continued

[Access Procedures](#)
[Chair Arm Brace Removal.....C-8](#)

Heater Plate Test



Caution
 Unplug power cord before removing stirrup guide.

Step 1: Remove stirrup guide.
 Note: If necessary, remove chair arm brace (see Access Procedures).

Step 6: Replace stirrup guide.

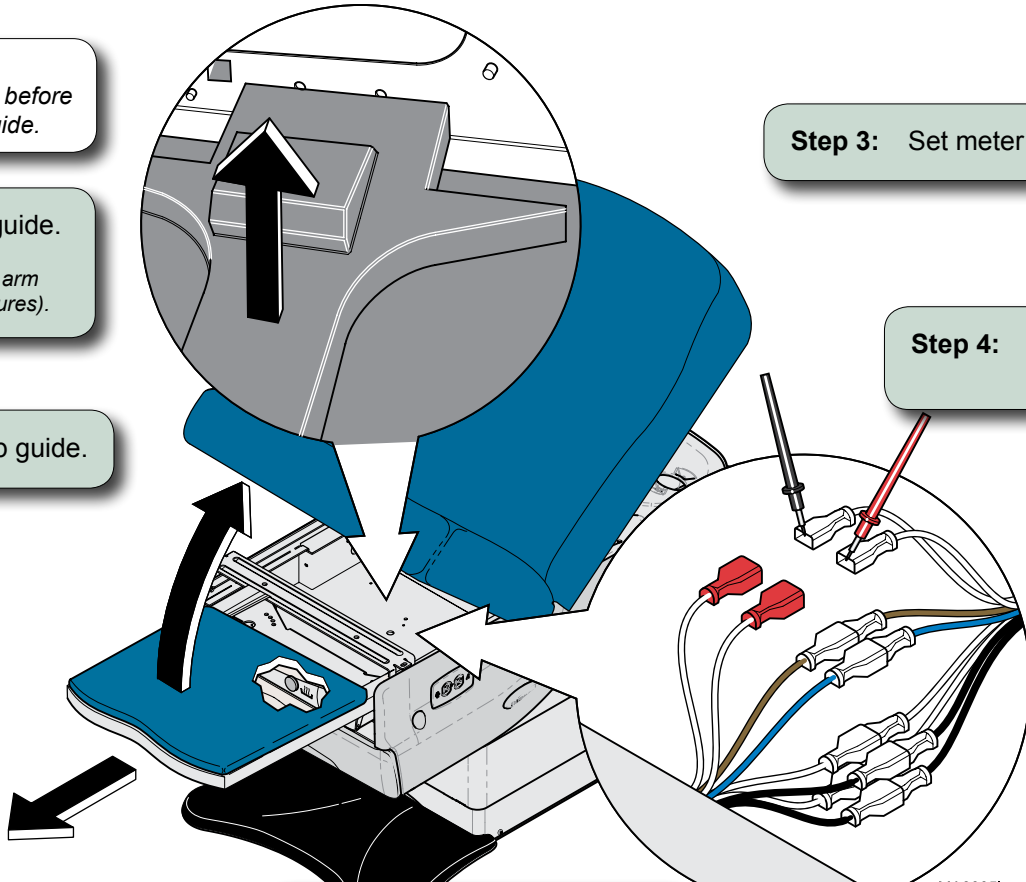

Step 3: Set meter to 2K Ω .

Step 4: Place meter probes on terminals of heater plate wires.

Step 2: Disconnect two white leads from drawer heater switch to the drawer heater.

Step 5: Re-connect electrical leads.

MA8005i

Meter Reading	Required Action
approx. 360 ohms	Heater plate - OK.
0 ohms	Replace Heater Plate.

Models:	625 (-001 /-003 /-004 /-006)
Serial Numbers:	all

Drawer Heater System - continued

[Access Procedures](#)
[Chair Arm Brace Removal.....C-8](#)

Heater Plate Replacement

Caution
Unplug power cord before removing stirrup guide.

Step 1: Remove stirrup guide.
Note: If necessary, remove chair arm brace (see Access Procedures).

Step 8: Replace stirrup guide.

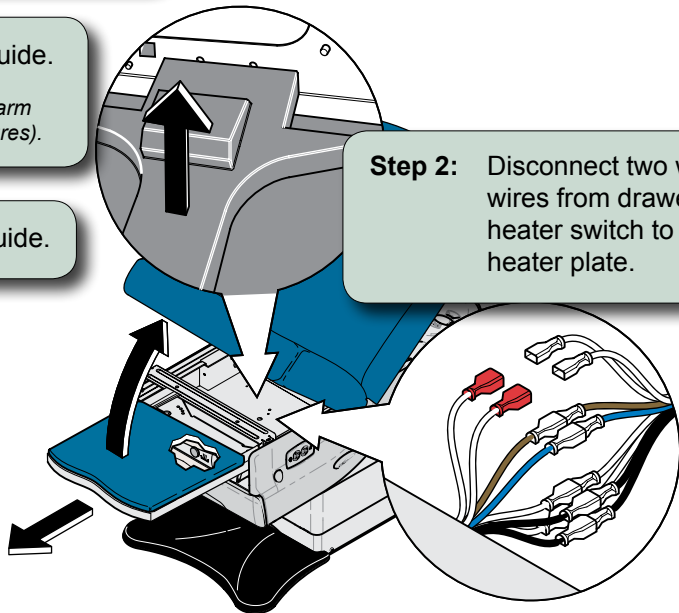

Step 2: Disconnect two white wires from drawer heater switch to the heater plate.

Step 3: Push LH slide lever UP and RH lever DOWN. Remove drawer.
Note: Slide levers are clear.

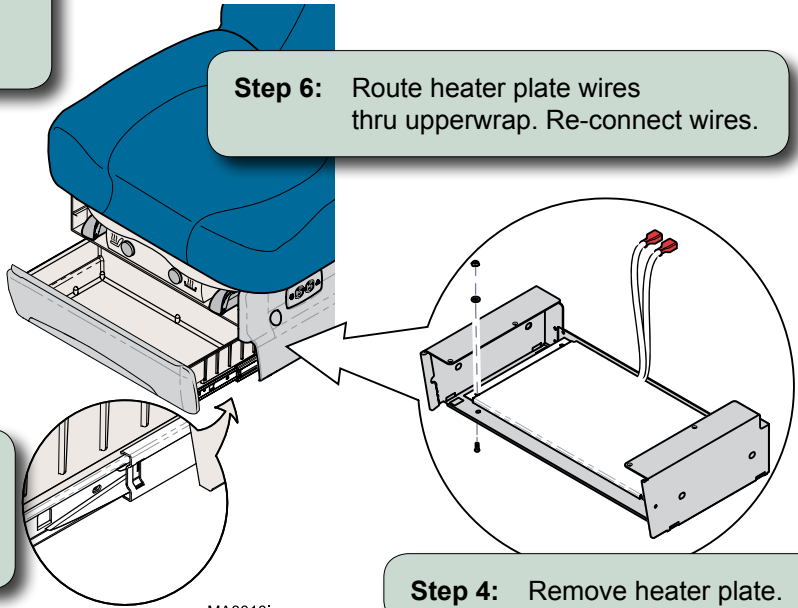

Step 6: Route heater plate wires thru upperwrap. Re-connect wires.

Step 4: Remove heater plate.

Step 5: Install heater plate.

Step 7: Install drawer.

Models:	625 (-001 /-003 /-004 /-006)
Serial Numbers:	all

Calibration Procedure

Note

When S2 switch is pressed you will hear a steady pattern of "beeps". When calibration is completed you will hear three short beeps.

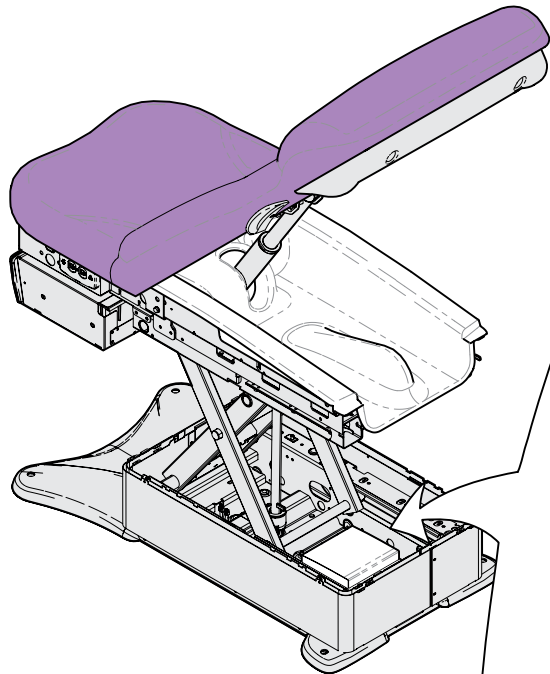

To calibrate...

- A) Unplug and re-plug power cord.
- B) Wait for the power up beep sequence from table, then within two seconds, press S2 switch.
- C) Run Base all the way down.
- D) Run Base all the way up.
- E) Run Back all the way down.
- F) Run Back all the way up.

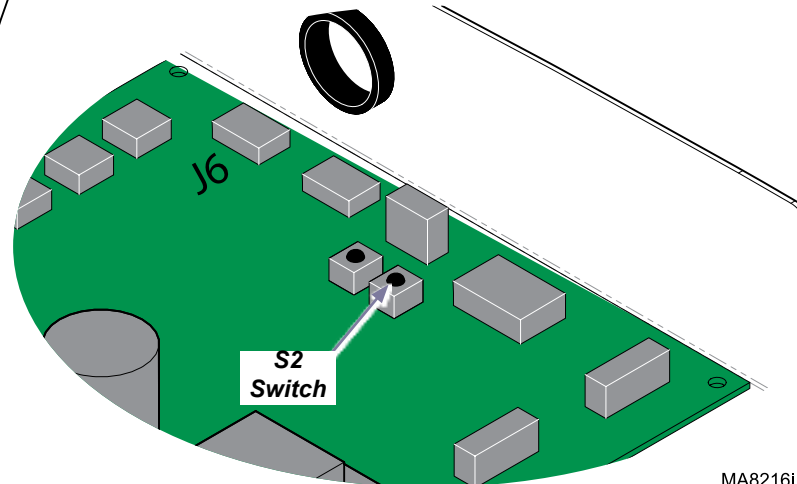

Scale Calibration Procedure (625-004 only)

Step 1:

- Remove any load from the patient surface.
- Press and hold the Weight and Plus buttons until "Pause" is displayed for at least one second, then release buttons.



Note

If abort message is displayed, unplug table for 60 seconds.
Remove and reinstall hand control batteries, then repeat step 1.

Step 2:

- When "CLrAL" is displayed, firmly press and release the plus button.
- After count down, "Ad50" will be displayed.

Note: If something other than "Ad50" is displayed, press the weight button until "Ad50" is displayed. (Early units may display "Add 50").



Step 3:

- Place fifty pound calibrated weight on patient surface.
 - Firmly press and release the plus button.
- Note: After count down "donE" will be displayed.



Step 4:

- Wait until display clears, then firmly press and release the weight button.
- Note: "50 lbs" should be displayed.
- Remove calibrated weight.



Section C

Access Procedures

Cladding Removal / Installation	C-2
Table Shrouds	
Removal / Installation	C-3
Raising / Lowering	
Table Manually	C-6
Upholstery	
Removal / Installation	C-7
Chair Arms / Brace	
Removal / Installation	C-8
Top Cover	
Removal / Installation	C-9

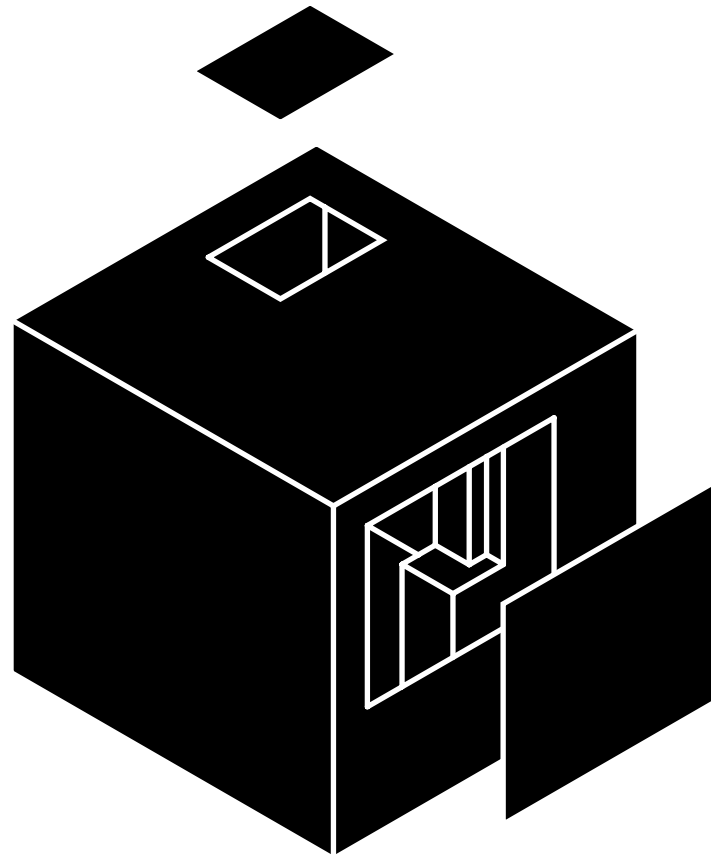

Cladding

Removal / Installation

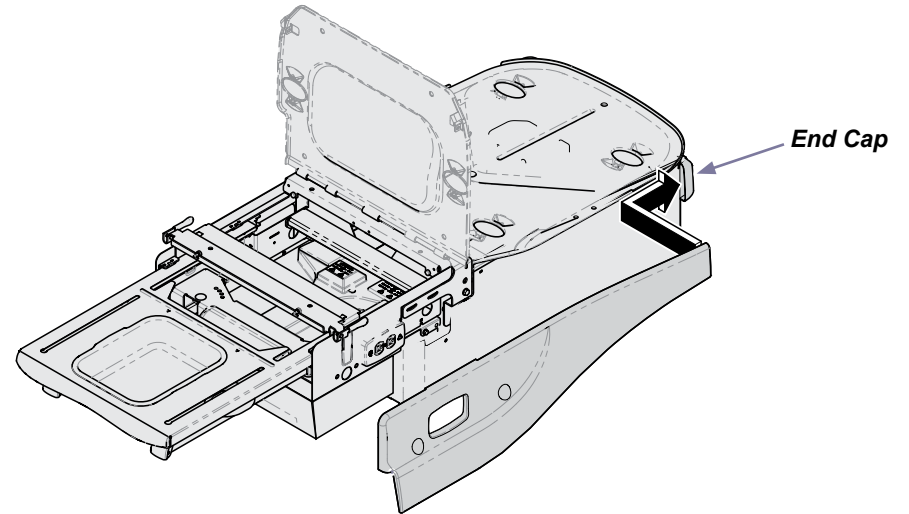
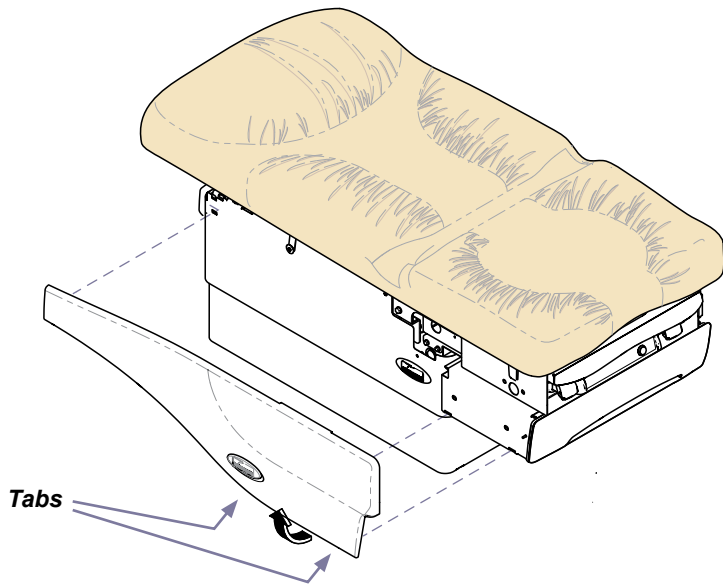

To remove cladding...

- Press two tabs.
- Pull bottom of cladding away from table.
- Lift cladding up to remove.

To install cladding...

- Insert tabs at head-end of cladding into side cladding holes.
- Slide cladding over upperwrap.
- Pull bottom of cladding out, then push down on the top to engage the long tab onto top edge of upperwrap.
- Push bottom of cladding in, until two bottom tabs snap into place.

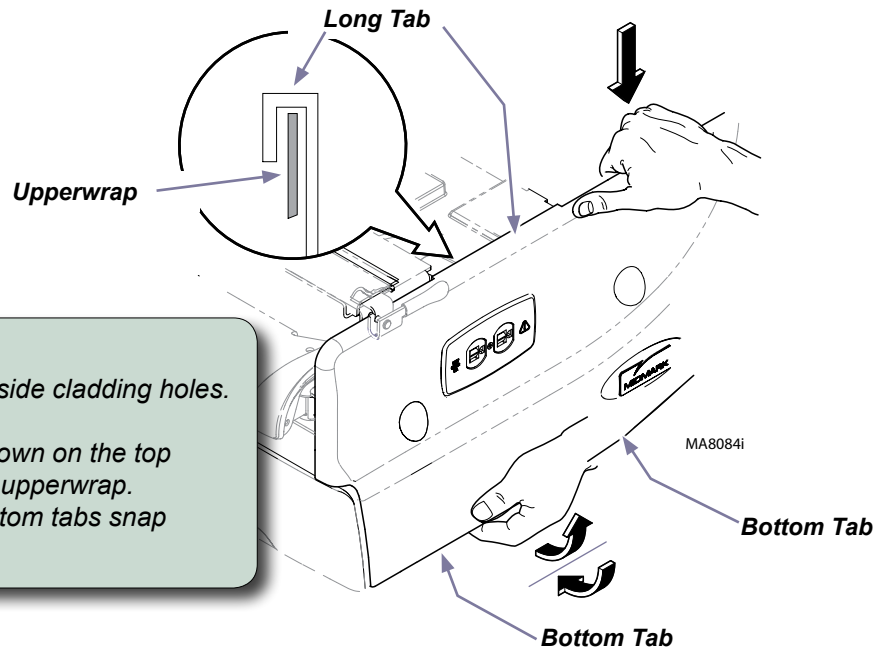

Models:	625
Serial Numbers:	<i>all</i>

Table Shrouds

Removal / Installation

Note
Remove all accessories (ex. chair arms) before performing this procedure.

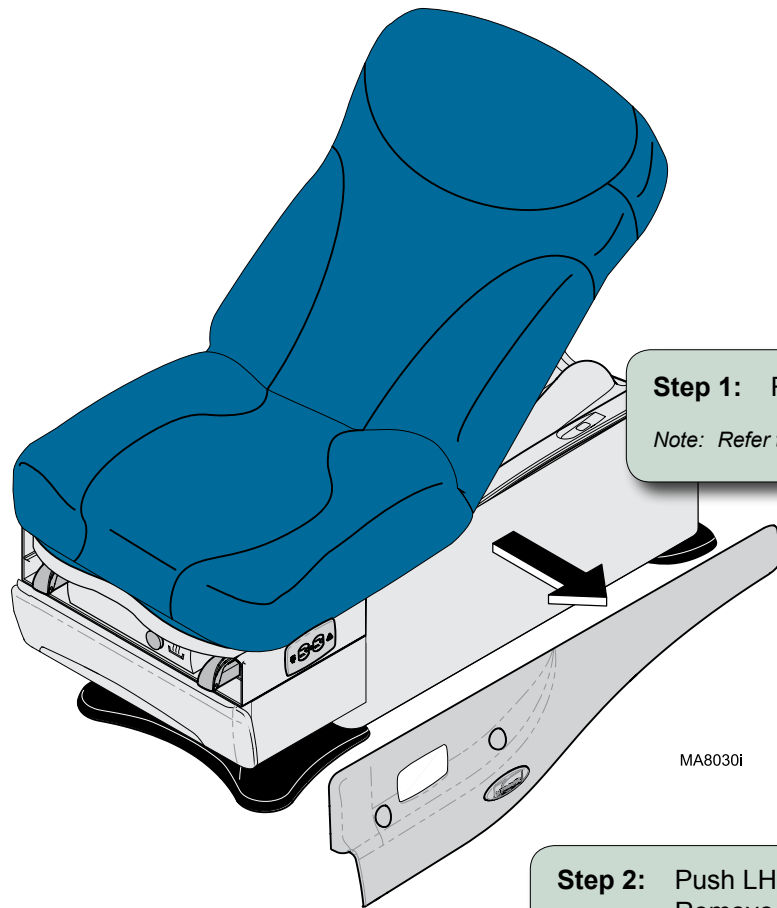

Step 1: Remove cladding.
Note: Refer to Cladding Removal / Installation.

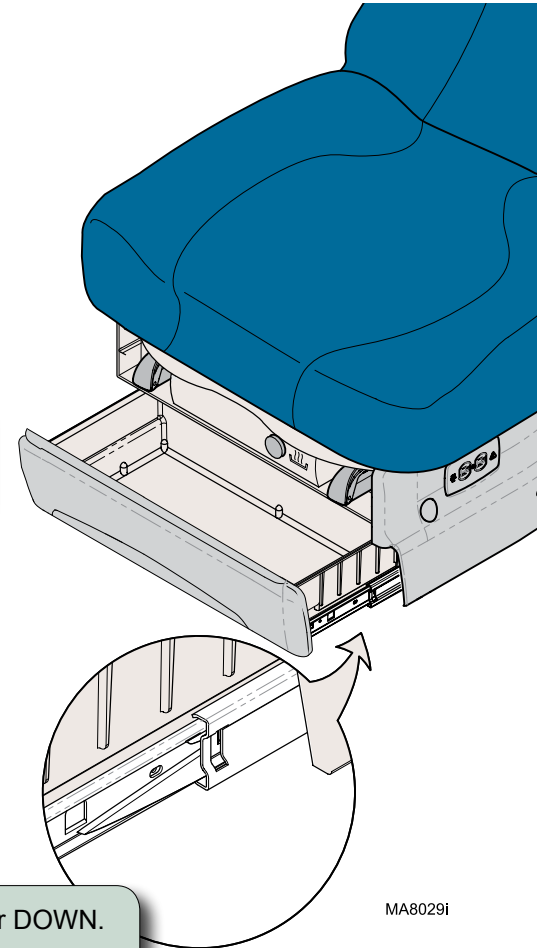

Step 2: Push LH side lever UP and RH side lever DOWN.
Remove drawer.
Note: Side levers are clear plastic.

Models:	625	
Serial Numbers:	<i>all</i>	

Table Shrouds - continued

Removal / Installation

Step 3: Lower table to lowest height.
Disconnect table power cord.

Step 4: Remove screws from head-end
& foot-end of outer shrouds.

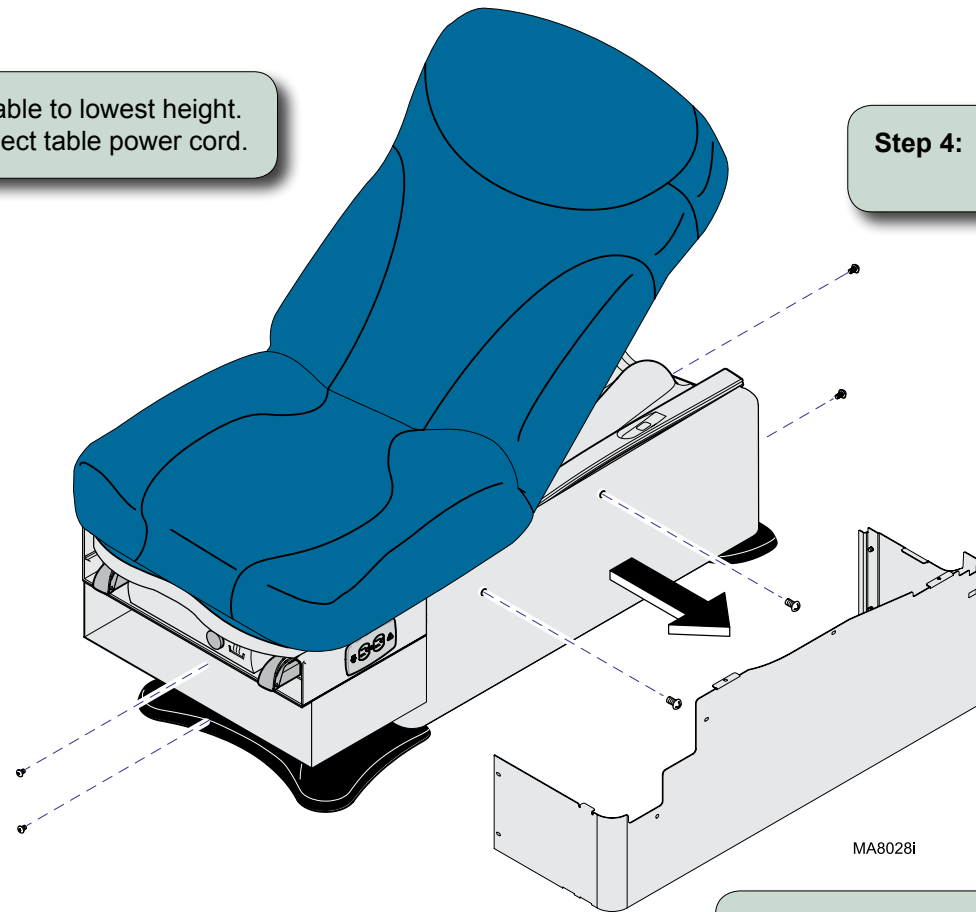

Step 5: Remove side screws & outer shroud.
Repeat for other side.

Models:	625	
Serial Numbers:	<i>all</i>	

Table Shrouds - continued

Cladding Removal / Installation C-2

Removal / Installation

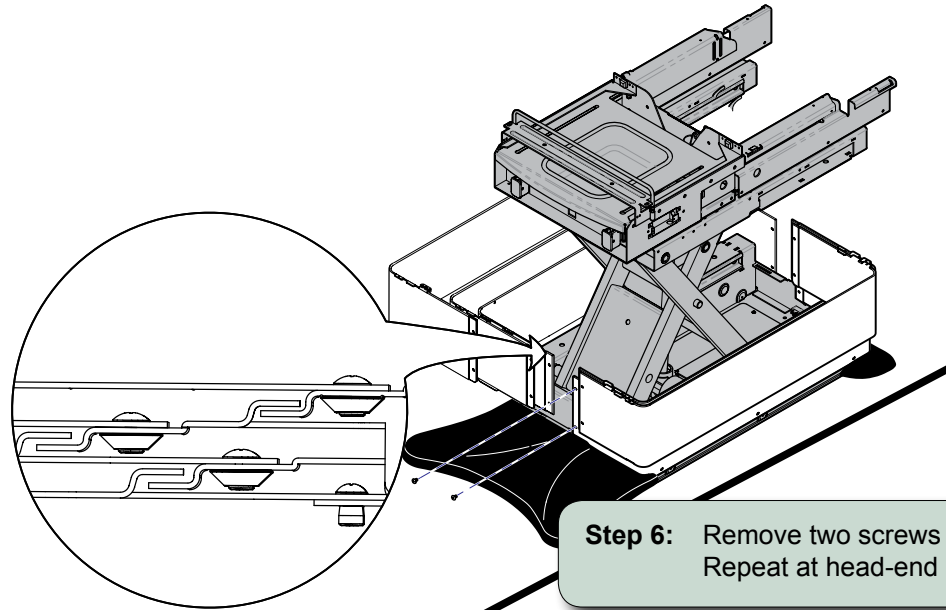

Step 6: Remove two screws securing each set of shrouds. Repeat at head-end of table.

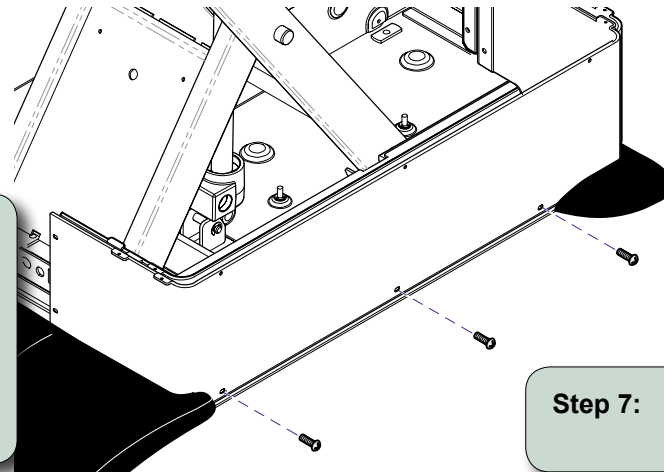

To install shrouds...

- A) Install six screws securing bottom of inner shroud.
- B) Install four screws securing each set of shrouds.
- C) Install side screws & outer shrouds.
- D) Install screws at head-end & foot-end of outer shrouds.
- E) Install drawer.
- F) Install cladding.

Step 7: Remove six screws securing bottom of inner shroud.

Models:	625
Serial Numbers:	<i>all</i>

Manually Raising / Lowering Table

[Cladding Removal / Installation.....C-2](#)
[Table Shrouds](#)
[Removal / Installation.....C-3](#)

Step 1: Remove cladding & table shrouds.
(Access procedures)

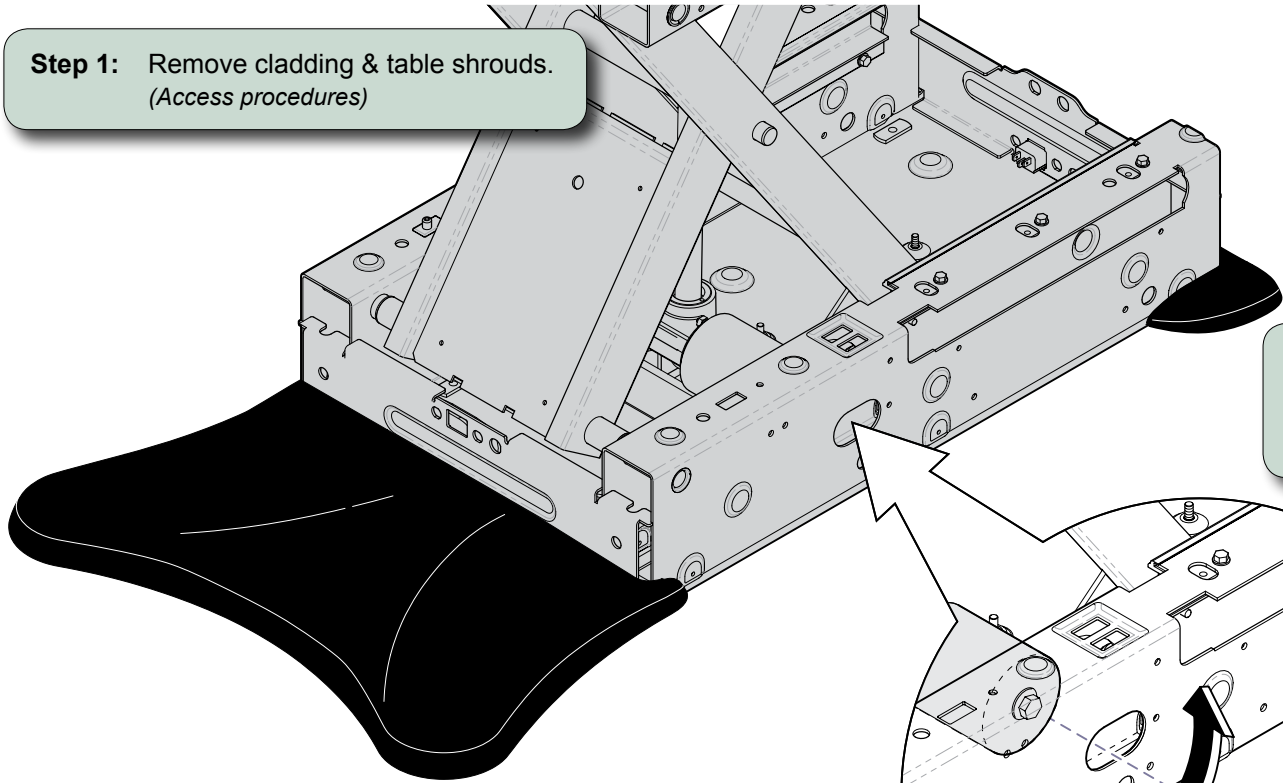

Step 2: Run drill in reverse to raise table.
Run drill forward to lower table.
Note: Requires 1/4" socket w/ extension.

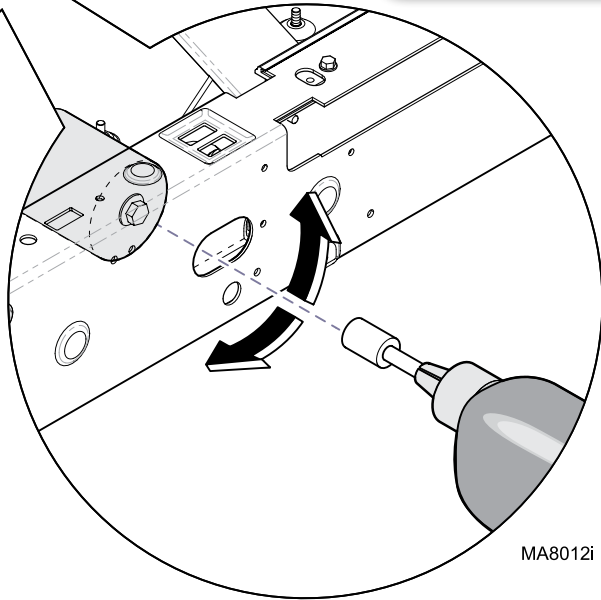

MA8012i

Models:	625	
Serial Numbers:	<i>all</i>	

Upholstered Top

Removal / Installation

Exploded Views / Part Numbers:
Premium Uph. 28 inch. Wide.....E-3
Ultra Premium Uph. 28 inch. WideE-4
Premium Uph. 32 inch. Wide.....E-5

Step 2: Remove upholstered top & footrest pad.

Note: Slide upholstery up to remove from back support plate.

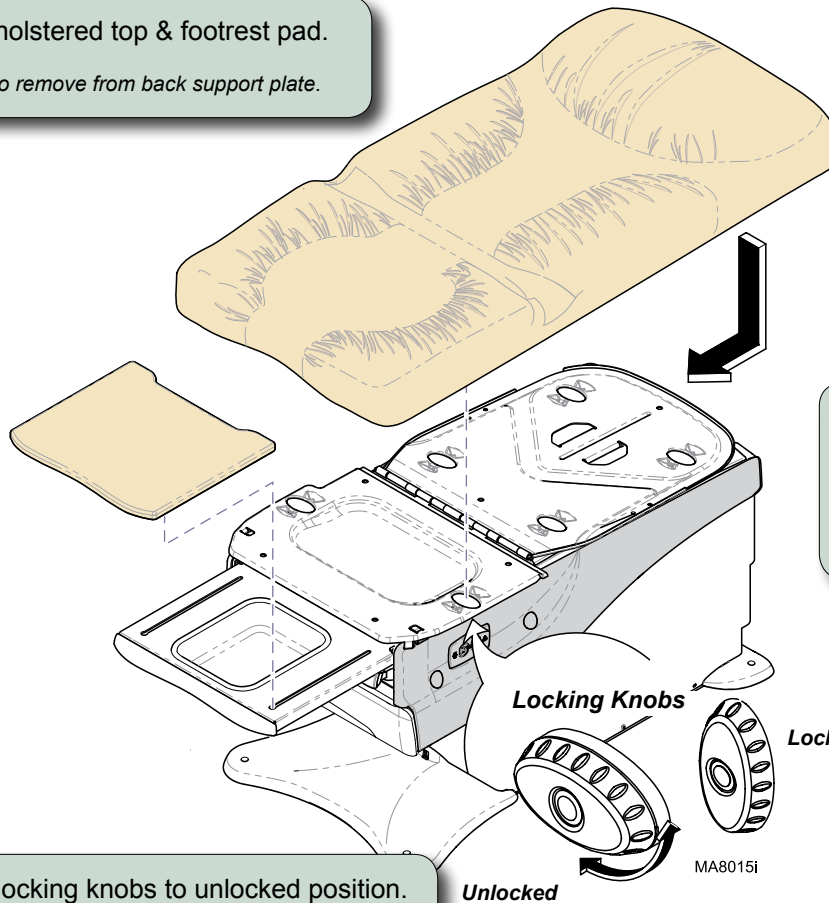

Step 3: Position upholstered top & footrest pad on table.

Note: Back support plate must slide under paper roll holder.

Be sure locking knobs align with holes in back / seat mounting plates.

Step 1: Rotate all locking knobs to unlocked position.

Note: There are four locking knobs under back section, and two locking knobs under seat section.

Step 4: Rotate locking knobs to locked position..

Models:	625
Serial Numbers:	<i>all</i>

Chair Arms / Brace (optional)

Removal

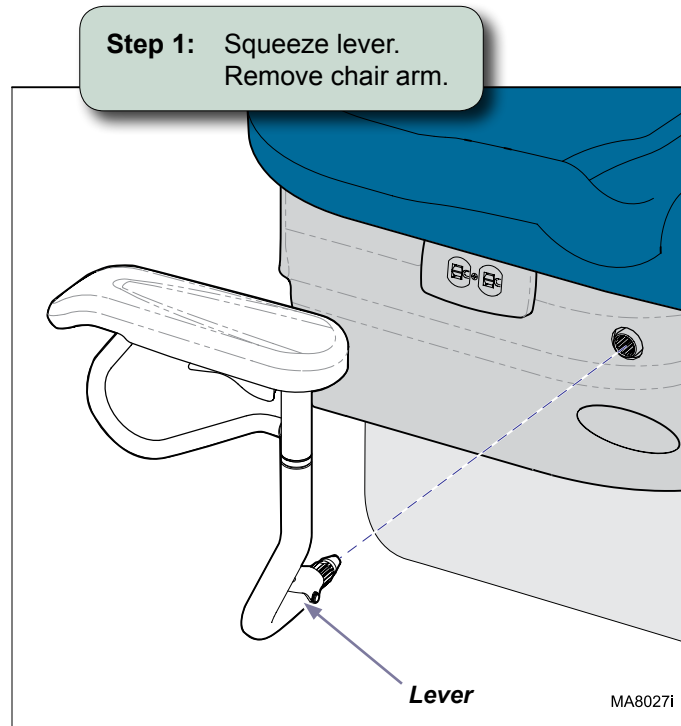

It may be necessary to remove the chair arm brace when performing certain procedures.

Step 2: Remove cladding & table shrouds.

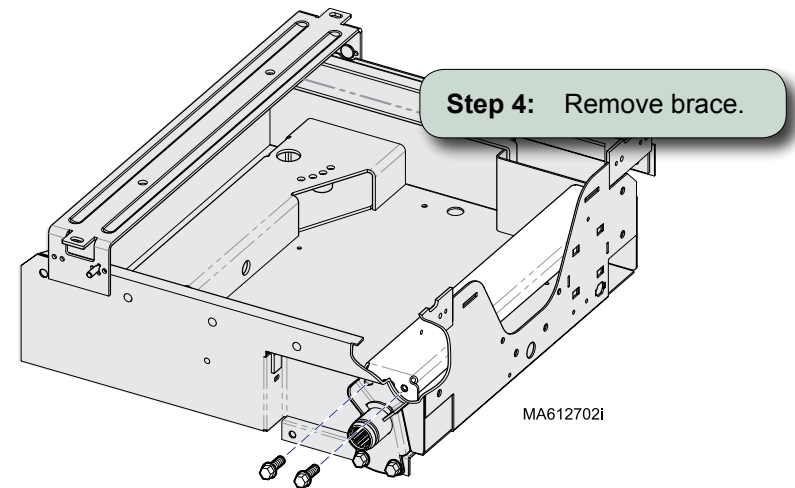

Step 3: Remove two screws.
Repeat on opposite side.

Models:	625	
Serial Numbers:	<i>all</i>	

Top Cover (Back Limit Switch Access)

[Cladding Removal / Installation.....C-2](#)
[Table Shrouds](#)
[Removal / Installation.....C-3](#)

Removal / Installation

Step 1: Remove cladding & table shrouds.

Step 6: Reattach cladding & table shrouds.

Step 2: Remove three screws securing top cover.

Step 5: Secure top cover with screws removed in Step 2.

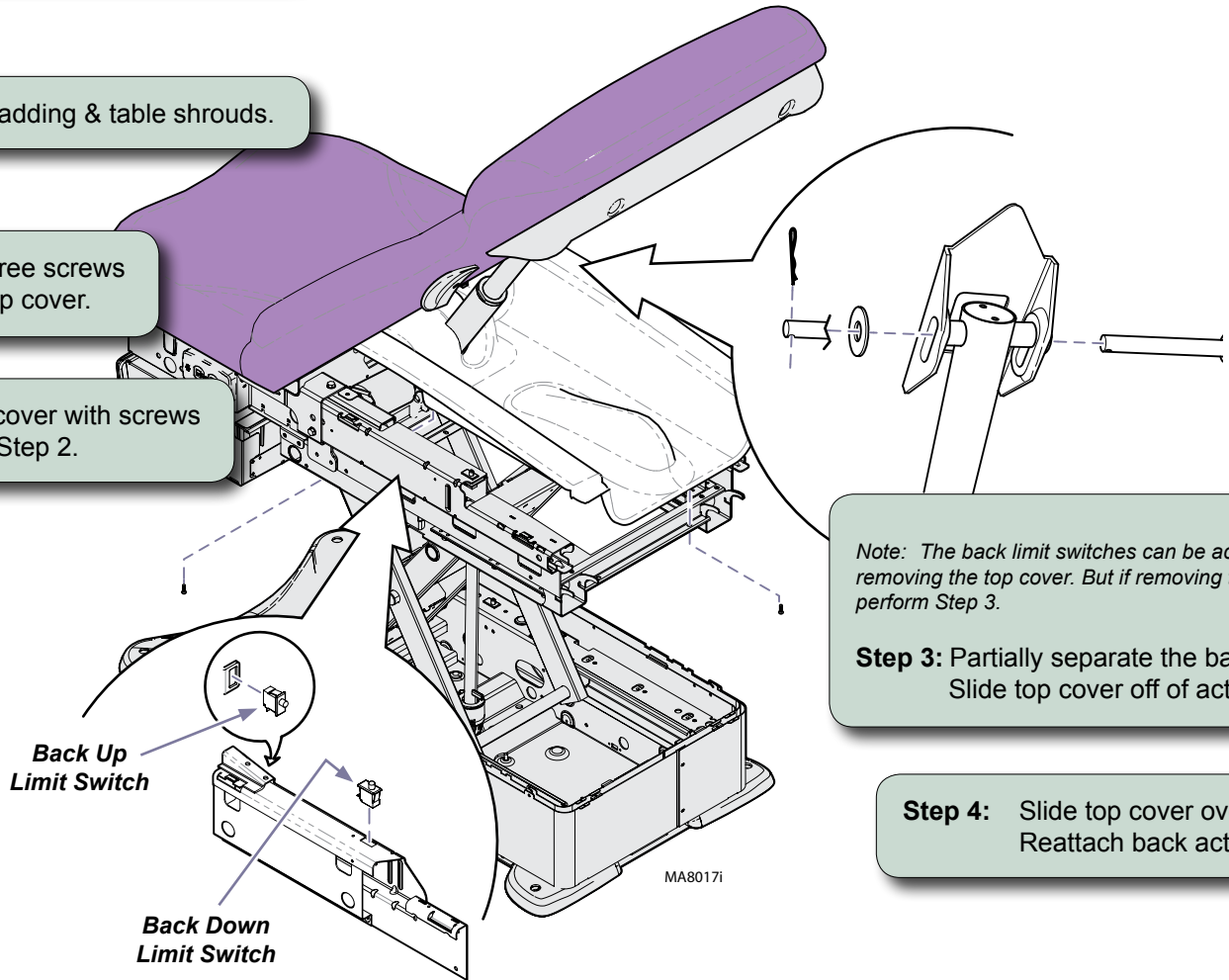

Note: The back limit switches can be accessed without completely removing the top cover. But if removing the cover is necessary, perform Step 3.

Step 3: Partially separate the back lift actuator as shown. Slide top cover off of actuator.

Step 4: Slide top cover over back actuator. Reattach back actuator.

Models:	625
Serial Numbers:	<i>all</i>

Section D

Wiring Diagrams

625-001	D-2*
625-003	D-3*
625-004	D-4
625-005	D-5
625-006	D-6

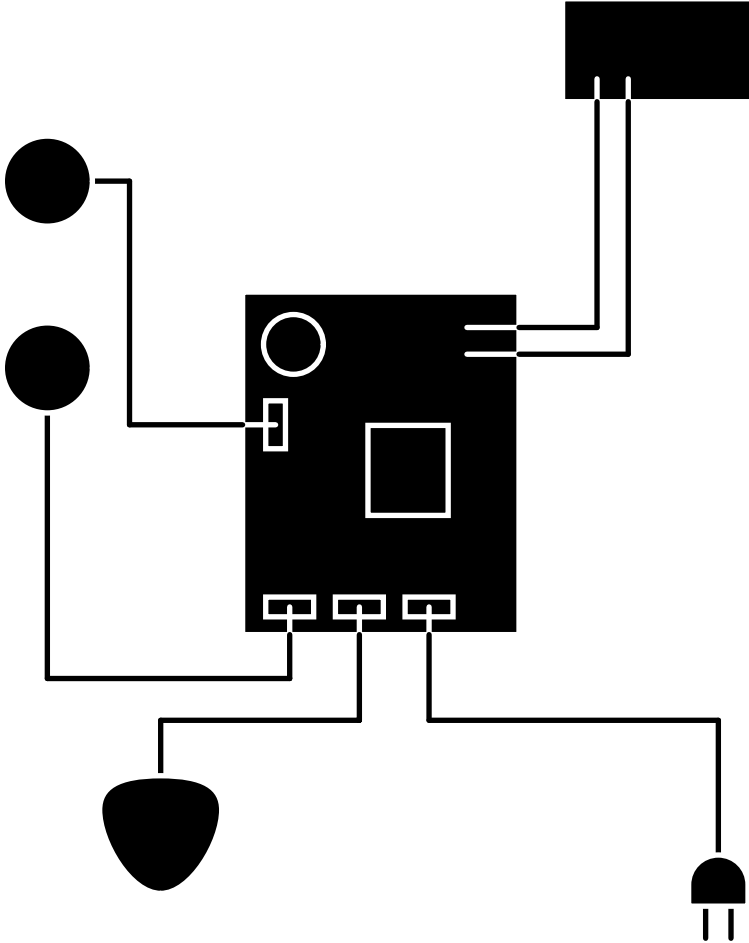

** Indicates multiple pages due to a serial number break for the wiring diagram.*

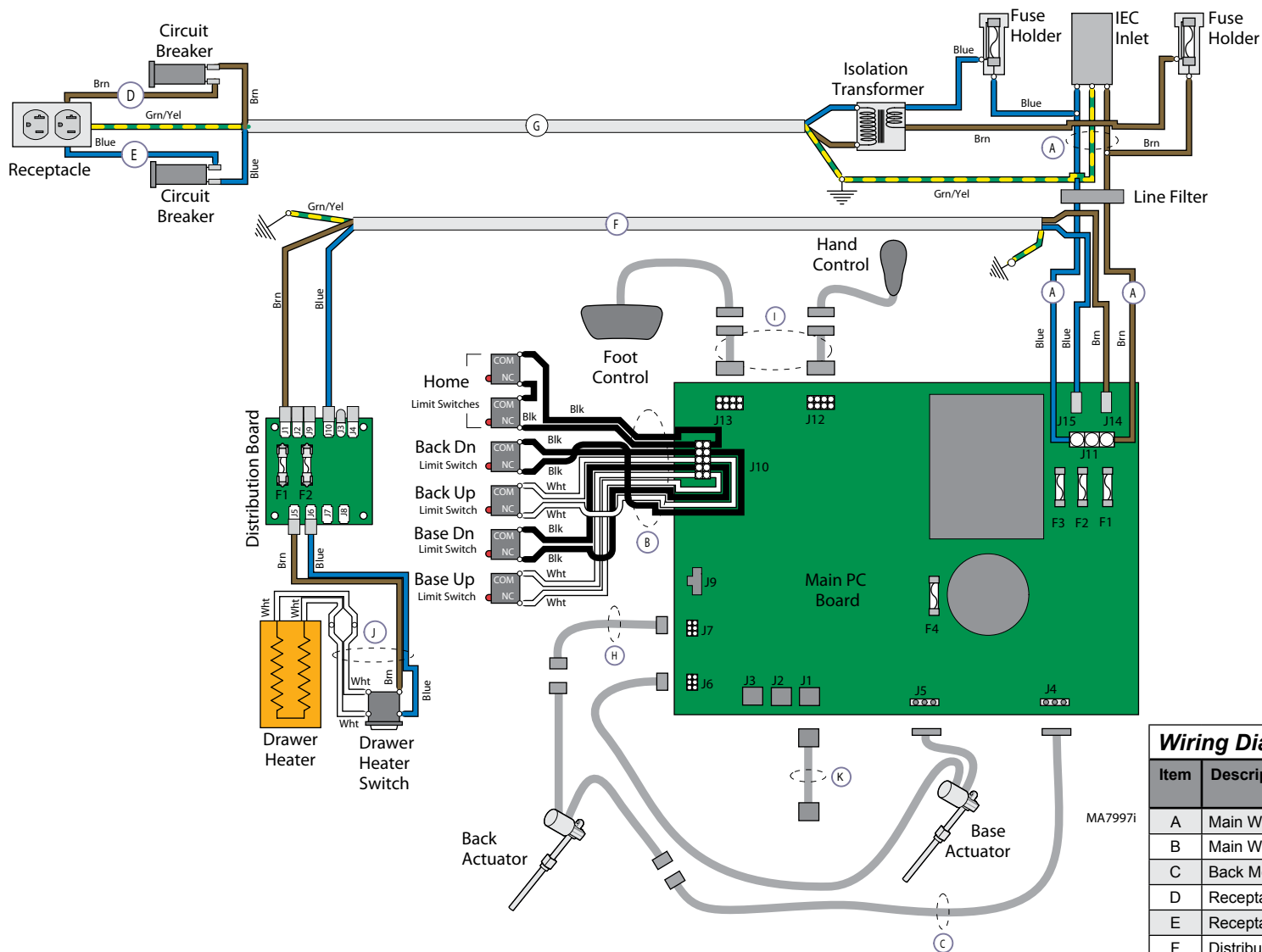

Wiring Diagram: 625 (-001)

Item	Description	Part Number
A	Main Wiring Harness	015-1854-00
B	Main Wiring Harness	015-1854-00
C	Back Motor Extension	015-2501-00
D	Receptacle Jumper (brown)	015-1886-00
E	Receptacle Jumper (blue)	015-1886-01
F	Distribution Harness	015-2005-00
G	Receptacle Harness	015-2531-00
H	Back Hall Effect Extension	015-2502-00
I	I/O Cable	015-1784-00
J	Drawer Heater Harness with Switch	015-1759-00
K	Used with wireless controls (optional)	015-2149-01

Models:	625-001
Serial Numbers:	V2200 thru V968527

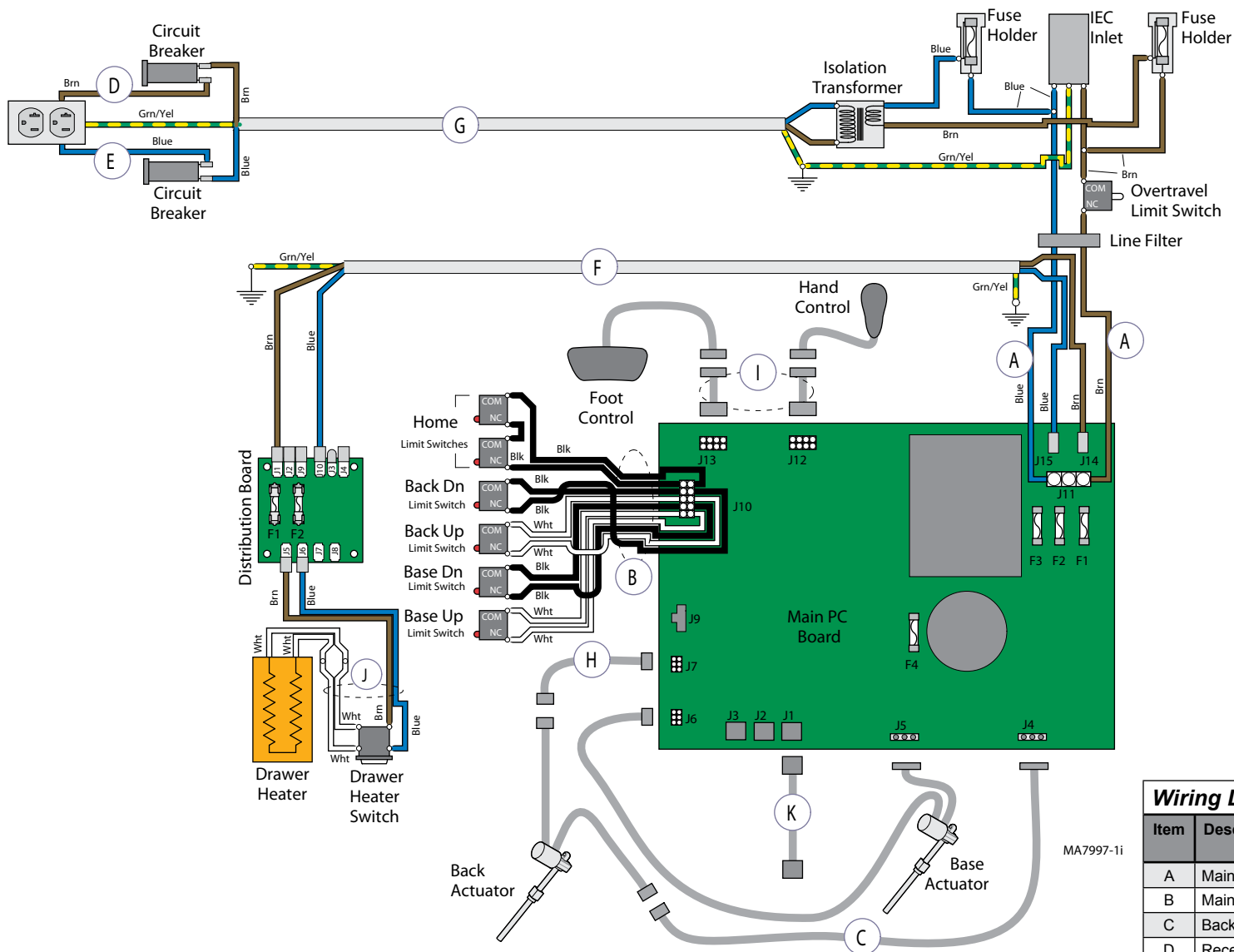

Wiring Diagram: 625 (-001)

Item	Description	Part Number
A	Main Wiring Harness	015-2812-00
B	Main Wiring Harness	015-2812-00
C	Back Motor Extension	015-2501-00
D	Receptacle Jumper (brown)	015-1886-00
E	Receptacle Jumper (blue)	015-1886-01
F	Distribution Harness	015-2005-00
G	Receptacle Harness	015-2531-00
H	Back Hall Effect Extension	015-2502-00
I	I/O Cable	015-1784-00
J	Drawer Heater Harness with Switch	015-1759-00
K	Used with wireless controls (optional)	015-2149-01

Models:	625-001
Serial Numbers:	V968528 thru V1149713

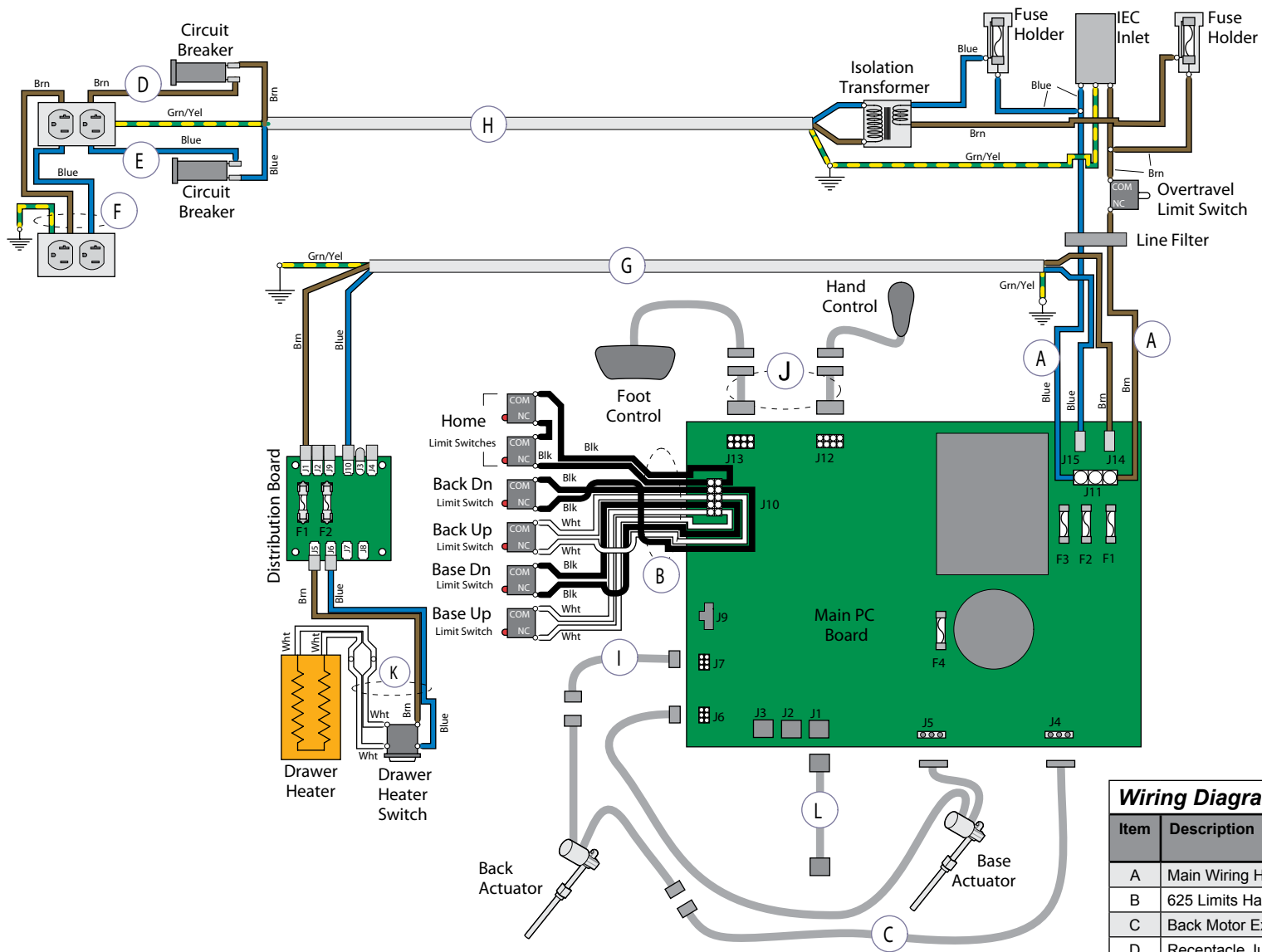

Wiring Diagram: 625 (-001)

Item	Description	Part Number
A	Main Wiring Harness	015-2812-00
B	625 Limits Harness	029-5558-01
C	Back Motor Extension	029-5558-01
D	Receptacle Jumper (brown)	015-1886-00
E	Receptacle Jumper (blue)	015-1886-01
F	Receptacle Harness, Interconnect	015-2939-00
G	Distribution Harness	029-5558-01
H	Receptacle Harness	029-5558-01
I	Back Hall Effect Extension	029-5558-01
J	I/O Cable	015-1784-00
K	Drawer Heater Harness with Switch	015-1759-00
L	Used with wireless controls (optional)	029-5558-01

Models:	625-001
Serial Numbers:	V1149714 thru Present

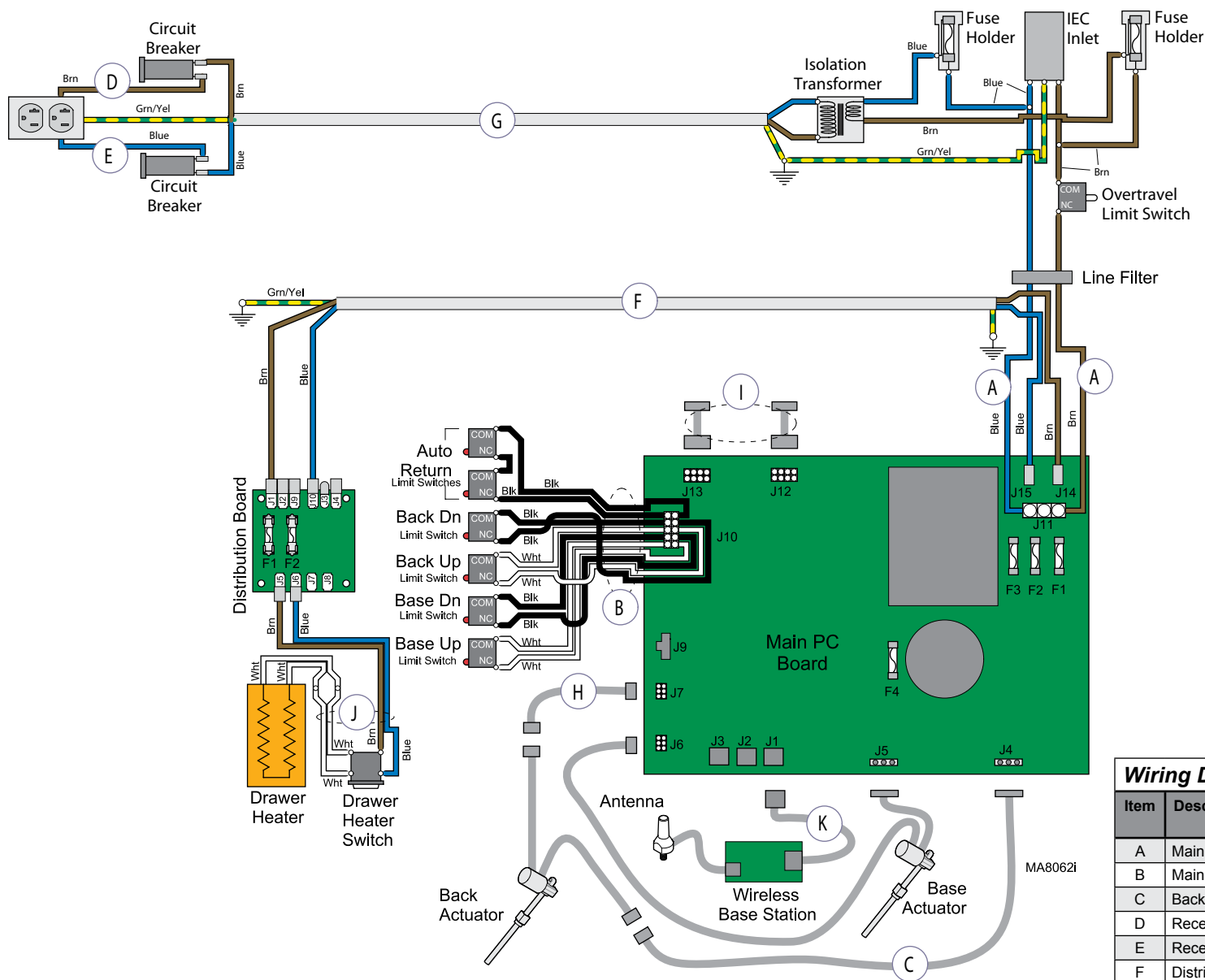

Wiring Diagram: 625 (-003)

Item	Description	Part Number
A	Main Wiring Harness	015-2812-00
B	Main Wiring Harness	015-2812-00
C	Back Motor Extension	015-2501-00
D	Receptacle Jumper (brown)	015-1886-00
E	Receptacle Jumper (blue)	015-1886-01
F	Distribution Harness	015-2005-00
G	Receptacle Harness	015-2531-00
H	Back Hall Effect Extension	015-2502-00
I	I/O Cable	015-1784-00
J	Drawer Heater Harness with Switch	015-1759-00
K	Modular Harness (straight)	015-2149-01

Models:	625-003
Serial Numbers:	V2200 thru V1149713

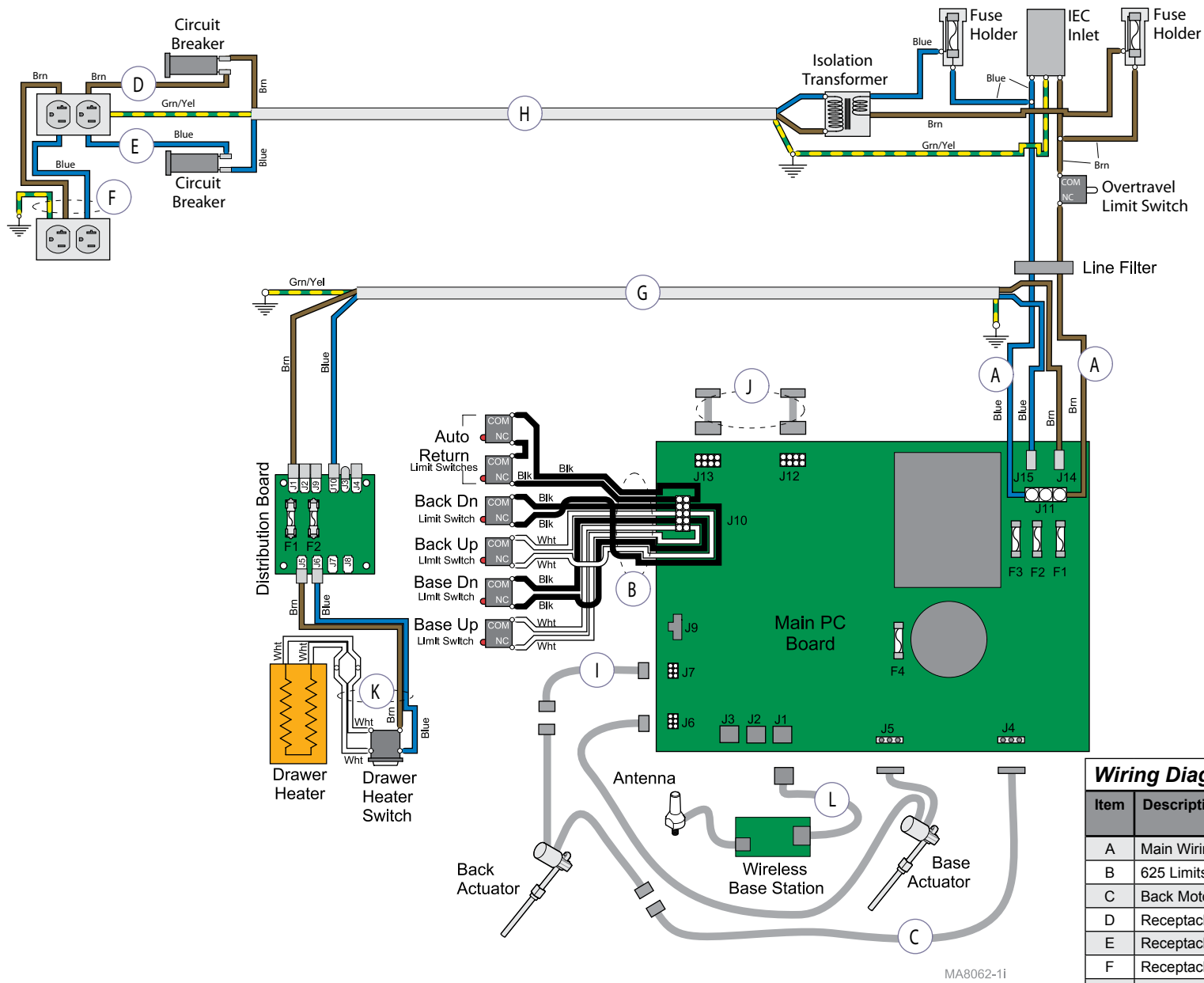

Wiring Diagram: 625 (-003)

Item	Description	Part Number
A	Main Wiring Harness	015-2812-00
B	625 Limits Harness	029-5558-01
C	Back Motor Extension	029-5558-01
D	Receptacle Jumper (brown)	015-1886-00
E	Receptacle Jumper (blue)	015-1886-01
F	Receptacle Harness, Interconnect	015-2939-00
G	Distribution Harness	029-5558-01
H	Receptacle Harness	029-5558-01
I	Back Hall Effect Extension	029-5558-01
J	I/O Cable	015-1784-00
K	Drawer Heater Harness with Switch	015-1759-00
L	Modular Harness (straight)	029-5558-01

Models: 625-003
Serial Numbers: V1149714 thru Present

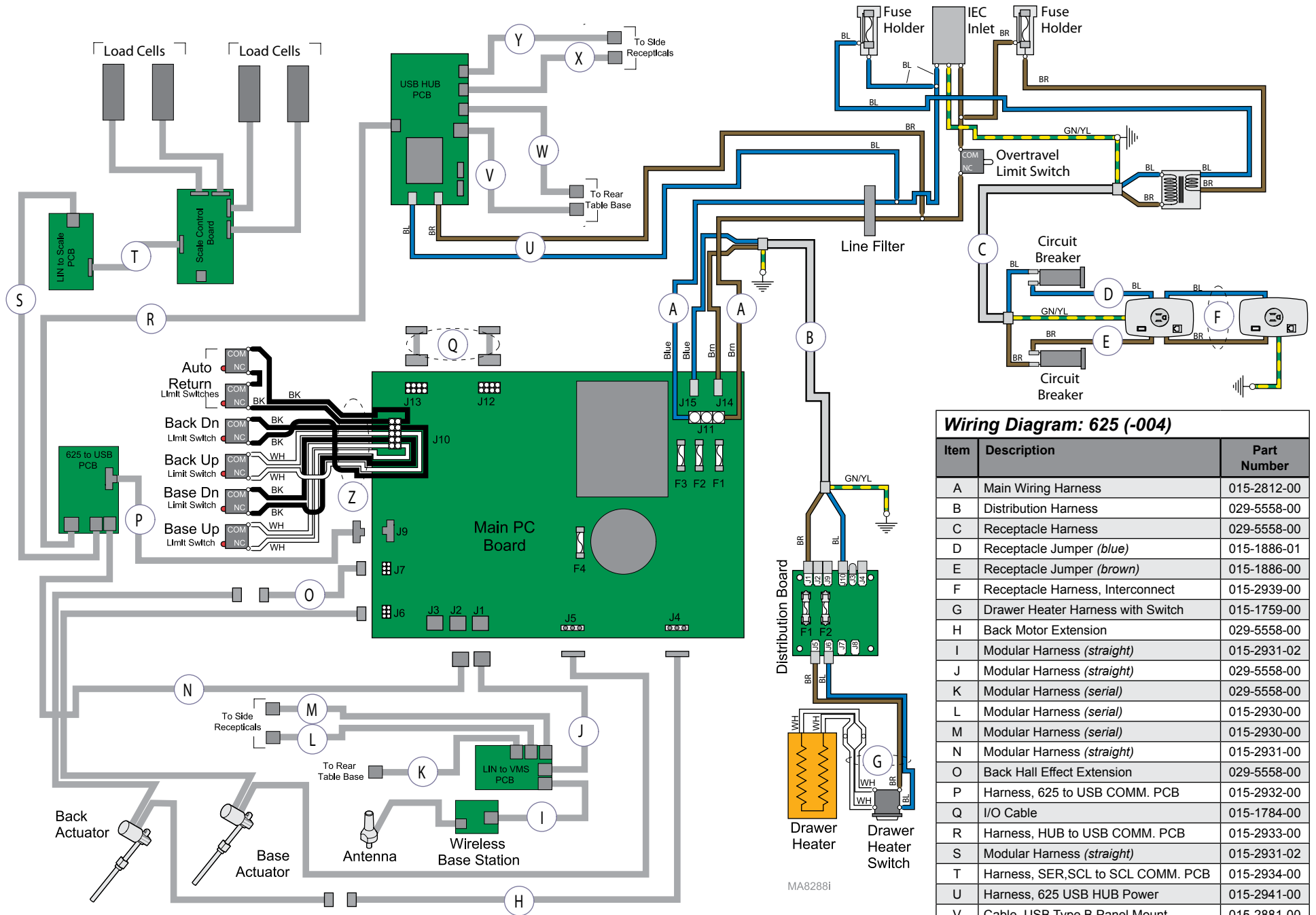

Wiring Diagram: 625 (-004)

Item	Description	Part Number
A	Main Wiring Harness	015-2812-00
B	Distribution Harness	029-5558-00
C	Receptacle Harness	029-5558-00
D	Receptacle Jumper (blue)	015-1886-01
E	Receptacle Jumper (brown)	015-1886-00
F	Receptacle Harness, Interconnect	015-2939-00
G	Drawer Heater Harness with Switch	015-1759-00
H	Back Motor Extension	029-5558-00
I	Modular Harness (straight)	015-2931-02
J	Modular Harness (straight)	029-5558-00
K	Modular Harness (serial)	029-5558-00
L	Modular Harness (serial)	015-2930-00
M	Modular Harness (serial)	015-2930-00
N	Modular Harness (straight)	015-2931-00
O	Back Hall Effect Extension	029-5558-00
P	Harness, 625 to USB COMM. PCB	015-2932-00
Q	I/O Cable	015-1784-00
R	Harness, HUB to USB COMM. PCB	015-2933-00
S	Modular Harness (straight)	015-2931-02
T	Harness, SER,SCL to SCL COMM. PCB	015-2934-00
U	Harness, 625 USB HUB Power	015-2941-00
V	Cable, USB Type B Panel Mount	015-2881-00
W	Cable, USB Type A Panel Mount	015-2458-00
X	Cable, USB Type A Panel Mount	029-5558-00
Y	Cable, USB Type A Panel Mount	029-5558-00
Z	Distribution Harness	029-5558-00

Models: 625-004
Serial Numbers: all

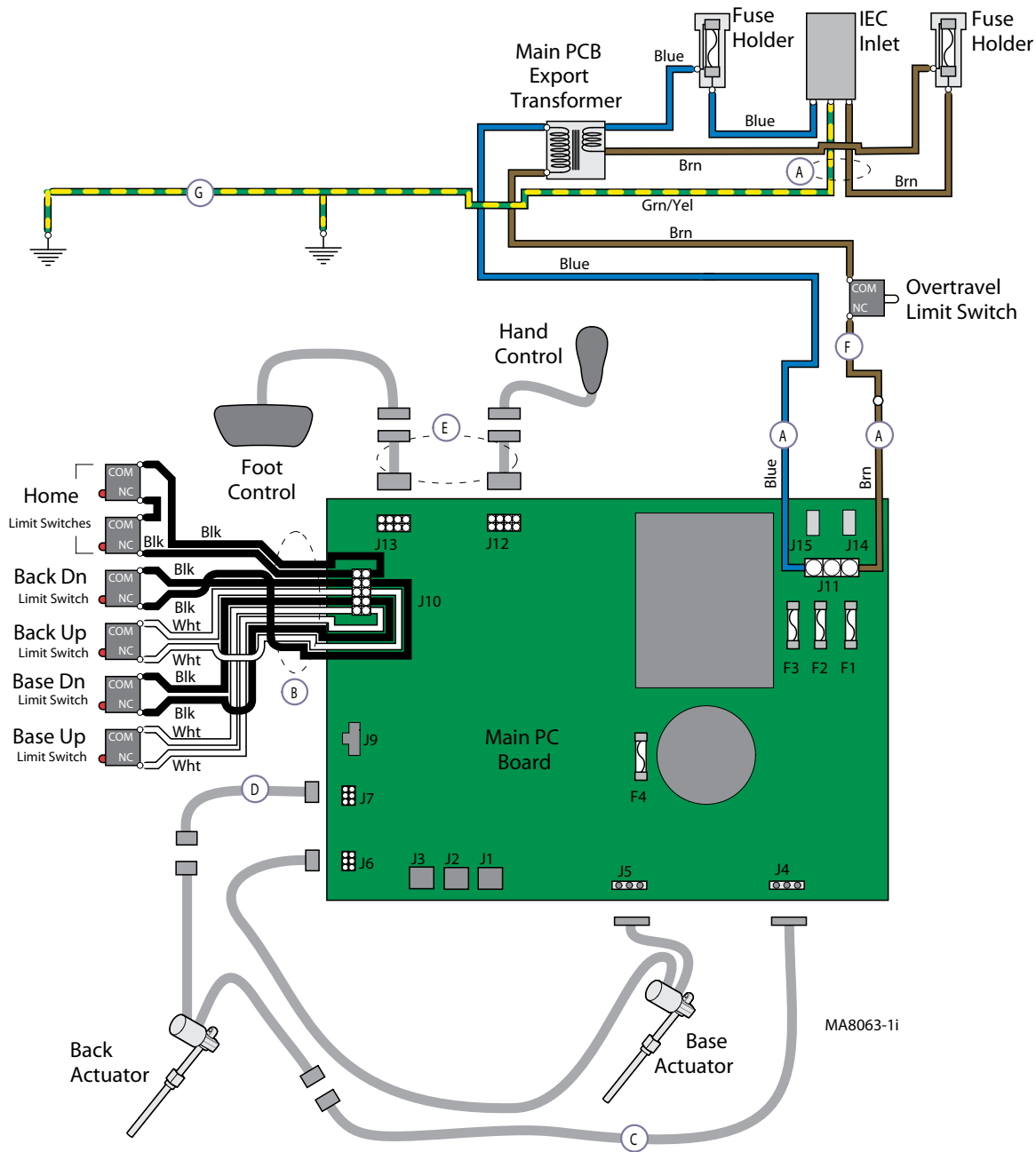

Models:	625-005
Serial Numbers:	<i>all</i>

Wiring Diagram: 625 (-005)		
Item	Description	Part Number
A	Main Wiring Harness	015-2812-00
B	Main Wiring Harness	015-2812-00
C	Back Motor Extension	015-2501-00
D	Back Hall Effect Extension	015-2502-00
E	I/O Cable	015-1784-00
F	Power Interrupt Harness	015-2813-00
G	Ground Harness	015-2570-00

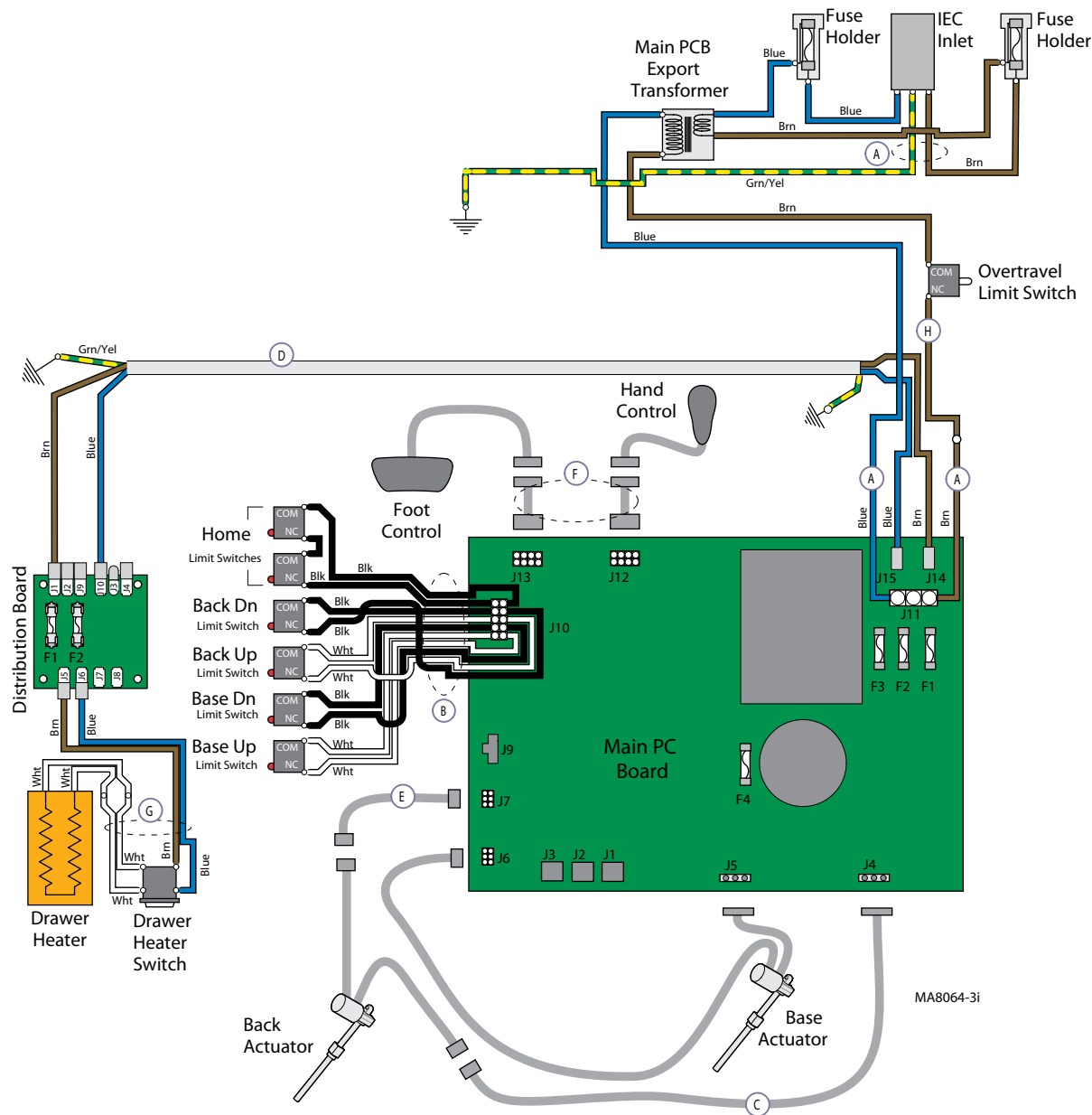

Wiring Diagram: 625 (-006)

Item	Description	Part Number
A	Main Wiring Harness	015-2812-00
B	Main Wiring Harness	015-2812-00
C	Back Motor Extension	015-2501-00
D	Distribution Harness	015-2005-00
E	Back Hall Effect Extension	015-2502-00
F	I/O Cable	015-1784-00
G	Drawer Heater Harness with Switch	015-1759-00
H	Power Interrupt Harness	015-2813-00

Models:	625-006
Serial Numbers:	<i>all</i>

Section E

Exploded Views & Parts Lists

625
(-001 /-003 /-004 /-005 /-006).....E-2

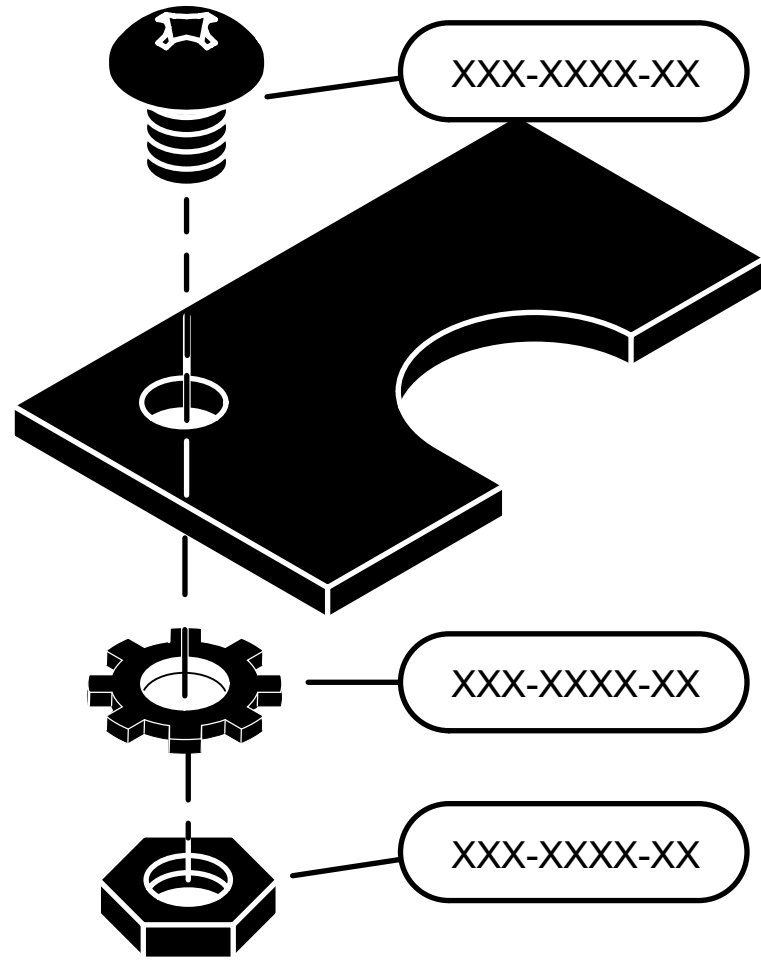

Upholstery:
Premium: 28 in. wide.....E-3
Ultra-Premium: 28 in. wide.....E-4
Premium: 32 in. wide.....E-5

Seat Section.....E-6
Pelvic Tilt.....E-8

Stirrups.....E-7

Exam Assistant® Drawer Assy..... E-11

Base Components..... E-15*

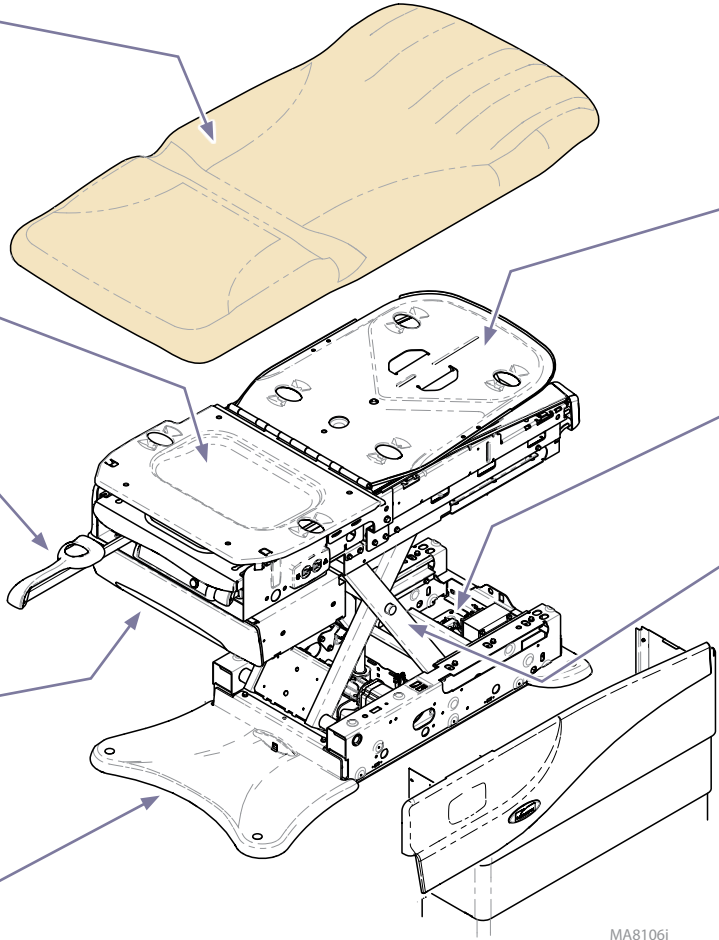

Optional:
Table Receptacle System..... E-25*
Drawer Heater System.....E-27

Actuators / Limit Switches:
Base..... E-14*
Back..... E-10*

Back Section..... E-9*

Electrical Components..... E-16*
Fuses.....E-24

Base Scissor / Slide Mechanism.....E-13

Base Shrouds / Side Cladding..... E-12*

Scale / USB Boards.....E-17

Foot Control.....E-18
Hand Control.....E-19

Wireless Controls.....E-20

Models:	625
Serial Numbers:	<i>all</i>

* Indicates multiple pages due to a serial number break for the parts illustration.

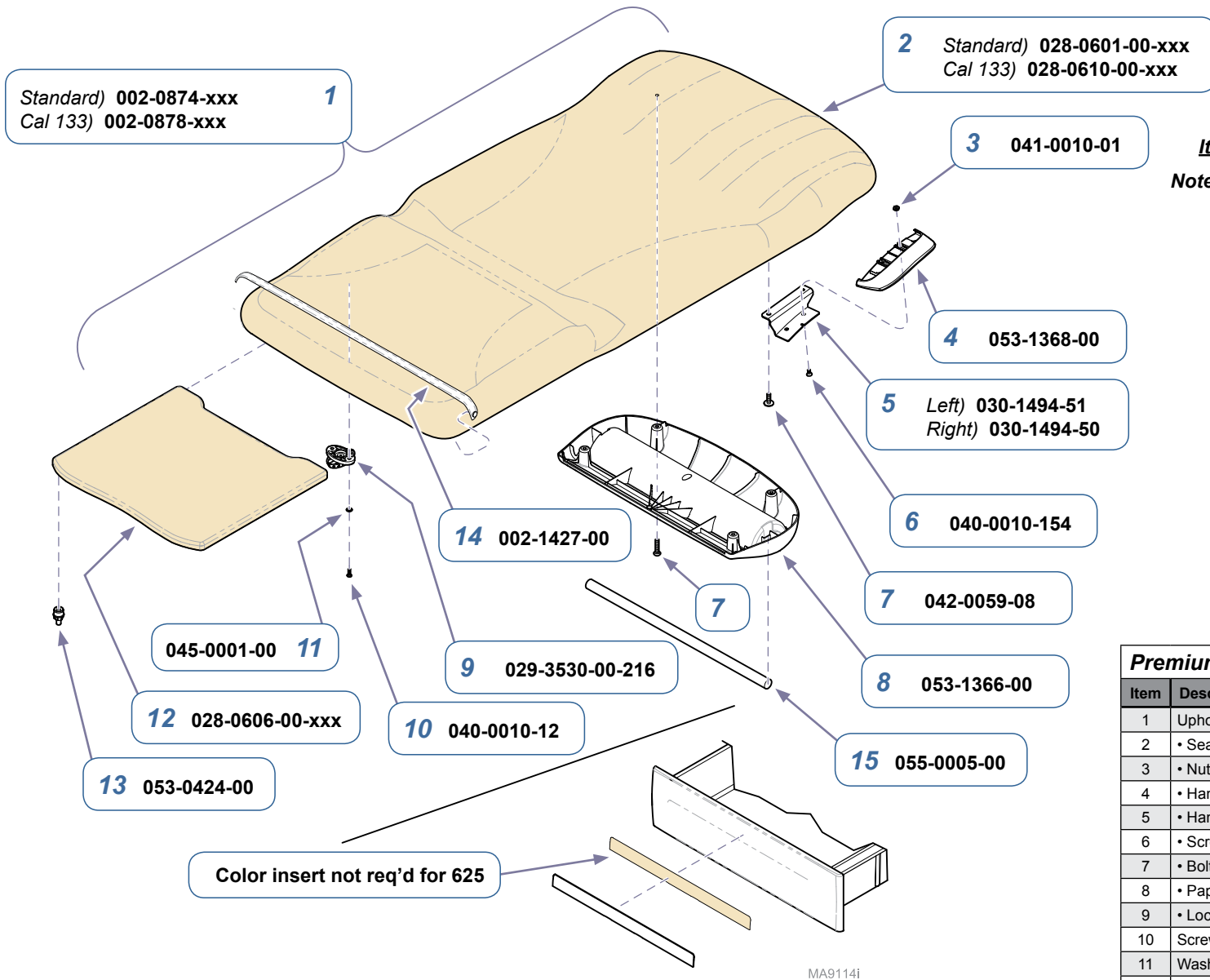

Item #16 is a special order option.

Note: The footrest shelf will not slide into the stowed position with this pad installed.

16 Standard) 002-0897-02-xxx
PVC Free) 002-1135-xxx

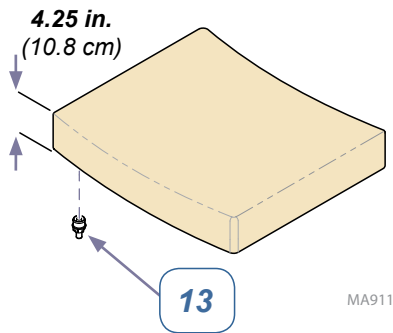

Premium Upholstery: 28 Inch Wide

Item	Description	Qty.
1	Upholstery Set (includes items 2 thru 13)	1
2	• Seat / Back Upholstery	1
3	• Nut	4
4	• Handle	2
5	• Handle Bracket	2
6	• Screw	4
7	• Bolt (1/4-20 x .787")	8
8	• Paper Roll Housing	1
9	• Locking Knob	6
10	Screw	12
11	Washer	12
12	• Footrest Pad (includes item 13 - qty 4)	1
13	•• Footrest Glide	4
14	Tear Strap	1
15	Paper Roll Rod	1
16	Footrest Pad - special (4.25 in. thick) [includes four glides (item #13)]	1

Models:	625
Serial Numbers:	all

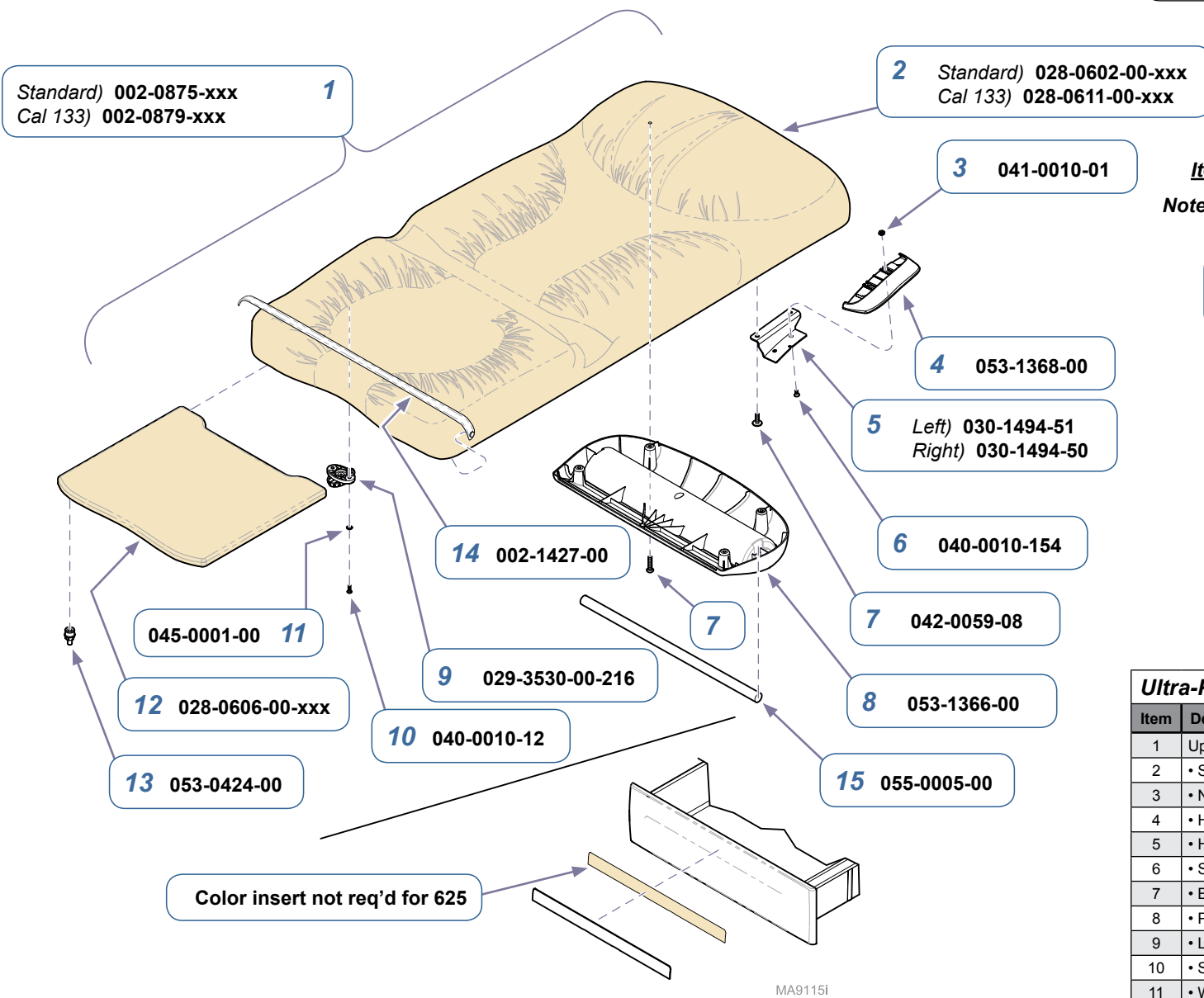

Item #16 is a special order option.
Note: The footrest shelf will not slide into the stowed position with this pad installed.

16 Standard) 002-0897-02-xxx
 PVC Free) 002-1135-xxx

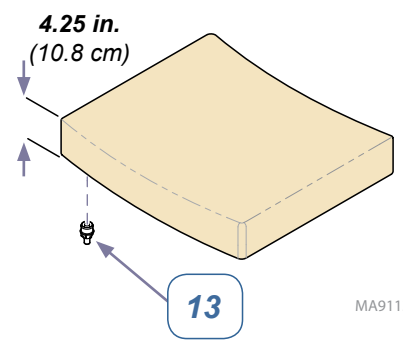

Ultra-Premium Upholstery: 28 Inch Wide

Item	Description	Qty.
1	Upholstery Set (includes items 2 thru 14)	1
2	• Seat / Back Upholstery	1
3	• Nut	4
4	• Handle	2
5	• Handle Bracket	2
6	• Screw	4
7	• Bolt (1/4-20 x .787")	8
8	• Paper Roll Housing	1
9	• Locking Knob	6
10	• Screw	12
11	• Washer	12
12	• Footrest Pad (includes item 13 - qty 4)	1
13	• • Footrest Glide	4
14	Tear Strap	1
15	Paper Roll Rod	1
16	Footrest Pad - special (4.25 in. thick) [includes four glides (item #13)]	1

Models:	625
Serial Numbers:	all

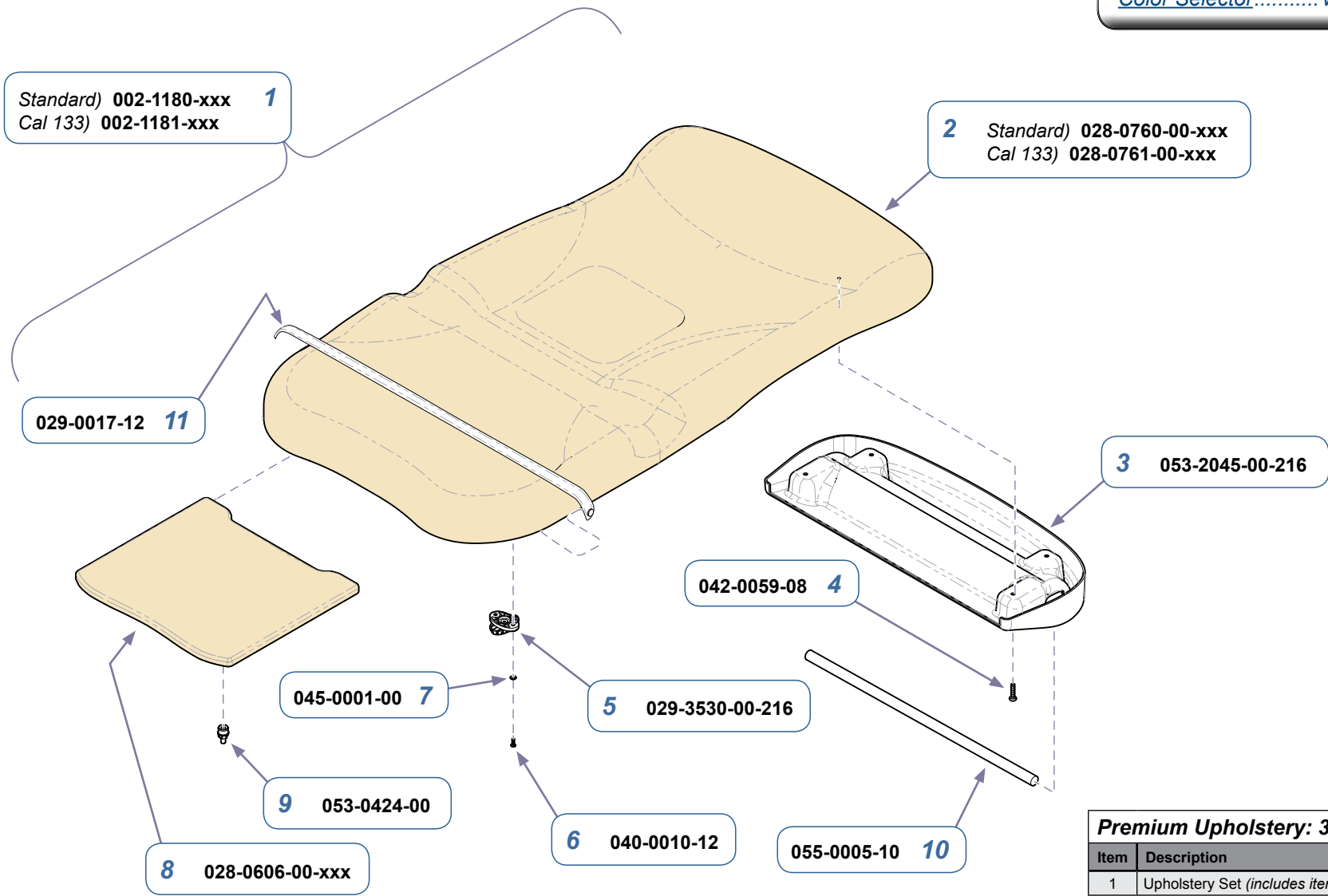

Premium Upholstery: 32 Inch Wide		
Item	Description	Qty.
1	Upholstery Set (includes items 2 thru 10)	1
2	• Seat / Back Upholstery	1
3	• Paper Roll Housing	1
4	• Screw	4
5	• Locking Knob	6
6	• Screw	12
7	• Washer	12
8	• Footrest Pad (includes item 9 - qty 4)	1
9	• • Footrest Glide	4
10	• Paper Roll Rod	1
11	Tear Strap	2

Models:	625	
Serial Numbers:	<i>all</i>	

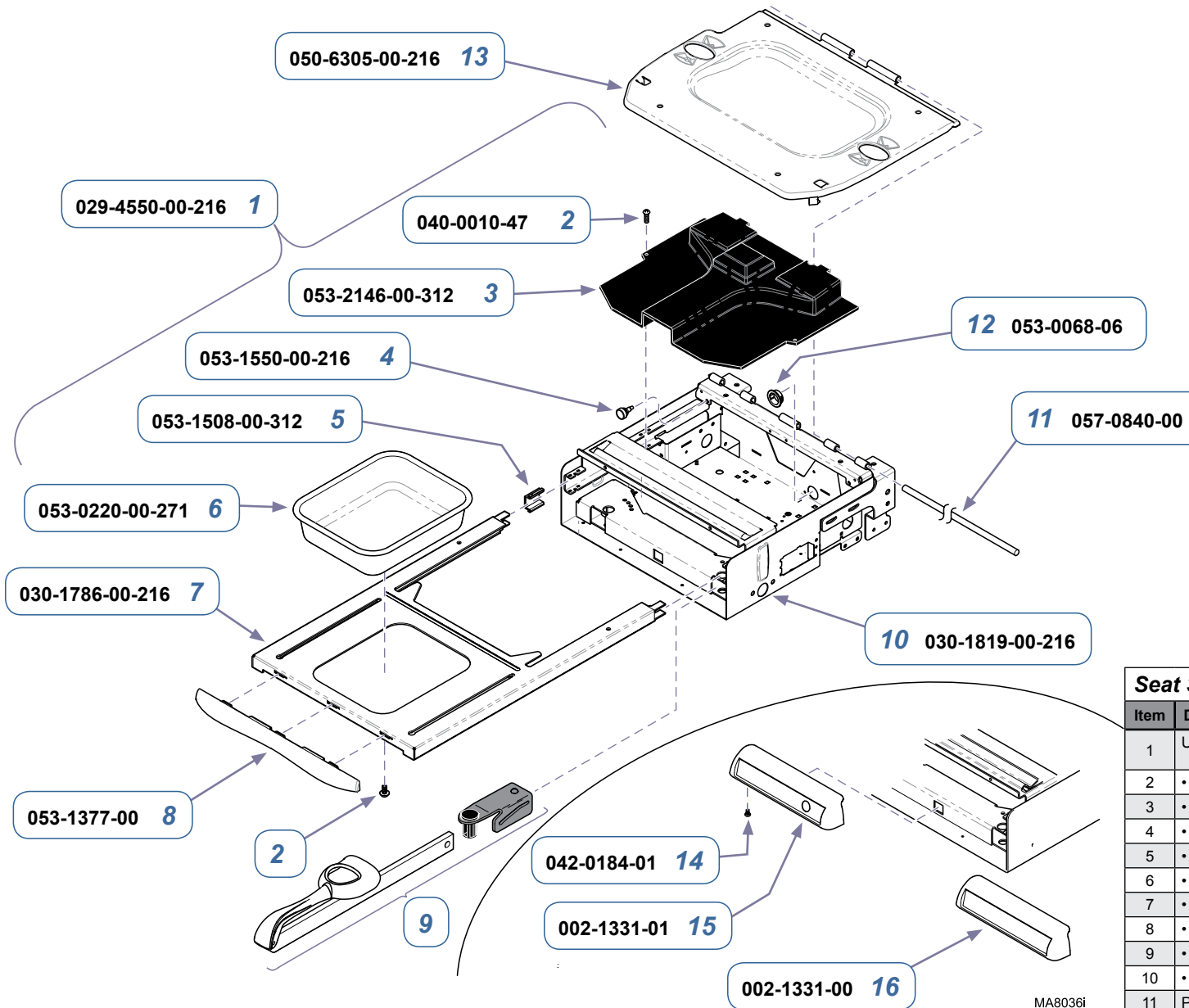

Seat Section		
Item	Description	Qty.
1	Upperwrap Assembly <i>(includes items 2 thru 10)</i>	1
2	• Screw (#10-24 x 3/8")	6
3	• Stirrup Guide	1
4	• Stem Bumper	4
5	• Runner Glide	4
6	• Plastic Treatment Pan	1
7	• Footrest Shelf	1
8	• Footrest Trim	1
9	• Refer to: "Stirrup Assembly"	2
10	• Upperwrap Weldment	1
11	Pivot Rod	1
12	Snap Bushing	3
13	Seat Mtg. Frame	1
14	Screw	2
15	Switch Housing and Label Kit <i>(with one switch hole [includes label])</i>	1
16	Switch Housing and Label Kit <i>(no holes [includes label])</i>	1

Models:	625
Serial Numbers:	<i>all</i>

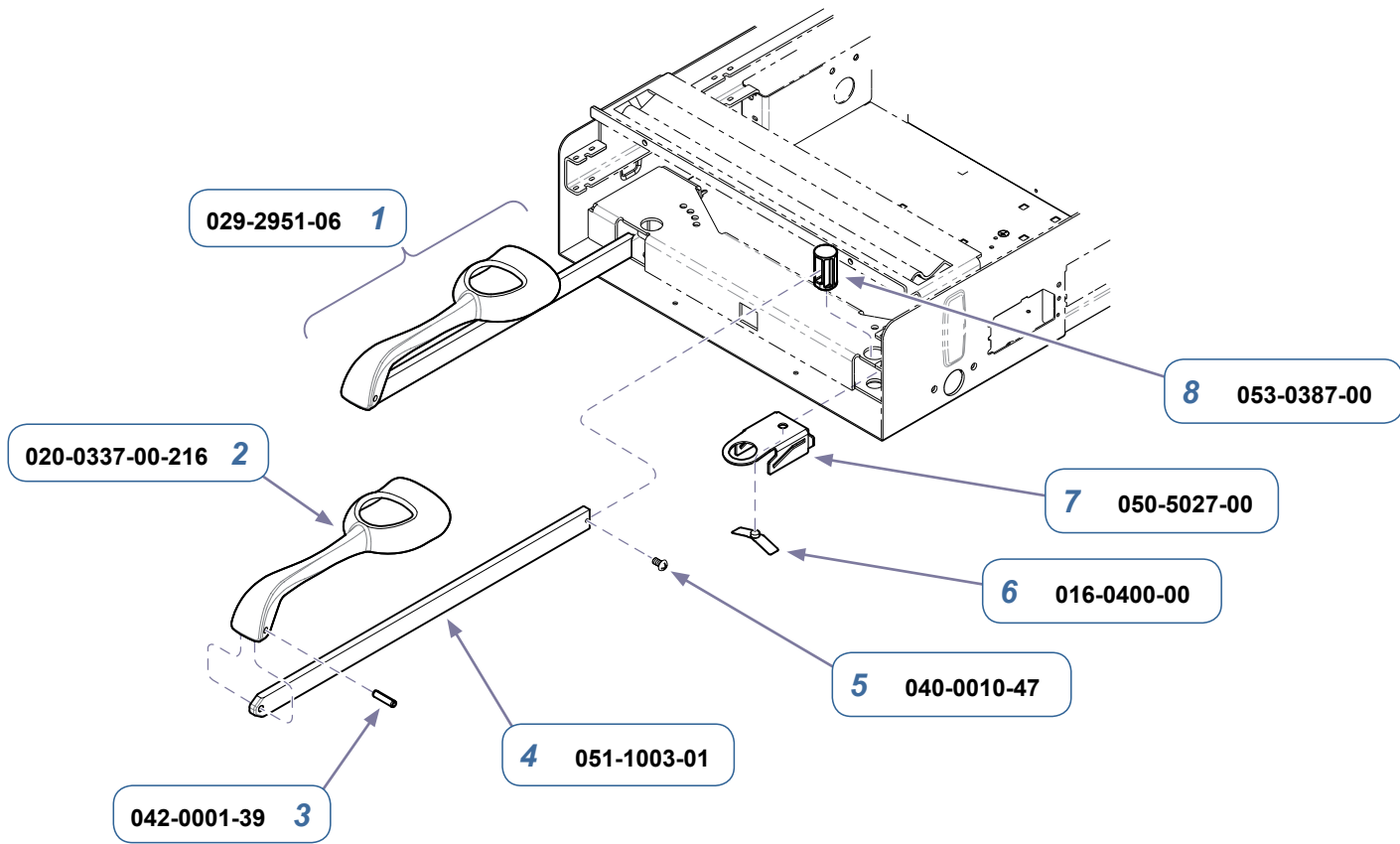

MA7039001

Models:	625
Serial Numbers:	<i>all</i>

Stirrups		
Item	Description	Qty.
1	Stirrup Assembly <i>(includes items 2 thru 4)</i>	2
2	• Stirrup	1
3	• Roll Pin	1
4	• Stirrup Bar	1
5	Screw <i>(10-24 x 3/8")</i>	2
6	Guide Bracket Spring	2
7	Guide Bracket	2
8	Pivot Boss	2

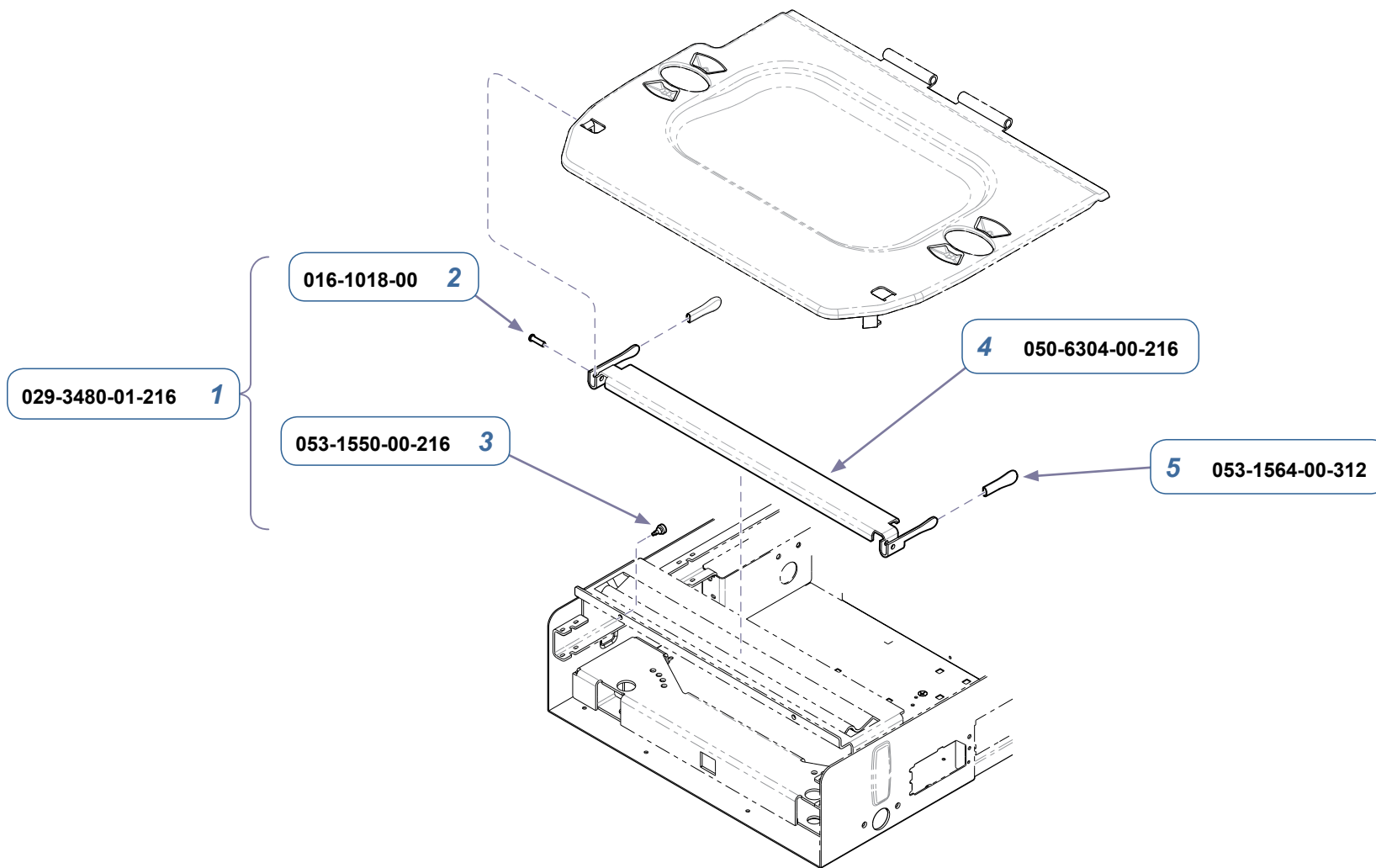

MA716200i

Models:	625
Serial Numbers:	<i>all</i>

Pelvic Tilt		
Item	Description	Qty.
1	Pelvic Tilt Assembly <i>(includes items 2 thru 5)</i>	1
2	• Pivot Pin	2
3	• Bumper	2
4	• Bracket	1
5	• Handle	2

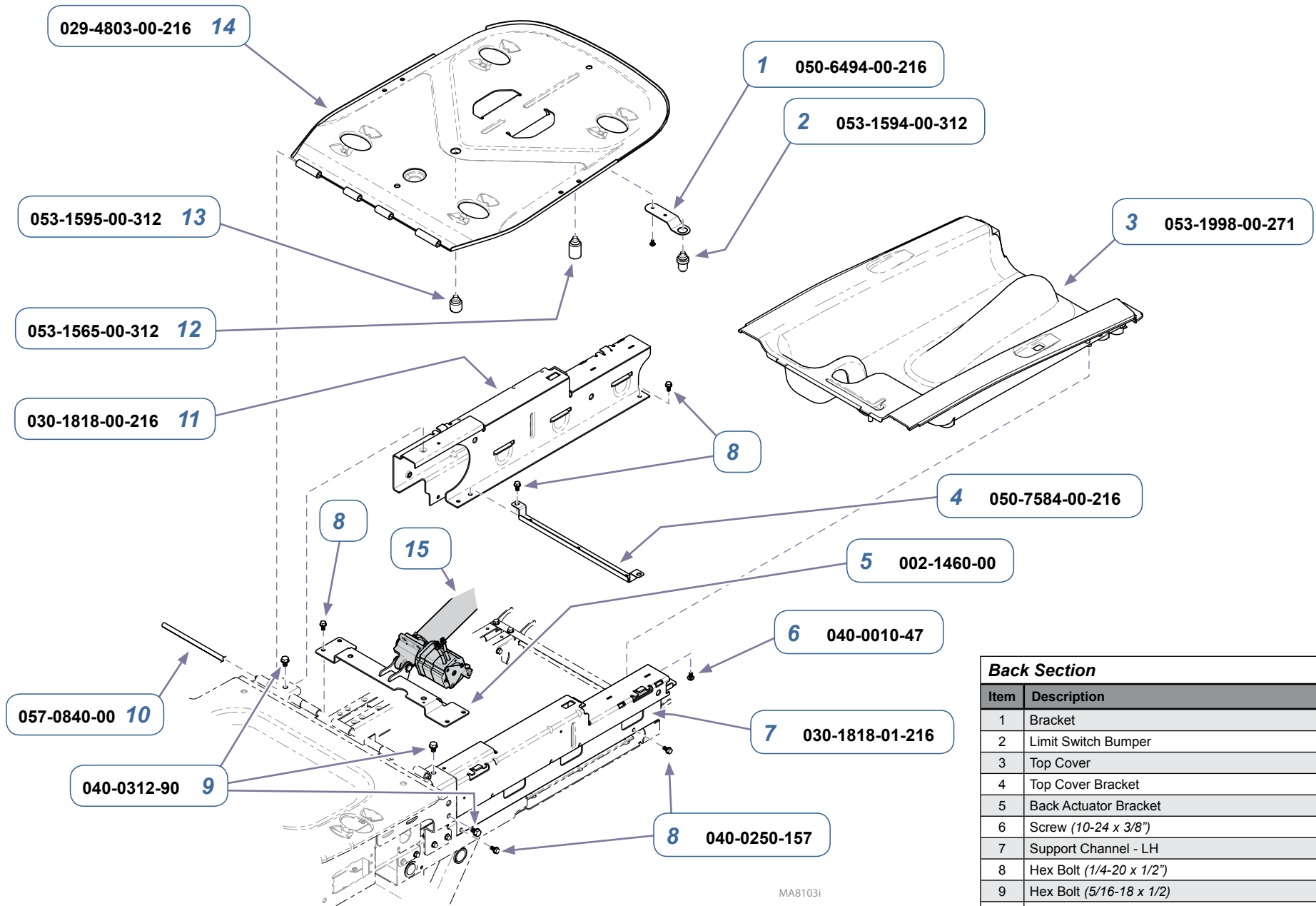

Back Section		
Item	Description	Qty.
1	Bracket	1
2	Limit Switch Bumper	1
3	Top Cover	1
4	Top Cover Bracket	1
5	Back Actuator Bracket	1
6	Screw (10-24 x 3/8")	2
7	Support Channel - LH	1
8	Hex Bolt (1/4-20 x 1/2")	14
9	Hex Bolt (5/16-18 x 1/2")	4
10	Hinge Rod	1
11	Support Channel - RH	1
12	Bumper	2
13	Bumper	1
14	Back Weldment	1
15	Refer to: "Back Actuator / Limit Switches"	Ref

Models:	625
Serial Numbers:	V2200 thru V1083261

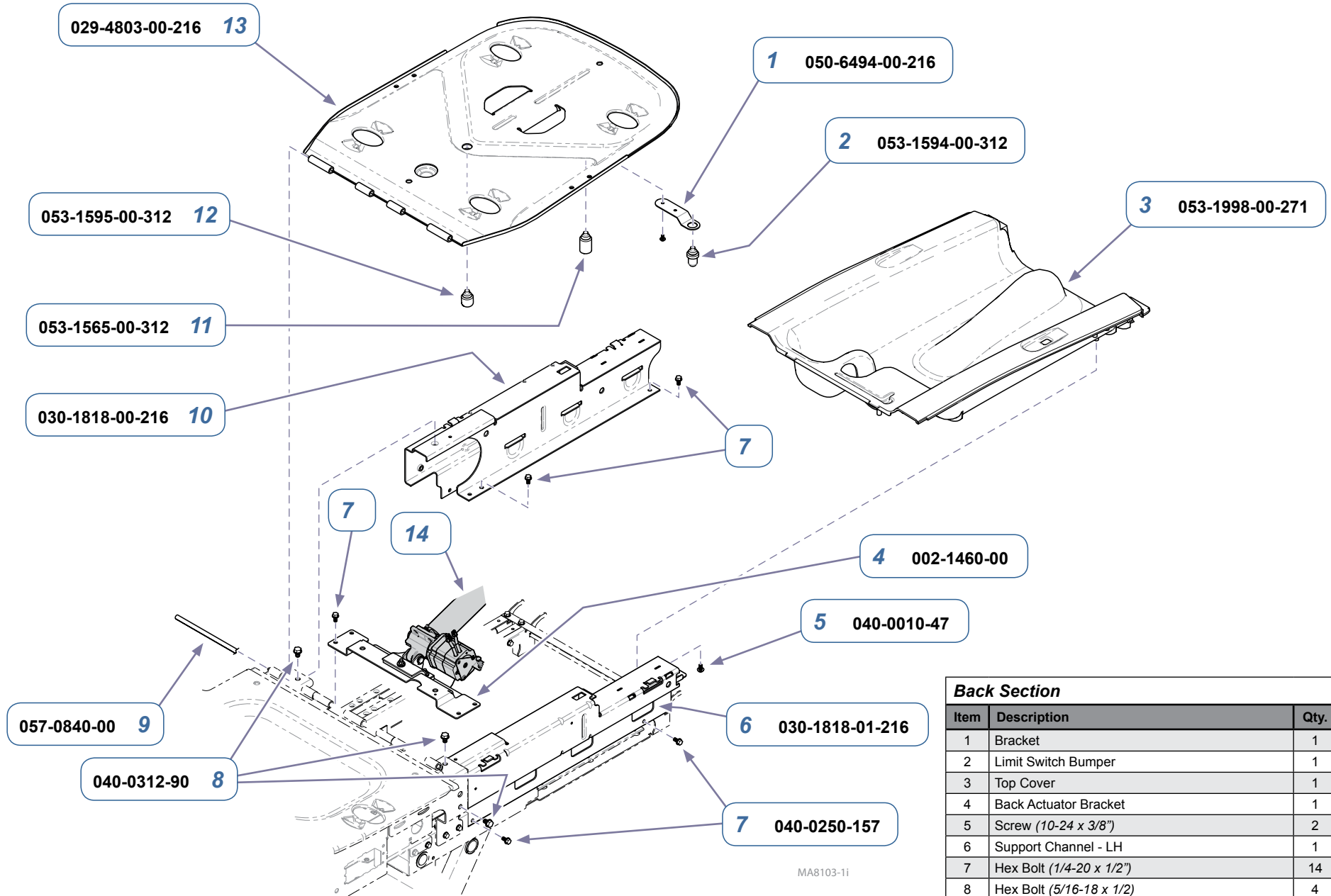

Back Section		
Item	Description	Qty.
1	Bracket	1
2	Limit Switch Bumper	1
3	Top Cover	1
4	Back Actuator Bracket	1
5	Screw (10-24 x 3/8")	2
6	Support Channel - LH	1
7	Hex Bolt (1/4-20 x 1/2")	14
8	Hex Bolt (5/16-18 x 1/2)	4
9	Hinge Rod	1
10	Support Channel - RH	1
11	Bumper	2
12	Bumper	1
13	Back Weldment	1
14	Refer to: "Back Actuator / Limit Switches"	Ref

Models:	625
Serial Numbers:	V1083262 thru Present

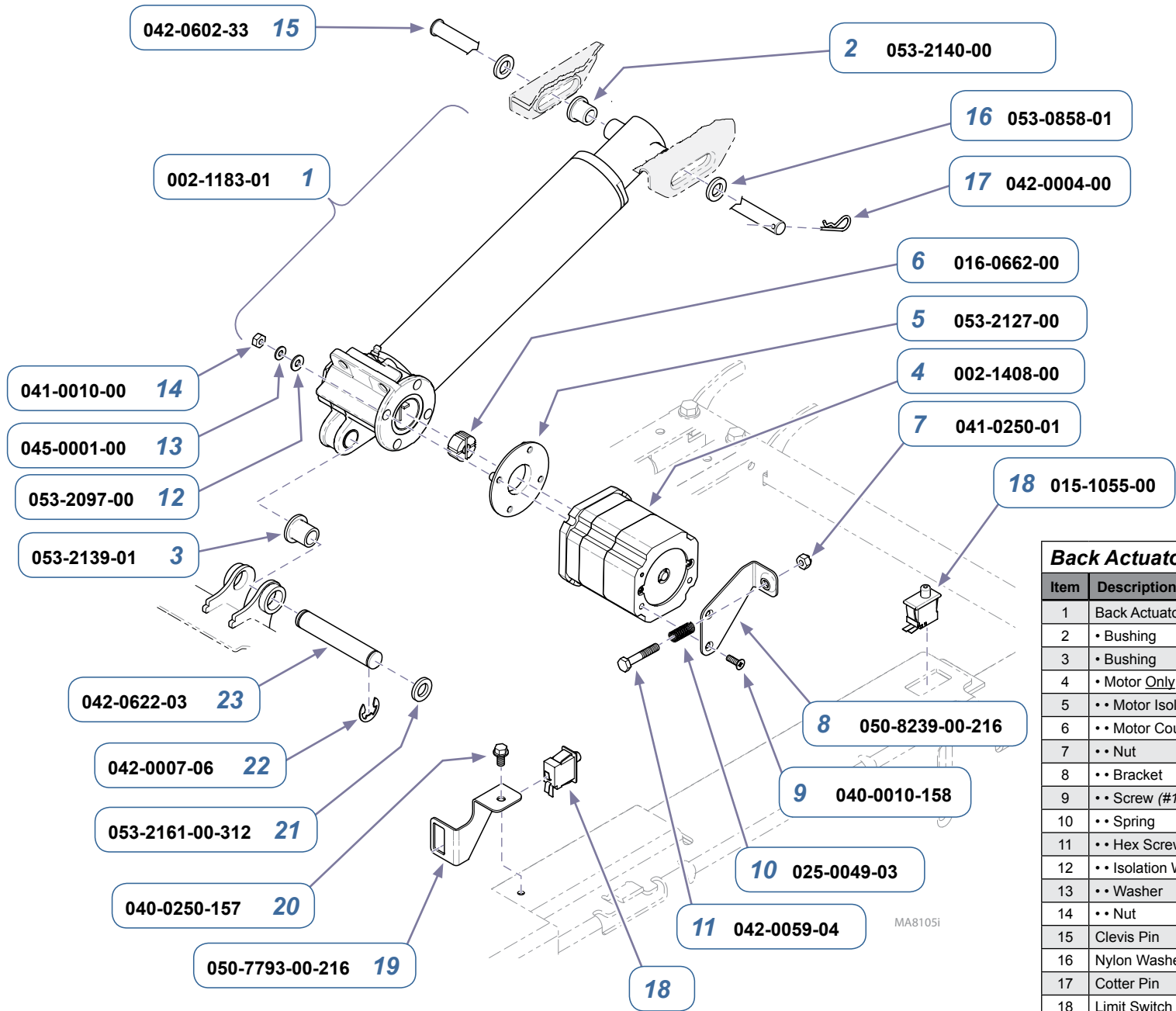

Back Actuator / Limit Switches		
Item	Description	Qty.
1	Back Actuator Assembly (incl. items 2 thru 4)	1
2	• Bushing	2
3	• Bushing	2
4	• Motor Only (includes items 5 thru 14)	1
5	•• Motor Isolator	1
6	•• Motor Coupler	1
7	•• Nut	1
8	•• Bracket	1
9	•• Screw (#10 x 32 x 1/4")	2
10	•• Spring	1
11	•• Hex Screw (1/4-20 x 1 1/2")	1
12	•• Isolation Washer	2
13	•• Washer	2
14	•• Nut	2
15	Clevis Pin	1
16	Nylon Washer	2
17	Cotter Pin	1
18	Limit Switch	2
19	Bracket	1
20	Hex Screw	1
21	Rubber Washer	2
22	E-ring	2
23	Clevis Pin	1

Models: 625
Serial Numbers: V2200 thru V1083261

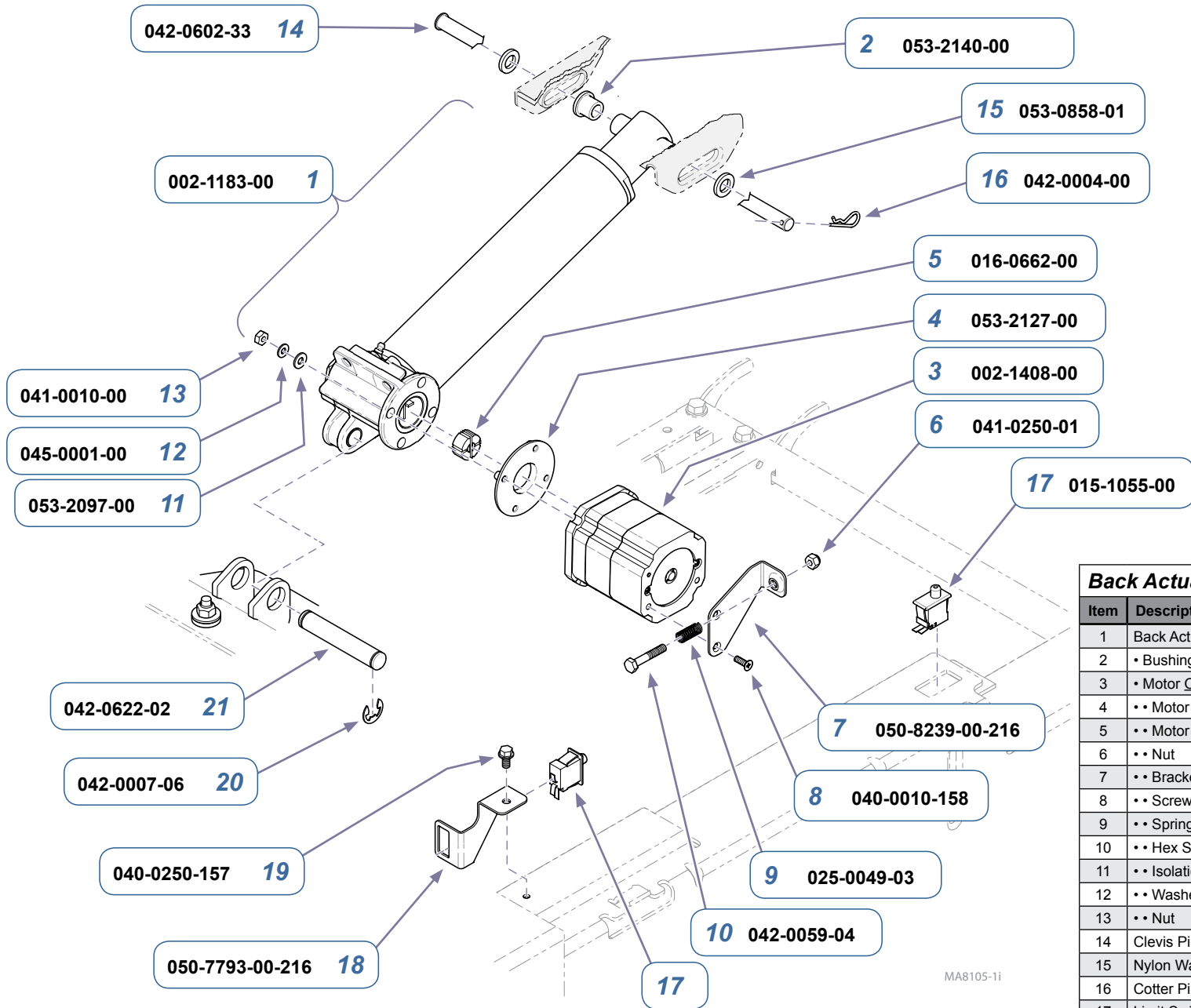

Back Actuator / Limit Switches

Item	Description	Qty.
1	Back Actuator Assembly (incl. items 2 & 3)	1
2	• Bushing	2
3	• Motor Only (includes items 4 thru 13)	1
4	•• Motor Isolator	1
5	•• Motor Coupler	1
6	•• Nut	1
7	•• Bracket	1
8	•• Screw (#10 x 32 x 1/4")	2
9	•• Spring	1
10	•• Hex Screw (1/4-20 x 1 1/2")	1
11	•• Isolation Washer	2
12	•• Washer	2
13	•• Nut	2
14	Clevis Pin	1
15	Nylon Washer	2
16	Cotter Pin	1
17	Limit Switch	2
18	Bracket	1
19	Hex Screw	1
20	E-ring	2
21	Clevis Pin	1

Models:	625
Serial Numbers:	V1083262 thru V1513012

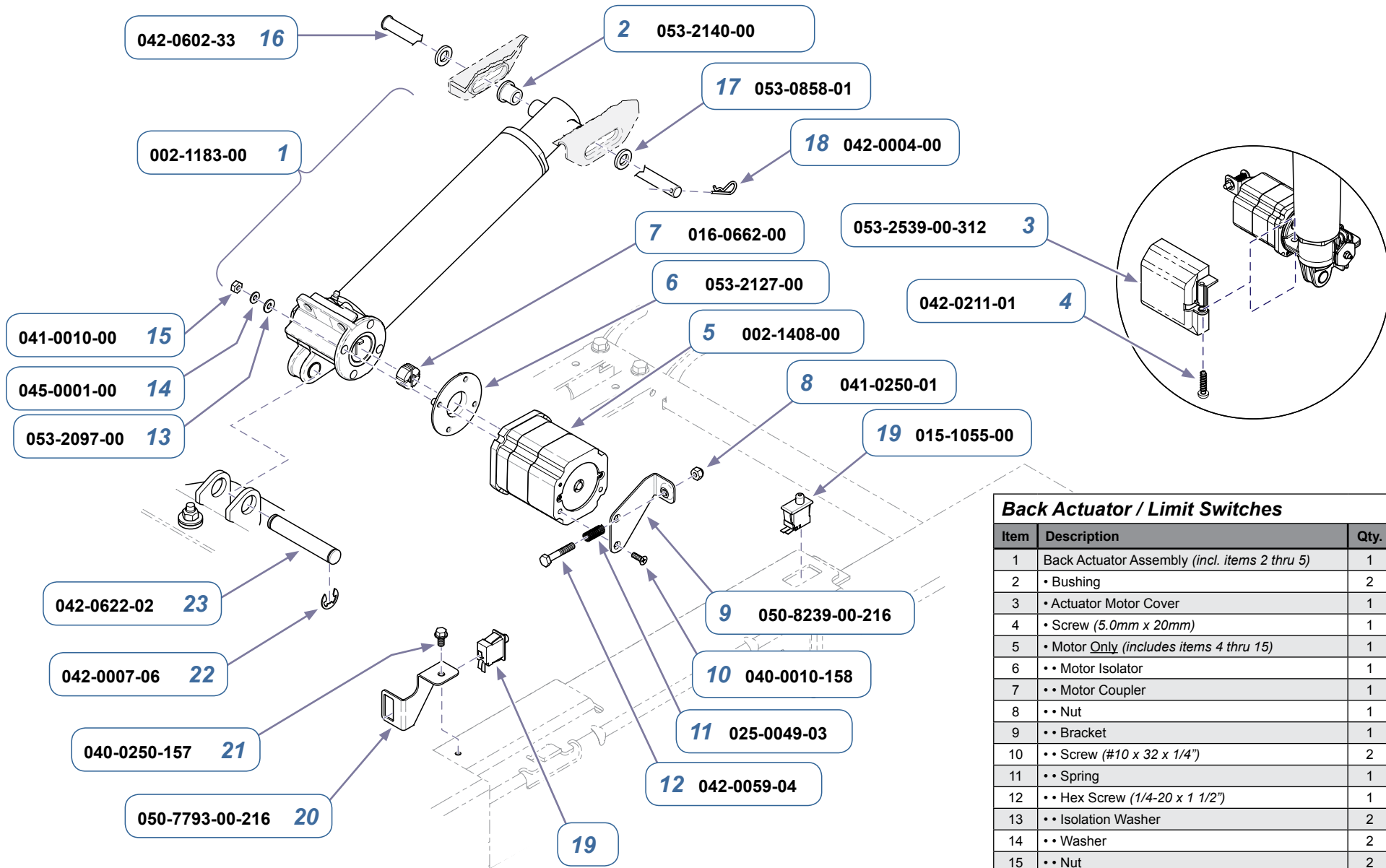

Back Actuator / Limit Switches		
Item	Description	Qty.
1	Back Actuator Assembly (incl. items 2 thru 5)	1
2	• Bushing	2
3	• Actuator Motor Cover	1
4	• Screw (5.0mm x 20mm)	1
5	• Motor Only (includes items 4 thru 15)	1
6	•• Motor Isolator	1
7	•• Motor Coupler	1
8	•• Nut	1
9	•• Bracket	1
10	•• Screw (#10 x 32 x 1/4")	2
11	•• Spring	1
12	•• Hex Screw (1/4-20 x 1 1/2")	1
13	•• Isolation Washer	2
14	•• Washer	2
15	•• Nut	2
16	Clevis Pin	1
17	Nylon Washer	2
18	Cotter Pin	1
19	Limit Switch	2
20	Bracket	1
21	Hex Screw	1
22	E-ring	2
23	Clevis Pin	1

Models:	625
Serial Numbers:	V1513013 thru Present

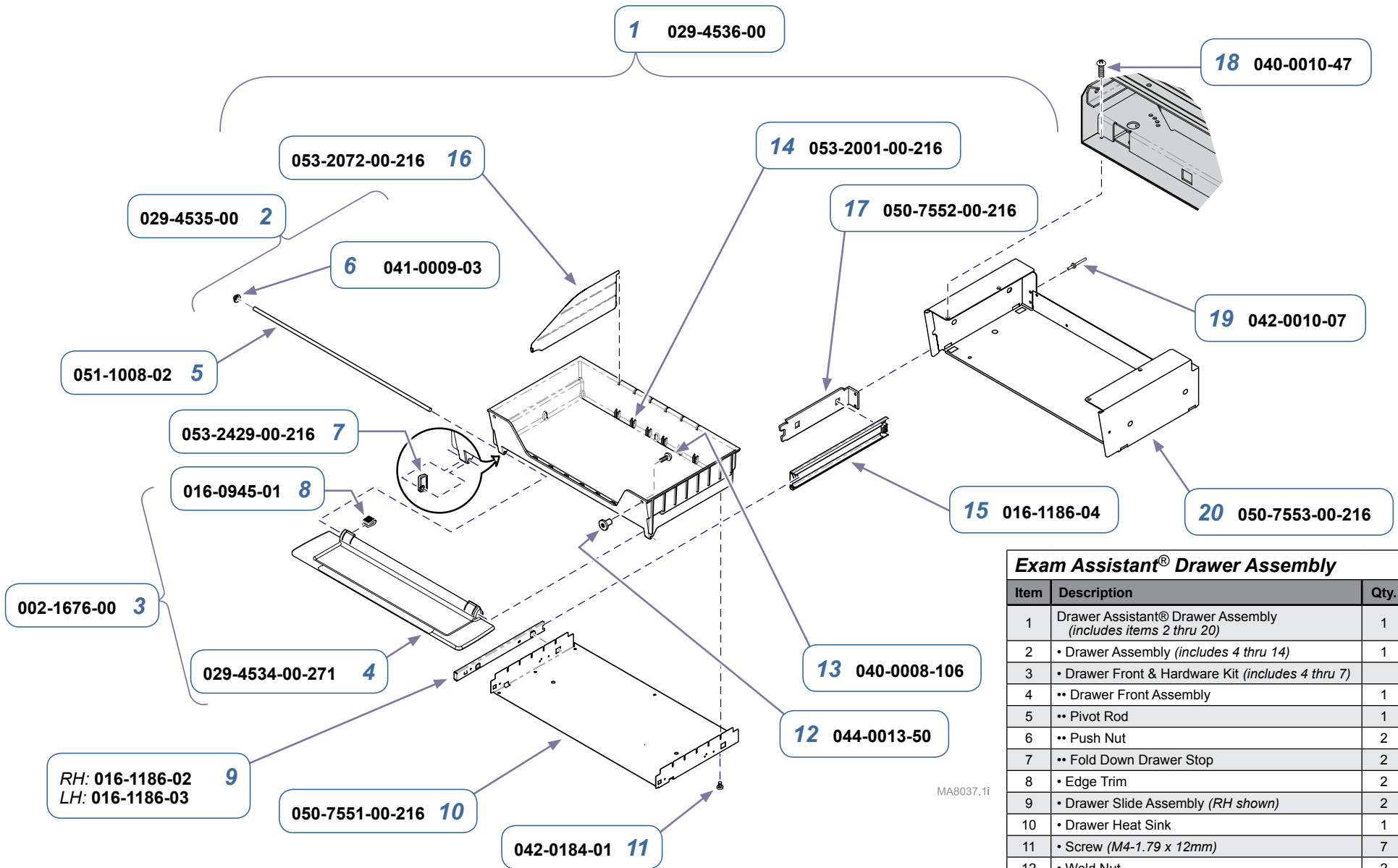

Exam Assistant® Drawer Assembly		
Item	Description	Qty.
1	Drawer Assistant® Drawer Assembly (includes items 2 thru 20)	1
2	• Drawer Assembly (includes 4 thru 14)	1
3	• Drawer Front & Hardware Kit (includes 4 thru 7)	1
4	•• Drawer Front Assembly	1
5	•• Pivot Rod	1
6	•• Push Nut	2
7	•• Fold Down Drawer Stop	2
8	• Edge Trim	2
9	• Drawer Slide Assembly (RH shown)	2
10	• Drawer Heat Sink	1
11	• Screw (M4-1.79 x 12mm)	7
12	• Weld Nut	2
13	• Screw (#8-32 x 1/4")	2
14	• Drawer	1
15	• Outer & Middle Slide Assembly	2
16	• Drawer Divider	2
17	• Side Bracket	2
18	• Screw	4
19	• Pop Rivet	4
20	• Drawer Housing	1

Models:	625
Serial Numbers:	V1307859 thru Present

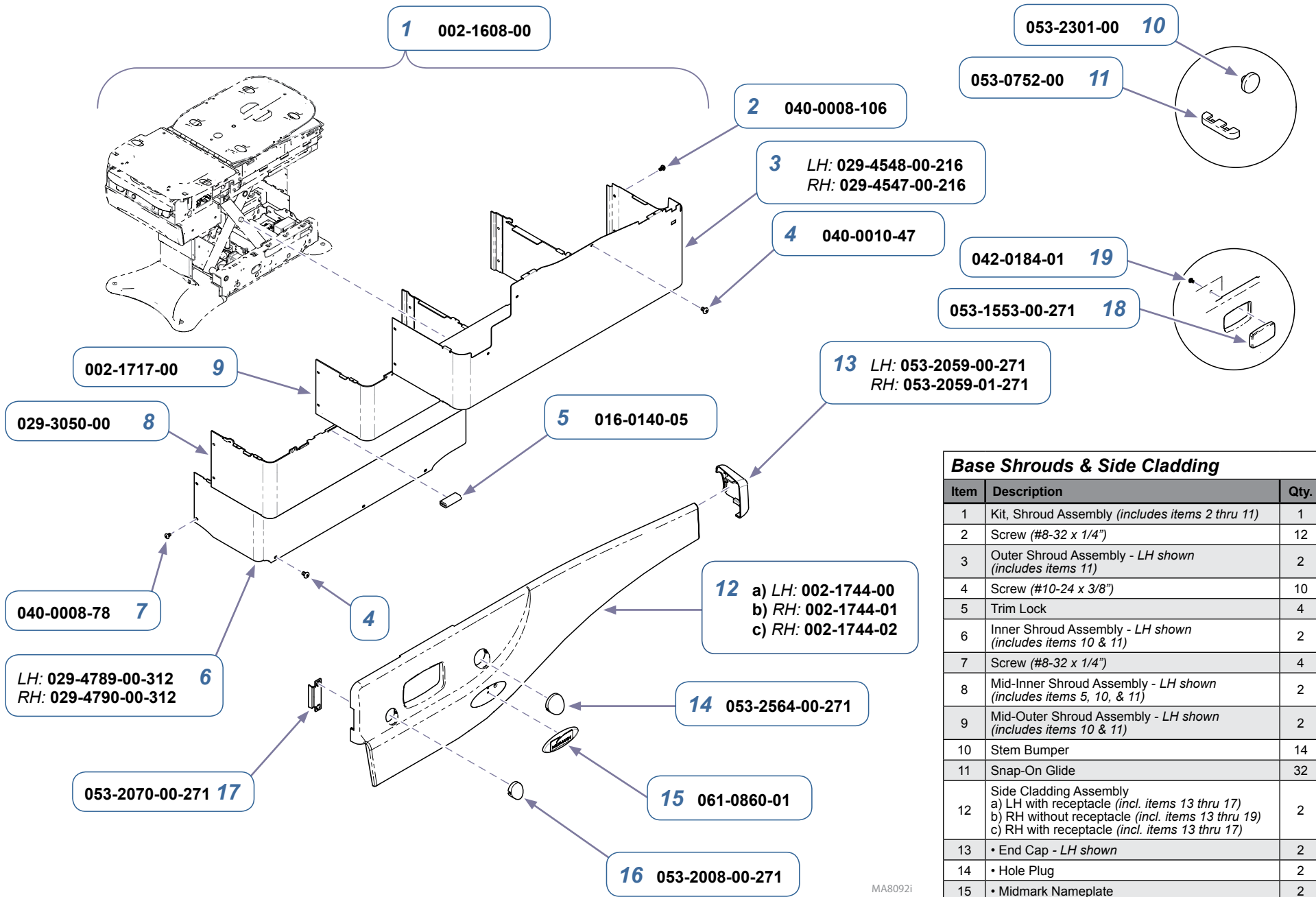

Base Shrouds & Side Cladding		
Item	Description	Qty.
1	Kit, Shroud Assembly (includes items 2 thru 11)	1
2	Screw (#8-32 x 1/4")	12
3	Outer Shroud Assembly - LH shown (includes items 11)	2
4	Screw (#10-24 x 3/8")	10
5	Trim Lock	4
6	Inner Shroud Assembly - LH shown (includes items 10 & 11)	2
7	Screw (#8-32 x 1/4")	4
8	Mid-Inner Shroud Assembly - LH shown (includes items 5, 10, & 11)	2
9	Mid-Outer Shroud Assembly - LH shown (includes items 10 & 11)	2
10	Stem Bumper	14
11	Snap-On Glide	32
12	Side Cladding Assembly a) LH with receptacle (incl. items 13 thru 17) b) RH without receptacle (incl. items 13 thru 19) c) RH with receptacle (incl. items 13 thru 17)	2
13	• End Cap - LH shown	2
14	• Hole Plug	2
15	• Midmark Nameplate	2
16	• Hole Plug	2
17	• Knee Crutch Access Cover	2
Items 18 & 19 apply only to models w/o receptacle		
18	• Receptacle Hole Cover	1
19	• Screw (M4 x 12)	2

Models:	625
Serial Numbers:	V2200 thru V1077078

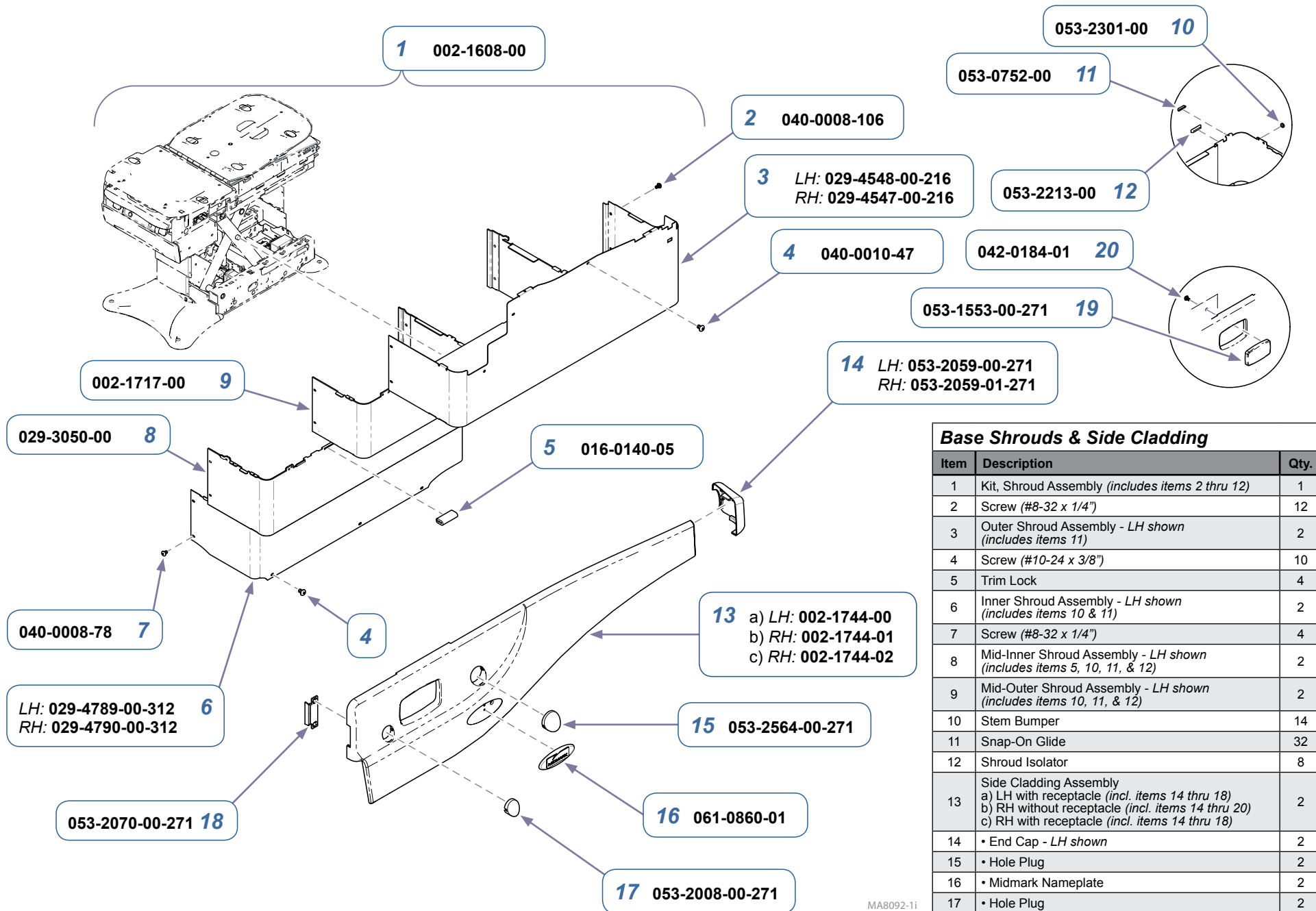

Base Shrouds & Side Cladding		
Item	Description	Qty.
1	Kit, Shroud Assembly (includes items 2 thru 12)	1
2	Screw (#8-32 x 1/4")	12
3	Outer Shroud Assembly - LH shown (includes items 11)	2
4	Screw (#10-24 x 3/8")	10
5	Trim Lock	4
6	Inner Shroud Assembly - LH shown (includes items 10 & 11)	2
7	Screw (#8-32 x 1/4")	4
8	Mid-Inner Shroud Assembly - LH shown (includes items 5, 10, 11, & 12)	2
9	Mid-Outer Shroud Assembly - LH shown (includes items 10, 11, & 12)	2
10	Stem Bumper	14
11	Snap-On Glide	32
12	Shroud Isolator	8
13	Side Cladding Assembly a) LH with receptacle (incl. items 14 thru 18) b) RH without receptacle (incl. items 14 thru 20) c) RH with receptacle (incl. items 14 thru 18)	2
14	• End Cap - LH shown	2
15	• Hole Plug	2
16	• Midmark Nameplate	2
17	• Hole Plug	2
18	• Knee Crutch Access Cover	2
Items 19 & 20 apply only to models w/o receptacle		
19	• Receptacle Hole Cover	1
20	• Screw (M4 x 12)	2

Models:	625
Serial Numbers:	V1077079 thru V1089389

MA8092-11

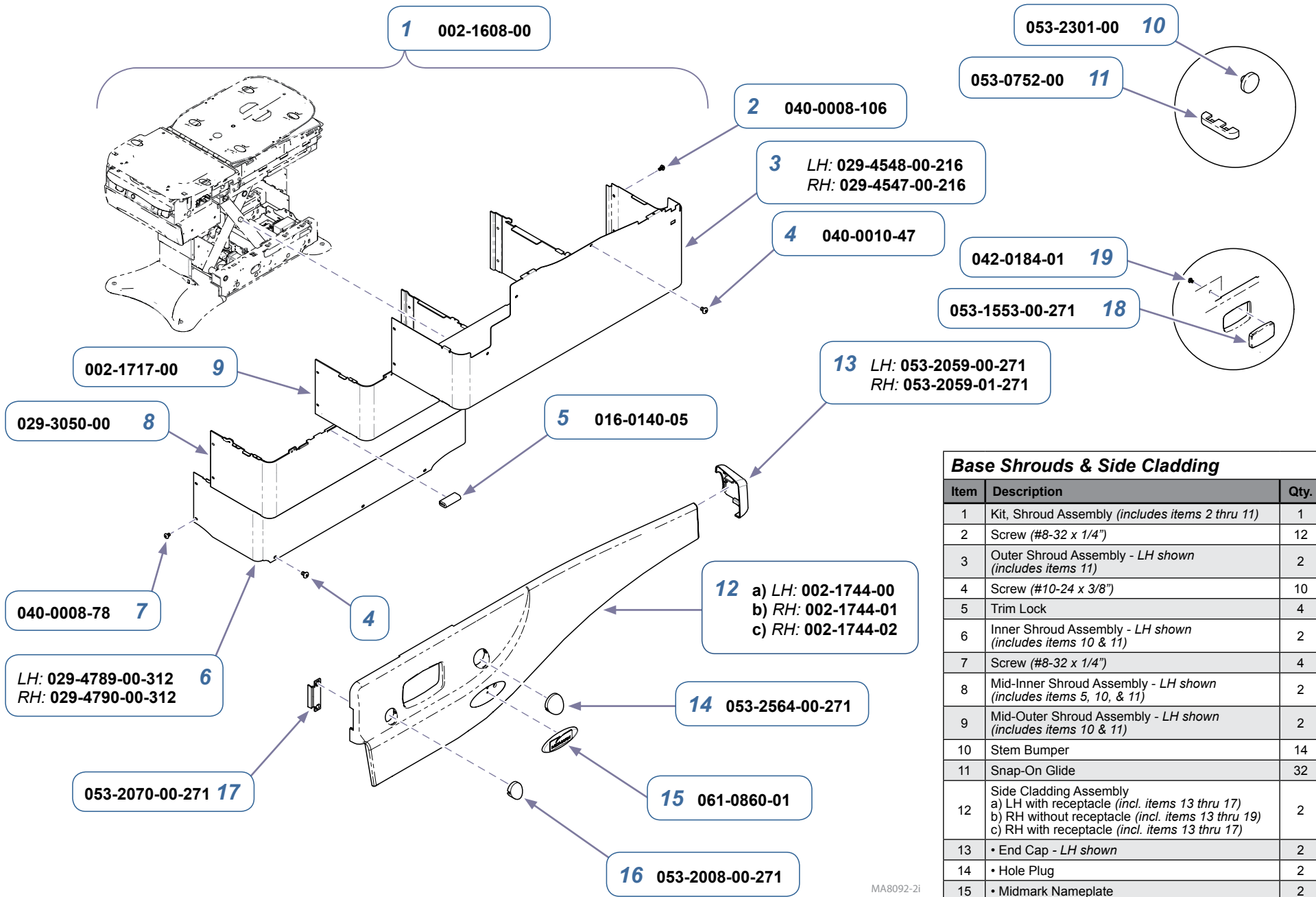

Base Shrouds & Side Cladding		
Item	Description	Qty.
1	Kit, Shroud Assembly (includes items 2 thru 11)	1
2	Screw (#8-32 x 1/4")	12
3	Outer Shroud Assembly - LH shown (includes items 11)	2
4	Screw (#10-24 x 3/8")	10
5	Trim Lock	4
6	Inner Shroud Assembly - LH shown (includes items 10 & 11)	2
7	Screw (#8-32 x 1/4")	4
8	Mid-Inner Shroud Assembly - LH shown (includes items 5, 10, & 11)	2
9	Mid-Outer Shroud Assembly - LH shown (includes items 10 & 11)	2
10	Stem Bumper	14
11	Snap-On Glide	32
12	Side Cladding Assembly a) LH with receptacle (incl. items 13 thru 17) b) RH without receptacle (incl. items 13 thru 19) c) RH with receptacle (incl. items 13 thru 17)	2
13	• End Cap - LH shown	2
14	• Hole Plug	2
15	• Midmark Nameplate	2
16	• Hole Plug	2
17	• Knee Crutch Access Cover	2
Items 18 & 19 apply only to models w/o receptacle		
18	• Receptacle Hole Cover	1
19	• Screw (M4 x 12)	2

Models:	625
Serial Numbers:	V1089390 thru V1099004

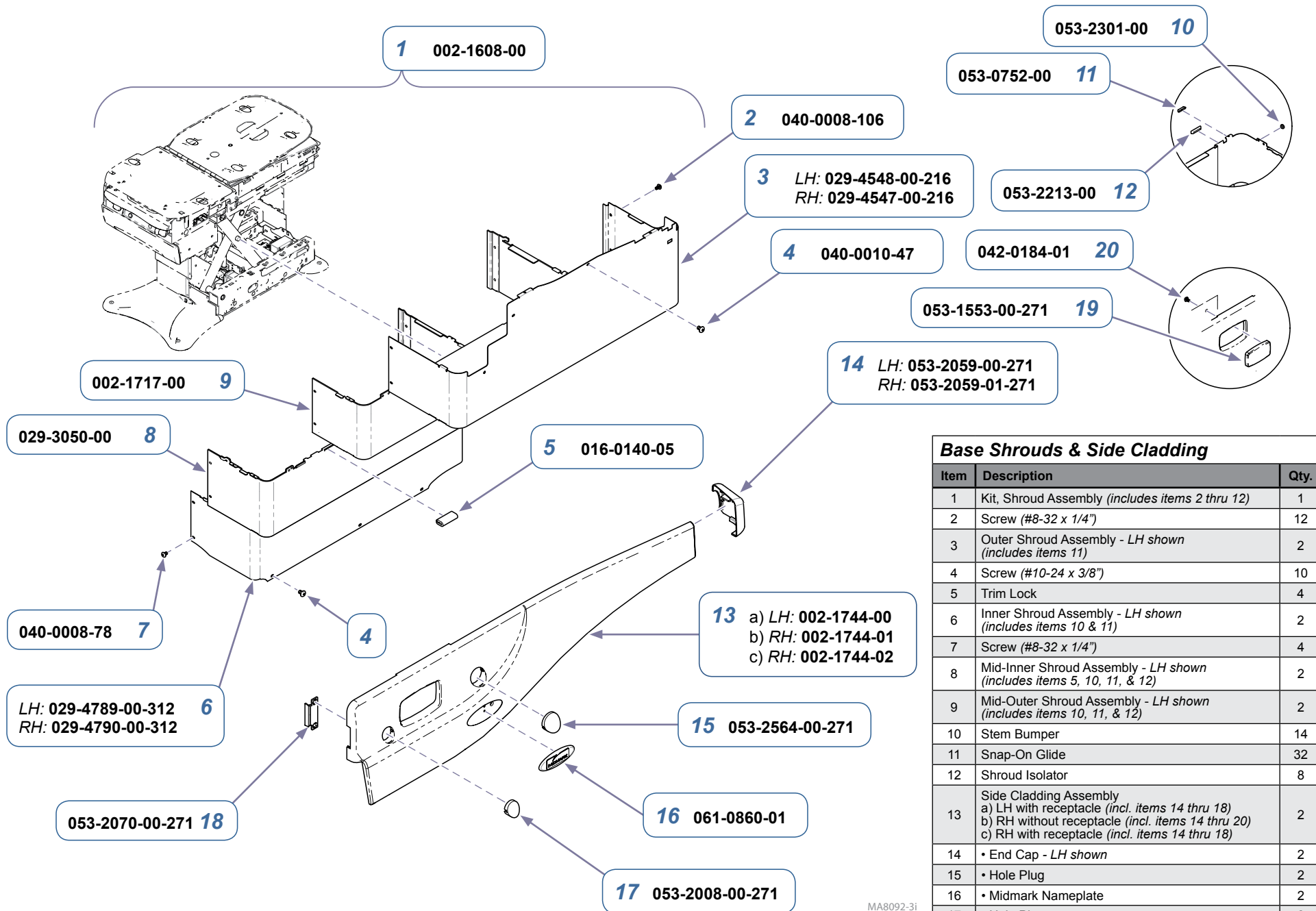

Base Shrouds & Side Cladding		
Item	Description	Qty.
1	Kit, Shroud Assembly (includes items 2 thru 12)	1
2	Screw (#8-32 x 1/4")	12
3	Outer Shroud Assembly - LH shown (includes items 11)	2
4	Screw (#10-24 x 3/8")	10
5	Trim Lock	4
6	Inner Shroud Assembly - LH shown (includes items 10 & 11)	2
7	Screw (#8-32 x 1/4")	4
8	Mid-Inner Shroud Assembly - LH shown (includes items 5, 10, 11, & 12)	2
9	Mid-Outer Shroud Assembly - LH shown (includes items 10, 11, & 12)	2
10	Stem Bumper	14
11	Snap-On Glide	32
12	Shroud Isolator	8
13	Side Cladding Assembly a) LH with receptacle (incl. items 14 thru 18) b) RH without receptacle (incl. items 14 thru 20) c) RH with receptacle (incl. items 14 thru 18)	2
14	• End Cap - LH shown	2
15	• Hole Plug	2
16	• Midmark Nameplate	2
17	• Hole Plug	2
18	• Knee Crutch Access Cover	2
Items 19 & 20 apply only to models w/o receptacle		
19	• Receptacle Hole Cover	1
20	• Screw (M4 x 12)	2

Models:	625
Serial Numbers:	V1099005 - V1563949

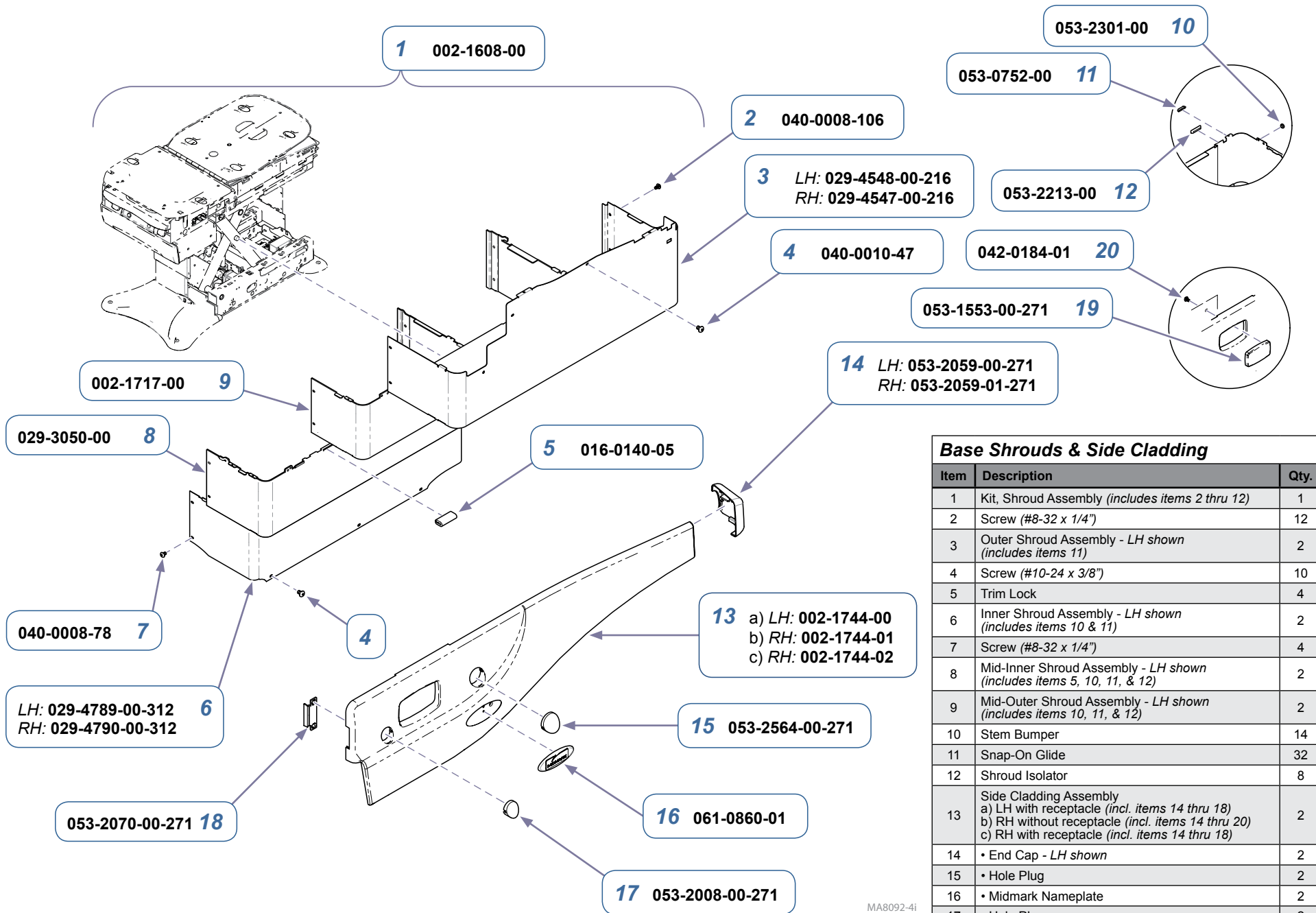

Base Shrouds & Side Cladding		
Item	Description	Qty.
1	Kit, Shroud Assembly (includes items 2 thru 12)	1
2	Screw (#8-32 x 1/4")	12
3	Outer Shroud Assembly - LH shown (includes items 11)	2
4	Screw (#10-24 x 3/8")	10
5	Trim Lock	4
6	Inner Shroud Assembly - LH shown (includes items 10 & 11)	2
7	Screw (#8-32 x 1/4")	4
8	Mid-Inner Shroud Assembly - LH shown (includes items 5, 10, 11, & 12)	2
9	Mid-Outer Shroud Assembly - LH shown (includes items 10, 11, & 12)	2
10	Stem Bumper	14
11	Snap-On Glide	32
12	Shroud Isolator	8
13	Side Cladding Assembly a) LH with receptacle (incl. items 14 thru 18) b) RH without receptacle (incl. items 14 thru 20) c) RH with receptacle (incl. items 14 thru 18)	2
14	• End Cap - LH shown	2
15	• Hole Plug	2
16	• Midmark Nameplate	2
17	• Hole Plug	2
18	• Knee Crutch Access Cover	2
Items 19 & 20 apply only to models w/o receptacle		
19	• Receptacle Hole Cover	1
20	• Screw (M4 x 12)	2

Models:	625
Serial Numbers:	V1563950 - Present

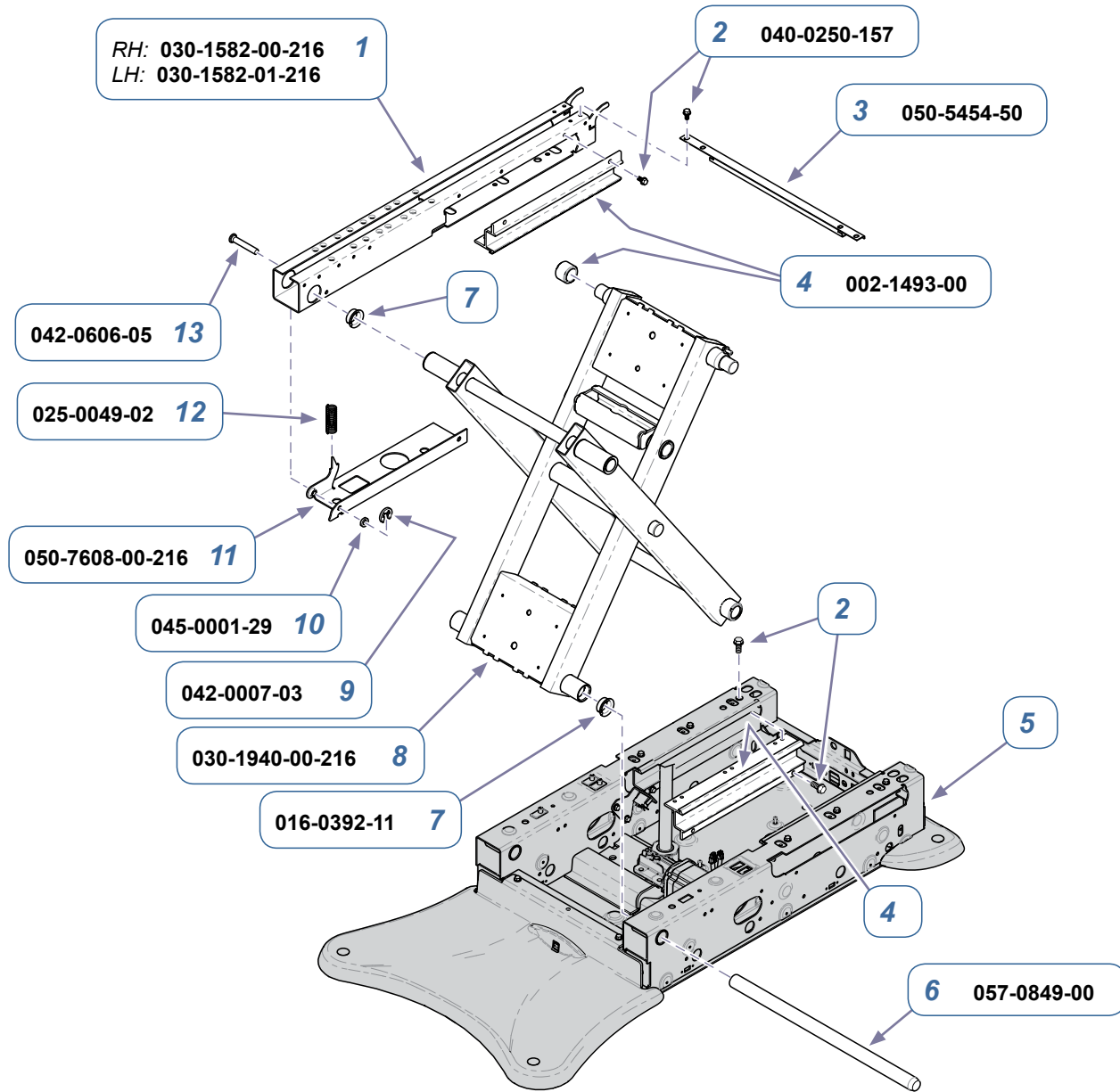

MA8099i

Base Scissor / Slide Mechanism		
Item	Description	Qty.
1	Scissor Channel Weldment (<i>RH shown</i>)	2
2	Flat Head Screw (1/4-20 x 1/2")	4
3	Top Cover Support Channel	1
4	Kit, Scissor Rollers	1
5	Refer to: "Base Components"	Ref
6	Pivot Shaft	1
7	Flange Bearing	4
8	Scissor Arm Weldment	1
9	E-clip	1
10	Washer	1
11	Auto Return ("Home") Switch Strike	1
12	Spring	1
13	Clevis Pin	1

Models:	625
Serial Numbers:	V2200 thru V1158421

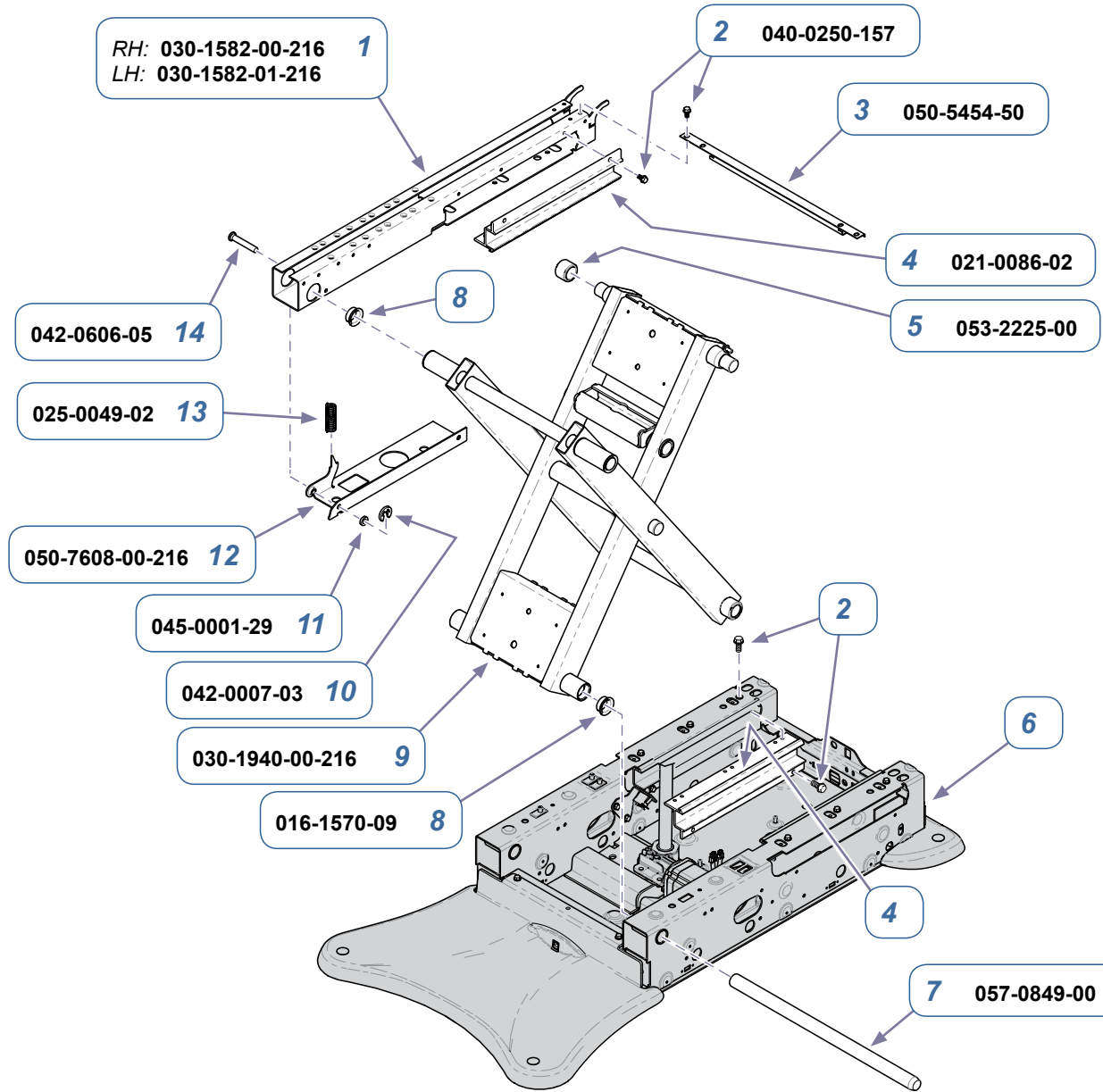

MA8384I

Base Scissor / Slide Mechanism		
Item	Description	Qty.
1	Scissor Channel Weldment (RH shown)	2
2	Flat Head Screw (1/4-20 x 1/2")	4
3	Top Cover Support Channel	1
4	Extrusion Slide	2
5	Bearing Guide	4
6	Refer to: "Base Components"	Ref
7	Pivot Shaft	1
8	Flange Bearing	4
9	Scissor Arm Weldment	1
10	E-clip	1
11	Washer	1
12	Auto Return ("Home") Switch Strike	1
13	Spring	1
14	Clevis Pin	1

Models:	625
Serial Numbers:	V1158422 thru Present

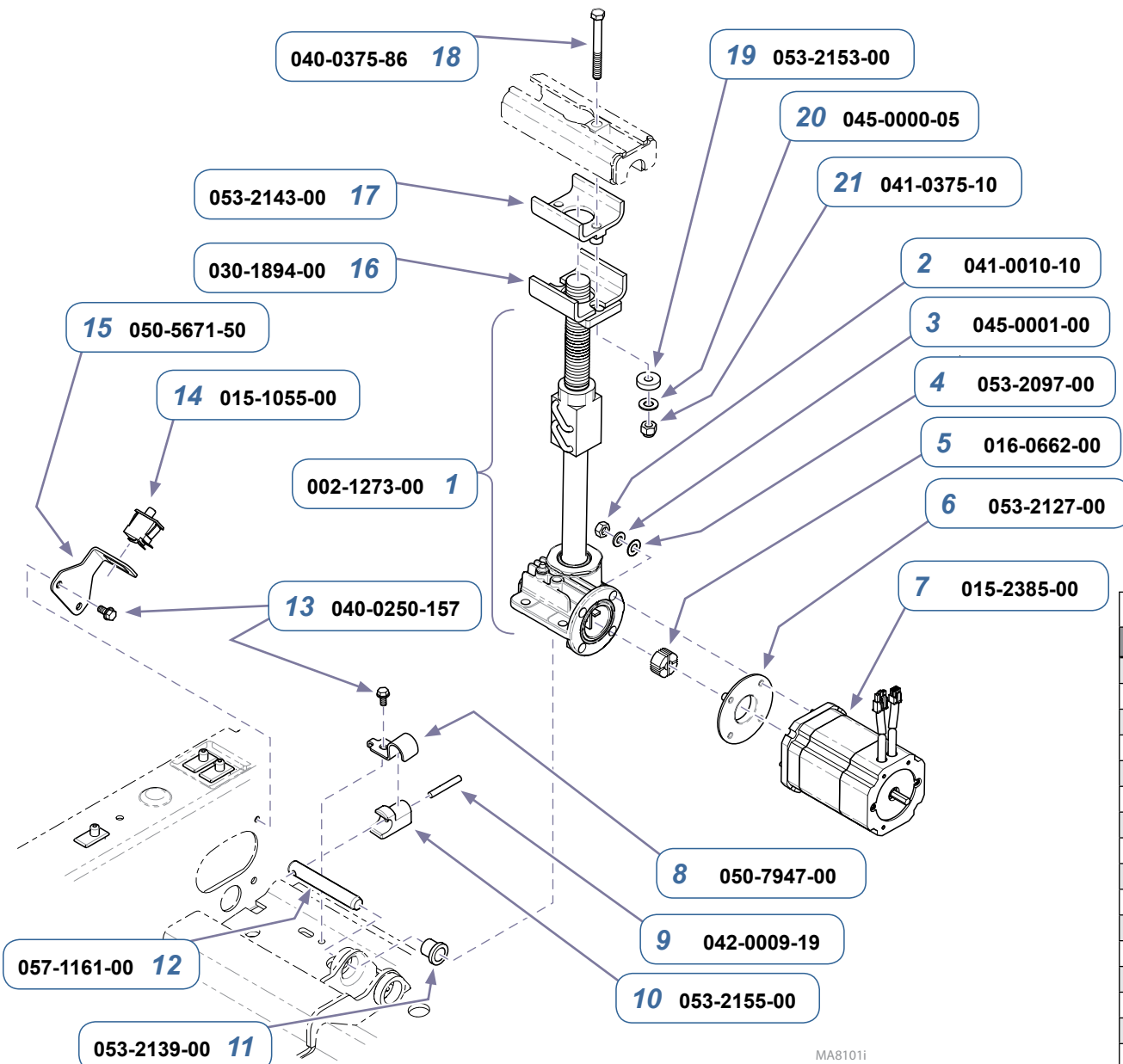

Base Actuator / Limit Switches

Item	Description	Qty.
1	Base Actuator Kit (includes items 2 thru 7)	1
2	• Nut	2
3	• Shim Washer	2
4	• Isolation Washer	2
5	• Motor Coupler	1
6	• Motor Isolator	1
7	• Motor Assembly	1
8	Isolator Clamp	1
9	Groove Pin	1
10	Actuator Pin Isolator	1
11	Bushing	2
12	Base Actuator Pin	1
13	Hex Bolt (1/4-20 x 1/2")	3
14	Limit Switch	4
15	Switch Bracket	1
16	Cradle Weldment	1
17	Pivot Block Isolator	1
18	Hex Screw (3/8-16 x 3 1/2")	2
19	Washer	2
20	Washer	2
21	Nut	2

Models:	625
Serial Numbers:	V2200 thru V968527

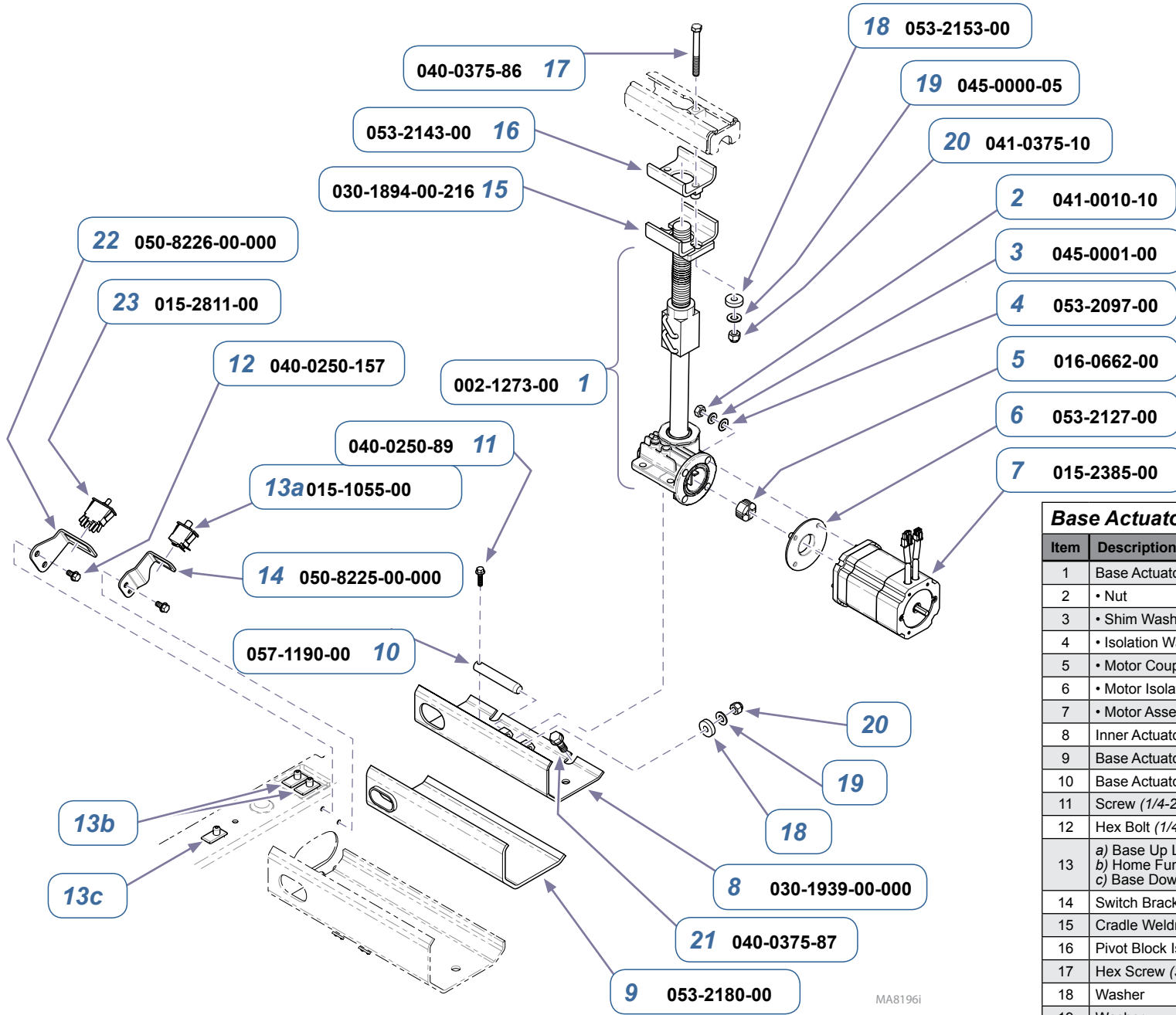

Base Actuator / Limit Switches		
Item	Description	Qty.
1	Base Actuator Kit (includes items 2 thru 7)	1
2	• Nut	2
3	• Shim Washer	2
4	• Isolation Washer	2
5	• Motor Coupler	1
6	• Motor Isolator	1
7	• Motor Assembly	1
8	Inner Actuator Mount	1
9	Base Actuator Isolator	1
10	Base Actuator Pin	1
11	Screw (1/4-20 x 1")	2
12	Hex Bolt (1/4-20 x 1/2")	4
13	a) Base Up Limit Switch b) Home Function Limit Switches c) Base Down Limit Switch	4
14	Switch Bracket	1
15	Cradle Weldment	1
16	Pivot Block Isolator	1
17	Hex Screw (3/8-16 x 3 1/2")	2
18	Washer	4
19	Washer	4
20	Nut	4
21	Hex Washer Head Screw (3/8-16 x 1 1/8")	2
22	Switch Bracket	1
23	Over Travel Limit Switch	1

Models: 625
Serial Numbers: V968528 thru present

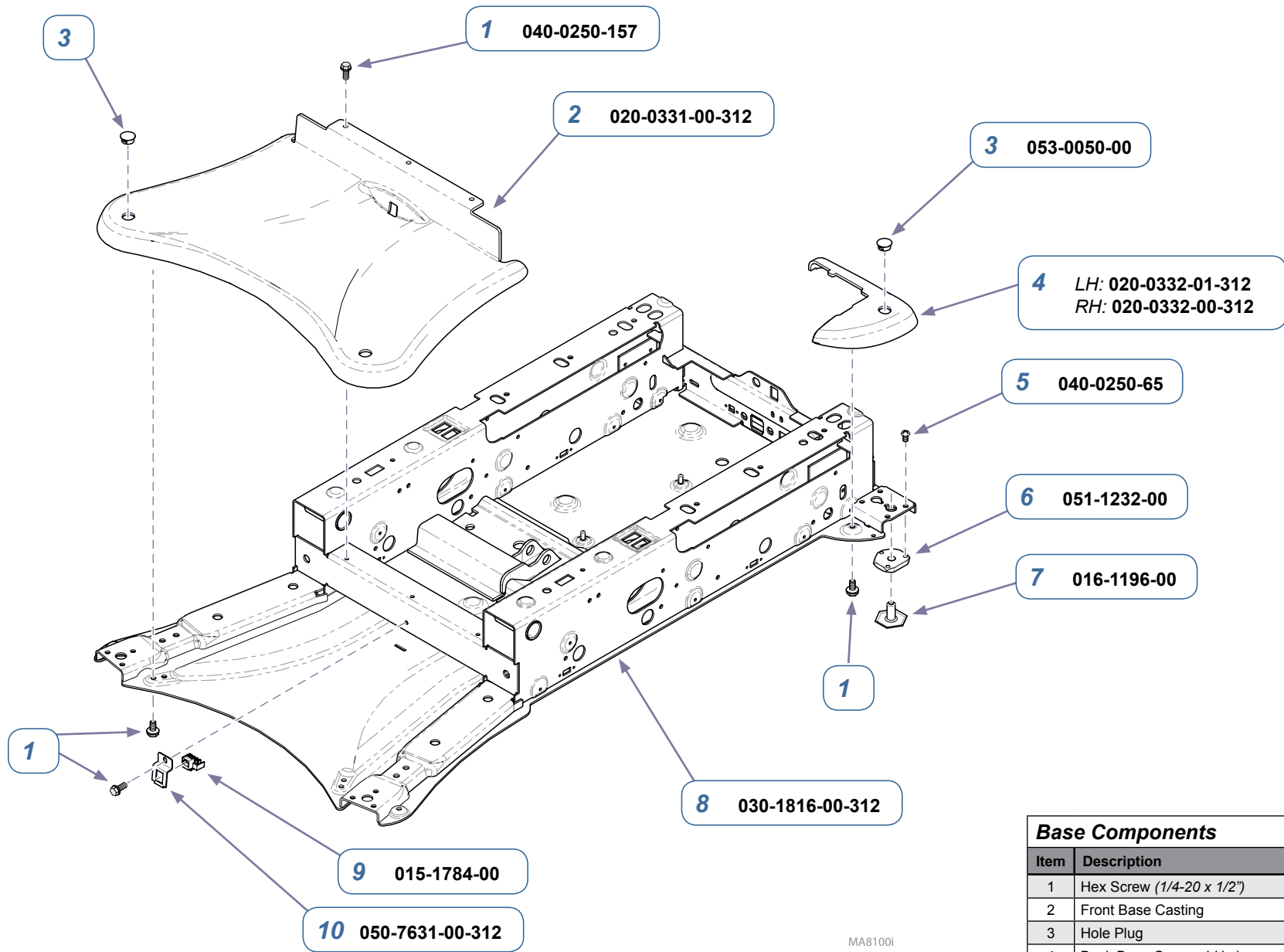

MA8100i

Base Components		
Item	Description	Qty.
1	Hex Screw (1/4-20 x 1/2")	11
2	Front Base Casting	1
3	Hole Plug	4
4	Back Base Cover - LH shown	2
5	Screw (1/4-20 x 1/2")	6
6	Leveling Foot Mount	2
7	Leveling Foot	2
8	Base Weldment	1
9	Hand / Foot Control Inlet	2
10	Bracket	1

Models: 625 (-001 /-003 /-005 /-006)

Serial Numbers: V2200 thru V968527

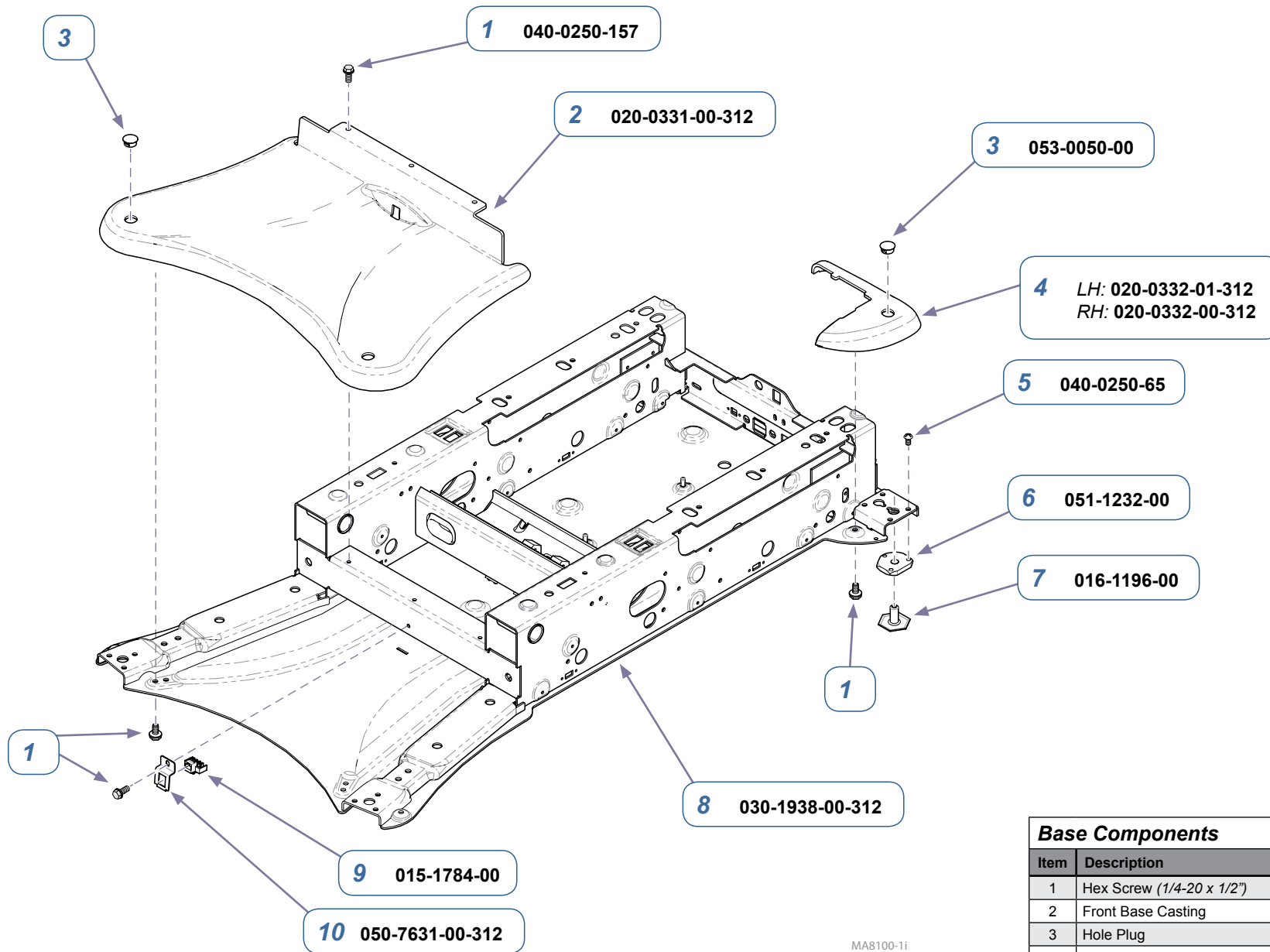

Base Components		
Item	Description	Qty.
1	Hex Screw (1/4-20 x 1/2")	11
2	Front Base Casting	1
3	Hole Plug	4
4	Back Base Cover - LH shown	2
5	Screw (1/4-20 x 1/2")	6
6	Leveling Foot Mount	2
7	Leveling Foot	2
8	Base Weldment	1
9	Hand / Foot Control Inlet	2
10	Bracket	1

Models: 625 (-001 /-003 /-005 /-006)

Serial Numbers: V968528 thru V1182355

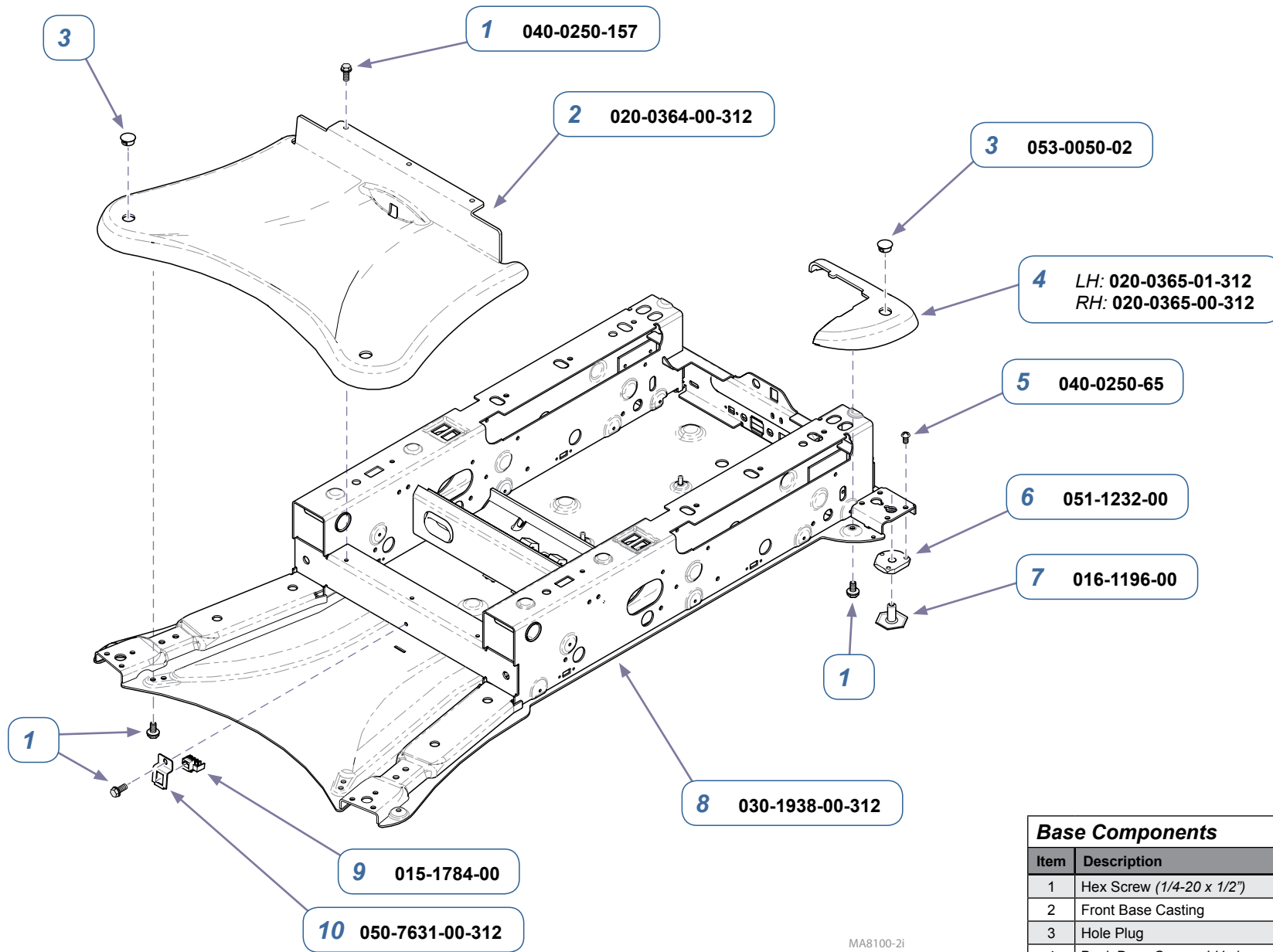

Base Components		
Item	Description	Qty.
1	Hex Screw (1/4-20 x 1/2")	11
2	Front Base Casting	1
3	Hole Plug	4
4	Back Base Cover - LH shown	2
5	Screw (1/4-20 x 1/2")	6
6	Leveling Foot Mount	2
7	Leveling Foot	2
8	Base Weldment	1
9	Hand / Foot Control Inlet	2
10	Bracket	1

Models: 625 (-001 /-003 /-005 /-006)

Serial Numbers: V1182356 thru Present

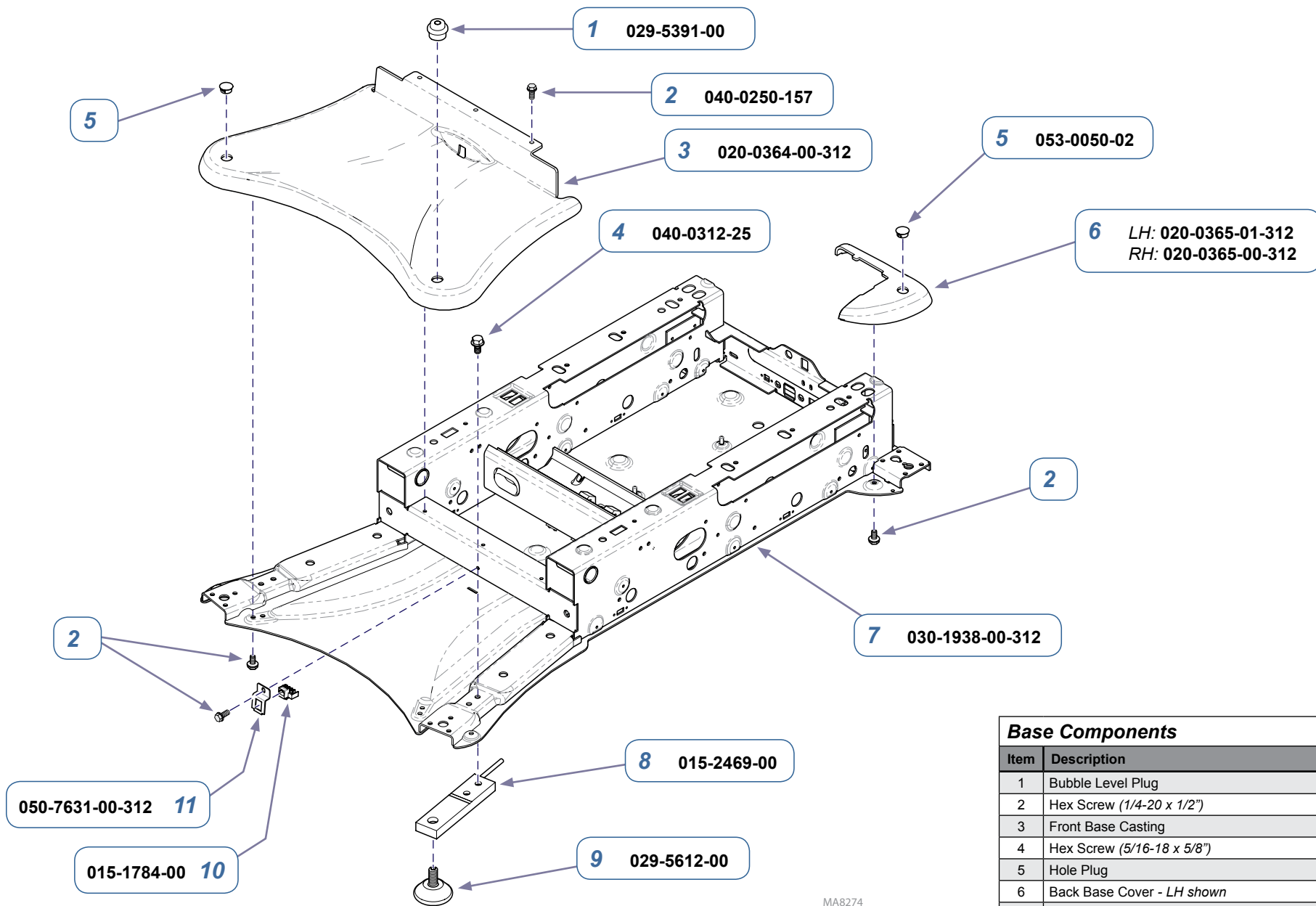

MA8274

Models:	625-004
Serial Numbers:	<i>all</i>

Base Components		
Item	Description	Qty.
1	Bubble Level Plug	1
2	Hex Screw (1/4-20 x 1/2")	11
3	Front Base Casting	1
4	Hex Screw (5/16-18 x 5/8")	8
5	Hole Plug	4
6	Back Base Cover - LH shown	2
7	Base Weldment	1
8	Load Cell	4
9	Leveling Feet Set (includes four leveling feet)	1
10	Hand / Foot Control Inlet	2
11	Bracket	1

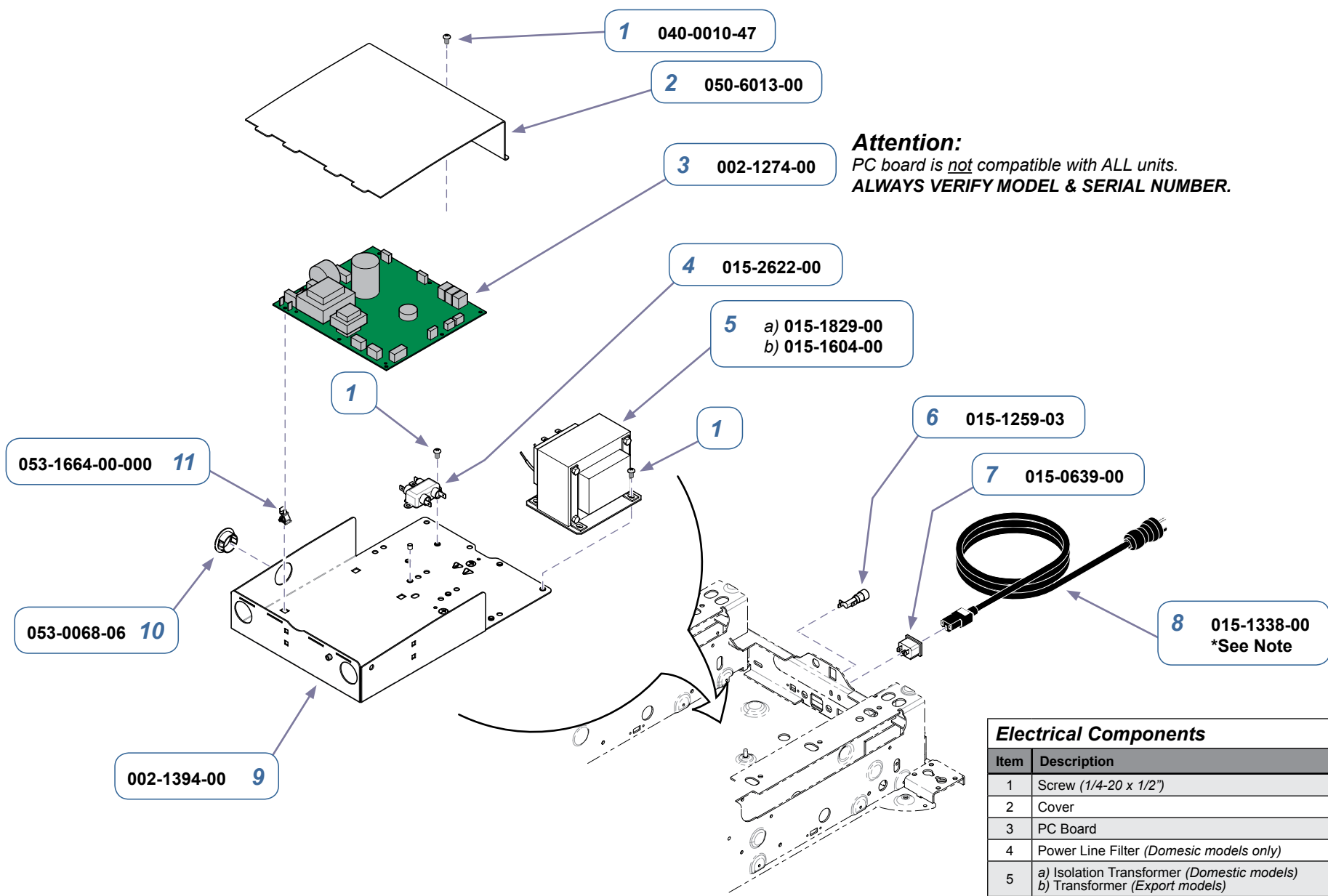

Attention:
 PC board is *not* compatible with ALL units.
ALWAYS VERIFY MODEL & SERIAL NUMBER.

Electrical Components		
Item	Description	Qty.
1	Screw (1/4-20 x 1/2")	8
2	Cover	1
3	PC Board	1
4	Power Line Filter (Domestic models only)	1
5	a) Isolation Transformer (Domestic models) b) Transformer (Export models)	1
6	Fuse Holder	2
7	Power Cord Inlet	1
8	Power Cord (N. American, 120V, 8 ft) *Note: Export models require accessory: 9A152 International Cordsets.	1
9	Housing (includes nutserts)	1
10	Snap Bushing	3
11	Standoff	6

Models: 625 (-001 /-003)

Serial Numbers: V2200 thru V968527

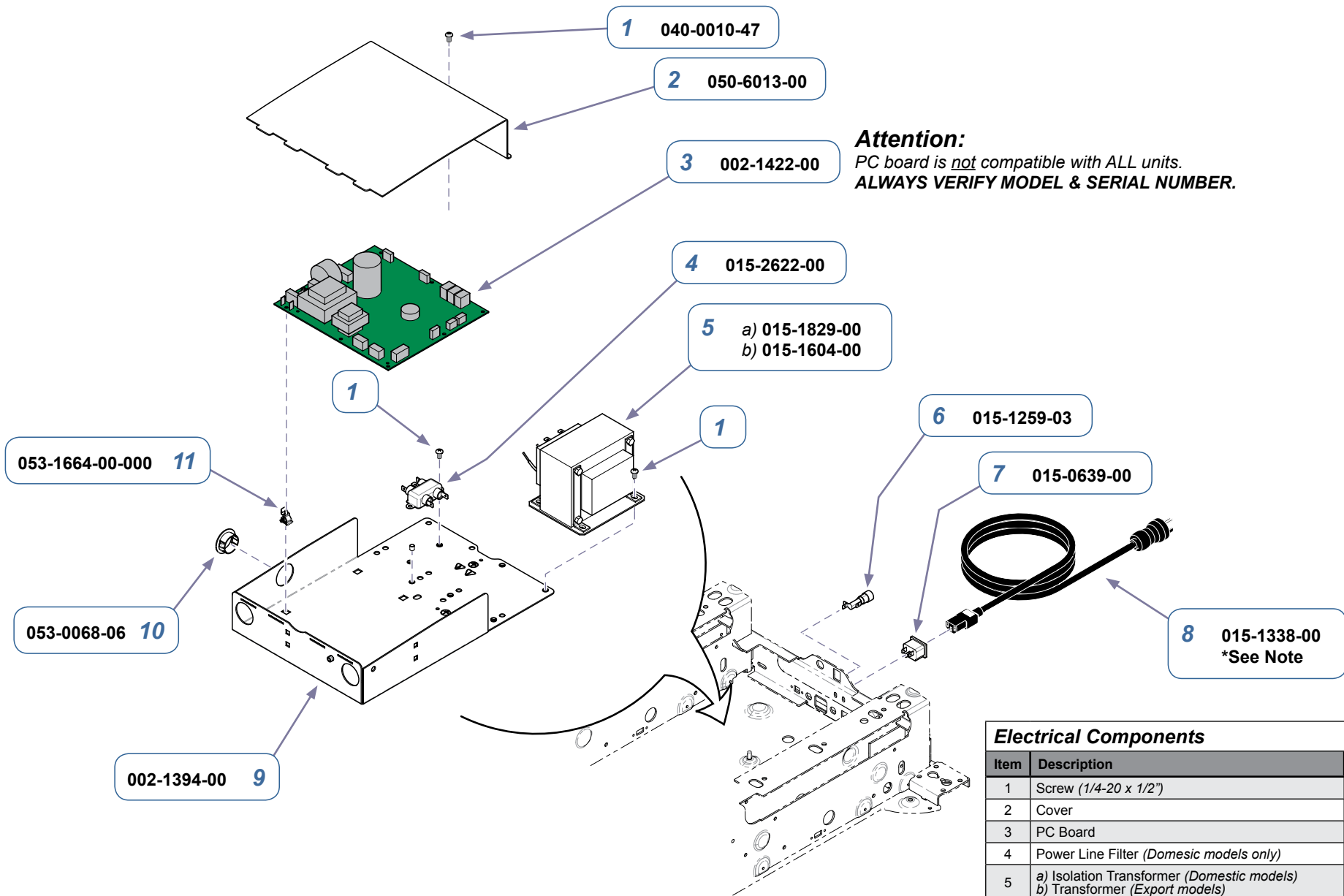

Electrical Components		
Item	Description	Qty.
1	Screw (1/4-20 x 1/2")	8
2	Cover	1
3	PC Board	1
4	Power Line Filter (Domestic models only)	1
5	a) Isolation Transformer (Domestic models) b) Transformer (Export models)	1
6	Fuse Holder	2
7	Power Cord Inlet	1
8	Power Cord (N. American, 120V, 8 ft) *Note: Export models require accessory: 9A152 International Cordsets.	1
9	Housing (includes nutserts)	1
10	Snap Bushing	3
11	Standoff	6

Models: 625 (-001 /-003)

Serial Numbers: V968528 thru V1266165

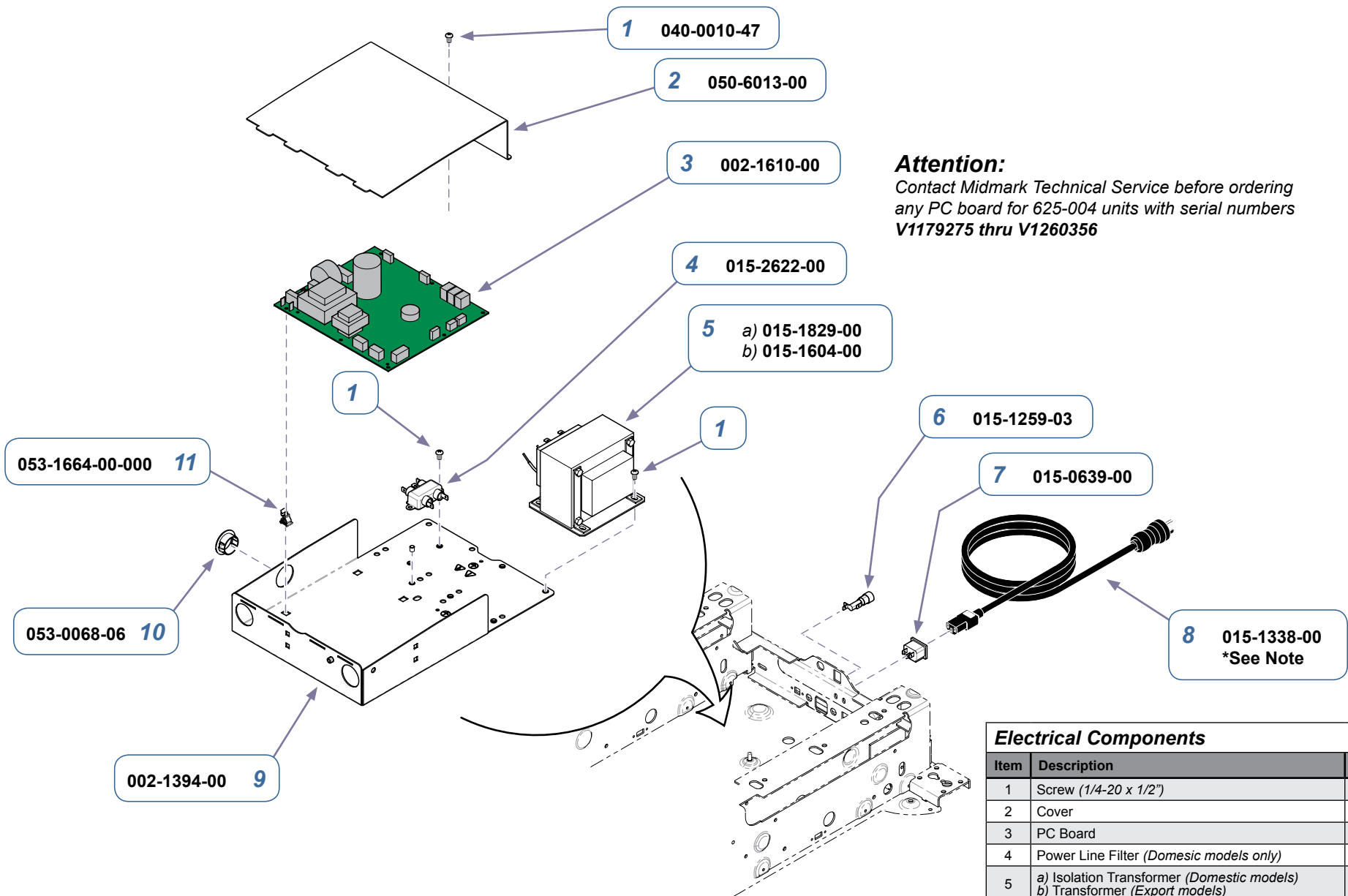

Attention:

Contact Midmark Technical Service before ordering any PC board for 625-004 units with serial numbers V1179275 thru V1260356

Electrical Components		
Item	Description	Qty.
1	Screw (1/4-20 x 1/2")	8
2	Cover	1
3	PC Board	1
4	Power Line Filter (Domestic models only)	1
5	a) Isolation Transformer (Domestic models) b) Transformer (Export models)	1
6	Fuse Holder	2
7	Power Cord Inlet	1
8	Power Cord (N. American, 120V, 8 ft) *Note: Export models require accessory: 9A152 International Cordsets.	1
9	Housing (includes nutserts)	1
10	Snap Bushing	3
11	Standoff	6

Models:	625 (-001 /-003)	625-004	
Serial Numbers:	V1266166 thru present	all	

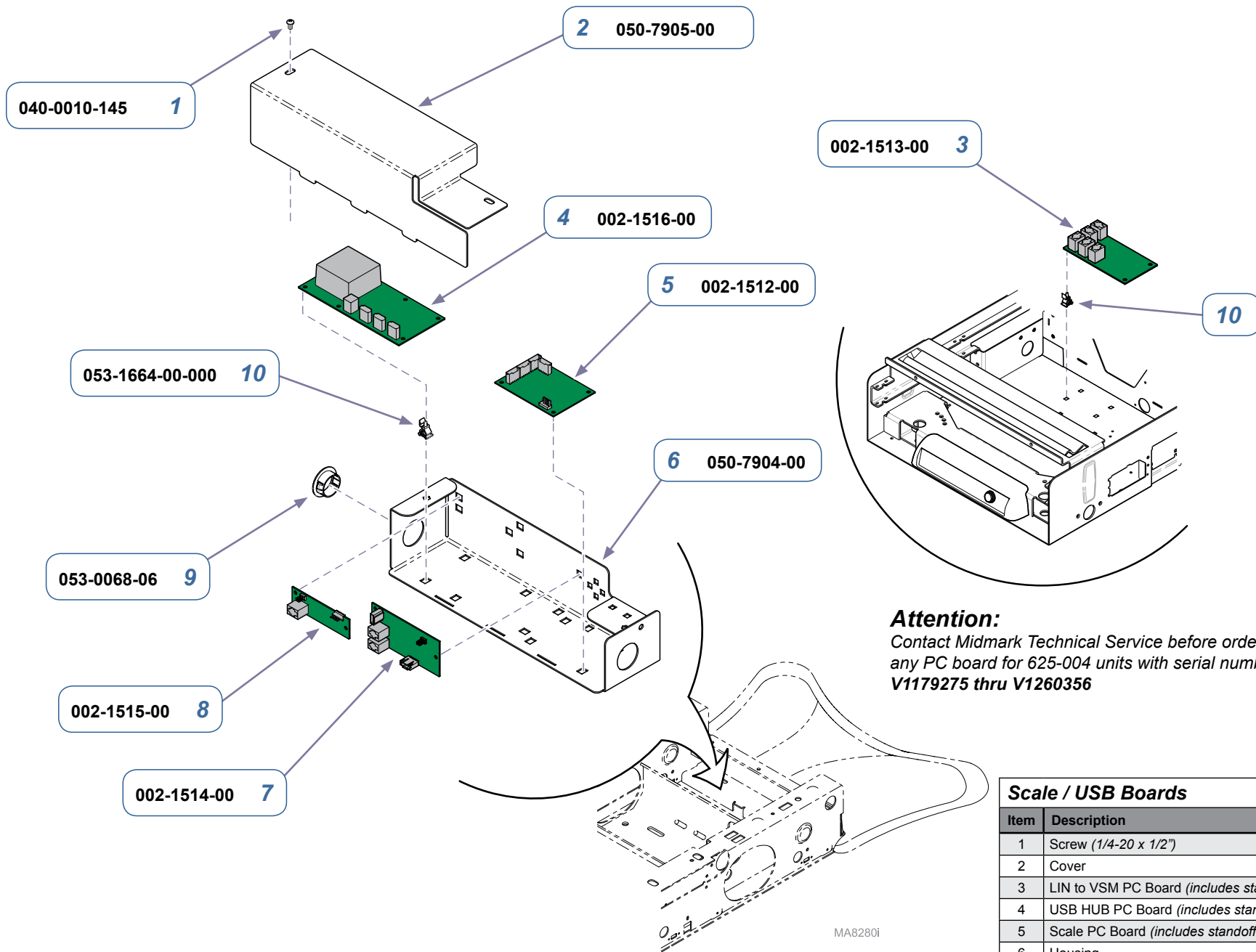

Models:	625-004
Serial Numbers:	<i>all</i>

Scale / USB Boards		
Item	Description	Qty.
1	Screw (1/4-20 x 1/2")	2
2	Cover	1
3	LIN to VSM PC Board (includes standoffs)	1
4	USB HUB PC Board (includes standoffs)	1
5	Scale PC Board (includes standoffs)	1
6	Housing	1
7	625 to USB PC Board (includes standoffs)	1
8	LIN to Scale PC Board (includes standoffs)	1
9	Snap Bushing	3
10	Standoff	21

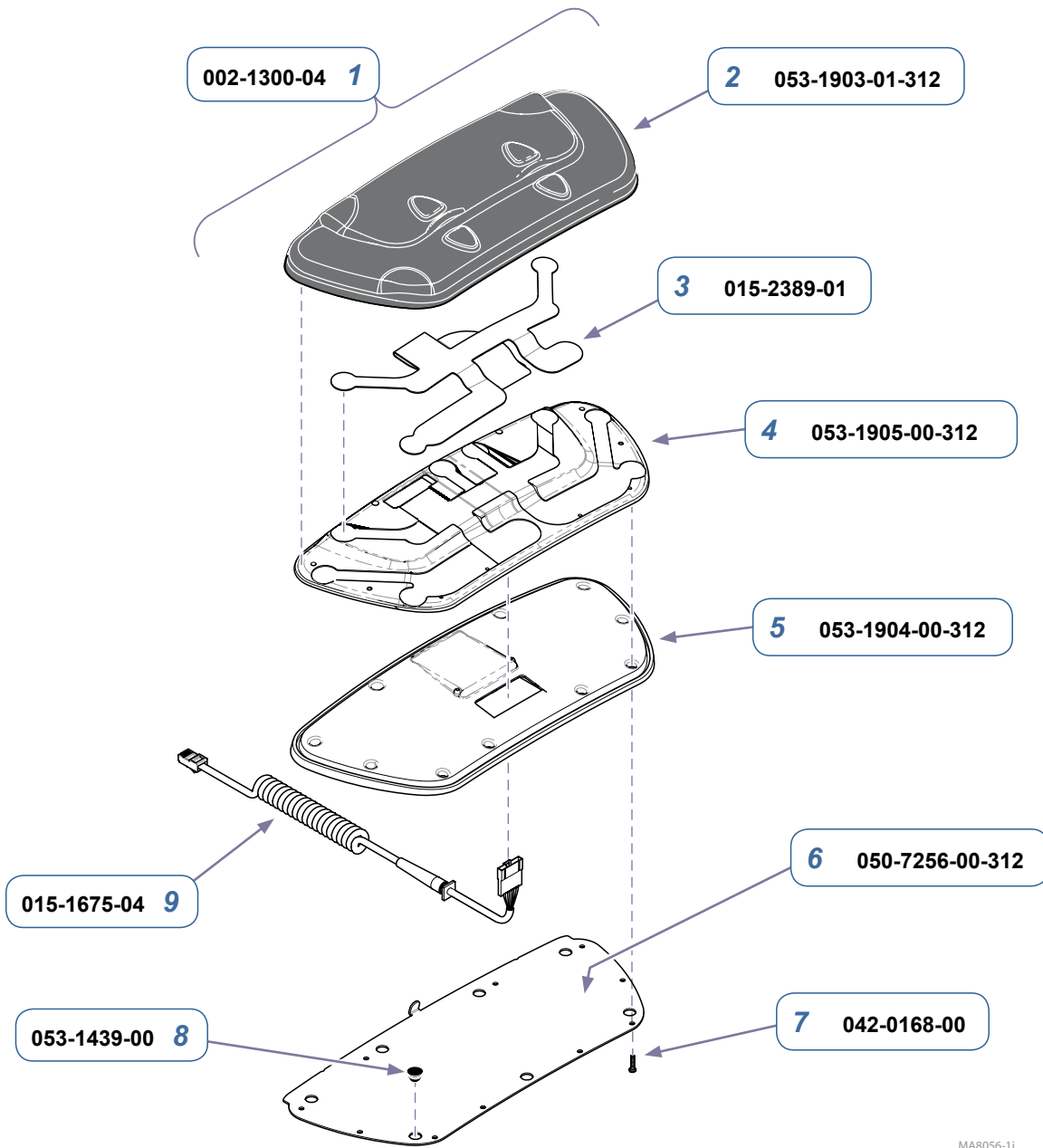

Note
Refer to "Wireless Controls" if applicable.

Foot Control Assembly		
Item	Description	Qty.
1	Foot Control Assembly (incl. items 2 thru 9)	1
2	• Keypad	1
3	• Switch Membrane	1
4	• Retainer	1
5	• Base	1
6	• Baseplate	1
7	• Screw	10
8	• Stem Bumper	7
9	• Cord	1

Models: 625 (-001 /-005 /-006)

Serial Numbers: all

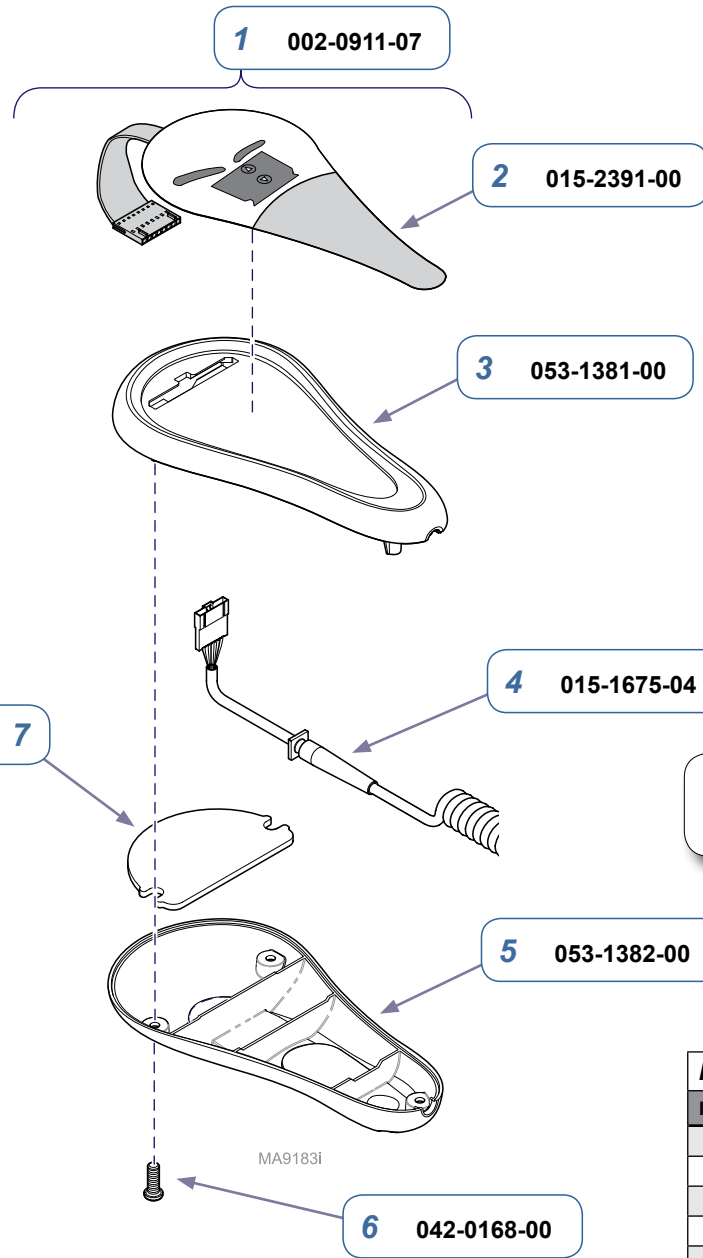
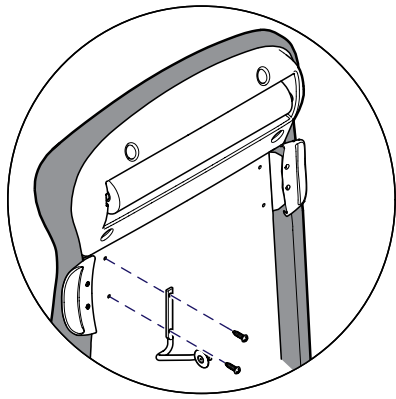

Note
Refer to "Wireless Controls" if applicable.

Hand Control Assembly		
Item	Description	Qty.
1	Hand Control Assembly (incl. items 2 thru 8)	1
2	• Switch Membrane	1
3	• Housing - Top	1
4	• Cord	1
5	• Housing - Bottom	1
6	• Screw (ATF PT K35 x 10 cross recess pan hd.)	4
7	• Weight	1
8	• Hand Control Holster	1
9	Hand Control Bracket Assembly (incl. item 10)	1
10	• Screw (#10-24 x 3/8" pan head phillips)	2

Models:	625 (-001 /-005 /-006)
Serial Numbers:	<i>all</i>

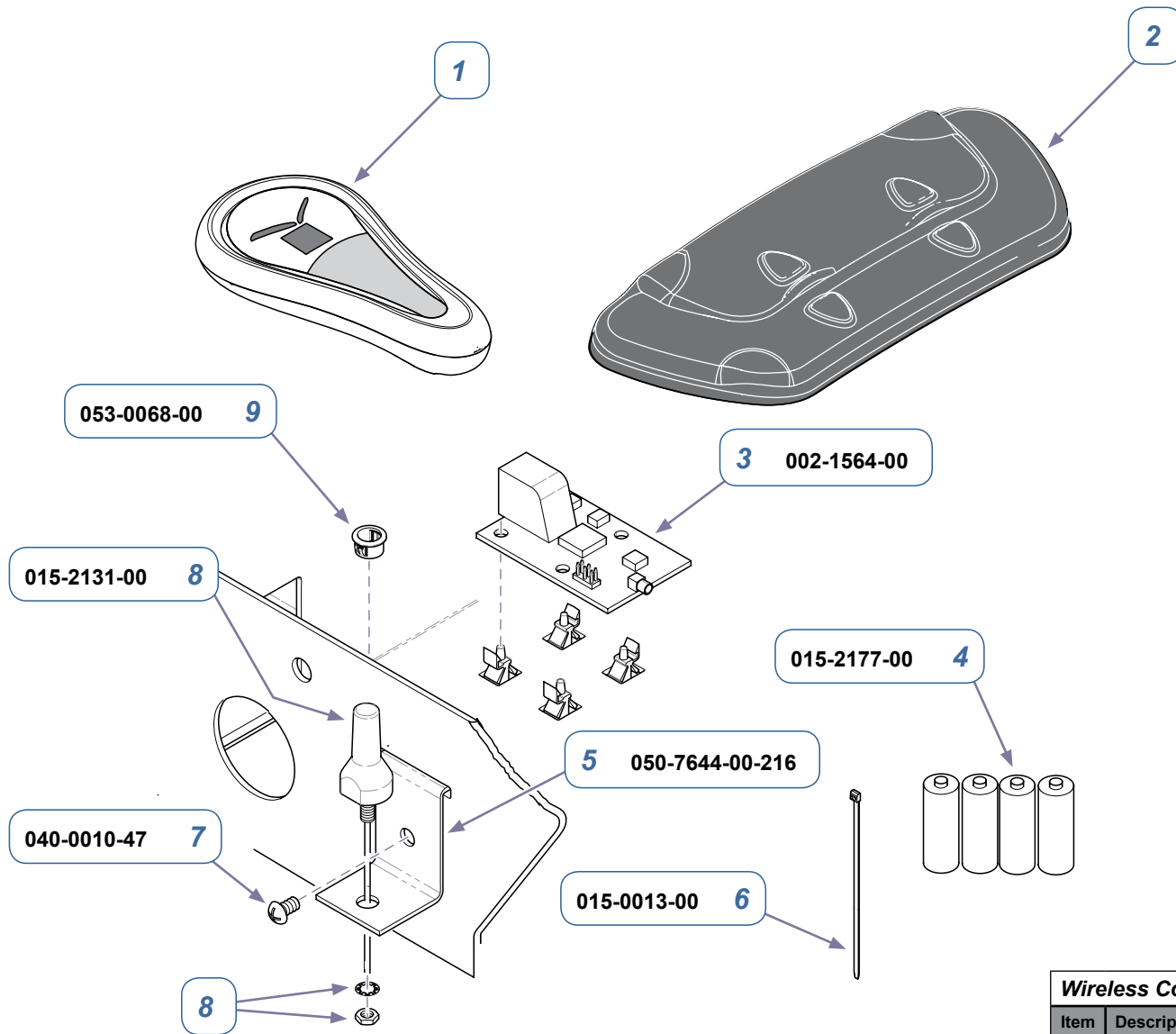

MA84511

Wireless Controls		
Item	Description	Qty.
1	Refer to: Wireless Hand Control	1
2	Refer to: Wireless Foot Control	1
3	Base Station PC Board	1
4	Batteries (size: AA)	4
5	Antenna Bracket	1
6	Cable Tie	1
7	Screw (#10-24 x 3/8*)	1
8	Antenna (includes wire, lockwasher, & nut)	1
9	Snap Bushing	1

Models:	625-003
Serial Numbers:	V968528 thru V1266165

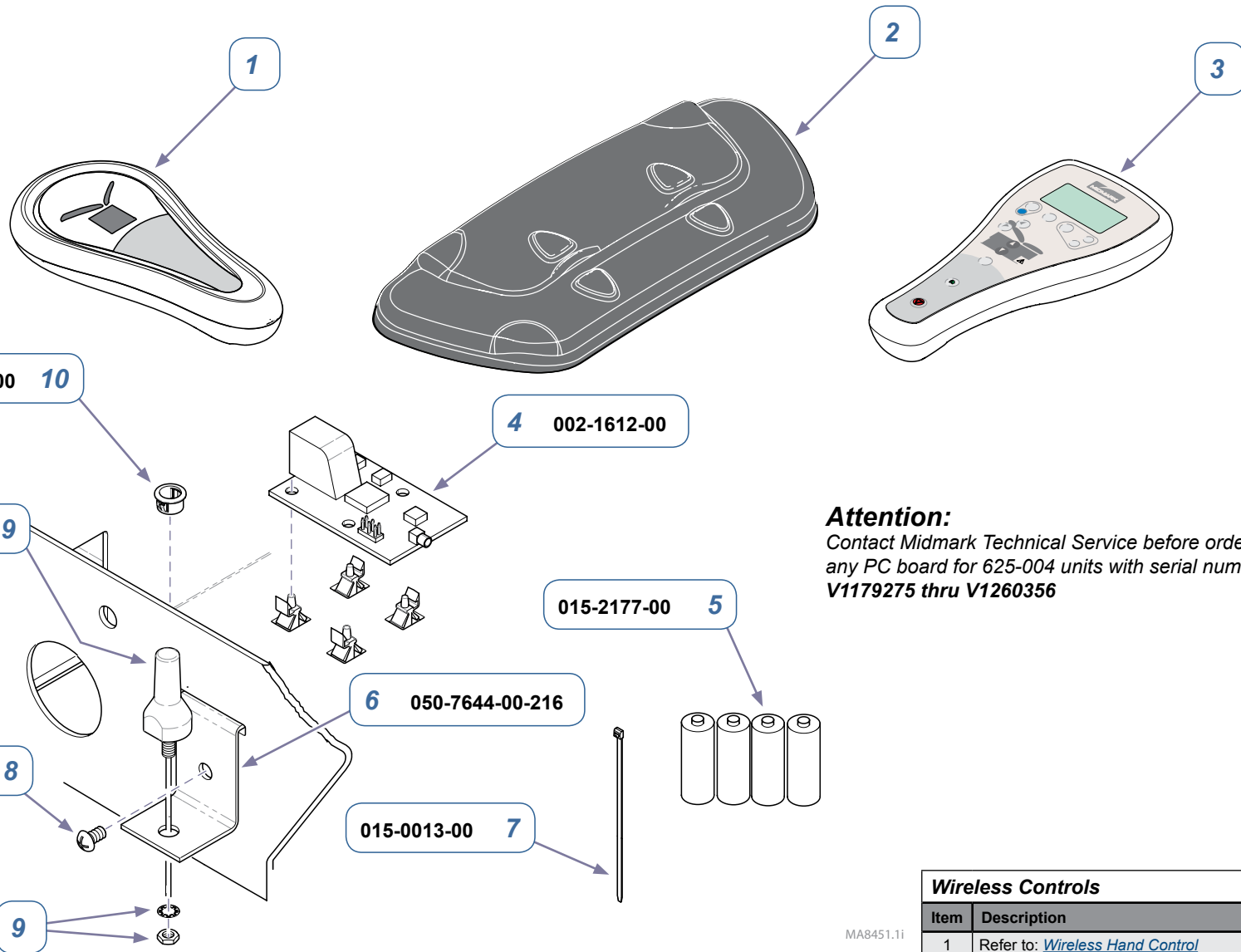

Attention:

Contact Midmark Technical Service before ordering any PC board for 625-004 units with serial numbers V1179275 thru V1260356

Wireless Controls		
Item	Description	Qty.
1	Refer to: Wireless Hand Control	1
2	Refer to: Wireless Foot Control	1
3	Refer to: Wireless Hand Control (w/ Scale)	1
4	Base Station PC Board	1
5	Batteries (size: AA)	4
6	Antenna Bracket	1
7	Cable Tie	1
8	Screw (#10-24 x 3/8*)	1
9	Antenna (includes wire, lockwasher, & nut)	1
10	Snap Bushing	1

MA8451.1i

Models:	625-003	625-004	
Serial Numbers:	V1266166 thru present	all	

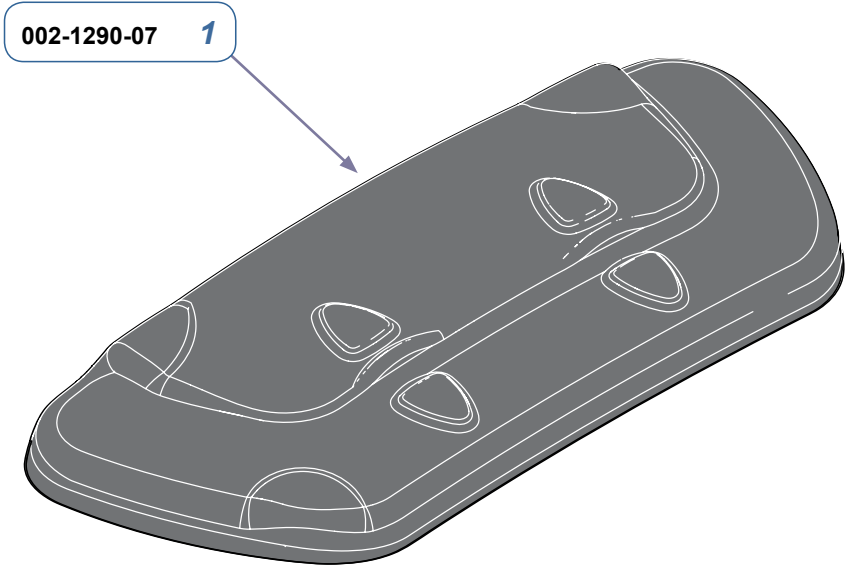

MA8942i

Models:	625 (-003 /-004)
Serial Numbers:	<i>all</i>

Wireless Foot Control Assembly		
Item	Description	Qty.
1	Foot Control Assembly	1

002-1076-02 1

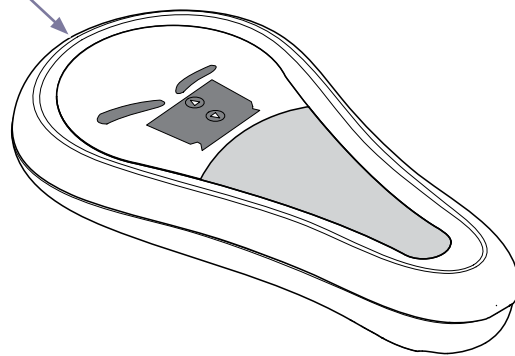

MA89411

Models:	625 -003	
Serial Numbers:	<i>all</i>	

Wireless Hand Control Assembly		
Item	Description	Qty.
1	Hand Control Assembly	1

1 002-1076-03

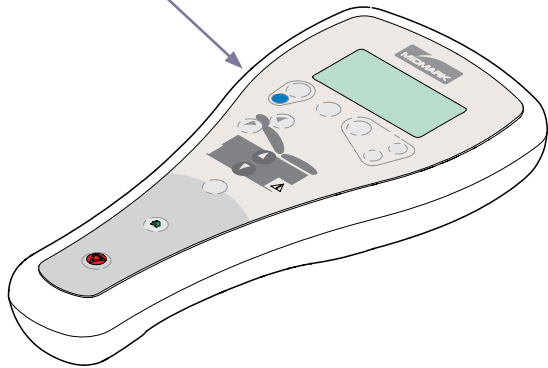

MA8942i

Models:	625-004	
Serial Numbers:	<i>all</i>	

Wireless Hand Control w/ Scale Assembly		
Item	Description	Qty.
1	Hand Control Assembly	1

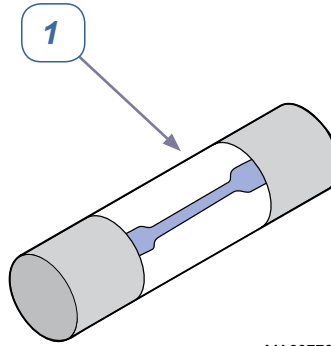

MA637700i

Fuse:	Location:	Function affected	Rating	Midmark Part Number
Isolation Transformer Fuses (2)	IEC Inlet	Electrical Receptacle	6.3A, 250V, Slo-Blo, 5 x 20 mm	015-0346-20
Primary Fuses (2)	Main PC Board [F1 & F2]	Base & Back Functions	10A, 250V, Slo-Blo, 5 x 20 mm	015-0346-42
Transformer Fuse	Main PC Board [F3]	Base & Back Functions	160mA, 250V, Slo-Blo, 5 x 20 mm	015-0346-38
Base & Back Motor Fuse	Main PC Board [F4]	Base & Back Functions	6.3A, 250V, Slo-Blo, 5 x 20 mm	015-0346-40
Drawer Heater Fuses (2)	Distribution Board	Drawer Heater	800mA, 250V, Slo-Blo, 5 x 20 mm	015-0346-25
Transformer 230V / 115V (Export models only)	IEC Inlet	All	6.3A, 250V, Slo-Blo, 5 x 20 mm	015-0346-20

Models:	625
Serial Numbers:	<i>all</i>

Fuses		
Item	Description	Qty.
1	Refer to chart for detailed descriptions	-

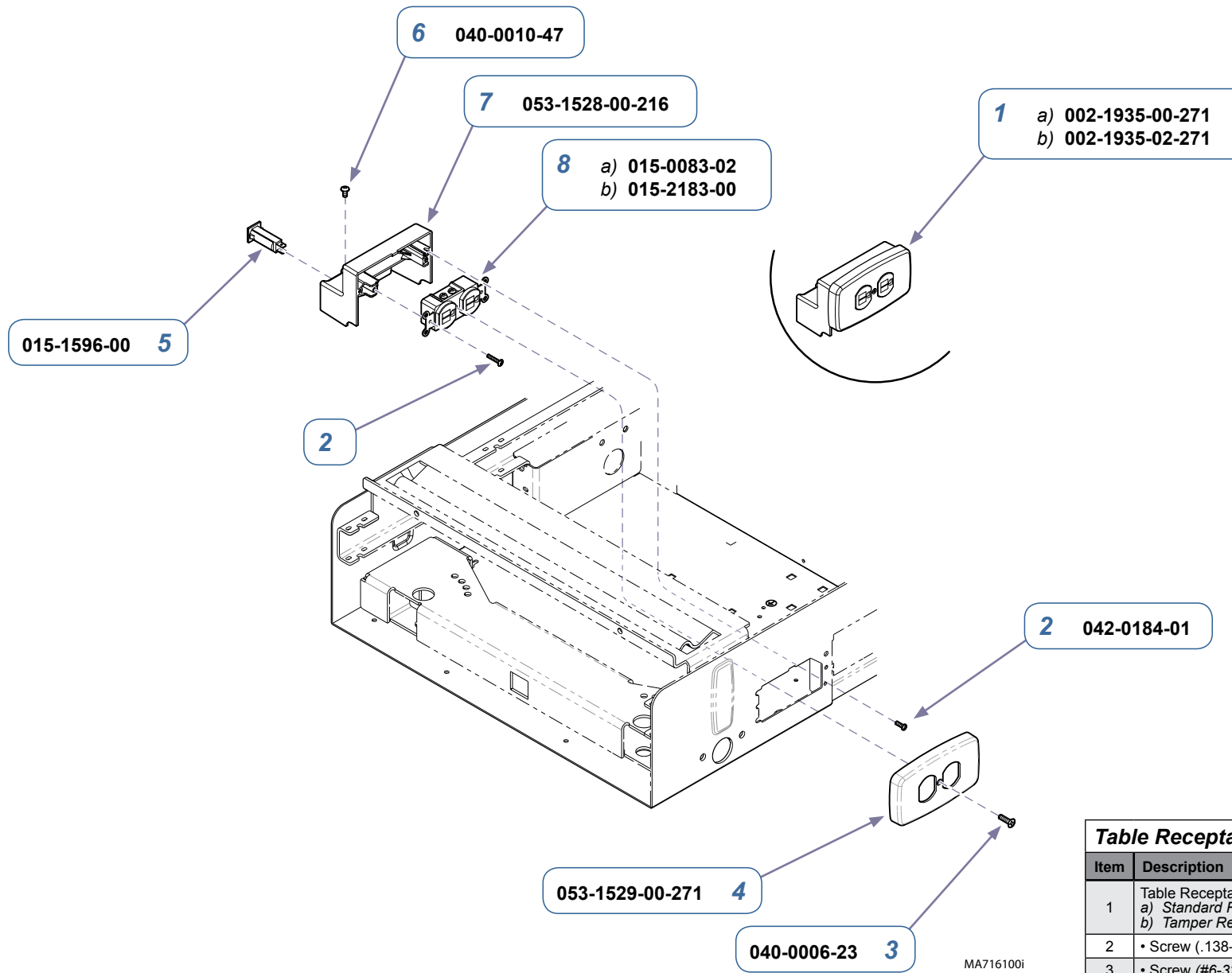

Table Receptacle System		
Item	Description	Qty.
1	Table Receptacle Assy (includes items 2 thru 8) a) Standard Receptacle (black) b) Tamper Resistant Receptacle (white)	1
2	• Screw (.138-32 x 1/2")	4
3	• Screw (#6-32 x 1/2")	1
4	• Receptacle Cover	1
5	• Circuit Breaker (5 amp)	2
6	• Screw (#10-24 x 3/8")	1
7	• Circuit Breaker Housing	1
8	• Duplex Receptacle: a) Standard (black) b) Tamper Resistant (white)	1

Models: 625 (-001 /-003)

Serial Numbers: V2200 thru V1149713

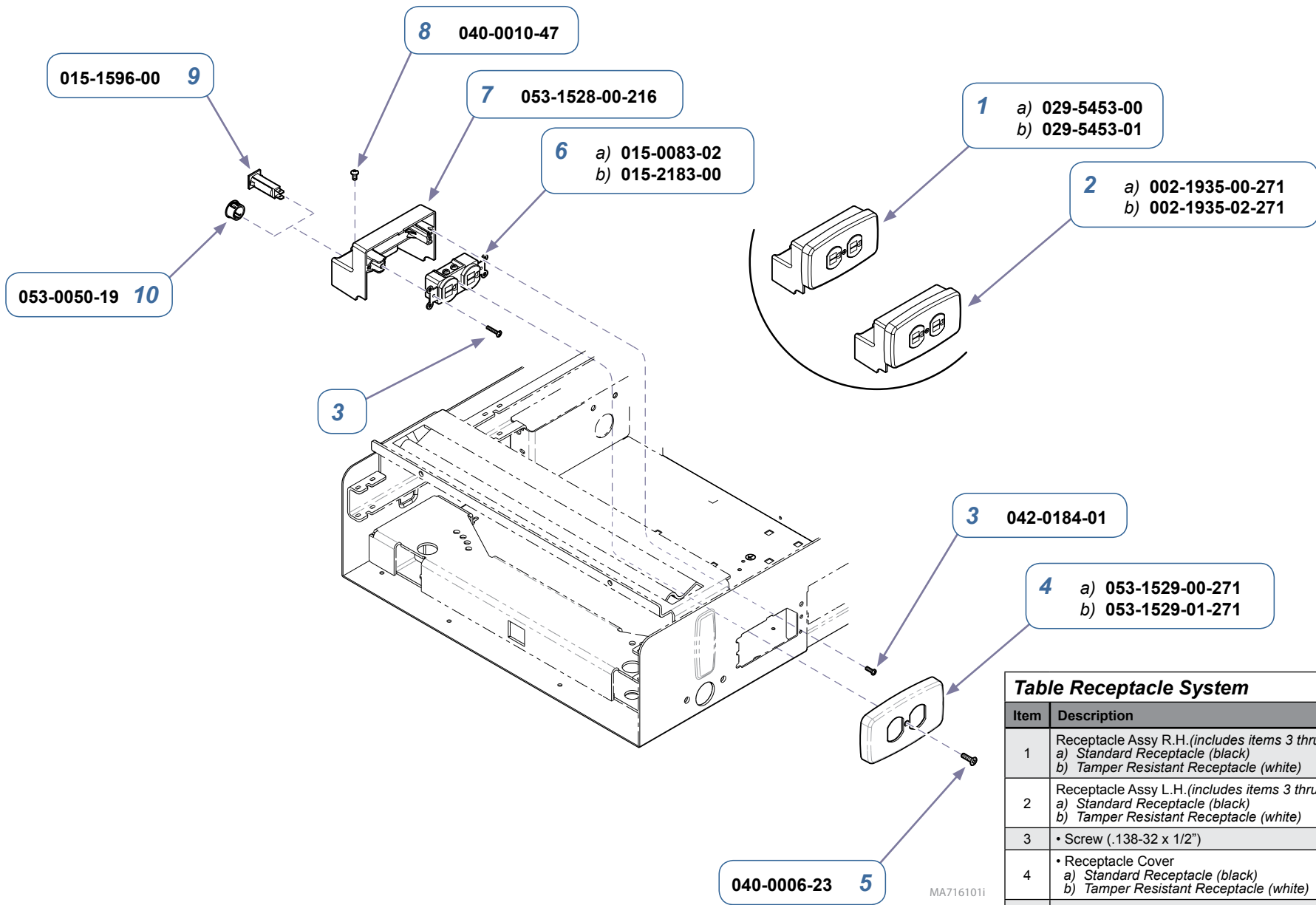

Table Receptacle System		
Item	Description	Qty.
1	Receptacle Assy R.H. (includes items 3 thru 8 & 10) a) Standard Receptacle (black) b) Tamper Resistant Receptacle (white)	1
2	Receptacle Assy L.H. (includes items 3 thru 9) a) Standard Receptacle (black) b) Tamper Resistant Receptacle (white)	1
3	• Screw (.138-32 x 1/2")	8
4	• Receptacle Cover a) Standard Receptacle (black) b) Tamper Resistant Receptacle (white)	2
5	• Screw (#6-32 x 1/2")	2
6	• Duplex Receptacle: a) Standard (black) b) Tamper Resistant (white)	2
7	• Circuit Breaker Housing	2
8	• Screw (#10-24 x 3/8")	2
9	• Circuit Breaker (5 amp)	2
10	• Hole Plug	2

Models: 625 (-001 /-003)
Serial Numbers: V1149714 thru Present

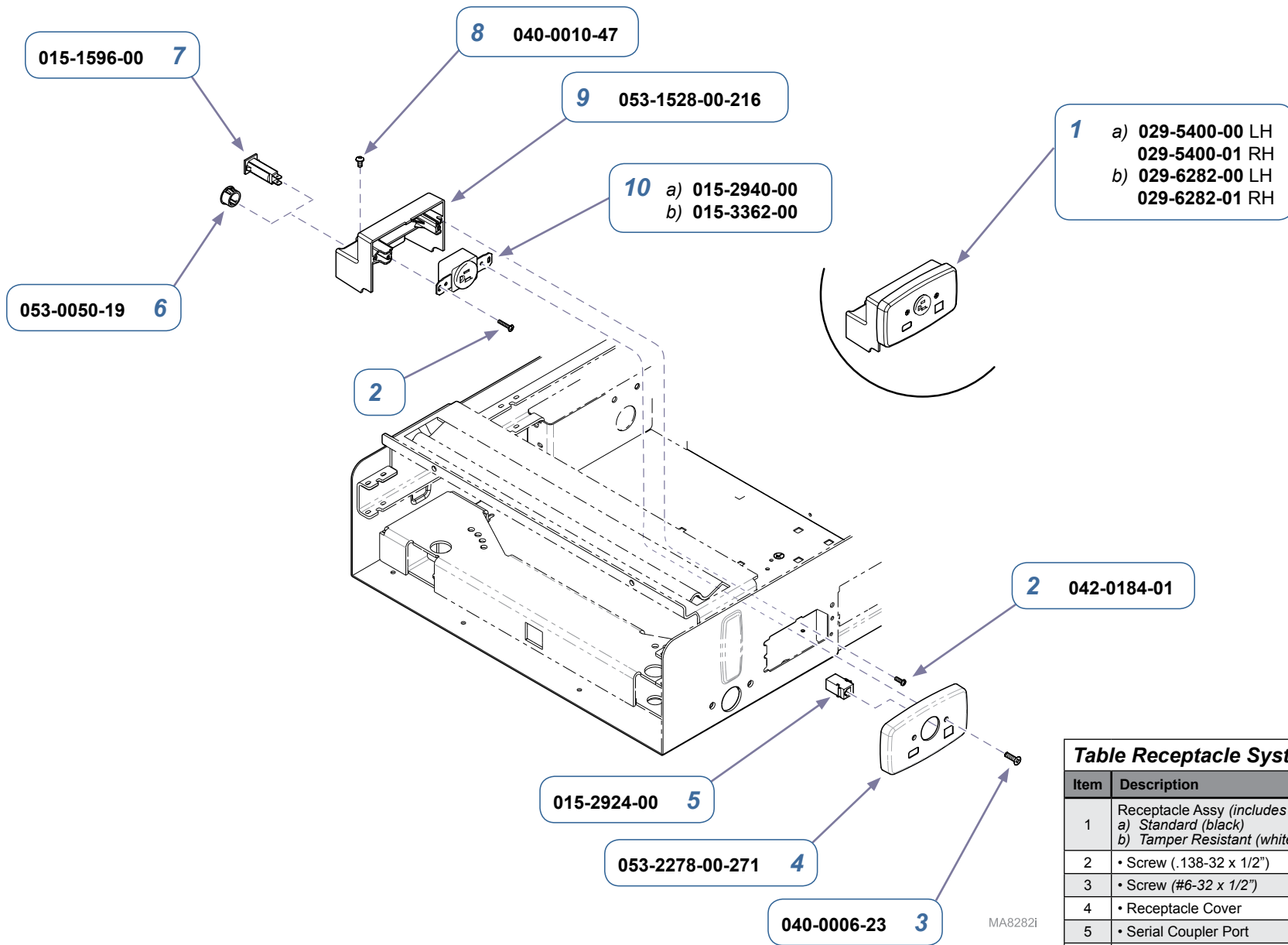
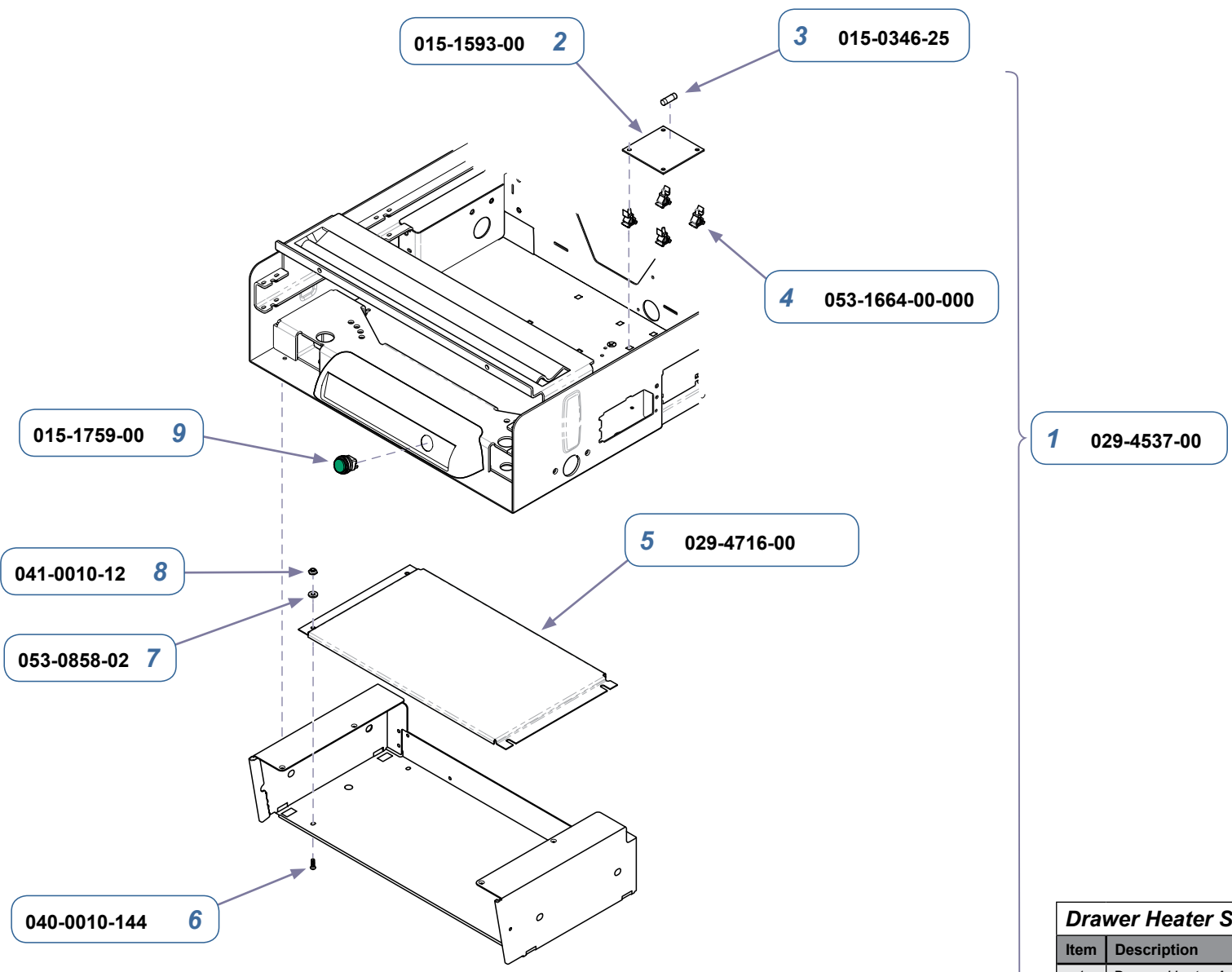

Table Receptacle System

Item	Description	Qty.
1	Receptacle Ass'y (includes items 2 thru 10) a) Standard (black) b) Tamper Resistant (white)	2
2	• Screw (.138-32 x 1/2")	8
3	• Screw (#6-32 x 1/2")	4
4	• Receptacle Cover	2
5	• Serial Coupler Port	2
6	• Hole Plug	2
7	• Circuit Breaker (5 amp)	2
8	• Screw (#10-24 x 3/8")	2
9	• Circuit Breaker Housing	2
10	• Simplex Receptacle a) Standard (black) b) Tamper Resistant (white)	2

Models:	625-004
Serial Numbers:	<i>all</i>



MA8034i

Models:	625 (-001 /-003 /-004 /-006)
Serial Numbers:	<i>all</i>

Drawer Heater System		
Item	Description	Qty.
1	Drawer Heater Assy. (includes items 2 thru 11)	1
2	• Distribution Board (includes item 3)	1
3	•• Fuse (800mA, 250V, Slo-Blo, 5 x 20mm)	2
4	• PC Board Standoff	4
5	• Heater Plate Assembly (incl. items 6 thru 8)	1
6	•• Screw (10-32 x 1/2")	4
7	•• Nylon Washer	4
8	•• Nylon Nut	4
9	• Drawer Heater Switch	1

SUBJECT TO CHANGE WITHOUT NOTICE



Because we care.