

CONTRIGA

Superior technology – outstanding design



Edgebanders



Your partner for productivity and precision



CONTRIGA

Modular, multifunctional, maximum performance

Data to enthuse over



CONTRIGA demonstrates its advantage for edgebanding in all sectors.

- Continuous feed up to 30 m/min
- Edging cross section up to 30 x 65 mm
- Workpiece thickness up to 60 mm
- Space-saving sliding hoods
- Guide for the chain running rail as a round or flat guide
- Extremely thick and stable industrial chain for transporting workpieces
- Stable and strong guide for the pressure bridge
- Pressure bridge with motor-driven height adjustment
- Run-in area with motor-driven adjustable run-in plane
- Two central dust extraction connections
- Oil injector for automatic lubrication of chain links, joints and pins
- Extendable workpiece support (up to 1777 mm)

The CONTRIGA series is a future-oriented milestone for edgebanders. It has been designed for absolute maximum performance. For its charismatic design and choice of new materials, it received the internationally renowned red dot design award. One outstanding feature is the pneumatically controlled hoods. Compared to conventional hoods, this design

takes up much less space. A CONTRIGA machine is configured and constructed according to the customer's individual requirements. The range of available equipment includes more than 60 modules, making it possible to take account of all those demands placed on edgebanders by large workshops and industry.

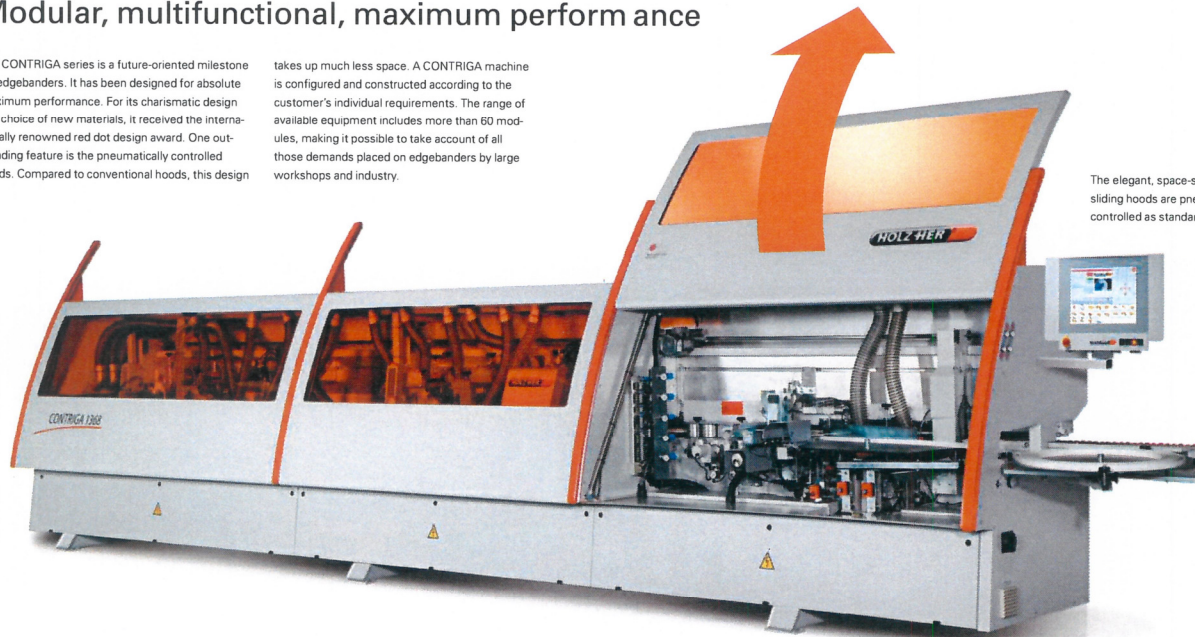

The elegant, space-saving sliding hoods are pneumatically controlled as standard.



Belt guide – gentle, precise and reliable

Regardless of its thickness, the panel material has to be guided in a precise manner through the machining line. This requires a secure hold but without causing any damage. The continuous transport belt in the CONTRIGA pressure bridge ensures an even and smooth feed. Even short or narrow workpieces are guided at a constant speed through all machining stations in a gentle, precise and reliable manner.

EQUIPMENT

Perfectly equipped down to the last detail

Setting standards means that even the smallest detail has to be perfect. The CONTRIGA, designed for continuous operation in industry, demonstrates its perfection in terms of technology and design.

- Motor-driven adjustable run-in linear stop (Fig. 1)
- Oil injector of industrial design for automatic lubrication of the transport chain (Fig. 3)
- Additional equipment for feeding in narrow and long workpieces at right angles (Fig. 4) (optional)
- Stable run-in linear stop with pneumatic blocking roller for short workpiece spacings and high productivity (Fig. 5)
- Stable transport chain of industrial design (Fig. 3)
- Strong design – chip-collecting box integrated flush with the surface (Fig. 6)

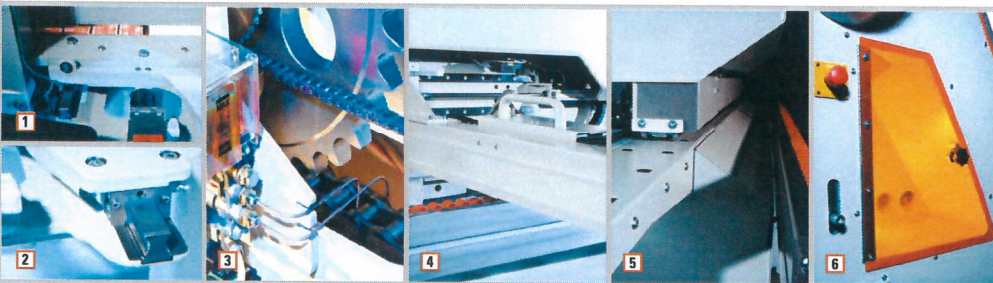

Control system PPC 231 – high-performance and convenient to use

- Touchscreen for easy and direct operation
- Windows-like user interface – all information displayed in plaintext and/or graphic form
- Rotatable and tiltable control panel at eye level
- Integrated keyboard
- Program list showing program names and numbers
- Substantial program memory
- Individual selection of units with the functions as basic setting possibilities for nominal values, path points and tool corrections
- Set-up processes for units and their axis settings carried out centrally and clearly by fine adjustment (depending on equipment)
- Integrated path control – path points are controlled generally or in a program-specific manner
- Clear and complete acquisition of all operating data
- Service reports in plaintext
- Diagnostic system
- Integrated synchronous bus system for high accuracy in controlling the units
- Individual management for up to ten users
- USB port on board
- Ethernet network connection
- Keyboard port on board
- Online maintenance (optional), rapid exchange of data with HOLZ-HER service department
- Barcode interface (optional)
- Connection to HOLZ-HER process data acquisition (HHPDE) system for direct read-out of operating data

Productivity through digital workflow

HOLZ-HER products are unbeatable when combined. The digital workflow between the saws, edgebanders and CNC machining centres allows efficient production. Flexible "manufacturing cells" and "lean manufacturing" are future-proof methods. In conjunction with the HHPDE (HOLZ-HER process data acquisition) software, time-based and computer monitoring and reporting of machine data within the network is also possible.



GLUE APPLICATION SYSTEMS

New slit nozzle – even greater precision

The new nozzle design further optimises the gluing process and allows an extremely thin glued joint. A motor-driven nozzle adjustment system for setting the glue application height is available as an accessory.

- The slit nozzle applies the glue to the panel perfectly and at a pressure of 6 bar.
- Sensing allows precise height adjustment of the system to the panel thickness.

Quality in focus

Unbeatable – glue application systems 1905 and 1907

- Smaller run-in angle due to the nozzle design. Reliable machining of edgings up to 30 mm.
- Glue is applied exactly as required. This saves money and optimises quality.
- There is no discolouring or burning of the glue, since always only the required amount of glue is melted in the closed system.
- One particular advantage is the easy cartridge change, which allows a fast changeover from EVA to PUR glues or even to different glue colours.
- Rational change from glue cartridge to glue granules – simply change the filling shaft and the type of glue.
- Extremely short heat-up time of 3.5 minutes.

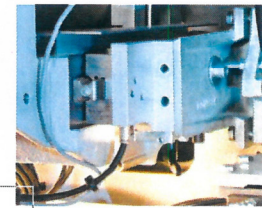
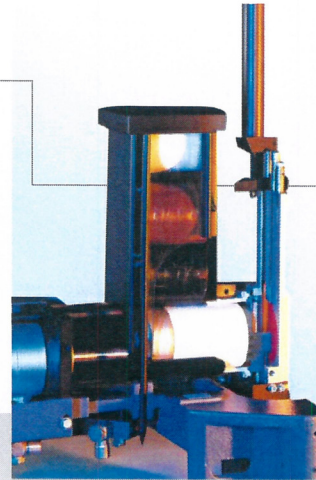

Always a secure join

The gluing stations are pressed against the workpiece on linear guides with pneumatic pre-clamping of the unit, which ensures precise and uniform pressing against the panel. This results in perfect glue application.

For thick panels and rapid feed speeds

With a glue container of 4 kg (granules) and a particularly high melting rate, the ultra-granupress system 1907 is the optimal solution when processing thick panels at rapid feed speeds.

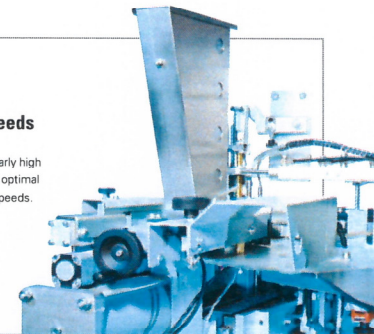

One of a kind – the 1905 multisystem

- For glues in cartridge or granule form
- Can hold up to four cartridges or up to 1.5 kg of granules
- Highly flexible in daily use, time-saving and power-saving
- Easy change of shaft – just fill with new glue and continue working

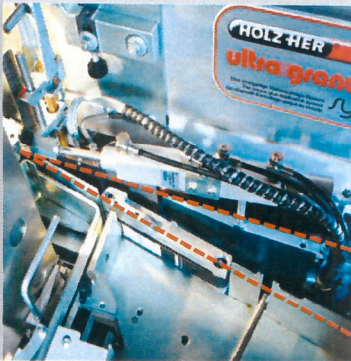
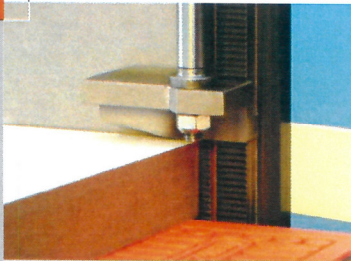

UNITS

Multifunctional units for unlimited performance

One outstanding feature of the CONTRIGA is the possibility of equipping the machine individually with a choice of more than 60 high-performance modules. Thus there are almost no limits to the performance spectrum for edgebanding.

Perfection right from the start

- The run-in area with its adjustable run-in plane offers numerous possibilities for applying edgings.
- The jointing cutter unit ensures tear-free surfaces of the panel materials.
- The magazine of CONTRIGA processes cut-length and coiled edging up to a height of max. 65 mm and a thickness of 30 mm.
- The loading operation is particularly rational since it is possible to change from one edging material to another without using any tools. An automated, six-compartment edging box with monitoring of the remaining length of edging is also available.
- The available glue application systems (see pages 6 and 7) offer the right solution for each application.
- Powerful pressure units finish off the gluing operation perfectly.
- Many units are controlled pneumatically or in a motor-driven manner.

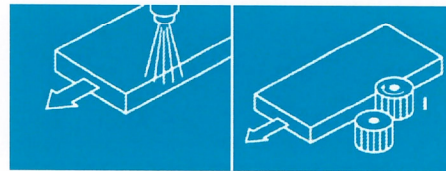
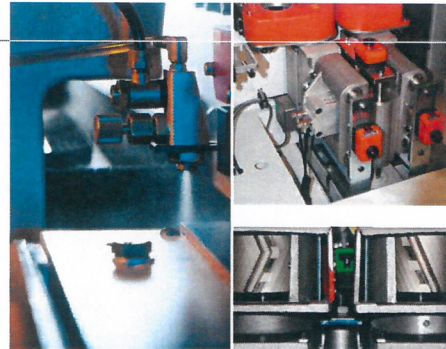

■ Spraying device

Quality right from the start – an anti-adhesion agent prevents glue and dirt from being able to adhere to the panel surfaces (photo shows unit 1856).

■ Jointing cutter unit 1961 (2 x 2 kW)

Cut edgings often have small tears in the top layer. Jointing cutter units ensure flat gluing surfaces and prepare the panels for the gluing process.

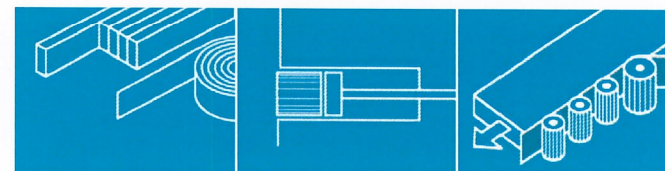
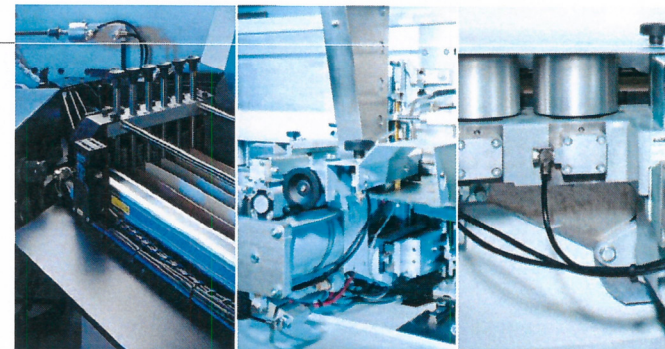

■ Edging feed systems

Automated edging feed systems are an important requirement which allow the user to concentrate on the workpieces (photo shows unit 1805/1901).

■ Glue application station

Glue application stations guarantee a secure hold and clean joints (photo shows unit 1907).

■ Pressure unit 1914 MOT

Four insertion-controlled pressure rollers for a strong pressing pressure and clean gluing of the edging.

UNITS

Post-machining for best quality

The post-machining range, from the end trimming unit to the finishing units, is of a modular design. The high-performance end trimming units and also the flush cutter and multifunctional cutter units offer the possibility of creating a wide range of different radii and chamfers.

- A newly developed corner copying unit and also the four-motor shaping cutter unit ensure that the front edges and the shape of the panel materials, such as post-forming profiles for example, are copied and cleanly machined.
- Units for forming grooves on the rear wall in the forward and backward direction and also front grooving and grinding units can be integrated in the CONTRIGA machine concept without any problem.
- With regard to the finishing units, several possibilities are available starting from the scraping device through the radius scraper and flat scraper to the insertion-controlled or oscillating buffer units.

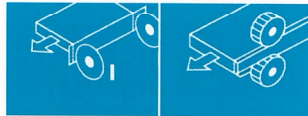
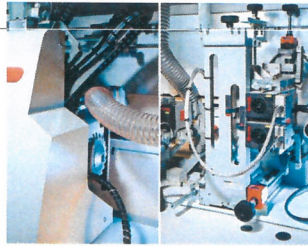

■ Cutting

A large number of high-performance units for flush, radius or chamfer cuts (photo shows unit 1902).

■ End trimming

A tear-free end trimming result even at high feed speeds of up to 30 m/min. Surface-hardened linear guides ensure long-lasting cutting precision (photo shows unit 1819).

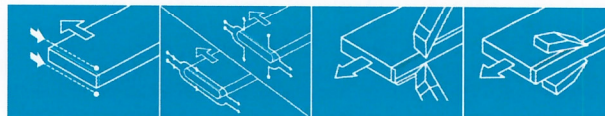
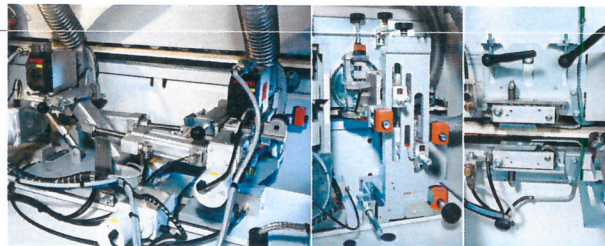

■ Shaping cutting

Shaping cutter units with two or four motors machine the upper and lower and also the front and rear edging overhang. An easy change between radius, chamfer and flush cutting can quickly be carried out (photo shows unit 1833). Manual adjustment

(motor-driven available as an option) of the cutter motors and motor-driven adjustment of the unit as a whole in the Y-direction for automatic change-over between radius and chamfer cuts for thin edgings.

■ Scrapers

Multifunctional scraper units for perfect smoothing of radius and chamfer cuts (photo shows unit 1927).

■ Flat scrapers

Clean post-machining of the surface without the need for manual intervention (photo shows unit 1954).

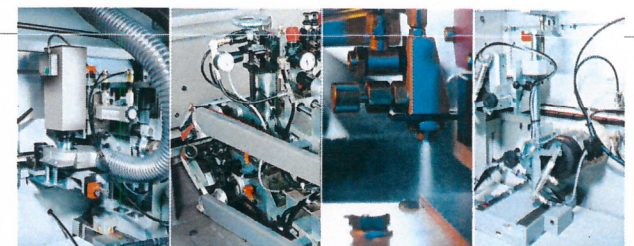

■ Profile cutter units

3.8 kW power. Insertion controlled for surface and front grooving or for folding or profiling (photo shows unit 1932/MO12).

■ Edge grinding units

For surface grinding of solid edgings or for grinding radii (photo shows unit 1937).

■ Spraying device

A special cleaning agent dissolves any glue or dirt left on the edgings and thus further optimises the post-machining (photo shows unit 1856).

■ Buffing

Units for 100% post-machining of edgings and surfaces for absolutely clean finishing and for the perfect glued joint (photo shows unit 1944).

Wide performance spectrum

With different lengths, CONTRIGA adapts precisely to the desired equipment selection and to the individual requirements of companies. Whether machining large edging thicknesses of up to 30 mm or having a high feed speed of up to 30 m/min, the CONTRIGA always guarantees an extremely high quality of the products produced. Right from the start, the CONTRIGA is individually equipped to meet your requirements. One thing that all models have in common is the welded base frame. This ensures unshakable stability, a prerequisite for absolute precision. The CONTRIGA is designed for continuous use in large companies working multi-shift systems.

Model	Free length A (mm inch)	Total length B (mm inch)
CONTRIGA 1363	1825 71.85	6090 239.76
CONTRIGA 1364	2425 95.47	6690 263.39
CONTRIGA 1365	3025 119.09	7290 287.01
CONTRIGA 1366	3625 142.72	7890 310.63
CONTRIGA 1368	4825 189.56	9210 362.60
CONTRIGA 1370	6025 237.20	10410 409.81
CONTRIGA 1372	7225 284.85	11610 457.03

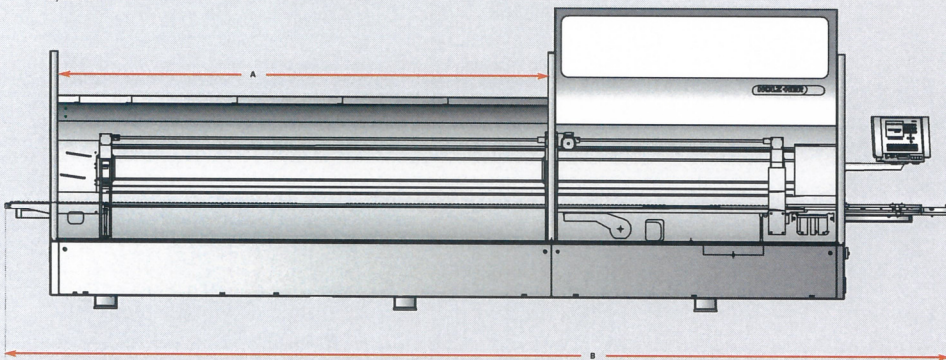

Technical Data

	CONTRIGA 1363 - 1372	
Feed speed		
Max feed speed (continuous) in m/min ft/min	10 - 30	10 - 30
Machine run-in		
Height of run-in phase in mm inch	900	35.43
Blade arrangement		
Minimum air speed in m/s ft/s	20	65.62
Connector (partially encapsulated) ø in mm inch	1 x 200, 1 x 120	1 x 7.87, 1 x 4.72
Connector (fully encapsulated) ø in mm inch	2 x 200	2 x 7.87
Compressed air		
Compressed air connection in bar	6	6

All product brochures available for download at www.holzher.de

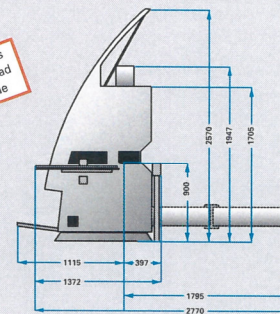

Your authorised HOLZ-HER Spezialmaschinen dealer

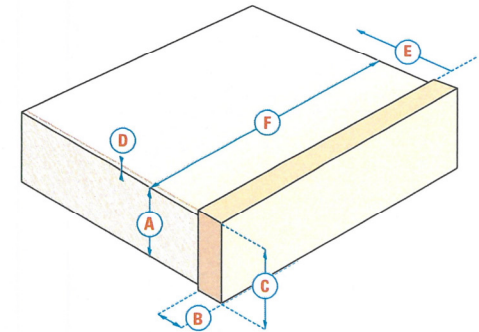

Working dimensions (in mm)		
A	6 - 60	depending on units
B	0,4 - 30	depending on units
C	65	max.
D	2,5	per side
E	60	min.
F	180	

The technical data given are for reference only. We reserve the right to make changes (since HOLZ-HER woodworking machines are subject to constant development). The illustrations are therefore not binding. The machines illustrated may contain special features that are not included as standard. Please ask your HOLZ-HER dealer for details of the features included. We reserve the right to make changes in design and features.

Printed in: 28 February 2006
First edition: 28 February 2006

REICH
Spezialmaschinen GmbH
D-72608 Nürtingen

Tel.: +49 (0) 70 22 702-0
Fax: +49 (0) 70 22 702-101
www.holzher.de

HOLZ-HER