

Quadra-Powr® X Spring Diaphragm Actuators

Installation, Maintenance and
Operating Instructions



Table of Contents

1	GENERAL	3
1.1	Warning	3
1.2	Handling <i>Quadra-Powr X</i> Actuators	3
2	INSTALLATION	3
2.1	Operation.....	4
3	MAINTENANCE	4
3.1	Disassembly	4
3.2	Assembly	5
3.3	Exploded View	6
3.4	Parts List/Bill of Materials.....	7
4	ACCESSORIES	7
5	REPAIR KITS/SPARE PARTS	7

1 GENERAL

This instruction manual contains important information regarding the installation, operation and troubleshooting of Jamesbury® *Quadra-Powr X* Spring-Diaphragm Actuators. This unique spring-diaphragm actuator designed for rotary valves provides safe, smooth and reliable valve actuation at minimal pressures and up to 100 psi (6.9 BAR). Please read these instructions carefully and save them for further reference.

1.1 WARNING

KEEP HANDS AND CLOTHING AWAY FROM THE VALVE PORTS AT ALL TIMES.

DO NOT ATTEMPT TO DISASSEMBLE THE SPRING CARTRIDGE. DISASSEMBLY OF THE SPRING PACKAGE MAY RESULT IN SERIOUS PERSONAL INJURY. IF MAINTENANCE IS REQUIRED, THE ENTIRE ACTUATOR MUST BE RETURNED TO JAMESBURY.

SHUT-OFF AND BLEED ALL SUPPLY LINES BEFORE INSTALLATION OR SERVICING. DO NOT REMOVE DIAPHRAGM CASING HEX HEAD SCREWS (27), NUTS (29) OR DIAPHRAGM CASING (15) WHILE ACTUATOR IS PRESSURIZED.

BEFORE INSTALLING THE VALVE AND ACTUATOR, BE SURE THAT THE INDICATOR POINTER ON TOP OF THE ACTUATOR (AND THE IDENTIFICATION PLATE IN FEMALE ACTUATORS) ARE CORRECTLY INDICATING THE VALVE POSITION. FAILURE TO ASSEMBLE THESE PRODUCTS TO INDICATE THE CORRECT VALVE POSITION COULD RESULT IN PERSONAL INJURY.

AN ACTUATOR MUST BE SIZED ACCURATELY FOR PROPER OPERATION. REFER TO INFORMATION ON ACTUATOR END OF STROKE TORQUES AND THE APPROPRIATE VALVE BULLETIN FOR OPERATING TORQUES.

WHEN SERVICING A VALVE ACTUATOR ASSEMBLY, THE BEST PRACTICE IS TO REMOVE THE ENTIRE ASSEMBLY FROM SERVICE. IF THE ACTUATOR IS REMOVED FROM THE VALVE, IT SHOULD BE REMOUNTED ON THAT SAME VALVE AFTER SERVICING IS COMPLETED. THE ACTUATOR MUST BE READJUSTED FOR PROPER OPEN AND CLOSE POSITION EACH TIME IT IS REMOUNTED.

ACTUATORS ARE NOT TO BE LIFTED USING THE 3/8" NPT IN THE DIAPHRAGM CASING. HANDLING OF THE ACTUATOR IS ACCOMPLISHED BY USING LIFTING STRAPS. SEE SECTION 1.2.

1.2 Handling *Quadra-Powr X* Actuators

Handling of the actuator is to be accomplished by using lifting straps. (See **Table 1**) for approximate actuator weights. Follow (**Figure 1**) for proper strap lifting technique.

2 INSTALLATION

1. Check to see that the position indicator on the actuator is assembled correctly for the desired failure mode, either spring-to-close or spring-to-open. In the spring-to-close mode, the actuator will cycle clockwise to close upon loss of pressure. In the spring-to-open mode, the actuator will cycle counterclockwise to open upon loss of pressure.
2. If the actuator is not set up in the configuration desired, remove the four hex head screws (33), indicator plate (12), indicator pointer (24), and remount them on the opposite mounting surface. In the female actuators, the fastener identification plate shows the failure mode of the actuator.

TABLE 1

Handling <i>Quadra-Powr X</i> Actuators	
Actuator Series	Approximate Weight Lb. (kg)
QPX1	23 (10)
QPX2	42 (19)
QPX3	72 (33)
QPX4	117 (53)
QPX5	235 (107)

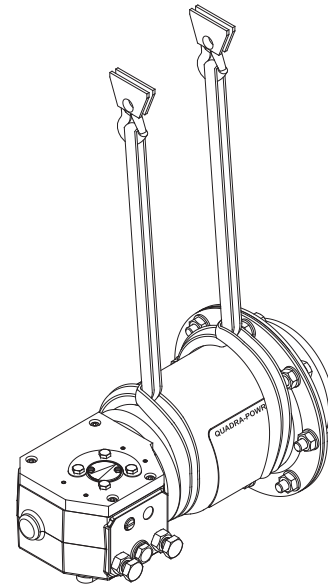
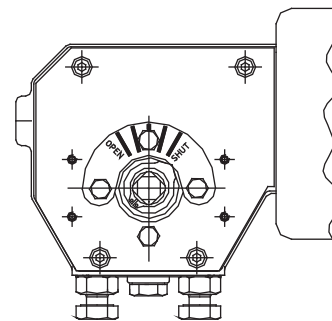

Figure 1

SPRING-TO-CLOSE

In this mode, the actuator will cycle clockwise to close upon loss of pressure



SPRING-TO-OPEN

In this mode, the actuator will cycle counterclockwise to open upon loss of pressure

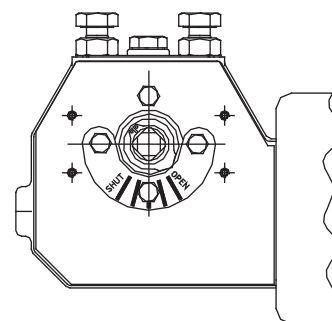

Figure 2

- Mount the actuator to the valve following the directions in the AMI (Actuator Mounting Instructions) or valve IMO.
- Connect a regulated air supply to the 3/8" NPT fitting in the diaphragm casing (15). **CAUTION:** The maximum operating pressure is 100 psi (6.9 BAR).
- Adjust the stop screws (19) by releasing the jam nut (23) and turning. Stops can only be adjusted when driver arm (3) is off the stop screws being adjusted. (Maximum rotation adjustment $\pm 5^\circ$.) Be sure to retighten jam nut (23).

2.1 Operation

The operating pressure, output torque and drive type is determined by the actuator designation. Maximum operating pressure is 100 psi (6.9 BAR). (See **Table 2**)

Actuator designation example: QPX4C/K40 is a series QPX4 spring diaphragm actuator that has a 60 psi (4.1 BAR) spring, an end of stroke output torque of 200 FT•LBS (272 N•m) and uses a 40 mm female key to drive the valve.

Before operating make sure all tapped holes in the body which are not being used are resealed with fasteners.

3 MAINTENANCE

Before working on a *Quadra-Powr X* actuator, note that all fasteners except socket head shoulder screw (8) and hex head cap screw (88, on QPX4 & QPX5) are metric.

Actuator Series	Spring Version	Operating Pressure in psi (BAR)	End of Spring Stroke Torque in FT•LBS (N•m)	Drive Type
QPX1	C	60 (4.1)	25 (34)	K15 - 15 mm Keyed M - 9/16" Square
QPX2	A**	20* (1.4)	11 (15)	K20 - 20 mm Keyed M - 9/16" Square
	B	40 (2.8)	38 (52)	
	C	60 (4.1)	57 (77)	
	D	80 (5.5)	74 (100)	
QPX3	A	20* (1.4)	26 (35)	K35 - 35 mm Keyed M - 3/4" Square
	B	40 (2.8)	76 (103)	
	C	60 (4.1)	114 (155)	
	D	80 (5.5)	146 (198)	
QPX4	B	40 (2.8)	153 (207)	K40 - 40 mm Keyed M - 1" Square
	C	60 (4.1)	229 (310)	
	D	80 (5.5)	294 (399)	
QPX5	B	40 (2.8)	305 (414)	K40 - 40 mm Keyed M - 1" Square
	C	60 (4.1)	458 (621)	
	D	80 (5.5)	587 (796)	

* For Direct Control Applications
 ** QPX2A only available with QPX1 drive type options.

Under normal operating conditions the actuator requires only periodic observation to ensure proper adjustment. Standard replacement of "soft" parts in *Quadra-Powr II* actuators consists of items numbered 6, 14, 31, 62 and 64. See **REPAIR KITS/SPARE PARTS** Section.

- When replacing the diaphragm use caution and be sure the air supply is disconnected. Back off nuts (29) from the hex head screws (27), holding the diaphragm casing and spring housing together until the nuts are flush with the hex head screw ends. Do not remove the nuts completely from the hex head screws. If tension still exists on the hex head screws, then the spring package is not properly contained. Stop disassembly: retighten nuts and return the actuator to the factory. If the spring package proves to be intact remove the nuts (29) and remove the hex head screws (27).
- Lift off diaphragm casing (15). Remove hex head cap screw (88) and retaining washer (89). Remove diaphragm (14).
- Inspect the inside of both the diaphragm casing (15) and the spring housing (32) for any rough spots or foreign matter which may cause abrasion to the diaphragm.
- Place the new diaphragm (14) on the diaphragm retainer (10). Do not pinch or stretch the diaphragm. Attach with washer (89) and cap screw (88). Tighten to value in (**Table 3**) keeping spring housing (32) holes aligned with diaphragm (14) holes. Place the diaphragm casing (15) on the spring housing (32) and line up all the holes.
- Insert hex head screws (27) in all holes. Do not force the hex head screws through the diaphragm. Install nuts (29) on screws and tighten uniformly using the standard practice of tightening diametrically opposite bolts in sequence with the torque requirements from (**Table 3**).

3.1 Disassembly

When disassembly of the actuator is required for maintenance, remove the actuator to a clean well lit area. Handling of the actuator is accomplished by using lifting straps. See Section 1.2.

Prior to disassembling the actuator, obtain the following tools: two (2) M10 wrenches, preferably one being a ratchet, one (1) hex (Allen) wrench, 3 mm for QPX1, 5 mm for QPX2, 3 and 4, 6 mm for QPX5, one (1) screwdriver, one (1) plastic faced mallet.

- Remove the cover (5) by removing six (four on QPX1) socket cap screws (21). If the cover cannot be removed, tap it with a plastic hammer to break the adhesion of the paint between the body and cover joint.
- Use air pressure to remove spring preload by partially stroking the actuator. If the diaphragm (14) is ruptured, replace as instructed in the previous section.
- To remove the socket shoulder screw (8) (or socket cap screw in QPX1) that holds the clevis (7) to the driver arm (3), first apply some heat to the lower arm to loosen the Loctite® on threads of the socket shoulder screw.
- Slowly increase air pressure until the driver arm (3) moves slightly off the stop screw (19). Remove the socket shoulder screw (8).

5. Slowly relieve the air pressure in the actuator. The clevis (7) should be set against the spring retainer (30), and positioned symmetrically about the slot in the spring housing.
6. Shut off and bleed the air pressure to zero. Disconnect the air lines.
7. Remove the hex head screws (27) and hex nuts (29) holding the diaphragm casing and spring housing together.
8. Lift off diaphragm casing (15), remove hex head cap screw (88), washer (89) and diaphragm (14). Inspect the diaphragm for signs of wear, rupture or mechanical damage.
9. Inspect the inside of both the diaphragm casing and spring housing, as well as the outside of the diaphragm retainer for any rough spots or foreign matter which may cause abrasion of the diaphragm.
10. Lift the entire spring cartridge out of the unit

WARNING: DISASSEMBLY OF THE SPRING PACKAGE SHOULD NOT BE ATTEMPTED. SPECIAL EQUIPMENT IS REQUIRED. DISASSEMBLY OF THE SPRING PACKAGE MAY RESULT IN SERIOUS PERSONAL INJURY. IF MAINTENANCE IS REQUIRED SHIP THE ENTIRE ACTUATOR TO JAMESBURY.

It is usually not necessary to remove the spring housing (32) from the body (1). However, if removal is required, heat must be used to loosen the Loctite®. When reassembling, the information in (Table 1), torque and Loctite® recommendations must be met. All fasteners should use Loctite® 271 on the threads. Inspect and clean all components.

Good practice dictates that all bearings should be removed and replaced. See the **SERVICE KIT** section of this IMO for the proper actuator series repair kit number.

3.2 Assembly

To aid assembly, spread light oil or grease on the outside diameter of the new bearings.

1. Press driver arm bearings (6) into the body (1) and covers (5). This is best done in an arbor press, but a vise could be used if care is taken not to damage the bearing. Driver arm bearings are to be pressed in until they are flush or 0.015 in. (0.38 mm) below the body counterbore or the inside cover surface. Press clevis bearings (62) into the clevis (7).
2. Apply lubricant, MOLYKOTE® GN grease on shoulder screw (8) barrel prior to assembly. Also, apply MOLYKOTE® GN grease to driver arm bearings (6).
3. Place the thrust bearing (31) into the counterbore in the body of QPX1-QPX5 actuators. Slide the other thrust bearing onto the trunnion of the driver arm (3). Place the driver in the body.
4. Spring housing (32), diaphragm retainer (10) and springs shall be lubricated with Kendall L-427 Super Blu® or Mobilgrease™ XHP 222. Lower the spring car-

tridge into the spring housing (32). Make sure that the spring package is not resting on the hex head cap screws (38) which hold the spring housing and body together. If bearing (64) has separated from diaphragm retainer (10), hold in place while lowering spring cartridge into housing.

5. Place the new diaphragm (14) on the diaphragm plate. Attach diaphragm (14) to diaphragm retainer (10) using washer (89) and hex head cap screw (88). Torque to the value specified in (Table 3).
6. Insert the hex head bolt (27) in all holes. Do not force the bolts through the diaphragm. Install nuts (29) and tighten uniformly using the standard practice of tightening diametrically opposite bolts in sequence. Follow (Table 3) for tightening torques.
7. Connect a regulated air supply to the pressure port and slowly increase the air pressure until the holes in the clevis and driver arm are aligned. Turn clevis a few degrees, if required, to align holes.
8. Apply Loctite® 271 on the threads of the shoulder screw. Insert it through the driver arm and clevis. Tighten per (Table 3).
9. Back off the nut (74) against clevis (7). Apply Loctite® 271 on the threads of the actuator rod. Tighten nut against clevis by applying torque from (Table 3), as the nut is being tightened, firmly hold the clevis with a wrench, since the unsupported driver arm may tend to tip over.
10. Slowly release air pressure. Assemble cover by using the socket head screws (21). Apply tightening torque per (Table 3).
11. Install the indicator pointer (24) if this was previously disassembled. In female actuators make certain that the indicator points to the inscribed line in the driver arm. In male actuators, hold the indicator pointer in place with a retaining ring (9). **NOTE:** Refer to Installation instructions for spring-to-close or spring-to-open configuration.

TABLE 3					
Torque Requirements					
Required Tightening Torques In FT•LBS (N•m)					
For Various Fasteners					
	QPX1	QPX2	QPX3	QPX4	QPX5
Nuts for Hex Head Screws through Diaphragm Casing (29)	24 (32)	24 (32)	24 (32)	24 (32)	24 (32)
Socket Head Cover Screws (21)	4 (5)	6 (8)	6 (8)	6 (8)	15 (20)
Socket Head Shoulder Screw (8)	35 (48)	55 (75)	132 (179)	132 (179)	132 (179)
Nuts on Actuator Rod (74)	55 (74)	55 (75)	88 (119)	132 (176)	176 (239)
Hex Head Screws between Body and Spring Housing (38)	5 (7)	18 (24)	30 (40)	30 (40)	55 (75)
Hex Head Cap Screws for Attaching Diaphragm to Diaphragm Retainer (88)	19 IN•LBS (1)	19 IN•LBS (1)	27 IN•LBS (2)	10 FT•LBS (14)	17 FT•LBS (23)

3.3 QPX EXPLODED VIEW

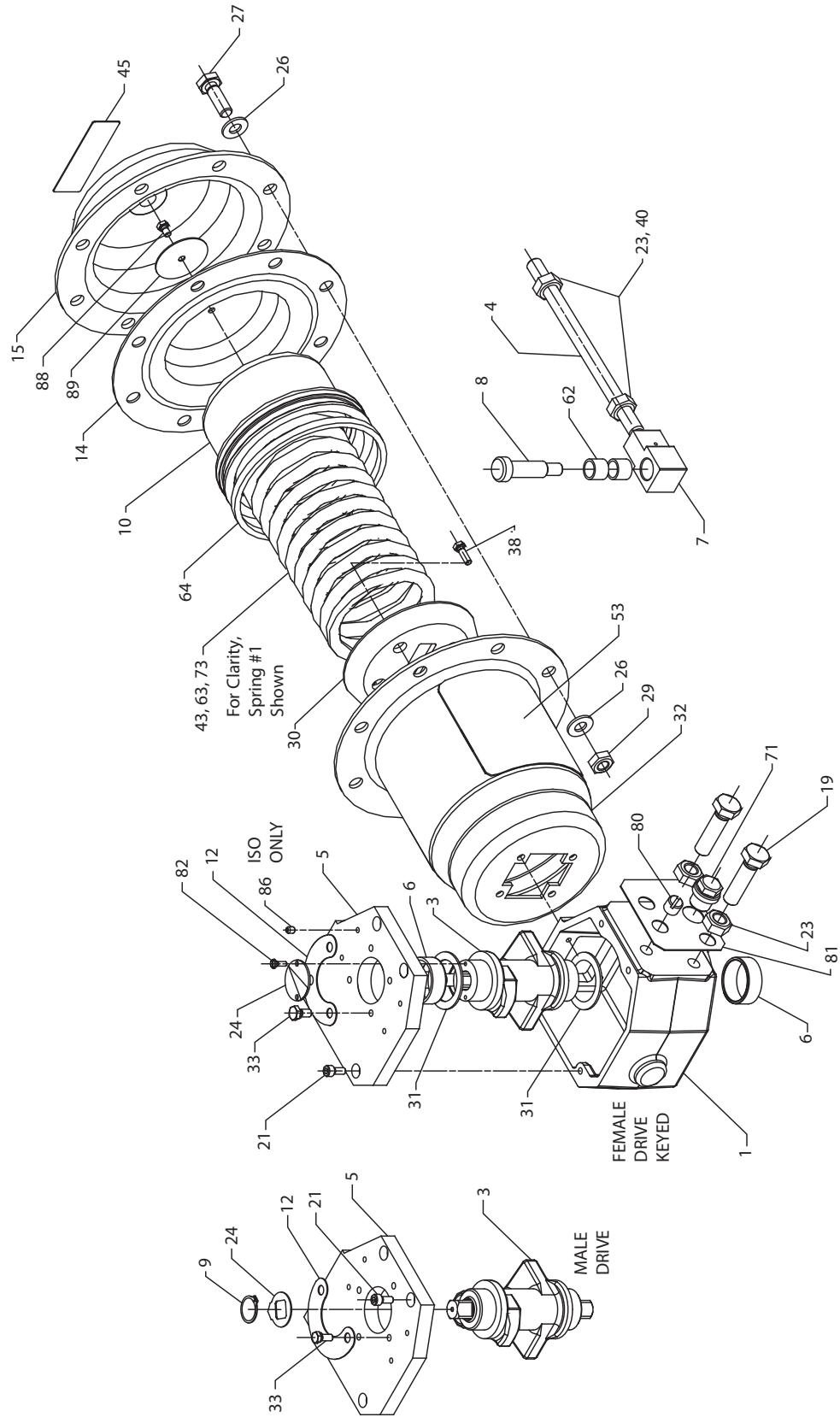

Figure 3

3.4 PARTS LIST AND BILL OF MATERIALS

Bills Of Materials And Parts

ITEM NO.	PART DESCRIPTION	QPX1C/_	QPX2A/_	QPX2B/_	QPX2C/_	QPX2D/_	QPX3A/_ QPX3B/_	QPX3C/_	QPX3D/_	QPX4B/_	QPX4C/_	QPX4D/_	QPX5B/_	QPX5C/_	QPX5D/_
1	Body	1		1				1			1			1	
3	Driver Arm	1		1				1			1			1	
4	Actuator Rod	1		1				1			1			1	
5	Cover	1		1				1			1			1	
6	Bearing-Driver Arm	2		2				2			2			2	
7	Clevis	1		1				1			1			1	
8	Socket Head Shoulder Screw	1		1				1			1			1	
9	Retaining Ring*	1		1				1			1			1	
10	Diaphragm Retainer	1		1				1			1			1	
12	Indicator Plate	1		1				1			1			1	
14	Diaphragm	1		1				1			1			1	
15	Diaphragm Casing	1		1				1			1			1	
19	Hex Head Cap Screw	2		2				2			2			2	
21	Socket Cap Screw	4	4	6	6	6		6			6			6	
23	Hex Jam Nut	3	3	4	4	4		2			2			2	
24	Indicator Pointer	1		1				1			1			1	
26	Washer	16		24				24			32			48	
27	Hex Head Cap Screw	8		12				12			16			24	
29	Centerlock Hex Nut	8		12				12			16			24	
30	Spring Retainer	1		1				1			1			1	
31	Thrust Bearing	2		2				2			2			2	
32	Spring Housing	1		1				1			1			1	
33	Cap Screw	4		4				4			4			4	
38	Cap Screw	4		4				6			10			10	
40	Hex Jam Nut	N/A		N/A				2			2			2	
43	Spring #1	1		1				1			1			1	
45	Caution Plate	1		1				1			1			1	
53	Identification Tag	1		1				1			1			1	
62	Clevis Bearing	2		2				2			2			2	
63	Spring #2	N/A	N/A	N/A	1	1	N/A	1	1	N/A	1	1	N/A	1	1
64	Bearing Strip	1		1				1			1			1	
71	Breather Vent	1		1				1			1			1	
73	Spring #3	N/A	N/A	N/A	N/A	1	N/A	N/A	1	N/A	N/A	1	N/A	N/A	1
80	Set Screw	1		1				1			1			1	
81	Nameplate	1		1				1			1			1	
82	Slotted Pan Head Screw**	2		2				2			2			2	
86	Socket Head Set Screw**	8		8				8			8			8	
88	Hex Head Cap Screw	1		1				1			1			1	
89	Diaphragm Washer	1		1				1			1			1	

*MALE ACTUATORS ONLY.

**FEMALE ACTUATORS ONLY.

4 ACCESSORIES

Quadra-Powr X actuators can be locked in the spring uncompressed mode. Refer to IMO-30 for more information.

Quadra-Powr X actuators can easily be reworked to have 100% adjustability in air stroke. Consult factory if this feature is desired.

Quadra-Powr X actuators are designed with one or two accessory mounting pads; ISO and *Jamesbury* standard. Refer to Figure "5". Consult *Jamesbury* linkage manual for accessory linkage kits.

5 REPAIR KITS/SPARE PARTS

SERVICE KITS		
Model	Complete	Diaphragm
QPX1 Actuator	RKQ-68	RKQ-75
QPX2 Actuator*	RKQ-70	RKQ-76
QPX3 Actuator	RKQ-71	RKQ-77
QPX4 Actuator	RKQ-72	RKQ-78
QPX5 Actuator	RKQ-73	RKQ-79

*Note: QPX2A uses complete kit RKQ-69 and diaphragm kit RKQ-76

For further information on spare parts and service or assistance visit our web-site at www.metso.com/valves.

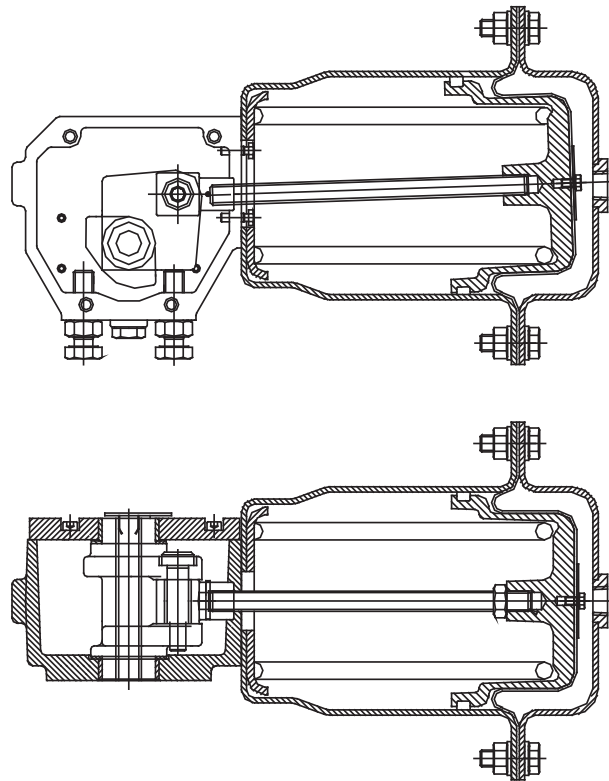

QPX Actuators
Figure 4

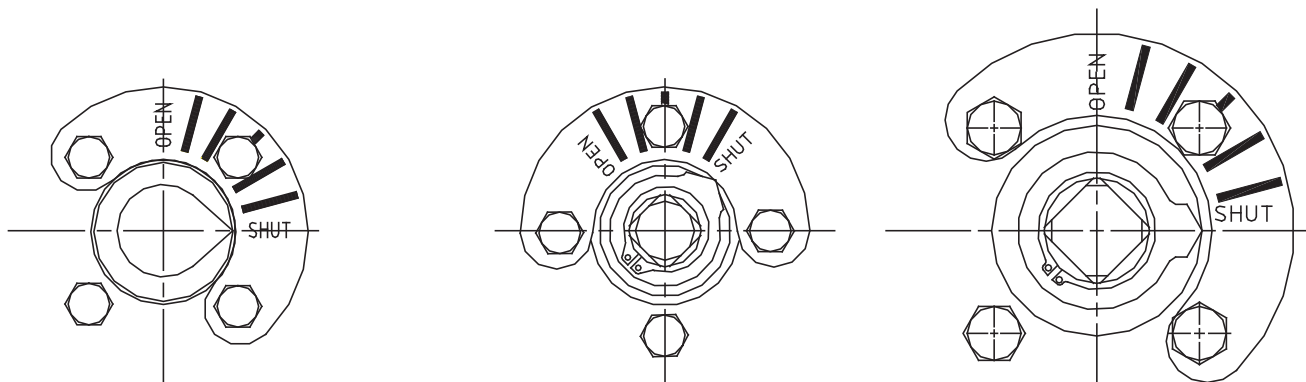

ISO Mount
QPX1, 2, 3, 4, 5, 6

J Mount
QPX1, 2, 4, 5

J Mount
QPX3

QPX1C-QPX2A Actuators
Figure 5

Subject to change without prior notice.

Metso Automation Inc.

Europe, Vanha Porvoontie 229, P.O. Box 304, FI-01301 Vantaa, Finland, Tel. +358 20 483 150, fax +358 20 483 151

North America, 44 Bowditch Drive, P.O. Box 8044, Shrewsbury, Massachusetts, 01545-8044, USA, Tel. +1 508 852 0200, fax +1 508 852 8172

South America, Av. Independência, 2500-Iporanga, 18087-101, Sorocaba-São Paulo, Brazil, Tel. +55 15 2102 9700, fax +55 15 2102 9748/49

Asia Pacific, 20 Kallang Avenue, Lobby B, #06-00, PICO Creative Centre, Singapore 339411, Singapore, Tel. +65 6511 1011, fax +65 6250 0830

China, 19/F, the Exchange Beijing, No. 118, Jianguo Lu Yi, Chaoyang Dist, 100022 Beijing, China, Tel. +86-10-6566-6600, fax +86-10-6566-2575

Middle East, Roundabout 8, Unit AB-07, P.O. Box 17175, Jebel Ali Freezone, Dubai, United Arab Emirates, Tel. +971 4 883 6974, fax +971 4 883 6836

www.metso.com/valves

