

Urschel OV Product Information

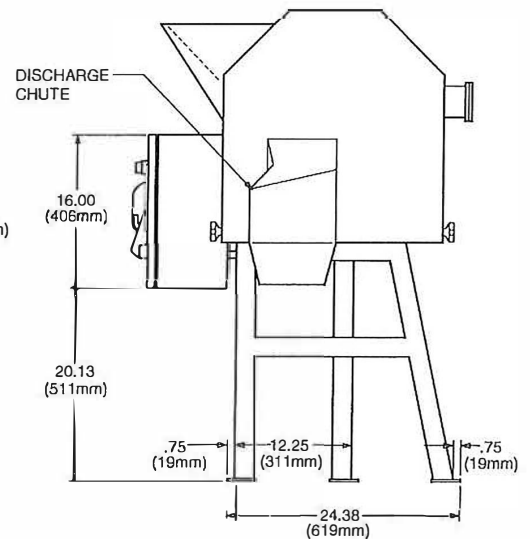

Your Product Can Be Test Cut

Urschel Laboratories has a complete network of test facilities and experienced service and sales representatives around the world ready to work for you on any size reduction application. Contact your local Urschel Laboratories' representative to schedule a comprehensive, no-obligation test today at www.urschel.com.

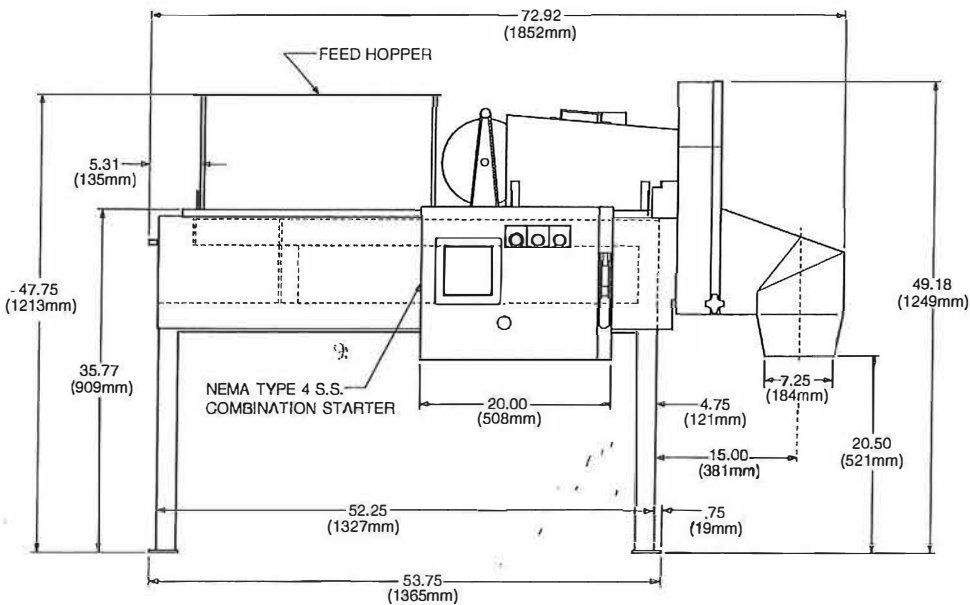
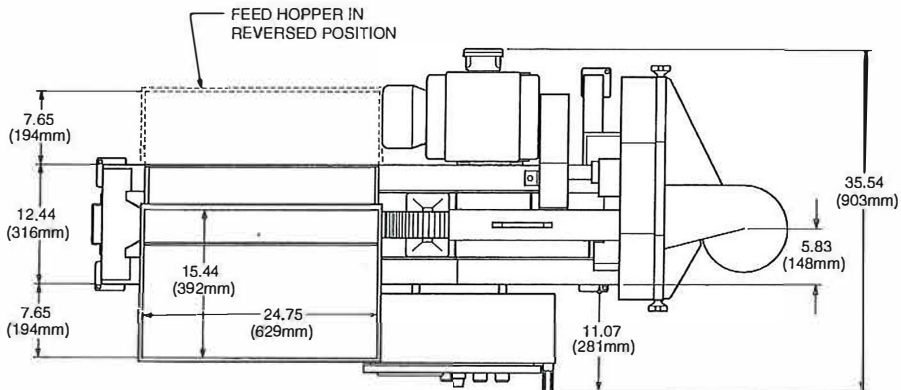
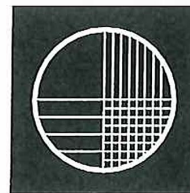

URSCHEL LABORATORIES INCORPORATED

2503 Calumet Avenue, P.O. Box 2200
Valparaiso, Indiana 46384-2200 U.S.A.
219/464-4811 Fax: 219/462-3879
<http://www.urschel.com>
E-mail: info@urschel.com

Designers and manufacturers of precision size reduction equipment.

©Urschel is a registered trademark of Urschel Laboratories, Inc.

Urschel® Model OV

Fast, Efficient Crosscut Slicer

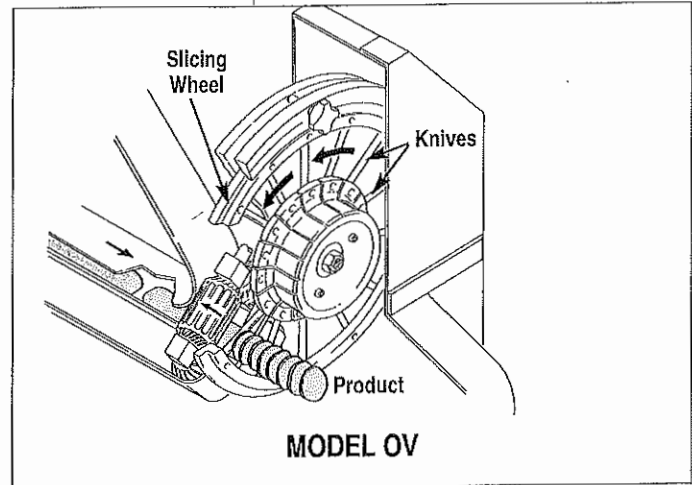
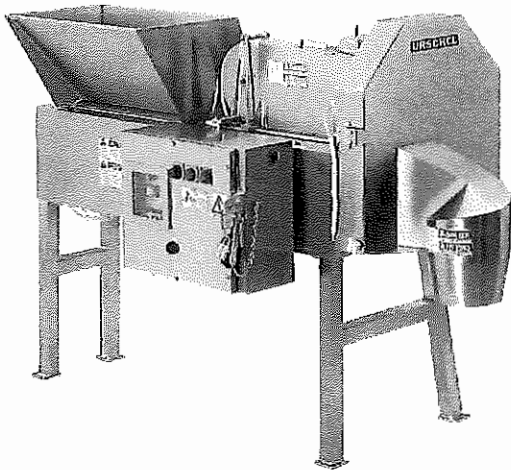

SPECIFICATIONS

Length: 72.92" (1852 mm)
 Width: 35.54" (903 mm)
 Height: 49.18" (1249 mm)
 Net Weight: 692 lb (314 kg)
 Motor: 3 HP (2.2 kW)

APPLICATIONS

The Urschel Model OV uniformly crosscut slices a wide variety of elongated food products at high capacities. Flat or crinkle style slices can be made from products such as carrots, celery, cucumbers, pickles, and squash. One slice is made at a time which prevents crushing of the products. The Model OV features a wide selection of slice thicknesses, continuous operation for uninterrupted production, and is designed for easy cleanup and maintenance. The Model OV accommodates products up to 2-3/4" (69.9 mm) in diameter or width.

OPERATING PRINCIPLE

Product delivered to a feed hopper feeds onto two high speed feed belts sloping together to form a "V" cross section. A free wheeling top belt completes enclosure of the product to insure positive feed into the rotating slicing wheel. Knives under tension serve as spokes and support the rim of the slicing wheel. The knives are slightly twisted to create a uniform pitch from the hub to the rim. Knife pitch serves to pull product through the slicing wheel and produce a precise slice thickness. One slice is made at a time which prevents any crushing of the product. The cut slices are then discharged into a spiral chute to reduce their speed before discharge from the machine.

TYPES OF CUTS

Flat & Crinkle Slices: A wide range from 1/16 to 1-3/4" (1.6 to 44.5 mm). When using crinkle knives, it is necessary to change the stainless steel shear edge.

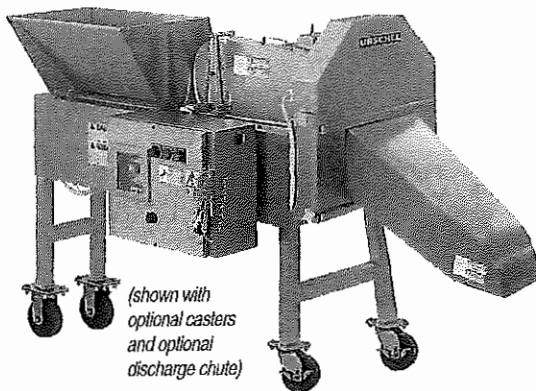

If your product application is not mentioned on this page, contact your local Urschel representative to determine the most effective solution to your size reduction needs.

@Urschel is a registered trademark of Urschel Laboratories, Inc.

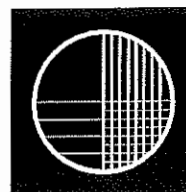

URSCHEL

LABORATORIES INCORPORATED

2503 Calumet Avenue, P.O. Box 2200
 Valparaiso, Indiana 46384-2200 U.S.A.
 219/464-4811 Fax: 219/462-3879
<http://www.urschel.com>
 E-mail: info@urschel.com

**Designers and manufacturers of
 precision size reduction equipment.**