

Bread slicers for professionals

FULL

Continuous slicing of all types of bread

High speed, thanks to motorised drive belts

Uncompromising robustness

Adjustable speed

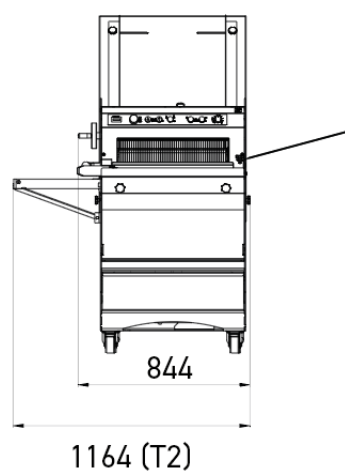
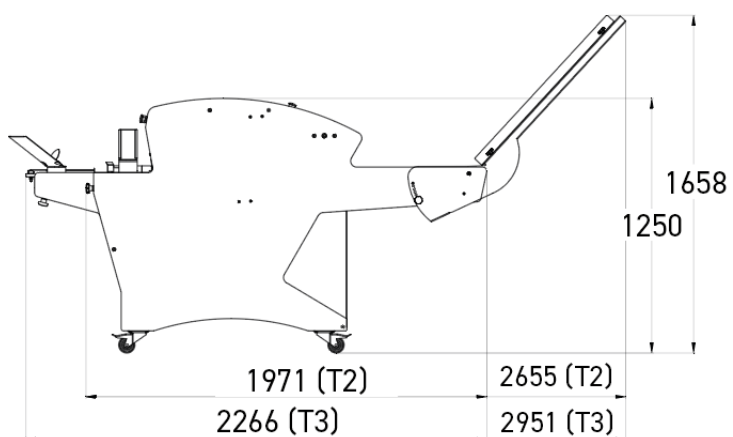

SPECIFICATIONS

Max. loaf dimensions in cm (W x H)	52 x 16
Motorised outfeed belt	•
Motor power in kW	1.1
Net weight (in kg)	365
Blade type and dimensions in mm	13 x 0.7 steel

TECHNICAL SPECIFICATIONS

Slice thickness in mm	11,12,13,14,15,16,17,18
Power supply	230V three-phase ,400V three-phase

MAIN STRENGTHS



Front control panel

Motorised adjustment of the upper belt height (height of loaves). Next to the front panel controls, a timer accurately records your working time.



Variable speed drive

Allows the cutting speed to be adjusted to suit the type of bread.



BPA-free paint

100% BPA-free satin paint (Bisphenol A): safer for you, gentler on the planet. Its low-temperature curing process significantly reduces energy consumption. Available in three solid colours: white, black or grey.



Rear loading belt

Provides uniform continuous cutting, thanks to adjustable side guides.



Motorised outfeed belt

Fitted with adjustable guides to ensure that the bread is held together after cutting.