

TOPTURN X55/X63

TURNER FOR TRIANGULAR WINDROWS
PERFECT MIXING
WHEEL OR TRACK
ON TOP OF THE SITUATION
MAINTENANCE MADE EASY





HIGHLIGHTS



- » Large-dimensioned turning drum for high throughput and complete mixing
- » Wheel drive or Track drive
- » Comfortable cabin with more space and new intuitive controls
- » Easy maintenance access with ladders and platforms integrated in the body
- » Wide application area: Composting of MSW, green waste, biowaste, sewage sludge, treatment of contaminated soils, mixing of ores



TOPTURN X55/63 IN OPERATION

The Topturn is one of the most widely used compost turners in the world. With the new X55 and X63 we are further extending our position. Inspired by our customers, this third generation of the Topturn offers top performance with complete comfort and convenience. An even sturdier telescopic frame, high performance hydraulics and generously dimensioned turning drum mean high throughput in all working scenarios.

The engine meets the latest emissions standards, and the new cooling system keeps everything cool even under heavy loads and high outside temperatures. Further plus points are the larger, comfortable cabin and new automatic drive for relaxed working, and the hydraulically extendible maintenance platforms for fast, easy maintenance.

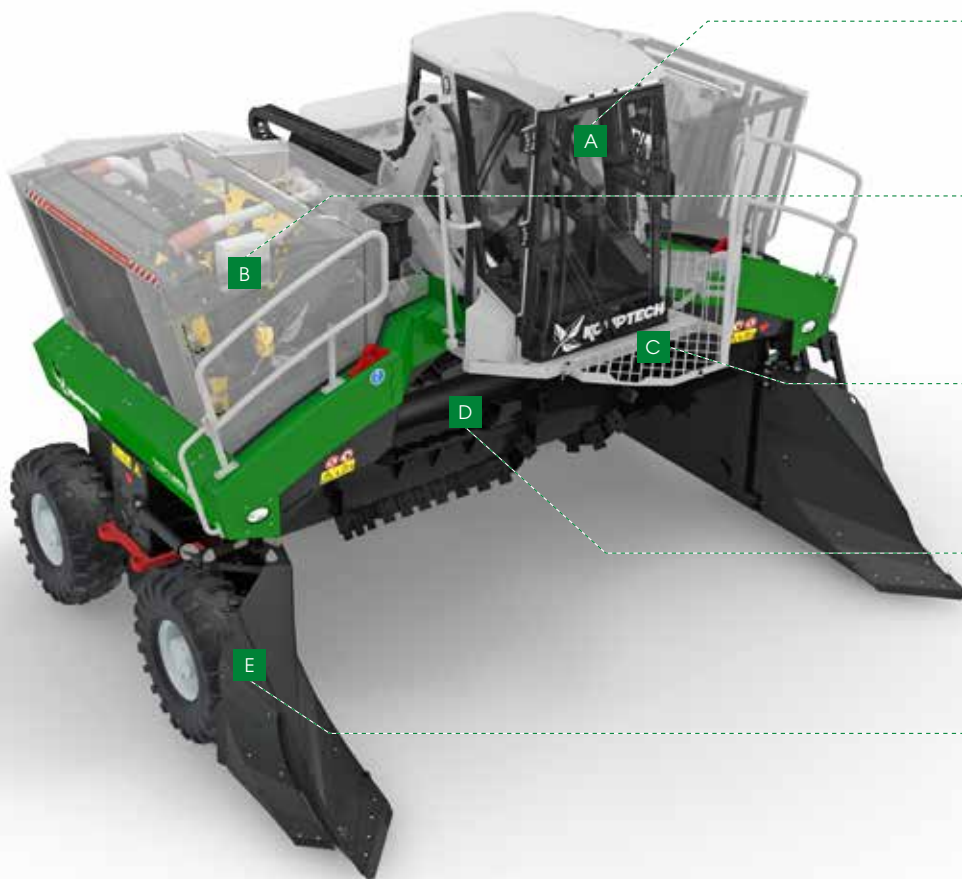

A
Spacious comfortable cabin
(optional with lift function)

B
Powerful diesel engine with
newest emission stage

C
Service steps and platform
simplify maintenance

D
Turning drum
with large diameter

E
Robust
plough blades



01

Wheel or track

The wheeled chassis has impressive benefits on asphalt and concrete. Power is delivered to all wheels, providing high traction and quick maneuverability. Combined with the comfortable ride provided by tires, these are persuasive arguments. The tracked chassis is the ideal option for unpaved ground. Engine power is converted effectively into forward movement and the open track design enables simple cleaning.



02

On top of the situation

Work made easier - the new cabin is a comfortable workspace, with more room, powerful air conditioner and air-cushioned seat. The new information system can be intuitively operated using a large colour display, so the machine can be adapted to any working conditions.



03

Maintenance made easy

A press of a button turns the left and right body panels into roomy maintenance platforms with convenient access steps so the operator can reach all maintenance points safely and easily. The drum blades have a very long service life, after which they are easy and inexpensive to change.

Topturn X55

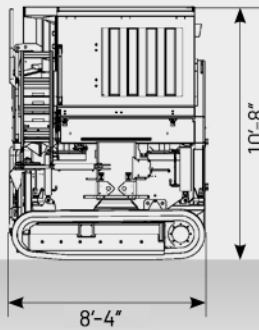

Track transport dimensions

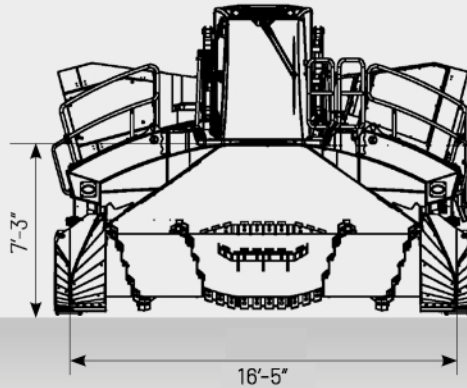

Working position

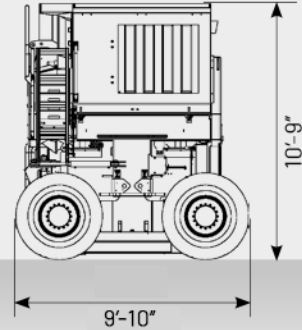

Wheel transport dimensions

TOPTURN X55

TOPTURN X63

	TOPTURN X55	TOPTURN X63
Drive		
Diesel engine:	CAT @ C9.3 Tier 4 Final/Stage IV or Tier 3/Stage IIIA	CAT @ C13 Tier 4 Final/Stage IV or Tier 3/Stage IIIA
Power (kW / HP):	242 / 330	287 / 390
Turning device		
Drum diameter (ft):	3'-11"	4'-7"
Drum rpm:	0-195	0-195
Windrow dimensions		
Windrow width (ft):	16'-5"	18'-8"
Max. windrow height (ft):	7'-3"	8'-6"
Windrow cross-section at 45° repose angle (yd ²)	7.4 yd ²	9.7 yd ²
Travelling speeds (I standard, II optional)		
Wheel (km/h):	I: 0-4 II: 0-6	I: 0-4 II: 0-6
Track (km/h):	I: 0-4	I: 0-4
Dimensions L x W x H		
Transport dimensions Wheel (ft):	17'-11" x 9'-10" x 10'-9"	20'-2" x 9'-10" x 11'-11"
Transport dimensions Track (ft):	7'-11" x 8'-4" x 10'-8"	20'-2" x 8'-4" x 11'-10"
Working dimensions Wheel (ft):	13'-0" x 17'-4" x 14'-6"	14'-1" x 20'-0" x 15'-10"
Working dimensions Track (ft):	13'-0" x 17'-5" x 14'-4"	13'-0" x 19'-8" x 15'-8"
Weight		
Wheel (lbs):	35,274 lbs	39,683 lbs
Track (lbs):	36,376 lbs	41,226 lbs
Throughput (dependent on material)		
Throughput performance (m ³ /h):	up to 4000	up to 4500
Options		

Mixing drum (X55), two speed levels, lateral displacement device, central lubrication, scraper, protective ventilation, watering etc.



Komptech GmbH
 Kühau 37, 8130 Frohnleiten, Austria
 [t] +43 3126 505 - 0
 [f] +43 3126 505 - 505
 [e] info@komptech.com

www.komptech.com

We reserve the right to make technical changes in the course of ongoing development. E2016