

M&J Mobile Pre-shredders



Superior
Recycling
Technology

Move, shred and repeat with M&J mobile pre-shredders

With M&J's mobile pre-shredders, it's easier than ever before to process all kinds of waste in almost any location, including transfer stations, landfills, and material recovery facilities. Designed to meet the special needs of plants with incoming material that varies greatly in size and composition, our mobile pre-shredders are the future-proof choice.

It features all the robustness and strength you'd expect from an M&J pre-shredder, with the benefits of being easier to operate, more efficient to run and easier to service, all of which help to reduce running costs. Operators will experience a boost in capacity and can trust there will be no unscheduled downtime.



Can handle any waste type, among others:

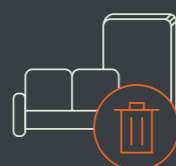

Bulky waste



Municipal solid waste



Commercial & industrial waste



Construction & demolition waste



Plastic waste



Paper & cardboard



Post-consumer plastic bag opening



Waste wood & wood stumps



RDF/SRF



Testimonial

"During a demo with the M&J 4000M, a 16x80 ft. mobile home with four axles was fed to the shredder. It literally ate it like a cookie. It was very, very impressive... no competing mobile shredders compared to M&J"

Charles Hartsell
Chief Operating Officer, Rockwood Sustainable Solutions

Key benefits:

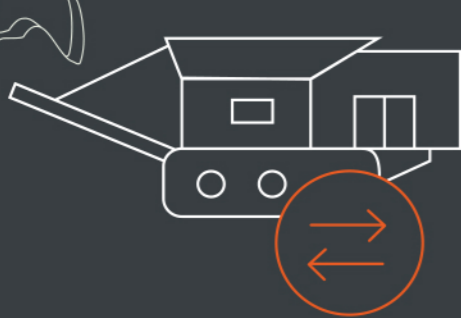

Versatility on the move:

M&J mobile pre-shredders deliver reliable performance across various applications—all while on the move. You get a truly universal shredder ideal for landfills, rentals, and more.



Tackle the toughest waste:

Tested to tackle the toughest shredding jobs, thanks to aggressive, hard-steel knives welded onto the shaft and an open cutting table for debris to fall through.

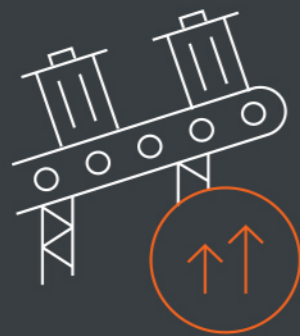

Improve your productivity:

The twin-shaft, asynchronous cutting system reduces bridging and ensures consistent output, while an anti-jam system keeps operations running smoothly even on tough waste.



Operate trouble-free:

Smart design minimises unplanned repairs and stops, lowering operational costs. Access real-time performance data via myM&J Performance and control the shredder remotely for safe, efficient handling, even while operating

M&J Mobile Pre-shredder Product Range

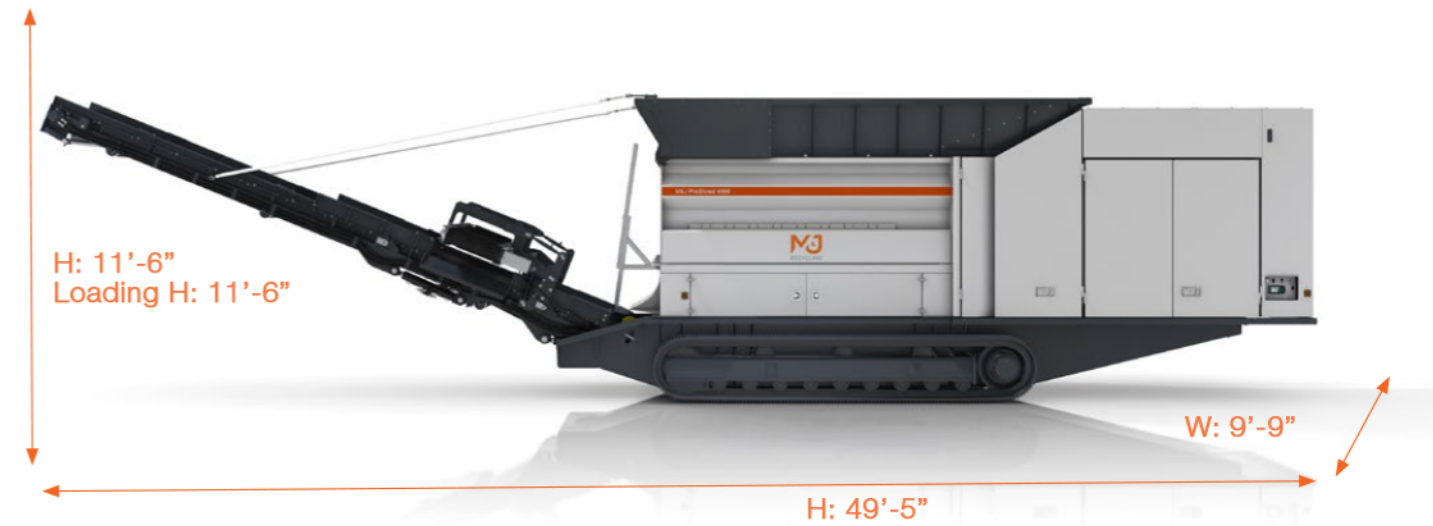

M&J 4000M pre-shredder (crawlers)

Power: 403 kW.
Capacity: Up to 100 t/h*.
Knife count: 6, 8, 9, 10, 12



M&J 3000M pre-shredder (crawlers)

Power: 403 kW.
Capacity: Up to 60 t/h*.
Knife count: 7, 8, 9, 11



M&J Mobile Pre-shredder Built to move, engineered to perform

Your most versatile, robust and reliable mobile pre-shredder, based on the original M&J cutting technology, developed by our expert engineers.

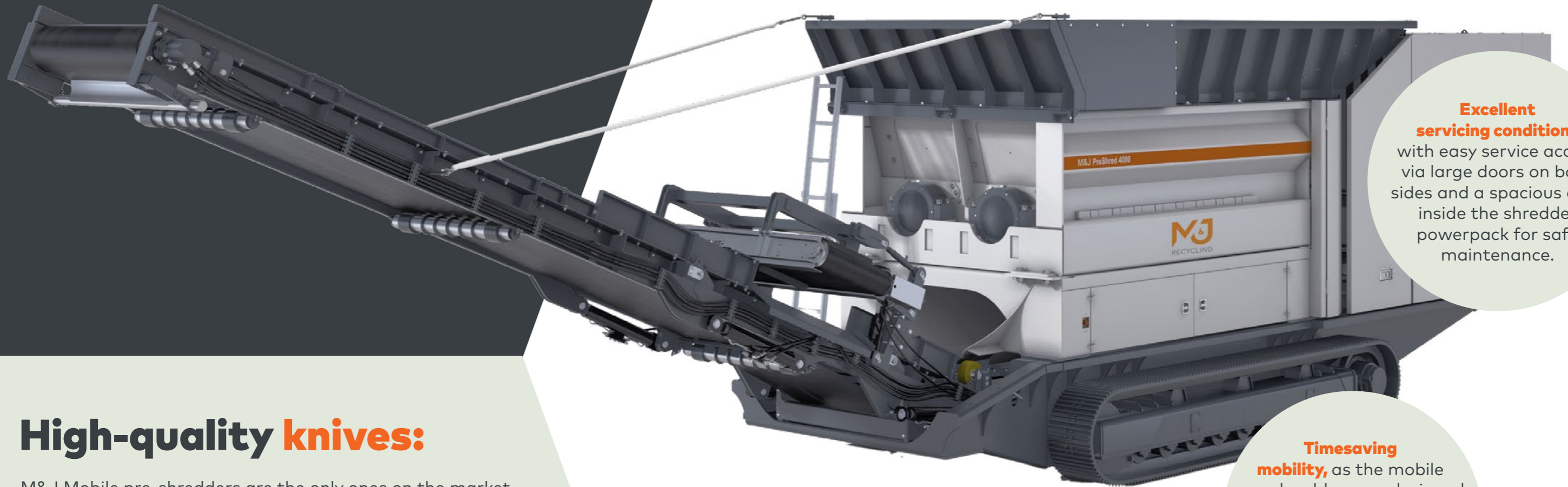

Customisable cutting table & knives

for easy adaptation to different types of materials and output requirements.

Intuitive touchscreen & 6 program options to optimise the capacity according to the material type.

Excellent servicing conditions

with easy service access via large doors on both sides and a spacious area inside the shredder powerpack for safe maintenance.

High-quality knives:

M&J Mobile pre-shredders are the only ones on the market that can be equipped with 6 knives and up to 12 knives per shaft.

Because knife performance is critical, we use an advanced automated welding robot to ensure exceptional and consistent quality. The heating process for shafts and knives is monitored and logged 100%, guaranteeing the correct temperature before welding. The robot also positions and mounts each knife with precise accuracy within the specified tolerances—delivering superior quality and outstanding reliability in the final product.

Trusted equipment quality with features such as premium conveyors, robust over-band magnets, and components forged from special hard steel – giving you a shredder that never quits.

Timesaving mobility, as the mobile pre-shredders are designed to be on the move even when operating. This means no lost production hours when moving between waste piles.

Transfer Station case: From waste to wins

In the waste management industry, the cost of inefficiency often hides in plain sight — or rather, in the air between loosely packed materials. For transfer stations, this hidden problem translates into higher transportation costs, landfills filling up faster, and a larger environmental footprint.

One solution? Shredding waste directly on-site at the transfer station before it's transported to the landfill. But doing so places heavy demands on the shredder's mobility, durability, and versatility.

Case form USA: shredder built to move waste — and numbers

With an M&J mobile pre-shredder in place, transfer stations can boost waste density from roughly 400 to 600 pounds per cubic yard. This can reduce daily landfill use by nearly 700 cubic yards and extend landfill life by more than six years.

Likewise, railcar payloads increase from 60 to 75 tons — a 25% improvement. For one operator, that meant eliminating over 300 railcars per year, saving approximately \$1.95 million annually.

Make life better; cut your costs and carbon footprint while boosting your efficiency with an M&J mobile pre-shredder.



More than a shredder - peace of mind for a lifetime

Our global network of highly skilled Service Technicians is always close at hand, ready to provide the support you need, whether remotely or on-site. With key spare parts always nearby, we keep your operations running smoothly.

Our **Training Academy** ensures every technician is highly skilled and up to date, delivering top-quality service every time. We also offer customised training to empower your team and improve your daily performance.

|| Many of our shredders still perform at peak level after 25–30 years – a testament not only to their robustness but also to our high-quality service.

Michael Stampe
Head of Service Operation,
M&J Recycling

Our support doesn't end after delivery

To keep your production performing at its best, we continuously develop solutions that will optimise your shredder – new as old:

Remote monitoring

myM&J Performance is a digital monitor for your shredder, delivering key insights into its condition, performance, and maintenance needs.

Timely maintenance is essential for optimal, cost-efficient production.

That's why we offer service maintenance agreements for all our shredders, delivered either by us or one of our trusted partners. With proactive, ongoing maintenance, your shredder will run at peak performance—and stay reliable for the next 20, 25, even 30 years.

M&J Denmark A/S

Vejlevej 5, 8700 Horsens,
Denmark

Phone: +45 7626 6400

Mail: sales@mjrecycling.com

www: mjrecycling.com

M&J Germany GmbH

Köpenicker Chaussee 3A,
10317 Berlin.

Phone: +49 (0)173 6252829

M&J Recycling United Kingdom

823 Salisbury House, 29 Finsbury Circus,
London, EC2M 5QQ

Phone: +44 07341 885 55

M&J USA Inc.

2015 Ayrley Town Boulevard, Suite 202
Charlotte North Carolina 28273

Phone: +1 704 589 3113

M&J Recycling South Korea

4th Floor LS Yongsan Tower, Hangangdaero 92, Yongsan-gu,
Seoul, 4386, South Korea

Phone: +82 10 6416 6763

M&J Recycling Thailand

571 RSU Tower, 9th floor, Unit 9017, Sukhumvit Soi 31, Sukhumvit Road,
Klongton-Nua, Wattana, Bangkok 10110, Thailand

Phone: +66 89 499 1922

M&J Recycling India Private Limited

Unit No 305 and 306, 3rd floor, Atrium II, J.B Nagar, MIDC,
Chakala, Andheri (E), Mumbai 400 093, India

Phone: +91 9677912403

The information in this document is provided for guidance only and as is without warranty of any kind, either express or implied, including but not limited to the implied warranties of merchantability, fitness for a particular purpose or non-infringement. Information in this document may include information not appropriate to specific configurations, or information which has not been updated. M&J Recycling has the right to make changes in the document without notice. Not all products or services are available in all countries. In no event shall M&J Recycling be liable for any damages.
M&J Recycling, 18/12/2025



Superior
Recycling
Technology