

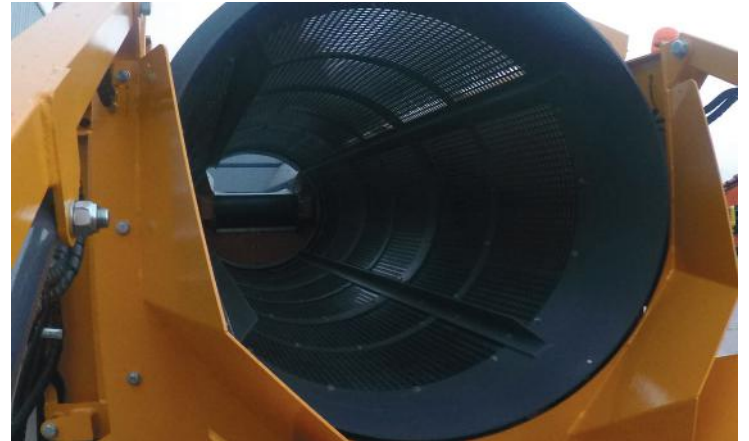

Barford T516 Tracked Trommel



5'x16' Drum, Variable Screening Angle, Hopper Capacity: 3.8M³, Feeder Belt Width 950mm, Side Conveyor Belt Width 650mm, Transfer Conveyor Belt Width 1050mm, Oversize Conveyor Belt Width 950mm, Chevron Belt, Power Unit: CAT 4.4 74KW Engine, Tracks: 2.9M Tracks * 300mm Shoes, Remote Control Movement



Barford T516 Tracked Trommel

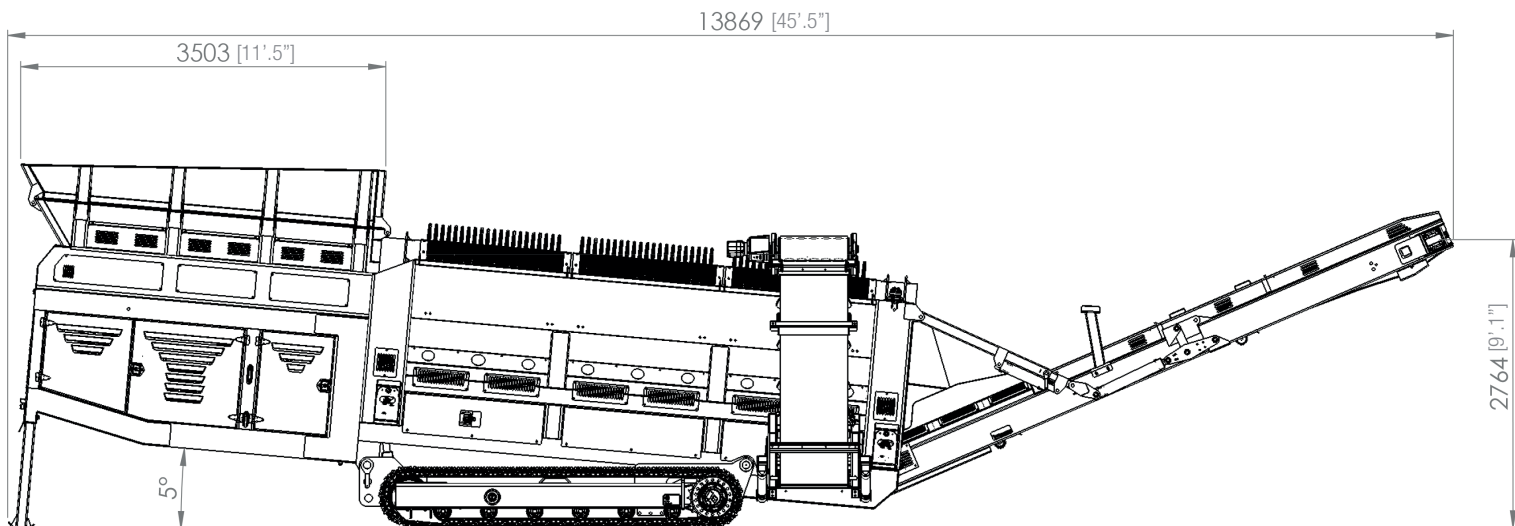
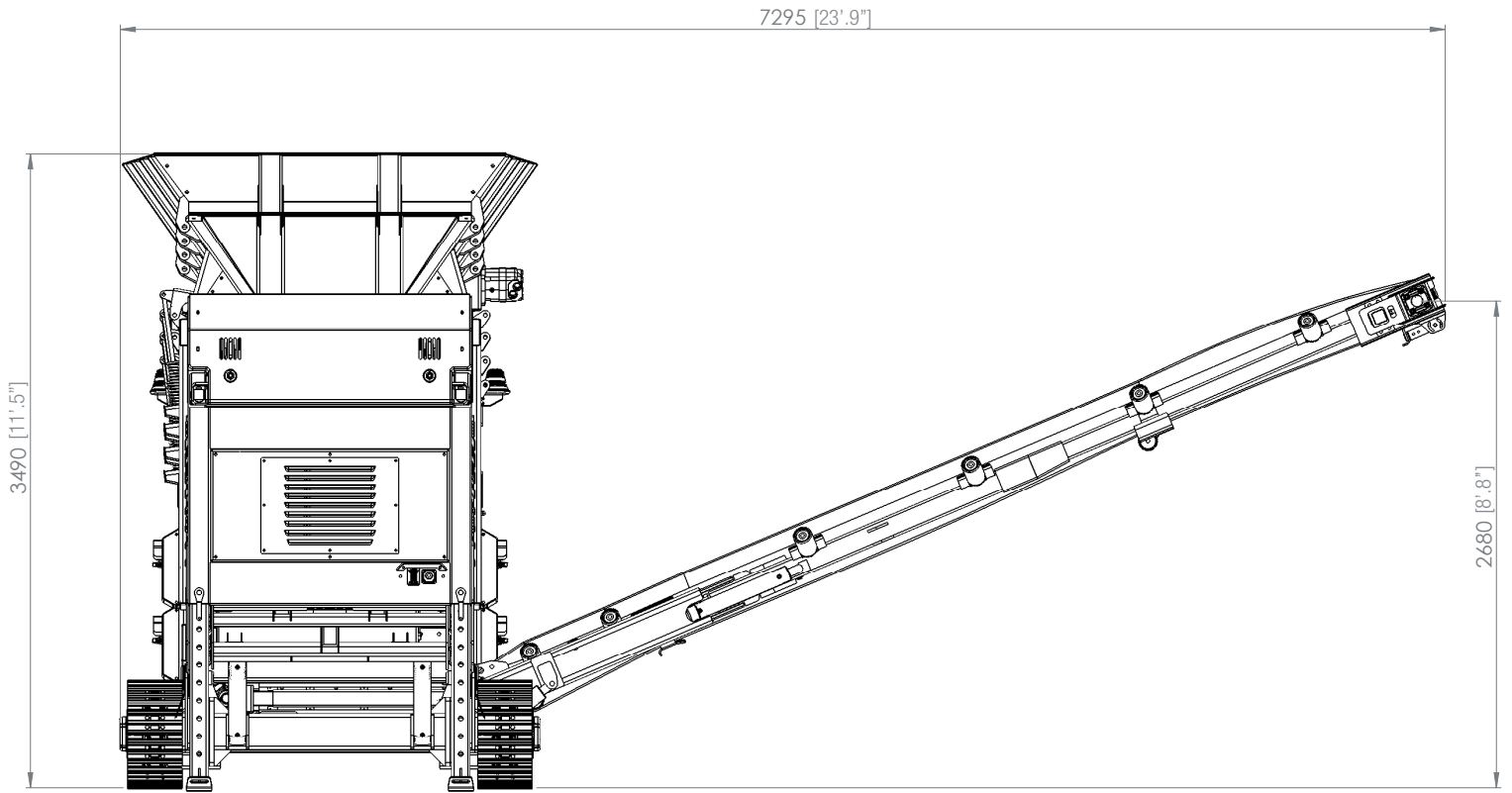



Barford T512 Tracked Stockpile Conveyor



5'x13' Long Direct Drive Drum, Variable Speed Feeder and Drum, Adjustable Brush Tensioners, Hopper Capacity 3.5M3 (4.6Cubic Yards), Feeder Belt Width 900mm, Fines Conveyor Belt Width 900mm, Stockpile Conveyor Belt Width 750mm, Chevron Belt, CAT 2.2 4