



KOMPTECH

TECHNOLOGY FOR A BETTER ENVIRONMENT

STONEFEX 3000 E

STONE SEPARATOR
BROAD RANGE OF APPLICATIONS
EFFICIENT SEPARATING SYSTEM
RELIABLE OPERATION
MOBILE AND ECONOMICAL





HIGHLIGHTS



- » Dependable removal of up to 95 percent of stones and inert items (depending on input material)
- » Throughput up to 100 m³/h with configuration for input particle size of 10...20–100 mm
- » Wide range of application due to simple modification of separation limits
- » Low energy costs due to electrical drive of all components
- » Compatible with almost all mobile screening machines



STONEFEX

STONE SEPARATOR

The Stonefex 3000 E stone separator reliably and very effectively removes stones and inert items from biomass fuels. The input material is the usable biofuel fraction from a screener, for example woody green cuttings, screen residue from compost, or forestry chips. A patented system of pressure and suction blowers generates exactly the

right air flow in the separation chamber to remove stones and heavy objects from the wood.

Fractions that were previously difficult to use due to their high amount of stones can now be processed into fuel. Biomass processors profit from better customer demand for their fuels and higher sale prices.



A
Intake conveyor with adjustable speed

B
Pressure blower with frequency control

C
Discharge conveyor for stone fraction

D
Suction blower with discharge pipe for fibres

E
Discharge conveyor for usable fraction

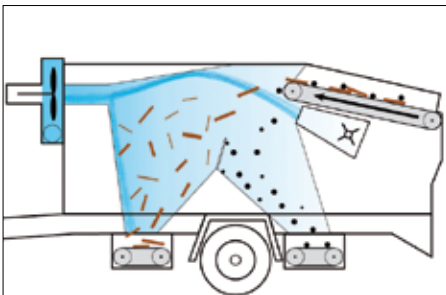

Wood fraction Stone fraction

01

Efficient separating system

The input material is loaded onto the intake conveyor. In the expansion chamber, a system of pressure and suction blowers separates the material into a stone fraction and a cleaned usable fraction, which conveyors take out to opposite sides. Fibrous materials are collected in the container downstream of the suction blower.



02

Reliable functioning and simple maintenance

Thanks to easy adjustment of the intake conveyor speed, blower speed and separating vertex, the Stonefex keeps working efficiently even with variable feedstocks. Large access panels to the separation chamber and the motor compartment and the swivelling suction blower make for simple and convenient maintenance.



03

Mobile and economical

The single-axle trailer configuration makes the machine easy to manoeuvre, and it is approved for 80 km/h road speeds, so transportation to the site is no problem. The standard version uses grid electrical power. As an option, a diesel generator is available. The resulting hybrid drive system ensures low energy and maintenance costs.

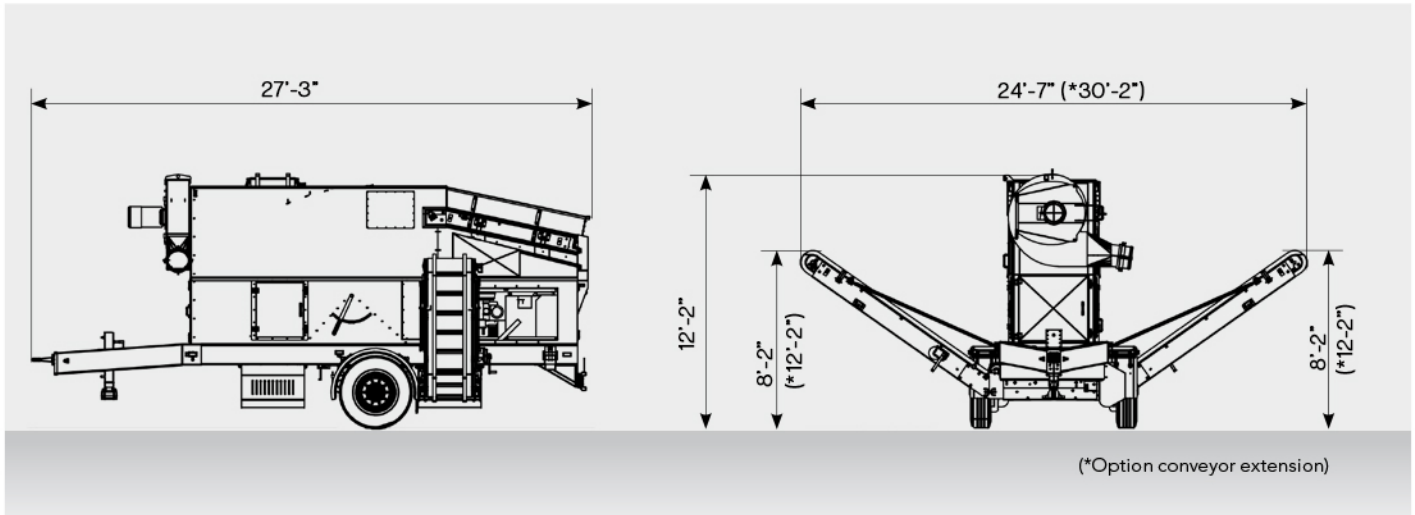

STONEFEX 3000 E

Drive	
Electrical power input (kW):	26
Diesel generator (kVA):	30 (constant)
Material feeding - Intake conveyor	
Filling width	3'-11"
Filling height	10'-4"
Drive (kW):	3,0
Blower drive	
Pressure blower (kW):	7,5
Suction- and feed blower (kW):	11
Discharge - Stone fraction	
Design:	Corrugated edge belt
Discharge height	8'-2" (option 12'-2")
Discharge - Wood fraction	
Design:	Corrugated edge belt
Discharge height	8'-2" (option 12'-2")
Dimensions	
Transport dimensions L x W x H	27'-3" x 8'-4" x 13'-1"
Working dimensions L x W x H	27'-3" x 24'-7" x 12'-2"
Weight	19,850 lbs
Throughput (dependent on material)	
Throughput performance (m ³ /h):	up to 100
Options	

Conveyor extension, adjustable belt speed, foldable electro-hydraulic discharge belts, diesel generator, Cleanfix fan, central lubrication, frequency converter for suction blower, remote control, increased sidebars for intake conveyor and more



Komptech GmbH
 Kühau 37, A-8130 Frohnleiten
 [t] +43 3126 505-0
 [f] +43 3126 505-505
 [e] info@komptech.com

Komptech UK Ltd.
 Forge End, Lodge Farm Kineton
 Warwickshire, CV35 0JH
 [t] +44 1926 64 29 72
 [f] +44 1926 64 29 71
 [e] info.uk@komptech.com

www.komptech.com

We reserve the right to make technical changes due to ongoing development. E2012