

MPK20.2

2IN1 MINIPICKER:
PICK&CARRY CRANE & GLASS ROBOT



Lifting capacity

2000 kg



Max tip height

7,4 m



Dimensions (l x w x h)

2690 x 1190 x 1530 mm



Powered by

Li-ion battery



Weight

1845 kg

1440 kg machine
405 kg removable ballast



EN [m - kg]



WORKING MODES

WINCH

2000 kg

- Two options: 700kg-62 m / 600kg-135 m
- Up to 2000 kg / 1800 kg capacity 3 falls



Winch Load Chart

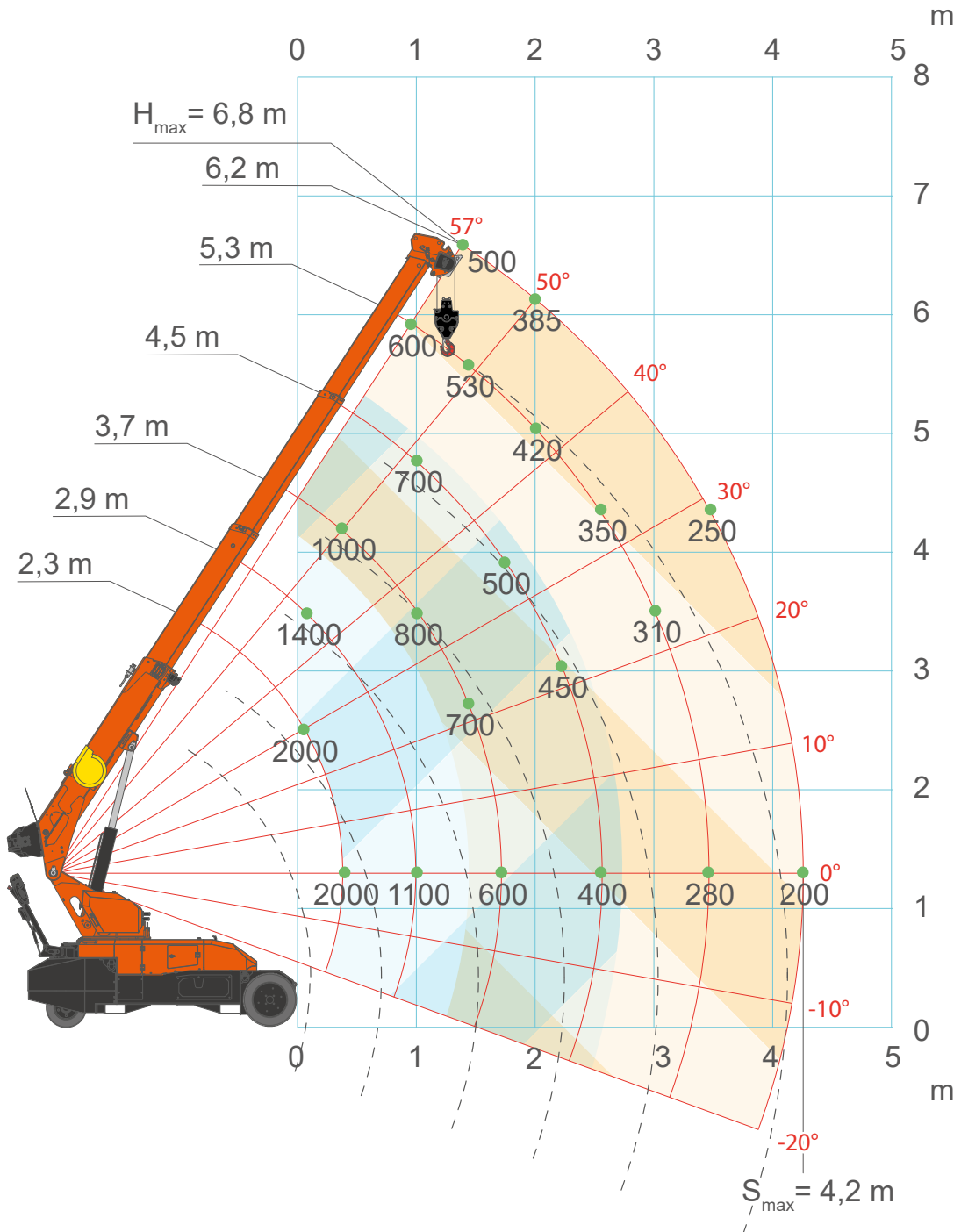

SEARCHER HOOK

1000 kg

JVM800R MANIPULATOR **800 kg**

- 4 angles: +25° / +10° / -20° / -45°
- Increases working geometry and versatility
- Easily stowed on the crane when not in use

- Stand-alone vacuum manipulator for glass and panels
- Independent vacuum system, battery, radio remote control
- Universal for any crane
- Up to 8 pads, modular layout
- Two independent vacuum circuits
- 360° rotation, tilt and swing
- Pads for glass, marble, slabs and sandwich panels
- "Blow-off" function for easy release



*More info on JVM800R brochure

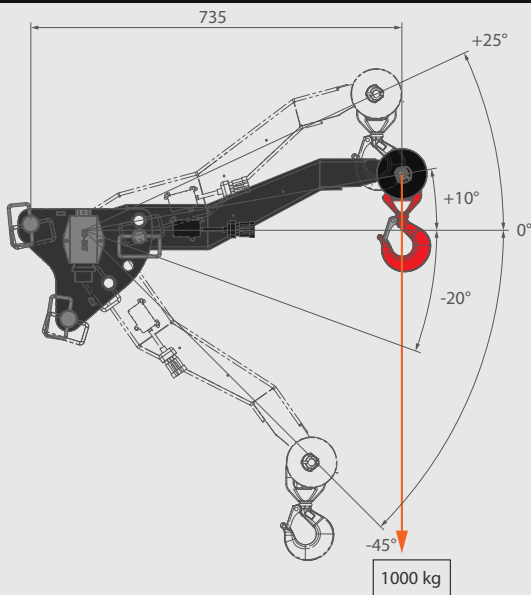

HOOK

2000 kg

- Unique drop-down design
- Fast hook-winch switch



Searcher Hook Load Chart

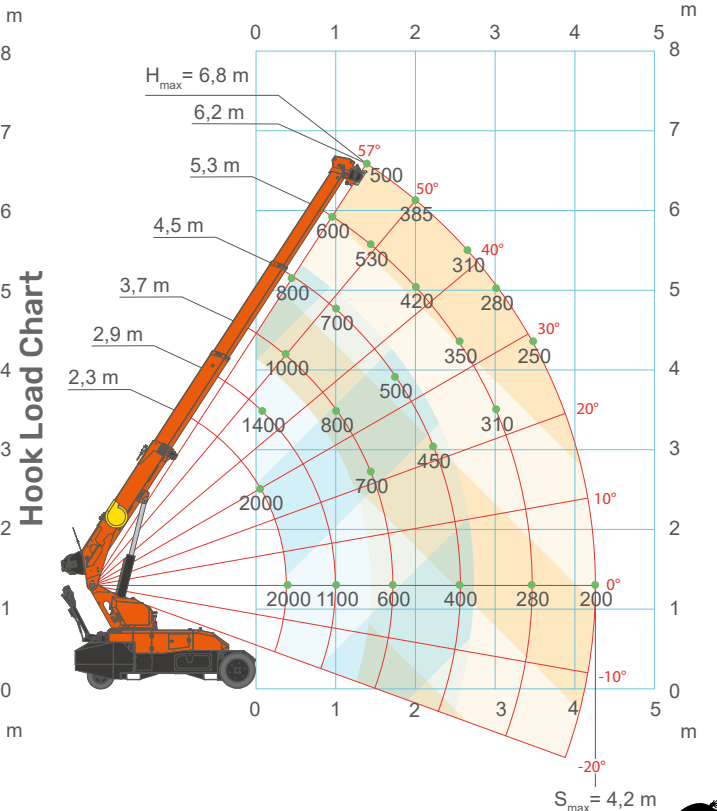
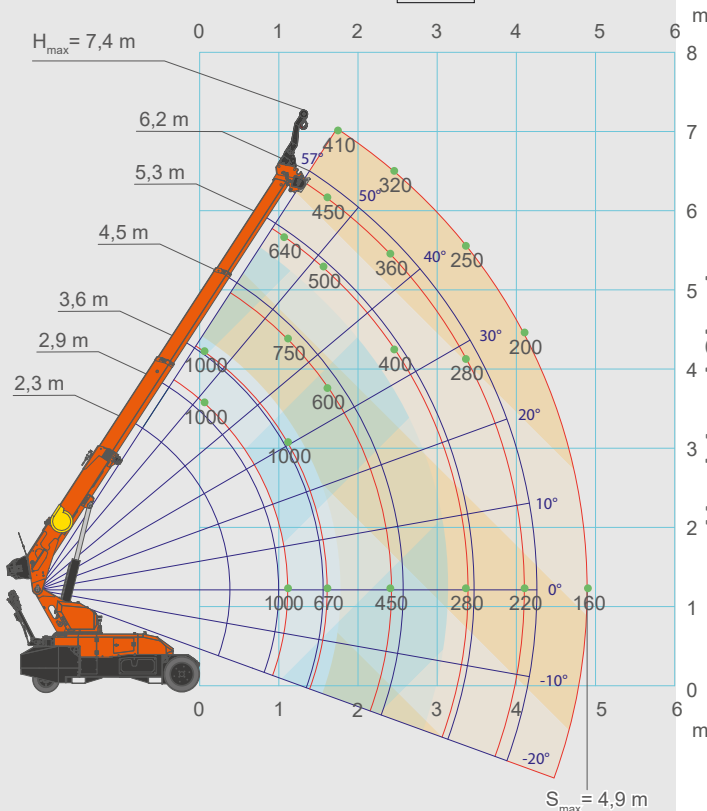



INTUITIVE CONTROL

Onboard display:

- 5" IP66 touch display for management & diagnostics

Radio remote control*: Simple, intuitive, proportional

- Spare battery on board
- Self-diagnostics & emergency button

Tiller bar: all driving and crane functions available

EASY TO DRIVE EVERYWHERE

- Steer by wire *
- Front-wheel drive with two independent motors
- Twin front and rear wheels

BOOM MOBILITY

- Turret side rotation $\pm 6^\circ$
- Double hydraulic + 1 manual boom extensions



LI-ION BATTERY POWERED

- Indoor operation, emission free
- Maintenance free
- Runtime over 1 workday
- On board 110/230V fast charger: 0-80% in 3 h
- Adjustable charging current
- Work while charging



MODULAR BALLAST

- Easily removable ballast modules
- Operates without ballast
- Automatic lifting capacity adjustment
- 405 kg total weight



INDOOR WHEELS

- Non-marking white tyres for indoor



J-LINK POWERED BY TRACKUNIT*

- Remote fleet monitoring and diagnostics
- Built-in or retrofit on existing units

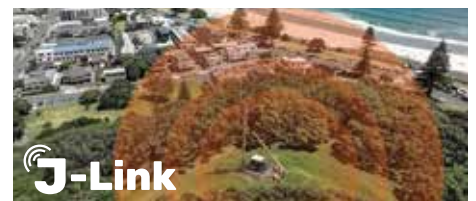

*Optional



MPK20.2
2IN1 MINIPICKER



Barcelona
938498388

Madrid
918951758

Valencia
961344394

Vitoria
945365601

www.transgruas.com
info@transgruas.com