

MPK10.2



2IN1 MINIPICKER:
GLASS ROBOT & PICK&CARRY CRANE



Lifting capacity

990 kg



Max tip height

5,2 m



Dimensions (l x w x h)

2280 x 955 x 1500 mm



Powered by
Battery



Weight

1275 kg

1045 kg machine
230 kg removable ballast



EN [m - kg]



WORKING MODES



VACUUM MANIPULATOR **990 kg**

- Up to 10 pads, modular layout
- Electrically operated via wired control or radio control
- Vacuum pump on-board
- Two independent vacuum circuits
- 360° rotation, tilt and swing
- Ø400 or Ø290 pads for glass, marble and slabs
- Special pads for monopanel
- "Blow-off" function for easy release
- Ball joint on pads for improved adaptability

ENDLESS PADS CONFIGURATIONS

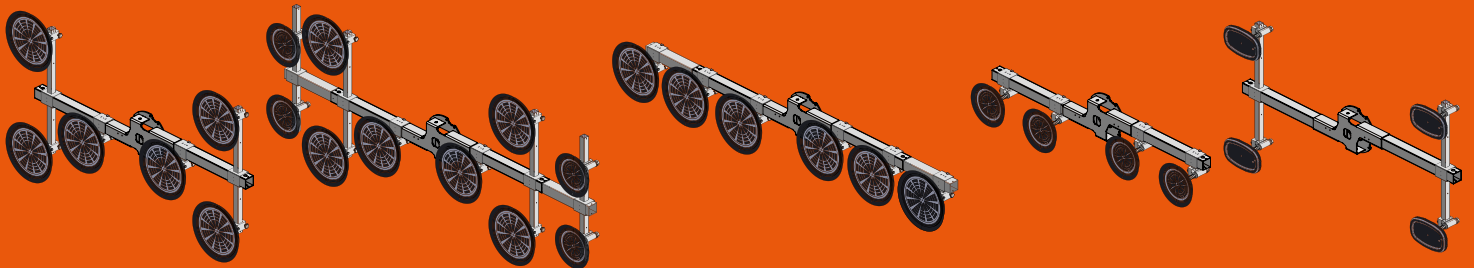

Standard

10 pads - Ø400 & Ø290

Ø400 in-line

Ø290 in-line

Monopanel

and more...

Manipulator Load Chart

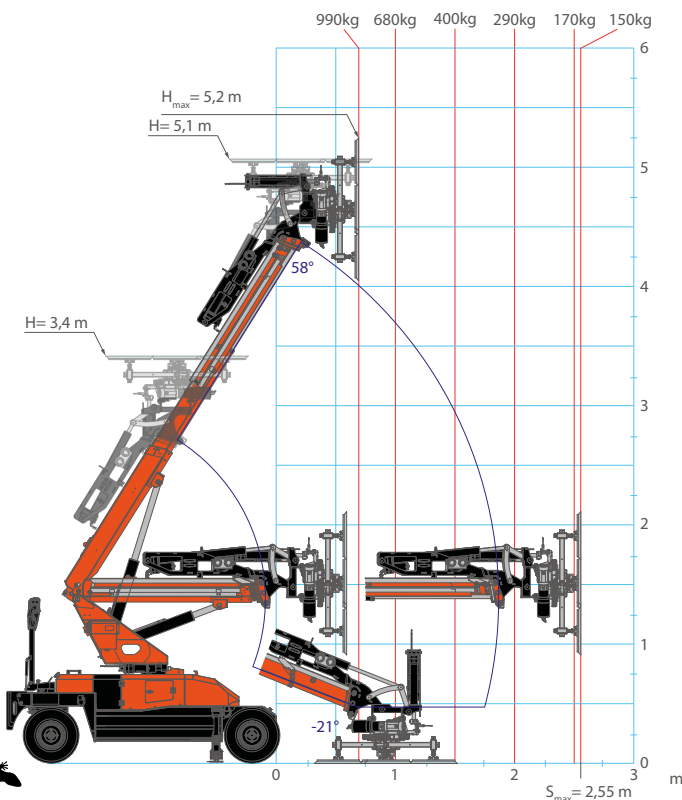

+47/-96 Tilt

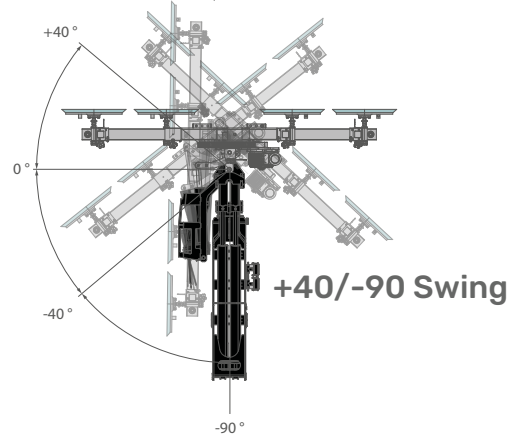
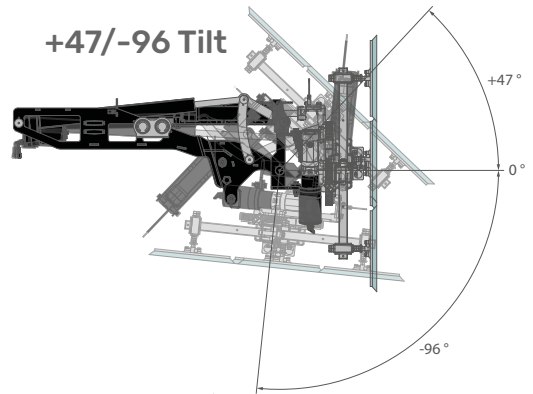

SEARCHER HOOK

990 kg

- 4 angles: +15° / 0° / -30° / -60°
- Increases versatility
- Stowed onboard



MANIPULATOR HOOK

600 kg

- Quickly installed on manipulator frame
- Electrical tilt and swing

HOOK

990 kg

- 600 kg

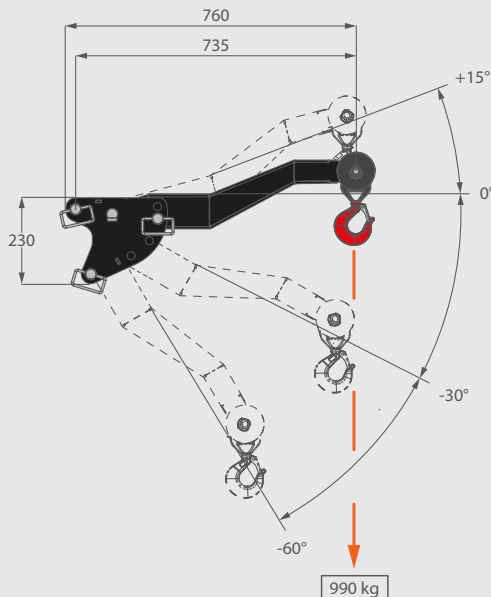

Searcher Hook Load Chart

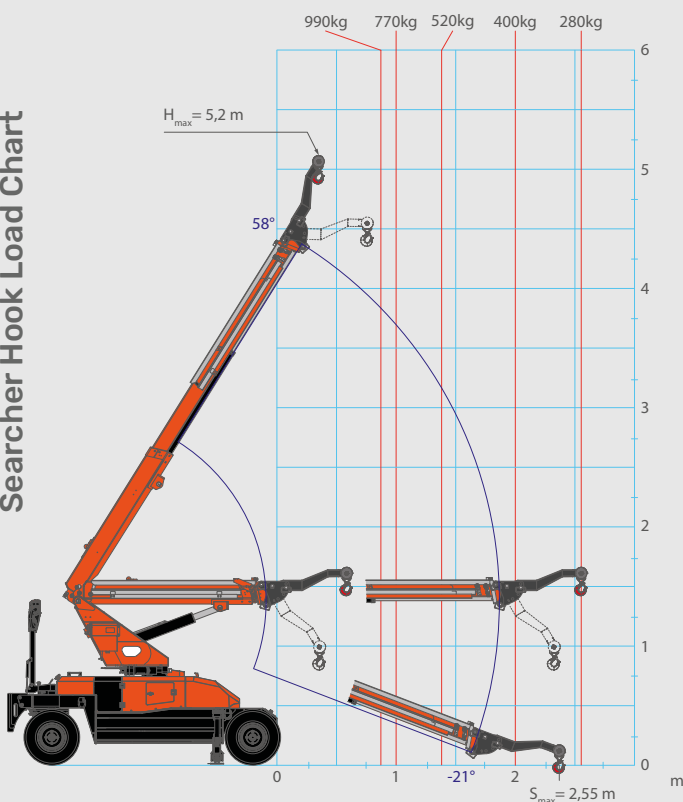

Manipulator Hook Load Chart

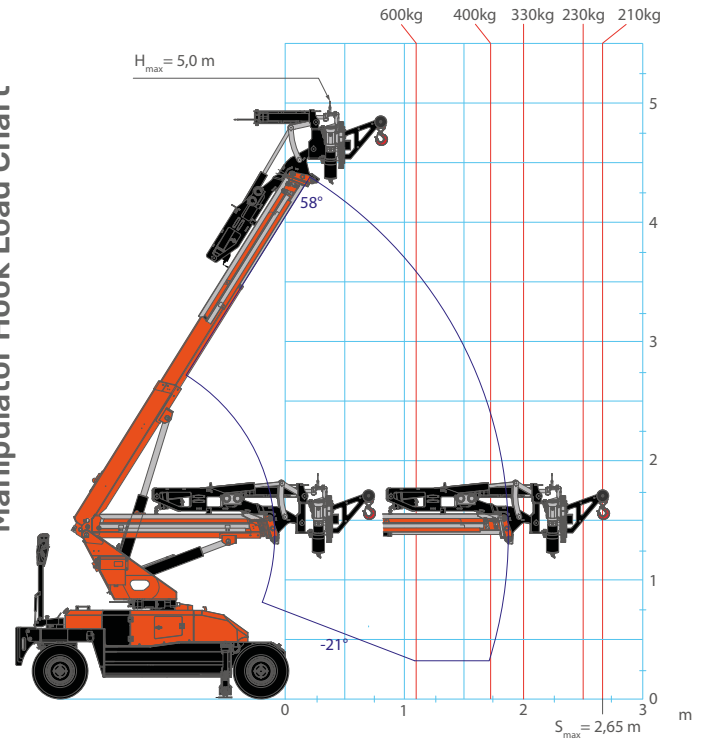

Hook Load Chart

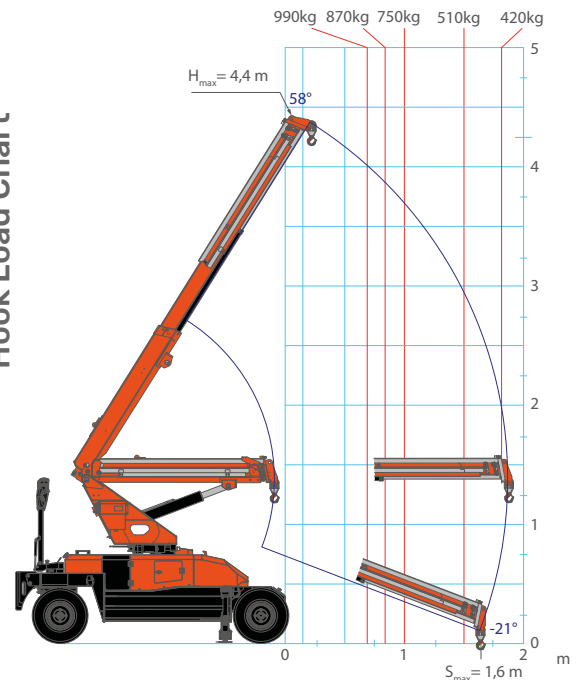



RADIO REMOTE CONTROL * BOOM MOBILITY

- Controls machine driving, crane and manipulator
- Simple and intuitive, proportional
- Spare battery on board
- Wired control also available
- Self-diagnostics & emergency button

- Turret side rotation $\pm 9^\circ$
- -21° to $+58^\circ$ boom angle
- Double hydraulic boom extensions

FULLY ELECTRIC

- Battery powered, Lead-acid type 24 V 310 Ah
- Minimal maintenance costs
- Emission-free indoor operation
- On board 110V or 230V fast battery charger
- Runtime over 1 workday



MODULAR BALLAST

- Easily removable ballast modules
- Operates with reduced ballast
- Automatic lifting capacity adjustment
- 230 kg total weight



EASY TO DRIVE EVERYWHERE

- Front-wheel drive with differential
- Wide steering angle
- Side stabilisers
- Twin front wheels available *



OUTDOOR-INDOOR WHEELS

- Off-road tyres (foamed puncture-proof)
- Non-marking white tyres for indoor *



J-LINK POWERED BY TRACKUNIT*

- Remote fleet monitoring and diagnostics
- Built-in or retrofit on existing units



*Optional



MPK10.2
2IN1 MINIPICKER



Barcelona
938498388
Valencia
961344394

Madrid
918951758
Vitoria
945365601

www.transgruas.com
info@transgruas.com