

MPK06.2



2IN1 MINIPICKER:
GLASS ROBOT & PICK&CARRY CRANE



Lifting capacity

600 kg



Max tip height

4,2 m



Dimensions (L x W x H)

L x W x H

1840 x 730 x 1450 mm



Powered by
Battery



Weight

915 kg

724 kg machine
191 kg removable ballast



EN [m - kg]



WORKING MODES

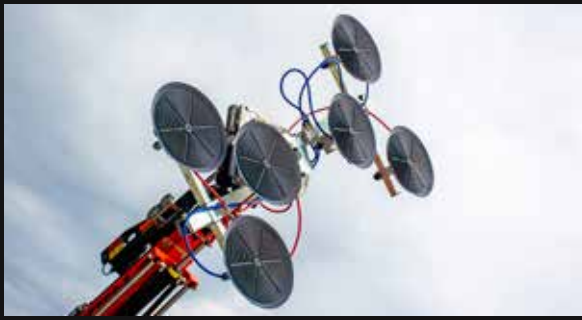

VACUUM MANIPULATOR **600 kg**

- Up to 6 pads, modular layout
- Electrically operated via wired control
- Vacuum pump onboard
- Two independent vacuum circuits
- 360° rotation, tilt and swing
- Ø400 or Ø290 pads for glass, marble and slabs
- Special pads for monopanel
- "Blow-off" function for easy release
- Ball joint on pads for improved adaptability

ENDLESS PADS CONFIGURATIONS

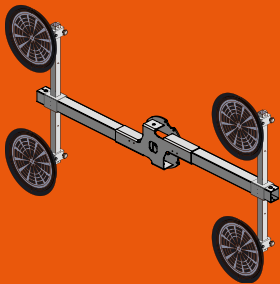

Standard

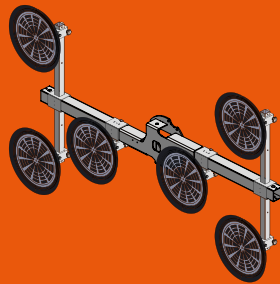

Ø400 - 6 pads

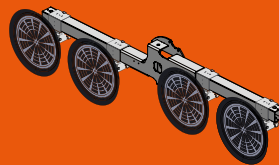

Ø400 in-line

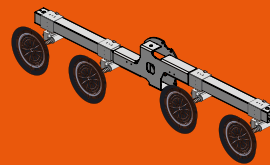

Ø290 in-line

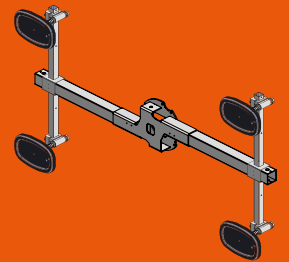

Monopanel

and more...

Manipulator Load Chart

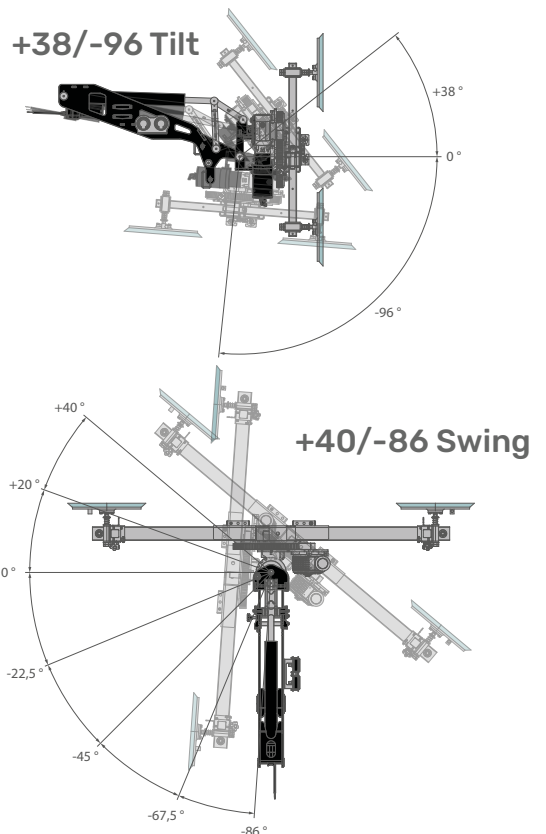
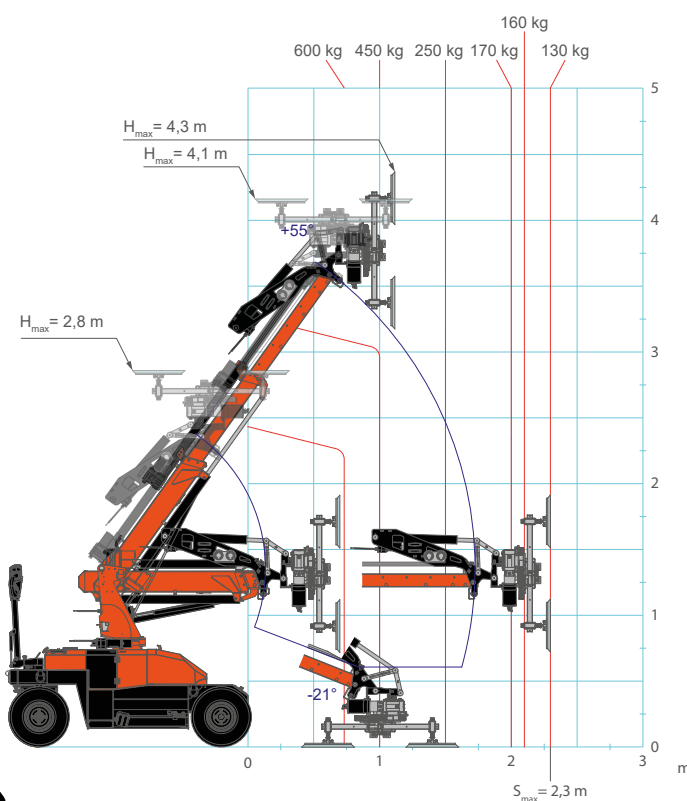

SEARCHER HOOK

600 kg

- 4 angles: +15° / 0° / -30° / -60°
- Increases versatility
- Stowed onboard



MANIPULATOR HOOK

400 kg

- Quickly installed on manipulator frame
- Electrical tilt and swing

HOOK

600 kg

- 600 kg

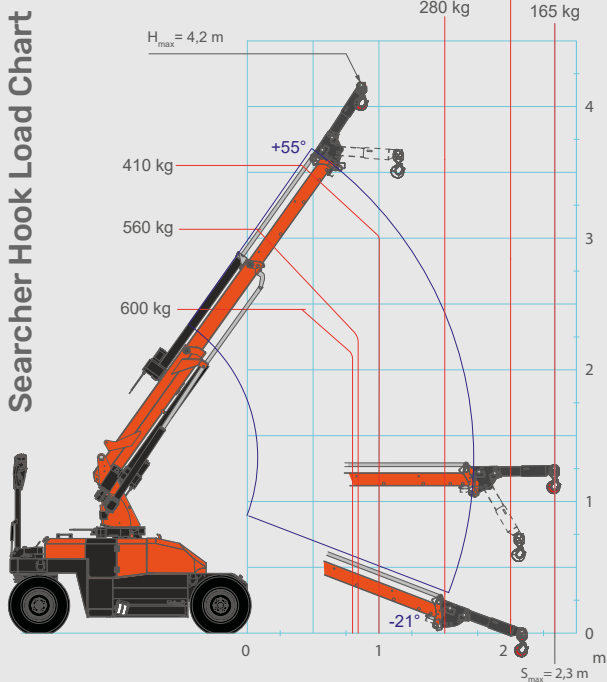
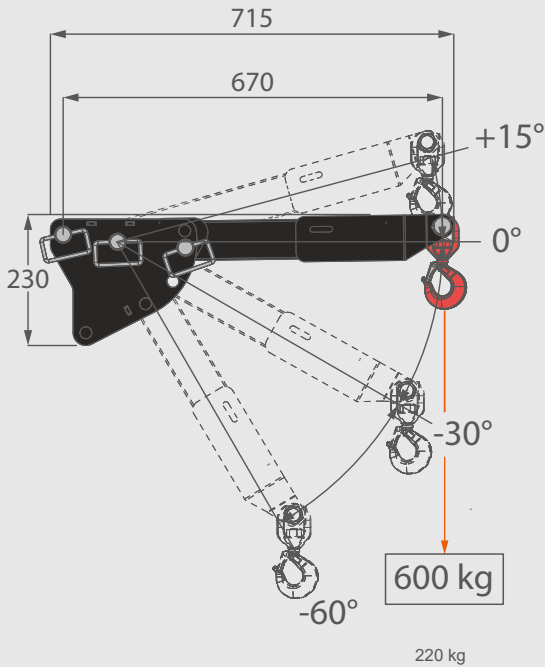

Manipulator Hook Load Chart

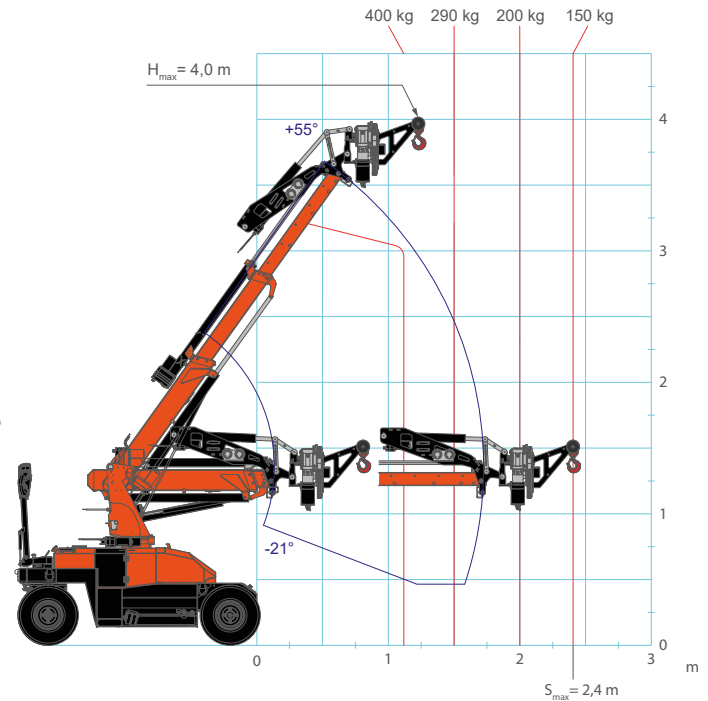

Hook Load Chart

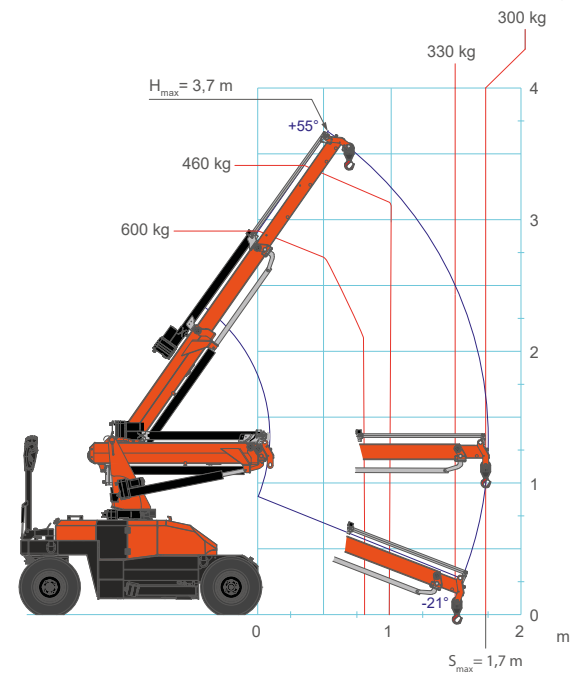



WIRED CONTROL

- Simple and intuitive
- Controls machine driving, crane and manipulator
- Self-diagnostics & emergency button

BOOM MOBILITY

- Turret side rotation $\pm 10^\circ$
- -21° to $+55^\circ$ boom angle
- Double boom extension

FULLY ELECTRIC

- Battery powered, lead-acid type 24 V 155 Ah
- Minimal maintenance costs
- Emission-free indoor operation
- On board 110V or 230V fast battery charger
- Runtime over 1 workday



MODULAR BALLAST

- Easily removable ballast modules
- Operates with reduced ballast
- Automatic lifting capacity adjustment
- 191 kg total weight

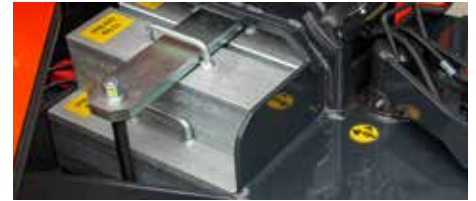

EASY TO DRIVE EVERYWHERE

- Front-wheel drive with differential
- Wide steering angle
- Side stabilisers



OUTDOOR-INDOOR WHEELS

- Off-road tyres (foamed puncture-proof)
- Non-marking white tyres for indoor *



J-LINK POWERED BY TRACKUNIT*

- Remote fleet monitoring and diagnostics
- Built-in or retrofit on existing units



*Optional



MPK06.2
2IN1 MINIPICKER



Barcelona
938498388
Valencia
961344394

Madrid
918951758
Vitoria
945365601

www.transgruas.com
info@transgruas.com