

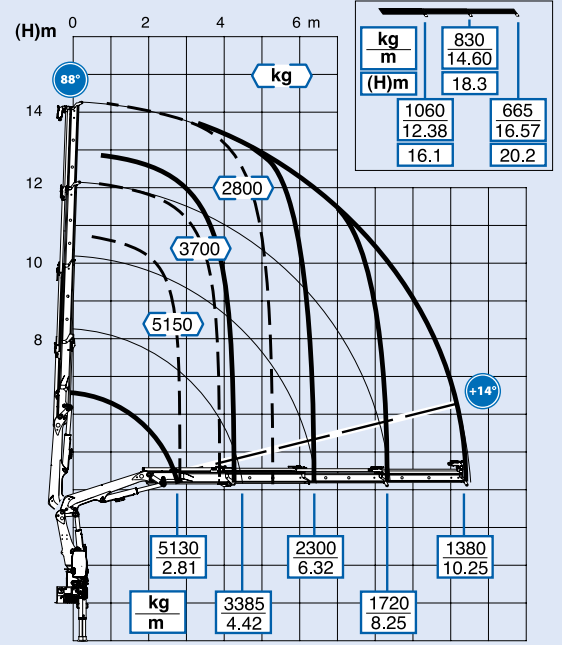

175

3S



2S/3S/4S/5S/6S

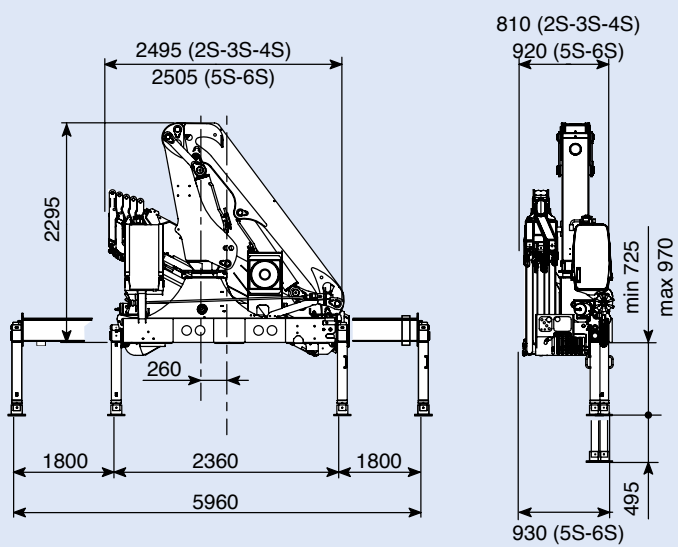

[mm]

STANDARD



OPTIONAL



» FOR MORE INFO AND TECHNICAL DETAILS GO TO **EFFER PRODUCT GUIDE**

DESCRIPTION	UNIT OF MEASURE	1S*	2S	3S	4S	5S	6S
Max. hydraulic outreach Massimo sbraccio idraulico orizzontale Max. hydraulische Reichweite waagerecht Portée hydraulique horizontale maxi. Máximo alcance hidráulico horizontal	m	6,39	8,32	10,40	12,53	14,75	16,72
Max. lifting moment (+20°) Momento massimo di sollevamento (+20°) Max. Hubmoment (+20°) Moment de levage maxi. (+20°) Momento máximo de elevación (+20°)	kgm	15720	15260	14970	14570	14170	13880
	kNm	154,20	149,70	146,90	142,90	139,00	136,20
Slewing arc Angolo di rotazione Schwenkbereich Angle de rotation Ángulo de giro	(°)	400					
Slewing Capacity - Max slope Capacità di rotazione - Massima pendenza Rotationskapazität - Maximale Neigung Capacité de rotation - Pente Maxi Capacidad de rotación - Máxima inclinación	%	8,7					
Working pressure Pressione d'esercizio Betriebsdruck Pression de travail Presión de trabajo	bar	350					
Recommended oil delivery Portata d'olio consigliata Empfohlene Ölfördermenge Débit d'huile recommandé Caudal de aceite aconsejado	l/min	70					
Oil tank capacity Capacità serbatoio olio Öltankkapazität Capacité du réservoir d'huile Capacidad tanque de aceite	l	80					
Weight of the standard crane (± 2%) Peso gru standard (± 2%) Gewicht des Standardkranes (± 2%) Poids propre de la grue standard (± 2%) Peso grúa estandard (± 2%)	kg	1715	1855	1985	2110	2220	2305

* Special version available on request / Versione speciale disponibile su richiesta / Sonderausführung auf Anfrage vorhanden
Version spéciale disponible sur demande / Version especial disponible en solicitar