

MULTI-LOADER FX & RT ATTACHMENTS

CRAWLER CARRIER



ALMACRAWLER

MULTI-LOADER FX & RT ATTACHMENTS

The Multi-Loaders comes with a wide range of fully installable, completely independent attachments to amplify its range of applications and allow operators to achieve more.

I Multi-Loader sono dotati di un'ampia gamma di accessori autonomi, facilmente installabili, che permettono di ampliare la gamma di applicazioni del trasportatore cingolato.

Lifter KIT

KLM 1.0 - KLM 2.0

Fully removable hydraulic scissor lift table available in two options

Piano a forbice completamente rimovibile disponibile in due opzioni

ML 3.0 FX, ML 3.0 RT

	KLM 1.0		KLM 2.0		
	METRIC	IMPERIAL	METRIC	IMPERIAL	
Max capacity	1000 Kg	2200 lbs	400 Kg	880 lbs	Capacità max
Weight (empty)	415 Kg	915 lbs	490 Kg	1080 lbs	Peso (a vuoto)
Battery	12 V 100 Ah with charger on board (110V-230V)		12 V 100 Ah with charger on board (110V-230V)		Batteria



Self-standing kit

Kit autoportante



KML 1.0

KML 2.0

Dumper KDM13

Installable dumper kit, rotating base, and radio remote controlled

Kit dumper installabile, piano rotante e radiocomando

ML 3.0 FX, ML 3.0 RT

KDM13



Swivel platform

Rotazione del pianale



	KDM 13		
	METRIC	IMPERIAL	
Max capacity	1300 Kg	2870 lbs	Capacità max
Weight (empty)	380 Kg	840 lbs	Peso (a vuoto)
Struck volume	0.6 m3	21 ft3	Volume raso
Rated volume (ISO 6483)	0.65 m3	23 ft3	Volume max (ISO 6483)
Battery	12 V 100 Ah with charger on board (110V-230V)		Batteria

Battery Trolley

Custom design trolley to allow easy removal and storage of battery pack.

Trolley progettato su misura per estrarre e trasportare facilmente la batteria.

ML 3.0 FX

Max capacity 170 Kg / 375 lbs
Weight (Peso) 30 Kg / 66 lbs



Multiframe

Double-sided a-frame rack for the safe transport and storage of windows, flat glass or insulating glass units.

A-Frame per il trasporto sicuro di finestre, vetri piani o vetrate isolanti.

ML 1.5 FX, ML 3.0 FX, ML 3.0 RT

Max capacity 1300 Kg / 2870 lbs
ML 1.5 FX (650 Kg / 1435 lbs for each side)

Max capacity 2400 Kg / 5290 lbs
ML 3.0 FX / RT (1200 Kg / 2645 lbs for each side)

Weight (Peso) 145 Kg / 320 lbs

Dolly

Support extension - helps carry extra-long loads easily

Accessorio estensivo del pianale: aiuta a trasportare facilmente i carichi più lunghi

ML 1.5 FX, ML 3.0 FX, ML 3.0 RT

Swivel plate for ML 1.5 FX

Pianale girevole per ML 1.5 FX

Max capacity 1400 Kg / 3090 lbs
Weight (Peso) 100 Kg / 220 lbs

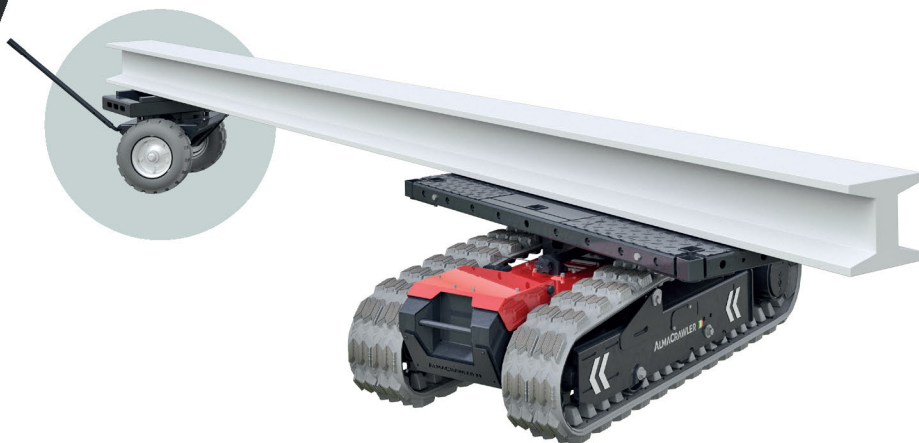

Max capacity 1500 Kg / 3310 lbs
Weight (Peso) 125 Kg / 275 lbs

Rear tow hook

Rear hook for towing loads.

Gancio posteriore per il traino di carichi.

ML 3.0 FX, ML 3.0 RT

Weight (Peso) 8 Kg / 18 lbs



Max capacity 1450 Kg / 3200 lbs
ML 1.5 FX

Max capacity 2950 Kg / 6500 lbs
ML 3.0 FX / RT

Weight (Peso) 50 Kg / 110 lbs

Forest, Pipe & Drywall Kit

Kit for safe transport of logs, pipes or drywall.

Kit per il trasporto sicuro di tronchi, tubi o cartongesso

ML 1.5 FX, ML 3.0 FX, ML 3.0 RT



Scraper & Blade Kit

Scraper and blade kit for ground cleaning.

Kit raschiatore e lama per la pulitura del suolo.

ML 1.5 FX

Weight with counterweight 700 Kg / 1545 lbs
(Peso con zavorra)

Weight without counterweight 200 Kg / 440 lbs
(Peso senza zavorra)



Crane Kit

KMC 3.1

Crane kit for Multi-Loader 3.0 FX and RT.

Kit gru per i Multi-Loader 3.0 FX e RT.

ML 3.0 FX, ML 3.0 RT

Max capacity 990 Kg / 2180 lbs
ML 3.0 FX / RT

Weight (Peso) 510 Kg / 1125 lbs

ALMACRAWLER 

Crane Kit - KMC 3.1

ML 3.0 FX / 3.0 RT

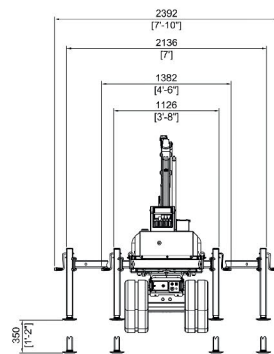
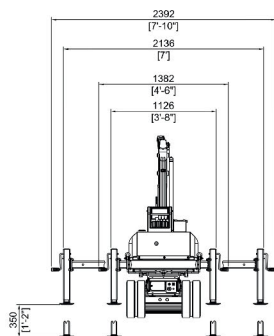
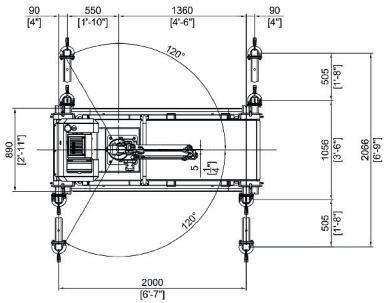
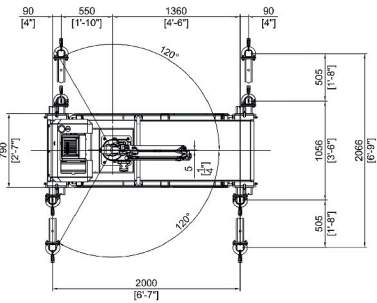
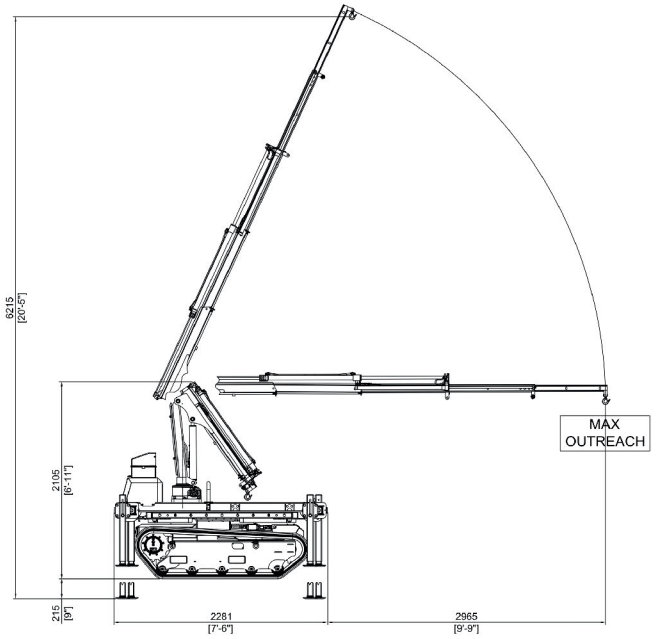
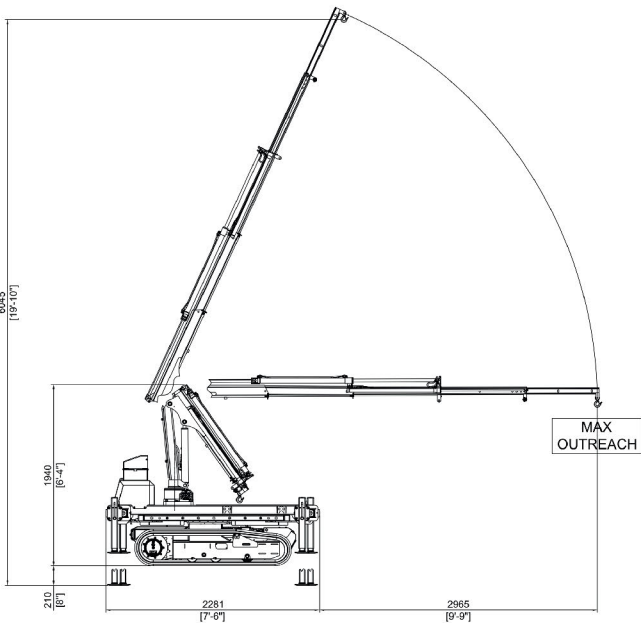
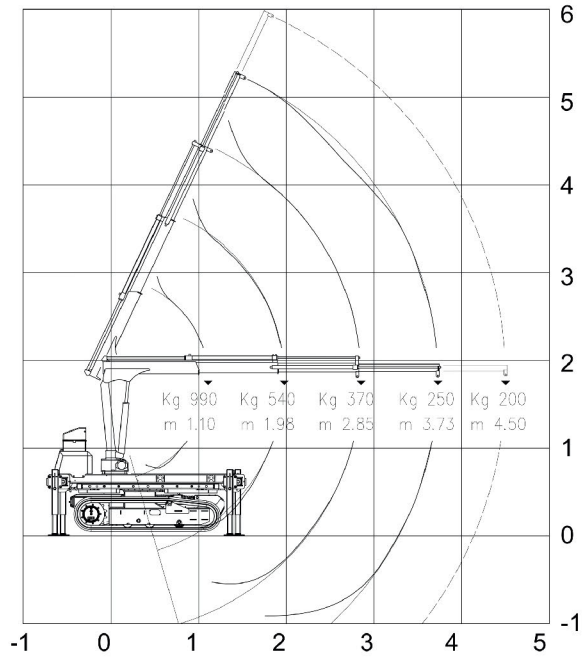

MULTI-LOADER FX & RT ATTACHMENTS

Multiframe

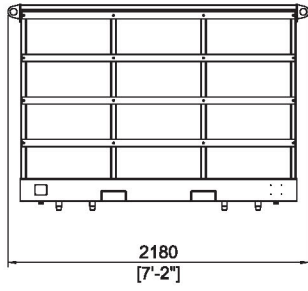

ML 1.5 FX

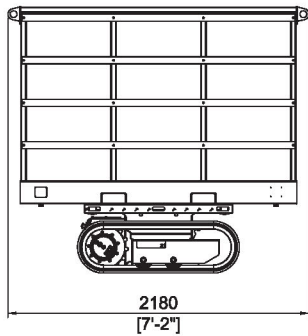

ML 3.0 FX / ML 3.0 RT

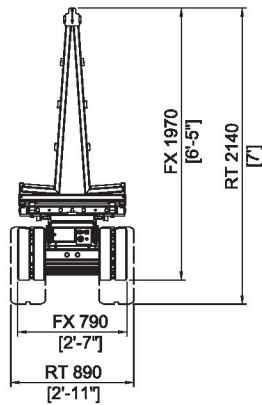
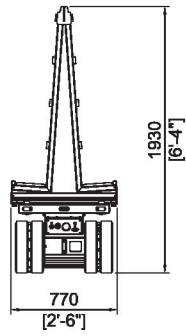
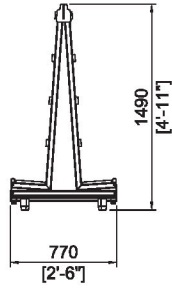
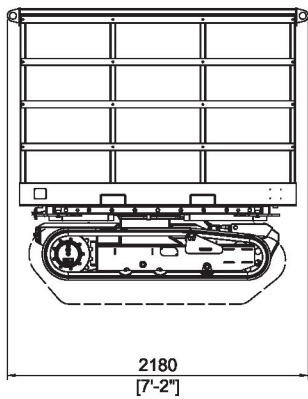

Battery Trolley

ML 3.0 FX

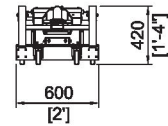
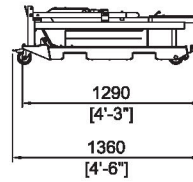
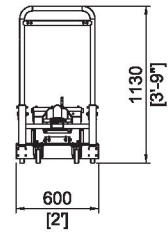
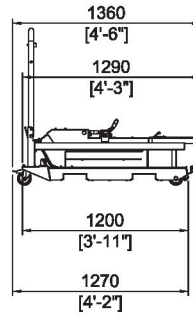

Dolly

ML 3.0 FX

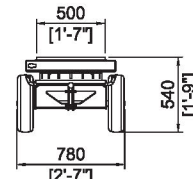

ML 3.0 RT / 1.5 FX

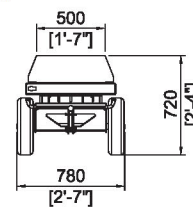

Forest kit

ML 1.5 FX

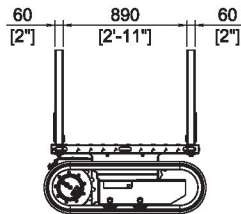
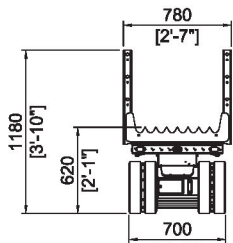

ML 3.0 FX / 3.0 RT

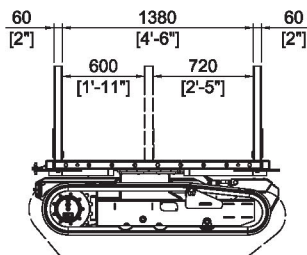
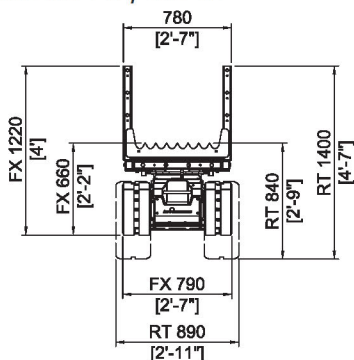

Swivel plate

ML 1.5 FX

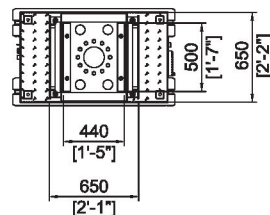
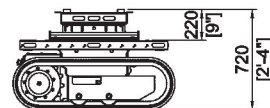

Lifter Kit

ML 3.0 FX / 3.0 RT

KLM 1.0

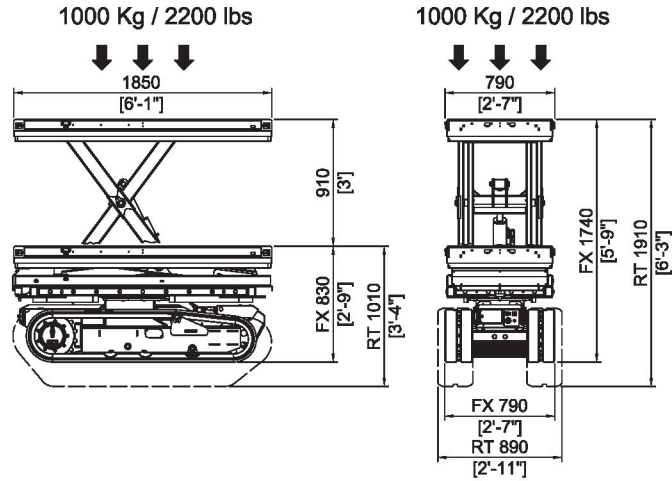

KLM 2.0

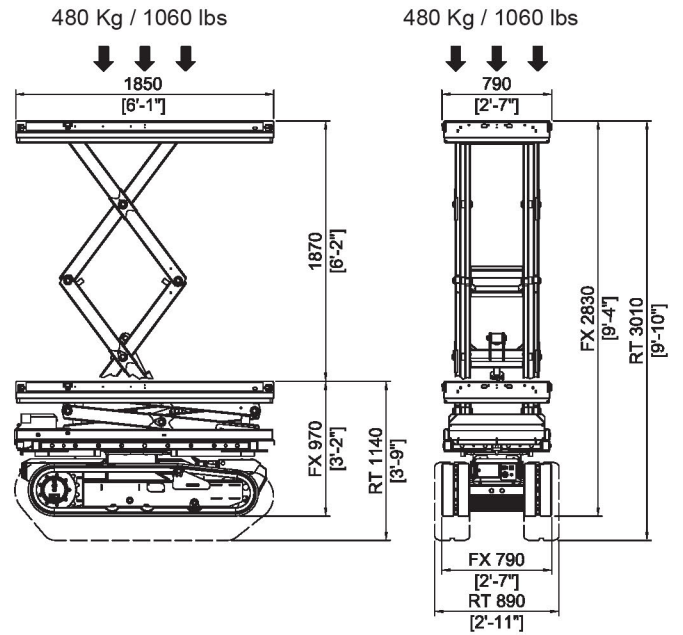

Dumper KDM13

ML 3.0 FX / 3.0 RT

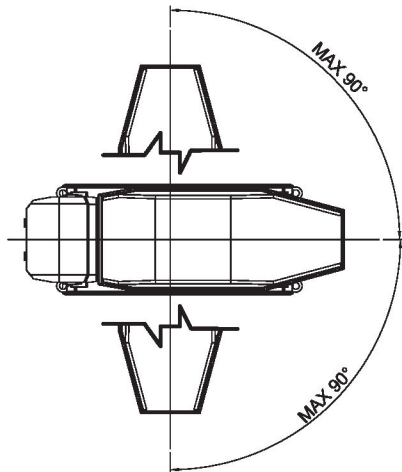
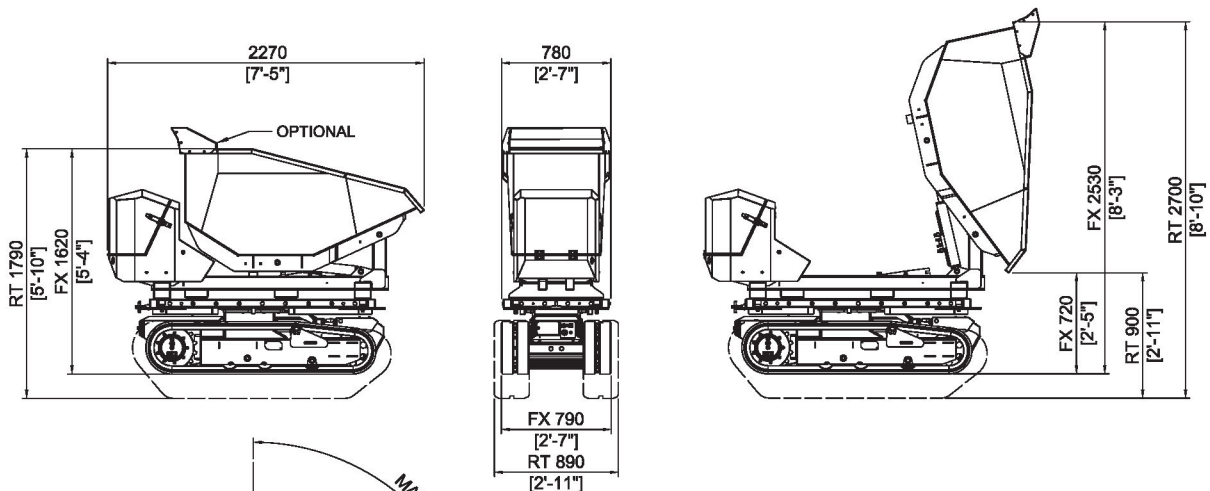

Rear tow hook

ML 3.0 FX

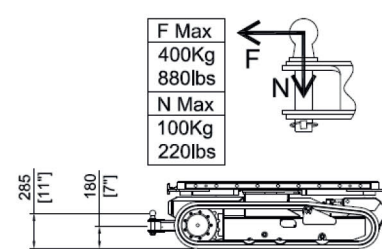

ML 3.0 RT

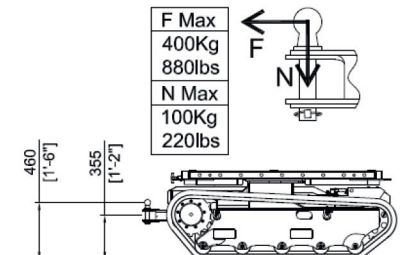

Pipe Kit

ML 1.5 FX

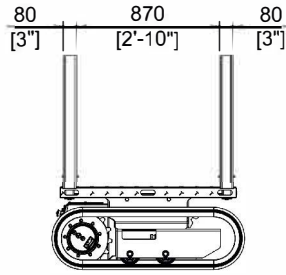
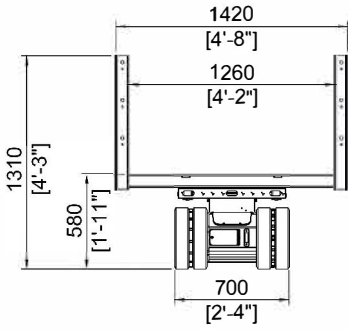

ML 3.0 FX / 3.0 RT

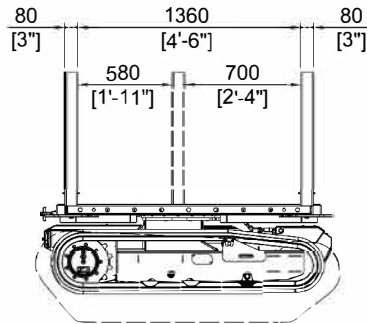
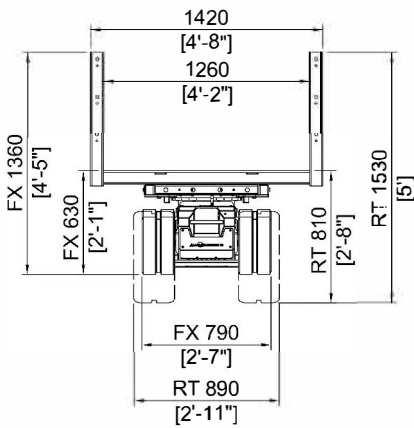

Blade Kit

ML 1.5 FX

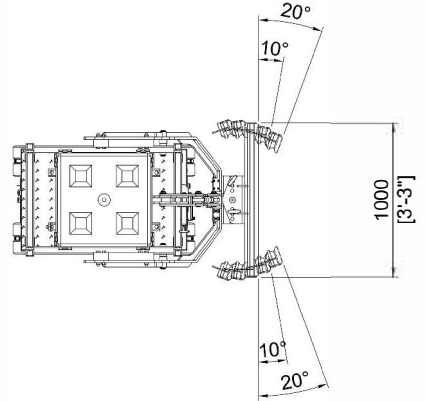
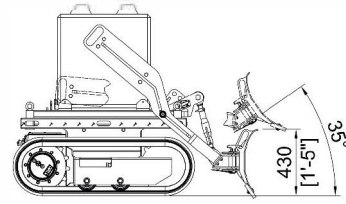

Drywall Kit

ML 1.5 FX

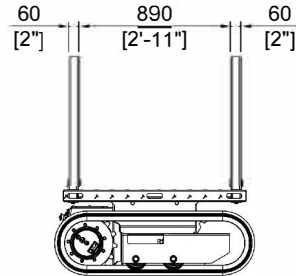
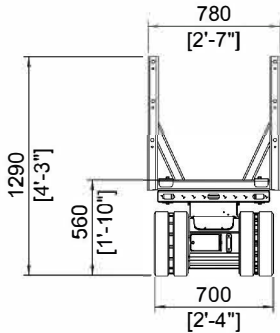

ML 3.0 FX / 3.0 RT

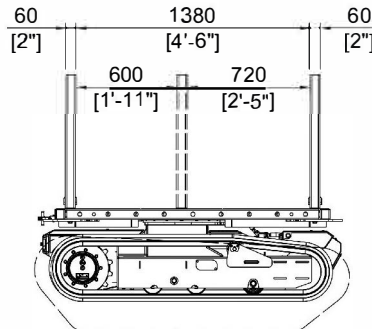
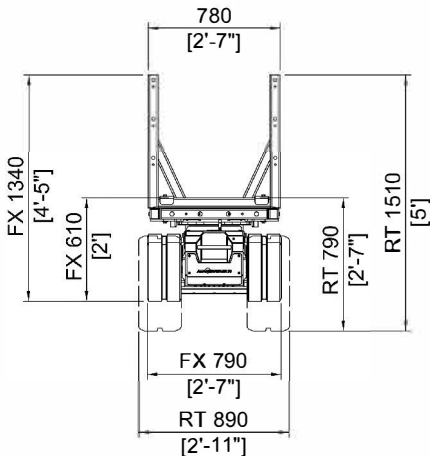

Scraper Kit

ML 1.5 FX

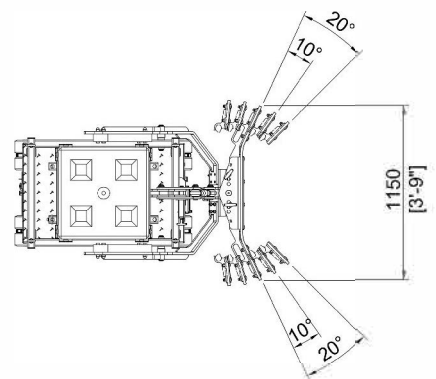
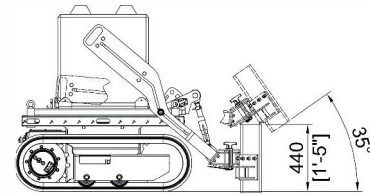

Barcelona

938498388

Valencia

961344394

Madrid

918951758

Vitoria

945365601

www.transgruas.com

info@transgruas.com