

GORMAGH

12000-E

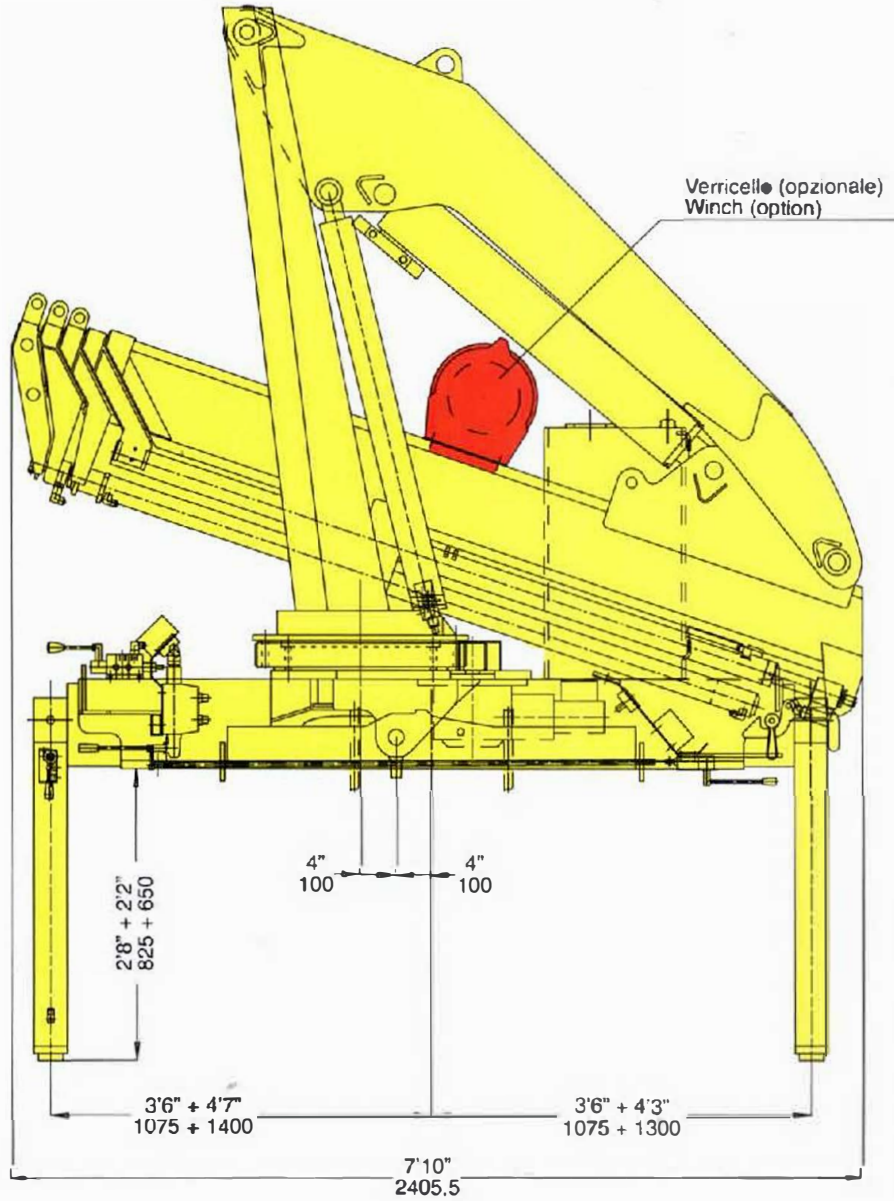

GORMAGH 12000

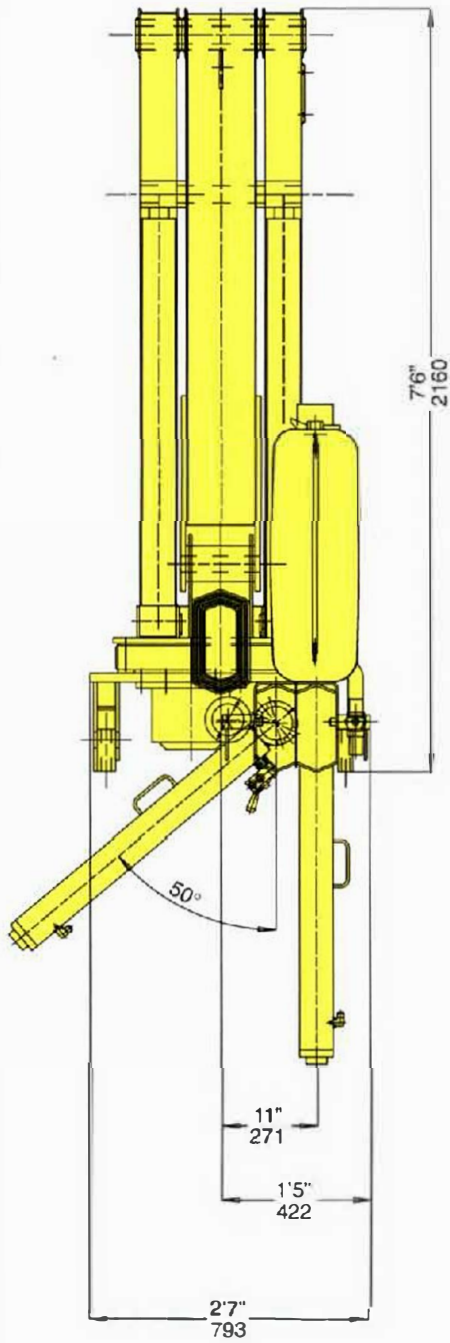

A fronte di una continua ricerca tecnologica i dati possono cambiare senza preavviso. Contattate il nostro Ufficio Commerciale per ulteriori informazioni.
 Because of continuous technology research data can change without notice. Please, contact our Commercial Dept. for further information.
 A cause de une continue recherche technologique les données peuvent changer sans préavis. Contacter notre Bureau Commercial pour des autres informations.
 Inmum und technische Änderung vorbehalten Masse und Gewichte unverbindlich. Unser Vertrieb erteilt Ihnen gerne weitere Auskunft. Bitte rufen Sie uns an.
 Debido a los continuos avances tecnológicos los datos pueden variar sin notificación previa. Para más información rogamos contactar nuestro Departamento Comercial.

STANDARD



Rotazione 360°
 Rotation 360°
 Rotazione 360°
 Drehbereich 360°
 Rotación 360°



Stabilizzatori gru base girevoli
 Tilt up outriggers
 Stabilisateurs tournant
 Drehbare Stützen
 Estabilizadores giratorios de la grúa base



Comandi bilaterali
 Dual control stations
 Commandes à gauche et à droite
 Beidseitige Bedienung
 Mandos bilaterales



Comando supplementare non attivato
 Additional free section not activated
 Section du distributeur pas activée
 Zusätzlicher steuerschieber
 Mando auxiliar no activado

OPTIONAL



Limitatore di momento
 Load limiting device
 Limiteur de charge
 Überlastschutzvorrichtung
 Limitador de momento (de carga)



Rotazione continua
 Continuous rotation
 Rotation continue
 Endlos Schwenkwerk
 Rotación continua



Prolunghe meccaniche
 Manual extensions
 Rallonges manuelles
 Manuelle Verlängerungen
 Prolongas mecánicas



Stabilizzatori gru base estensibili idraulicamente
 Outriggers with hydraulic extension
 Stabilisateurs avec extension hydraulique
 Hydraulisch ausfahrbare Stützen
 Estabilizadores grúa base desplegables hidráulicamente



Radiocontrol
 Radio remote control
 Radiocommandes
 Funkfernsteuerung
 Radiomando



Telecomando
 Cable remote control
 Télécommandes
 Kabelfernsteuerung
 Control remoto



Verricello
 Winch
 Treuil
 Seilwinde
 Cabrestante



Posto di manovra in alto
 Top seat
 Siège en haut
 Hochsitz
 Puesto de maniobra en alto



Utilizzo con attrezzo
 Additional accessories
 Utilisation avec accessoire
 Zubehör
 Accesorios auxiliares



Comando supplementare attivato
 Additional function
 Section du distributeur activée
 Zusatzfunktion
 Mando auxiliar activado



Traversa ausiliaria fissa
 Additional outriggers beam without extension
 Stabilisateurs supplémentaires sans élargissement
 Zusätzliche Abstützbeine
 Estabilizadores suplementarios fijos



Traversa ausiliaria estensibile
 Additional outriggers with lateral extension
 Stabilisateurs supplémentaires avec élargissement
 Ausfahrbare Zusatz-Stützen
 Estabilizadores adicionales con extensión lateral



Piastre maggiorate
 Large ground plates
 Plaque stabilisateurs
 Bodenplatten
 Placas estabilizadoras de suelo de gran tamaño



Trattamento marino della gru
 Marine treatment of the crane
 Traitement marin de la grue
 Marinebehandlung des Kranes
 Tratamiento especial: marino de la grúa



Pompa a portata variabile
 Pump with load sensing
 Pompe à débit variable
 Variablepumpe load sensing
 Bomba de caudal variable



Cestello
 Basket
 nacelle
 Personenkorb
 Cesta