

L400 Series

HYUNDAI WIA Heavy Duty CNC Turning Center



Technical Leader

The CNC Turning Center L400 series, designed by Hyundai WIA with years of expertise and the latest technology, is a Turning Center that maximizes productivity and performance.



MODEL	Spindle			Bed		Turret		
	12"	15"	Big Bore	Standard	Long	10 Station	12 Station	Turn Mill
L400A	●			●			●	
L400MA	●			●			●	●
L400C		●	○	●		●		
L400LC		●	○		●	●		
L400MC		●	○	●			●	●
L400LMC		●	○		●		●	●

Heavy-Duty, Large Work Capacity,
CNC Turning Center

L400 Series

- Rigidity secured through box guideways.
- One-piece structure for high accuracy and sturdiness
- Pretensioned double anchored method provides high precision
- Main spindle heat displacement minimized
- Main spindle driven by 2-step gear box (L400MA : Belt)
- Optional big bore spindle is available (L400C series)



01

L400 Series

Basic Features

High Rigid Bed & Structure for Heavy Duty CNC Turning Center

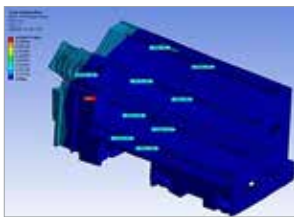

01

High Precision, High Rigidity One-Piece Structure

The L400 features a 45° slant bed design which is developed through finite element analysis (FEA) to absorb vibration and minimize thermal growth. This ensures a stabilized platform for powerful, precise cutting capabilities.

Box Guideway

For all axes of the L400 series, Box guideways provide unsurpassed long term rigidity and accuracy, even during heavy duty cutting.



02

2 Step Gear Box (L400MA : Belt)

A two-step driving method is applied inside the main spindle as standard on non mill turrets. It provides powerful torque at low speeds and stable rotation at high speeds.



03

Ball Screw

Travel is stabilized by fastening both ends of the ball screw using the double anchored method. In particular, a large diameter ball screw with proper preload reinforces sturdiness and resistance to thermal displacement.

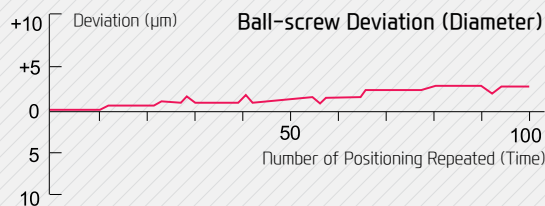

Mill Turret (BMT75P)

The BMT turret, with 4 screws solidly fastening the holder, shows outstanding performance in powerful cutting and is capable of machining complex products by using milling tools.



04

Basic Features

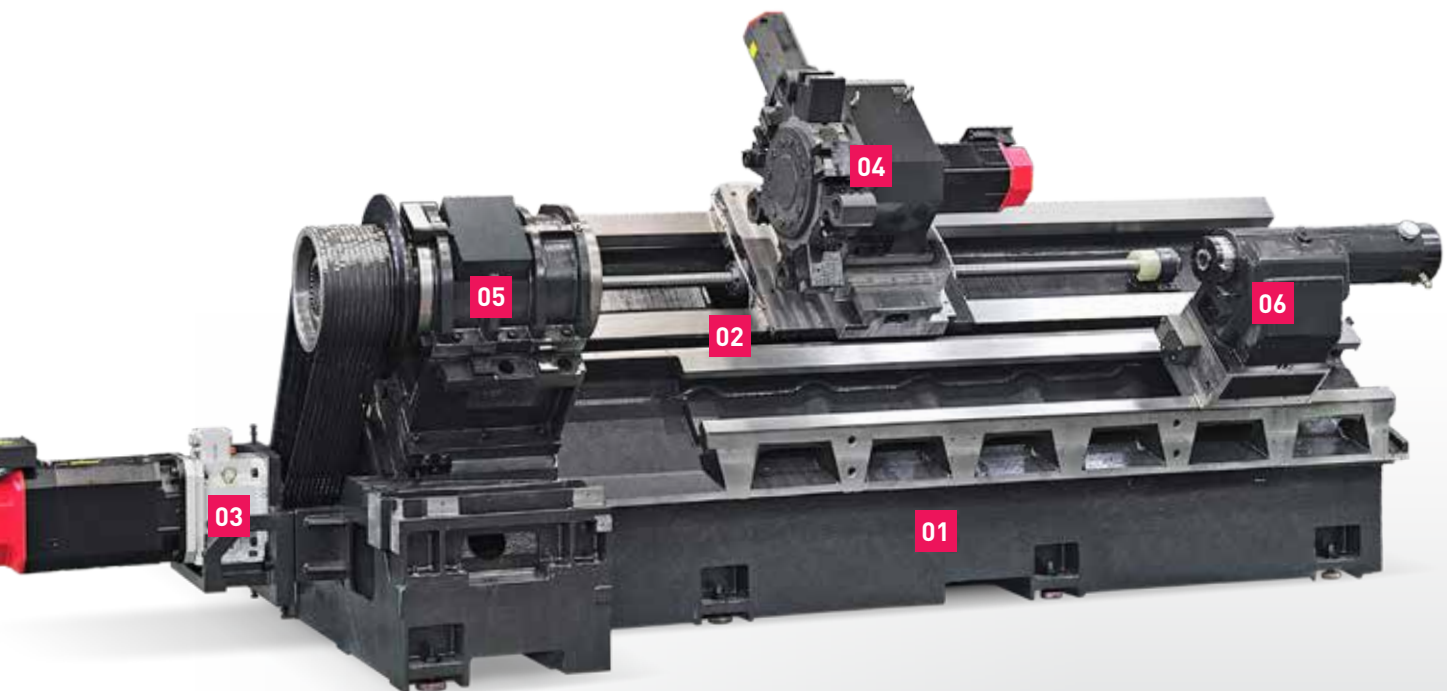

Powerful Cutting Capability & Wide Cutting Area

- ◎ **Travel (X/Z)** L400A | MA | C : 325/1,205 mm (12.8"/47.4"), L400MC : 320/1,200 mm (12.6"/47.2"), L400LC | LMC : 320/2,200 mm (12.6"/86.6")

Main Spindle

The main spindle has become sturdier by enlarging the diameter and thickness. Rigidity and accuracy are maintained by adopting high precision angular ball bearing.

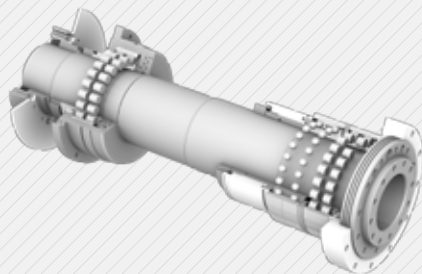

05

Built-in Tail Stock

Built-in type tail stock provides stabilized surface finish during heavy duty cutting.



06

L400 Series

High Precision Spindle

Long Lasting High Accuracy & Excellent Performance
CNC Turning Center



Main Spindle

- The thermally symmetrical headstock has a special heat insulation board which blocks the heat and maintains high accuracy during long and continuous operations.
- To accomplish advanced stability even during heavy duty cutting, a combination of P4 double cylindrical roller bearings and angular bearings are adopted.
- The double locking device separates the spindle bearing and pulley to prevent a decrease in spindle bearing pretension during interrupted cutting, heavy duty cutting, chuck cylinder operation, and by belt pulley tension.

C-Axis Control

- C-axis control function and rotary tools are provided as standard on the "M" type of L400 Series.
- **Optional Gearless Spindle is available in L400MC/LMC models, enabling the machining of various shapes in utmost quality.**

SIEMENS Motor

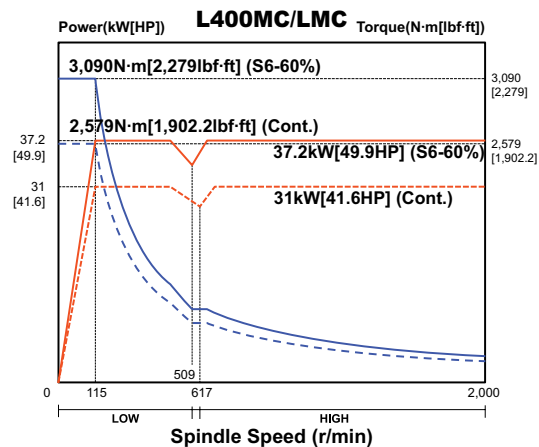
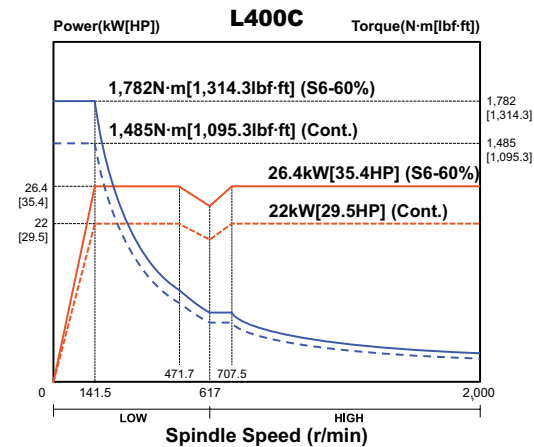
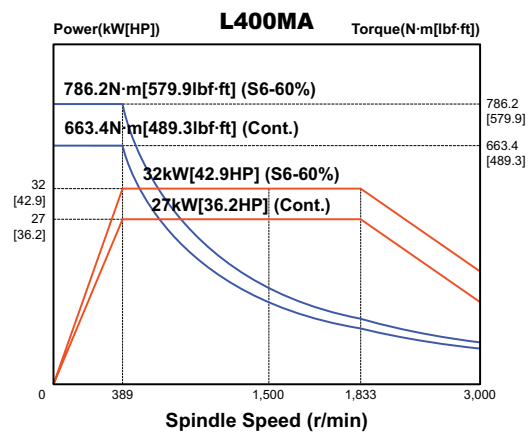

FANUC Motor

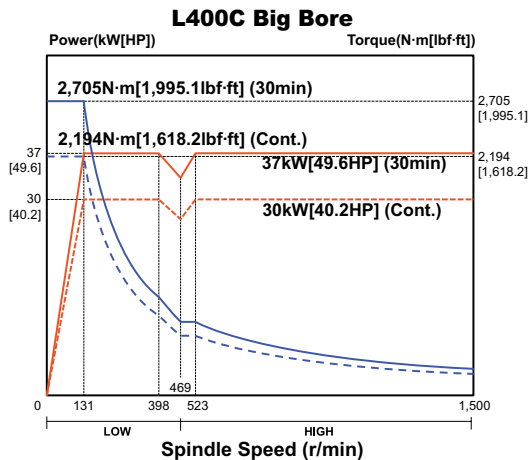
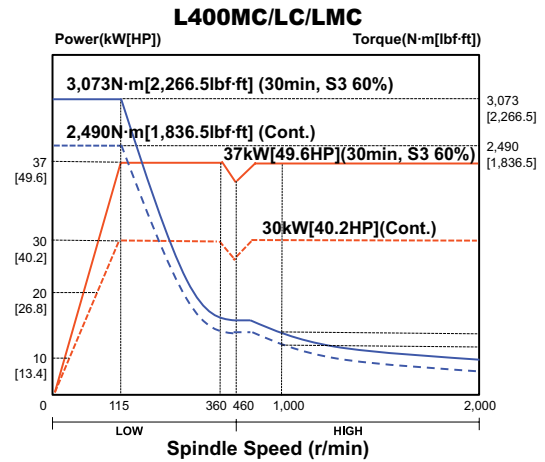
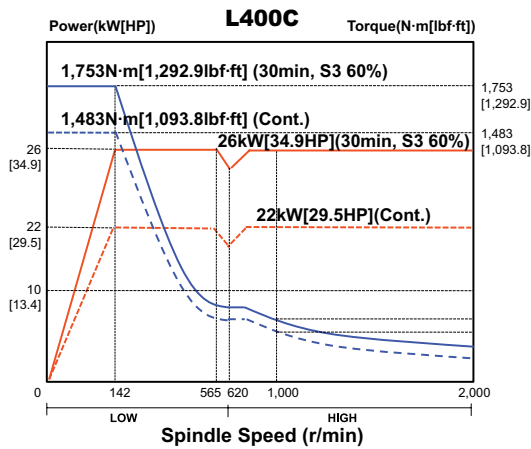
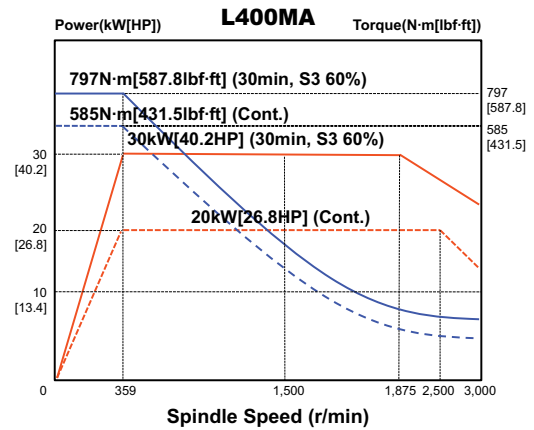
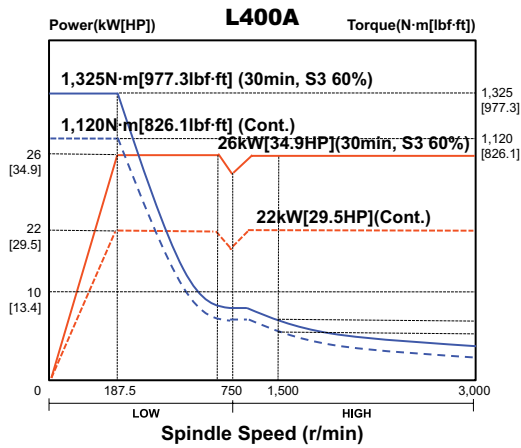

N3

L400 Series

Servo Turret

High speed, High Accuracy, Highly Reliable
Servo Turret



L400A

- Number of Tools : 12 EA
- Tool Size (O.D/I.D)
□ 25/Ø50 (□ 1"/Ø2")
- Indexing Time : 0.2 sec/step

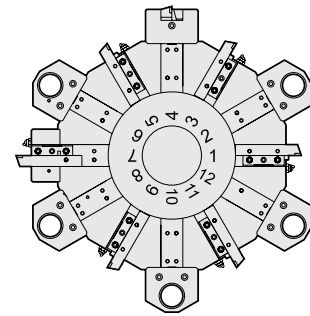

L400C/LC

- Number of Tools : 10 EA
- Tool Size (O.D/I.D)
□ 32/Ø50 (□ 1.2"/Ø2")
- Indexing Time : 0.2 sec/step

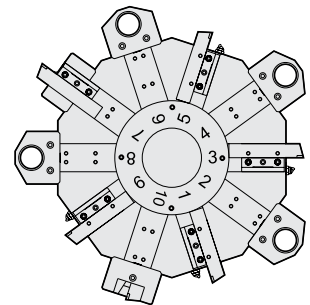

Turret

The L400 Series' large 12-station turret provides left or right facing tools in all positions. The Bi-directional rotation turret is attached to a Ø260 (Ø10.2") diameter curvic coupling and is driven by a high torque motor. 1/8,000 degree repeatability under 11 tons of clamping force enables high precision machining and heavy duty cutting.

Mill Turret (BMT)

The BMT75 turret is provided as standard for the "M" type of L400 Series, enhancing high precision milling process.

Mill turrets is driven by a high torque servo motor with a 0.2 second indexing time in either direction.



BMT75P

- ⦿ Output (Max./Cont.) : **7.5/5.5 kW (10/7.4 HP)**
- ⦿ Speed (rpm) : **4,000** r/min
- ⦿ Collet size : **Ø26 (Ø1") (ER40)**
- ⦿ Live Tool Type : **BMT75P**

L400MA

- ⦿ Number of Tools : **12** EA
- ⦿ Tool Size (O.D/I.D) : **□ 25/Ø50 (□ 1"/Ø2")**
- ⦿ Indexing Time : **0.2** sec/step

L400MC/LMC

- ⦿ Number of Tools : **12** EA
- ⦿ Tool Size (O.D/I.D) : **□ 32 / Ø63 (□ 1.2"/Ø2.5")**
- ⦿ Indexing Time : **0.2** sec/step

Straight Milling Head



Angular Milling Head



Mill Tool Holder

Machining capability is increased with the addition of a Straight Milling Head which can remove material from the side and an Angular Milling Head which can perform I.D. operations.

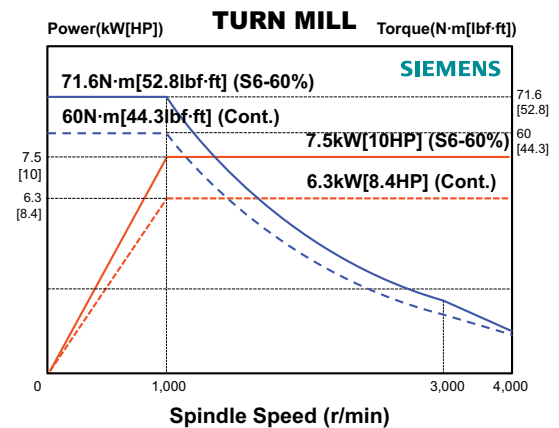
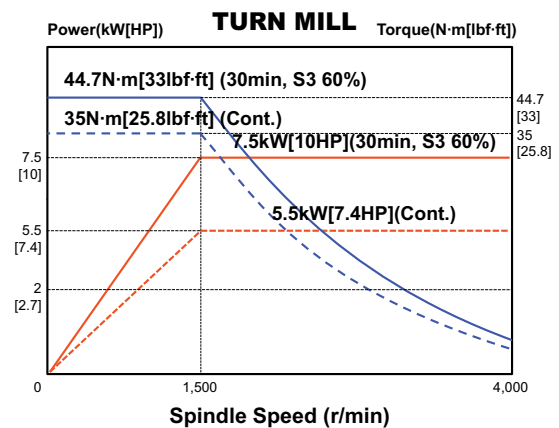

n4
L400 Series

Machining Capability

Excellent Performance, High Accuracy Cutting
CNC Turning Center

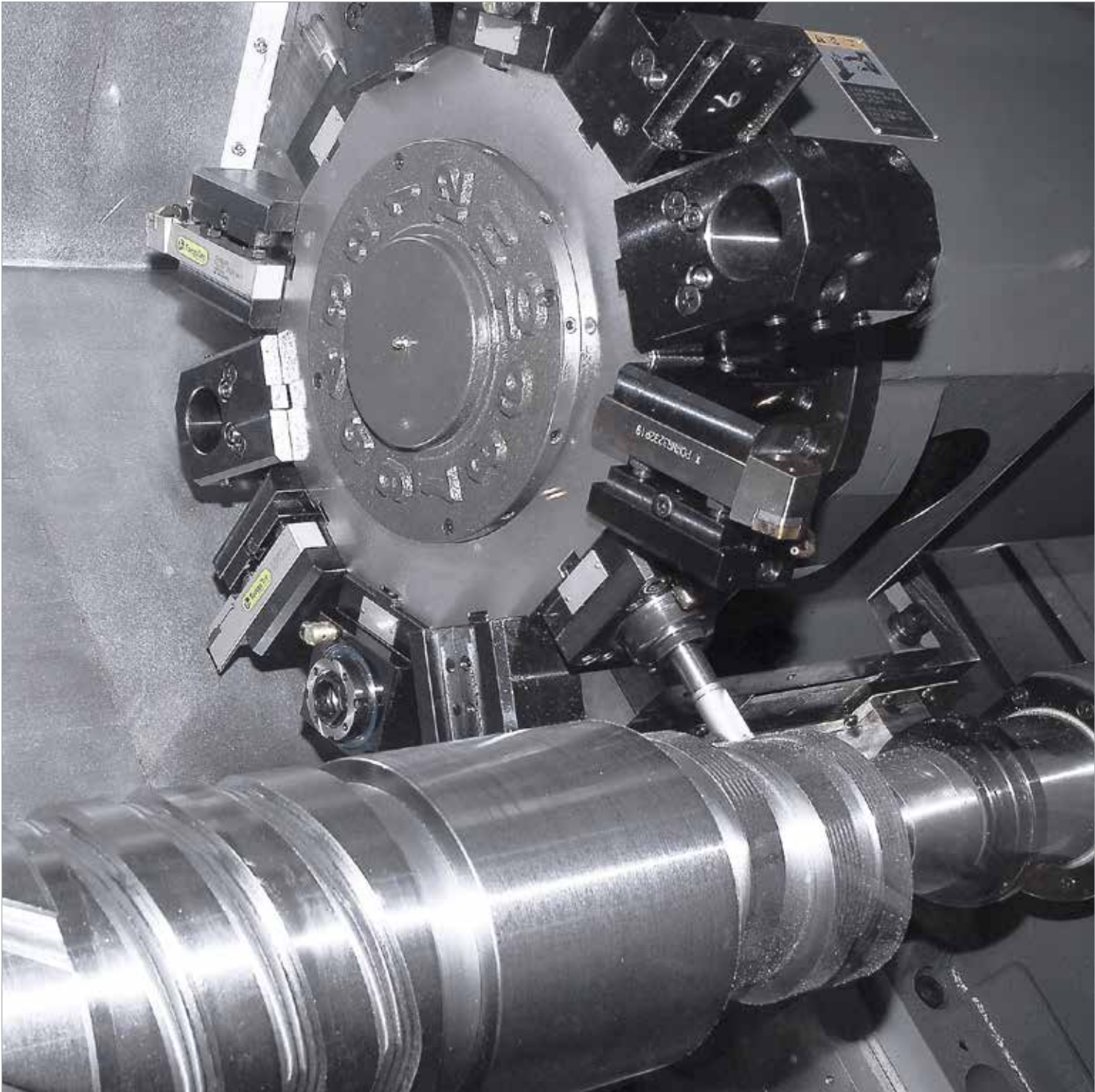

L400MA

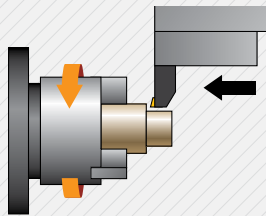

OD Cutting

(Material(JIS):S45C(Carbon steel))

Workpiece	Ø276
Spindle speed	284 r/min
Cutting depth	8 mm
Forwarding speed (Rev.)	0.45 mm/rev
Cutting speed	232 m/min
Chip discharge	835 cc/min

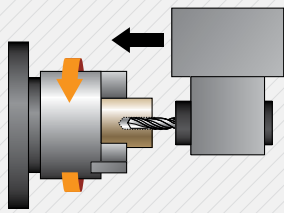

Drilling

(Material(JIS):S45C(Carbon steel))

Tool Dia.	Ø40
Spindle speed	214 r/min
Cutting depth	80 mm
Forwarding speed (Rev.)	0.36 mm/rev
Cutting speed	27 m/min
Chip discharge	774 cc/min

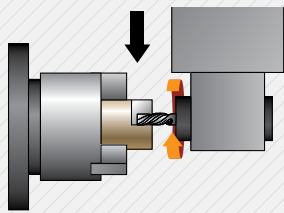

End Milling

(Material(JIS):S45C(Carbon steel))

Tool speed	1000 r/min
Cutting speed	63 m/min
Forwarding speed (Min.)	200 mm/min
Forwarding speed (Feed)	0.1 mm/f
Cutting depth	4.0 mm
Chip discharge	16 cc/min

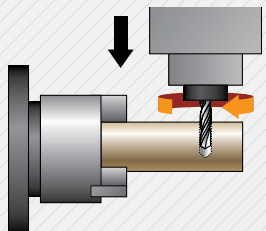

Drilling

(Material(JIS):S45C(Carbon steel))

Tool speed	390 r/min
Cutting speed	27 m/min
Forwarding speed (Min.)	117 mm/min
Forwarding speed (Rev.)	0.3 mm/rev
Cutting depth	40 mm
Chip discharge	44 cc/min

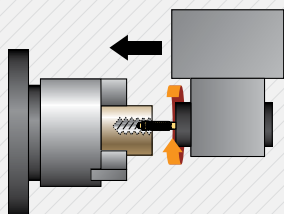

Tapping

(Material(JIS):S45C(Carbon steel))

Tap size	M20×2.5
Tool speed	127 r/min
Cutting speed	8 m/min
Forwarding speed (Min.)	317 mm/min
Forwarding speed (Rev.)	2.5 mm/rev
Cutting depth	30 mm

❖ The above results might be different by types of processing circumstances.

Machining Variation

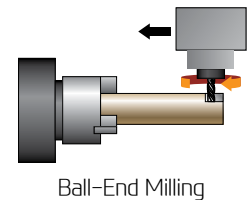
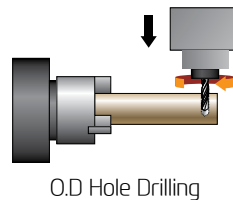
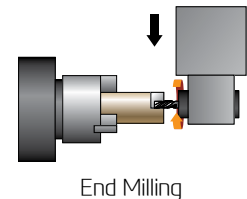
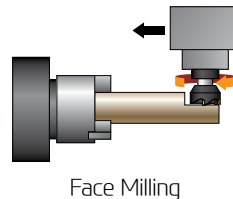
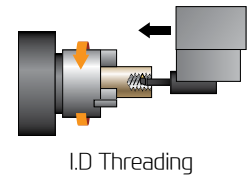
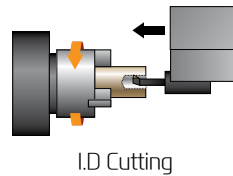
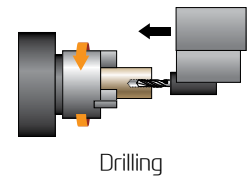
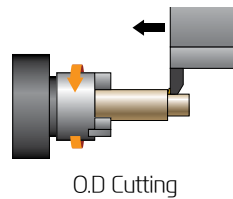

Sample Workpiece



05

L280 Series

Smart System



Software for Smart Operating and Machining

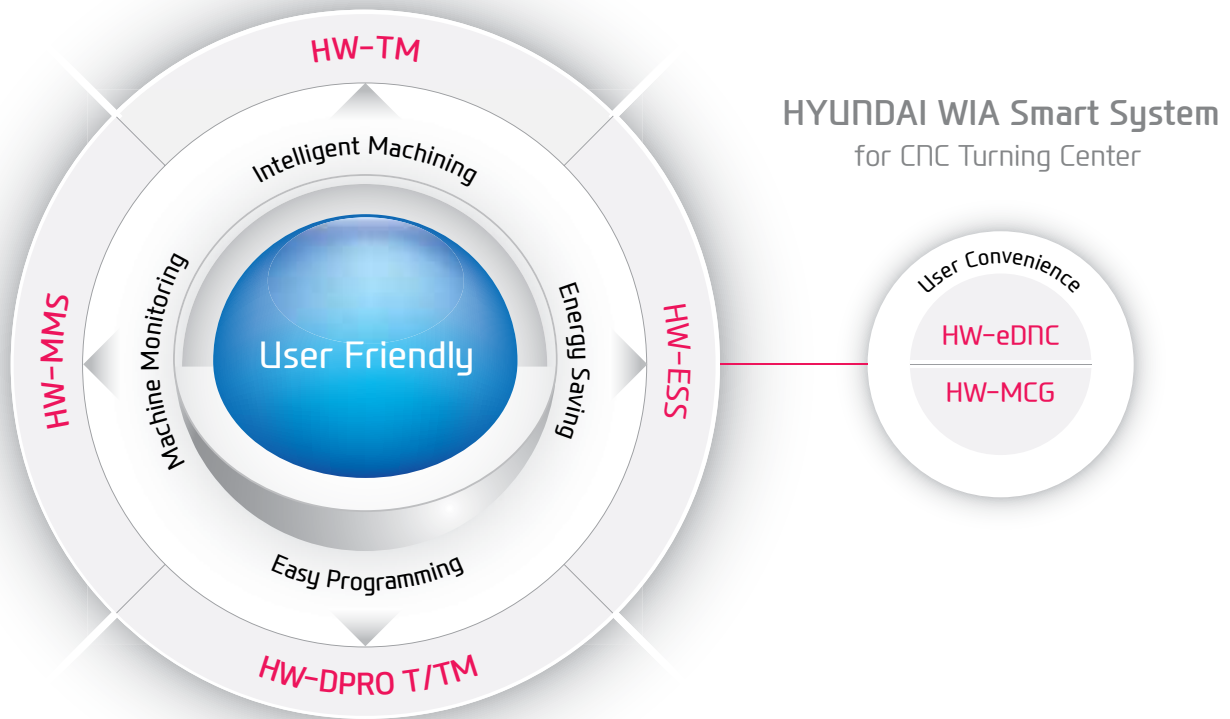

HYUNDAI WIA Smart System
for CNC Turning Center

Smart Factory HW-MMS (HYUNDAI WIA-Machine Monitoring System)

A brand new manufacturing machine by HYUNDAI WIA, HW-MMS is a unique software capable of monitoring the operation status of manufacturing machines in factories, a smart solution to improve manufacturing conditions of customers.

01 Real-time monitoring of machine operation status (Cloud)

02 History and statistics of machine operation (Cloud)

03 History and statistics of alarm occurrence (Cloud)

04 History and statistics of work count (Cloud)

05 Remote diagnosis (Remote)

HW-MMS Remote System

- 01 Real-time monitoring of machine operation status (Cloud)
- 02 History and statistics of machine operation (Cloud)
- 03 History and statistics of alarm occurrence (Cloud)
- 04 History and statistics of work count (Cloud)
- 05 Remote diagnosis (Remote)

Faster processing and enhanced accuracy in are possible through the **HYUNDAI WIA Smart System**. The user friendly software and equipment monitoring of the Smart System maximizes productivity.



HW-eDNC

HYUNDAI WIA ethernet
Direct Numerical Control

This software allows transmission of NC data between PC and a machine's CNC. The processing programs can be managed on the PC through the ethernet or serial communication.



HW-MCG

HYUNDAI WIA
Machine Guidance

Software that offers operation, maintenance, management monitoring and various user friendly features.



HW-TM

HYUNDAI WIA
Tool Monitoring

A tool monitoring software which analyzes the load of the spindle motor to determine and monitor possible damage of tools.



HW-ESS (Standard)

HYUNDAI WIA
Energy Saving System

An environmental friendly software that reduces the unnecessarily wasted standby power waiting for an operation.

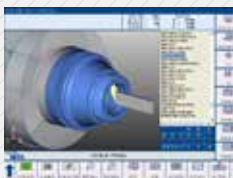

HW-DPRO T/TM HYUNDAI WIA Dialogue PROgram Turn/TurnMill

Using a dialogue method, this software makes it easy to work out a program for a lathe processing operation with complicated configurations. (Can be installed on a PC.)

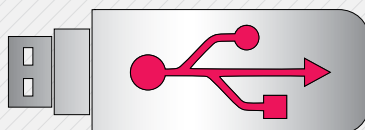

USB Port

Convenience is increased when inputting and outputting program. The USB port is available in addition to the former input output methods such as CF memmort card and LAN.

SIEMENS

DIFFERENTIATED CAPABILITIES, INTEGRATED ENGINEERING PERFECTLY INTERLINKED

SIEMENS 828D is a latest model CNC. It is designed for horizontal/vertical all-purpose equipments.

Its 80-bit control reduces processing time and increases productivity. The 828D is easy to maintain and run, with its easy setup functions.



SIEMENS Technology

Shop Turn

- Dialogue-type programming, simple and convenient
- Effective specifications for small quantity batch production
- Step-by-step operation possible without knowledge of the DIN/ISO code



OPTION

3D Simulation

- 3D confirmation of the completed processing configuration of the NC program is possible.
- Offers standards for 2D simulation.
- Possible to confirm the simulation of the NC program during processing.



OPTION

Easy Extend

- Easy to install/uninstall an option (Ex : barfeeder and chip conveyor, etc.)
- Possible to install in one motion without revision of individual perimeters.
- A spate list is unnecessary as option items are indicated with letters.



SIEMENS Communication Function

Variable Communication Port

RJ 45 Ethernet

USB 2.0

Compact Flash Card



Easy input/output of a program is possible as a USB memory card, a CF memory card and LAN can all be used.

ISO Code Programming



If the ISO Dialect (G291) is ordered, JIS-based G-code programs can be used. (Standard)

SIEMENS Convenience Function

Easy Tool Measuring

- Easy calculation (automatic and manual) of the offset values of the installed equipment
- Automatic input of the measured offset values of equipment into the equipment list



Work Offset Measuring

- Supports the function of work offset calculation
- Automatic application of the measured work offset value as the activated work offset



Real Time PLC Monitoring

- Real time monitoring of PLC programs is possible. Supports the "search" and "cross reference" functions.
- Real time verification of I/O variables and PLC interface
- Input/change of the values of variables



Block Searching

- Program can be re-started from a particular location without editing the processing program.
- Provides safety to the user.



Alarm Log

- A maximum of 500 alarms can be stored.
- The entire alarm log can be stored as a data file in the I/O
- The overall alarm history can be checked through the alarm log.

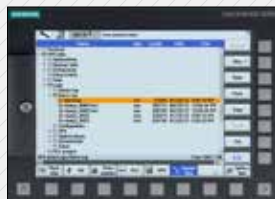

SIEMENS Easy Programming



Program Guide

Simple Program, High Productivity

- Use of cycle program minimizes program capacity.
- When cycle variables are input, graphic images are provided.
- Tool path and simulation of completed cycle program are available.
- Various configurations can be processed using cycles.



Engraving Cycle

Simple Letter Processing is Possible.

- Letters can be processed on products by establishing a plane and inputting letters.
- Letter size/angle/location/direction can be designated.
- Capital and small letters of English can be processed.

n6

L400 Series

User Convenience

Various Devices for User Convenience

Steady Rest

OPTION



For long parts, such as shafts, the steady rest increases rigidity and minimizes vibration.

When using the Programmable Hydraulic Steady Rest option, the position of the steady rest can be adjusted by the alignment pin connected to the turret. This option enhances the efficiency of the machining process.

Auto Q-Setter



Quick and accurate tool calibration can be done by contacting the tool tip with the sensor. This process is done easily with the use of M-Code and the calibration process takes roughly 30 seconds.

Tail Stock

❖ L400A/MA/C : MT#5 Built-In Tail Stock (Option)

The built-in tail stock ensures high accuracy even during heavy duty cutting and can be controlled automatically or manually.

L400A/MA/C

Taper : **MT#4**

Quill Dia. : **Ø100 (Ø3.9")**

Quill Travel : **130 mm (5.1")**

L400LC/MC/LMC

Taper : **MT#5** (Built-in)

Quill Dia. : **Ø150 (5.9")**

Quill Travel : **132 mm (5.2")**



Chuck Type Tail Stock

OPTION

When machining materials with a center hole and the use of tail stock is not possible, chuck type tail stock can be used to ensure stable machining.

Chuck Size : **10"** Spindle Speed : **3,000** rpm

Quill Dia. : **Ø75 (Ø2.9")**

SPECIFICATIONS

Standard & Optional

Spindle		L400A	L400MA
Main Spindle Hollow Chuck 3 Jaw	12"	●	●
	15"	○	○
	18" (Big Bore)	-	-
Main Spindle Solid Chuck 3 Jaw	21" (Big Bore)	-	-
	12"	☆	☆
	15"	☆	☆
Standard Soft Jaw (1set)		●	●
Chuck Clamp Foot Switch		●	●
2 Steps Hyd. Pressure Device		○	○
Spindle Inside Stopper		☆	☆
Main Spindle 5" Index		☆	-
C-axis (0.001")		-	●
Cs contouring function		-	●
Chuck Open/Close Confirmation Device		○(CE:●)	○(CE:●)
2 Steps Chuck Foot Switch		☆	☆
Turret			
Tool Holder		●	●
12 station Turret		●	●
Mill Turret	BMT	-	●
Straight Milling Head (Radial)	Collet Type, 1ea	-	-
Angular Milling Head (Axial)	Collet Type, 1ea	-	-
Straight Milling Head (Radial)	Adapter Type	-	-
Angular Milling Head (Axial)	Adapter Type	-	-
Boring Sleeve		●	●
Drill Socket		●	●
U-Drill Holder		○	○
U-Drill Holder Sleeve		○	○
Extension Holder	For Out-Dia	☆	-
Angle Head		-	☆
Tail Stock & Steady Rest			
Built-In Tail Stock		●	●
Programmable Tail Stock (MT #4)		●	●
Programmable Tail Stock (MT #5)		○	○
Manual Type Steady Rest		☆	☆
Manual Type Hyd. Steady Rest (SMW/Kan/Shinkang/Samchully)		☆	☆
Programmable Hyd. Steady Rest		○	○
Standard Dead Center		●	●
2 Steps Tail Stock Pressure System		☆	☆
Quill Forward/Reverse Confirmation Device		○(CE:●)	○(CE:●)
Tail Stock Foot Switch		○	○
Coolant & Air Blow			
Standard Coolant (Nozzle)		●	●
Chuck Coolant (Upper Chuck)		☆	☆
Gun Coolant		○	○
Through Spindle Coolant (Only for Special Chuck)		☆	☆
Thru Coolant for Live Tool		-	-
Chuck Air Blow(Upper Chuck)		○	○
Tail Stock Air Blow (Upper Tail Stock)		☆	☆
Turret Air Blow		☆	☆
Air Gun		○	○
Through Spindle Air Blow (Only for Special Chuck)		☆	☆
High Pressure Coolant	0.4Bar (5.8psi)	●	●
	6Bar (87psi)	○	○
	20Bar (290psi)	○	○
Power Coolant System (For Automation)		☆	☆
Coolant Chiller		☆	☆
Chip Disposal			
Coolant Tank	300 ℓ (79.3 gal)	●	●
	400 ℓ (105.7 gal)	-	-
Chip Conveyor (Hinge/Scraper)	Front (Right)	○	○
	Front (Rear)	-	-
Special Chip Conveyor (Drum Filter)		☆	☆
Chip Wagon	Standard (180 ℓ [47.5 gal])	○	○
	Swing (200 ℓ [52.8 gal])	○	○
	Large Swing (290 ℓ [76.6 gal])	○	○
	Large Size (330 ℓ [87.2 gal])	○	○
	Customized	☆	☆

● : Standard ○ : Option ☆ : Prior Consultation - : Non Applicable

Safety Device		L400A	L400MA
Total Splash Guard		●	●
Chuck hydraulic pressure maintenance interlock		○(CE:●)	○(CE:●)
Electric Device			
Call Light	1Color : ●	●	●
Call Light	2Color : ●●	○	○
Call Light	3Color : ●●●	○	○
Call Light & Buzzer	3Color : ●●● B	○	○
Electric Cabinet Light		○	○
Remote MPG		○	○
Workcounter	Digital	○	○
Totalcounter	Digital	○	○
Toolcounter	Digital	○	○
Multi-Tool counter	Digital	○	○
Electric Circuit Breaker		○	○
AVR (Auto Voltage Regulator)		☆	☆
Transformer	35KVA	○	-
	40KVA	-	-
	50KVA	-	○
	60KVA	-	-
Auto Power Off		○	○
Measurement			
Q-Setter		-	-
Automatic Q-Setter		●	●
Work Close Confirmation Device (Only for Special Chuck)	TACO	☆	☆
	SMC	☆	☆
Work Setter		☆	☆
Linear Scale	X Axis	○	○
	Z Axis	-	-
Coolant Level Sensor (Only for Chip Conveyor)		☆	☆
Environment			
Air Conditioner	FANUC	○	○
	SIEMENS	-	●
Oil Mist Collector		☆	☆
Oil Skimmer (Only for Chip Conveyor)		○	○
MQL (Minimal Quantity Lubrication)		☆	☆
Fixture & Automation			
Auto Door	High Speed	○	○
Auto Shutter (Only for Automatic System)		-	-
Sub Operation Pannel		☆	☆
Bar Feeder Interface		○	○
Bar Feeder (FEDEK)		☆	☆
Extra M-Code 4ea		○	○
Automation Interface		☆	☆
I/O Extension (IN & OUT)	16 Contact	○	○
	32 Contact	○	○
Parts Catcher		-	-
Turret Work Pusher (For Automation)		☆	☆
Hyd. Device			
Standard Hyd. Cylinder	Hollow	●	●
Standard Hyd. Unit	60bar(870psi) / 13 ℓ (3.4gal)	-	-
	60bar(870psi) / 20 ℓ (5.3gal)	●	●
S/W			
Machine Guidance (HW-MCG)		☆	☆
Energy Saving System (HW-ESS)		●	●
Tool Monitoring (HW-TM)		○	○
DNC software (HW-eDNC)		○	○
Machine Monitoring System (HW-MMS)		☆	☆
Conversational program (HW-DPRO)		○	○
ETC			
Tool Box		●	●
Customized Color	Need Munsel No.	☆	☆
CAD & CAM		☆	☆

Prior consultation is required when applying spindle contouring control for gear driven spindle. Specifications are subject to change without notice for improvement.

SPECIFICATIONS

Standard & Optional

Spindle		L400C/LC	L400MC/LMC
Main Spindle Hollow Chuck 3 Jaw	12"	-	-
	15"	●	●
	18" (Big Bore)	○	○
Main Spindle Solid Chuck 3 Jaw	21" (Big Bore)	○	○
	12"	-	-
Standard Soft Jaw (1set)	15"	☆	☆
Chuck Clamp Foot Switch		●	●
2 Steps Hyd. Pressure Device		○	○
Spindle Inside Stopper		☆	☆
Main Spindle 5° Index		☆	-
C-axis (0.001°)		-	●
Cs contouring function		-	☆
Chuck Open/Close Confirmation Device		○ (CE: ●)	○ (CE: ●)
2 Steps Chuck Foot Switch		☆	☆
Turret			
Tool Holder		●	●
12 station Turret		-	●
10 station Turret		●	-
Mill Turret	BMT	-	●
Straight Milling Head (Radial)	Collet Type, 1ea	-	-
Angular Milling Head (Axial)	Collet Type, 1ea	-	-
Straight Milling Head (Radial)	Adapter Type	-	-
Angular Milling Head (Axial)	Adapter Type	-	-
Boring Sleeve		●	●
Drill Socket		●	●
U-Drill Holder		○	○
U-Drill Holder Sleeve		○	○
Extension Holder	For Out-Dia	☆	-
Angle Head		-	☆
Tail Stock & Steady Rest			
Built-In Tail Stock		●	●
Programmable Tail Stock (MT #4)		● / -	-
Programmable Tail Stock (MT #5)		○ / ●	●
Manual Type Steady Rest		☆	☆
Manual Type Hyd. Steady Rest (SMW/Kan/Shinkang/Samchully)		☆	☆
Programmable Hyd. Steady Rest		○	○
Standard Dead Center		●	●
2 Steps Tail Stock Pressure System		☆	☆
Quill Forward/Reverse Confirmation Device		○ (CE: ●)	○ (CE: ●)
Tail Stock Foot Switch		○	○
Coolant & Air Blow			
Standard Coolant (Nozzle)		●	●
Chuck Coolant (Upper Chuck)		☆	☆
Gun Coolant		○	○
Through Spindle Coolant (Only for Special Chuck)		☆	☆
Thru Coolant for Live Tool		-	-
Chuck Air Blow(Upper Chuck)		○	○
Tail Stock Air Blow (Upper Tail Stock)		☆	☆
Turret Air Blow		☆	☆
Air Gun		○	○
Through Spindle Air Blow (Only for Special Chuck)		☆	☆
High Pressure Coolant	0.4Bar (5.8psi)	●	●
	6Bar (87psi)	○	○
	20Bar (290psi)	○	○
Power Coolant System (For Automation)		☆	☆
Coolant Chiller		☆	☆
Chip Disposal			
Coolant Tank	300 ℓ (79.3 gal)	● / -	● / -
	400 ℓ (105.7 gal)	- / ●	- / ●
Chip Conveyor (Hinge/Scraper)	Front (Right)	○	○
	Front (Rear)	-	-
Special Chip Conveyor (Drum Filter)		☆	☆
Chip Wagon	Standard (180 ℓ [47.5 gal])	○	○
	Swing (200 ℓ [52.8 gal])	○	○
	Large Swing (290 ℓ [76.6 gal])	○	○
	Large Size (330 ℓ [87.2 gal])	○	○
	Customized	☆	☆

Prior consultation is required when applying spindle contouring control for gear driven spindle. Specifications are subject to change without notice for improvement.

● : Standard ○ : Option ☆ : Prior Consultation - : Non Applicable

Safety Device		L400C/LC	L400MC/LMC
Total Splash Guard		●	●
Chuck hydraulic pressure maintenance interlock		○ (CE: ●)	○ (CE: ●)
Electric Device			
Call Light	1Color : ●	●	●
Call Light	2Color : ● ●	○	○
Call Light	3Color : ● ● ●	○	○
Call Light & Buzzer	3Color : ● ● ● B	○	○
Electric Cabinet Light		○	○
Remote MPG		○	○
Workcounter	Digital	○	○
Totalcounter	Digital	○	○
Toolcounter	Digital	○	○
Multi-Tool counter	Digital	○	○
Electric Circuit Breaker		○	○
AVR (Auto Voltage Regulator)		☆	☆
Transformer	35kVA	-	-
	40kVA	○ / -	-
	50kVA	- / ○	-
	60kVA	-	○
Auto Power Off		○	○
Measurement			
Q-Setter		-	-
Automatic Q-Setter		●	●
Work Close Confirmation Device (Only for Special Chuck)	TACO	☆	☆
	SMC	☆	☆
Work Setter		☆	☆
Linear Scale	X Axis	○	○
	Z Axis	-	-
Coolant Level Sensor (Only for Chip Conveyor)		☆	☆
Environment			
Air Conditioner	FANUC	○	○
	SIEMENS	●	●
Oil Mist Collector		☆	☆
Oil Skimmer (Only for Chip Conveyor)		○	○
MQL (Minimal Quantity Lubrication)		☆	☆
Fixture & Automation			
Auto Door	High Speed	○	○
Auto Shutter (Only for Automatic System)		-	-
Sub Operation Pannel		☆	☆
Bar Feeder Interface		○	○
Bar Feeder (FEDEK)		☆	☆
Extra M-Code 4ea		○	○
Automation Interface		☆	☆
I/O Extension (IN & OUT)	16 Contact	○	○
	32 Contact	○	○
Parts Catcher		-	-
Turret Work Pusher (For Automation)		☆	☆
Hyd. Device			
Standard Hyd. Cylinder	Hollow	●	●
	60bar(870psi) / 13 ℓ (3.4gal)	-	-
Standard Hyd. Unit	60bar(870psi) / 20 ℓ (5.3gal)	●	●
S/W			
Machine Guidance (HW-MCG)		☆	☆
Energy Saving System (HW-ESS)		●	●
Tool Monitoring (HW-TM)		○	○
DNC software (HW-eDNC)		○	○
Machine Monitoring System (HW-MMS)		☆	☆
Conversational program (HW-DPRO)		○	○
ETC			
Tool Box		●	●
Customized Color	Need Munsel No.	☆	☆
CAD & CAM		☆	☆

SPECIFICATIONS

External Dimensions

unit : mm(in)

L400A/MA/C/MC (SLUB5 Steady Rest Application)

 : Expand Type Coolant Tank

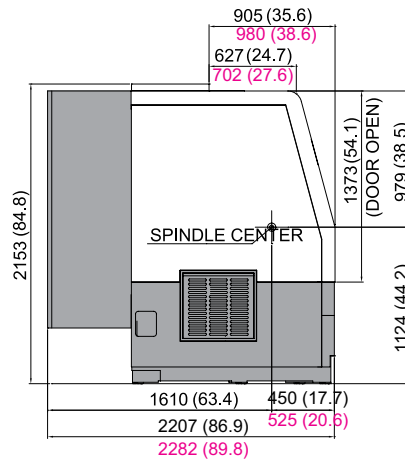
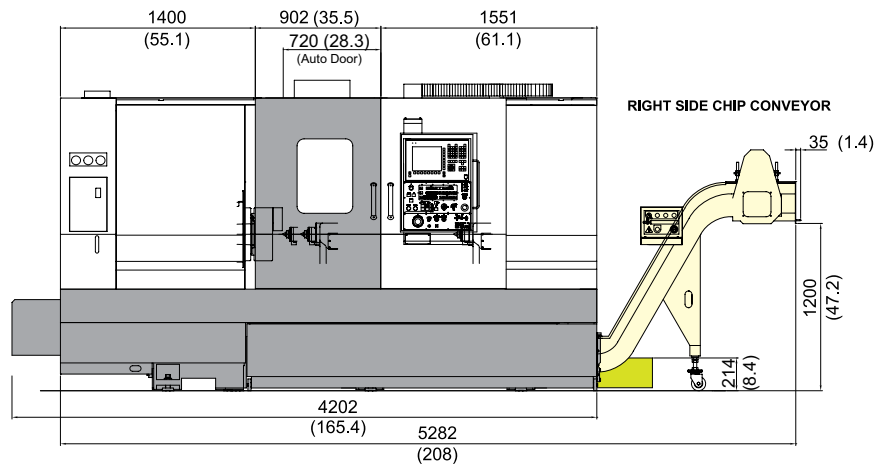
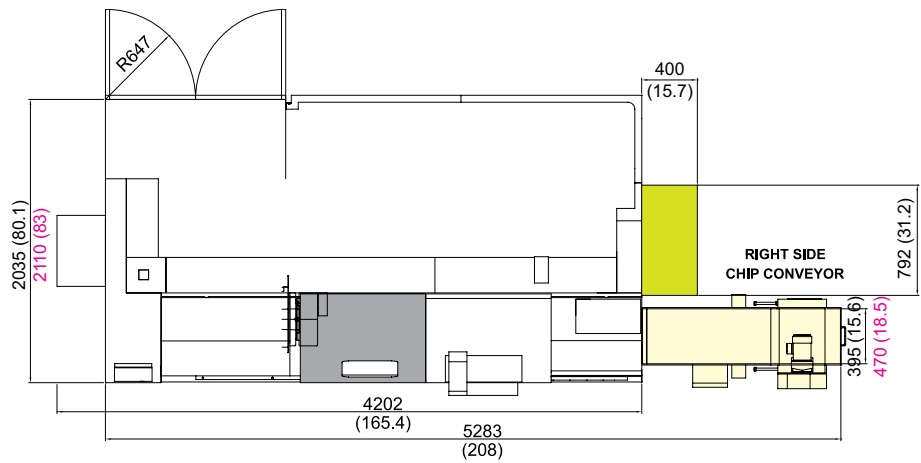

SPECIFICATIONS

External Dimensions

unit : mm(in)

L400LC/LMC (SLUB5 Steady Rest Application)

 : Expand Type Coolant Tank

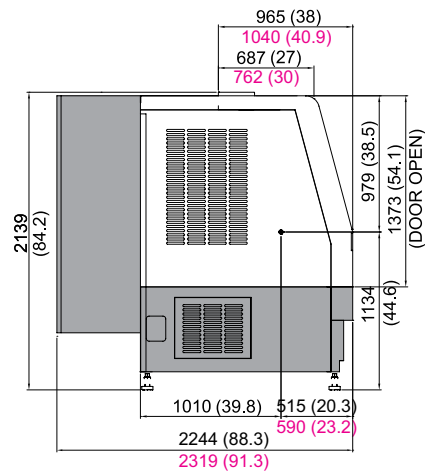
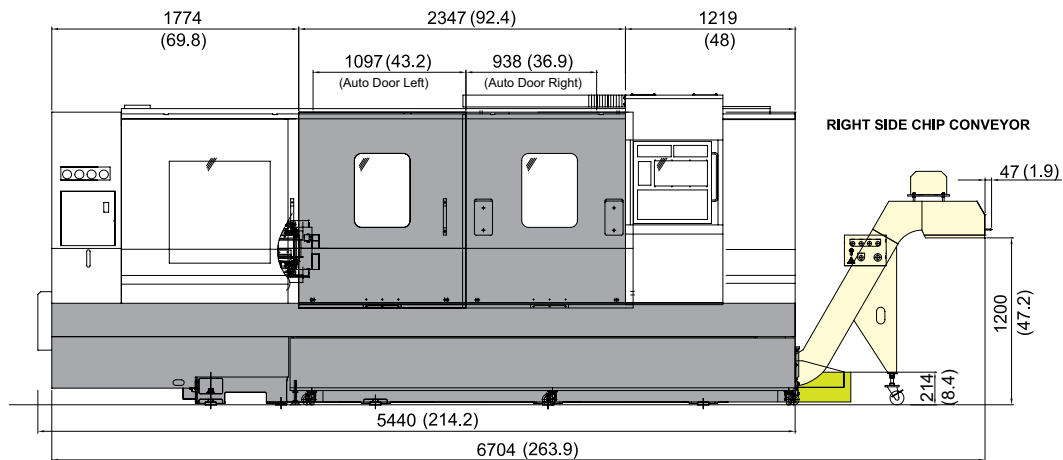
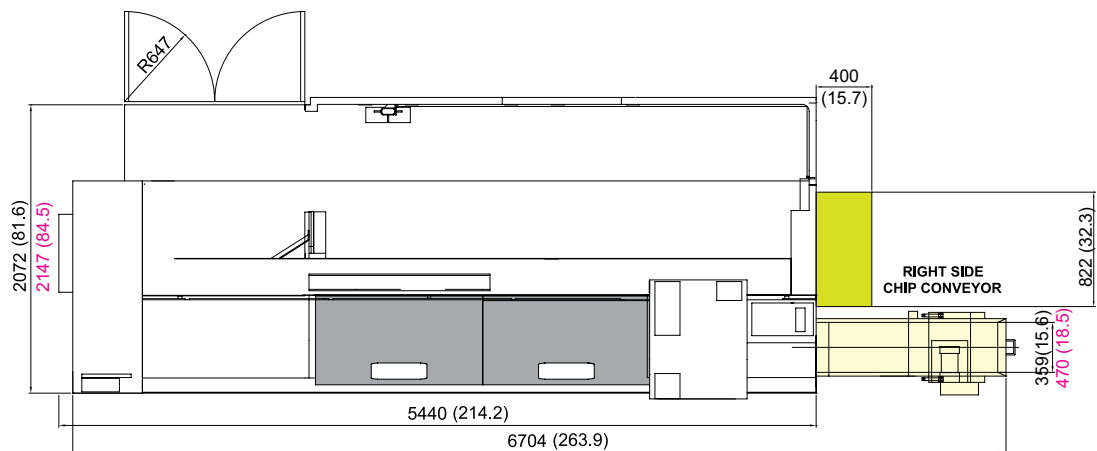

SPECIFICATIONS

Tooling System

unit : mm(in)

L400A

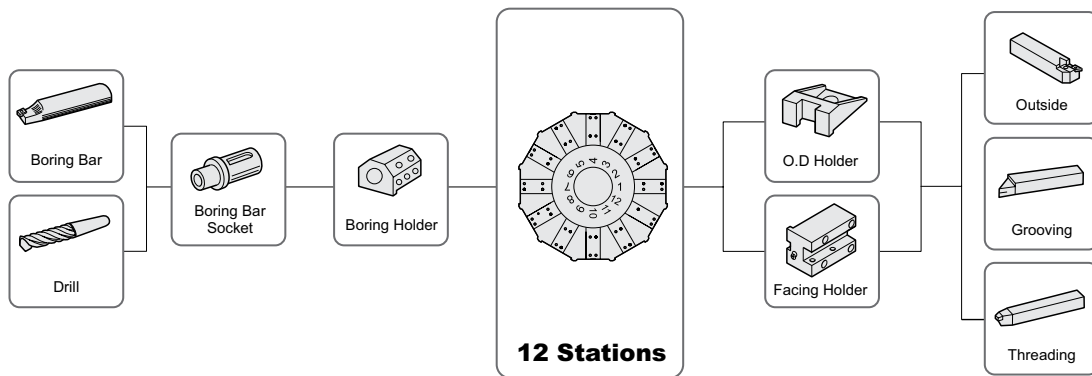

Tooling Parts Detail

ITEM			L400A	
			mm Unit	inch Unit
Turning Holder	O.D Holder	Right/Left	1	1
	Facing Holder		1	1
Boring Holder	I.D Holder	Single	5	5
		C-Clip	Opt	Opt
	U-Drill Holder	Tool Holder	Opt	Opt
Driven Holder	Straight Mill Holder	Standard	-	-
	Angular Mill Holder	Standard	-	-
Socket	Boring	Ø16 (5/8")	1	1
		Ø20 (3/4")	1	1
		Ø25 (1")	1	1
		Ø32 (1 1/4")	1	1
		Ø40 (1 1/2")	1	1
	Drill	MT 2	-	-
		MT 3	1	1
		MT 4	-	-
	C-CLIP Boring (Opt.)	Ø16 (5/8")	1	1
		Ø20 (3/4")	1	1
		Ø25 (1")	1	1
		Ø32 (1 1/4")	1	1
		Ø40 (1 1/2")	1	1
	ER Collet		-	-

Specifications are subject to change without notice for improvement.

SPECIFICATIONS

Tooling System

unit : mm(in)

L400C/LC

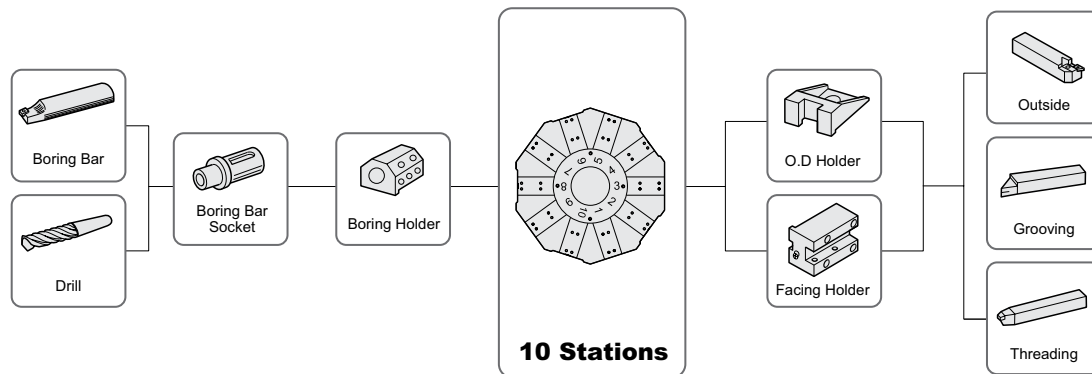

Tooling Parts Detail

ITEM			L400C/LC	
			mm Unit	inch Unit
Turning Holder	O.D Holder	Right/Left	1	1
	Facing Holder		1	1
Boring Holder	I.D Holder	Single	4	4
		C-Clip	Opt	Opt
	U-Drill Holder	Tool Holder	Opt	Opt
Driven Holder	Straight Mill Holder	Standard	-	-
	Angular Mill Holder	Standard	-	-
Socket	Boring	Ø16 (5/8")	1	1
		Ø20 (3/4")	1	1
		Ø25 (1")	1	1
		Ø32 (1 1/4")	1	1
		Ø40 (1 1/2")	1	1
	Drill	MT 2	-	-
		MT 3	1	1
		MT 4	-	-
	C-CLIP Boring (Opt.)	Ø16 (5/8")	1	1
		Ø20 (3/4")	1	1
		Ø25 (1")	1	1
		Ø32 (1 1/4")	1	1
		Ø40 (1 1/2")	1	1
	ER Collet			-

SPECIFICATIONS

Tooling System

unit : mm(in)

L400MA/MC/LMC

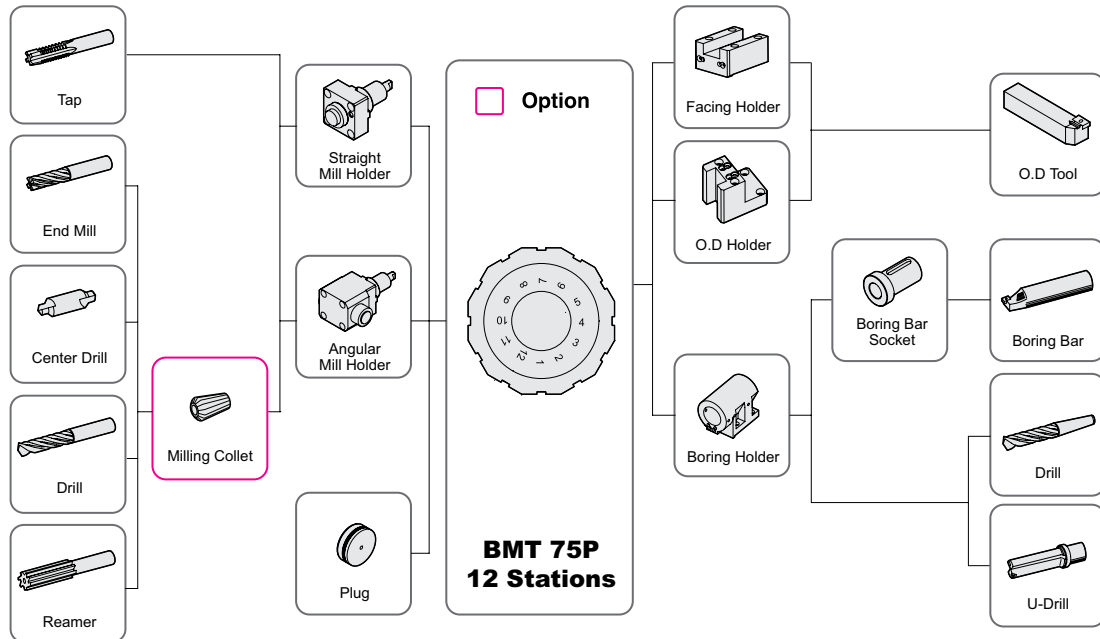

Tooling Parts Detail

ITEM			L400MA		L400MC		L400LMC		
			mm Unit	inch Unit	mm Unit	inch Unit	mm Unit	inch Unit	
Turning Holder	O.D Holder	Right/Left	2	2	2	2	2	1	
	Facing Holder		2	2	2	2	2	1	
Boring Holder	I.D Holder	Single	4	4	4	4	4	4	
		C-Clip	-	-	Opt	Opt	Opt	Opt	
	U-Drill Holder	Tool Holder	Opt	Opt	Opt	Opt	Opt	Opt	
Driven Holder	Straight Mill Holder	Standard	1	1	1	1	1	1	
	Angular Mill Holder	Standard	1	1	1	1	1	1	
Socket	Boring	Ø16 (5/8")	1	1	-	-	-	-	
		Ø20 (3/4")	1	1	1	1	1	1	
		Ø25 (1")	1	1	1	1	1	1	
		Ø32 (1 1/4")	1	1	1	1	1	1	
		Ø40 (1 1/2")	1	1	1	1	1	1	
		Ø50 (2")	-	-	1	1	1	1	
	Drill	MT 2		Opt	Opt	-	-	-	-
		MT 3		1	1	1	1	1	1
		MT 4		Opt	Opt	Opt	Opt	Opt	Opt
	ER Collet		Opt	Opt	Opt	Opt	Opt	Opt	

Specifications are subject to change without notice for improvement.

SPECIFICATIONS

Interference

unit : mm(in)

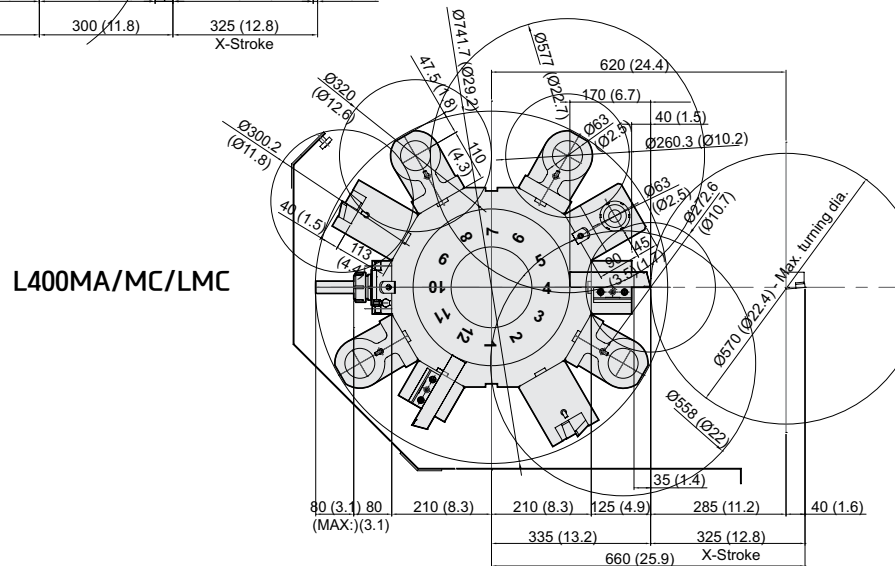
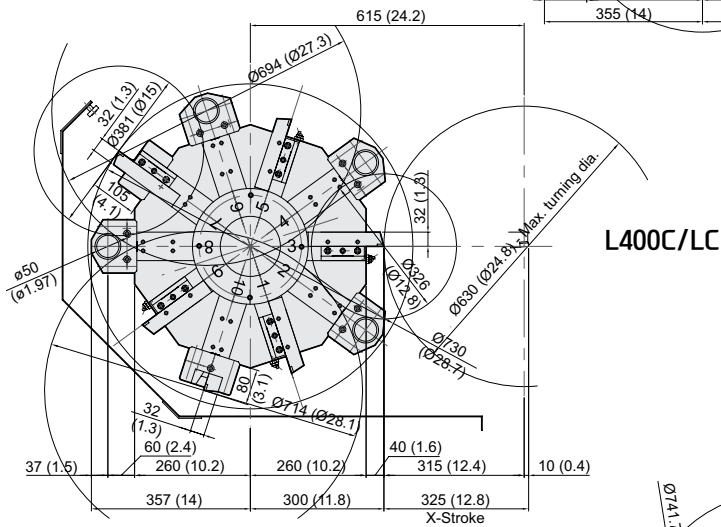
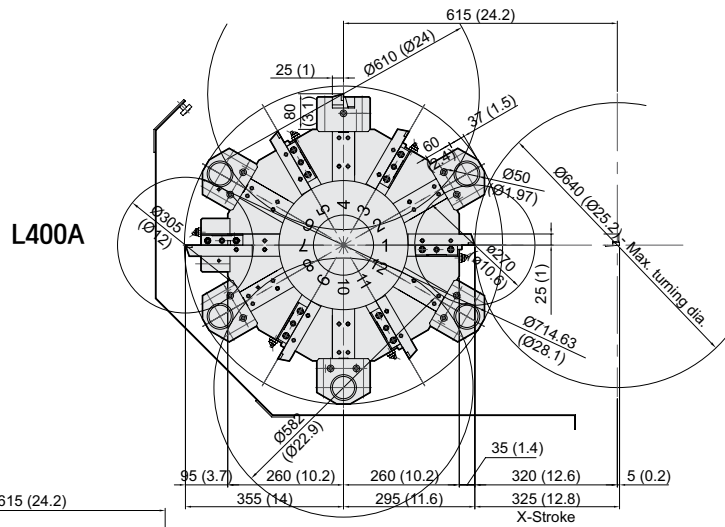

SPECIFICATIONS

Interference

unit : mm(in)

L400A (■ : MT#5)

OD Turning Holder

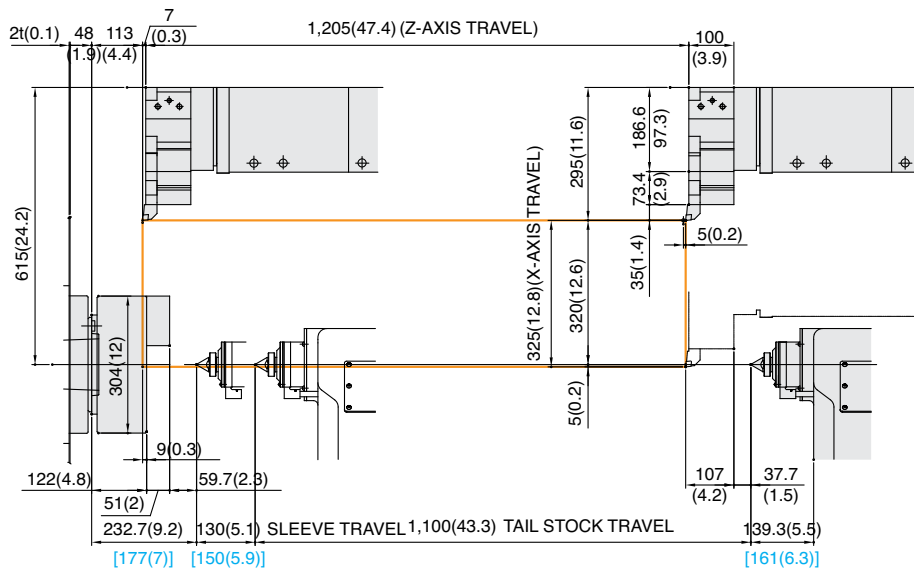

Boring Bar Holder

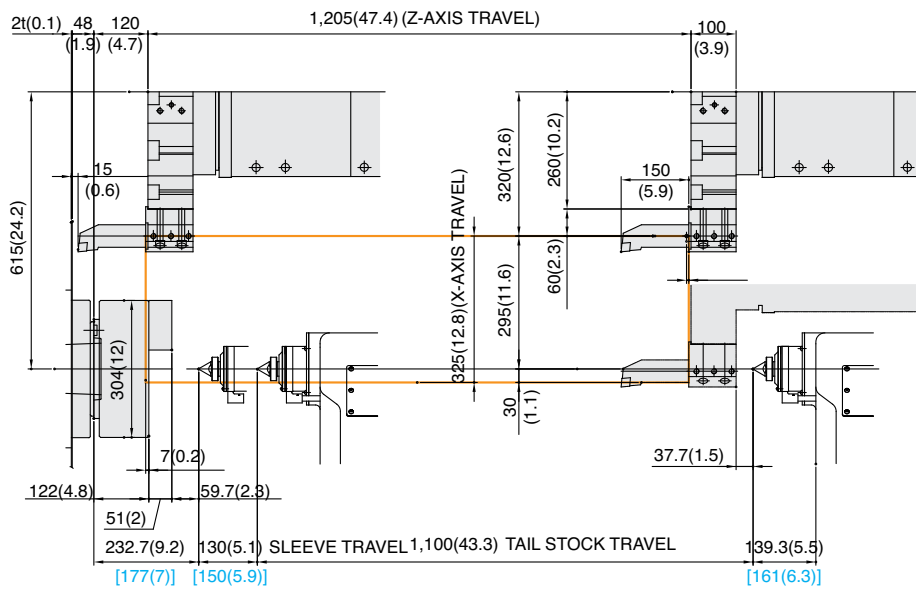

SPECIFICATIONS

Tooling Travel Range

unit : mm(in)

L400C (■ : MT#5)

L400LC

OD Turning Holder

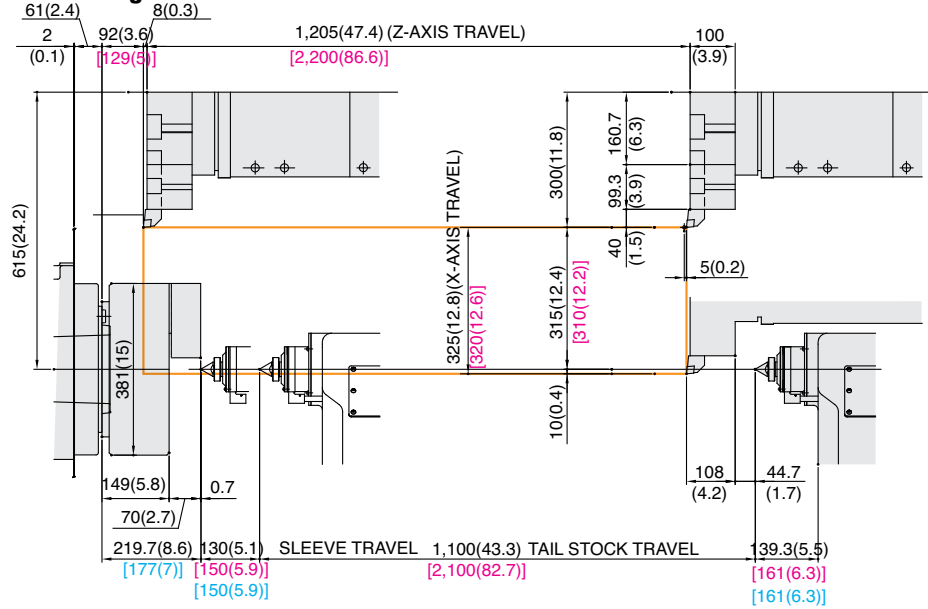

Boring Bar Holder

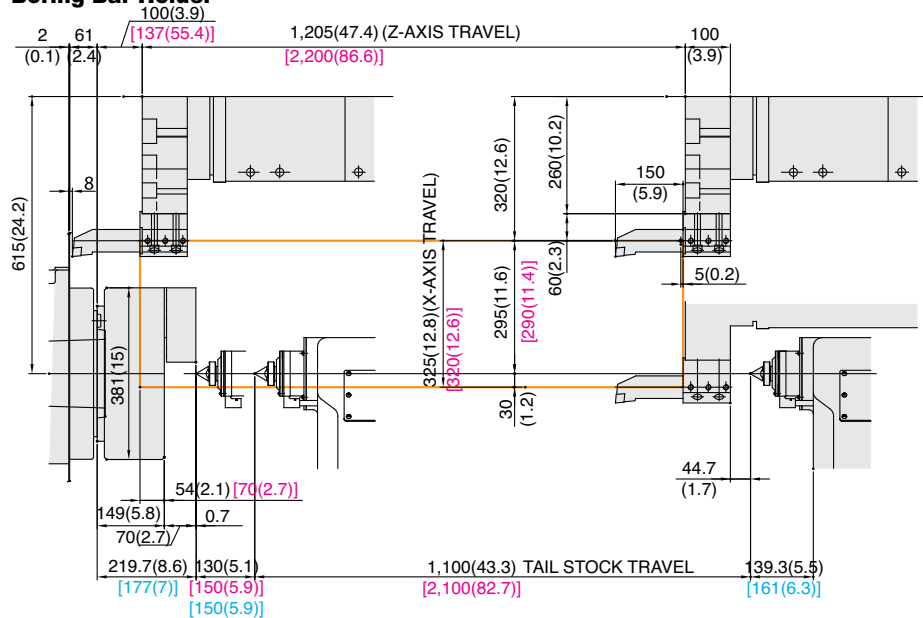

SPECIFICATIONS

Interference

unit : mm(in)

L400MA/MC {Big Bore} (■ : MT#5)
L400LMC {Big Bore}

OD Turning Holder

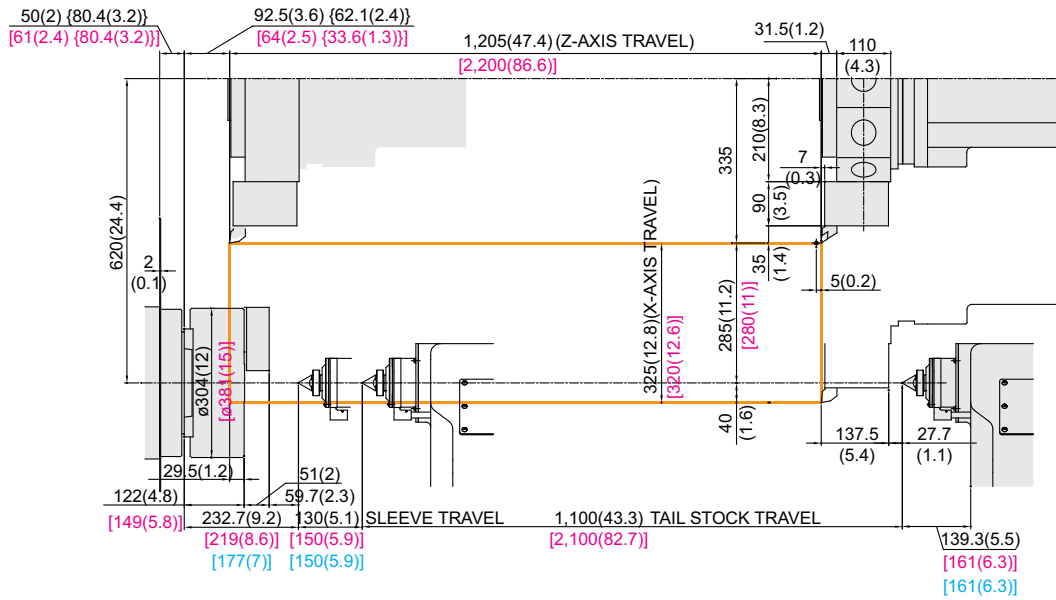

Boring Bar Holder

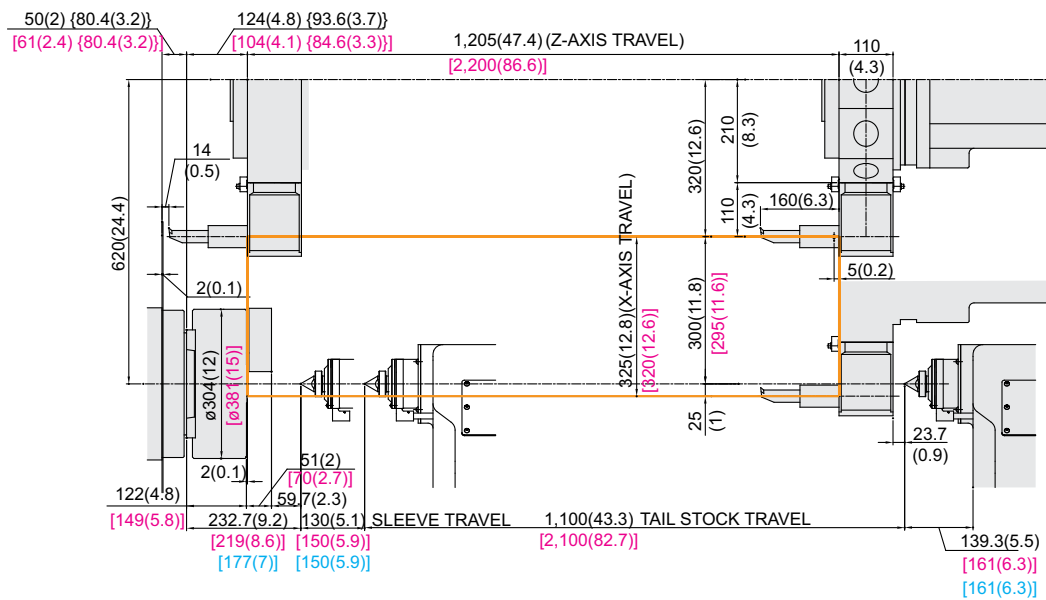

SPECIFICATIONS

Tooling Travel Range

unit : mm(in)

L400MA/MC {Big Bore} (■ : MT#5)

L400LMC {Big Bore}

Straight Milling Head

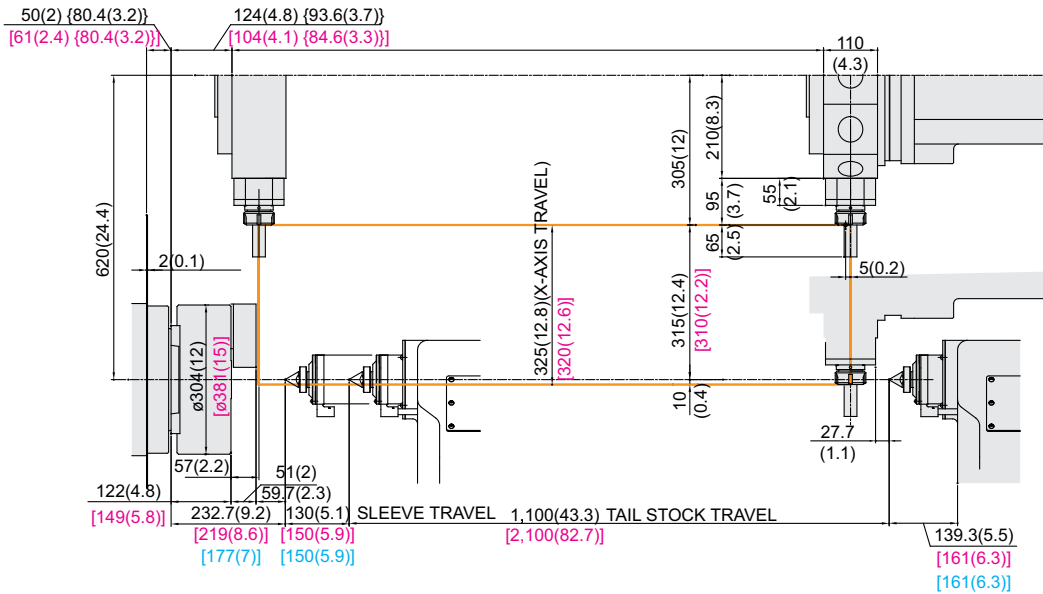

Angular Milling Head

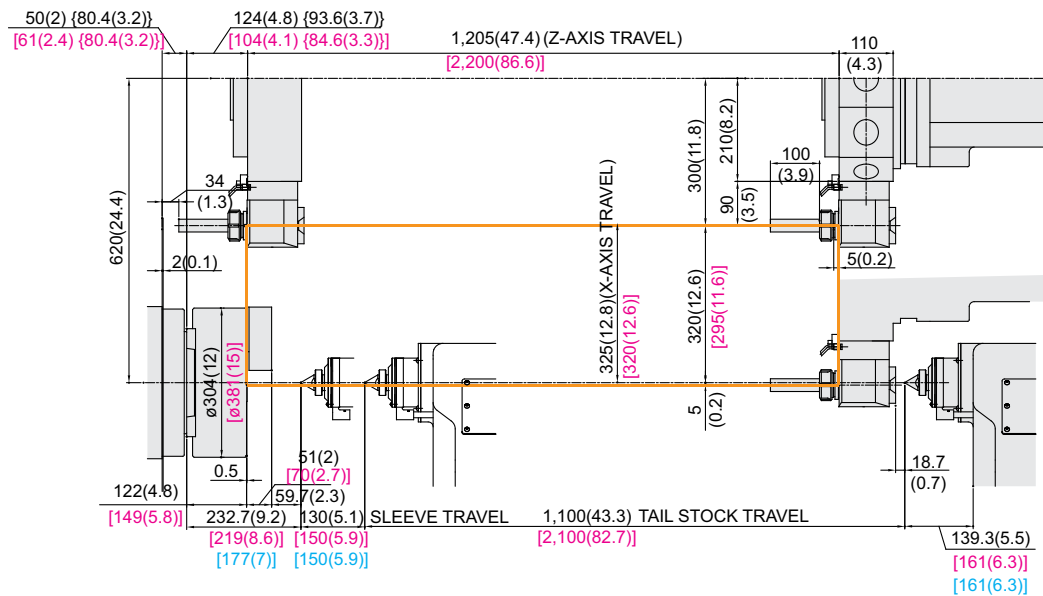

SPECIFICATIONS

Specifications

[] : Option

ITEM			L400A	L400MA
CAPACITY	Swing Over the Bed	mm(in)	Ø780 (30.7")	
	Swing Over the Carriage	mm(in)	Ø535 (21.1")	
	Max. Turning Dia.	mm(in)	Ø640 (25.2")	Ø570 (22.4")
	Max. Turning Length	mm(in)	1,180 (46.5")	
	Bar Capacity	mm(in)	Ø90 (3.5")	
SPINDLE	Chuck Size	inch	12"	
	Spindle Bore	mm(in)	Ø104 (4.1")	
	Spindle Speed (rpm)	r/min	3,000	3,000 [3,000]
	Motor (Max/Cont.)	kW(HP)	26/22 (34.9/29.5)	30/20 (40.2/26.8) [32/27 (42.9/36.2)]
	Torque (Max/Cont.)	N·m(lbf·ft)	1,325/1,120 (977.3/826.1)	797/585 (587.8/431.5) [786.2/663.4 (579.9/489.3)]
	Spindle Type	-	BELT+2STEP GEAR	BELT
	Spindle Nose	-	A2-8	
	C-axis Indexing	deg	-	0.001°
FEED	Travel (X/Z)	mm(in)	325/1,205 (12.8"/47.4")	
	Rapid Traverse Rate (X/Z)	m/min(ipm)	20/25 (787/984)	
	Slide Type	-	BOX GUIDE	
TURRET	No. of Tools	EA	12	
	Tool Size	OD	□ 25 (1")	
		ID	Ø50 (2")	
	Indexing Time	sec/step	0.2	
LIVE TOOL	Motor (Max/Cont.)	kW(HP)	-	7.5/5.5 (10/7.4) [7.5/6.3 (10/8.4)]
	Milling Tool Speed (rpm)	r/min	-	4,000 [4,000]
	Torque (Max/Cont.)	N·m(lbf·ft)	-	44.7/35 (33/25.8) [71.6/60 (52.8/44.3)]
	Collet Size	mm(in)	-	Ø26(1") (ER40)
	Type	-	-	BMT75P
TAIL STOCK	Taper	-	MT#4 (Built-in) [MT#5 (Built-in)]	
	Quill Dia.	mm(in)	Ø100 (3.9") [Ø150 (5.9")]	
	Quill Travel	mm(in)	130 (5.1") [132 (5.2")]	
	Travel	mm(in)	1,100 (43.3")	
TANK CAPACITY	Coolant Tank	ℓ (gal)	300 (79.3)	
	Lubricating Tank	ℓ (gal)	2 (0.5)	
POWER SUPPLY	Electric Power Supply	kVA	29	40
	Thickness of Power Cable	Sq	Over 50	
	Voltage	V/Hz	220/60 (200/50*)	
MACHINE	Floor Space (L×W)	mm(in)	4,202×2,207 (165.4"×86.9")	
	Height	mm(in)	2,153 (84.8")	
	Weight	kg(lb)	8,500 (18,739)	
PC	Controller	-	H/W F i Series [F 32i-A]	F 32i-A [H/W F i Series] [S 828D]

*) Using 50Hz voltage instead of 60Hz may lower the output of motors. (excluding servo motors and inverter motors)

Prior consultation is required when applying spindle contouring control for gear driven spindle.

Specifications are subject to change without notice for improvement.

SPECIFICATIONS

Specifications

[] : Option

ITEM		L400C	L400LC	
CAPACITY	Swing Over the Bed	mm(in)	Ø780 (30.7")	
	Swing Over the Carriage	mm(in)	Ø535 (21.1")	
	Max. Turning Dia.	mm(in)	Ø630 (24.8")	
	Max. Turning Length	mm(in)	1,170 (46.1")	
	Bar Capacity	mm(in)	Ø117 (4.6") [Big Bore : Ø165.5 (6.5")]	
SPINDLE	Chuck Size	inch	15" [Big Bore : 18"/21"]	
	Spindle Bore	mm(in)	Ø130 (5.1") [[Big Bore : Ø181(7.1")]	
	Spindle Speed (rpm)	r/min	2,000 [Big Bore : 1,500] [2,000]	
	Motor (Max/Cont.)	kW(HP)	26/22 (34.9/29.5) [37/30 (49.6/40.2)] [26.4/22 (35.4/29.5)]	
	Torque (Max/Cont.)	N·m(lbf·ft)	1,753/1,483 (1,292.9/1,093.8) [2,705/2,194 (1,995.1/1,618.2)] [1,782/1,485 (1,314.3/1,095.3)]	
	Spindle Type	-	BELT+2STEP GEAR	
	Spindle Nose	-	A2-11 [Big Bore : A2-15]	
	C-axis Indexing	deg	-	
	Travel (X/Z)	mm(in)	325/1,205 (12.8"/47.4")	
FEED	Rapid Traverse Rate (X/Z)	m/min(ipm)	20/25 (787/984)	
	Slide Type	-	BOX GUIDE	
	Travel (X/Z)	mm(in)	320/2,200 (12.6"/86.6")	
TURRET	No. of Tools	EA	10	
	Tool Size	OD	mm(in)	□ 32 (1.2")
		ID	mm(in)	Ø50 (2")
	Indexing Time	sec/step		0.2
LIVE TOOL	Motor (Max/Cont.)	kW(HP)	-	
	Milling Tool Speed (rpm)	r/min	-	
	Torque (Max/Cont.)	N·m(lbf·ft)	-	
	Collet Size	mm(in)	-	
	Type	-	-	
TAIL STOCK	Taper	-	MT#4 (Built-in) [MT#5 (Built-in)]	
	Quill Dia.	mm(in)	Ø100 (3.9") [Ø150 (5.9")]	
	Quill Travel	mm(in)	130 (5.1") [132 (5.2")]	
	Travel	mm(in)	1,100 (43.3")	
TANK CAPACITY	Coolant Tank	ℓ (gal)	300 (79.3)	
	Lubricating Tank	ℓ (gal)	2 (0.5)	
POWER SUPPLY	Electric Power Supply	kVA	33	
	Thickness of Power Cable	Sq	Over 50	
	Voltage	V/Hz	220/60 (200/50*)	
MACHINE	Floor Space (L×W)	mm(in)	4,202×2,207 (165.4"×86.9")	
	Height	mm(in)	2,153 (84.8")	
	Weight	kg(lb)	8,500 (18,739)	
PC	Controller	-	H/W F i Series [F 32i-A] [S 828D]	

*) Using 50Hz voltage instead of 60Hz may lower the output of motors. (excluding servo motors and inverter motors)

Prior consultation is required when applying spindle contouring control for gear driven spindle.

Specifications are subject to change without notice for improvement.

SPECIFICATIONS

Specifications

[] : Option

ITEM			L400MC	L400LMC
CAPACITY	Swing Over the Bed	mm(in)	Ø780 (30.7")	Ø725 (28.5")
	Swing Over the Carriage	mm(in)	Ø535 (21.1")	
	Max. Turning Dia.	mm(in)	Ø560 (22")	
	Max. Turning Length	mm(in)	1,180 (46.5")	2,100 (82.7")
	Bar Capacity	mm(in)	Ø117 (4.6") [Big Bore : Ø165.5 (6.5")]	
SPINDLE	Chuck Size	inch	15" [Big Bore : 18"/21"]	
	Spindle Bore	mm(in)	Ø130 (5.1") [[Big Bore : Ø181(7.1")]	
	Spindle Speed (rpm)	r/min	2,000 [Big Bore : 1,500] [2,000]	
	Motor (Max/Cont.)	kW(HP)	37/30 (49.6/40.2) [37/30 (49.6/40.2)] [37.2/31(49.9/41.6)]	
	Torque (Max/Cont.)	N·m(lbf·ft)	3,073/2,490 (2,266.5/1,836.5) [2,705/2,194 (1,995.1/1,618.2)] [3,090/2,579 (2,279/1,902.2)]	
	Spindle Type	-	BELT+2STEP GEAR(GEARLESS)	
	Spindle Nose	-	A2-11 [Big Bore : A2-15]	
	C-axis Indexing	deg	0.001°	
FEED	Travel (X/Z)	mm(in)	320/1,200(12.6"/47.2")	320/2,200(12.6"/86.6")
	Rapid Traverse Rate (X/Z)	m/min(ipm)	20/25 (787/984)	20/20 (787/787)
	Slide Type	-	BOX GUIDE	
TURRET	No. of Tools	EA	12	
	Tool Size	OD	□ 32 (1.2")	
		ID	Ø63 (2.5")	
	Indexing Time	sec/step	0.2	
LIVE TOOL	Motor (Max/Cont.)	kW(HP)	7.5/5.5 (10/7.4) [7.5/6.3 (10/8.4)]	
	Milling Tool Speed (rpm)	r/min	4,000 [4,000]	
	Torque (Max/Cont.)	N·m(lbf·ft)	44.7/35 (33/25.8) [71.6/60 (52.8/44.3)]	
	Collet Size	mm(in)	Ø26(1") (ER40)	
	Type	-	BMT75P	
TAIL STOCK	Taper	-	MT#5 (Built-in)	
	Quill Dia.	mm(in)	Ø150 (5.9")	
	Quill Travel	mm(in)	132 (5.2")	
	Travel	mm(in)	1,100 (43.3")	2,100 (82.7")
TANK CAPACITY	Coolant Tank	ℓ (gal)	300 (79.3)	400 (105.7)
	Lubricating Tank	ℓ (gal)	2 (0.5)	4 (1.1)
POWER SUPPLY	Electric Power Supply	kVA	46	
	Thickness of Power Cable	Sq	Over 50	
	Voltage	V/Hz	220/60 (200/50*)	
MACHINE	Floor Space (L×W)	mm(in)	4,202×2,207 (165.4"×86.9")	5,440×2,244 (214.2"×88.3")
	Height	mm(in)	2,153 (84.8")	2,139 (84.2")
	Weight	kg(lb)	8,500 (18,739)	11,000 (24,250)
PC	Controller	-	F 32i-B [H/W F i Series] [S 828D]	

❖ L400MC/LMC models recommended to use Gearless Type when contouring control is needed.

*) Using 50Hz voltage instead of 60Hz may lower the output of motors. (excluding servo motors and inverter motors)

Prior consultation is required when applying spindle contouring control for gear driven spindle.

Specifications are subject to change without notice for improvement.

CONTROLLER

SIEMENS 828D (L400MC/LMC)

Control function	
Max. configuration of axis	3 axis(MS / SY exception) 4 axis(MS / SY machine only)
Max. configuration of axis and sp.	6 axis(MS / SY exception) 8 axis(MS / SY machine only)
Least Command/input	0.0001mm / 0.00001inch
Feed function	
Feedrate Override	0 - 120%
Rapid Traverse Override	F1, 5, 25/50, 100%
Acceleration with jerk limitation	
Programmable acceleration	
Follow-up mode	
Measuring system 1 and 2, selectable	
Separate path feed for corners and chamfers	
Travel to fixed stop	
Spindle function	
Spindle Override	50% - 120%
Spindle Orientation	
Spindle Speed Limitation	
Rigid Tapping	
Interpolation function	
Linear interpolation axis	Max. 4 axis
Circle via center point and end point	
Circle via interpolation point	
Helical interpolation	
Universal interpolator NURBS (non-uniform rational B splines)	
Continuous-path mode with programmable rounding clearance	
Tool function	
Tool Radius Comp.	
Zero Offset (G54, G55, G56, G57, G58, G59)	100 EA
Programmable Zero Offset	
Tool management	
Display	
CRT / MDI	10.4" Color LCD
SCREEN SAVER	None
Manual Operation	
Manual Handle/Jog Feed	
Reposition	
Reference Approach	Ref 1, 2 Approach
Spindle Control	Start, Stop, Rev, Jog, Ort.
Auto Operation	
Single Block	
Feed Hold	
Optional Block Skip	
Machine Lock	
Dry Run	
Simulation	(2 dimensional)
Diagnosis function	
Alarm Display	
Spindle Load Meter/RPM Meter (monitor)	
PLC status/LAD display	

Program function	
Part Program Storage Length	3MB (MS / SY exception) PPU26x.x 5MB (MS / SY machine only) PPU28x.x
Program Name	23 digit
Subroutine Call	(7 level)
Absolute/Incremental Command	G90 - G91
Scaling, ROT	
Inch / Metric Conversion	
Conversational Cycle Program	(22 Machine)
Block Search	
Variable Program (Macro)	
Read / Write System Variable	
BackGround Editing	
Miscellaneous Functions	M - Code
Label Skip	
Program Stop/End	M00, M01, M02, M30
Lookahead, Jerk LimitationFeed & forward control	
ISO Dialect Interpreter(G291) (Fanuc Program exe)	
Maximum number of tools/cuttings	128/256 (MS / SY exception) PPU26x.x 256/512 (MS / SY machine only) PPU28x.x
Number of levels for skip blocks 1	
Protection Function	
Emergency Stop	
Over Travel	Soft Limit & Hard O.T
Contour Monitoring	
Program Protection	
Automation Support Fun.	
Actual Speed Display(Monitor)	
Tool Life Management	(Time, Parts)
Work Count Function	(Internal)
Language Function	
	(6EA) Chinese Traditional, Czech, Danish, Dutch, Finnish, Hungarian, Japanese, Korean, Polish, Russian, Swedish, Portuguese, Turkish
Two Language Switchable	
Data Transfer	
RS 232C I/F / Ethernet	
USB Memory Stick & CF Card	
Option	
Shop Turn	
3D Simulation	
DRF offset	
Teach -in	
Number of levels for skip blocks 8	
TRACYL (Cylinder interpolation)	
TRANSMIT (Pole coordinate command)	
Sister Tool	
A,B,C SPLINE INTERPOLATION	
RCS HOST (Remote Control)	
Simultaneous Recording (Real time monitoring)	
Analysis of Internal Drive Values	
Network Drive Management	

Figures in inch are converted from metric values.

The SIEMENS controller specifications are subject to change based on the policy of company CNC supplying.

CONTROLLER

HYUNDAI WIA FANUC i Series

Control function / Screen display		Sub / Main spindle function	
Control axis number	Max. 4 Axis X, Z axis X, Z, C axis (M type machine) X, Z, Y, C axis (Y type machine) X, Z, B, C axis (MS type machine)	M-Code function	M4 digit number
Simultaneous control axis number	2axes / Linear and circular (Max. 4axes)	M-Code function lock	
Min. input unit	X, Z, Y, B axis : 0.001mm (0.0001") C axis : 0.001 deg.	Lock sp. speed command	S + 4 digit number, binary number output
Min. increment	X, Z, Y, B axis : 0.001mm (0.0001") C axis : 0.001 deg.	Main sp. constant control	G96, G97
High speed HRV control		Spindle speed override	50% ~ 150% (10% unit)
Inch/metric conversion	G20 / G21	Spindle position decision	
Interlock	Each axis / All axis	Rigid tapping	
Machinelock	Full axis	Tool function / Tool compensation	
Emergency stop		Tool function	T2 + 2
Stroke check 1	Over-travel	Tool offset quantity	64 pairs
Stroke check 2		Tool offset	
Stroke check 3		Tool nose radius compensation	G40, G41, G42
Follow up		Configuration/wear compensation	
Sub off		Direct input of measuring tool compensation B	
Backlash compensation	+/- 0~9999 Pulse (Rapid traverse & cutting feed)	Tool life management	
Position switch		Data input, output and editing function	
Fault load detection	Back spin torque limiter (BST)	Input/output interface	RS232C
High resolution transfer control (HRM)		Memory card input and output	
LCD / MDI	8.4" Color LCD	Program storing capacity	1280m/512kb
Operation		Program registration quantity	Max. 500 programs
Auto handling (memory)		Memory lock	
MDI handling		Background edit	
Search function	Sequence, Program	Additional expandable edit	NC program copy, move, change
Program re-start		Screen, diagnosis and setting function	
Preventive function for mis-handling		Self diagnosis function	
Buffer registration		Historic screen	Alarm and handling screen
Program check function	Dry run, Program check	Help function	
Single block		Outside message	
Feed function		Operation time/counter display	
Manual jog feed	Rapid transfer, Jog, Handle	Actual sp. speed, T code display	
Manual Handle Scale	x1, x10, x100	Actual machining feed rate display	
Feed command	Direct command for F code feed	Handling monitor screen	Rod meter light
Feed override	0~200% (10% units)	Graphic screen	
Jog override	0~2,000 mm/min [79 ipm]	Spindle/servo setting screen	
Rapid transfer override	F1, F5, F25 / F50, F100%	Selection of random 5 EA	
Override release		LCD screen save	Screen saver
Transfer/minute, transfer/rpm		Auto data backup	
Program input and interpolation function		Function according with machine specification	
Nano interpolation	Positioning/Straight/Arc (G00/G01/G02/G03)	Cs contouring control	Turn mill
Dwell function	G04, 0~9999.9999 sec	Stored pitch error compensation	Turn mill
Threading retract		Cylindrical interpolation	Turn mill
Variable lead threading		Canned cycles for drilling	Turn mill
Return of first zero point	G28, manual	spindle orientation expansion	Turn mill, Sub spindle
Decimal number entering		Spindle synchronous control	Sub spindle
Plain selection	G17, G18, G19	Torque control	Sub spindle
Work coordinate selection	G52 to G59	Y axis offset	Y type machine
Manual absolute	"ON" fixed	Angular axis control	Y type machine
Drawing dimension direct input programming	Included chamfering / Corner R		
G code system	A/B/C	Option	
Programmable data input	G10	High speed ethernet	100 Mbps (Option board is required)
Sub program call	10 folds nested	Optional block skip	9 ea
Custom macro B		3rd & 4th reference point return	
Custom macro variable addition	#100 to #199, #500 to #999	Data Server	1GB
Multiple repetitive cycles		Polygon turning	
Multiple repetitive cycles II		Helical interpolation	
Lathe fixed cycle		Dynamic graphic display	
		Protection of data at 8 levels	
		Manual guide i	Conversational Programming (10.4" Color LCD)

Figures in inch are converted from metric values.

The FANUC controller specifications are subject to change based on the policy of company CNC supplying.

CONTROLLER

FANUC 32i-A (L400A/MA | L400C/LC)

Axis control / Display unit	
Controlled axes	Max. 4 axes are available X, Z axes X, Z, C axes (M type machine) X, Z, Y, C axes (Y type machine) X, Z, B, C axes (MS type machine)
Simultaneous controllable axes	2axes / Linear and circular (Max. 4axes)
Least input increment	X, Z, Y, B axes : 0.001 mm (0.0001") C axis : 0.001 deg
Least command increment	X, Z, Y, B axes : 0.001 mm (0.0001") C axis : 0.001 deg
High speed HRV control	
Inch / Metric conversion	G20 / G21
Interlock	Each axis / All axes
Machine lock	All axes
Emergency stop	
Stored stroke check 1	Over-travel
Stored stroke check 2	
Stored stroke check 3	
Follow-up	
Servo-off	
Backlash compensation	+/- 0~9999 pulses (Rapid traverse & cutting feed)
Position switch	
Unexpected disturbance torque detection	Back-spin torque limiter (BST)
High resolution transfer control (HRM)	
LCD / MDI	10.4" Color LCD
Operation	
Automatic operation (memory)	
MDI operation	
Search function	Sequence, program
Program restart	
Wrong operation prevention	
Buffer register	
Program check function	Dry run., program check
Single block	
Feed functions	
Manual jog feed	Rapid, jog, handle
Manual handle feedrate	x1, x10, x100
Feed command	F code feedrate direct command
Feedrate override	0~200 % (10% units)
Jog override	0~2,000 mm/min[79 ipm]
Rapid traverse override	F1, F5, F25/F50, F100%
Override cancel	
Feed per minute / rotation	
Program input & interpolation functions	
Pano interpolation	Positioning / Linear / Circular (G00 / G01 / G02, G03)
Dwell	G04, 0~9999.9999 sec
Thread retract	
Variable lead threading	
1st reference point return	G28, manual
Reference point return check	G27
2nd reference point return	G30
Program stop / End	M00, M01 / M02, M30
Tape code	EIA / ISO
Optional block skip	1 ea
Maximum programmable dimensions	+/- 9999.9999"
Program number	0+4 digits
Absolute and incremental programming	
Decimal point input	
Plane selection	G17, G18, G19
Work coordinate system selection	G52 to G59
Manual absolute	"ON" Fixed
G code system	A
Programmable data input	G10
Sub program call	10 folds nested
Custom macro B	

Program input & interpolation functions	
Addition of custom macro common variable	#100 to #199, #500 to #999
Multiple repetitive cycles	
Multiple repetitive cycles II	
Canned cycles for turning	
Manual guide i	Conversational programming
Sub / Main spindle function	
M-Code function	M4 digits
M-Code function lock	
Lock sp. speed command	S4 digits, binary output
Main sp. constant control	G96, G97
Spindle speed override	50% to 150% (10% units)
Spindle position decision	
Rigid tapping	
Tool function / Tool compensation	
Tool function	T2 + 2
Tool offset pairs	64 pairs
Tool offset	
Tool nose radius compensation	G40, G41, G42
Direct input of measured tool compensation value B	
Tool life management	
Data in/output & editing functions	
Reader / Puncher interface	RS232C
Memory card input/output	
Part program storage length	256 Kbyte
Number of registrable programs expansion	Max. 500 programs
Memory lock	
Background editing	
Extended part program edition	Copy, move, change of NC program
Display, diagnosis & setting functions	
Self-diagnosis function	
History display	Alarm & operation display
Help function	
External message	
Run hour / Parts count display	
Display of actual spindle speed and T code	
Actual cutting feedrate display	
Operating monitor screen	Rod meter light
Graphic display	
Spindle / Servo setting screen	
Selection of 5 optional language	
LCD screen display	Screen saver
Automatic data backup	
Functions according to machine specification	
Cs contouring control	Turn mill
Stored pitch error compensation	Turn mill
Polar coordinate interpolation	Turn mill
Cylindrical interpolation	Turn mill
Canned cycles for drilling	Turn mill
spindle orientation expansion	Turn mill, Sub spindle
Spindle synchronous control	Sub spindle
Torque control	Sub spindle
Y axis offset	Y type machine
Angular axis control	Y type machine
Option	
High speed Ethernet	100 Mbps (Option board is required)
Optional block skip	9 ea
3rd & 4th reference point return	
G code system	B / C
Part program storage length	512 Kbyte
Polygon turning	
Helical interpolation	
Dynamic graphic display	
Protection of data at 8 levels	
Direct drawing dimension programming	Included chamfering / Corner R'

Figures in inch are converted from metric values.

The FANUC controller specifications are subject to change based on the policy of company CNC supplying.

CONTROLLER

FANUC 32i-B (L400MC/LMC)

[] : Option

Controlled axis / Display / Accuracy Compensation	
Control axes	2 axes (X, Z) / 3 axes (X, Z, C) / 4 axes (X, Z, Y, C) 5 axes (X, Z, B, C, A) / 6 axes (X, Z, Y, B, C, A)
Simultaneously controlled axes	2 axes [Max. 4 axes]
Designation of spindle axes	4 axes (1 path), 6 axes (2 path Total)
Least setting Unit	X, Z, Y, B axes : 0.001 mm (0.0001 inch) C, A axes : 0.001 deg
Least input increment	X, Z, Y, B axes : 0.001 mm (0.0001 inch) C, A axes : 0.001 deg
Inch / Metric conversion	G20 / G21
High response vector control	
Interlock	All axes / Each axis
Machine lock	All axes
Backlash compensation	± 0 ~ 9999 pulses (Rapid traverse / Cutting feed)
Position switch	
LCD / MDI	10.4 inch color LCD
Feedback	Absolute motor feedback
Stored stroke check 1	Over travel
Stored stroke check 2, 3	
PMC axis control	
Operation	
Automatic operation (Memory)	
MDI operation	
DNC operation	Needed DNC software / CF card
Program restart	
Wrong operation prevention	
Program check function	Dry run, Program check
Single block	
Search function	Program Number / Sequence Number
Interpolation functions	
Nano interpolation	
Positioning	G00
Linear interpolation	G01
Circular interpolation	G02, G03
Exact stop mode	Single : G09, Continuous : G61
Dwell	G04, 0 ~ 9999.9999 sec
Skip	G31
Reference position return	1st reference : G28 2nd reference : G30 Ref. position check : G27
Thread synchronous cutting	
Thread cutting retract	
Variable lead thread cutting	
Multi / Continuous threading	
Feed function / Acc. & Dec. control	
Manual feed	Rapid traverse Jog : 0~2,000 mm/min (79 ipm) Manual handle : x1, x10, x100 pulses Reference position return
Cutting Feed command	Direct input F code
Feedrate override	0 ~ 200% (10% Unit)
Rapid traverse override	F1%, F25%, 50%, F100%
Override cancel	
Feed per minute	G98
Feed per revolution	G99
Look-ahead block	1 block
Program input	
Tape Code	EIA / ISO
Optional block skip	1 ea
Absolute / Incremental program	G90 / G91
Program stop / end	M00, M01 / M02, M30
Maximum command unit	± 999,999.999 mm (± 99,999.9999 inch)
Plane selection	X-Y : G17 / Z-X : G18 / Y-Z : G19
Workpiece coordinate system	G52, G53, 6 pairs (G54 ~ G59)
Manual absolute	Fixed ON
Programmable data input	G10
Sub program call	10 folds nested
Custom macro	#100 ~ #149, #500 ~ #549
G code system	A
Programmable mirror image	G51.1, G50.1
G code preventing buffering	G4.1
Multiple repetitive cycles I, II	

Program input	
Canned cycle for turning	
Manual Guide i	Conversational auto program
Auxiliary function / Spindle speed function	
Auxiliary function	M & 4 digit
Level-up M Code	High speed / Multi / Bypass M code
Spindle speed function	S & 4 digit, Binary output
Spindle override	0% ~ 150% (10% Unit)
Multi position spindle orientation	M19
Rigid tapping	
Constant surface speed control	G96, G97
Tool function / Tool compensation	
Tool function	T & 2 digit + Offset 2 digit
Tool life management	
Tool offset pairs	32 pairs
Tool nose radius compensation	G40, G41, G42
Geometry / Wear compensation	
Direct input of offset measured B	
Editing function	
Part program storage size	640m (256KB)
No. of registerable programs	500 ea
Program protect	
Background editing	
Extended part program editing	Copy, move and change of NC program
Memory card program edit	
Data input / output & Interface	
I/O interface	RS 232C serial port, CF card, USB memory Embedded Ethernet interface
Screen hard copy	
External message	
External key input	
External workpiece number search	
Automatic data backup	
Setting, display and diagnosis	
Self-diagnosis function	
History display & Operation	Alarm & Operator message & Operation
Run hour / Parts count display	
Maintenance information	
Actual cutting feedrate display	
Display of spindle speed / T code	
Graphic display	
Operating monitor screen	Spindle / Servo load etc.
Power consumption monitoring	Spindle & Servo
Spindle / Servo setting screen	
Multi language display	Support 20 languages
Display language switching	Selection of 5 optional Languages
LCD Screen Saver	Screen saver
Unexpected disturbance torque	BST (Back spin torque limit)
Function for machine type	
Cs contour control (C & A axes)	Mill, MS, Y, SY, LF-Mill, TTMS, TTSY
Polar coordinate interpolation	Mill, MS, Y, SY, LF-Mill, TTMS, TTSY
Cylindrical interpolation	Mill, MS, Y, SY, LF-Mill, TTMS, TTSY
Canned cycle for drilling	Mill, MS, Y, SY, LF-Mill, TTMS, TTSY
Spindle orientation expansion	MS, SY TTS, TTMS, TTSY
Spindle synchronous control	MS, SY TTS, TTMS, TTSY
Torque control	MS, SY TTS, TTMS, TTSY
Y axis offset	Y, SY, TTSY
Arbitrary angular control	Y, SY, TTSY
Composite / Superimposed control	MS, SY TTS, TTMS, TTSY
Balance cutting	MS, SY TTS, TTMS, TTSY
Option	
Additional optional block skip	9 ea
Fast ethernet	Needed option board
Data server	Needed option board
Protection of data at 8 levels	
Tool offset pairs	64 pairs / 99 pairs / 200 pairs
Part program storage size	1280 m (512KB) / 2560m (1MB)
Polygon turning (2 Spindles)	Mill, MS, Y, SY, LF-Mill, TTMS, TTSY
Helical interpolation	
Dynamic graphic display	
Direct drawing dimension program	Including Chamfering / Corner R

Figures in inch are converted from metric values.

The FANUC controller specifications are subject to change based on the policy of company CNC supplying.

GLOBAL NETWORK

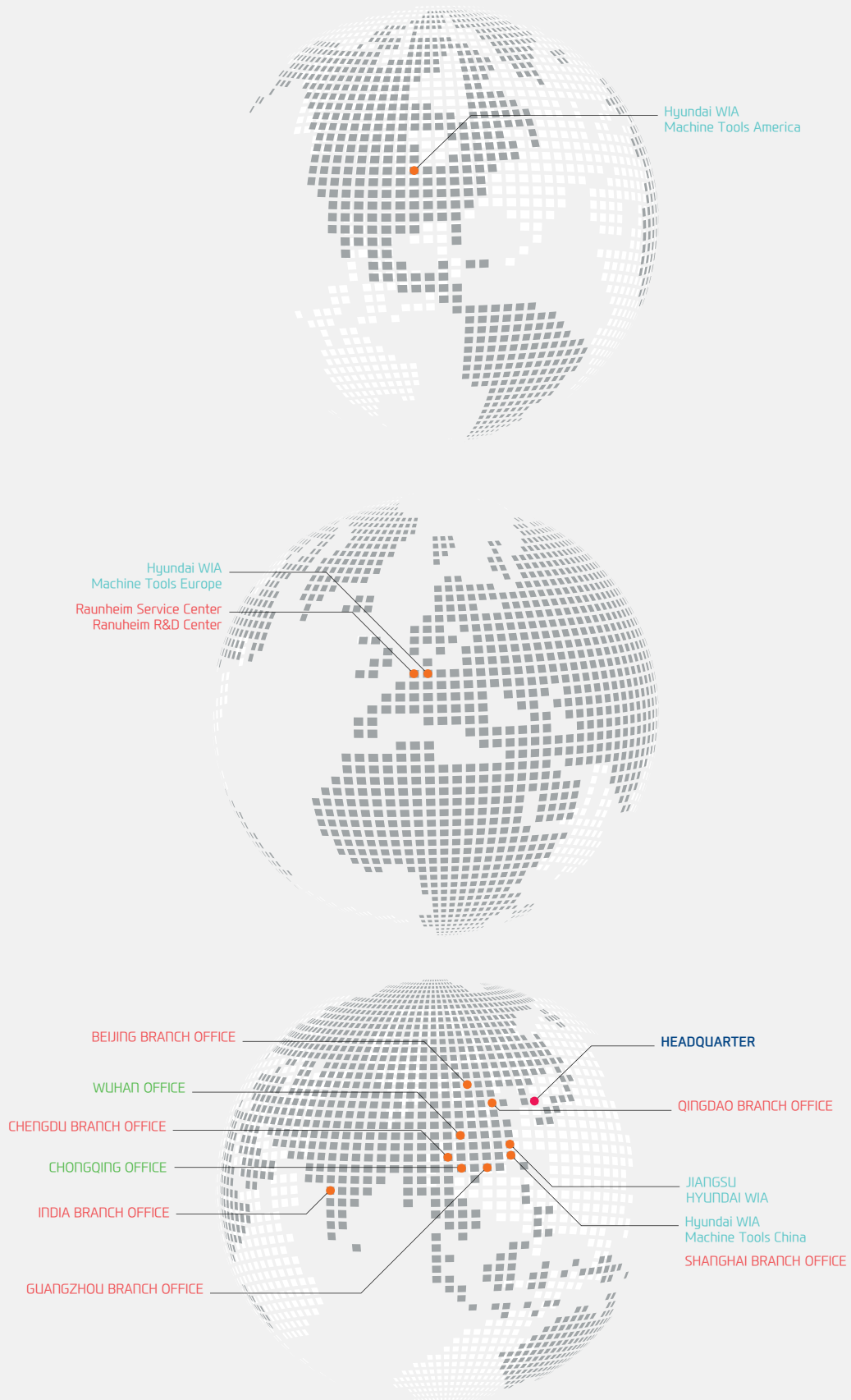

GLOBAL NETWORK



HEADQUARTER

Changwon Technical Center / R&D Center / Factory

153, Jeongdong-ro, Seongsan-gu, Changwon-si,
Gyeongsangnam-do, Korea (Zip Code : 51533)
TEL : +82 55 280 9114 FAX : +82 55 282 9680

Uiwang Technical Center / R&D Center

37, Cheoldobangmulgwan-ro, Uiwang-si, Gyeonggi-do,
Korea (Zip Code : 16082)
TEL : +82 31 596 8209 Fax : +82 55 210 9804

OVERSEAS OFFICES

HYUNDAI WIA Machine Tools America

265, Spring Lake Drive, Itasca, IL, 60143
TEL : +1 630 625 5600
FAX : +1 630 625 4733

Jiangsu HYUNDAI WIA

Company No.6 Fenghuang Road,
Fenghuang Town, Zhangjijagang City,
Jiangsu province, China
TEL : +86 512 5672 6808
FAX : +86 512 5671 6960

Chengdu Branch Office

NO.508 Room, B Block, AFC Plaza, NO.88
Jiaozi Road, High-tech Zone, Chengdu,
China
TEL : +86 028 8665 2985
FAX : +86 028 8665 2985

HYUNDAI WIA Machine Tools Europe

Kaiserleipromenade 5, 63067 Offenbach,
Germany
TEL : +49 69271 472 701
FAX : +49 69271 472 719

Hyundai WIA Machine Tools China Shanghai Branch Office

1-3F, Bldg6, No.1535 Hongmei Road,
Xuhui District, Shanghai, China
TEL : +86 021 6427 9885
FAX : +86 021 6427 9890

Qingdao Branch Office

Room 1207, Cai Fu Building, 182-6 Haier
Middle Road, Qingdao, China
TEL : +86 532 8667 9334
FAX : +86 532 8667 9338

Raunheim Service Center Raunheim R&D Center

Frankfurter. 63, 65479 Raunheim,
Germany
TEL : +49 6142 9256 111
FAX : +49 6142 9256 100

Beijing Branch Office

Floor 14, Zhonghangji Plaza B, No.15
Ronghua South Road, BDA Dist., Daxing
Dist., Beijing, China 100176
TEL : +86 010 8453 9850
FAX : +86 010 8453 9853

Wuhan Office

306-2, A Tower, Jiayu Gpmggian, No12
Chuangye Road, Economic Development
Zone, Wuhan, Hubei, China
TEL : +86 027 5952 3256
FAX : +86 027 5952 3256

India Branch Office

#4/169, Rajiv Gandhi Salai, (OMR),
Kandanchavadi, Chennai-600 096,
Tamilnadu, India
TEL: +91-44-3290-1719

Guangzhou Branch Office

Room 311, Unit 1-3, POLY TAL TU WUP,
Hanxi Avenue, Panyu District, Guangzhou,
China
TEL : +86 020 8550 6595
FAX : +86 020 8550 6597

Chongqing Office

Room 951, #3, Jinrongcheng T3, Jiangbei,
Chongqing, China
TEL : +86 23 6701 2970



<http://machine.hyundai-wia.com>

Head Office & Factory

153, Jeongdong-ro, Seongsan-gu, Changwon-si, Gyeongsangnam-do **Tel** +82 55 280 9500

Overseas Sales Team

16F, 37, Cheoldobangmulgwan-ro, Uiwang-si, Gyeonggi-do **Tel** +82 31 593 8173

HYUNDAI WIA Machine Tools America

265 Spring Lake Drive, Itasca, IL, 60143 **Tel** +1 (630) 625 5600 **Fax** +1 (630) 625 4733

HYUNDAI WIA Machine Tools Europe

Kaiserleipromenade 5, D-63067 Offenbach, Germany **Tel** +49 69271 472 701 **Fax** +49 69271 472 719

India Branch Office

#4/169, Rajiv Gandhi Salai, (OMR), Kandanchavadi, Chennai-600 096, Tamilnadu, India **Tel** +91 44 3290 1719
